

1/4" dia dowel, 8-1/16" long (40 pcs)

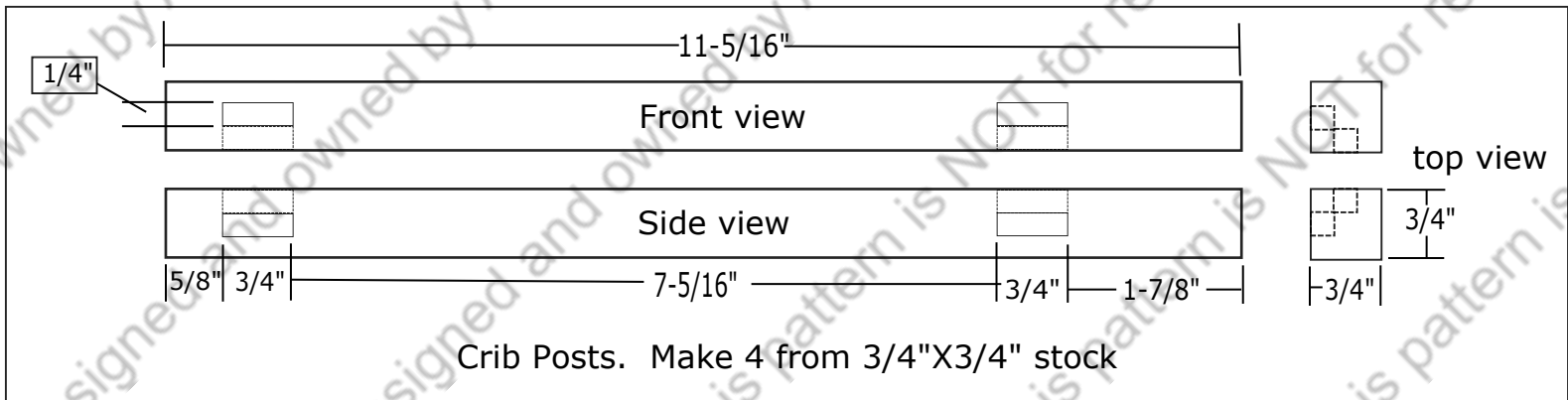

Mattress Support Board Side Rails. Make 2, 14"X1/4"X1/4"

Mattress Support Board end Rails. Make 2, 7-3/4"X1/4"X1/4"