

No Fuss French Press

Automating the French Press Experience



POWERED BY



TECHNOLOGY

THE PROBLEM

French Press: Superior Flavor, Complex Process

Coffee enthusiasts love French press coffee for its superior taste...

...but due to the **complexity, mess, and time required** for brewing and cleanup, it's underused.



THE SOLUTION

Introducing *myiBrew: The 'No Fuss French Press'*

myiBrew, powered by iBrew Technology, **automates** the entire French press process.

It's unique, patent-pending piston mechanism delivers the rich flavor of French press coffee without the mess.



Powered by iBrew Technology



Patent Pending



Interactive App Controls

TECHNOLOGY OVERVIEW

iBrew Technology: A New Way to Brew

DESIGN PATENT SUBMISSION

Our patent-pending iBrew Technology uses a **reverse-piston system** to fully automate the immersion brewing process, separating coffee grounds from liquid with precision and ease.

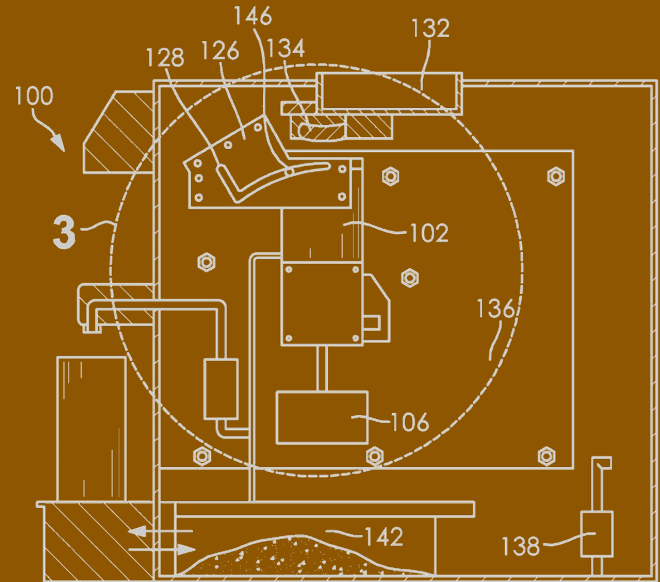

MARKET OPPORTUNITY

Targeting the High-End Coffee Market

\$1.7B

Represents sales of the top 7 machines in the category for 2024*

6-8%

Projected CAGR over the next decade**

\$500

myiBrew's Target price point (for consumer model)

myiBrew, powered by iBrew Technology with a price point between Moccamaster and Ratio Eight is aimed at coffee enthusiasts seeking the highest quality French press experience.

Moccamaster Select



MOCCAMASTER
HANDMADE

My
iBREW

RATIO

Ratio 8



\$360



\$500



\$745

*projection per Report Prime: US High-end Coffee Machine Market Growth 2024-2030 survey

**per Grand View Research: As part of broader 17.66 billion US coffee machine market

COMPETITIVE LANDSCAPE

Standing Out in the Market

While competitors focus on drip or pour-over methods, myiBrew, powered by iBrew Technology, is the **ONLY** machine that automates the French press process, offering the depth of flavor with ease and convenience.



AUTOMATED

DRIP/ POUR-OVER



RATIO



PRODUCT DESIGN

Sleek, Modern, and High-Tech Design

Designed with **minimalist** aesthetics in mind, myiBrew, powered by iBrew Technology is not just a coffee maker, but a **statement piece for the modern kitchen.**

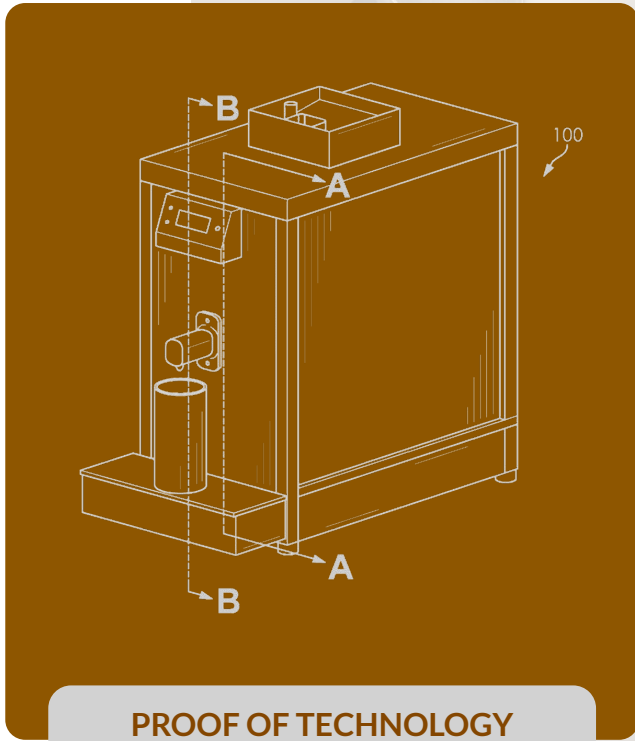

**PROOF OF TECHNOLOGY
WORKING MODEL**



BUSINESS MODEL & GO-TO-MARKET STRATEGY

Scaling Up and Going to Market

Direct-to-consumer
(D2C)

1

Specialty commercial
installations via
selected distribution
partners

2

Licensing to major
manufacturers,
with multiple
offerings, looking
to compete in the
ultra high-end
premium French
press category

3

THREE-TIRED STRATEGY

LEADERSHIP TEAM

The Expert Team Behind The 'No Fuss French Press'



Jared Hollar

Visionary, Financial Advisor, and passionate coffee enthusiast. Jared's strategic insight and passion for coffee fuel the development of myiBrew and iBrew Technology.

[KNOW MORE](#)

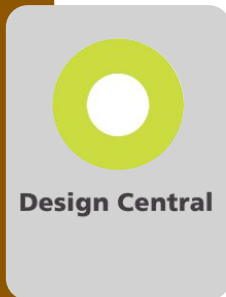

Design Central

A leading product design firm responsible for developing the sleek, high-tech design of myiBrew.

[KNOW MORE](#)



Jeffrey Scheiman

Fractional CMO with over 35 years of experience in marketing and launching successful consumer products, including iCoffee "SteamBrew" and "SpinBrew" consumer coffee brewers. (from Kickstarter to 6,000 stores and the cover of Consumer Reports).

[KNOW MORE](#)

Join Us in Brewing the Future

Be part of the next revolution in homebrewing!

myiBrew, powered by iBrew Technology, will make French press coffee accessible to everyone, with no mess, no hassle, and unmatched flavor.

ibrewtechnology.com