

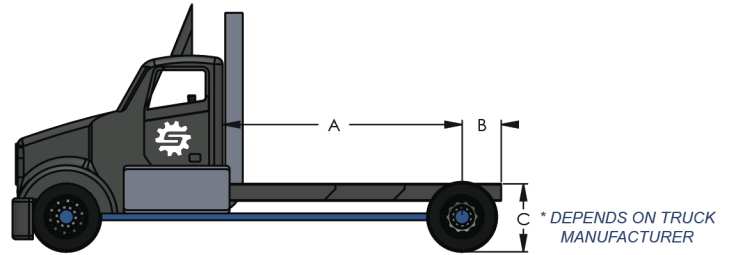

TRUCK SPECIFICATIONS

CAB TO AXLE	A	140 [in]
AXLE TO END	B	23 [in]
FRAME TO GROUND	C	*
VEHICLE CAPACITY		32,000 [lbs]



TRANSPORT

FRAME TO TOP OF BED	D	22 [in]
MAX FORK	E	111 [in]*
FULL LOAD	F	169 [in]
LOADED LIGHT	G	92 [in]
FRAME END TO MAST	H	24 [in]
FRAME END TO SQUEEZE	I	40 [in]

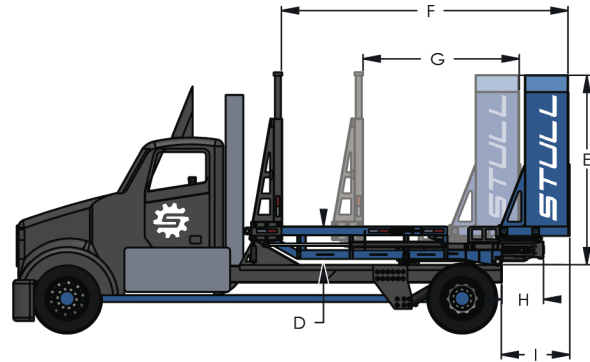

SELF-LOAD

MAX SWING	J	174 [in]*
MAX BED	K	151 [in]*
MAX OPENING HEIGHT	L	170 [in]
MAST CAPACITY		12,500 [lbs]
MACHINE WEIGHT		8,000 [lbs]
MACHINE CAPACITY		10,000 [lbs]

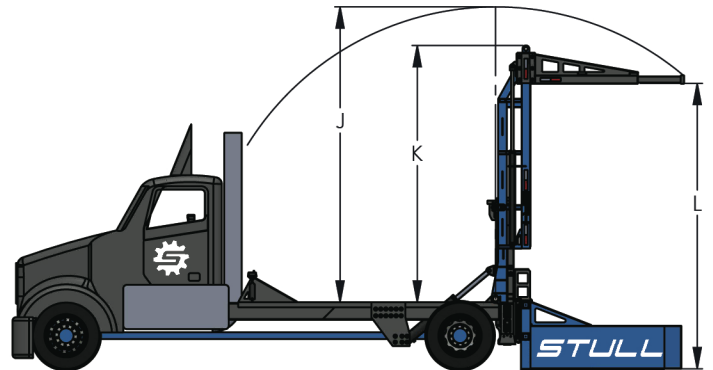

SPLIT & STOW

TELESCOPE MAX	M	90 [in]*
TELESCOPE MIN	N	66 [in]*
POSITIVE TILT ANGLE	O	15 [deg]
MAX LIFT HEIGHT	P	133 [in]*

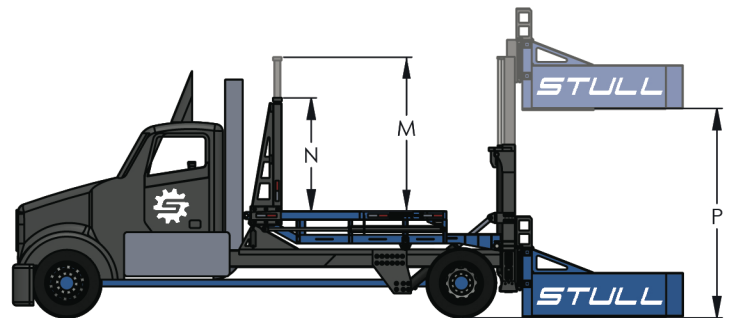

SQUEEZE

MAX OPENING	Q	105 [in]
MIN OPENING	R	69 [in]

