

RDI Systems

2915 Tennessee Avenue North, Parsons, TN 38363
(731) 847-6361 *(800) 826-7036*

REFRIGERATING UNIT - COOLER

MODEL	DC098T3	HP	1.0
VOLTS	208-230	PH	1
REFRIGERANT	R448A	CYCLES	60
TOTAL LOAD	8.1	BTUH	7,940
MIN. CIRCUIT AMPACITY	9.7	TOTAL HEAT REJECTED	11,320
MAX. EXTERNAL FUSE SIZE	15	EVAP. FAN	0.6
COMP. RLA	6.3	EVAP. FAN	38W
COMP. LRA	48.0	DEFROST	AMPS
LOW SIDE DESIGN PRESS.	230	COND. FAN	0.6
HIGH SIDE DESIGN PRESS.	475	COND. FAN	38W
AWEF	5.61	WEIGHT	280
		LBS.	

NOTE:
SYSTEM IS SUPPLIED WITH A HOT GAS CONDENSATE PAN. A CONDENSATE DRAIN LINE IS NOT REQUIRED.

NOTE:
18" CLEARANCE REQUIRED ON ALL SIDES FOR PROPER OPERATION OF POLAR PAK SYSTEMS.

ITEMS PROVIDED INCLUDE:

1. Liquid Line Filter/Driers
2. Electronic Temp Control (Installed)
3. Expansion Valve (Installed)
4. Scroll Compressor-Copeland
5. High Pressure Switch
6. Fan Motors-208-230/1/60



THIS DRAWING/PRINT IS THE PROPERTY OF RDI SYSTEMS. IT IS TO BE USED ONLY FOR THE PROJECT AND INSTALLATION SPECIFICALLY IDENTIFIED HEREIN. ANY REVISIONS MUST BE APPROVED BY THE ENGINEERING AND DESIGN DEPARTMENT.

SIGNED APPROVED PRINT MUST BE RECD. B./A. FAB.
 APPROVED AS DRAWN
 APPROVED AS NOTED
 REVISE AND RESUBMIT

SIGNED _____ DATE _____

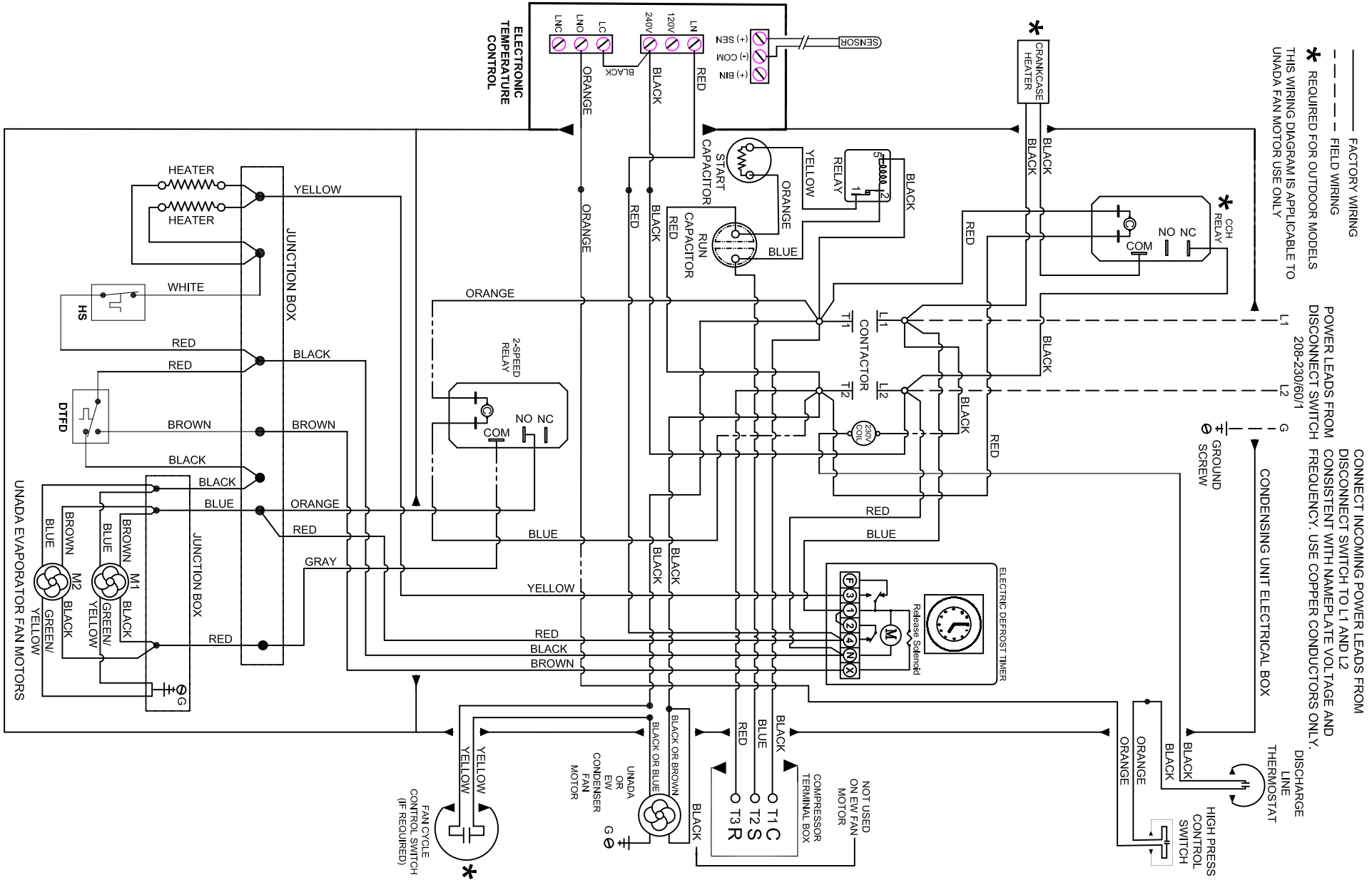

R448A POLAR PAK FREEZER WIRING DIAGRAM 208-230/1/60

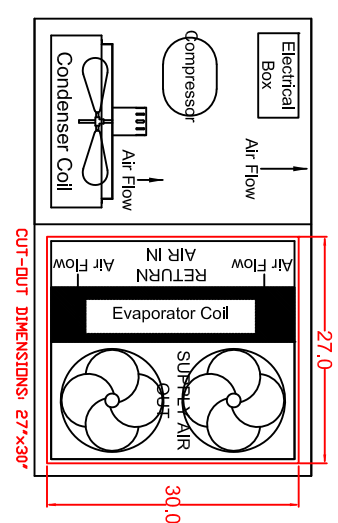
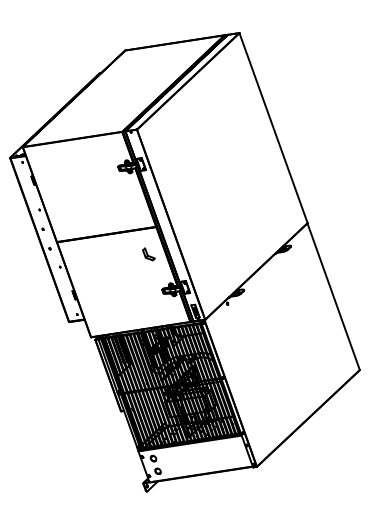
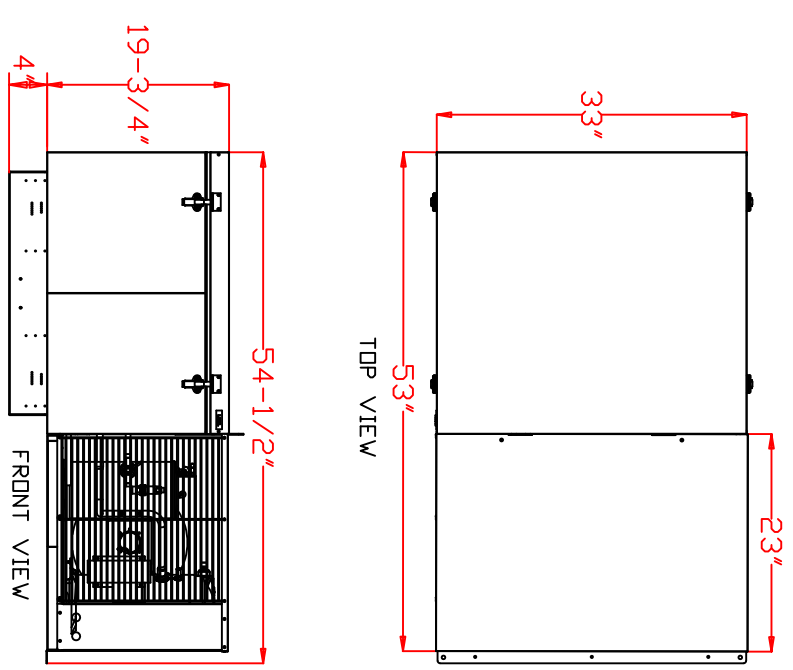

CUT-OUT DIMENSIONS: 27"x30"

DATE	NO.	DESCRIPTION OF CHANGE	AUTH	BY
10.23.20	4	REVISED MODEL DESIGNATION		DW

SCALE	NONE	DEFILER	DRAWN BY: DW
DATE	11.22.2019	REVISION	RCR/PAK QUOTE NO.

RDI Systems
DRAWING NUMBER: DC098T3