

# RDI Systems

2915 Tennessee Avenue North, Parsons, TN 38363  
(731) 847-6361 \*(800) 826-7036\*

REFRIGERATING UNIT - FREEZER

MODEL	DF098T3	HP	1.0
VOLTS	208-230	PH	1
REFRIGERANT	R448A	CYCLES	60
TOTAL LOAD	10.5	BTUH	4,060
MIN.CIRCUIT AMPACITY	12.7	BTUH	8,910
MAX.EXTERNAL FUSE SIZE	20	EVAP. FAN	0.6
COMP. RLA	8.7	AMPS EA.	
COMP. LRA	55.0	EVAP. FAN	38W
LOW SIDE DESIGN PRESS.	230	HP	
HIGH SIDE DESIGN PRESS.	475	COND. FAN	0.6
AWEF	3.06	AMPS	
		DEFROST	4.3
		COND. FAN	0.6
		COND. FAN	38W
		HP	
		WEIGHT	280
		LBS.	

**NOTE:**  
SYSTEM IS SUPPLIED WITH A HOT GAS CONDENSATE PAN. A CONDENSATE DRAIN LINE IS NOT REQUIRED.

**NOTE:**  
18" CLEARANCE REQUIRED ON ALL SIDES FOR PROPER OPERATION OF POLAR PAK SYSTEMS.

ITEMS PROVIDED INCLUDE:

1. Liquid Line Filter/Driers
2. Electronic Temp Control (Installed)
3. Expansion Valve (Installed)
4. Scroll Compressor-Copeland
5. High Pressure Switch
6. Fan Motors-208-230/1/60



THIS DRAWING/PRINT IS THE PROPERTY OF RDI SYSTEMS. IT IS TO BE USED ONLY FOR THE PROJECT AND INSTALLATION SPECIFICALLY IDENTIFIED HEREIN. ANY REVISIONS MUST BE APPROVED BY THE ENGINEERING AND DESIGN DEPARTMENT.

SIGNED APPROVED PRINT MUST BE RECD. BY FAB.  
 APPROVED AS DRAWN  
 APPROVED AS NOTED  
 REVISE AND RESUBMIT

SIGNED \_\_\_\_\_ DATE \_\_\_\_\_

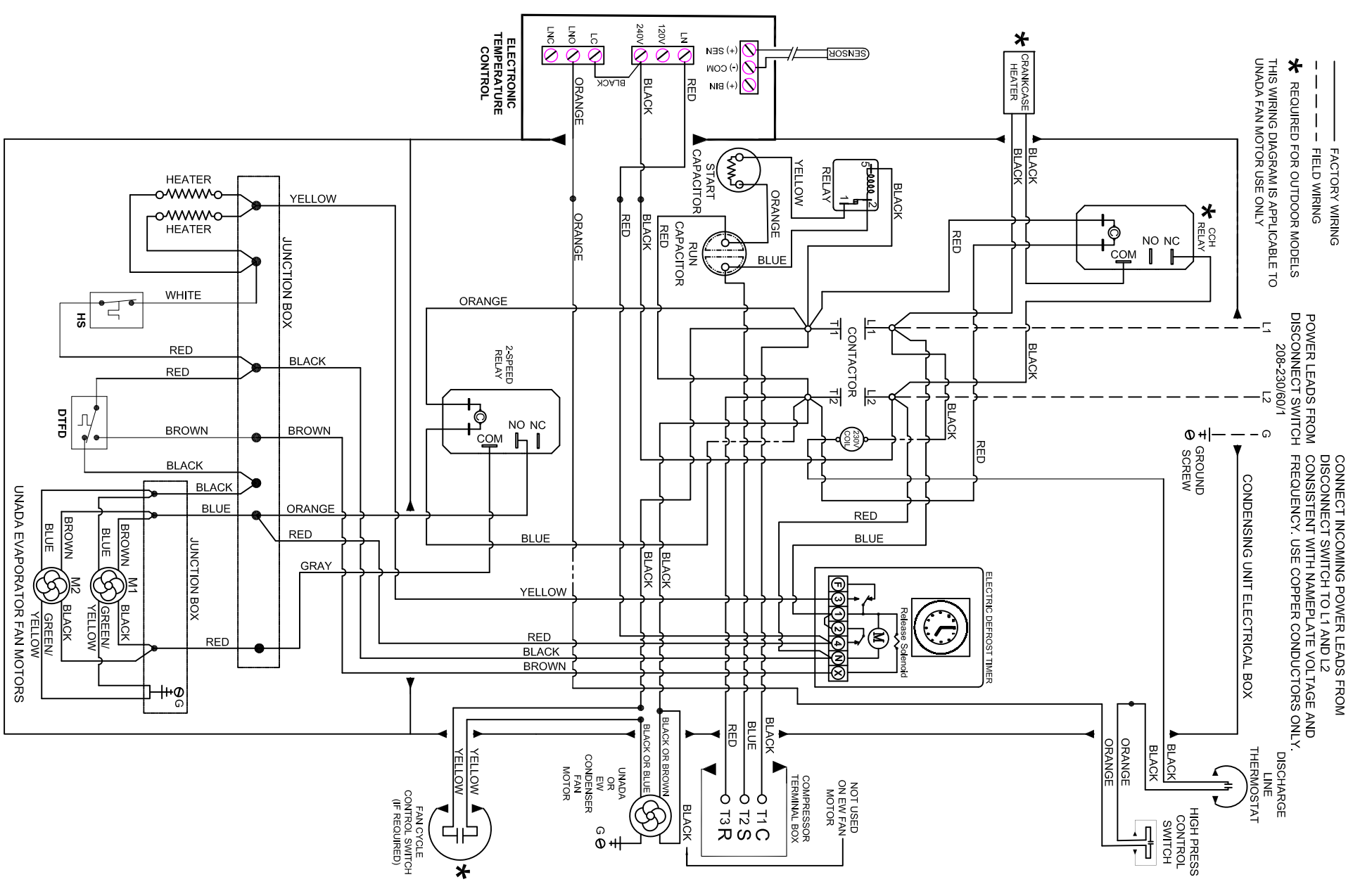

R448A POLAR PAK FREEZER WIRING DIAGRAM 208-230/1/60

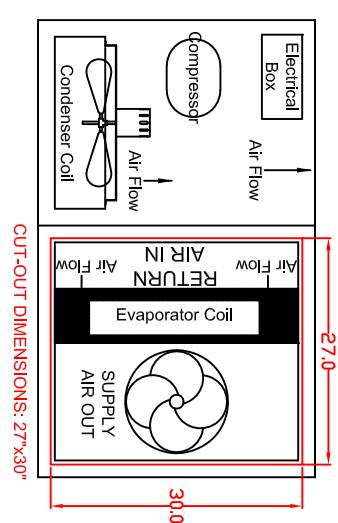
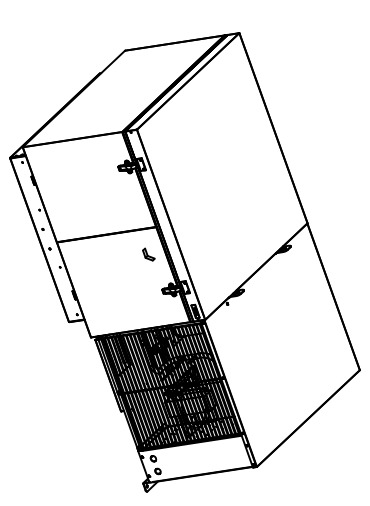
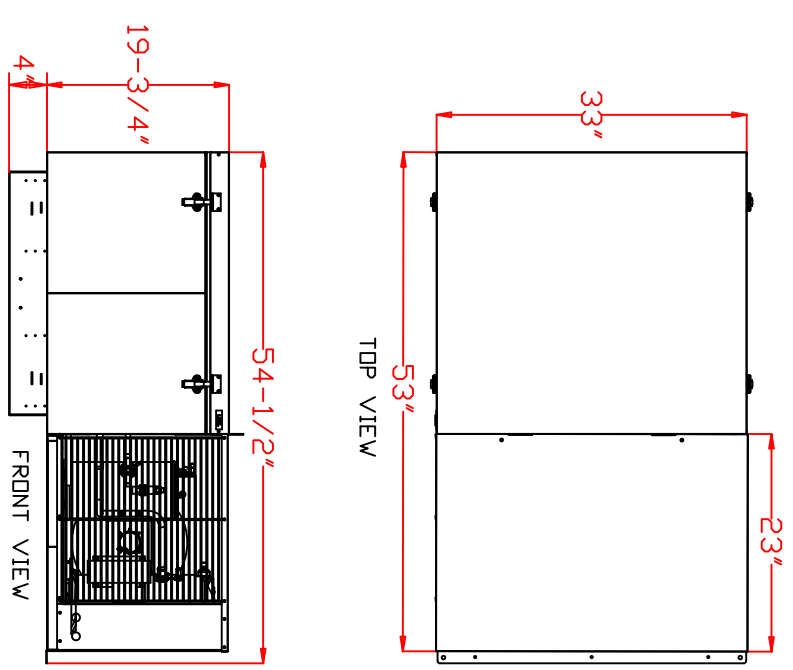

DATE	NO.	DESCRIPTION OF CHANGE	AUTH	BY
10.23.20	4	REVISED MODEL DESIGNATION		DW
DF098T3 (208-230/1/60)				
SCALE	NONE	DEALER	DRAWN BY: DW	
DATE	11.22.2019	REVISION	RCD/PAK QUOTE NO.	
DRAWING NUMBER: DF098T3				