

# User Guide

Systems for the UFO Data Acquisition Project (UFODAP)



[ufodap.com](http://ufodap.com)

Revised 10 June, 2026, Version 1.33

Copyright © 2026 Ronald Olch

RHOlch Systems

## Disclaimer

This document is under active development and as such there may be mistakes and omissions — please watch out for these and report any you find to the developer at [team.ufodap@gmail.com](mailto:team.ufodap@gmail.com).

Contributions of material, suggestions and corrections are welcome.

Copyright © 2026 Ronald Olch

All rights reserved

THIS SOFTWARE IS PROVIDED BY THE COPYRIGHT HOLDER ON AN "AS IS" BASIS AND ANY EXPRESS OR IMPLIED WARRANTIES, INCLUDING, BUT NOT LIMITED TO, THE IMPLIED WARRANTIES OF MERCHANTABILITY AND FITNESS FOR A PARTICULAR PURPOSE ARE DISCLAIMED. IN NO EVENT SHALL THE COPYRIGHT OWNER BE LIABLE FOR ANY DIRECT, INDIRECT, INCIDENTAL, SPECIAL, EXEMPLARY, OR CONSEQUENTIAL DAMAGES (INCLUDING, BUT NOT LIMITED TO, PROCUREMENT OF SUBSTITUTE GOODS OR SERVICES; LOSS OF USE, DATA, OR PROFITS; OR BUSINESS INTERRUPTION) HOWEVER CAUSED AND ON ANY THEORY OF LIABILITY, WHETHER IN CONTRACT, STRICT LIABILITY, OR TORT (INCLUDING NEGLIGENCE OR OTHERWISE) ARISING IN ANY WAY OUT OF THE USE OF THIS SOFTWARE, EVEN IF ADVISED OF THE POSSIBILITY OF SUCH DAMAGE.

## Contents

INTRODUCTION.....	9
ABOUT THE DEVELOPER.....	10
SYSTEM REQUIREMENTS.....	11
PURPOSE.....	14
FUNCTIONAL DESCRIPTION.....	19
HARDWARE CONFIGURATION OPTIONS.....	21
MISSION CONTROL (MC).....	24
Introduction.....	24
MC Quick Start Guide.....	25
Mission Control menus and displays.....	30
System Status controls.....	33
Weather data collection.....	34
Aircraft flight data collection.....	35
Operating controls.....	37
Map Controls.....	38
Mission Setup.....	39
Mission Configuration.....	40
Sensor OTDAU Configuration.....	43
Sensors MSDAU Configuration.....	45
Sharing Options.....	53
Setup Selections.....	55
Help.....	57

OPTICAL TRACKING DATA ACQUISITION UNIT (OTDAU) .....	59
Introduction .....	59
OTDAU Quick Start Guide .....	60
System Configuration and Operation .....	67
System Configuration.....	69
Gamepad controls .....	79
Path Capture, Display and Recording.....	81
Automatic camera homing functions.....	84
Positioning a PTZ camera .....	85
Setting a bounding area.....	86
Enabling Pan, Tilt and Zoom .....	89
Manual Recording.....	90
Camera Configuration.....	91
A comparison of xvid, mp4 and avi.....	99
ONVIF Camera Configuration Assistant .....	101
USB Camera Assisted Configuration.....	104
DSLR Information .....	106
Camera configuration Setup Options .....	110
IP Camera setup.....	114
IP camera setup problems.....	115
Setup for All-Sky (panoramic) Camera .....	119
Setup for dual cameras.....	121
Setting focus for night sky tracking .....	123
Data interpretation and adjustments .....	124
Testing otdau setup and tracking.....	126

Camera Sharing.....	128
Pan/tilt Positioner Configuration Options .....	132
Tracking Options.....	135
Touring Configuration .....	139
Recording options .....	142
Primary Video and Data Options .....	142
DSLR Control Options .....	144
Auxiliary Video Options.....	146
Audio Recording Options.....	147
Data path .....	148
Log File.....	150
Data Analytics Options.....	151
Object Identification .....	151
Spectral Analysis .....	162
File Sharing options .....	164
Send Email .....	164
Upload Data.....	166
Setup Options .....	176
Display options .....	177
PTZ Control and tracking options .....	180
AutoStart Setup .....	187
Help .....	188
About .....	188
Manage license.....	189
OTDAU GPS / ADS-B AIRCRAFT TRACKING SYSTEM .....	191

Introduction .....	191
GPS SUBSYSTEM .....	193
What is GPS? .....	193
GPS Hardware Requirements .....	194
GPS Installation and Setup.....	196
GPS Troubleshooting .....	197
Understanding GPS Data .....	201
GPS Fallback Mode .....	201
ADS-B SUBSYSTEM.....	202
What is ADS-B?.....	202
ADS-B Hardware Requirements .....	204
ADS-B Installation and Setup .....	209
GPS/ADS-B Display Interface.....	214
Display Overview .....	214
Display Components.....	214
Aircraft Filtering and Display Criteria .....	220
Aircraft Overlay on Wide Video Display .....	222
Overview.....	222
Enabling the Aircraft Overlay .....	224
Camera Azimuth/Elevation Calibration .....	225
ADS-B Data Logging.....	226
Log File Location .....	226
Log File Format.....	227
Log File Growth .....	228
GPS TROUBLESHOOTING .....	229

Recorded Folder and file Structure .....	233
Program and Configuration File Structure.....	237
PAN/TILT DATA ACQUISITION UNIT (PTDAU).....	240
PTU Payloads.....	243
AC Version Function Description .....	244
PT Unit Connectors .....	245
PoE PTDAU Functional Description .....	246
PTUSB Functional Description .....	248
PTDAU Operation .....	250
PTDAU Software boot process .....	252
MULTISENSOR DATA ACQUISITION UNIT (MSDAU).....	253
Introduction .....	253
Description and Specifications .....	256
Display and Indicators.....	259
Joystick settings.....	260
Software boot process .....	261
APPENDIX A: ADS-B AIRCRAFT TRACKING SUPPLEMENT .....	262
Understanding ADS-B Reception.....	262
Dual Data Sources.....	262
Performance Expectations .....	263
Typical RF Reception Performance .....	263
Message Accumulation Patterns .....	263
Tracker Table Reference .....	264
Column Descriptions.....	264
Row Color Coding.....	265

Wide Video Overlays .....	267
Enabling Overlays.....	267
Overlay Elements .....	267
Field of View Calculation .....	267
Troubleshooting Reception Issues.....	268
No Aircraft Displayed .....	268
Low Message Rate .....	268
Signal Strength Interpretation .....	270
Understanding Signal Bars .....	270
Factors Affecting Signal Strength .....	270
Performance Optimization.....	271
Recommended Gain Settings.....	271
Display Performance .....	271
Quick Reference .....	272
Performance Targets .....	272
Normal Behavior .....	272
Glossary .....	272
ADS-B Quick Reference Summary .....	274
APPENDIX B: MISSION CONTROL SW CHANGE LOG.....	279
APPENDIX C: OTDAU SOFTWARE CHANGE LOG .....	282
APPENDIX D: MSDAU COMPONENT DATA SHEETS.....	299

## Introduction

This User Manual contains all essential information for the user to make full use of the Unidentified Flying Object Data Acquisition System (UFODAS). This manual includes a description of the system functions and capabilities, contingencies and alternate modes of operation, and step-by-step procedures for system access and use.

Refer to the Quick Start sections for an initial installation and introduction to the “look and feel” of the UFODAS system.

Questions and suggestions for improvements may be made by email to:

[rho1ch@gmail.com](mailto:rho1ch@gmail.com)

UFODAS systems are the basis for the data collection methodology of the UFO Data Acquisition Project (UFODAP). The UFODAP project is a result of collaboration between the UFO Camera Project and the work of engineer/computer scientist Ron Olch. Mr. Olch had independently developed the concepts of a low-cost optical tracking system beginning in 2014 as his personal research project as a member of the Los Angeles UFO Research Group. In 2016, Wayne Hollenbeck joined the LA group and expressed interest in the work he had accomplished, which was directly in line with the goals of the UFO Camera Project. Subsequently, MUFON OC, which had been funding the project for software development, shifted some of those funds as a research and development grant to Mr. Olch, who has continued the development work that has resulted in the UFO Data Acquisition System (UFODAS).

The technical focus of the UFODAP has been on resolving a portion of this issue by providing methods to recognize, track and photograph anomalous objects while simultaneously collecting data from multiple sensors. While this sort of capability has been investigated and other systems have been built, their design emphasis has not been on such low cost to make practical the kind of significant numbers to be deployed to have a practical impact on Ufology. By “low-cost” we assume a unit cost of perhaps \$2500 or less. Thus, over the last 12 years significant progress has been made on an Unidentified Flying Object Data Acquisition System (UFODAS) that attempts to address this issue such that hardware and software is available today for practical data collection.

Please see the following web site for more information:

[www.ufodap.com](http://www.ufodap.com)

Please contact us at:

[team.ufodap@gmail.com](mailto:team.ufodap@gmail.com)

## About the Developer

UFODAS development was initiated in 2014 by **Ronald Olch** – MS Engineering and Computer Science, UCLA. His resume outlining his extensive background in electronics, software and system design may be found on LinkedIn:

<https://www.linkedin.com/in/ronald-olch-05b8a11>

Mr. Olch was a founding member of the Los Angeles UFO Research Group (LAUFORG), which began at UCLA in about 1973 and has met every month since then. His research interest behind developing UFODAS is collecting scientific data to better understand UFO/UAP/AAP phenomena.

## System Requirements

Minimum hardware and software required for implementation of an UFODAS system include:

- Windows 10 or 11 OS on a PC Computer with Core i5 processor, 16GB memory and 2GB free disk memory. A faster computer, e.g., an i7 or i9 or with higher speed ratings may provide higher analysis frame rates and thus better tracking of faster targets. **NOTE:** A computer with a high-end graphics processor, such as the Dell Alienware series, is not required but may improve performance with high-resolution, higher frame rate video streaming. Future versions of the OTDAU software will be enhanced to use any GPU available including those available on earlier PCs.
- The PC needs to have installed the current version of Visual C++ Redistributable installs for Microsoft C and C++ (MSVC) runtime libraries. See <https://learn.microsoft.com/en-us/cpp/windows/latest-supported-vc-redist?view=msvc-170> to download and install the latest version for your computer.
- Alternatively, a MAC OS with a Windows Virtual Machine as described below may be used. Note that this option will provide somewhat slower operation than running on a native PC with a similar processor:

<https://www.howtogeek.com/187359/5-ways-to-run-windows-software-on-a-mac/>

- For OTDAU, at least one camera interfaced to the PC. The camera may be an internal webcam, external USB camera or any UFODAP supported external IP camera.
- If when starting up OTDAU you get an error concerning getMachineID, having more than one wireless network adapter enabled may cause the problem.
- If when starting up OTDAU you get a WMI-related error you will need to restore your WMI repository by entering (or copy/paste) the following commands at an elevated (Admin) command prompt and then restarting the WMI service using wmicmgmt.msc, started from the Windows search box:

```
mofcomp %windir%\System32\wbem\cimwin32.mof
mofcomp %windir%\System32\wbem\wmiutils.mof
regsvr32 %windir%\System32\wbem\wbemcore.dll
```

Currently supported IP camera manufacturers and model numbers include:

Amcrest	IP2M-841, IP8M-2899 (May not be in full ONVIF compliance)
Axis*	M3025-VE
Dahua	DH-SD59A230TN-HNI, 50230UNI-A, 50A230, 50232XANR, 50432XANR, NK8BR4, N51BD22, N53AB52, N53CB62, N65CL5Z, N85EFN2, 49225TNI, 49425TNI, DH-IPC-EBW81242N, DH-SD6AL445XA-HNR-IR
Hanwa	8300
Hino	IPC7F12-AF, IPC7F12E-AF
Hikvision	DS-2DE4A425IW-DE
Luminys	N5B-4CA2, N5B-8CA2, P54-4SA25, P45-8RA25, N9F-8RA1, N9F-12RA1, P54-4DB25, P55-4SA45, P44-8DB25
Reolink	RLC823A (May not be in full ONVIF compliance)
Samsung	SNP-3750
Sony	SNC-RX570N, RZ25N
Trendnet	TV-IP450P (V1.1R)
Uniview	IPC868ER-VF18-B, IPC6424SR-X25-VF, IPC6658SR-X25-VF, TIC2A32SA series

Other cameras by the same manufacturers may also be used. Please contact the UFODAS developer to check compatibility or attempt to use any camera not listed. The OTDAU software also provides a Camera Configuration Assistant (CCA) feature to semi-automatically discover correct settings for other ONVIF-compliant cameras. To use the CCA, your camera must be configurable to provide an On-Screen Display (OSD) of pan, tilt and zoom values and be able to display a channel ID (a user-entered character string).

Any camera that is certified ONVIF-compatible should work with the UFODAS software. ONVIF (Open Network Video Interface Forum) is an international organization established to promote standardized interfaces for effective interoperability of IP-based physical security products. Camera manufacturers who want to establish the ONVIF compliance of a particular product tests the product using an ONVIF test suite and file a report with ONVIF which then lists the product on its website. Some cameras claim to be ONVIF compliant but may not be if not listed on the ONVIF site:

<https://www.onvif.org/conformant-products/>

Cameras that are not ONVIF-compliant typically use a manufacturer-specific communication protocol, such as CGI (Common Gateway Interface) to communicate with hosts such as a UFODAS computer. Custom code must be added to UFODAS to support

such a camera if not already in place. Currently supported cameras above that operate this method are the Sony and Samsung cameras. To enable the development of this custom code, any new camera proposed for UFODAS use must have available a comprehensive CGI document describing all its commands. Some CGI command sets do not implement the minimum set of commands necessary for OTDAU control. Such compatibility will be determined during the custom development process.

Note that even cameras that claim to meet the ONVIF specification often do not or do so only partially. Even those that are compliant must be evaluated for correct operation by UFODAS OTDAU software. All the cameras listed above have been fully qualified and OTDAU software has been designed to work correctly with them.

**\*Note:** Use of Axis cameras will not connect for ONVIF access unless the “Enable replay attack protection” box is unchecked in WebService under System Options > Advanced > Scripting (for the M3025). See:

[https://support.avigilon.com/s/article/Axis-Camera-Connection-Gets-an-Error-ONVIF-Sender-not-authorized-error-or-Invalid-username-or-password?language=en\\_US](https://support.avigilon.com/s/article/Axis-Camera-Connection-Gets-an-Error-ONVIF-Sender-not-authorized-error-or-Invalid-username-or-password?language=en_US)

## Purpose

It is apparent that timely collection of high-quality optical and electromagnetic scientific data related to UFO events has been difficult to obtain. Individuals who are in the position to potentially record such events often do not have the appropriate equipment at hand. Even MUFON Field Investigators may not have the means to wait for hours, days or longer to capture an event and, at that time, record all necessary data in a verifiable way.

Even when photos or videos are recorded, they often lack verifiable associated meta-data such as the exact location of the camera and sensors, the azimuth and elevation of the where the camera is pointing, time of day, associated electromagnetic and gravitational perturbations at that time and so on. Also, even if a single camera captured such data, the track of an object, its location on or above the Earth and its altitude, could not be ascertained without combining the data of at least two such systems, placed some distance from each other.

The focus of the UFODAS development has been on resolving a portion of this issue by providing methods to recognize, track and photograph anomalous objects while simultaneously collecting data from multiple sensors. While this sort of capability has been investigated and other systems have been built, their design emphasis has not been on such low cost to make practical the kind of significant numbers to be deployed to have a practical impact on Ufology. By “low-cost” we assume a unit cost of perhaps \$2000 or less. Thus, over the last five years significant progress has been made on an Unidentified Flying Object Data Acquisition System (UFODAS) that attempts to address this issue.

UFODAS consists of a Windows operating system-based personal computer and options of one or two cameras and other clusters of sensors. In addition, there is software to pull data and video, locally or over the internet, from multiple sensor locations and triangulate target objects. The system supports a wide range of supported cameras including USB webcams up to sophisticated all-weather IP cameras with pan and tilt as well as optical zoom. The software architecture is designed to adapt to most any camera or Pan-Tilt-Zoom (PTZ) mechanism in the future by addition of a single software element, without modification to the main UFODAS software. In dual camera applications, one camera may be a non-PTZ type that views a wide field of interest including all-sky cameras. The second camera can be a PTZ camera automatically directed to point at the object based upon its relative location in the field of view of the wide-angle camera. The PTZ camera then independently tracks the object. Whether using one camera or two, the processor samples frames from the wide-field camera and through some sophisticated image analysis, detects qualified moving objects. It then directs the pan-tilt head to point the telephoto camera at the object and collects images from it. The software can acquire an object of interest and smoothly track and zoom into a moving object even with a single camera. Maintaining track while moving the camera, which causes the background to also move, was a significant part of the development effort.

The software architecture employed enables support for additional cameras, whether simple or sophisticated, including those with fast PTZ operation, higher resolution or non-visible spectrum devices.

Triangulation of a sighted target object requires accurate azimuth and elevation of the tracking camera. The optional MultiSensor Unit (MSDAU) is an embedded hardware and software subsystem that provides camera GPS coordinates and precise time as well as 3DOF magnetometer and DC accelerometer for gravitational measurements. The same sensors may be used to sense perturbations in those fields and include that data with a camera-based event or provide the initial trigger for subsequent data collection.

The software also provides several related functions which include:

- When a qualified event is detected, send an email to a designated address with data that includes attached photos, GPS coordinates of the camera and object azimuth and elevation.
- Saves automatically named photos and videos to folders it creates in local memory.
- A sophisticated Graphical User Interface (GUI) for user-friendly operation.
- Real-time track correlation with data from OpenSky to distinguish unknowns from aircraft.
- Real-time weather conditions local to deployed DAUs.
- Additional methods to eliminate false alarms such as birds and aircraft including the use of deep learning methods.
- Support for pan-tilt-zoom heads that provide mounts for various cameras or other sensors.
- Support for DSLR camera shutter control.

Ongoing development work includes:

- MSDAU interface for acoustic sensors.
- MSDAU interface for radar data.
- Use of an optical gradient filter to determine target spectrum
- Differential magnetometry to determine target magnetic field strength and direction
- Support for other types of cameras such as those operating in the Long Wave Infrared (LWIR) portion of the spectrum.

The UFODAS system architecture provides for an extremely broad set of configuration options to meet the goal of providing systems for every budget and type of case. UFODAS architectural components consist of:

- **Mission Control (MC)** GUI-controlled software. MC interfaces with other elements via the Internet to bring together, in one location, data from up to six Data Acquisition Units (DAUs). DAUs may be any combination of OTDAUs, MSDAUs or PTDAUs.
- **Optical Tracking Data Acquisition Unit (OTDAU)**. An OTDAU includes a GUI-controlled software element that provides an interface to many types of cameras for optical target acquisition, tracking and video storage. An OTDAU can either stand alone or work with MC. Two OTDAUs and an MC form a comprehensive solution to tracking with triangulation and both OTDAU and MC local data storage.
- **MultiSensor Data Acquisition Unit (MSDAU)**. An MSDAU consists of an all-environment enclosure with an embedded Raspberry Pi computer interfaced to nine different sensors including GPS, magnetometer, DC accelerometer, AC accelerometer, temperature and pressure. An MSDAU communicates with an MC over the Internet to provide all of this data in real-time. An MSDAU may also transmit data from other USB-interfaced sensors such as a Trifield meter.
- **Pan/Tilt Data Acquisition Unit (PTDAU)**. A high-speed pan/tilt unit that can carry up to 10Kg of an instrumentation payload. PTDAU position control and position feedback may be via USB or by PoE++. When used with PoE++, a single cable carries power and Ethernet signals for all operations. Currently, the PTDAU may be configured with up to two IP cameras and a DSLR camera for simultaneous still-frame capture at up to 48Mp and special lenses and filters.
- All cameras and the MSDAU may be either tripod or wall/poll mounted. The PTDAU is tripod mounted. Each unit is powered by and communicates data via a single Ethernet. An MC may be configured to use co-located MSDAU data to locate the camera and collect multi-sensor data simultaneous with tracking events.

All collected data is initially stored on the computer running OTDAU or MC software. The MSDAU does not store any data. All MSDAU data is stored on the computer running the MC software that is communicating with the MSDAU. All data is available to

the user to store or send by any common method such as uploads to cloud data storage, email attachment or remote access via remote PC control software.

OTDAU also includes the means for a user to send curated data to the UFODATA organization ([ufodata.net](http://ufodata.net)) for addition to scientific research.

UFODAS cameras, the MSDAU, OTDAU and MC software as well as numerous installation and support options are available via the UFODAP website. Several cameras are offered, each with unique capabilities and price levels ranging from a fixed lens, wide-angle unit, an All-Sky 360-degree camera to 12x and 32x PTZ models. OTDAU software allows the use of each type alone or in combination.

The figure below illustrates a high-level view of the UFODAS architecture. A DAU is either an OTDAU with one or two cameras or an MSDAU.

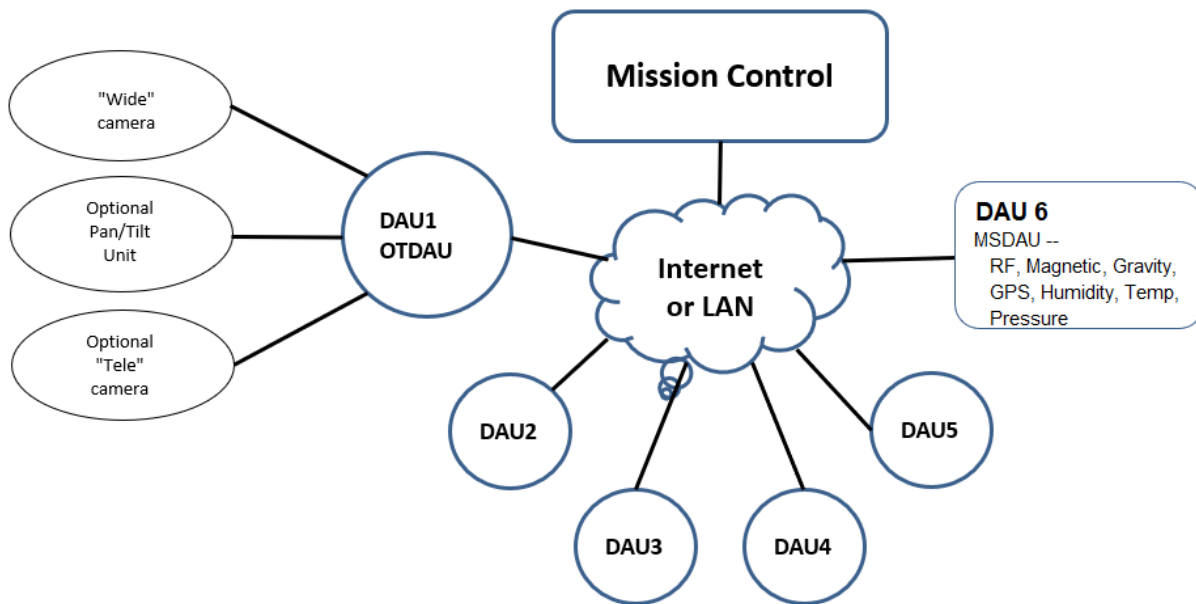

OTDAU also supports various motorized Pan/Tilt units which can carry sensors that have no PT capability on their own such as an IR or thermal camera, directional microphone or a radar antenna via the PTDAU.

OTDAU and MC software may be run on a computer local to cameras and MSDAUs, connecting to them directly or via a router. In this case, the computer, camera(s) and MSDAU(s) each connect to the same router. All these devices would be on the same Local Area Network (LAN).

Alternatively, any instance of OTDAU and/or MC could run on a computer remote from any connected camera(s) or MSDAU(s) and communicate with it via the Internet. Typically, the computer would be connected to a router that has an Internet connection. Each camera and MSDAU would gain access to the Internet by a wired or wireless connection to some other router. In this way, the computer(s) would access the cameras and MSDAUs via the Wide Area Network (WAN).

Any combinations of local and remote connections, working together for the same system are feasible. In addition, for systems that use more than one camera, such as triangulation, each instance of OTDAU software (one per camera) may run on the same computer or separate computers. MC software may run on the same computer as OTDAU or on a different computer. How many computers are used for a particular application will be a matter of convenience and speed which, in turn, depends on connection speeds and camera resolutions and frame rates.

## Functional Description

As shown in the configuration diagrams, a UFODAS system can take several forms, from simple to more complex, depending on available resources and data collection requirements.

In its simplest form, such a system may consist of a single PC with a fixed-lens USB camera pointed at a portion of the sky of interest. An object moving into the fixed field of view would be acquired, tracked and recorded. When a moving object enters the portion of the field defined by a bounding box (to reduce false identifications of motion in the background, such as foliage), the bounding box is reduced in size to surround the object and recording begins. The bounding box is made smaller to reduce the likelihood that, as the object moves past structures and foliage, it is less likely that the system will move its attention away from the object first acquired. When the object leaves the field of view, the system stops recording, returns the bounding box to its original location and size and waits again for another moving object. At the end of recording, several factors are used to determine if the object was truly of interest. These factors include the length of the capture sequence (very short may be due to birds, for instance) and image recognition of the object, such as an aircraft.

In a more capable configuration, a Pan/Tilt/Zoom (PTZ) IP camera is used. In this case, a similar acquisition sequence occurs except the system attempts to move the camera to keep the detected object in the center of the field of view (CFOV) so that zooming into the image will not send it out of frame. Zooming is incremental with a timeout between zooms to allow the system to bring the error distance from the object position to CFOV to below a set value. Again, the object will be continuously tracked and possibly zoomed into for as long as it remains visible.

At the end of each tracking sequence, data may optionally be sent via an email to up to three designated email addresses indicating that an event occurred, basic meta-data including time, location and system configuration as well as attached video or still frames of the event.

Triangulation is accomplished by combining the azimuth and elevation from two cameras tracking the same object. For this to be reasonably accurate, the location of each camera must be known. The system can determine the geolocation of each DAU from a street address or lat/lon values entered as part of its configuration. Alternately, an MSDAU can provide GPS location and accurate time. All that data is combined with the camera video and meta-data and included in the recording/upload. The magnetometer and accelerometer data can also be monitored for unusual disturbances prior to or during a video recording sequence. Such a disturbance may result in recording independent of or combined with camera data if a moving object is detected at the same time.

All functionality is set up and controlled by the MC and OTDAU Graphical User Interfaces (GUIs). These user interfaces are detailed in the following sections of this Guide.

A UFODAS system can take many forms to suit a particular user's needs. As illustrated below, it may consist of just the OTDAU software with one or two cameras. It may also include an MC communicating with any combination of up to six OTDAUs and MSDAUs. IP cameras and MSDAUs may be combined or separate and communicate with either a local computer on a LAN at the same location or to distant computers over the Internet.

**NOTE** that cameras and PTDAUs are interfaced to and controlled by instances of OTDAU. MC acquires camera data from OTDAUs and distinguishes between them by the unique port number the user can assign in each OTDAU System configuration.

Thus, a field investigator may only be responsible for installing a camera and/or MSDAU with power and an internet connection while the data those devices provide may be sampled by a computer at a distant researcher site.

Alternately, all the data acquisition equipment as well as the computer(s) running the OTDAU and MC software may be at the same site, communicating via a LAN on a single router.

Given the nature of IP connected devices, more than one computer can simultaneously monitor a video stream from one camera. Thus, a system may be constructed wherein a camera obtains PTZ control and data storage on one computer while several others monitor its video stream via OTDAU or another application such as Internet Explorer browser or the VLC video display software.

## Hardware Configuration Options

The UFODAS system architecture allows for many combinations of hardware and software to meet various data collection requirements and user budgets. Some of these configurations are illustrated in the diagrams below.

The most basic system would be just a PC computer running the OTDAU software with input from a USB webcam or a low-cost home-monitoring type of pan-tilt or PTZ camera. The camera may communicate with the computer via hardwire connection to the user's router or by WiFi.

A somewhat more sophisticated system might upgrade the camera to a security system quality PTZ camera with or without optical zoom. A hardwired Ethernet interface to a router is typical in this case. Camera power may be provided by an AC power supply or by a Power over Ethernet (PoE) Injector.

Note that, in contrast with other object recording systems that depend on higher-resolution cameras to detect object details, the OTDAU utilizes the combination of continuous tracking and optical zooming to optimize the number of sensor pixels used to image an object. Thus, for example, an object might occupy 100x100 pixels in a 4000x3000 pixel fixed-field image using a high-cost camera. The same object could be recorded in approximately 1400x1080 pixels in a typical 1080P (1920x1080) image. The UFODAS/OTDAU concept thus greatly improves on image quality as well as lowering system cost.

A single OTDAU computer may also use two cameras. One might be, for example, a USB fixed-field camera and the other a PTZ camera. In this configuration, an object detected with the fixed-field camera is used to direct the PTZ camera to point at in the general direction of the object. The PTZ camera then begins its own search for the object, detects it and then continuously tracks and zooms. In another mode, the PTZ camera's direction is continuously updated according to the object location in the FOV of the fixed camera. These two-camera modes are particularly effective when the fixed-field camera has an especially wide field of view, such as one with 360-degree optics (also known as a panoramic or "all-sky" camera).

The next stage of UFODAS system implementation may utilize two of the above OTDAU/camera systems and add the Mission Control (MC) software. In this configuration, one can monitor both OTDAUs and, when they both signal acquisition of a tracked target, continuously compute and record the triangulated geographic position and altitude of that target as it moves with respect to both camera systems.

The MC software can monitor and record data from up to six Data Acquisition Units (DAUs). DAUs may be OTDAUs for optical tracking but may also be MultiSensor DAUs (MSDAUs). Any combination of OTDAUs and MSDAUs may be locally (via LAN) or remotely (via the WAN or Internet) monitored and recorded by an MC.

Physical mounting of PTZ cameras may be accomplished in several ways depending on the available installation environment. A camera may be mounted by means of standard hardware provided by the camera manufacturer to a wall or pole. If the installation must be temporary or its position often moved, then an environmentally protected tripod mount for such a camera is available. The MSDAU alone may be tripod mounted or use Dahua standard mounting hardware for wall or pole mounting. The same mounting options are available for an MSDAU that includes a camera collocated on the same mounting adapter plate assembly.

Note that when configuring a data collection system, one can run more than one copy of OTDAU on a single computer with a single licensed copy. One can also combine one or more OTDAUs with MC on a single computer. The limit to this is the speed and memory of the PC, the number of such processes and the video resolution of the configured cameras. Some individual experimentation may be required to determine if the processing power of a particular combination will be sufficient for a user's application.

Please see the [ufodap.com](http://ufodap.com) website for the latest hardware, options and systems offered on the UFODAP Shop, accessed via the home page. The R&D section of [ufodap.com](http://ufodap.com) also provides a look at what capabilities may be offered in the future.

**Internet Accessible, single (or dual) camera**  
 Triangulation feasible if cameras widely spaced

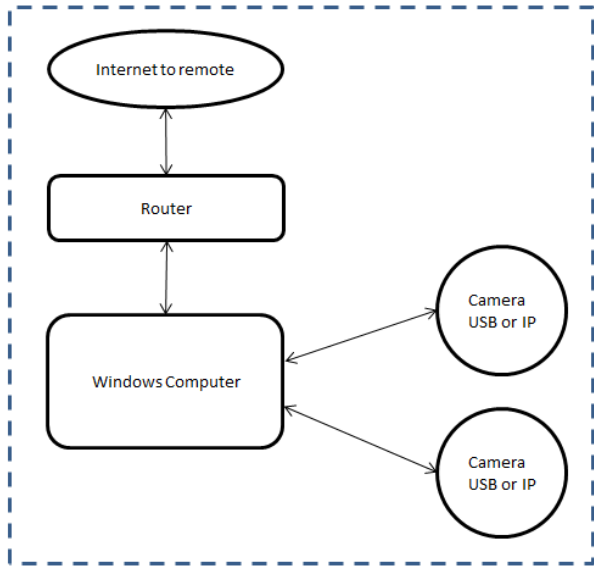

**Wide-Area system suitable for triangulation and data analysis**

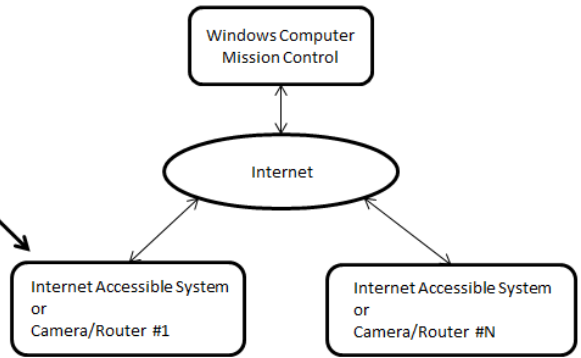

NOTE: "Camera USB or IP" may also include a Multi-Sensor Unit combined on a single Ethernet cable.

**Standalone data collection**

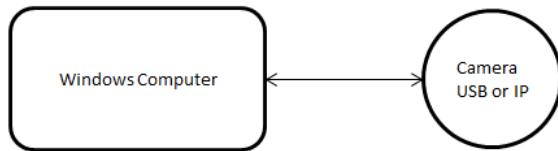

**Direct connect to internet, remote computation**

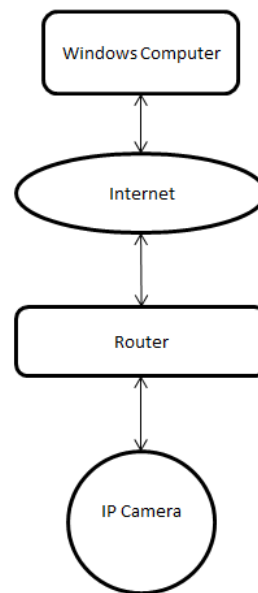

**Standalone, dual cameras (e.g., wide-angle fixed + telephoto)**

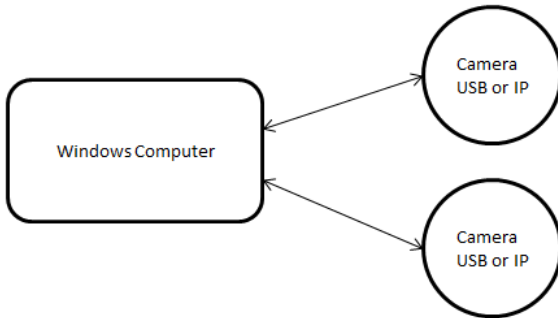

NOTE: "Camera USB or IP" may also include a Multi-Sensor Unit combined on a single Ethernet cable.  
 Cameras could be fixed, wide-angel, IP-PTZ, USB or USB from converted composite video, e.g., an all-sky camera

## Mission Control (MC)

### Introduction

The Mission Control (MC) software provides a means to bring together, in one location, data from up to six remote DAUs. If two of those DAUs are OTDAUs then MC can triangulate the location, azimuth and elevation data acquired from those DAUs to provide a real-time view of the geolocation, altitude, size and velocity of an object both DAUs are tracking.

Each DAU could be, in any combination:

- An OTDAU with one or two cameras
- An MSDAU with optional external USB and WiFi connected sensors
- A PTDAU via an instance of OTDAU
- Other types of DAUs which would consist of a version of the Raspberry Pi with its OS and firmware plus internal or external specialized sensors such as radar or acoustic devices.

The MC displays on a single main screen data from all the connected DAUs along with thumbnails of the video from any OTDAUs. It also provides a real-time updated Google Map showing the locations of all DAUs, with camera bearings and triangulation results. Alternately, a real-time, full frame-rate video stream from an OTDAU tracking camera, moving graph of MSDAU data or an MSDAU RF spectrum may be selected to replace the map display. The user can rapidly switch between any of these data sources. Controls are provided to move the center of the map and zoom the map in or out for detailed location analysis.

MC also can record to a local disk file all the continuously collected OTDAU and MSDAU data, the map image and up to two camera feeds. Camera video is saved as avi files while other data is saved as CSV files suitable for input to Excel for analysis.

## MC Quick Start Guide

The following is a brief list of steps to start and run an MC Mission.

- Power up an MSDAU and verify or set its address to 144.
- Open OTDAU and Load the System configuration “test-aerobatics” with assigned port 51000.
- Open MC by double-clicking on the MC icon on your desktop, resulting in:

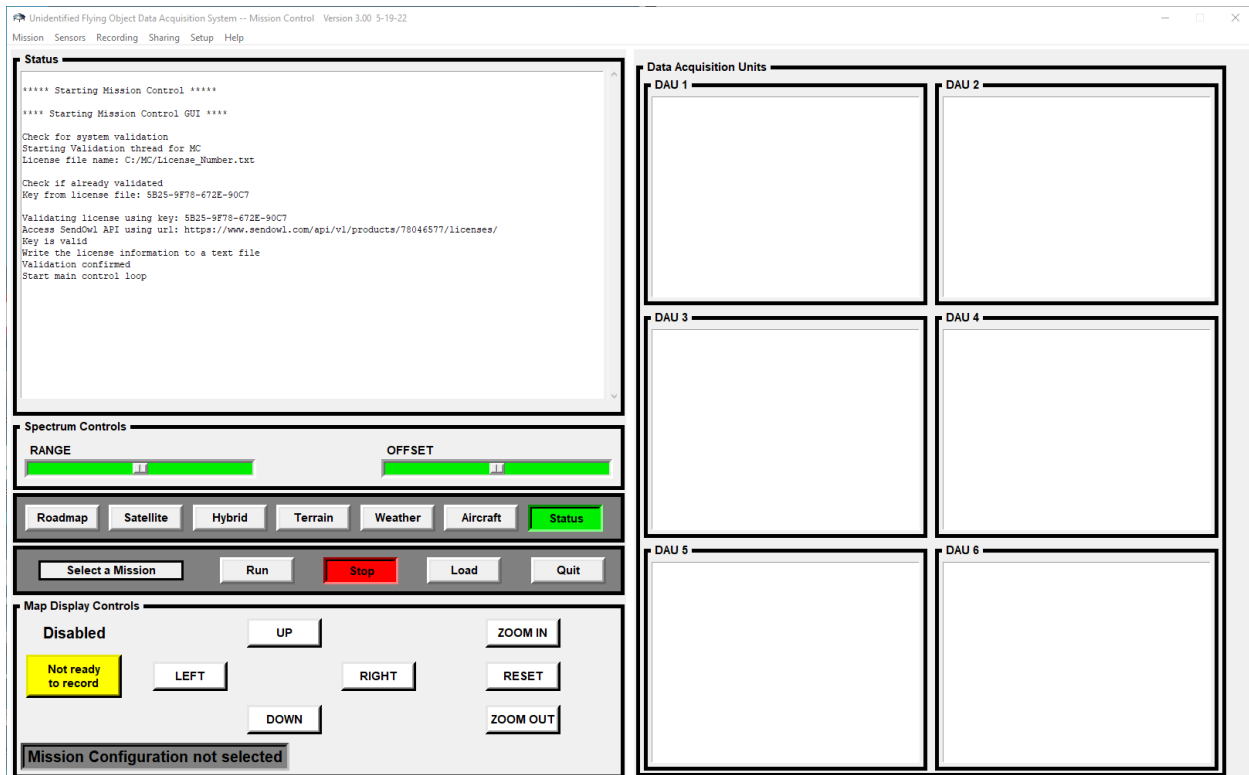

- Click Mission. This will bring up the Mission Configuration form.
- Click on Open and then double-click on the desired mission file name, in this case, “mission-pccam1-ms1.json. This mission monitors one instance of OTDAU software with port 51000 and one MSDAU at address 192.168.1.144. The main display status box should now show “Ready to load”.
- Click Close Window. To the right of the status box, click the Load button. Data from the selected DAUs will appear in the Data Acquisition Units display windows. The status box will show “Ready to run”, the Stop button will illuminate. A Google map will appear which shows the location of the DAUs, as shown below.

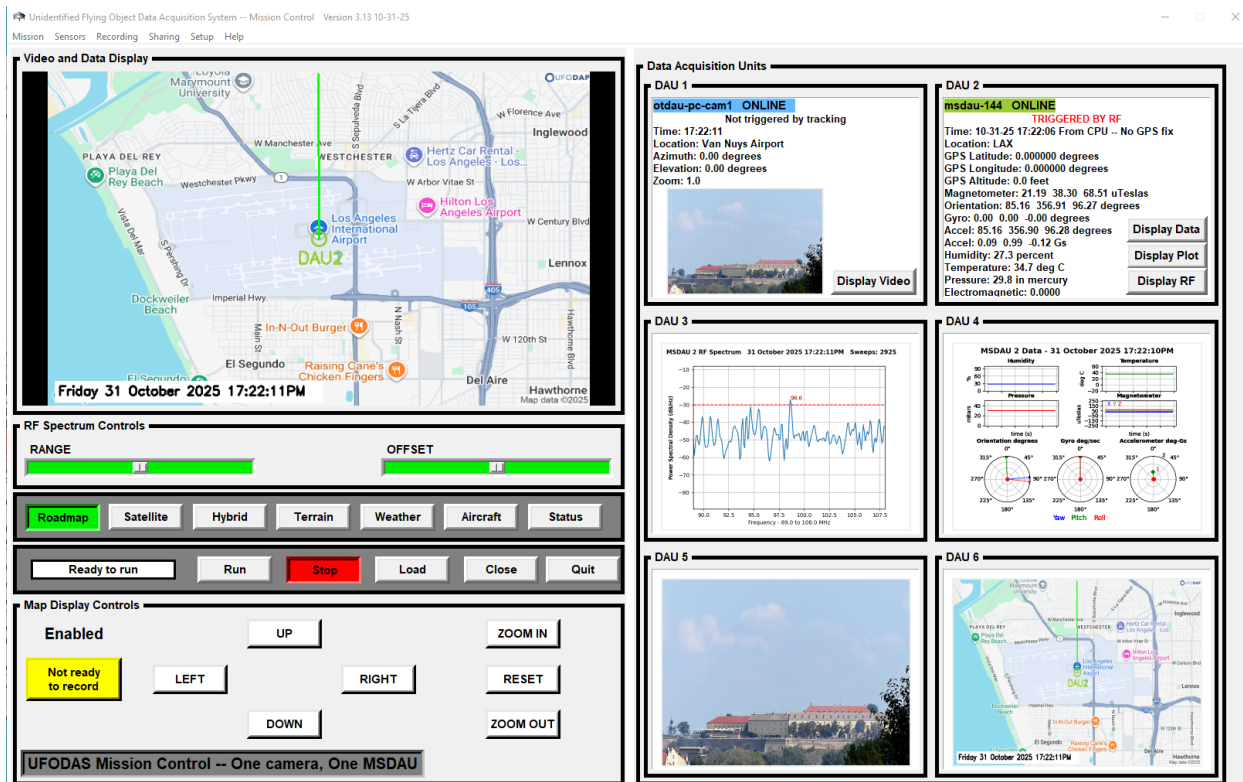

- Click the Display Plot button to see real-time MSDAU data or click Display RF, Aircraft for a chart of nearby aircraft or, in the MSDAU box, Display RF to see a real-time RF spectrum plot.
- Recording options may be selected at any time after opening the mission configuration file.
- Clicking the Run button would enable any recording options selected if one or both of the DAUs become triggered.

After selecting Display Plot:

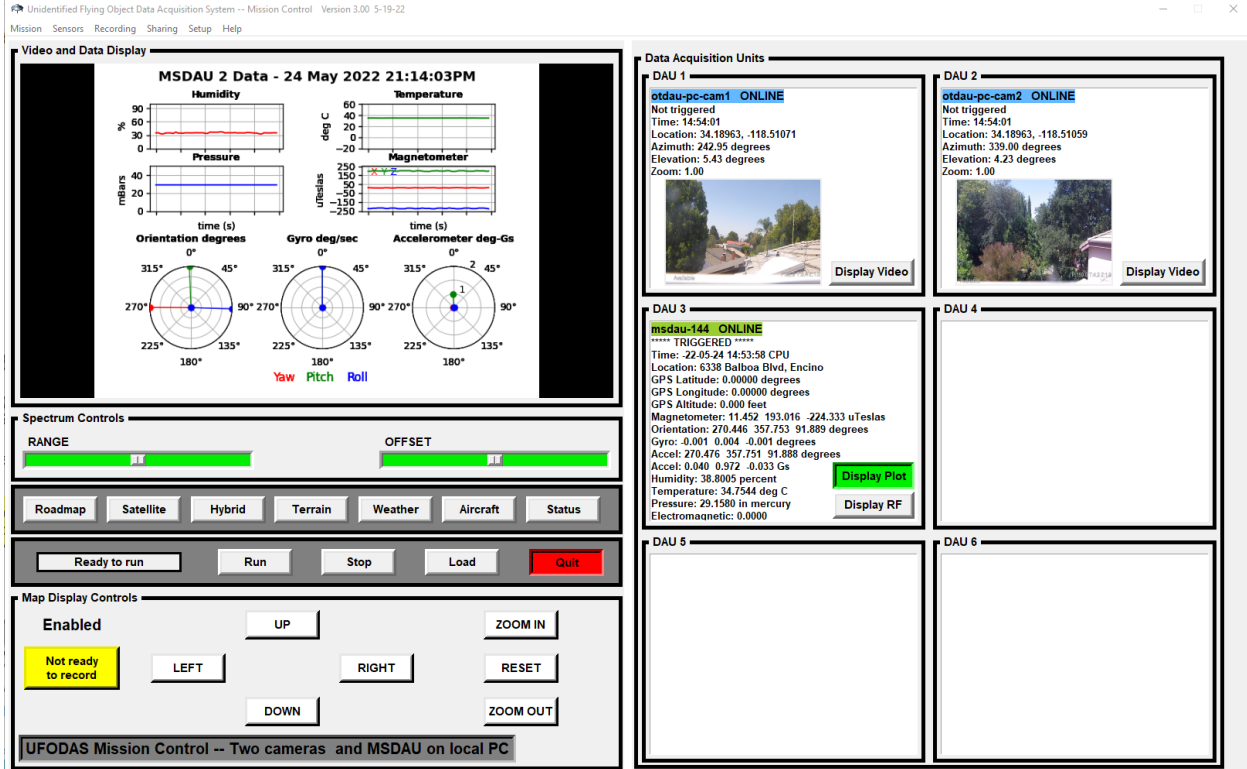

The plot is continuously updated with the following data from the MSDAU:

- Relative humidity in %
- Temperature in degrees C – NOTE: This is the internal temperature of the MSDAU useful as a measure of its hardware status and longevity. It is not outside environmental temperature.
- Pressure in milliBars
- Magnetometer in microTeslas for each of the X, Y and Z directions
- Orientation in degrees of the MSDAU for each axis -- yaw, pitch and roll
- Gyro (AC accelerometer) in degrees/second for each axis -- yaw, pitch and roll
- Accelerometer (DC) in degrees for each axis of yaw, pitch and roll. The length of each of the axis lines indicates acceleration in Gs

After selecting Display RF:



The minimum and maximum frequencies to be swept and the peak detection level are selected in the MSDAU Configuration, as shown below.

Display with trigger level of -30 dB and anomalous peaks for fmin and fmax that encompasses the entire FM broadcast band:

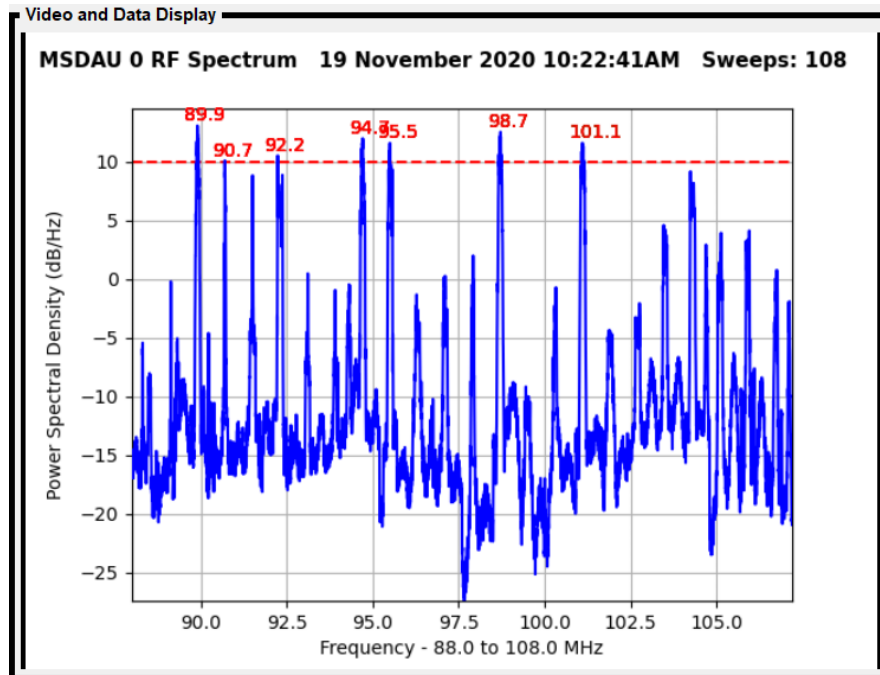

The peak detection level is a value in dB which is displayed as a dashed red line. Initially, the system makes several measurements of the specified RF band and retains that as a background level. Subsequently, if any energy is detected that exceeds that level, then those peak values are highlighted with their specific values displayed in red, as shown above. This is also shown in the DAU display as “TRIGGERED BY RF”.

A trigger condition results from any frequency values exceeding the selected peak level during a Run. If an MSDAU is selected to be a Recording Trigger then this trigger condition, as well as for any sensor value above the percent increase selection, causes the system to begin recording all data selected to be recorded, as shown in the Mission Configuration below.

For example, the Mission configuration for the mission-pccam1-ms1 mission above might be as shown below.

Description	Start time	Stop time	Enable Sound
UFODAS Mission Control -- One camera, One MSDAU	07:00:00	23:00:00	<input checked="" type="checkbox"/>
Data Acquisition Unit	Recording Trigger	Associated DAU	
DAU 1: otdau-pc-cam1	<input checked="" type="checkbox"/>	2	
DAU 2: msdau-144	<input checked="" type="checkbox"/>		
DAU 3: display-2-rf	<input type="checkbox"/>		
DAU 4: display-2-plot	<input type="checkbox"/>		
DAU 5: display-1-video	<input type="checkbox"/>		
DAU 6: display-1-map	<input type="checkbox"/>		

Buttons: New, Open, Save, Save As, Close File, Close Window

## Mission Control menus and displays

Operating the Mission Control application requires the user to set up several mission configurations. These configurations are entered from forms selected by the following titles found at the top of the MC main window:

- Mission
- Sensors
- Recording
- Sharing
- Setup
- Help

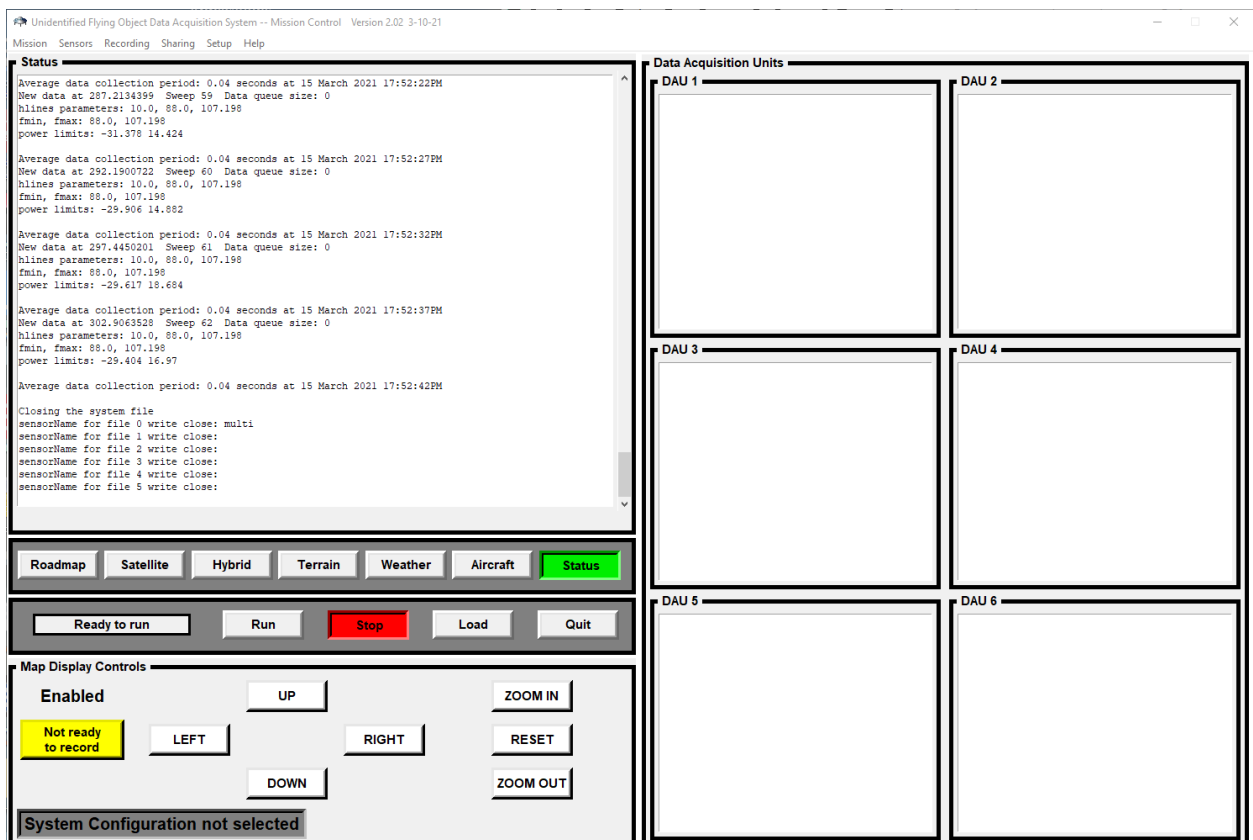

Mission Control application GUI prior to mission configuration selection.

A default (CGI UFO) photo is shown when the system has not been configured and thus there is nothing to display.

Up to six sensors or Data Acquisition Units (DAUs) are supported by the mission configuration. Each of the six boxes not used for a DAU can be used to display several types of data from other DAUs.

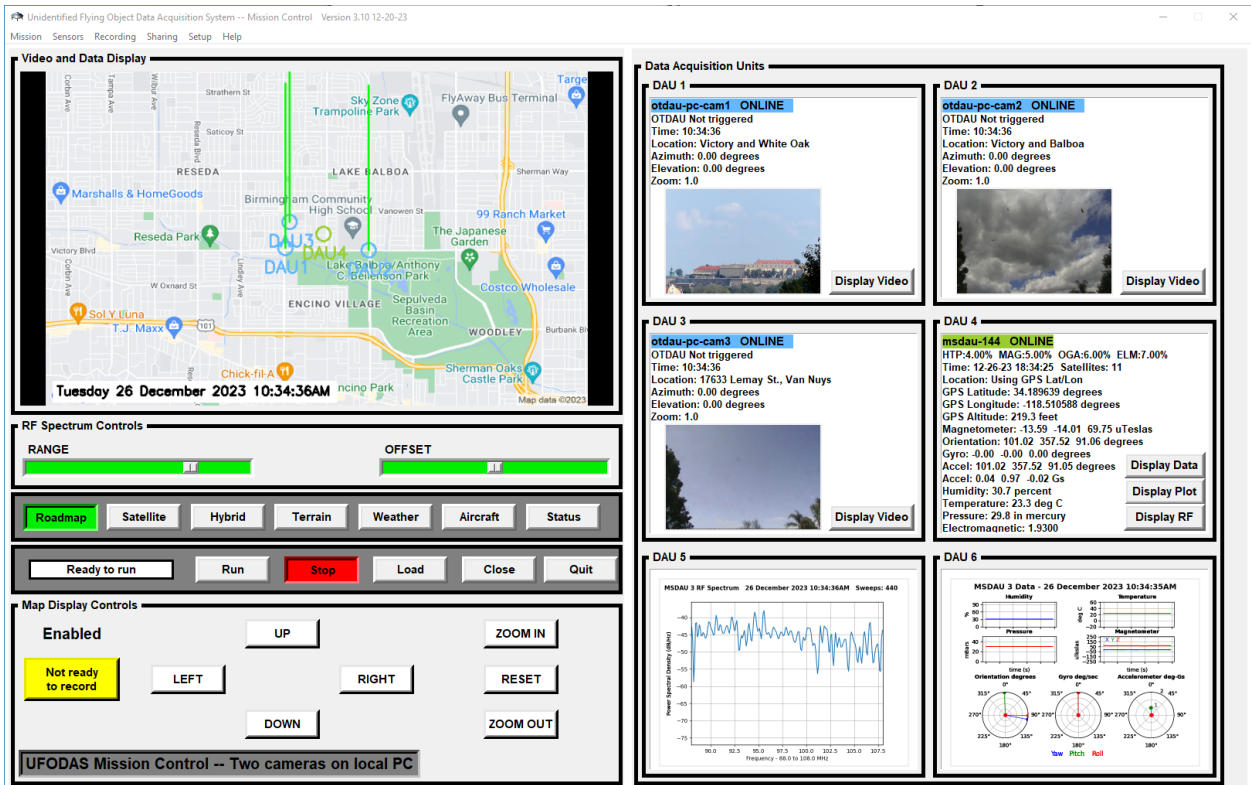

MC after configuration with three PTZ cameras, MSDAU and corresponding Sensor Units with optional additional data displays in unused DAU positions.

Pins on the Google Map are color coded to the associated sensor and show the Sensor number.

The MSDAU is located by GPS because it has sufficient satellites for a fix. Since the Mission configuration did not specify that the location of the cameras (each instance of OTDAU), was not Associated with the location of the MSDAU. The location of each camera is shown at its default location, specified manually in the Sensor > OTDAU window for each.

Both cameras are pointing in the same direction as shown by the green bearing paths.

The location shown of an MSDAU will be its longitude/latitude as derived from its internal GPS receiver if the receiver has achieved a fix on at least four satellites. Otherwise, the location will be the one entered as the Location in the MSDAU configuration.

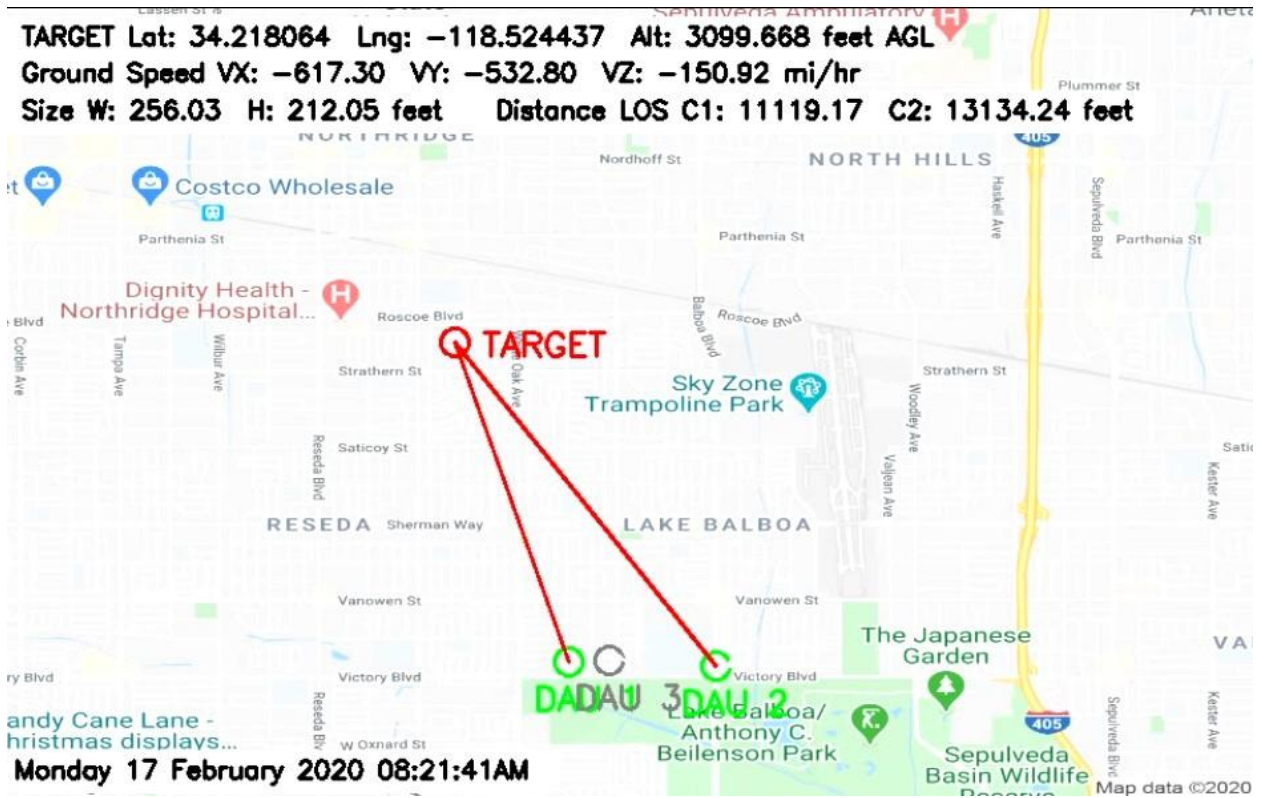

**MC with Google roadmap after a target has been acquired by both cameras and triangulated.** The target latitude, longitude and altitude are now displayed.

Real-time recording of the map, both camera video streams and all the digital meta-data from all four sensors would start recording, if selected.

When the target can no longer be triangulated, the system may optionally send a status email with map frames and other data to up to three email addresses.

## System Status controls

The contents of the System Status box are controlled by a group of six buttons below it.

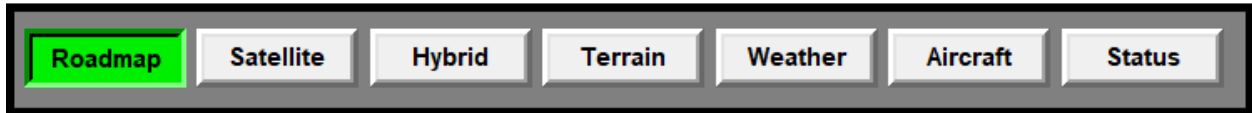

The Roadmap, Satellite, Hybrid and Terrain buttons govern what kind of Google map display is shown.

The Status button, the initial default, selects ongoing MC program status messages. Prior messages no longer in the window may be viewed when MC has been Stopped. Messages may be scrolled by using your mouse wheel or the slider on the right side of the Status display.

## Weather data collection

The Weather button displays a list of weather conditions at each DAU location, as shown below.

Atmospheric Data per DAU		UFODAP Mission Control				15 March 2021 18:15:26PM	
Data Item	DAU1	DAU2	DAU3	DAU4	DAU5	DAU6	
City	N/R	New York	Toronto	Portland	Hooper	Houston	
State	Colorado	New York	Ontario	Oregon	Colorado	Texas	
Time of calculation	18:15:25	18:15:26	18:15:00	18:13:46	18:15:28	18:12:28	
Local Time	19:15:23	21:15:23	21:15:24	18:15:25	19:15:25	20:15:26	
Sunrise Time	06:14:04	04:07:12	04:29:20	07:22:38	06:14:10	05:30:59	
Sunset Time	18:10:28	16:02:21	16:23:30	19:16:28	18:10:33	17:29:43	
Status	few clouds	clear sky	overcast clo	overcast clo	clear sky	few clouds	
Wind Speed - m/s	5.66	3.60	3.67	2.06	8.75	4.12	
Wind Speed - mi/hr	12.66	8.05	8.21	4.61	19.57	9.22	
Wind Gust - m/s	12.86	7.72	5.20	N/R	11.32	N/R	
Wind Gust - mi/hr	28.77	17.27	11.63	N/R	25.32	N/R	
Wind Dir - deg	270.00	300.00	116.00	300.00	240.00	150.00	
Humidity - %	49.00	17.00	43.00	49.00	42.00	83.00	
Temperature - C	5.08	1.41	-2.82	6.14	5.07	23.23	
Temperature - F	41.14	34.54	26.92	43.05	41.13	73.81	
Pressure - hPa	1009.00	1027.00	1028.00	1022.00	1009.00	1011.00	
Pressure - inHg	29.80	30.33	30.36	30.18	29.80	29.85	
Visibility - m	10000.00	10000.00	10000.00	10000.00	10000.00	10000.00	
Rain - mm/hr	N/R	N/R	N/R	N/R	N/R	N/R	
Snow - mm/hr	N/R	N/R	N/R	N/R	N/R	N/R	
Clouds - %	20.00	1.00	100.00	90.00	1.00	20.00	

N/R -- Not Reported

New data is available every two hours or less

Weather data may be saved to a CSV format file by selecting the associated Recording Option. This saves all weather parameters at the time a trigger condition occurs, which also starts all recording options.

## Aircraft flight data collection

The Aircraft button displays a list of aircraft information for all flights within a 10 mile on-side area surrounding DAU1.

Data Item	Flight 1	Flight 2	Flight 3	Flight 4	Flight 5	Flight 6
ICAO transpdr adds	a22e7e	acd27a	a214a0	4d23b7	a97a67	
Callsign	N24JR	N925TV	N233LA	VJT712	N71HD	
Origin Country	United State	United State	United State	Malta	United State	
Last Position Time	22:35:07	22:35:08	22:35:07	22:35:01	22:35:07	
Last Contact Time	22:35:07	22:35:08	22:35:07	22:35:07	22:35:07	
Longitude	-118.50	-118.38	-118.35	-118.49	-118.34	
Latitude	34.28	34.09	34.07	34.22	34.11	
Barometric Alt - m	708.66	426.72	182.88	N/R	411.48	
Surface Report	False	False	False	True	False	
Velocity - m/s	70.19	1.15	28.00	0.00	9.16	
True Track - deg	175.38	206.57	69.57	87.19	51.84	
Vertical Rate - m/s	-4.55	0.00	1.63	N/R	0.65	
Sensor IDs	N/R	N/R	N/R	N/R	N/R	
Geometric Alt - m	723.90	396.24	175.26	N/R	403.86	
Squawk Code	N/R	N/R	N/R	N/R	N/R	
Special Purpose Ind	False	False	False	False	False	
Position Source	ADS-B	ADS-B	ADS-B	ADS-B	ADS-B	
Aircraft Category	No informat	No informat	No informat	No informat	No informat	
Category line 2	ion at all	ion at all	ion at all	ion at all	ion at all	

N/R -- Not Reported      Typical data latency is ~10s to 2min      5 of 5 flights shown  
 Reporting area is a rectangle, 10 mi/side, centered on the location of DAU1  
 Data is from The OpenSky Network, <https://opensky-network.org>

Aircraft flight information is listed for the first six flights of the total flight data available. Flight data includes each aircraft's call sign, time of last position measurement, whether it is on the ground or in the air (Surface Report), absolute (Geometric) altitude, etc. The position source is typically from Automatic Dependent Surveillance–Broadcast (ADS-B) receivers but may also be derived from Multilateration (MLAT) or All Purpose Structured Eurocontrol Surveillance Information Exchange (ASTERIX) data.

ADS-B message decoding and display also provides the Aircraft Category. The category may be one of 25 values including “No information at all”, “Small (15500 to 75000 lbs.)”, “Glider / sailplane”, etc.

Detailed information about how flight data is collected and what aircraft may or may not be displayed is available at:

<https://www.opensky-network.org>

After at least one set of aircraft data is collected, aircraft locations and call signs are shown on the map, as in the display, below.

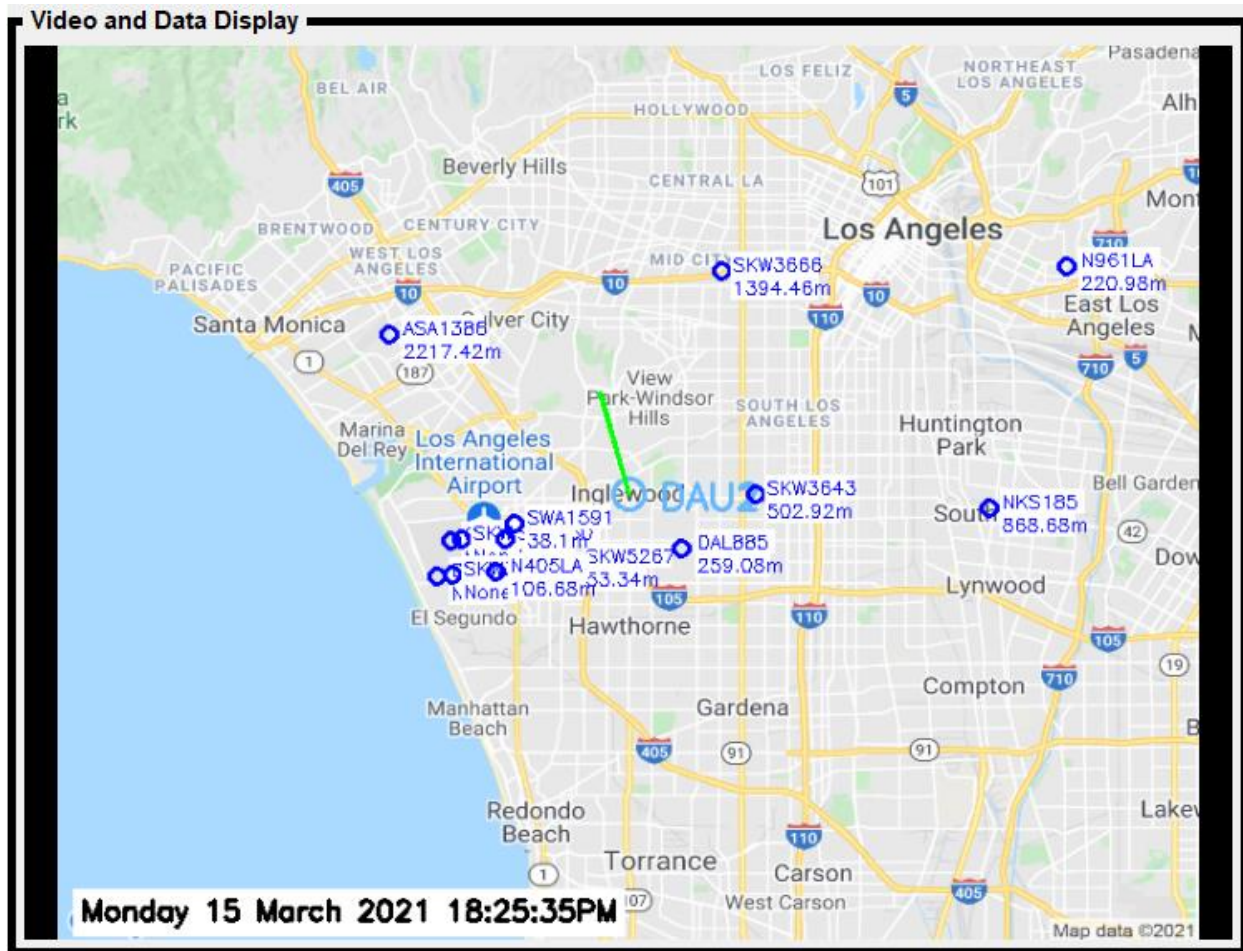

The call sign and geometric altitude are also geolocated and displayed on the map. Each such indicator moves whenever the data is updated, typically every 10 seconds.

Aircraft flight data may be saved to a CSV format file by selecting the associated Recording Option. This saves flight parameters for all aircraft at the time a trigger condition occurs, which starts all recording options

**NOTE:** OpenSky aircraft data can only be sampled 400 times/day. To prevent unnecessary exhausting this limit, aircraft data is only sampled either once per selection of the Aircraft display or every 10 seconds during Run and a trigger condition. The first line of the display indicates when sampling occurs. You will see changes to the aircraft indicators on the map when sampling picks up new values.

## Operating controls

A status box and four buttons are located below the System Status controls.



From left to right these are:

**Status Box** – Displays a message indicating the current MC operational state. These messages include:

Stopped (as shown above)

Ready to load

Waiting for DAUs

Ready to run

Running

\*\*\* TARGET ACQUIRED \*\*\*

\*\*\* Recording \*\*\*

Recording stopped

**Run** – Click this button to start monitoring DAUs for triggered state(s) and updating the map display.

**Load** – Click to load the selected Mission configuration, update the DAU displays and get ready to Run.

**Close** – Close the current Mission.

**Quit** – Terminate MC program execution.

## Map Controls

The Map Controls portion of the display is enabled for user control when the system has been loaded with a Mission Configuration but is not in the Run state. Whether these controls are Enabled or Disabled is indicated under the Map Controls title.

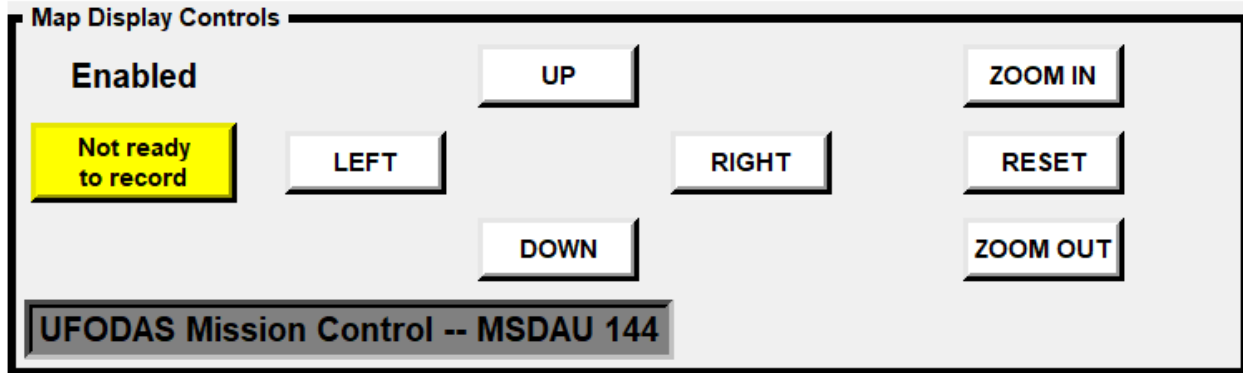

When Map Controls are enabled, the user may move the portion of the displayed map up, down, left or right by clicking on the corresponding buttons. Holding down the left mouse button while over a direction allows continuous movement in that direction.

The map may also be zoomed in or out by clicking on the zoom in or zoom out buttons.

Clicking on Reset will return the map to the original size and location prior to any direction or zoom command.

The contents of the box in the lower left corner reflects the Mission Description entered in the Mission Configuration window.

## Mission Setup

Setting up an MC for a particular mission involves the following steps:

1. Determine which DAUs will be used for the mission.
2. Verify or set up those DAUs as Sensors in Sensor Configurations.
3. For each OTDAU computer, calibrate the camera position. This is accomplished by manually moving the camera via the PTZ controls to set the pan angle (azimuth) due North and the tilt angle (elevation) at the horizon. Then in the OTDAU Setup menu, click on “Set Pan and Tilt offsets” and then Save. This will create an offset to the actual camera pan/tilt angles, zeroing them out at this initial position and moving the green camera azimuth indicator line to point North.
4. For each OTDAU computer, set the initial Home position of the camera to the field of interest and any other necessary parameters and then Run the tracking process.
5. On the MC, select or configure a Mission configuration that uses the needed DAUs. Be sure to set the Recording and Sharing options as required before Running. If MSDAUs are used, adjust the triggering sensitivity by changing the Trigger level percent in the Setup Options menu.
6. Run the Mission and verify via the right-side displays that data and video is streaming to the MC from the DAUs and that the MSDAU trigger level is not too low (creating false triggers). Use the MSDAU Display Data button to review trigger levels and current background “noise”. Stop the Mission and adjust as necessary.

**Note** that the function of Run is to enable recording and enable triangulation. Data can be checked for any DAU prior to Run.

All the MC parameters and menus are described below.

## Mission Configuration

DAU	Recording Trigger	Associated Sensor
Sensor 1: <input type="text" value="otdau-pc-cam1"/>	<input checked="" type="checkbox"/>	<input type="text" value="2"/>
Sensor 2: <input type="text" value="msdau-145"/>	<input type="checkbox"/>	<input type="text"/>
Sensor 3: <input type="text" value="otdau-pc-cam2"/>	<input checked="" type="checkbox"/>	<input type="text" value="4"/>
Sensor 4: <input type="text" value="msdau-144"/>	<input type="checkbox"/>	<input type="text"/>
Sensor 5: <input type="text"/>	<input type="checkbox"/>	<input type="text"/>
Sensor 6: <input type="text"/>	<input type="checkbox"/>	<input type="text"/>

Buttons: New, Open, Save, Save As, Close File, Close Window

An MC is configured for operation for a particular application by setting several parameters via the Mission Configuration window. This window is accessed by clicking on the System tab at the top of the main window.

This window shows all the available system configurations. To select one, click it once and then click on Open or double click your selection.

A different configuration may be selected by clicking on Close File, then Open and selecting a different configuration.

It is often convenient to create a new configuration by opening an existing one, modifying it, and then clicking on Save As. The same file list will appear but the file name, at the bottom will be highlighted and contain just “.json”. Add the rest of the desired name before the “.”, for example, “mission-mycam-ms1.json” might be used to describe a configuration with two DAUs – mycam referencing an instance of OTDAU and ms1 referring to an MSDAU.

After selecting a system configuration, all its parameters are available for inspection or modification via the System, Cameras, Tracking, Recording, Sharing and Setup menus. DAUs selected for Sensors 1 thru 6 have configurations accessed via the Sensors tab.

System Configuration form entries are:

**Description** -- User-provided description of the configuration.

**Start time** – The time in 24-hour format at which the system will start to run if enabled to Run. Start time and Stop time are particularly useful when, for example, a sensor may false trigger or a camera used is such that the image will start to pixelate under low-light conditions causing false motion triggering.

**Stop time** – The time in 24-hour format at which the system will stop running.

**Enable Sound** -- Enable a system sound when a recording triggering condition occurs.

**DAU** – Up to six DAUs of any type may be specified. During Run time, each DAU will be monitored and its data displayed in the right panel. Unused DAU display boxes may also be used for additional data displays, as described below.

**Recording Trigger** – Enables the system to start recording if the associated DAU sends MC a trigger signal. Recording is stopped if all such DAU are no longer triggered for two seconds. This delay prevents intermittent trigger conditions from creating too many recorded folders.

**Associated DAU** – Tells MC to use the location of the Associated DAU (1 to 6) as the location of the DAU rather than use the geolocated position of the DAU derived from the location entered in the DAU sensor configuration, typically a street address. This option may be used to locate a camera based on the GPS location of an MSDAU.

You can also use DAU 1-6 display areas for other data displays. In a Mission configuration, in an otherwise unused DAU entry, enter the text “display-n-type” where n is the DAU which is the source for the data and type is the keyword “map”, “video”, “plot” or “rf”. For example, to display the RF Spectrum from DAU 2 in position DAU5 enter “display-2-rf” in the DAU2 line of the list of Data Acquisition Units in the Mission Configuration window. Entry errors or references to a DAU which cannot be the data source will be ignored or generate an error message. When using “map”, n can be any valid number.

For example, this Mission Configuration –

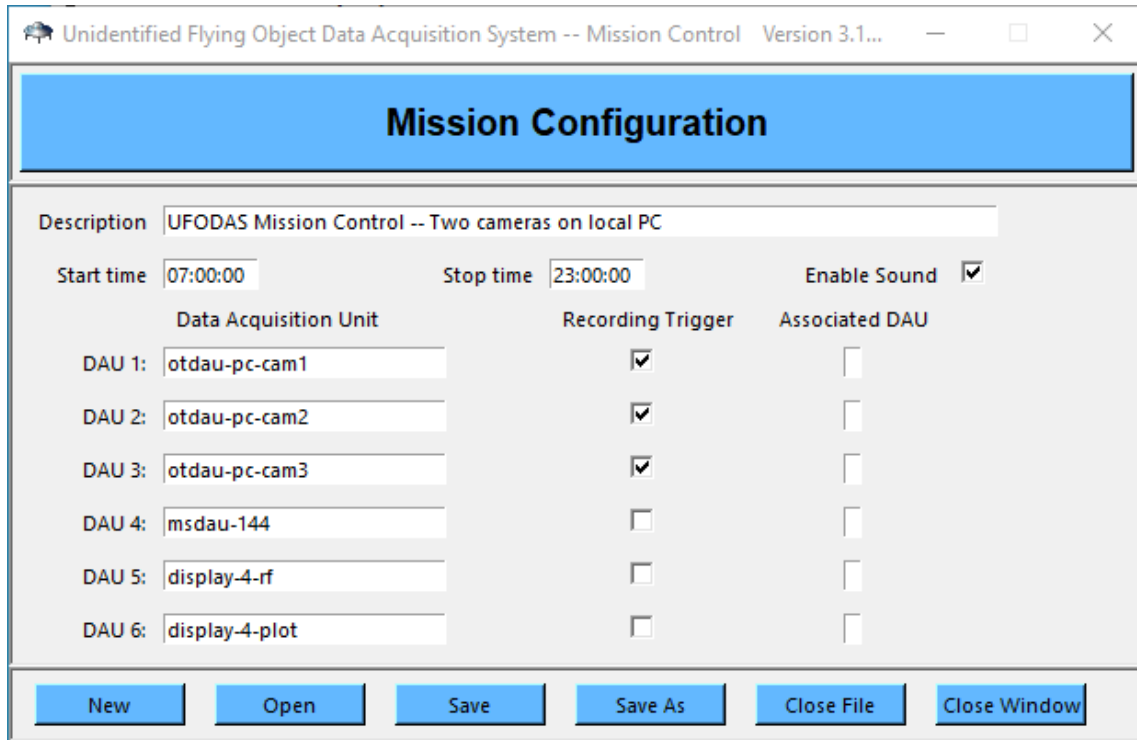

Results in the following set of displays:

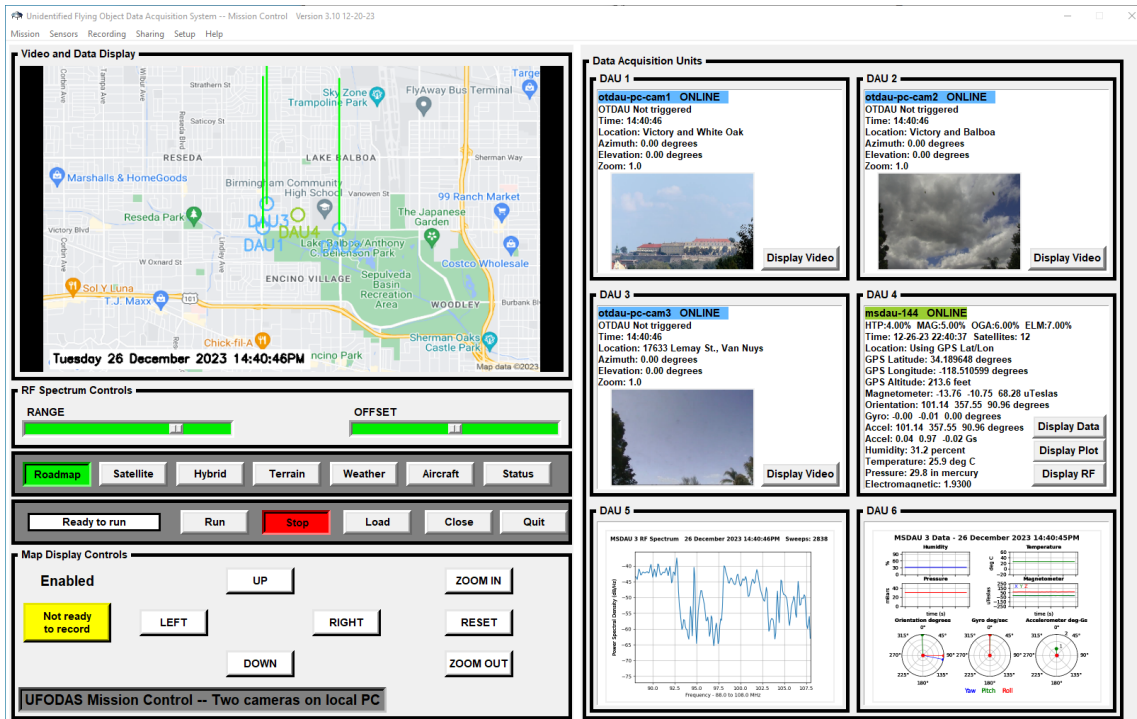

## Sensor OTDAU Configuration

Clicking the Sensor tab and then OTDAU Configurations brings up the OTDAU Configuration window

The screenshot shows a window titled "Unidentified Flying Object Data Acquisition System -- Mission Control". The main content area is titled "OTDAU Configuration". It contains several input fields and buttons:

- Description**: A text input field.
- File Name**: A text input field.
- Location**: A text input field.
- Type**: A text input field.
- Video FPS**: A checkbox.
- IP Address**: A text input field with a note below it: "Use 127.0.0.1 if OTDAU running on same computer as MC".
- Port**: A text input field with a note below it: "Unique value for each instance of OTDAU on a computer".

At the bottom of the window, there are five buttons: "New", "Open", "Save", "Save As", and "Close Window".

**Description** -- User-provided description of the configuration.

**File Name** – The name of the file in which this configuration is stored. Not user editable.

**Location** – The physical location of the DAU. Used to geolocate the DAU on Google Maps. May be in any form acceptable to Google Maps such as a street address, intersection or longitude/latitude.

**Type** – The type of DAU. Must be either “track” if an OTDAU or “sensor” if an MSDAU.

**Video FPS** – The frame rate of the camera used by the referenced OTDAU.

**IP** – The IP address of the computer running the referenced copy of OTDAU. For instances of OTDAU running on the same computer that is running MC, use 127.0.0.1. If OTDAU is running on a different computer (on the same LAN or port-forwarded from a different LAN), use that computer’s static address. For example, 192.168.1.37. This number would have been entered on the OTDAU host computer as a static IPv4

address. See below for how to give your computer a static IP address instead of using DHCP.

**Port** – The port number representing the instance of OTDAU running on this computer. For example – 51000, 52000, 53000... This is the port number entered in the System Configuration, Computer port field of the configuration running on the desired OTDAU. Note that one computer can run multiple copies of OTDAU, each with its own camera(s). In that case, each OTDAU configuration should have a different Computer Port number, but the IP address would be the same.

**NOTE:** The TCP server configuration for each port is preserved after first use so that when any System configuration is Loaded, either a new server is started if its port had not been used or a previous one corresponding to the required port is reused. This ensures that when an MC Mission is waiting for a particular port, it connects to the correct instance of OTDAU.

### **Control buttons**

**New** – Opens a file selection window but has no other effect. Not used in this version release. Use Save As instead to create a new configuration.

**Open configuration** – Opens a window into the System configuration file folder. Select a configuration by either double clicking on an entry or clicking one once and then click on Open. The selected configuration must be Loaded prior to use after Opening it. Note that the Load button may be used before or after the System Configuration window is closed by the Close Window button. See the Load button, below.

**Save** – Saves the current settings as part of the currently loaded System configuration.

**Save As** – Opens a window into the System configuration file folder. Saves the current settings as the System configuration but with a new name selected in this window. It is very useful to Open an existing configuration, modify its values, and then Save As with a new name to create a new configuration.

**Close Window** – Closes the configuration window.

**NOTE:** Opening Sensors > OTDAU or >MSDAU will open the last sensor of the same type selected without having to use Open.

## Sensors MSDAU Configuration

Clicking the Sensor tab and then MSDAU Configurations brings up the MSDAU Configuration window:

Unidentified Flying Object Data Acquisition System -- Missio...

### MSDAU Configuration

Description

File Name

Location

Type

IP  Port

#### Trigger Control levels in percent deviation from average

Trigger level for Temperature, Pressure, Humidity	<input type="text" value="0.0"/>
Trigger level for Magnetometer and Accelerometer Gs	<input type="text" value="0.0"/>
Trigger level for Orientation, Gyro and Accelerometer degs	<input type="text" value="0.0"/>
Trigger level for Electromagnetic (Tri-Field Meter)	<input type="text" value="0.0"/>

#### RF Spectrum Analyzer

Minimum frequency, MHz	<input type="text" value="0.0"/>	Maximum frequency, MHz	<input type="text" value="0.0"/>
Peak detection level in dB	<input type="text" value="0.0"/>		
RF amplifier gain For Standard SDR: -40 to 40 For UWB SDR: 0 to 102	<input type="text" value="0.0"/>	Lowpass filter cutoff in Hz	<input type="text" value="0.0"/>

The Description and other fields in the top box are the same as described for an OTDAU, above.

**Trigger level percent** – Percent change from nominal baseline value that will cause a trigger condition. The same level is applied to all MSDAU sensors.

Due to different background noise levels and absolute magnitudes of different classes (groups) of sensors, there are four trigger levels instead of one. Trigger level may be specified for Humidity/Temperature/Pressure/ (HTP), Magnetometer (MAG), Orientation/Gyro/Accelerometer (OGA) and Electromagnetic (ELM – the external USB interface for a Tri-Field meter). The group abbreviations and their values are shown on the second line of each MSDAU data display. A single trigger condition from each MSDAU occurs if any group is in a triggered state or there is an RF trigger condition due to an RF spectrum peak(s) exceeding the Peak detection level. For each data group, a trigger will occur if the absolute value of the difference between the currently sampled value of any value in that group and its running average (10 samples) exceeds a trigger level. The trigger level for each value is a percentage of the full-scale range of data for that value. The full-scale range for each group is: HTP – H:100, T:50, P:31, MAG and OGA – 360 (except accel raw is 2) and ELM – 100. Setting too low a trigger level will cause continuous triggering due to background noise. A sensor group will never trigger if the associated level is set too high. Using the MSDAU Display Data selection, set each level based on observation of nominal, settled conditions and select a value above that.

For values collected as angles, a triggering condition exists when the difference between the current and last input signal is the trigger level above the running average of such differences. Triggering will occur both when the signal abnormally peaks and when it drops back to the average. As before, trigger levels are the product of the trigger % entered in MSDAU Sensor Configuration and the sensor's full-scale value. The Data display column for Avg has been changed to Deviation which shows the difference between the current value of a Data Item and running average of the data for non-angular sensors. It shows the mean value of the deviation from the current value for angular sensors.

**RF Spectrum minimum frequency** – Starting frequency for RF spectrum sweeps.

**RF Spectrum maximum frequency** – Ending frequency for RF spectrum sweeps.

**RF Spectrum peak detection level in dB** – After an initial baseline sampling period, any RF energy above this level will cause a trigger condition.

## **Control buttons**

**New** –Opens a file selection window but has no other effect. Not used in this version release. Use Save As instead to create a new configuration.

**Open configuration** – Opens a window into the System configuration file folder. Select a configuration by either double clicking on an entry or clicking one once and then click on Open. The selected configuration must be Loaded prior to use after Opening it. Note that the Load button may be used before or after the System Configuration window is closed by the Close Window button. See the Load button, below.

**Save** – Saves the current settings as part of the currently loaded System configuration.

**Save As** – Opens a window into the System configuration file folder. Saves the current settings as the System configuration but with a new name selected in this window. It is very useful to Open an existing configuration, modify its values, and then Save As with a new name to create a new configuration.

**Close Window** – Closes the configuration window.

**NOTE:** The RF Spectrum Range and Offset slider controls now revert to the last setting for each MSDAU when Display RF is selected for it. These settings are not saved with the Mission but are retained between Mission selections.

**NOTE:** Full spectrum refresh is composed of concatenated sections of bandwidth with successive center frequencies. Each section can only cover the maximum bandwidth per sweep of the hardware, i.e., ~20MHz. Thus, the narrower the requested frequency range, the faster the plot will be updated.

For example:

Unidentified Flying Object Data Acquisition System -- Missio...

### MSDAU Configuration

Description: MSDAU IP x:144  
File Name: msdau-144.json  
Location: LAX  
Type: multi  
IP: 192.168.1.144 Port: 1500

#### Trigger Control levels in percent deviation from average

Trigger level for Temperature, Pressure, Humidity: 0.5  
Trigger level for Magnetometer and Accelerometer Gs: 2.0  
Trigger level for Orientation, Gyro and Accelerometer degs: 2.0  
Trigger level for Electromagnetic (Tri-Field Meter): 7.0

#### RF Spectrum Analyzer

Minimum frequency, MHz: 89.0 Maximum frequency, MHz: 108.0  
Peak detection level in dB: -30.0  
RF amplifier gain: 40.0  
For Standard SDR: -40 to 40 For UWB SDR: 0 to 102 Lowpass filter cutoff in Hz: 100.0

New Open Save Save As Close Window

The RF spectrum portion of this configuration will result in the collected RF data as shown in the example below.

MSDAU 1 RF Spectrum 01 November 2025 14:49:51PM Sweeps: 5426

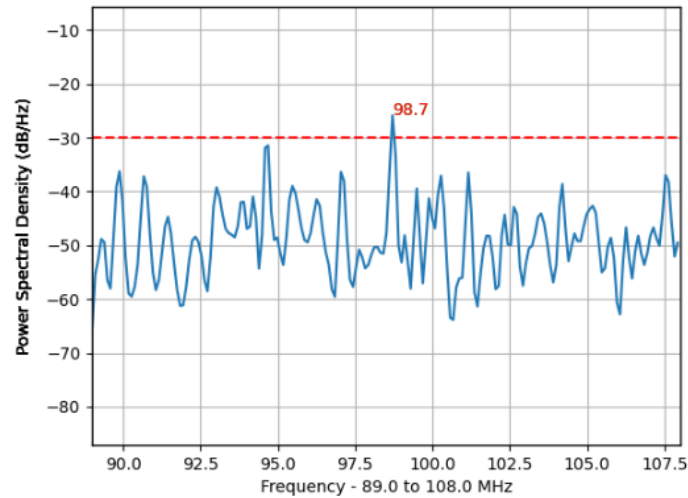

## Recording Options

The screenshot shows a window titled "Unidentified Flying Object Data Acquisition System -- Mission Control Version 3.10 ...". The main heading is "Recording Options".

Options include:

- Disable recording
- Enable recording  
Disable when MC quits
- Enable recording until manually disabled
- Allow recording only during triangulation
- Data Interval -- Period in seconds between recorded samples of MSDAU sensor and RF data  
Actual MSDAU sampling rate may be higher -- Use 0.0 for MSDAU rate  
Larger value limits size of recorded files  
3.0
- Map video
- RF Spectrum CSV
- Sensor data CSV
- Weather data CSV
- Air Traffic data CSV
- Video 1
- Video 2
- Data path: D:\UFODAS MC
- Buttons: Save, Close Window

**Disable recording** – Disables recording enabled by either of the following two selections.

**Enable recording – Disable when OTDAU quits** – Enables the following selections to control data recording if checked. Defaults to disabled when the system is started to prevent accidental recording during the typical system startup. Startup may involve testing data acquisition, parameter tuning such as MSDAU settings followed by test Runs. This setting is retained through all changes to configurations or Run/Stop until OTDAU is shut down (Quit).

**Enable recording until manually disabled** – Enables recording but does not automatically disable when OTDAU quits. Recording is automatically reenabled whenever OTDAU starts. This option may be used with the AutoStart option to automatically reenable recording when OTDAU restarts.

**Allow recording only during triangulation** – If recording is enabled, start recording only when triangulation begins, namely, when two data from two cameras results in triangulation of a target.

**Data Interval** -- Data sample write interval selection to limit data file size. Writes one sample of MSDAU data per interval – Note that the rate that the MSDAU collects the data and sends it to the MC may be higher. This period applies to all MSDAU data including RF data.

**Map** – Record the Google Map display as a continuously changing video.

**RF Spectrum** – Record the spectrum received from all configured MSDAUs

**Sensor Data** – Record data from any configured MSDAUs.

**Video 1** – Record video from the first active camera. An active camera is one associated with a configured OTDAU.

**Video 2** – Record video from the second active camera.

**Data path** – The disk drive path where the system will create a folder that will contain any video or image files collected during run time, as selected above. The folder will be created if it does not already exist.

**NOTE:** Recording will be terminated when MC is Stopped, regardless of OTDAU/MSDAU trigger status. Recording during triangulation.

**NOTE:** Trigger indications and triangulation calculations and display will occur with/without recording enabled. Recording is extended by two seconds beyond loss of tracking or triangulation for continuous recording through dropouts.

For example, with Recording Options set as shown below:

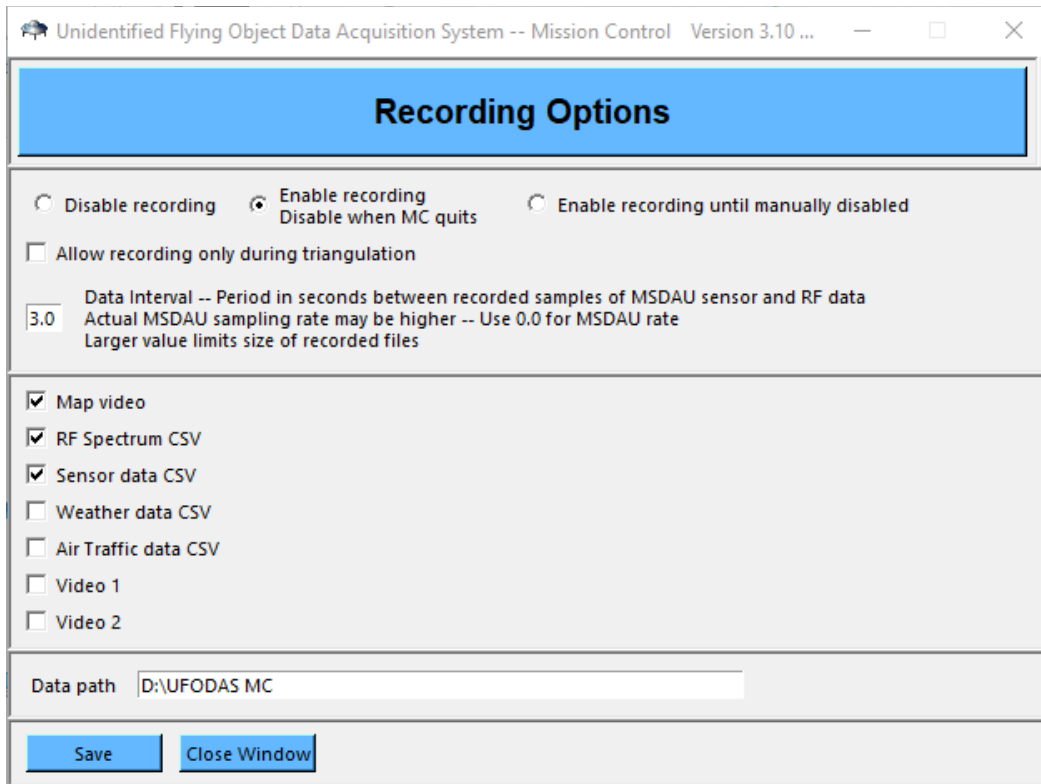

After an MSDAU trigger condition occurred, the following files will be written:

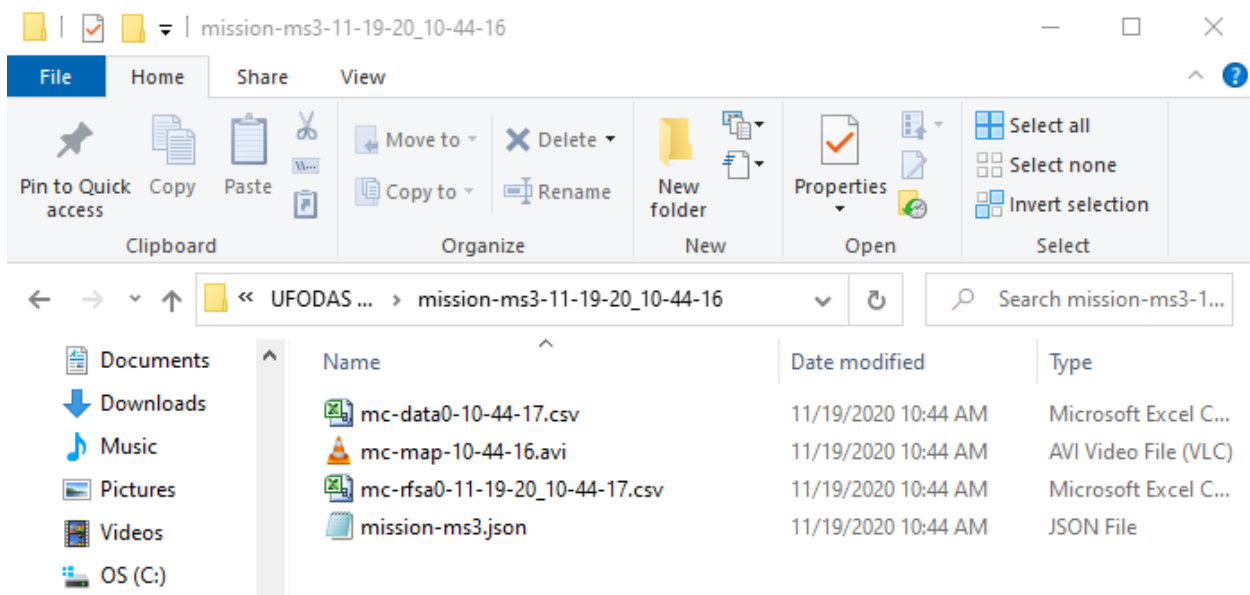

The MSDAU data CSV file contents looks like:

	A	B	C	D	E	F	G	H	I	J	K	L	M	N	O	P	Q	R	S	T	U	V	W	X
1	DAU 0	Triggered	Date	Time	Time Sour	GPS Latitu	GPS Longi	GPS Altitu	Humidity	Temperat	Pressure	Compass	Compass	Compass	Orientatic	Orientati	Orientati	Gyro yaw	Gyro pitc	Gyro roll	Accel yaw	Accel pitc	Accel roll	EM Field
2		TRUE	20-11-19	10:44:16	CPU	34.18898	-118.511	247.289	22.139	43.868	29.487	13.704	38.202	12.885	52.653	359.742	77.996	0.544	0	0.009	50.677	359.746	78.331	0.008
3		TRUE	20-11-19	10:44:17	CPU	34.18898	-118.511	247.289	22.108	43.832	29.486	11.429	42.825	12.475	50.679	359.737	79.149	0.179	0.004	0.005	48.903	359.746	79.645	0.01
4		TRUE	20-11-19	10:44:18	CPU	34.18898	-118.511	247.289	22.304	43.886	29.487	11.275	51	13.632	43.54	359.793	83.17	0.017	-0.001	-0.002	42.967	359.782	83.574	0.009
5		FALSE	20-11-19	10:44:18	CPU	34.18898	-118.511	247.289	22.465	43.832	29.487	10.46	50.342	16.568	43.147	359.751	85.471	0.046	-0.011	0.003	43.599	359.754	85.827	0.003
6		FALSE	20-11-19	10:44:19	CPU	34.18898	-118.511	247.289	22.09	43.921	29.486	10.105	49.933	16.348	44.17	359.743	87.66	-0.335	-0.001	-0.006	44.852	359.747	88.071	0.015
7		TRUE	20-11-19	10:44:19	CPU	34.18898	-118.511	247.289	21.235	43.797	29.486	13.026	37.165	16.077	45.303	359.584	87.585	-0.004	0.077	0.002	45.479	359.587	87.395	0.011
8		TRUE	20-11-19	10:44:20	CPU	34.18898	-118.511	247.289	22.009	43.85	29.486	12.861	32.91	14.146	45.478	359.576	86.952	-0.002	0.008	0.001	45.413	359.51	86.758	0.006
9		FALSE	20-11-19	10:44:20	CPU	34.18898	-118.511	247.289	22.111	43.939	29.487	10.578	28.493	17.946	46.057	359.64	85.337	-0.001	-0.002	0.001	46.672	359.655	85.179	0.005
10		FALSE	20-11-19	10:44:21	CPU	34.18898	-118.511	247.289	22.069	43.815	29.487	9.94	30.557	21.937	47.47	359.674	84.438	0	-0.002	0	48.357	359.608	84.296	0.005
11		FALSE	20-11-19	10:44:21	CPU	34.18898	-118.511	247.289	22.15	43.85	29.486	6.836	32.007	23.96	48.358	359.622	84.023	0	0.007	-0.003	49.752	359.633	83.889	0.014
12		FALSE	20-11-19	10:44:22	CPU	34.18898	-118.511	247.289	22.15	43.903	29.487	11.454	43.173	23.591	52.094	359.619	82.926	-0.001	0	0.002	52.446	359.629	82.819	0.014
13		FALSE	20-11-19	10:44:22	CPU	34.18898	-118.511	247.289	22.15	43.903	29.487	11.454	43.173	23.591	52.094	359.619	82.926	-0.001	0	0.002	52.446	359.629	82.819	0.014

The MSDAU RF spectrum CSV file (partial) looks like:

	A	B	C	D	E	F	G	H	I	J	K	L	M	N	O	P	Q
1	DAU 0 RF Spectra																
2	20-11-19 10:44:16 CPU																
3	Frequency	88	88.002	88.005	88.007	88.009	88.012	88.014	88.016	88.019	88.021	88.023	88.026	88.028	88.03	88.033	88.035
4	Power	-17.927	-18.317	-19.338	-19.126	-19.914	-18.237	-19.314	-19.103	-18.388	-18.179	-16.313	-16.65	-17.408	-16.539	-17.711	-17.76
5	20-11-19 10:44:17 CPU																
6	Frequency	88	88.002	88.005	88.007	88.009	88.012	88.014	88.016	88.019	88.021	88.023	88.026	88.028	88.03	88.033	88.035
7	Power	-17.927	-18.317	-19.338	-19.126	-19.914	-18.237	-19.314	-19.103	-18.388	-18.179	-16.313	-16.65	-17.408	-16.539	-17.711	-17.76
8	20-11-19 10:44:18 CPU																
9	Frequency	88	88.002	88.005	88.007	88.009	88.012	88.014	88.016	88.019	88.021	88.023	88.026	88.028	88.03	88.033	88.035
10	Power	-17.927	-18.317	-19.338	-19.126	-19.914	-18.237	-19.314	-19.103	-18.388	-18.179	-16.313	-16.65	-17.408	-16.539	-17.711	-17.76
11	20-11-19 10:44:19 CPU																
12	Frequency	88	88.002	88.005	88.007	88.009	88.012	88.014	88.016	88.019	88.021	88.023	88.026	88.028	88.03	88.033	88.035
13	Power	-20.068	-19.711	-19.663	-19.558	-19.677	-19.42	-19.571	-19.437	-18.615	-18.107	-18.055	-17.492	-17.986	-17.107	-17.224	-17.063

## Sharing Options

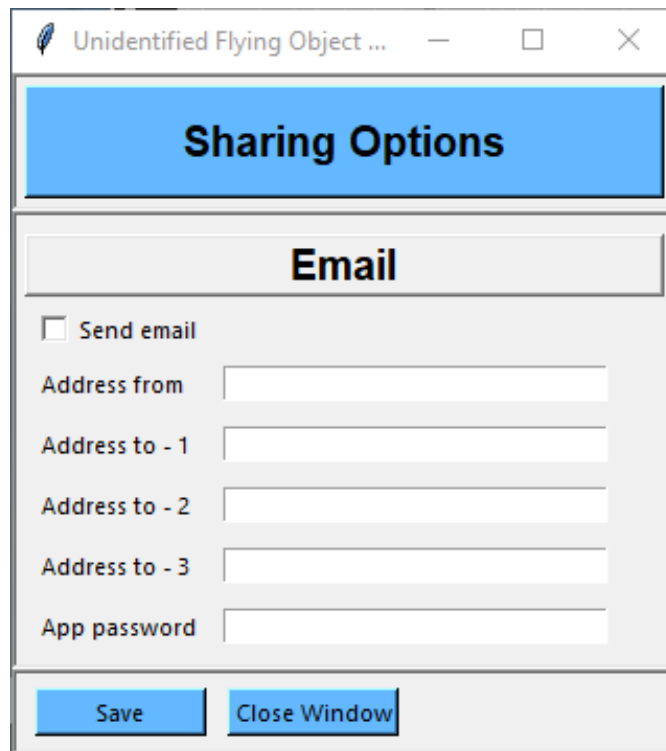

Unidentified Flying Object ...

### Sharing Options

#### Email

Send email

Address from

Address to - 1

Address to - 2

Address to - 3

App password

Save Close Window

### Email setup

Checking the **Send Email** checkbox will cause the system to send an email including all recorded video and still frame files as well as the current System configuration JSON file for reference.

**'Address from'** – Your email address such as johndoe@gmail.com.

**'Address to – 1, 2, 3'** -- Up to three email addresses that you would like the system to send emails to. A copy of the same email will be sent to each address.

**'App password'** -- The application-specific password associated with the named Gmail account. This is not the Gmail password you use for access to emails via gmail.com.

You can generate an app password by the following process:

<https://support.google.com/accounts/answer/185833?hl=en>

Start by navigating to your Google Account via the hyperlink in the above page. Follow the steps shown under Create & use app passwords. When asked to select an app, enter OTDAU and then click GENERATE. Type this 16 character, lower-case password into the Email password field and click Save.

If the Send email box is checked, an email will be sent just prior to the system has returning to the camera Home position if the following conditions are met:

- After each data collection sequence is complete and data is saved
- After a target object has been identified and tracked until lost to view

The system accepts the tracking sequence (e.g., it was long enough) and just prior to the system returning to the camera Home position.

## Setup Selections

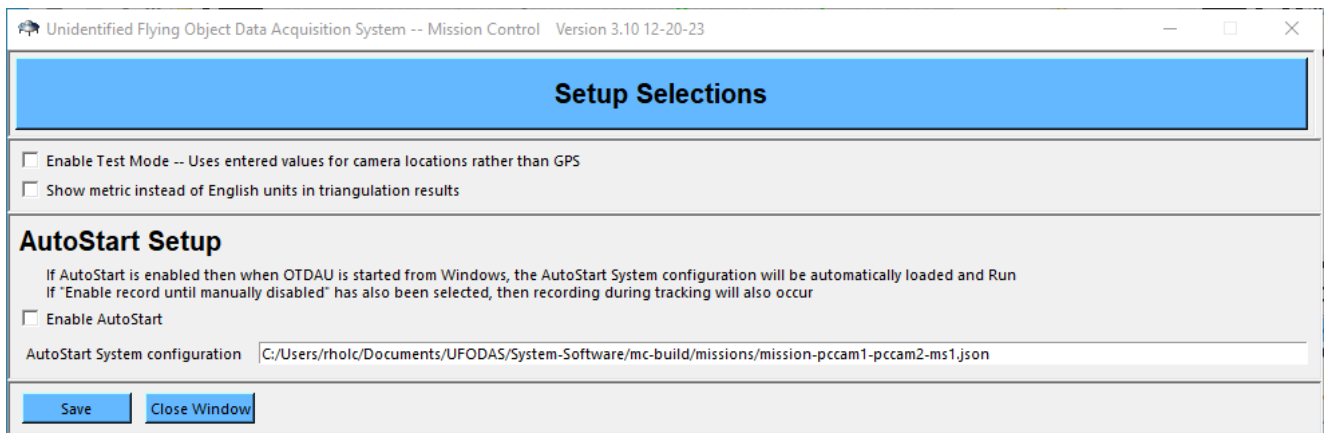

**Enable Test Mode** – Enables a mode in which the MC will triangulate data from two cameras regardless of their actual trigger condition. This allows testing of system triangulation calculations when the cameras, via their respective OTDAU software, are manually positioned to simulate common target acquisition, even though the OTDAUs have not detected motion. Manually set the location of each camera via their Sensors > OTDAU Location settings and do not enter a value for their Associated DAU to prevent override of their entered locations by MSDAU/GPS values.

**Show Metric units** – Select presentation and recording of data in metric units rather than English units.

MC can automatically Load and Run any System configuration when started from Windows. This may be useful for situations where system power may not be reliable – when power drops out and then returns, and the computer reboots, OTDAU can restart, running, with the same options enabled as when power went down.

AutoStart may also simply be used to manually startup MC in a Run mode in the least time.

If AutoStart is enabled and a System configuration is selected and saved, then when MC first starts up, that configuration is Loaded and Run. Disable AutoStart to start up normally but retain the selected System configuration. AutoStart may be used with or without the Record until disabled option to automatically start, run and record during tracking just by running OTDAU.

Use Windows Task Scheduler or another method of your choice to automatically start MC during Windows startup.

**Enable AutoStart** – Enables automatic Load and Run the next time OTDAU is started.

**AutoStart System configuration** – Clicking in this field will open a list of System configurations. Selecting one of those will populate this field with the selected configuration.

## Help

### Help > Documentation –

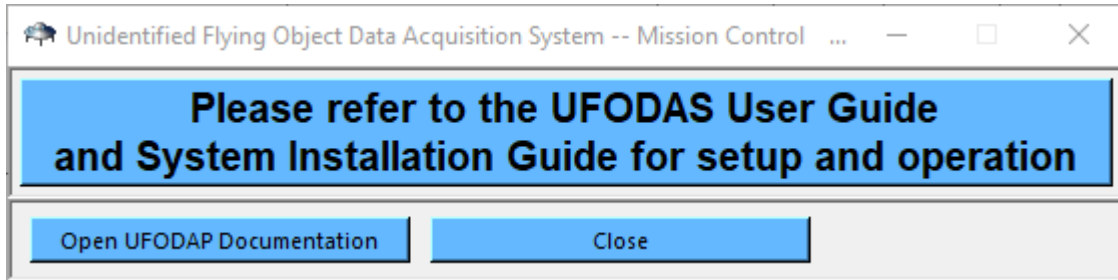

Clicking on “Open UFODAP Documentation” will open the part of ufodap.com providing various documents as pdfs in a browser window. You can then leave any document open for reference.

### Help > About –

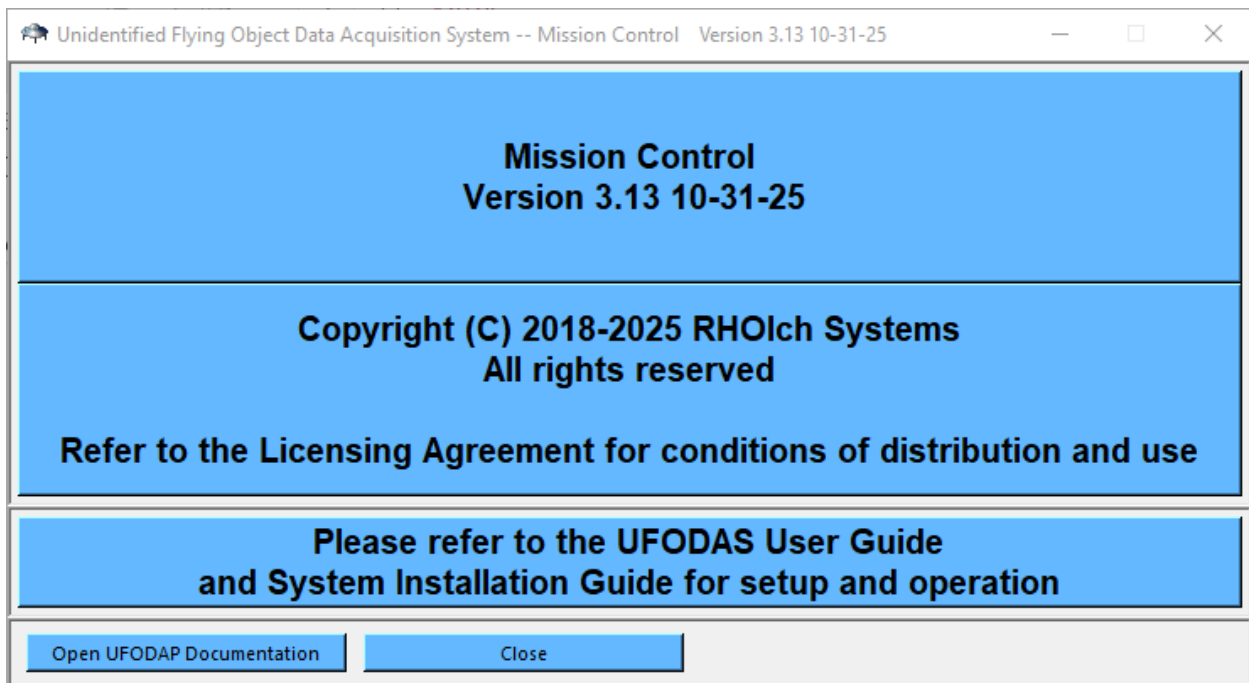

This window shows the current version of MC software. The version is also shown at the top of the main display.

## Help > Manage License –

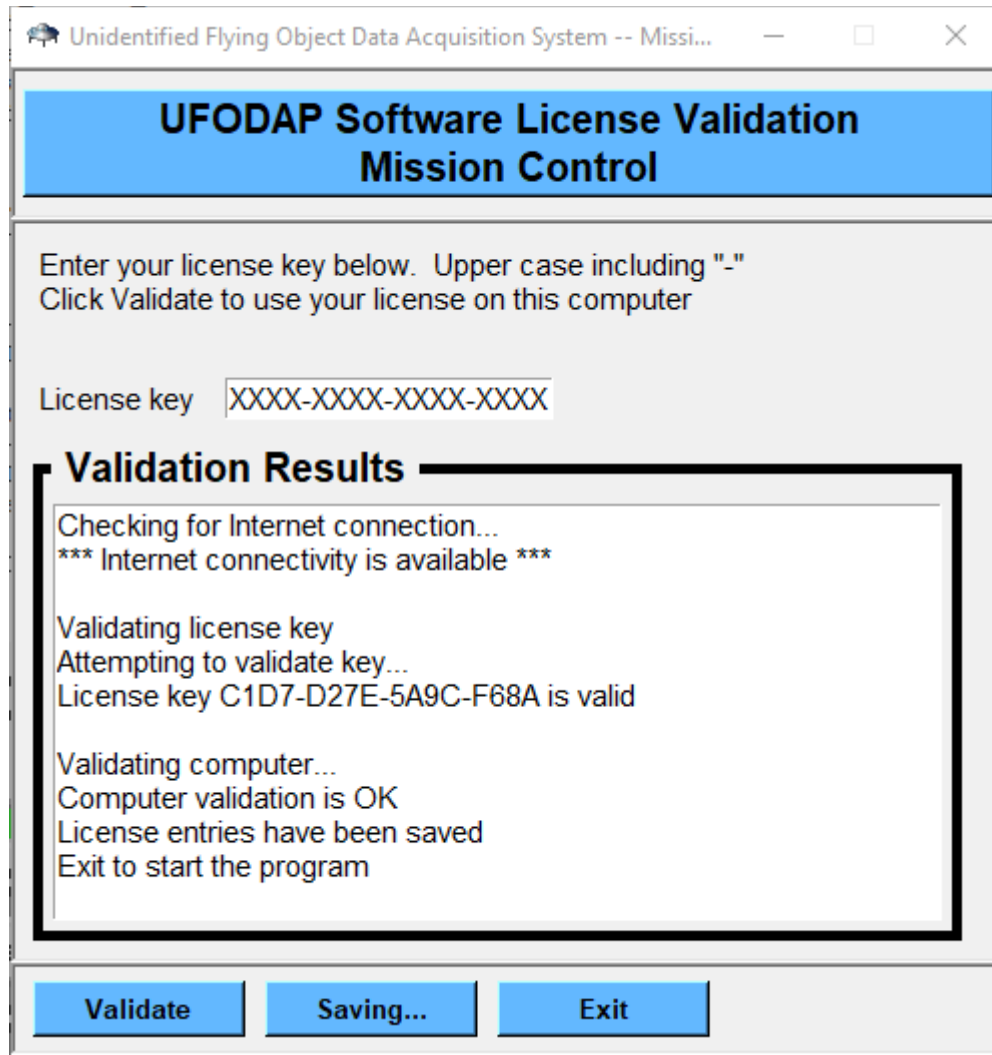

Check the validity of your license key by entering it and clicking Validate.

If the key is correct, then "License key validated" will be displayed. Clicking Exit will return to the MC software.

If the key is incorrect, it will display "Invalid key". Exiting will close the MC software. To run MC, restarting it will display the Validation screen. Correct the key and click Exit.

When validating from Manage license, wait for Exit button before returning to OTDAU. To support field operations, does not need to check for internet connectivity if a license file with key already exists. Also, verifies that the key, computer ID and a valid camera (or USB) were validated at some time. If so, then OTDAU is immediately started.

# Optical Tracking Data Acquisition Unit (OTDAU)

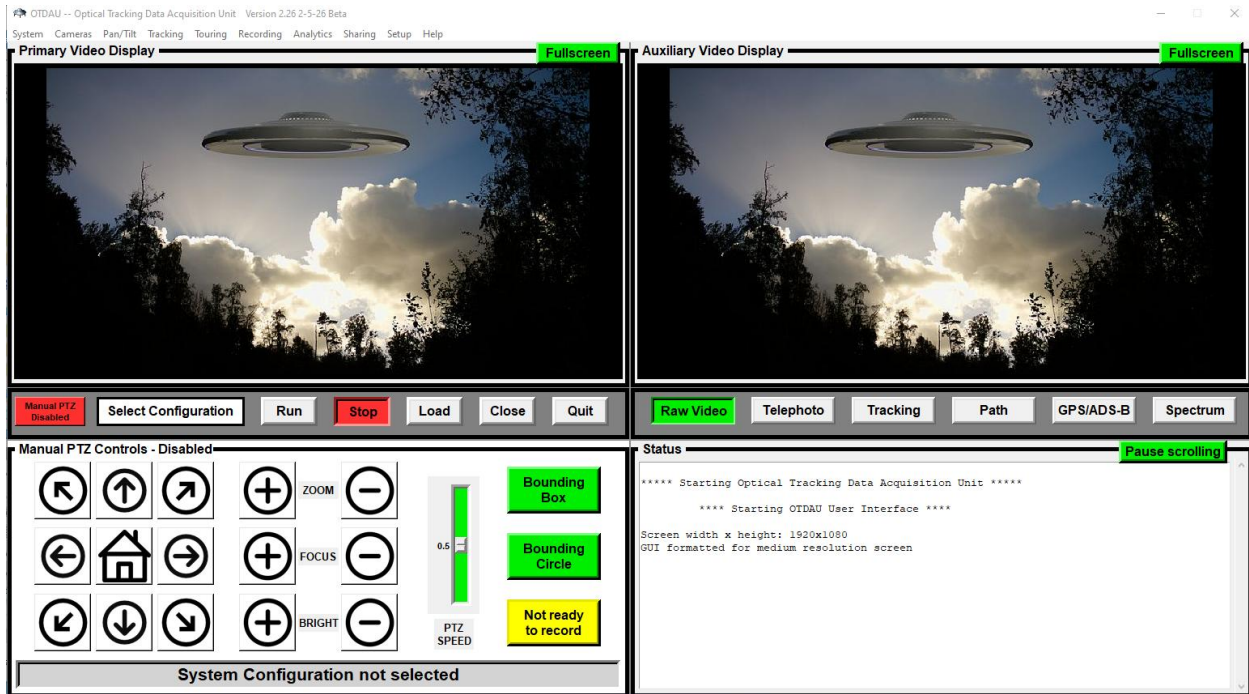

## Introduction

The UFODAS system architecture supports a variety of Data Acquisition Units (DAUs). One type of DAU performs optical acquisition, tracking and recording of objects in motion within its Field of View (FOV). This type of DAU is thus an Optical Tracking DAU or OTDAU.

An OTDAU may be set up to use one or two cameras. The system supports a wide range of supported cameras including USB webcams up to sophisticated all-weather IP cameras with pan and tilt as well as optical zoom. The software architecture is designed to adapt to most any camera or the PTDAU Pan-Tilt-Zoom (PTZ) positioner.

In dual camera applications, one camera may be a non-PTZ type that views a wide field of interest including all-sky cameras. The second camera would be a PTZ camera directed to point at the object based upon its relative location in the field of view of the wide-angle camera. The PTZ camera then independently tracks the object.

Whether using one camera or two, the processor samples frames from the wide-field camera and through some sophisticated image analysis, detects qualified moving objects. It then directs the pan-tilt head to point the telephoto camera at the object and collects images from it. The software can acquire an object of interest and smoothly track while zooming in to a moving object even with a single camera. Maintaining track while moving the camera, which causes the background to also move, was a significant part of the development effort of the OTDAU software.

## OTDAU Quick Start Guide

The OTDAU Graphical User Interface (GUI) provides typical Windows-style menus, such as File, Open to select a camera(s) and data collection process, PTZ controls for initial positioning of a camera to a field of interest, video displays and system status.

The basic process of using OTDAU includes:

1. Select a System configuration. This defines which cameras are to be used, start and stop times and other items (defined below). Initially, click System, then Open configuration. Then double-click on “test-aerobatics.json”.
2. Click Load to load the selected System configuration. **NOTE:** OTDAU remembers any System configurations successfully opened so that next time OTDAU is started or after a configuration is closed, just click Load to select a configuration from a list of prior selections. If you only opened one configuration, then clicking Load will automatically load that one.
3. Click Bounding Box and use the mouse to draw a box on the Wide display indicating the region in view that OTDAU will pay attention to moving objects.
4. Optionally select any options for Recording, Email or Analytics
5. Make any necessary changes to Tracking options.
6. Run the configuration

Clicking the Run button starts scanning for moving objects and thus, all the actions which occur if one is detected. The video sources are displayed along with embedded meta-data text overlay and a blue bounding-box. The user can select the size and location of the bounding-box to avoid initial false detection due to object proximity to foliage, for example. Also, the right-hand, multi-function Auxiliary Video display can show the telephoto camera stream with its meta-data overlay, the Raw, non-annotated stream, indications of tracking accuracy or the tracked object path.

### What you need:

- UFODAS software installed to the standard Windows Program Files (X86) folder.
- At least one camera. It may be a USB camera or an IP camera, with or without PTZ capabilities. Any combination of these cameras may also be used if the Wide camera is different from the Telephoto camera.

### Setup:

- If your laptop computer has a built-in webcam, it is USB-0.
- If you use an external USB camera, plug it directly into your PC. If you also have a built-in webcam, then the external camera will be USB-1. A second external camera would be USB-2.
- If you use an IP camera, connect its Ethernet cable to a PoE injector. Connect the injector's LAN connection to your router. No additional connection to your PC is required, if it already communicates to the internet via that same router. If the IP camera is connected to your router, then its IP address will include its local (non-forwarded) LAN address, typically 192.168.1.x. If you want to use a remote IP camera on some other router, you must use its port-forwarded IP address obtained from the owner of the router. Refer to the Installation Guide for more information on camera setup and testing.
- Click on the OTDAU UFO icon to run the OTDAU program.

### **Operation:**

- Click on System > Open configuration and double-click on a System file to select an OTDAU configuration. For example: usb0-800x600 or dahua-50230-108-80-1920x1080. The term local in the file name indicates a camera directly connected to the user's Local Area Network (LAN), that is, to his router either by cable or by WiFi. (All of the configuration file names are simply examples – you can create/rename such a file to any Windows-compatible name.) Thus, the names of such files are arbitrary, but the dot extension must be "json". Click Close Window after configuration selection.
- Click Load. The system should initialize and display the selected camera image.
- Notice the scroll of messages in the lower right panel. When it stops, the system is Ready to Run, as indicated by the Status box next to the Run button. You should also see a video display from the selected camera(s) in the left and right video panes which replace the default flying saucer images.
- The PTZ Controls are Enabled for use when the system is in Stop mode. At this time, you can move the camera (if it is PTZ-capable) to a preferred position. Use the SPEED control slider to adjust the speed of PTZ actions controlled by the

UP/DOWN/LEFT/RIGHT and WIDE/TELE buttons. This will be the position that the camera will automatically return to after a tracking run.

- Click on System > Recording and select what type of data you would like to record when there is an event. Set the Data path to a disk location you want to use to save the recordings, such as “D:\OTDAU data”. Click Save if you make any changes, then Close. (If the data location does not yet exist, then OTDAU will create it the first time recording starts.)
- Explore the other menus under System, Camera, Analysis, Sharing and Setup to see if there are other changes you would like. Note that all parameters in these various menus are saved in the System json file you opened except those under Cameras. The Cameras Wide and Tele Configuration selections refer to the cameras selected by the System file. If the camera is PTZ-capable, and motion is desired, be sure that the PTZ box in the System menu is checked.
- Press Run to start scanning for moving objects. The Status box shows the system's state, while the System Status pane provides a continuous scroll of ongoing operations. You will probably not need to pay attention to these unless you report the state of the system if a fault occurs.
- You can press Stop at any time to end frame acquisition and data analysis. Stop will return a PTZ camera to its Home position. You can press Run again to restart. For example, you may want to re-position the camera at a better Home position by pressing Stop, using the PTZ controls and then click Run.

### **Data Analysis:**

- If enabled, any data collected will be saved in a folder in the specified Data path, identified by the System folder name you entered under which it was collected and the date/time. This folder will contain all video files, individual still frames, Path jpg, log file and PTZ data files.
- Video files have an extension of .avi and are best played by the VLC Media Player. Still frame files have extensions of .jpg and may be viewed like any other photo (e.g., just double-click them). PTZ data files use the extension .csv. The json file you selected that defines the System configuration and its referenced Camera configuration files are also saved.

### **Full Screen Display:**

Both the Wide and Aux displays include a “Fullscreen” button on the top right in green. When this button is clicked, the associated video will appear on the full main PC display. The original OTDAU GUI will also be retained on whichever display it was on when the Fullscreen button was clicked. The display will return to normal if the button, now shown as “Exit Fullscreen” in red, or if ESC or F11 is pressed on the keyboard.

## Camera Options

As noted above, the UFODAS is designed to use a wide variety of cameras. The camera selection for a particular application would be based on the following criteria:

- Cost
- Need for triangulation of data from two cameras
- Size and ease of deployment
- Image resolution
- Anticipated target speed

Smaller, lower-cost cameras, such as USB “webcams” may be useful in situations where the investigator does not have access to the larger UFODAS configurations and/or can purchase the camera or already owns one. It is also the most portable. In this case, the entire installation may consist of just the user’s computer and such a camera. This system can, unattended, collect video and still frames with meta-data including time of day.

The Dahua, Lumanys and Univision PTZ cameras have the PT motion speed required for most situations, as do most of the others, but have superior imaging capabilities. This contrasts with an older Sony camera with low resolution and poor response in dark conditions (thermal noise). An Amcrest camera is very low cost (~\$100), has good image quality but lacks optical zoom. UFODAP cameras are rated for IP66 or IP67, outdoor use. Many other cameras were evaluated but did not provide features better than those in the UFODAP Shop for their cost and often presented programmability issues.

A mid-range system (the focus of the recommended initial development and test) would use a good-quality PTZ camera with 1080P resolution and at least 20x optical zoom, such as the Dahua 50230XANR. As mentioned above, this camera was selected as one of several recommended for typical UFODAS applications after extensive research and test of alternatives due to its high performance including PTZ speed and image resolution, all-weather rating, good technical support and relatively low cost. It was found that other cameras, regardless of nominal specifications, could not be used because they either did not provide an adequate PTZ software interface or did not adhere to their own specifications. UFODAP camera data sheets are available on ufodap.com. More detailed information may be obtained from the manufacturer websites:

<https://us.dahuasecurity.com/>

<https://www.luminyscorp.com/>

<https://global.uniview.com//us/>

Data sheets for all cameras offered in the UFODAP Shop are available in the Downloads section of ufodap.com.

The architecture of the UFODAS software also provides for adding new types of cameras. This feature will provide for the use of higher-end cameras that cover different portions of the spectrum such as the MWIR (3.0-5.0 um) FLIR RS6700 used with a high-speed Pan/Tilt head such as the FLIR PTU-D48 E Series.

This type of camera can provide up to 1344 x 784-pixel Medium Wave Infrared (MWIR) images using an internally cooled indium antimonide (InSb) detector with up to 10x zoom. One trade-off in using such a camera is its relatively narrow wide-angle field-of-view (FOV). The RS8300, for example, has a maximum FOV of only 8.97 degrees compared to up to 87.8 degrees of Lumanys cameras. In applications where the location of the object of interest is well known, this is not a problem. However, in our application, we need to cover as much of the sky as possible while scanning for initial object acquisition. Thus, the use of an IR camera may need to be coupled to the need for a second, wide-angle EO camera on the same pan-tilt mechanism. As mentioned previously, the UFODAS is designed to accommodate that sort of configuration by making the initial target recognition with a fixed-field, wide-angle camera such as the Dahua NK8ZBR4 and then handing off tracking to a second, PTZ camera.

Other products also provide a combination of very capable Electro-Optical (EO) and Infrared (IR) imagers on a single PTZ mechanism. For example, Infiniti Electro-Optics makes a variety of such systems, as shown below. The UFODAP PTDAU, shown below, accomplishes the same functionality as well.



Note that the greater the zoom the more difficult it is to maintain the target in the field of view. Thus, greater zoom is useful for targets that may be initially captured while moving when the camera is zoomed out but remain in a steady position when zoomed into. These target features may or may not fit the characteristics of the UFO to be captured, so the

full capabilities of some high-end cameras may rarely come into use. Nevertheless, these capabilities may have value as they are held in reserve for unknown situations that arise.

A mid-range system (the focus of the recommended initial development and test) would use a good-quality PTZ camera with 1080P resolution and at least 25x optical zoom, such as the Luminys P54-4SA25. This camera was selected as the recommended unit for typical UFODAS applications after extensive research and test of alternatives due to its high performance including PTZ speed and image resolution, all-weather rating, good technical support and relatively low cost. It was found that other cameras, regardless of nominal specifications, could not be used because they either did not provide an adequate PTZ software interface, did not adhere to their own specifications, or did not offer any performance advantage for higher cost. An alternative, the Uniview IPC6424SR-X25-VF, has very similar specifications but trades off optical sensitivity for a somewhat lower cost.

## System Configuration and Operation

OTDAU configuration for operation is implemented by creating or using existing fill-in-the-blanks forms. The forms are accessed by clicking on one of the following tabs at the top of the OTDAU main window, shown below:

- System
- Cameras
- Pan/Tilt
- Tracking
- Touring
- Recording
- Analytics → Object Identification, Spectral Analysis
- Sharing → Send Email, Upload Data
- Setup → Display, PTZ Control and Tracking, AutoStart
- Help → About, Manage License

An OTDAU is configured for operation for a particular application by setting several parameters via the System configuration window. This window is accessed by clicking on the System tab at the top of the main window.

The Status display in the lower right of the main window provides a running list of messages related to what OTDAU is currently doing and its status. Prior messages no longer in the window may be viewed when OTDAU is Stopped. Messages may be scrolled through using your mouse wheel or the slider on the right side of the Status display.

## Status

```
Validating camera...
IP: 192.168.1.108 Port: 80 User: admin Password: dahuaN51
Connected to ONVIF camera
Get device information ---
ONVIF camera hostname: Dahua_N51BD22
--- Camera information ---
Mfgr: Dahua
Model: N51BD22
S/N: 5D04D26PAG23DEB
Hardware ID: 1.00
Local Time: 10:20:32
Write the license key to a text fileExiting license validation
```

Typical uses of this information would be to see values of system variables to tune tracking or error messages to share with the system developer to solve problems.

**NOTE:** System and Camera parameters are re-read whenever Run is started allowing their user-updated values to be used without closing and reopening the configuration.

## System Configuration

OTDAU -- Optical Tracking Data Acquisition Unit Version 2.23 12-10-23

### System Configuration

System Description:

Start time:  Stop time:

Wide-Angle Camera:

Telephoto Camera:

Pan/Tilt Unit:

Bound X1:  Bound X2:

Bound Y1:  Bound Y2:

Maximum zoom:

Operator Name:

Enable Pan/Tilt:  Enable Zoom:  Enable Sound:

#### OTDAU - Mission Control communication address selection

Computer IP address  
127.0.0.1 if OTDAU running on same computer as MC  Computer port (49152 to 65535)   
else, use static IP of OTDAU computer

After opening the System tab in the main window, click the Open button. A file selection window will open as shown below.

**NOTE:** All data entry fields in OTDAU menus provide a cut/copy/paste option – Left click on any field in OTDAU or in Windows, move the mouse to highlight the desired text and then release the button. Then right click on any field and select paste to place the text into the field. Similarly, you can cut, copy and paste between any OTDAU fields and any Windows text that is clipboard compatible.

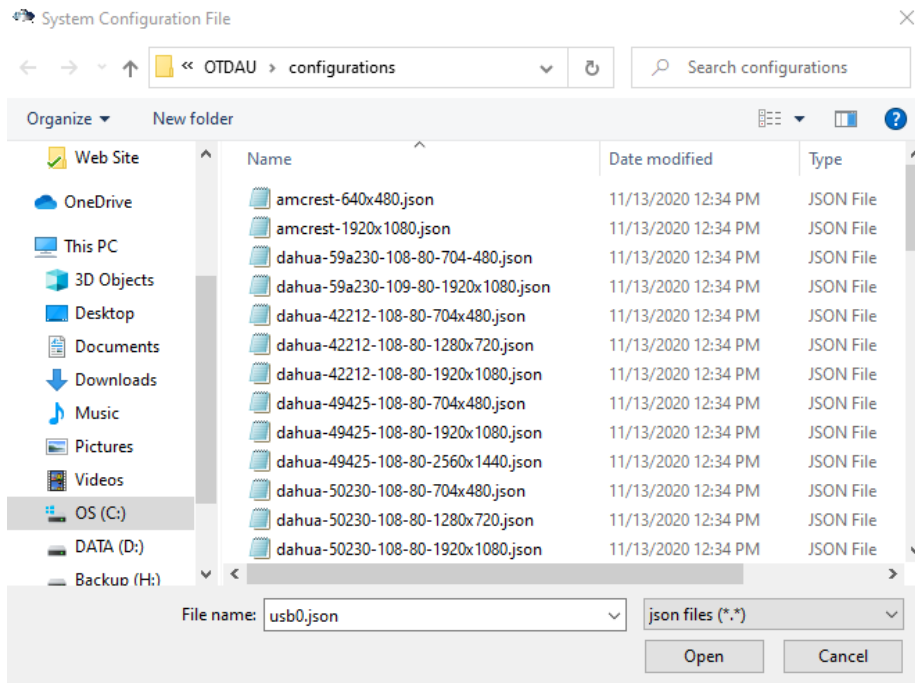

This window shows all the available system configurations. To select one, double click it or click it once and then click on Open or your selection. Note that local-usb0 is the default selection, so simply clicking Open will select the configuration that uses the USB0 device for both Wide and Telephoto camera.

A different configuration may be selected by clicking Close File, then Open and select a different configuration.

It is often convenient to create a new configuration by opening an existing one, modifying it, and then clicking on Save As. The same file list will appear but the file name, at the bottom will be highlighted and contain just “.json”. Add the rest of the desired name before the “.”, for example, “home-sony-1500.json”.

After selecting a system configuration, all its parameters are available for inspection or modification via the System, Cameras, Tracking, Recording, Sharing and Setup menus. Cameras selected for the Wide-Angle and Telephoto devices are shown in the Configuration menu. The unique aspects of a camera type are shown in the Cameras menu although camera specific parameters are stored in the cameras folder and modified via the Cameras menu.

To preserve user-modified or created configurations between new OTDAU revisions, the System, Camera and PT configuration files are now located in C:\OTDAU. After each installation, these files are copied/merged into the configurations, cameras and

positioners folders in C:\OTDAU, updating any with the same name and retaining any with a name not provided in the new Installation. **Thus, users do not need to rename or save custom configurations between new software releases.**

System Configuration form entries are:

**System Description** -- User-provided description of the configuration

**Operator Name** -- This entry should be the name of the user or other information that would clearly identify the user to others who may want to share a camera. This name will be inserted onto the Wide-Angle camera On Screen Display, replacing the text "Available", when the configuration is Run thereby allowing other potential users of that camera to know who is currently using it.

**Start time** – The time in 24-hour format at which the system will start to run if enabled to Run. Start time and Stop time are particularly useful when, for example, the sensor of the camera used is such that the image will start to pixelate under low-light conditions causing false motion triggering. Another typical use is to avoid capturing bird movements at the beginning and end of the day.

**Stop time** – The time in 24-hour format at which the system will stop running. It will automatically restart at the next Start time.

**Wide-Angle Camera** – Camera configuration selected to be the wide-angle camera.

**Telephoto Camera** -- Camera configuration selected to be the telephoto camera. Required but may be the same as the Wide-Angle Camera. If the selected camera is PTZ-capable, then it may be used with some type of Wide camera in the Handoff mode.

**Pan/Tilt unit** – Selected configuration of a Pan/Tilt unit. A PTU is a device providing a motorized mount with pan and tilt motion, for any type of load such as a video camera, DSLR camera or radar antenna. Click on this field to open a folder of available PTU device drivers. **If you are not using a Pan/Tilt unit, then leave this field blank.**

**Crop X1** -- Pixel number of the left side of the bounding box. Numbering in the x direction is from 0 to the camera's horizontal resolution, left to right. All four crop values are automatically filled in when using the Bounding Box feature. For a circular bounding circle, this is the x, y center of the circle.

**Crop X2** -- Pixel number of the right side of the bounding box

**Crop y1** -- Pixel number of the top of the bounding box. Numbering in the y direction is from 0 to the camera's vertical resolution, top to bottom. For a circular bounding circle, this is radius of the circle.

**Crop Y2** -- Pixel number of the bottom of the bounding box. This is always 0 for a circular bound.

**Maximum zoom** -- Maximum optical zoom allowed for the tracking session. It should be less than or equal to the maximum the camera is capable of.

**Enable Pan/Tilt** -- Enable pan and tilt operations for cameras so equipped. Enable Pan/Tilt is forced OFF when the configuration is saved if both referenced cameras do not have PT capabilities.

**Enable Zoom** -- Enable zoom for cameras so equipped.

**Enable Sound'** -- Enable bell sound when a potential target motion is recognized and a different system sound when it is qualified and acquired.

#### **For OTDAU to/from Mission Control communication:**

**Computer IP Address** – The IP address of the computer running the instance of OTDAU for a particular camera(s). If the computer is the same one that will be running Mission Control (MC) software, then this address should be 127.0.0.1. If the OTDAU computer is different, then this address should be a static address assigned to that computer or the port-forwarded WAN address of the computer if it is remote from the LAN running MC.

**Port** -- A unique port number assigned by the user to distinguish the computer from other devices on the LAN, such as port-forwarded cameras. The value should be in the range 49152 to 65535. This port should be different for each instance of OTDAU on the computer – For example: 51000, 52000, 53000.

#### **Control buttons**

**Open configuration** – Opens a window into the System configuration file folder. Select a configuration by either double clicking on an entry or clicking one once and then click on Open. The selected configuration must be Loaded prior to use after Opening it.

Note that the Load button may be used before or after the System Configuration window is closed by the Close Window button. See the Load button, below.

**Save** – Saves the current settings as part of the currently loaded System configuration.

**Save As** – Opens a window into the System configuration file folder. Saves the current settings as the System configuration but with a new name selected in this window. It is very useful to Open an existing configuration, modify its values, and then Save As with a new name to create a new configuration.

**Close File** – Terminates use of the last selected configuration. The camera views on the Wide-Angle and Auxiliary displays will return to the default image. If the system is in Run mode, it must be Stopped before Close File is selected.

**Close window** – Closes the System Configuration window. If the window is closed before any changes to settings are Saved, then those changes are lost.

**Open a video file for test** – A special type of open for configuration files which operates the same as opening a pre-configured test file (such as test-jet-cloud) except the user can select any avi file, anywhere on the computer, for the test. You may navigate to any folder on your system and then select any avi file in that folder. When opened, the first frame of that file will display. You can then click Run to emulate tracking of that pre-recorded file instead of using a camera. This is very helpful to analyze existing files and to adjust tracking parameters for similar future recordings using a live camera.

**TIP:** To optimize Tracking settings for a particular type of target and environment:

1. Set up the camera to point in the desired direction at a typical time/environment
2. Turn off any PTZ settings, using the camera as a fixed lens unit
3. Set recording options including Tele video without text
4. Click Ready to Record to start/stop manual recording when a representative object, such as an aircraft moves through the image. Click it again to stop the recording when sufficient target motion has occurred.
5. Load the resulting file using the above test option
6. You can now play the test video as many times as needed while adjusting various Tracking options

A System configuration may be selected in two ways:

- Click on the System tab and then Open to see all available configurations. After selecting a System Configuration, click on the Load button located below the Wide-Angle Video Display area.
- Click on the Load button without using System. This will bring up a shortcut list of any configurations that have been loaded using the System menu previously. If no configuration has ever been loaded, then you will be prompted to select one. If only one such configuration had previously been used, then that configuration is immediately loaded.

The status box on the left, also below that display area will indicate load progress (“Initializing video...”) and, when the load has been completed, it will display “Ready to Run”. When the system is Running, “Scanning” is displayed.



When a PTZ (or Zoom-only) camera is loaded, and **“Enable Pan/Tilt” or “Enable Zoom” options are set in its System configuration**, then the Manual control indicator on the left will turn green and show the initial camera that the PTZ control will affect. Clicking on this button will change the affected camera from Wide to Aux if that camera is PTZ capable. The button will again turn red during Run. **Being able to select which camera the Manual controls apply to make it easier to set up camera directions when more than one PTZ camera is in use.** All combinations of fixed cameras, PTZ cameras and a Pan/Tilt head are supported. Cameras such as the Dahua N65CL5Z that have a motorized zoom function but not Pan/Tilt are also supported.

The Close button closes the currently selected System configuration. Click it prior to using the Load button or the System menu to select a new configuration.

The Load button is used in two ways –

- To initialize a new configuration after it has been selected via the System menu.
- To select a new configuration immediately after starting OTDAU or after Closing the last configuration. OTDAU provides a list of past configurations to choose from. If only one configuration was ever selected, then clicking Load immediately loads that configuration.

The Wide-angle display at the top left of the main window displays the video stream from the selected Wide camera.

The Auxiliary Video Display, at the top right of the main window, will display a still frame or motion video depending on which of four buttons are clicked:

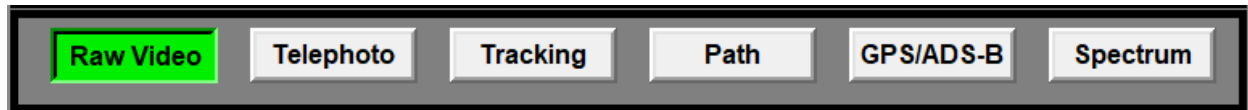

- Raw Video -- Default selection that displays the Wide-Angle camera video stream without any meta-data overlay.
- Telephoto -- Video from the configured Telephoto camera or from the Wide-Angle camera if the Telephoto camera is the same as the Wide-Angle camera. This display will include an overlay of meta-data including camera type and date and time on the bottom as well as camera position, field size and PTZ motion indicators if the camera was defined to be PTZ-capable. Displays a digitally zoomed image of the tracked object if the Wide camera is not PTZ. The level of zoom may be set in then Setup > Display menu and its value is shown on the bottom left of the Aux display.
- Tracking -- Displays video from the tracking process to aid in tracking-related parameter settings. If Feature Tracking is not enabled, then this display shows a black and white representation of frame-to-frame differences. If Feature Tracking is enabled, then this display shows the Raw video with the tracked object surrounded by a green box. This display is helpful to verify what the system is tracking and if it loses track.
- Path -- Displays an accumulation of lines indicating each time a target was recognized by the tracker during run-time. Particularly when the Wide-Angle camera is not PTZ, this is a convenient method to determine the track or motion profile of a tracked target. "Real" UAPs sometimes travel in a path with sharp angular discontinuities, unlike aircraft. This feature helps identify such targets.

The Path display includes a number at the starting point of the path that corresponds to the file number of that path. If the Auxiliary Video Option is "Path of target hits" then these numbers and the paths are randomly color-coded. If recording is enabled the path numbers and path color also correspond to the folder number of each recorded tracking event. If Recording options do not include Paths, then the path display shows each path in green.

Track path analysis – After each tracking sequence has finished, the path of the tracked target is analyzed for non-linear changes (divergence from a straight path). The point(s) of divergence is displayed and saved as a red circle on the track path.

See the Path Capture, Display and Recording section below for more details.

- GPS/ADS-B – Initiates the GPS and ADS-B status and data display. Used in conjunction with the Setup > RTL-SDR Gain Configuration window.
- Spectrum – Displays a real-time optical spectrum if the Wide camera is equipped with an appropriate grating. **(HARDWARE TO SUPPORT THIS OPTION IS IN DEVELOPMENT).**

**NOTE:** All Wide and Tele images now include the UFODAP logo in the lower right corner. The size of the logo is scaled to the resolution of the camera.

The complete main window, with Raw Video selected, will now appear as follows:

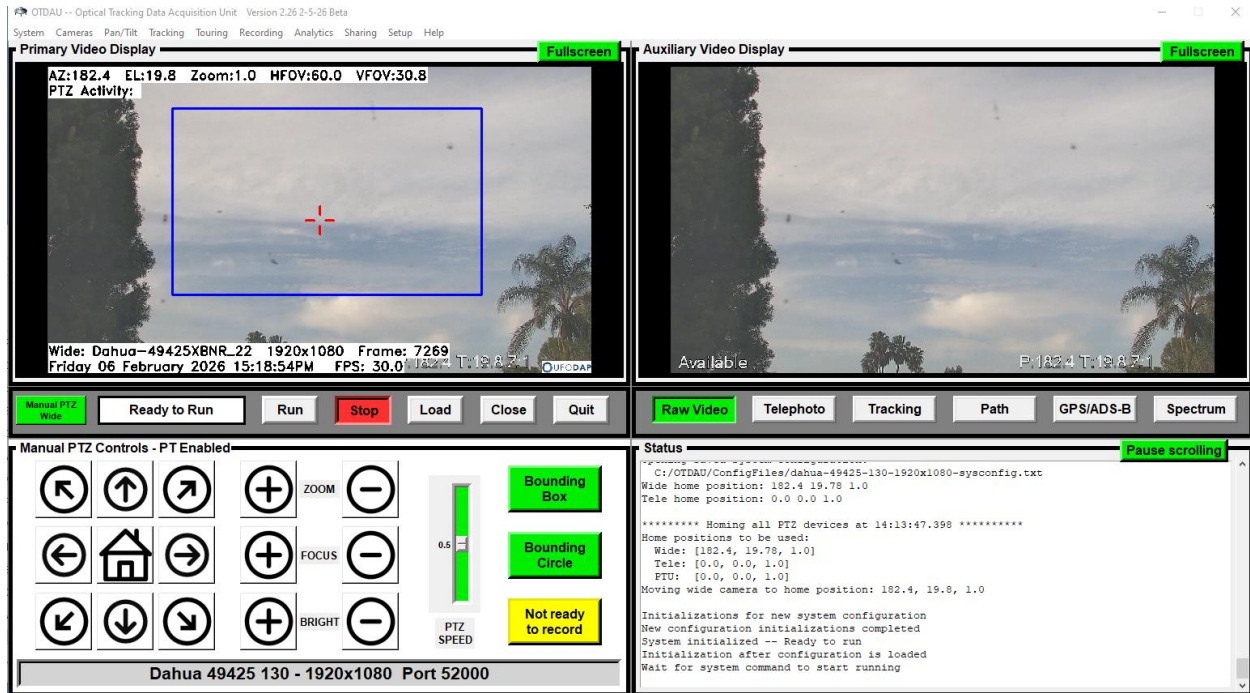

The scrolling text in the Status window, on the lower right, provides an indication of what the system is always doing. It may be used to confirm what files and cameras are in use, error conditions and other operational status. Status messages that have scrolled out of view can be viewed by moving the slider on the right or clicking into the Status window and using your mouse scroll wheel.

Clicking the Pause scrolling button in the Status display will result in no new status messages appearing. Clicking Pause again will display the last 100 messages accumulated while Pause was in effect and status messages appear normally. This feature is particularly useful to make it easier to review status while OTDAU is in Run mode with new messages causing messages of interest to scroll away.

**Note** that manual pan and tilt adjustments are only operational if the System Configuration Enable Pan/Tilt box is checked. Likewise, Zoom adjustments are only available if the Enable Zoom button is checked. The Focus and Brightness controls will not function for cameras that do not support ONVIF control of those properties.

While tracking using a fixed camera, the AZ and EL values are emulated in software. These angles are computed for useful representation when displayed by Mission Control: AZ ranges from  $(360 - \frac{1}{2} \text{ horizontal FOV})$  to  $(\frac{1}{2} \text{ horizontal FOV})$ . EL ranges from vertical FOV at the top to 0.0 at the bottom. This is as if the camera was a PTZ type initially pointed North and  $\frac{1}{2}$  vertical FOV above the horizon.

At this point, if the Wide or Telephoto camera is a PTZ unit, then the pan/tilt/zoom controls in the PTZ Controls area are enabled. The PTZ Controls, on the lower left of the main screen, are shown below.

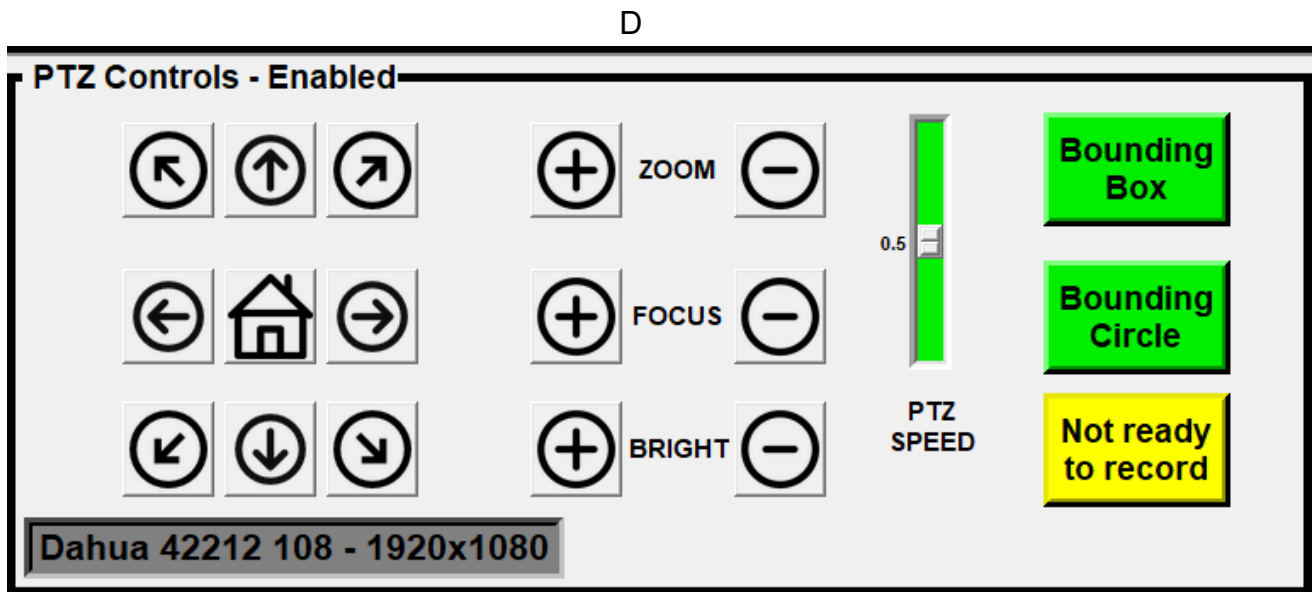

The label next to "PTZ Controls" indicates whether these controls are ready for use or not as Enabled or Disabled.

## Gamepad controls

A USB Gamepad, as shown below, may be used as another method to control all Manual PTZ functions, in parallel with mouse clicks.



The Gamepad is enabled if it is plugged in to any USB port before a System configuration is loaded.

This function has been tested only with a Logitech Dual Action control P/N 863247-0010. If a gamepad is plugged in and recognized then its type is displayed next to the “PTZ Controls” label, as shown below:

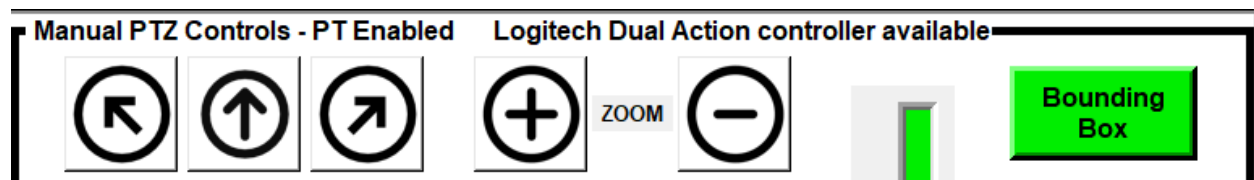

Left joystick (Axis 0 and 1) controls up/down, left/right motion with speed proportional to amount of stick movement. PTZ Speed returns to 5 when the stick is centered.

Right joystick (Axis 1 and 2) up/down controls Zoom in/out.

Buttons 0 and 2 control Focus + and -.

Buttons 3 and 1 control Brightness + and -.

Buttons 6 and 7 can be used to Run and Stop.

**Button numbers imprinted on the buttons of your device may differ from those shown above.**

Gamepad controls and the GUI buttons activated by the mouse are simultaneously available.

---

## Path Capture, Display and Recording

OTDAU can capture the path of targets through the scene to determine if the target displays the type of anomalous behavior that may indicate a UAP vs an aircraft, meteor or other natural phenomena.

When Path is selected for the Aux display, every time tracking of a target begins, its path through the field of view is shown as a series of line segments. The segments are shown in random colors if Path of target detections are selected for recording. Otherwise, paths are shown in green.

A path number is shown at the beginning of the path line to indicate the starting location when the target was first detected. One frame of the detected object is shown for reference.

An Auxiliary Video option allows automatic deletion of the folder and all related files when the target track was linear. The folder is deleted at the end of the related tracking sequence. If no nonlinear tracks are found during a Run, then there will be no Group folder remaining after the Run.

Selecting “Path of target detections” as the Aux recording option will record a real-time video of the path being captured along with other video files.

When recording, a composite of all tracked paths is included in the Group folder as a file with the format: “otdau-path-xx-xx-xx.jpg” where xx is the recording date.

These functions make it easier to automatically find UAP due to their characteristic nonlinear motion. Even if a path recording is retained, its path line is still included in the composite path image jpg file in the Group folder. Note that even fast-moving targets will result in recorded paths – each path line is composed of line segments spanning detection frames. So even if a detection is not made in every frame, there will still be a series of line segments between detection points

**NOTE:** Path tracking is intended for use with cameras using fixed optics or PTZ cameras with Pan/Tilt disabled. The motion of the camera while tracking will create a false path display. **Path functions and saving of jpg composite images will not occur if the camera is PTZ capable and P/T is enabled.** Paths are not meaningful when the target and the camera can move.

The sample Auxiliary Video Display shows a series of paths captured during one Run in daytime conditions. The paths labeled 4 and 6 are from aircraft following a common flight path. Other, lower numbered paths are not visible beneath these paths. Paths 5

and 7 are designated for short distances. 7 was short due to the aircraft exiting the bounding box just after initial detection. Path 8 is due to a bird.

Non-linearities are detected using a low-pass filter on the line. If a path includes a section(s) that does not follow a sufficiently straight line, then the inflection point(s) are marked by a red circle. One of these occurred at the end of path 6 due to just enough fluctuation in the detection area to cause the detection of a non-linearity.

The file names of recorded non-linear paths are annotated as such with the text “NLP” (Non Linear Path) when each recording (tracking event) is over.

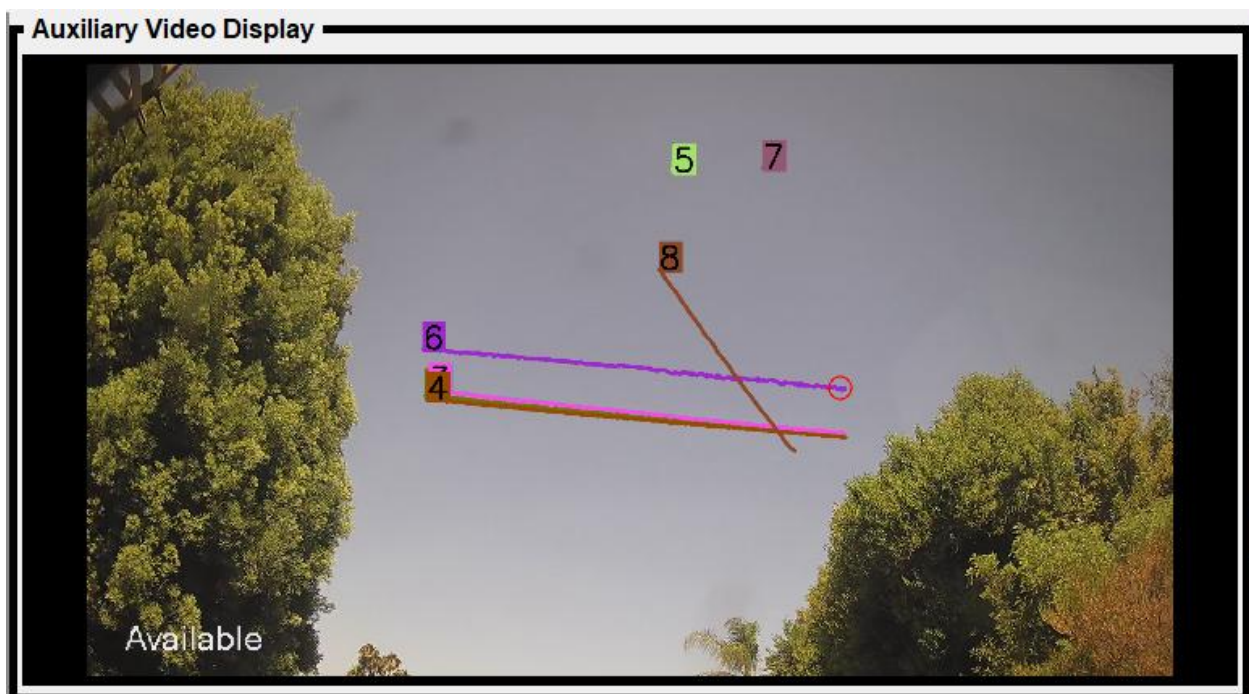

A thumbnail view of the tracked object is provided in the upper right corner of the Display.

An alternative view of target paths as a series of thumbnail photos of the target may be selected in Setup > Display options. If the option “For Path display, show path as sequence of thumbnails instead of a line”. The path number corresponding to the file number is above the starting photo and a red circle indicates any inflection point. The path will be depicted as shown below for the “test-aerobatic” configuration as an example:



**Note:** Individual paths are recorded if selected in the same subfolder as wide video files. Boxes surrounding thumbnails are the same color as the folder index for ease of identification in the jpg composite of all paths. The composite is written to the group folder along with the log and json files. The size of each thumbnail and the spacing between them is scaled to the size of the image in the thumbnail. Continuous green line paths are available when selected in Setup > Display.

---

## Automatic camera homing functions

OTDAU detects the home or initial position of a pan/tilt/zoom camera and saves it in the associated configuration whenever a System configuration starts to Run. While during the run the system is reset, e.g., due to a timeout or clutter, the camera is returned to the last set home position.

OTDAU also moves a camera(s) that are part of a configuration to its home position as soon as that configuration has been Loaded. It does this so that the user can set up camera pan/tilt/zoom values for a particular situation, as reflected in the System configuration and the camera(s) automatically return to that position.

If a configuration had never been loaded such that no home position exists, OTDAU would not move the camera(s). The user may then manually move a camera to the desired starting position. When the configuration is then Run, an initial home position is saved.

When a configuration is Loaded, a PTZ camera will move to the last position it was in when Run was initiated.

## Positioning a PTZ camera

The PTZ Controls, when Enabled, are used to move the camera into the Home or initial position, ready to begin scanning for moving targets. This is accomplished via the LEFT, RIGHT, UP, DOWN, ZOOM WIDE and ZOOM TELE buttons or gamepad if available. Moving the PTZ SPEED slider up or down will set the relative speed of any of those controls. The last position of a PTZ camera prior to starting Run will be the position the camera returns to at the end of each tracking process.

The Focus control will continuously adjust camera focus in or out while + or – is held on with the left mouse button. Releasing the mouse button after using the + or – controls stop changes to focus which eliminated focus drift after each selection.

The Brightness control incrementally adjusts camera image brightness up or down when + or – is repeatedly clicked.

Manual PTZ button to select which of the Wide, Tele or Pan/Tilt devices will be controlled by the PTZ direction, Zoom, Focus and Brightness controls. This makes it easier to set up camera directions when more than one PTZ camera is in use. All combinations of fixed cameras, PTZ cameras and a Pan/Tilt head are supported.

Manual controls are disabled when:

- Pan/Tilt and Zoom are not enabled in the System configuration
- PTZ capable is not enabled in the Camera configuration
- The system is in Run mode

For example, PTZ functions are disabled as shown in the fragment of displays, below:

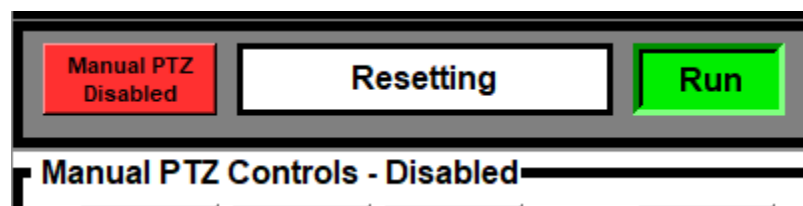

---

## Setting a bounding area

OTDAU allows the user to select the area of the Wide camera view that the system will scan for motion, ignoring the area outside of this bounding box. This is valuable to avoid triggering tracking on moving parts of the background, such as foliage. The Wide-Angle Video Display shows the bounding box in blue when the system is not running and in red when it is.

Start by clicking on either the Bounding Box or the Bounding Circle buttons. Either type will work for any camera or test video. The circle is particularly useful with panoramic, All-Sky Cameras that have a circular optical view.

To set a bounding box:

- With a System configuration loaded, click the green Bounding Box button. The button will change color to yellow. Hover the mouse over the Wide-Angle Video Display window. You can define up to 10 boxes to more precisely background clutter in view to be excluded from target detection. To define a box, hover the mouse over any corner, hold down the left mouse button and move the mouse to define a rectangular area. Multiple boxes may overlap. Click on an existing box/region to delete it. You can redraw the box, starting at any corner, as many times as needed by deleting and redrawing. A second click on the Bounding button saves the definition of bounding regions with the System configuration and eliminates any overlapping lines so that bounding regions that are not simple rectangles may be defined. This process is compatible with prior System configurations with a single rectangular region.

To set a bounding circle:

- With a System configuration loaded, click the green Bounding Circle button. Move the mouse to point to where you want to place the center of the circle. Hold the left mouse button down and move the mouse to define the size of the circle. Release the button to set the circular bounding box. Similar to bounding boxes, you can define up to 10 bounding circles which may or not overlap. A second click on the Bounding button saves the definition of bounding regions with the System configuration and eliminates any overlapping lines so that bounding regions that are not simple rectangles may be defined. This process is compatible with prior System configurations with a single circular region.
- **Note:** When operating OTDAU without Pan/Tilt enabled, a target will only be tracked when it is within the bounding box. When using a PTZ camera with Pan/Tilt enabled, a target object will be tracked for as long as it remains in view.

Some examples of complex bounding areas:

Define three boxes --

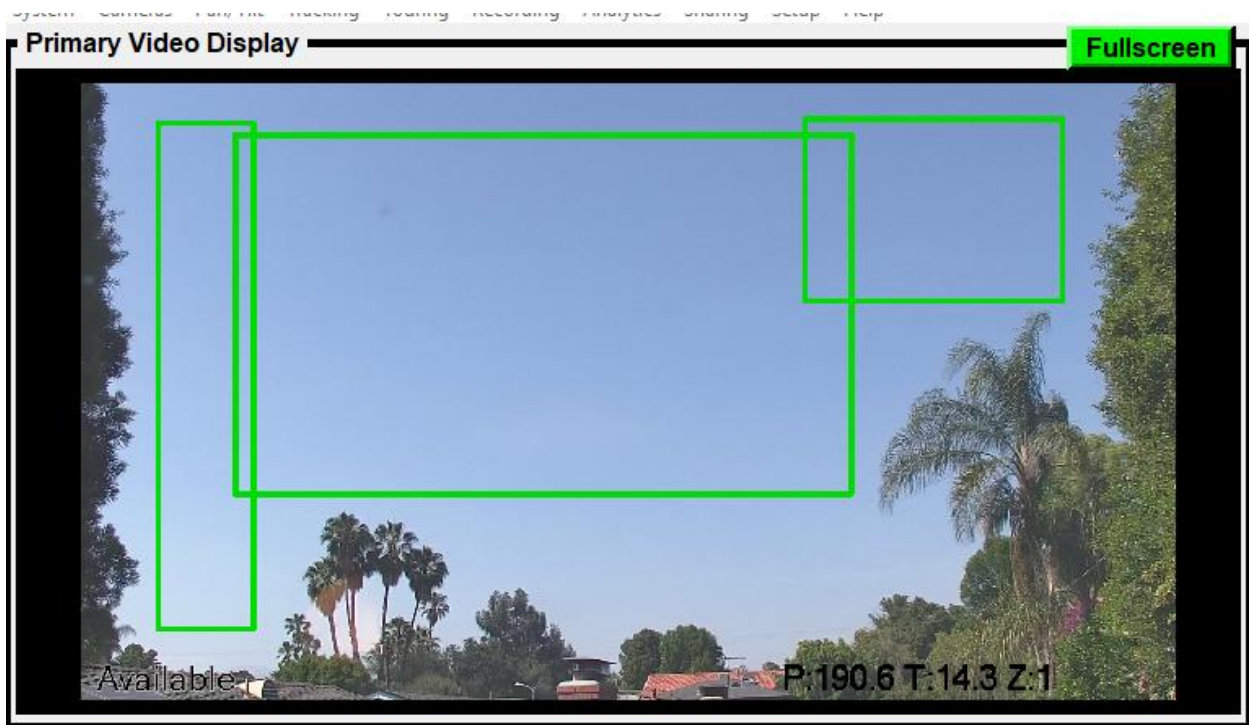

After saving them --

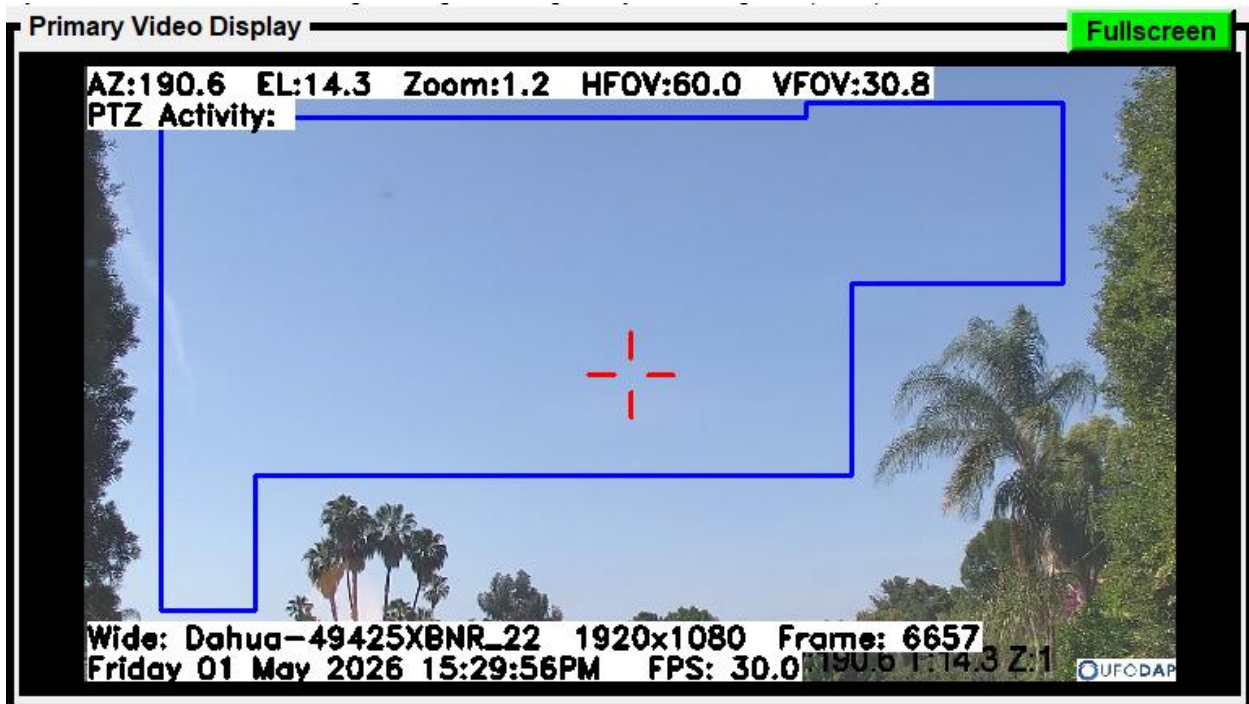

Define three circles –

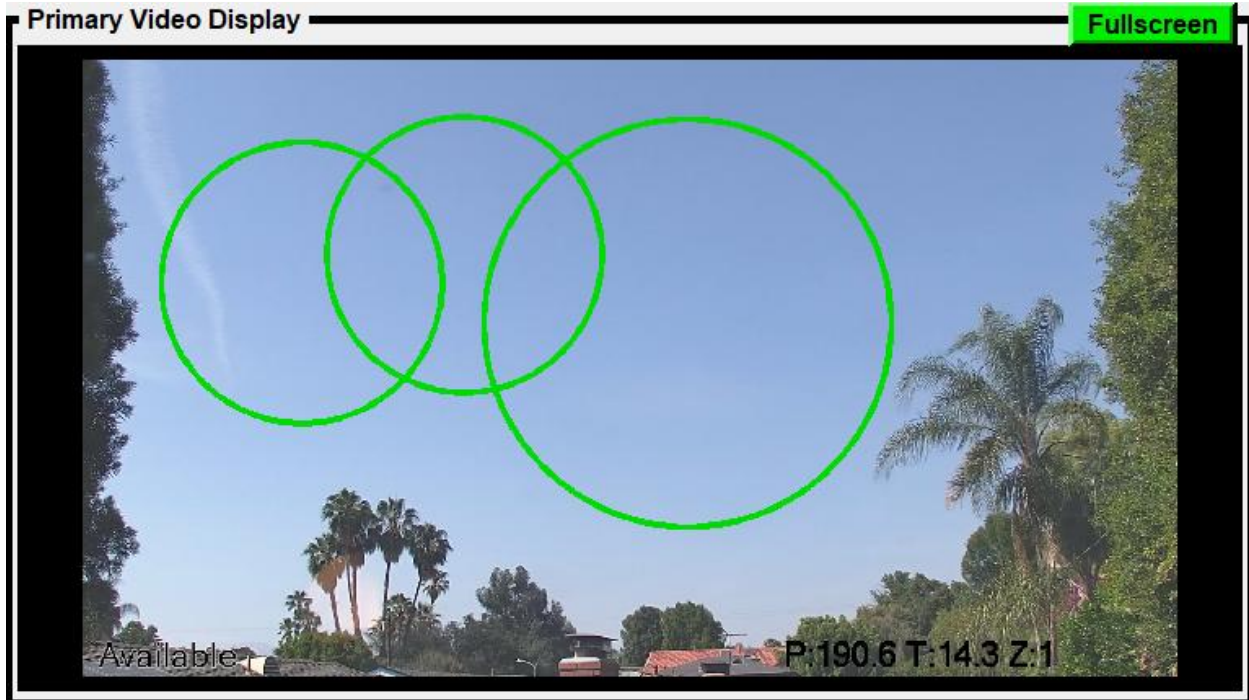

After saving them --

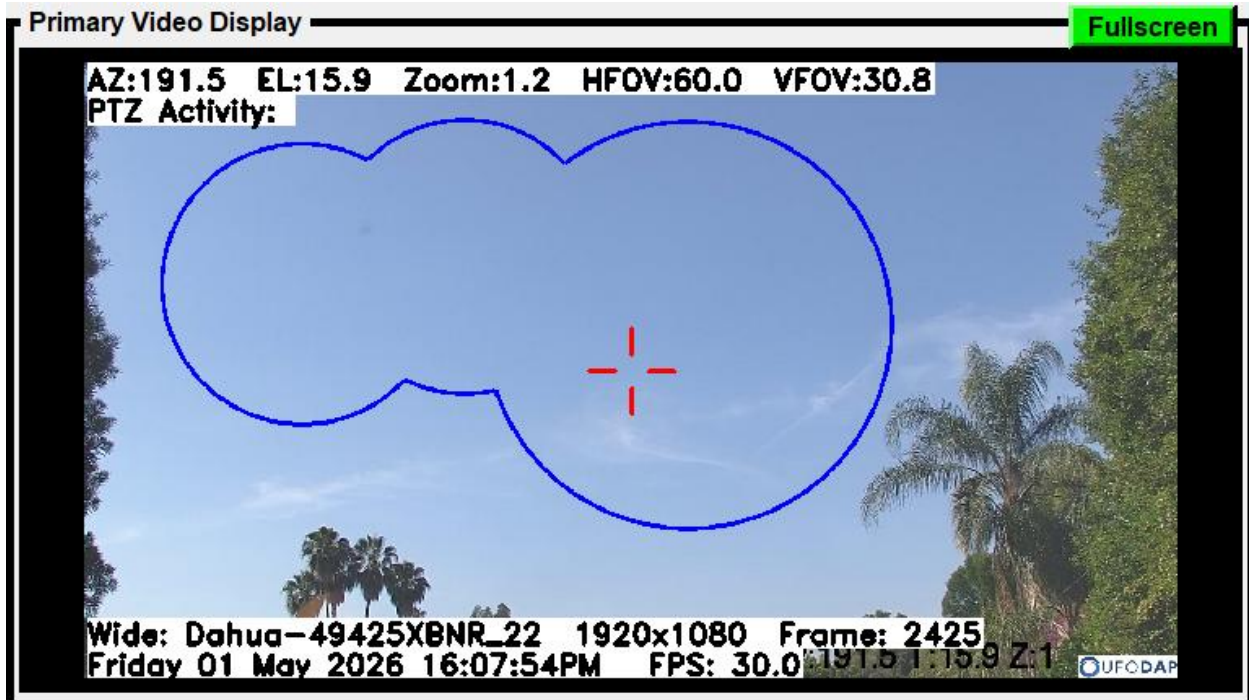

---

## Enabling Pan, Tilt and Zoom

The Enable Pan/Tilt and Enable Zoom check boxes may be used to enable those functions for a PTZ camera. If the Wide camera is not PTZ-capable, then Enable Pan/Tilt is ignored. However, enabling zoom will cause the Telephoto view to use digital zoom. In this mode, the telephoto view displays the portion of the Wide camera frame within the current bounding box, resulting in a digital zoom effect.

The Wide and Telephoto camera selections can be the same Camera Configuration but could be any combination of two cameras. For example, the Wide camera might be a 360-degree (“All-Sky”) type, and the Telephoto camera may be a PTZ type. In that case, the location of a detected moving object in the field of view of the Wide camera is used to continuously direct the view of the Telephoto camera to the same object.

If the System Configuration Wide camera is not PTZ capable, such as a USB type, and the Telephoto camera is PTZ-capable, then the PTZ Controls will apply to manual moves of the Telephoto camera.

If you would like to use an IP camera, PTZ or otherwise, that does not respond properly to ONVIF queries, then you can still use it as if it were a fixed-lens camera. To do this, use “nonptz” for the PTZ Driver entry in your Camera Configuration, instead of “onvifptz”. Alternatively, disable the “PTZ capable” checkbox in its Camera Configuration.

---

## Manual Recording

The Recording button allows the user to continuously record the Primary and Auxiliary recording options manually, without tracking if recording is enabled in the Recording options. The button is initially green and is labeled "Recording stopped". Any time after a System Configuration has been Loaded, Run is enabled and recording has been enabled via the Recording options, the user may click this button to start recording the selected views. When clicked, the button changes to red and displays "RECORDING". Click it again to stop the recording.

The recorded .avi files are written to the same folder as other recordings, as selected in the Recording menu. Each manually initiated recording opens a new folder named for the System Configuration with the date and time appended. Under that folder will be a video .avi file named, for example "otdau-wide-manual-date.avi" such as:

otdau-wide-manual-12-52-17.avi

OTDAU will continue to record camera frames to this file until the Recording button is clicked again, the configuration is closed or the OTDAU software is closed.

Normal triggered recording, as enabled by the "Enable recording" check box in the Recording menu, also causes the Record button to change color and label when an event causes recording to start or stop. Both triggered and manual recording states affect the color/label of the Recording button independently. The user may start or stop manual recording regardless of any triggered recording functions in progress.

## Camera Configuration

OTDAU -- Optical Tracking Data Acquisition Unit Version 2.27 4-1-26

### Camera Configuration

Camera type or "test": Dahua-49425XBNR\_22 PTZ Driver: onvifptz LAN address router or gateway: 192.168.1.1

Filename: C:/OTDAU/cameras/dahua-49425-130-1920x1080.json

IP address: 192.168.1.130 HTTP Port: 80 User: admin Password: dahua4942

Video URL: rtsp://admin:dahua4942@192.168.1.130:554/cam/realmonitor?channel=1&subtype=0&unicast=true&proto=Onvif

FPS: 30 Recording CODEC: XVID for .avi, MP4V for .mp4  PTZ capable Video Driver: USB, RTSP, HTTP, AVI, DSLR, PTDAU

Horiz FOV: 60.0 Vert FOV: 30.8 Maximum zoom: 25 Flip image -- 0:None 1:Up/Dn 2:L/R 3:U/D and L/R 0

Horiz Res: 1920 Vert Res: 1080 Channel (1 or 2): 1 Stream (0, 1 or 2): 0  Reverse continuous move

Pipe Res: 1920x1080, 1/2 960x540, 720p 1280x720 82 MB/s, 1280x720 Auto-detect Reload

Zoom distance in pixels to CFOV: 200 Zoom speed: 2

Zoom time limit: 2.0 Zoom restart interval: 1.0

Proportional constant: 6.0 Integral constant: 0.0 Derivative constant: 0.0

Clear Open Save Save As Close File Close Window

IP Camera Assisted Configuration USB Camera Assisted Configuration DSLR Information

The following is a list of all system configuration parameters found in each configuration file.

**Camera type or "test"** – Must be one of the following unique supported camera model identifiers, entered exactly as shown below OR as generated by the Camera Configuration Assistant (CCA):

- "Dahua SD50A230"
- "Dahua SD6AI445"
- "Dahua 49225"
- "Dahua 49425"
- "Dahua 50230"

- “Dahua 50232”
- “Dahua 50432”
- ‘Dahua 5A825”
- “Dahua 42212”
- “Dahua 4A425”
- “Dahua NK8BR4”
- “Dahua ASC”
- “Dahua N51BD22”
- “Dahua N53AB52”
- “Dahua N53CB62”
- ”Dahua N65CL5Z”\*\*
- “Hino IPC7F12”
- “Hanwha PNM-9013”
- “Hanwha PNM-9031
- “Hanwha XNP-9300”
- ‘Hanwha XNP-8300”
- “Hikvision 4A425”
- “Amcrest IP2M-841”
- “Axis M3025”
- “Samsung SNP-3370”
- “Samsung SNP-3750”
- “Sony RZ25N”
- “Sony SNC-RX570N”
- “Uniview IPC868ER”
- “USB x” where x is 0, 1, 2 or 3

\*\* The Dahua N65CL5Z seems to operate more reliably if the “IP address:password@” is not included in the Video URL, i.e.:

rtsp://192.168.1.110:554/cam/realmonitor?channel=1&subtype=0&unicast=true&proto=Onvif

“Dahua ASC” may be used for any 360/180 degree camera including the NK8BR4.

These types may also be names created by the Camera Configuration Assistant (CCA). See below for a full description.

Entering a Camera type that does not conform to any of the above values will result in an error displayed when the configuration is Loaded.

**Filename** -- Not user modifiable. Shows the filename for this configuration.

**IP** – The LAN IP address of the wide-angle camera as x.x.x.x. For example:  
192.168.1.108.

**HTTP Port** – The HTTP Port number of the camera, a two to four-digit number, typically 80. **Note:** This is not the RTSP port, which typically has a value of 554 and is used for video streaming. Rather, this is the camera’s HTTP port which is used for camera setup and motion commands.

**User** – Username to access the camera. Typically, admin’ but could be whatever user name has been assigned to the camera.

**Password** – Password to access the camera. The default will be provided by the camera manufacturer. It is changed to match Camera configurations provided with the OTDAU software when the camera is purchased but could be changed by the user via access to camera settings.

**Video URL** – The full URL required to stream video from this camera. Such URLs vary by camera and manufacturer. However, it can be manually modified and saved.

To select a particular USB camera regardless of what port it is plugged into, enter its name as the Video URL entry instead of a number. To find its name, open the camera using a number such as 0 or 1 as the URL. As part of the USB camera opening process, OTDAU will display a list of cameras it discovered. Replace the number with the exact text of the camera you want. You may also want to save this configuration with a name reflecting that specific camera. If a camera name is used as the URL, then it will be displayed for reference next to the resolution on the Wide and Aux displays.

**PTZ Driver** -- The name of the driver software provided with OTDAU or a customized version for a particular camera with controls that do not conform to existing drivers. Any camera that conforms to the ONVIF standard should use “onvifptz”. Current values may be:

- amcrest
- usb
- sony
- samsung
- onvifptz
- dahua
- testdriver

- nonptz (has the same effect as disabling pan/tilt and zoom in the System configuration)

**LAN (router or gateway) address** – OTDAU finds and displays the base address of your Local Area Network (LAN), also known as your router or Gateway address. This may be helpful to verify that the address used as the Camera IP address is correct, since the first three parts (octets) of that address must match that of the LAN address. (This is not the case when the camera is port-forwarded.)

**FPS** -- Camera Frames Per Second. Should match the camera's setting.

**Recording CODEC – XVID for .avi or MPV4 for.mp4** – The CODEC to be used to encode the video stream for recording. Should match the type of file to be created during recording – avi or mp4. XVID will produce an avi file. See the explanation of the differences between CODECs below.

**Video Driver** -- One of six choices, depending on type of video stream supported:

- USB -- for any USB camera
- RTSP -- for most IP cameras
- HTTP -- for IP cameras that do not support RTSP
- AVI -- for running simulated camera test files. Also used for MP4 files
- DSLR – for DSLR camera streaming frame capture via WiFi. Frames are at a lower, fixed resolution which is not the resolution used for normal camera photography, which is only saved to its SD card.

**Maximum zoom** – The maximum zoom value of the camera. The camera will stop zooming after this value is reached.

**Horizontal Resolution** -- Must match the camera's horizontal resolution.

**Vertical Resolution** -- Must match the camera's vertical resolution.

**Channel (1 or 2)** – Hybrid IP cameras may require the format of their RTSP URL to contain a selection for channel, for instance, to determine if the desired stream is from the EO (color/B/W) or IR cameras. This option is typically set to 1 for non-hybrid cameras. Select 2 for the IR camera stream. Verify your camera's web setup page for verification of these settings. **NOTE:** Open and Save any Camera configurations you plan to use to automatically set the initial Channel value to 1 and update the RTSP URL to match.

**Stream (0, 1 or 2)** – IP cameras can typically support more than one simultaneous output stream, each with a different resolution and other parameters as selected

in their Settings menu. These are the Main Stream (0) and Sub Streams (1 or 2). It is convenient to set the camera's streams to different values that may be of use and create (or use the provided) System/Camera configurations that correspond to those. Thus, alternate System configuration may be used with a camera without changing any camera Settings.

**Reverse Continuous move** -- Checked or unchecked depending on how the camera responds to continuous move commands. OTDAU issues continuous (velocity) movement commands after the absolute move stemming from an initial target detection event. If a camera moves in the wrong direction upon testing detection, then reverse this setting.

**Horizontal FOV** -- The fully zoomed-out horizontal field of view of the camera optics in degrees.

**Vertical FOV** -- The fully zoomed-out vertical field of view of the camera optics in degrees.

**PTZ capable** -- Set if the camera is pan-tilt-zoom or just zoom capable.

**Flip** -- Set if camera video frames need to be inverted horizontally or vertically due to mounting orientation. Use 0 for no change, 1 for flip vertical, 2 for flip horizontal and 3 to flip both vertical and horizontal. Image flipping may cause considerable CPU overhead due to this process operating on every frame.

**Pipe Resolution** — FPS optimization by user pipe resolution setting:

### **Why It's Needed**

OTDAU receives video from the camera through a Windows data pipe. At 4K (3840×2160) and 20fps, the raw video stream is about 500 MB/s — more than most PCs can move through a pipe reliably. When the pipe can't keep up, frames are dropped or delayed, which directly reduces the detection frame rate and can cause the camera stream to stall and restart.

The Pipe Resolution setting solves this by having the system scale the video down before it enters the pipe. The camera still records at full native resolution — only the stream used for detection and display is scaled. So a 4K camera can record in 4K while OTDAU detects objects at 1080p or 720p, which the pipe can deliver reliably at full frame rate.

### **How to Use It**

Enter the camera's native resolution and FPS in the Horiz Res, Vert Res, and FPS fields first.

Click Auto-detect — this measures your PC's actual pipe throughput and automatically selects the highest resolution that your system can sustain at the camera's target FPS.

If you prefer to choose manually, click one of the preset buttons. The MB/s figure updates instantly so you can see whether the selection is within your PC's capability (green = safe, orange = marginal, red = too fast).

Click Reload to restart the camera at the new pipe resolution. Detection and display will update immediately; recordings remain at full camera resolution.

The native resolution preset is fine for 1080p cameras on modern hardware. The Auto-detect recommendation is most important for 4K cameras or older/slower PCs.

**Zoom distance in pixels to CFOV** -- The maximum distance from the target image from the CFOV to allow the start of zooming in pixels. For example, if the zoom distance is set to 200 then zooming will start when the CFOV is brought within 200 pixels from the target.

**Zoom speed** -- The relative speed of zoom command sent to the camera when zooming is allowed.

**Zoom time limit** -- The period in seconds that the camera is allowed to zoom at the zoom speed each time zooming is allowed.

**Zoom restart interval** -- The minimum time in seconds that must elapse from the end of the zoom time limit until the next time zooming is allowed.

These four zoom parameters govern how effective zoom can be used by the system when zoom is enabled by the System configuration. The amount of zoom (the telephoto multiplier, x1 to x32 for example) will be higher if these parameters are more optimally set and how fast the target object moves and how long it loiters in a limited area.

Less optimal operation may occur if, for example, the zoom speed is too high, or the time limit is too long. In those cases, the offset of the target from the CFOV will more rapidly affect the distance of the object from the CFOV, causing the target to move away from view, possibly causing loss of tracking.

**Proportional, Integral and Derivative constants** – Controls for the PID loop that attempts to minimize the error between the position of the target in the image and the

center of the field of view. Typically, only Proportional is set to a value above 0. To adjust PID operation, begin with a low value, approximately 4, and attempt tracking with pan enabled. If the CFOV always lags the target location, then slowly increase this value, and try again. If the CFOV overshoots the target or moves back and forth over the target in ever larger distances until the target is lost, then reduce this value. An optimal value is indicated by the CFOV staying close to the target object and moving on top of the target if it stops.

**NOTE:** Per your camera's web page, in Setting -- If your camera ONVIF Authentication is ON, then the ONVIF Username and Password, defined in Account > ONVIF must match those used in the Camera configuration. Otherwise, if that camera is referenced in the initial Validation or during Load, then it will not validate or load correctly.

**NOTE:** Older cameras such as the Dahua 50230, 50232 and 50A320 respond to ONVIF queries for position much slower than more current models (in about 450msec vs 30-60 msec). This creates problems when attempting to maintain control in a PID loop which uses the difference between current position and target location. This version of OTDAU attempts to improve on this by automatically incrementing pan, tilt and zoom values based on commanded velocity of those axes while setting the position values to actual any time they become available. That is, position increments are filled in during periods when they are not available from the camera itself. This augmented statusing is only applied to the cameras noted above.

Wide-angle video records at native camera resolution (e.g., 3840×2160) by upscaling pipe frames before writing, matching the zoom recording resolution. Auto-switches codec from XVID to MJPEG for 4K frames since MJPEG is significantly faster for large frame sizes.

## **Control buttons**

**Open** – Opens a window into the Camera configuration file folder. Select a configuration by either double clicking on an entry or clicking an entry once and then click Open.

**Save** – Saves the current settings as part of the currently loaded Camera configuration.

**Save As** – Opens a window into the Camera configuration file folder. Saves the current settings as the Camera configuration but with a new name selected in this window. It is very useful to Open an existing configuration, modify its values, and then Save As with a new name to create a new configuration.

**Close File** – Terminates view of the last selected configuration and clears all entries. This has no effect on any cameras used in the currently open System configuration.

**Assisted Configuration** – Runs the ONVIF Camera Configuration Assistant, described below.

**Close window** – Closes the Camera Configuration window. If the window is closed before any changes to settings are Saved, then those changes are lost.

**IP Camera Assisted Configuration** – Opens the CCA, described below.

**USB Camera Assisted Configuration** -- Opens the USB configuration assistant, described below

**DSLR Information** -- Opens the DSLR camera information window, described below.

---

## A comparison of xvid, mp4 and avi

Xvid is a video codec, MP4 is a multimedia container format, and AVI is an older multimedia container format that holds video and audio. Xvid, which uses MPEG-4 Part 2 compression, makes files smaller by reducing their size with good quality. MP4, using modern codecs like H.264/AVC, is a flexible container that supports advanced features and smaller file sizes. AVI is a container that supports various codecs (including Xvid and DivX) but is less efficient in compression, resulting in larger file sizes and less advanced features compared to MP4.

### **Xvid**

What it is: A video codec that compresses and decompresses video content, with a focus on small file sizes and good quality.

How it works: It uses the MPEG-4 compression technique.

Pros: Achieves strong compression (up to 200:1), leading to smaller file sizes, which is good for storage and network transmission.

Cons: It's a codec, not a container, so Xvid files need a container format like AVI to be usable.

### **MP4 (MPEG-4 Part 14)**

What it is: A flexible multimedia container format designed to store video, audio, subtitles, and other data.

How it works: It uses advanced codecs such as H.264/AVC, which provide efficient compression.

Pros: Excellent for streaming and general use, supports multiple audio tracks and subtitles, and produces smaller file sizes than AVI for similar quality.

Cons: The "lossy" compression can sometimes result in slightly lower quality compared to lossless AVI formats.

### **AVI (Audio Video Interleave)**

What it is: An older multimedia container format that holds audio and video streams.

How it works: It uses various codecs (including Xvid and DivX) but is less efficient at compression than modern formats.

Pros: Can be lossless, offering very high quality for certain files.

Cons: Larger file sizes, less efficient compression, and a fixed, less flexible structure compared to MP4.

### **Key Differences Summarized**

Type: Xvid is a codec, while AVI and MP4 are container formats.

Compression: Xvid uses MPEG-4 Part 2, which is good but less advanced than the H.264/AVC used by MP4.

File Size: AVI files are typically larger than MP4 files.

Flexibility: MP4 containers are more flexible, supporting advanced features like multiple audio tracks and complex subtitles, which AVI lacks.

## ONVIF Camera Configuration Assistant

The screenshot shows a window titled "OTDAU -- Optical Tracking Data Acquisition Unit Version 2.26 10-23-25". The main heading is "ONVIF Camera Configuration Assistant".

**Status** Start by entering camera IP, port, user and password into the Camera configuration

Step 1 -- If camera IP/port/user/PW has been entered in the Camera configuration, test the camera for ONVIF connectivity:

**Test ONVIF connectivity**

RTSP URL

Manufacturer

Model

Serial Number

FPS

Motion control supported

Step 2 --  
Enter your camera maximum zoom from its data sheet   
Leave the default at 1 for fixed cameras

Step 3 --  
If PTZ supported, click Next until camera onscreen position shows exactly P:45 T:45 Z:3 then click Accept  
If only Z supported, verify zoom is set to 1 then click Next until zoomed image remains at x1  
If fixed (no PT or Z supported, Motion control is NONE), just click Accept

**Next** **Accept**

Transfer discovered settings to the camera configuration Close Window

This feature makes possible the use of cameras that are not on the documented support list. To operate an ONVIF camera with pan/tilt, OTDAU must convert degrees to a number between -1 and +1 for both position sensing and absolute position control. Since there is no ONVIF standard for these conversion equations, typically, they must be derived from testing using a sample camera. The new Configuration Assistant provides a means to determine the correct conversion equations for many cameras by a guided, semi-automatic procedure:

1. Open an existing Camera Configuration or just a blank Configuration window.
2. Enter the camera's IP, Port, User and Password.

3. Click Assisted Configuration – the Assistant will open. Follow the Status message directions – For Step 1, Click Test ONVIF connectivity. If the camera is accessible and ONVIF-compliant, its RTSP URL, Manufacturer and other information will be discovered and shown. The URL will be used to open its video stream on the Aux display.
1. Enter its maximum zoom value (from its datasheet) in Step 2 and then follow the directions in Step 3. This value is defaulted at 1 which is the minimum for any camera.
4. You can click Next as many times as needed; repeating tests as required to find the 1 of 9 best control algorithm.
5. When The camera video shows the correct position, click Accept. The Assistant now automatically tests each of 9 possible status calculations and finds the correct one. Note that more than one combination of calculations may work.
6. Click Transfer to rename the Camera type in the opened Camera configuration to incorporate the discovered control and status calculation.
7. Fill in the camera’s horizontal and vertical FOV from its datasheet (they are not discoverable)
8. Save or Save As the completed configuration.

The Camera configuration should now be usable in a System configuration. Note that prior Camera type names, such as “Dahua 42212” are also still usable and are converted to the new format via internal table lookup. The Assistant will work for PTZ, Z-only or non-PTZ cameras, indicating the type in the Motion control box.

The Camera type generated by this procedure is in the form:

“<manufacturer>-<model>\_<control calculation><status calculation>”

For example, the type for a 42212 camera can be the original “Dahua42212” or, using the CCA, “Dahua-42212TNI\_11”.

“Test ONVIF connectivity” may be started any number of times prior to Steps 2 and 3.

If a non-existent IP, port, user or password are entered, then an error message will be generated when the connectivity Test is started.

For example, after loading the Camera configuration of a 42212 camera, running Assisted Configuration and clicking Test ONVIF connectivity.

If you would like to use an IP camera, PTZ or otherwise, that does not respond properly to ONVIF queries, then you can still use it as if it were a fixed-lens camera. To do this, use “nonptz” for the PTZ Driver entry in your Camera Configuration, instead of “onvifptz”. Alternatively, disable the “PTZ capable” checkbox in its Camera Configuration.

## USB Camera Assisted Configuration

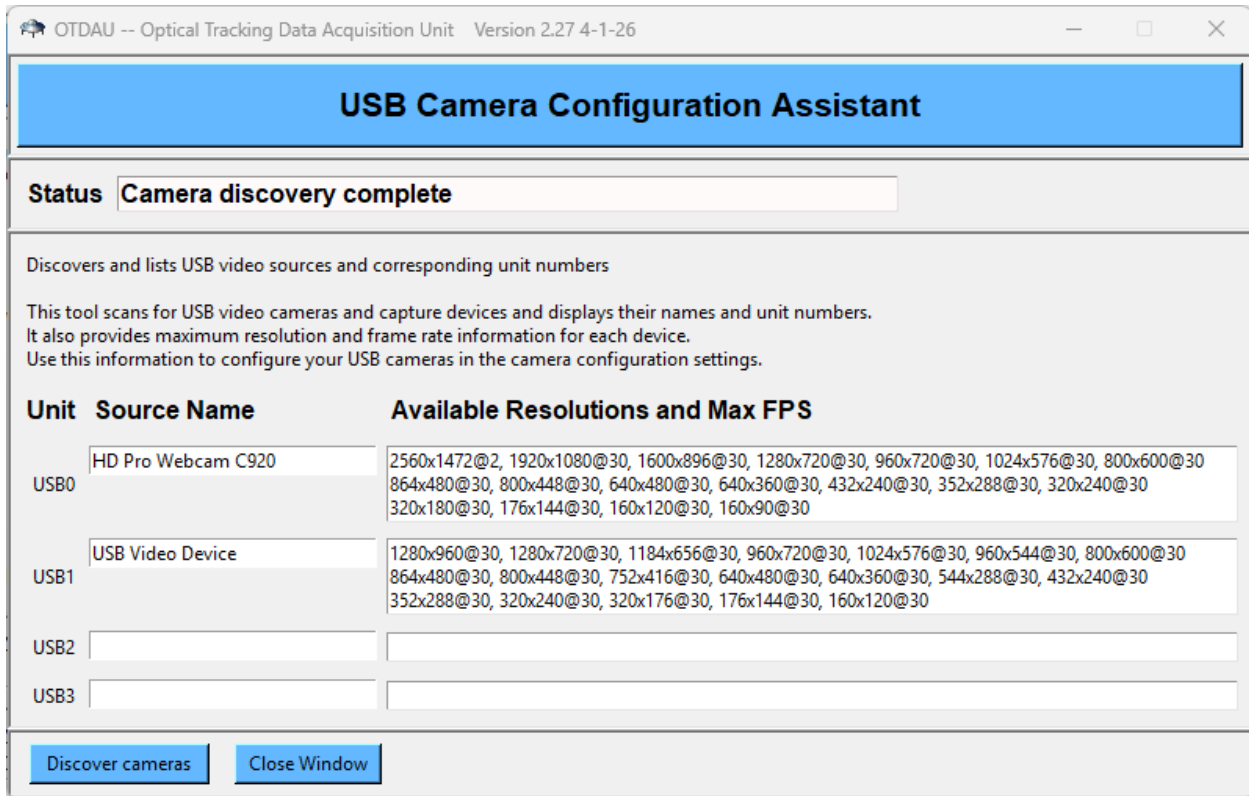

The USB Configuration Assistant (USB-CCA) will automatically discover and display any camera-type USB devices when it is opened or by clicking the Discover cameras button.

The USB-CCA provides information and verification of USB-interfaced cameras as well as video capture devices you may want to use for input from composite video cameras or HDMI sources. This function lets you know which device to use in a configuration (USB0, USB1,...) regardless of how Windows assigns USB devices. It also validates the maximum usable resolution and FPS of each device for proper camera configuration entries.

When the CCA is run by clicking Discover cameras, all attached USB cameras are detected and tested for all available resolutions and corresponding FPS for each. Then, if any USB camera is loaded, a mismatch between its configuration values for resolution and FPS can be compared to what the associated camera is capable of. If there is a mismatch, then a fault message provides the details of what needs to be modified for a successful load. If a USB camera is loaded prior to running the USB CCA, then the

CCA is automatically invoked to determine all attached camera characteristics. When that is completed, just close the CCA and load the required camera again.

## DSLR Information

OTDAU -- Optical Tracking Data Acquisition Unit Version 2.26 10-23-25

### DSLR Camera Configuration

**Camera View**  

Camera information: Canon.Inc Canon EOS M50m2

WiFi SSID: rholch24      LAN (router or gateway) address: 192.168.1.1

IP address: 192.168.1.160      HTTP Port: 80

Lens: EF-M15-45mm f/3.5-6.3 IS STM      Still aspect ratio: 3:2

Storage: sd Photos: 25      Battery or Adapter: DR-E12

Shooting Mode: a+      Snapshots + Shots taken during Run: 7

Shooting Mode dial setting

Get Info    Snapshot    Close Window

OTDAU supports use of Canon Digital Single Lens Reflex (DSLR) cameras that comply with the Canon CCAPI programming interface.

A list of Canon cameras that support CCAPI includes, but is not limited to, the following models:

### EOS R Mirrorless Series

- EOS R
- EOS Ra
- EOS RP
- EOS R3
- EOS R5
- EOS R5 Mark II
- EOS R6
- EOS R6 Mark II
- EOS R7
- EOS R8
- EOS R10

- EOS R50
- EOS R100
- EOS R50V
- EOS R1

### **EOS DSLR Series**

- EOS-1D X Mark III
- EOS 5D Mark IV
- EOS 6D Mark II
- EOS 77D
- EOS 80D
- EOS 90D
- EOS Rebel SL3 (EOS 250D / EOS 200D II)
- EOS Rebel T8i (EOS 850D / EOS Kiss X10i)
- Many older models like the EOS 5D Mark II, EOS 7D, and various Rebel series cameras also have some level of CCAPI support through the developer kit.

### **EOS M Mirrorless Series**

- EOS M6 Mark II
- EOS M50 Mark II
- EOS M200

### **PowerShot Series**

- PowerShot G5 X Mark II
- PowerShot G7 X Mark III
- PowerShot SX70 HS
- PowerShot V10
- PowerShot ZOOM

However, OTDAU DSLR software was developed and tested only on the EOS M50 Mark II camera. Thus, there is no guarantee that any other of the above cameras will function correctly. OTDAU will provide an error message if commands to the camera do not function correctly.

Prior to use, set up your camera for WiFi connectivity to a computer using these instructions, 1-10:

[https://cam.start.canon/en/C007/manual/html/UG-08\\_Wi-Fi\\_0050.html](https://cam.start.canon/en/C007/manual/html/UG-08_Wi-Fi_0050.html)

In Step 2, be sure to select the top, center icon (a PC).

Set the rotary function switch to A+ (not video).

After Loading a System configuration that uses a Canon camera, click the “Get Info” button shown above to acquire settings and status from the camera. Continuous still frame captures will also be shown on the left display. These frames will also be displayed on the Wide Video Display like any other camera.

The frame rate is rather low at about 4FPS. This is adequate for checking that the camera is operational with a FOV as expected. It will work for tracking but only for low-speed targets.

DSLR camera information includes:

**Camera information** – The manufacturer name and camera model number

**WiFi SSID** – The SSID of the WiFi connection

**LAN (router or gateway) address** – The detected subnet or LAN address in use. For debugging the connection, use this to verify that the camera default static address (192.168.1.160) is in that LAN.

**IP address** – Verifies the expected address of the WiFi connection.

**HTTP Port** – Normaly 80.

**Lens** – The lens type in use.

**Still aspect ratio** – The still frame aspect ratio.

**Storage** – Storage type, typically “SD” and the number of shots saved.

**Battery or Adapter** – The type of battery in the camera or the model number of a battery adapter.

**Snapshots + Shots taken during Run** -- A count of the number of shots taken both manually (using the Snapshot button) and automatically by the Recording selection.

### **Control buttons**

**Get info** – If the camera has been opened by Loading a System configuration that includes it, communicates with the camera to acquire the data shown.

**Snapshot** – Causes a shutter release.

If the camera Mode dial is set to anything except Movie mode, you will hear the mechanical shutter and a green box will temporarily surround the Camera View area. The characteristics of the shot, such as resolution, are set manually by the user.

If the camera Mode dial is set to Movie mode, video recording will start and automatically stop after two seconds.

**Close Window** – Close this window.

## Camera configuration Setup Options

OTDAU supports input from and displays of either one or two simultaneous camera video streams. These are displayed on the left Wide-Angle Video pane and the right Auxiliary (Aux) Video pane. It also supports Pan-Tilt-Zoom operation of cameras capable of such motions via their CGI command set or via internationally standardized ONVIF commands.

Supported combinations of cameras and displays are as follows:

**One camera:** Selected in a System configuration File as both the Wide-Angle and the Telephoto camera. In this case there are several operational possibilities, depending on camera type:

1. The camera is not PTZ-capable, such as a USB camera or it is an IP camera with PTZ disabled. The camera image will be displayed on the Wide-Angle pane including textual meta-data superimposed on the image. On the Aux pane, there are four selectable display sources:

- Raw Video: The video image without any superimposed text.
- Telephoto: The video image with abbreviated text. The image will be the portion of the Wide-Angle image that is within the Bounding Box, which simulates digital zoom.

Digital zoom defaults to a fixed 5x zoom. Zoom can be adjusted from x1 to x10 using a sliding control in the Setup > Display window. The zoom amount may be changed at any time, whether in Run or not. Try it by loading a test file and opening the Display Options. Then while viewing the Telephoto display, adjust the zoom level and Save. The digital zoom level in the display will change and the level shown at the bottom of the screen.

- Tracking: The wide-angle video image as processed by the tracking algorithm showing what contours the system is using to identify a target. This display may be helpful when setting analysis parameters to improve target identification and tracking. White areas may display intermittently show where the system sees a potential target that may or may not be accepted.
- Path: The Wide image overlaid with green boxes indicating each time the tracker identifies the moving object and its relative size. This is very useful in

determining the track or motion of an object that may be too fast or small to know otherwise.

- Spectrum: A line spectrum resulting from use of an optical grating in front of a camera lens is automatically detected and converted to a graph of power vs wavelength, displayed. This option will be usable after a suitable grating assembly and any further software additions are made available after completion of development.
2. The camera is PTZ-capable and PTZ is enabled. This case is like 1 except that the Telephoto display is the full video of the Wide-Angle camera, and the superimposed text includes azimuth, elevation and zoom values.

**Two cameras:** Selected in a Configuration file, either static or PTZ-enabled. Typically, in this case, the Wide-Angle camera is a fixed camera (or a PTZ camera is used without PTZ enabled) to focus attention on an area of interest. The relative location of a target on this camera is used to direct the Telephoto camera to point at the target. The Aux pane thus displays the target as close to the center Field of View (FOV) and as zoomed in as the system can track given the target dynamics. This case includes the application of either a fixed or an “All-Sky” type of camera and a PTZ camera with 360-degree pan capability.

To set up a two-camera system where the second camera is PTZ-capable, prior to running, start by enabling FOV calibration marks in the Setup > Display Options. Then move the initial position of the PTZ camera so that its Center Field of View (CFOV, as indicated by the red crosshairs) is aligned with the CFOV of the fixed camera. A laser pointer may be helpful to establish a common point of reference for both cameras. Verify that a test object moving left-right and up-down near the CFOV of the fixed camera moves in the same direction in the Telephoto view of the PTZ camera. If not, rotate either camera to achieve this alignment.

Another two-camera configuration is used for triangulation. In this case, both cameras may be fixed or PTZ-enabled and are operated by two separately running copies of OTDAU. Both cameras independently identify and track moving objects and their data is combined by the Mission Control software to provide a true position estimate of the target. Note that any combination of the OTDAU instances and MC could run on the same or different computers if the addresses and port numbers are set correctly in the OTDAU System configuration and corresponding MC Sensors configurations.

## USB camera setup

Most USB cameras and other USB-interfaced video sources require a driver to be installed prior to use. The driver would be provided by the camera manufacturer.

Use a utility provided as part of the manufacturer's software to determine or modify the camera's operating settings. For example, change the horizontal and vertical resolutions. Values for resolution and frame rate must match those entered in the camera's Camera Configuration. The current version of OTDAU software automatically configures USB cameras to the resolution specified in the Camera configuration, if possible. An error message will appear if the camera does not support the selected resolution.

Any USB camera will work with OTDAU. Just be sure to select a resolution that the camera can produce. A camera that only provides a composite analog video output can be interfaced to OTDAU via an analog to USB interface device. One such device that works well for this purpose is the USB-Live 2 Analog Video Digitizer from Hauppauge.

OTDAU attempts to set the resolution of a USB camera to the values entered in its Camera configuration.

If you have difficulty acquiring an image from a USB camera (or analog-to-USB converter), try connecting via a program other than OTDAU. Three helpful resources are:

- VLC Media Player – connect via its Media > Open Capture Device feature to stream video from a camera.
- WebcamViewer – Automatically shows connected USB devices to select from. Just select the resolution and click Connect. You can find this free tool at:  
[www.bustatech.com](http://www.bustatech.com)
- Webcamtests.com – Just select the video input (corresponding to a camera USB port) and click "Test my cam". This online test will display the video stream as well as list all the specs/characteristics of the camera selected.

After verifying that the camera functions on the computer running OTDAU, proceed to create a Camera Configuration for it or use one of the USB0, USB1 or USB2 configurations provided with OTDAU, as shown below.

A System configuration that uses this USB camera might look like:

OTDAU -- Optical Tracking Data Acquisition Unit Version 2.23 12-10-23

### System Configuration

System Description: Local USB0 camera - 640x480 Port 51000

Start time: 00:00:00 Stop time: 23:55:00

Wide-Angle Camera: usb0-640x480

Telephoto Camera: usb0-640x480

Pan/Tilt Unit:

Bound X1: 189 Bound X2: 425

Bound Y1: 102 Bound Y2: 389

Maximum zoom: 20

Operator Name: Your Name

Enable Pan/Tilt:  Enable Zoom:  Enable Sound:

#### OTDAU - Mission Control communication address selection

Computer IP address  
127.0.0.1 if OTDAU running on same computer as MC else, use static IP of OTDAU computer

Computer port (49152 to 65535): 51000

Open configuration Save Save As Close File Close Window

Open a video file for test

## IP Camera setup

Setting up an IP camera for use with OTDAU involves several steps that, if done carefully and in order, will make it a reasonably simple process.

Please see the UFODAS System Installation Guide for IP camera hardware setup and configuration.

After verifying camera connectivity and operation it may be used with OTDAU by creating a camera configuration, for example, as shown below for a Dahua 42212 camera set to a resolution of 1920x1080.

A System configuration that uses this Camera configuration might look like this:

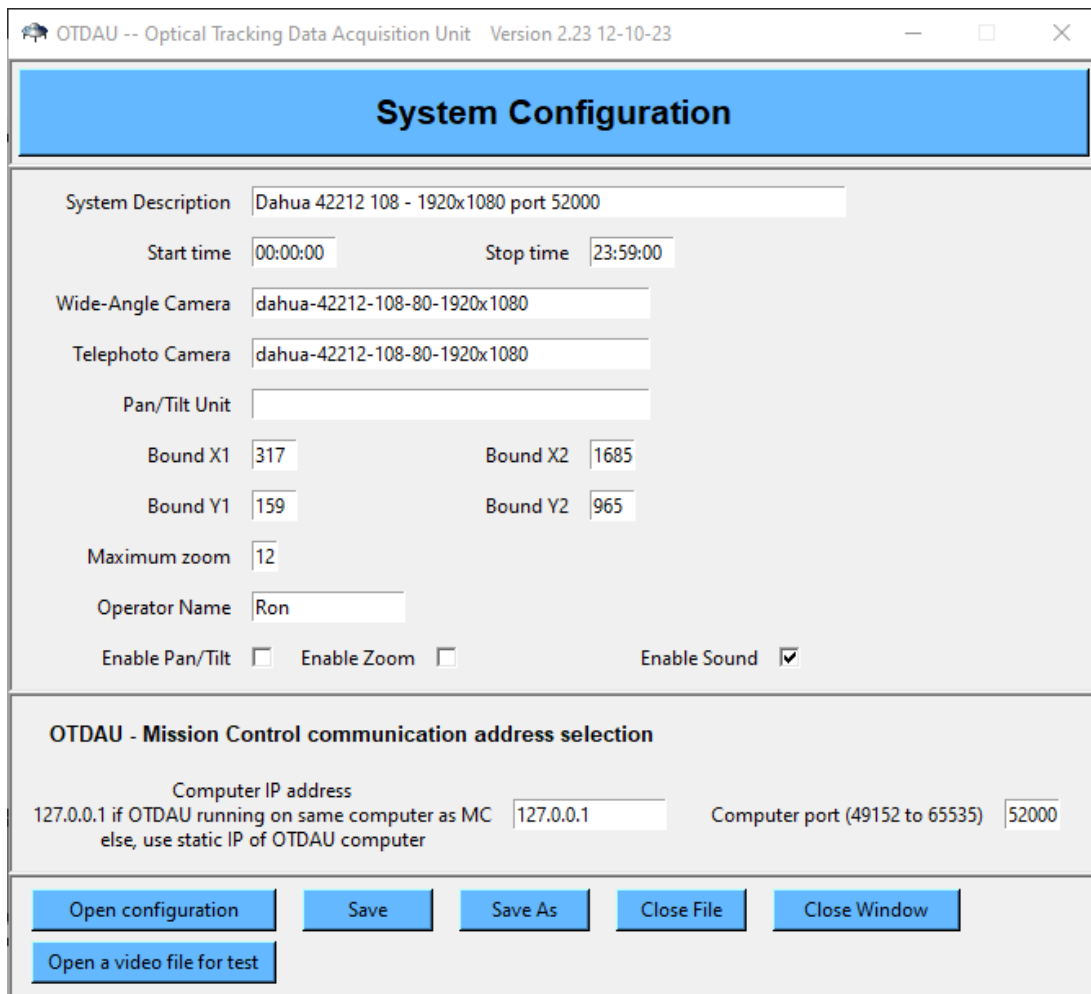

The screenshot shows the 'System Configuration' window of the OTDAU software. The window title is 'OTDAU -- Optical Tracking Data Acquisition Unit Version 2.23 12-10-23'. The main title is 'System Configuration'. The configuration fields are as follows:

- System Description: Dahua 42212 108 - 1920x1080 port 52000
- Start time: 00:00:00
- Stop time: 23:59:00
- Wide-Angle Camera: dahua-42212-108-80-1920x1080
- Telephoto Camera: dahua-42212-108-80-1920x1080
- Pan/Tilt Unit: (empty)
- Bound X1: 317
- Bound X2: 1685
- Bound Y1: 159
- Bound Y2: 965
- Maximum zoom: 12
- Operator Name: Ron
- Enable Pan/Tilt:
- Enable Zoom:
- Enable Sound:

OTDAU - Mission Control communication address selection

Computer IP address  
127.0.0.1 if OTDAU running on same computer as MC else, use static IP of OTDAU computer: 127.0.0.1

Computer port (49152 to 65535): 52000

Buttons: Open configuration, Save, Save As, Close File, Close Window, Open a video file for test

Since this camera supports pan/tilt/zoom functions, the Pan/Tilt and/or the Zoom choices could be enabled and Saved prior to Run to allow those functions to be used for manual or automatic tracking purposes.

---

## IP camera setup problems

Some typical problems with IP camera setup and OTDAU configuration include:

- The Ethernet connection from the camera to the PoE injector or the cable is faulty or the connection from the injector to your router is incorrect.
- The camera IP address and port are set to values that are not the same as those in the camera's configuration file.
- The camera's IP address conflicts with another device on the same LAN. Use the Dahua ConfigTool or similar Lumany's LumiViewer or Uniview EZTools to check for this – it will highlight two conflicting cameras in red if they have the same IP address. A typical problem is that the range of DHCP addresses that the router uses to automatically assign IP addresses to non-Static devices overlaps your camera's IP address and the router used that address. If this is the case, modify the DHCP range to, for instance, 1 to 99 so that your camera's IP, such as 108, is not within that range.
- If port-forwarding via the router, the port number selected in the camera is not available to be forwarded in the router.
- The video resolution selected in the camera's setup does not match the camera's OTDAU configuration.
- The camera's codec is not set to XVID, MPEG4 or MJPEG, but rather JPG or H.265 for example. Use H.264 instead of H.265 for better compatibility with OTDAU code. This is because setting main stream encoding to H265 in some Dahua camera firmware builds may cause the camera to respond to ONVIF queries for capabilities to be incomplete, resulting in OTDAU assuming the camera has no PTZ ability. If this seems to be the case, use H264 instead of H265.
- Python ONVIF libraries can generally handle special characters in camera passwords, but issues frequently arise because the underlying camera firmware or the SOAP/XML communication layer fails to properly encode or parse them. Characters like @, &, !, and non-ASCII symbols often cause authentication failures or connection errors. **Recommendation:** If you encounter errors, sanitize the camera password to use only standard alphanumeric characters (A-Z, 0-9) and basic punctuation to ensure compatibility with ONVIF standards.

- The video stream HTTP string entered as the Video URL in the camera configuration has an incorrect user, password, IP or port number. It may also not comply with the URL format required by the manufacturer for that camera.
- If the PTZ camera will not initially acquire a target image but instead makes an initial movement away from the target position, verify that the value of the Absolute move direction check box in the PTZ camera configuration is correct. Reverse it and try again, preferably with a test object or the laser-on-the-wall method.
- If the PTZ camera makes uncontrolled continuous movements after target acquisition, check the setting of the Continuous move direction check box in the camera configuration. Also check that the Proportional velocity setting is not too large. The correct setting will cause the camera to smoothly track a moving object and, when the object slows or stops, moves it to the CFOV. An incorrectly large setting will result in “hunting” or constant back-and-forth movement of the camera CFOV about a static target location. If it is sufficiently larger than this stable setting, then the camera will move away from the target location, possibly encountering other background objects which cause additional triggers and even more loss of control.
- If the image tends to defocus (and loose track) during zooming, then it may be that the camera’s autofocus function is not adequate for OTDAU zooming or is too slow or does not focus properly in low-light conditions. Prior to use, it is usually best to set the cameras zoom option to Manual and then set focus as follows:
  1. In daytime lighting, center the camera FOV on an object with sharp edges or writing.
  2. Zoom to maximum, moving pan or tilt to keep the object in the center of the frame.
  3. Operate the +/- focus control to bring the object into as sharp focus as possible. Iterate between steps 2 and 3 to get the best focus.
  4. Notice that now the object and other parts of the view will stay in focus regardless of zoom level.
- Problem connecting to ONVIF cameras that cannot disable ONVIF Authentication or Authentication is enabled: This problem may not occur if the camera Time Zone and Current Time exactly match that of your PC (use

Sync PC to set time). For Dahua cameras, go to System > General > Date & Time to set the Time Zone and Current Time. Correct connection will be made if the time is synchronized or Authentication is turned off.

- If when Validating your license/system, either initially or via Help > Manage License, you get a message such as: “Selected camera is not accessible” or “Could not connect to ONVIF camera -- check IP, port, username or password” then your camera may not have an ONVIF user set up. For Dahua cameras, for example, go to the System > Account > ONVIF User section of your camera’s webpage and look for a place to add an ONVIF user. Use the same username and password to set up an ONVIF user as you use for the camera. Be sure to use the same Group Name used for the non-ONVIF account, typically “admin”.

**Note** that it is not required to enable ONVIF Authentication as found, for example for Dahua cameras, in Network > Access Platform > ONVIF. Some cameras default to some type of authorization, which is acceptable.

## Common IP camera configuration problems

If OTDAU will not recognize your camera after configuration and Load or if you get the error message 'Could not open wide RTSP camera', then you may want to check for the following camera and system configuration problems:

- IP address in the Camera configuration in either the IP or Video URL entry or both does not match the IP address of the camera.
- The User and/or Password entries are incorrect.
- The IP, Port, User and Password are correct, but they were changed and then the Camera Configuration was not saved.
- The port number entered in the Camera configuration does not match the camera's HTTP port number or the camera's port was not set to the expected port number in the camera's setup menus, accessed via IE.
- If the camera is accessed remotely via the Internet by port-forwarding, then verify that the IP address used in the Camera configuration is the camera's WAN address, not its LAN address (192.168.1.x). Verify that the camera has been properly port-forwarded using its correct IP address and port number in the router which is local to the camera (which it is directly connected to by wire or WiFi).
- The Camera type in the Camera Configuration is not one recognized by OTDAU.

If the computer running OTDAU is connected to the same local router as the camera (they are on the same LAN), then verify that the IP address used for the camera is its local (LAN) address, i.e., 192.168.1.x.

The Camera Configuration Assistant function of OTDAU has been provided to help resolve such issues and automatically identify the correct RTSP URL and ONVIF control and status functions.

**NOTE:** Setting IP camera mainstream encoding to H265 in some Dahua camera firmware builds may cause the camera to respond to ONVIF queries for capabilities to be incomplete, resulting in OTDAU assuming the camera has no PTZ ability. If this seems to be the case, use H264 instead of H265.

---

## Setup for All-Sky (panoramic) Camera

OTDAU supports IP and analog cameras with ultra-wide-angle lenses, also known as All-Sky Cameras (ASC) or panoramic cameras. An ASC may be used alone or in combination as the Wide camera with a second Tele camera.

If the tele camera is PTZ-capable, then it will operate in one of two modes – slaved or handoff. With the Setup Handoff option disabled, the PTZ camera pan, and tilt angles will be slaved or incrementally moved to match the calculated approximate direction of the target based on its location in the Wide camera FOV.

If Handoff is enabled, then the initial calculated target position is used to move the PTZ camera to those pan/tilt angles and then hands-off subsequent tracking to the PTZ camera. At handoff, the PTZ camera is moved such that its FOV is approximately centered on an estimated target position. The PTZ camera then begins its own target detection resulting in a second absolute move of the target to its CFOV, this time more accurately. It then continues to track the target in a continuous, velocity feedback mode.

Because the handoff position is more of an estimate than when a PTZ camera would have made the initial recognition, the Crop increment value in Tracking Settings should be set larger than usual. For example, set it to 10.0 instead of 5.0. The system will automatically reduce the crop or bounding box around the target after the PTZ camera locks onto the target itself.

When using an ASC, you may notice that some smaller objects you can see visually do not seem to appear on the ASC Wide-Angle display. This is possibly because so much of the visual field is imaged by the ASC that objects visually observed near the horizon occupy too few pixels on the image. On an ASC, the closer to the horizon (its worst case), the more the field is compressed.

This website provides a size/distance/angle relationship:

<http://www.astro.ex.ac.uk/people/hatchell/rinr/sizeangle.pdf>

Which is  $x = r a \pi/180$  where  $x$  is the size of the object,  $r$  is the distance to it and  $a$  is the angle subtended by the object to an observer.

As an example, for a small aircraft,  $x$  might be 20'. Say the distance from the observation area to an aircraft is about 4000'. So, the angle the aircraft subtends would be 0.28 degrees. Assume that the ASC was set to resolution 2048x1536. That would result in about 2000 pixels per 360 degrees. The aircraft would then cover only 1.5 pixels and thus would not be visible. In contrast, a non-ASC camera with a horizontal

FOV of 60 degrees, at resolution 1280x720 would provide 1280 pixels per 60 degrees. This would result in the aircraft covering nearly 6 pixels and thus probably be visible on the display and detectable by OTDAU. Note that these calculations are for the worst-case condition of an object near the horizon. The closer an object gets to the CFOV of the ASC, the less reduction in size/pixels will occur. Thus, a particular ASC may be rated for 180/360-degree coverage, but not all that area may be useful. Additional calculations or experimentation may be required to determine how much of the FOV of an ASC would be useful.

---

## Setup for dual cameras

OTDAU can be configured so that the wide-angle and telephoto cameras are not the same. Each one can be any type of camera OTDAU supports. Typically, the same camera configuration is used for both, for example, USB0 or a PTZ camera.

If the single camera is USB, then that camera's video will appear on both the Wide-Angle Video Display and the Auxiliary Video Display regardless of the sources selected. All tracking functions will work but, of course, no PTZ action is possible.

If the single camera is a PTZ-capable unit, then its video stream will also be used on both displays. However, the Auxiliary on-screen data will vary depending on the source selected. Raw video may be selected to eliminate all on-screen data, for example.

If different cameras are used for the wide and tele configurations, then the wide camera stream will be used for all displays except the Telephoto source selection. Note that these same four selections are available for recording.

A particularly useful System configuration consists of two cameras where the Wide camera has very wide-angle fixed optics and the tele camera is a PTZ unit. In this configuration, OTDAU will use the relative position of a tracked object on the wide camera to direct the pointing angles of the PTZ camera at the same object. As tracking progresses, the PTZ camera will incrementally zoom in the same manner as for a single PTZ camera configuration. If Handoff is enabled, then the Tele camera will perform its own object identification and then continue to track as if it were the only camera. If Handoff is not enabled, then the Tele camera will make a series of incremental moves to each x, y coordinate provided by the Wide camera as it tracks the object. In this case, the Tele camera is slaved to the Wide camera instead of controlling itself.

In the case where the wide camera is a panoramic or "all-sky camera" (ASC with up to 360-degree optical FOV), some special setup steps are required to align the PTZ camera FOV with that of the wide camera. For the ASC to provide the PTZ camera with the correct estimated pan/tilt values, the system must be calibrated prior to use. The initial position of the PTZ camera must be related to the ASC by the following process:

1. Try to mount the two cameras so that their lenses are as close together and at the same height as possible. However, given the typically long distances to a target object, a difference of a foot or two is not very consequential.
2. Enable handoff calibration marks in the Setup > Display menu.
3. Load OTDAU with the dual-camera configuration and set the Auxiliary source to Telephoto. Verify that you can see the views from both cameras. Set the

Auxiliary Video Display to Raw Video. Use Flip = 0 for the ASC camera configuration.

4. Rotate the wide camera so that the horizon is parallel to the lower part of its FOV.
5. Using the PTZ Controls, move the tele camera down and rotate so that it displays the wide camera's view centered in its FOV. Use the Setup > Enable FOV calibration marks to help align the marks of both cameras. Using PTZ Controls, move the PTZ camera so that tilt is 0 degrees (horizon) and pan is such that it is aligned with the bottom of the ASC view direction.
6. Use the Pan control to manually move the PTZ camera so that its Center Field of View (CFOV) crosshairs are over the same view as that of the Wide camera.
7. Optionally, Enable Handoff in the Setup menu. If enabled, when a target is detected in the Wide camera, the Tele camera will be pointed in the same direction and begin its own detect/track process. Both camera's video streams will be recorded, if enabled. If Handoff is not enabled, then the Tele camera is "slaved" to the target location in the Wide camera FOV. It will incrementally move as the target moves in the Wide camera FOV.

The system is now ready to Run.

---

## Setting focus for night sky tracking

When setting up a PTZ camera for use in night conditions, it is particularly important to verify that the image will stay in focus during zoom-in to the tracked object. Otherwise, as the camera incrementally zooms into the object, it may become unfocused and possibly lose tracking lock.

One method to avoid this problem is to set up the camera so that it retains focus at any zoom level using the following procedure:

1. Open the camera's web page using a browser such as IE via the Dahua ConfigTool. (See the UFODAS System Installation Guide for how to do this.)
2. Select Setting, Camera, Conditions and then Focus & Zoom
3. Set Digital Zoom to Off, Zoom Speed to 100, Mode and Focus Limit to Auto, Sensitivity to Default and PFA to On
4. Using the pan-tilt control arrows in the lower left corner, move the camera so that there is some identifiable object, such as a tree, in the center of the field of view.
5. Use the +/- Zoom buttons to zoom into the object to the maximum zoom telephoto zoom level. If the object gets too out of focus during zoom, adjust focus with the +/- Focus buttons.
6. Adjust the image for best focus at maximum zoom (for example, x12 or x30 depending on the camera.)
7. Zoom back to x1 and verify that the image stays in focus throughout the zoom range.
8. Click Lens Init in IE to verify that the camera will retain a sharp image after resetting its focus and zoom.

---

## Data interpretation and adjustments

OTDAU accomplishes tracking by means of a two-phase process:

1. **Detect** motion of an object that moves with respect to the background. Reject detections from objects that move too fast or are outside of size limits. Reduce the bounding box to an area that only surrounds the detected target object.
2. **Track** the target by rapid re-detections only in the smaller detection bounding box until no further detections occur for a set period.

In the optical environment of an OTDAU there will inevitably be many sources of false positive tracking events. The source of those events includes:

- Foliage such as trees moving in the wind.
- Significant dirt spots on the camera lens or on a window if the camera is used inside a structure.
- Certain geometric shapes in clouds.
- Significant movement of water or reflections off a body of water.
- Birds and large or close insects.

Of course, aircraft and helicopters moving through the field of view will also be tracked. In this case, such events may be of some value as they may be associated with another unknown event collected close in time. Tracking aircraft is particularly useful for calibrating the system and verifying that to some extent, the system is set up appropriately for ambient conditions.

Higher frame rates are valuable in terms of the fastest object motion that can be captured.

However, the highest practical frame rate does not need to be higher than the rate at which the OTDAU software can process those frames -- otherwise the extra frames are redundant.

The processing frame rate is a function of the speed of the computer and communications paths between it and the camera. This means that there is no fixed answer to determining camera resolution and frame rate without considering the other factors.

However, you may find that it is practical to operate a camera at 20 FPS, sometimes trading that off against a lower resolution such as 704x480. The key issue to bear in mind is that OTDAU uses zoom to effectively increase the number of pixels to image an object rather than depending on the camera's imager resolution alone. The value of an

imaging chip with a higher resolution, larger size and more sensitivity is improved ability to make the initial target recognition when an object is smaller (i.e., some combination of farther and smaller) and in dimmer light if the target is not self-illuminated.

**Note:** You can start a scanning run at a zoom level other than x1. Whenever OTDAU goes into the Run mode, it captures the current pan, tilt and zoom levels as the Home position. It returns to that position after each tracking event. The zoom level can start at any value the camera provides. If zoom is selected in the System Configuration, then zoom is incrementally increased until the selected maximum value. It will not decrease until the event is over when it returns to the Home value.

Due to lag in camera motion, a moving object will not be at the initially detected position by the time the camera moves its center FOV to that position. Simply expanding the crop (Tracking, crop increment) may be adequate but would often catch surrounding clutter close to the object instead of the desired target. OTDAU makes the initial move to the future predicted location of the object. It does this by sampling object motion just after detection and calculating its velocity and direction of motion.

When using a PTZ camera, the first move after target detection is a rapid absolute move to try to place the target at the CFOV, as described above. For every other target detection thereafter, during tracking, the system controls the PTZ velocity in a closed loop to move the CFOV toward the target, minimizing the difference between the target's location in the image and the CFOV. However, the speed of the target may be sufficient so that the CFOV always trails the target. At every frame, OTDAU measures the total non-contiguous size of moving areas within the bounding box. If that total is below the Min area or exceeds the Max area, there is no detection. At the same time, if the total area exceeds 10x the Max area, then tracking is aborted due to clutter.

The Auxiliary Video Display, Telephoto selection displays a 100x100 pixel digital zoom of the center of the camera frame when scanning or a digital zoom of the crop around a tracked object. This helps identify transient objects that fly by but do not trigger tracking as well as tracked objects. Since the last frame of the triggering event is retained on the display after the sequence ends, this feature helps identify what caused the system to detect the event. This feature may be used along with higher values of the Min events Tracking parameter to reduce false triggers.

See the discussion of Tracking settings for further information.

---

## Testing otdau setup and tracking

In addition to trying the various “test-x” System configurations, using a laser to test tracking is a very effective way to simulate actual targets and see how OTDAU responds.

However, the problem is the following:

- OTDAU uses a process of predictive location to determine where to make the initial absolute move upon detection (the PID loop continuous velocity control is used after that).
- The predicted position is derived from measuring the vector velocity of a potential target during the number of frames specified by the Tracking, "Min events" parameter. After that number of detections are measured, it uses the estimated lag time of the software/camera to derive what the target location will be in the future and move to that point.
- Thus, while the system sees the laser, if you make some quick motions (high velocity), then it predicts what may seem to be odd future locations some distance from the laser spot.
- Thus, to do that kind of testing requires a very steady hand. Another method is to sit in a swivel chair, point the laser at the wall outside of the bounding box and then turn in the chair so that the laser spot emulates a moving object in the FOV. That method tends to eliminate the dithering problem.

The purpose of the resolution entry is to tell the system what the camera is set to. You cannot use it to set the camera's resolution.

You may also want to reduce the initial zoom speed, for example, from 2.0 to 1.0.

Generally, the process to validate system operation is to:

1. Check operation with P/T and Zoom disabled and use the Default settings. Look for proper detection and tracking and adjust settings such as Crop, Blur, Delta, Min and Max areas if necessary.
2. Enable only P/T and check again. Look for proper detection, initial move and continuous tracking of the sort of targets that were detectable in step 1. Adjust camera Proportional constant larger if there is no hunting (unstable motion), then back it down a bit.

3. If that works, then enable Zoom. Look for the largest number of zoom-in increments without losing the target.

It would be best to try all this on daytime aircraft as test targets. At night, you may find that you want to make the Min area a bit larger to avoid triggering on twinkling stars.

For technical support feedback, the best sort of files to provide are just a Wide video plus a screenshot of your Wide and Camera configurations.

**Note the following:**

- The configured FPS should match whatever the camera is set to, which has various options depending on resolution. If they don't match that will affect two things: Displayed frame rates will be inaccurate; The length of recordings will not match actual times. It should not affect tracking.
- Pan/Tilt values are actual when a camera is a PTZ type. If not, then the P/T values are emulations based on the location of a detected target in the frame. Thus, if no target has been detected, then there are no PT values to change until then.
- Performance of the various Dahua cameras varies a bit depending on optical sensor sensitivity, P/T rate, etc.
- Older cameras such as the Dahua 50230, 50232 and 50A320 respond to ONVIF queries for position much slower than more current models (in about 450msec vs 30-60 msec). This creates problems when attempting to maintain control in a PID loop which uses the difference between current position and target location. This version of OTDAU attempts to improve on this by automatically incrementing pan, tilt and zoom values based on commanded velocity of those axes while setting the position values to actual any time they become available. That is, position increments are filled in during periods when they are not available from the camera itself. This augmented statusing is only applied to the cameras noted above.

## Camera Sharing

One IP camera may be used simultaneously by more than one copy of OTDAU. However, if more than one OTDAU attempts to send PTZ motion commands to that camera then both OTDAUs will react to motions created by any of them.

OTDAU provides a feature that prevents more than one copy of the software from controlling a particular IP camera. It does this by setting and reading a particular string of characters to the camera's On-Screen Display (OSD) as the "Channel Number". This text is initially "Available". If it was "" (blank) then OTDAU will initialize it to the Operator Name of the first PC that uses it. When a PC running OTDAU is set to the Run state, it reads and checks this text. If the text is "Available" or "" then it will set the text to its Operator Name. If the text is otherwise indicating that the camera is already in use, then it will perform all normal OTDAU functions for that configuration except for PTZ controls, if enabled. The position of this text on the video frame is preferred to be in the lower left so that in the Wide-Angle Display it is covered by text generated by OTDAU. It will be visible in the same position on the Auxiliary Video Display if that display is set to Raw Video.

A camera is initially set up for OTDAU sharing by setting the camera's OSD as shown in the following screen displays.

For a Sony camera, turn on Superimpose and edit its settings as shown below

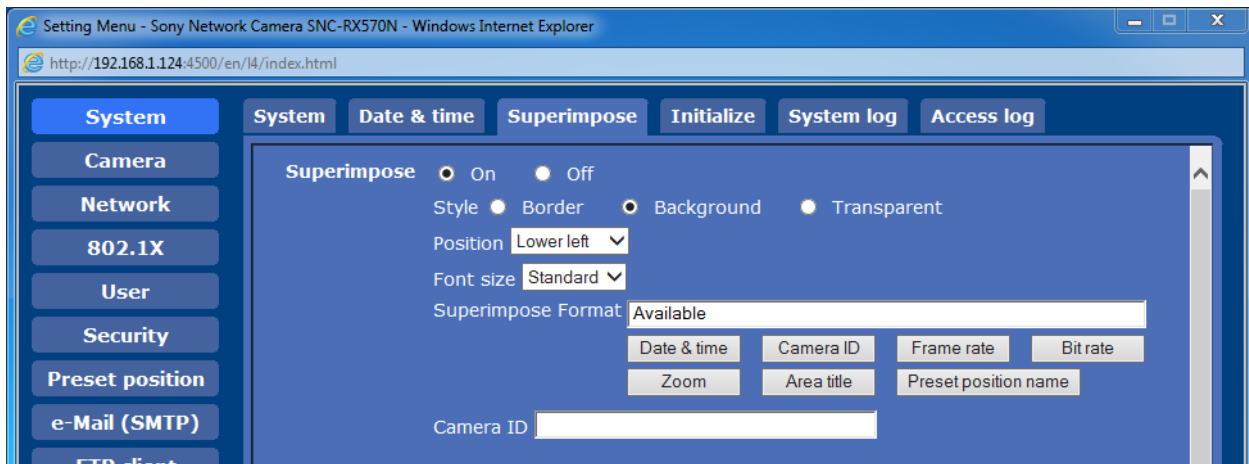

The resulting display will appear as follows:



Initially set a Dahua camera as shown below.

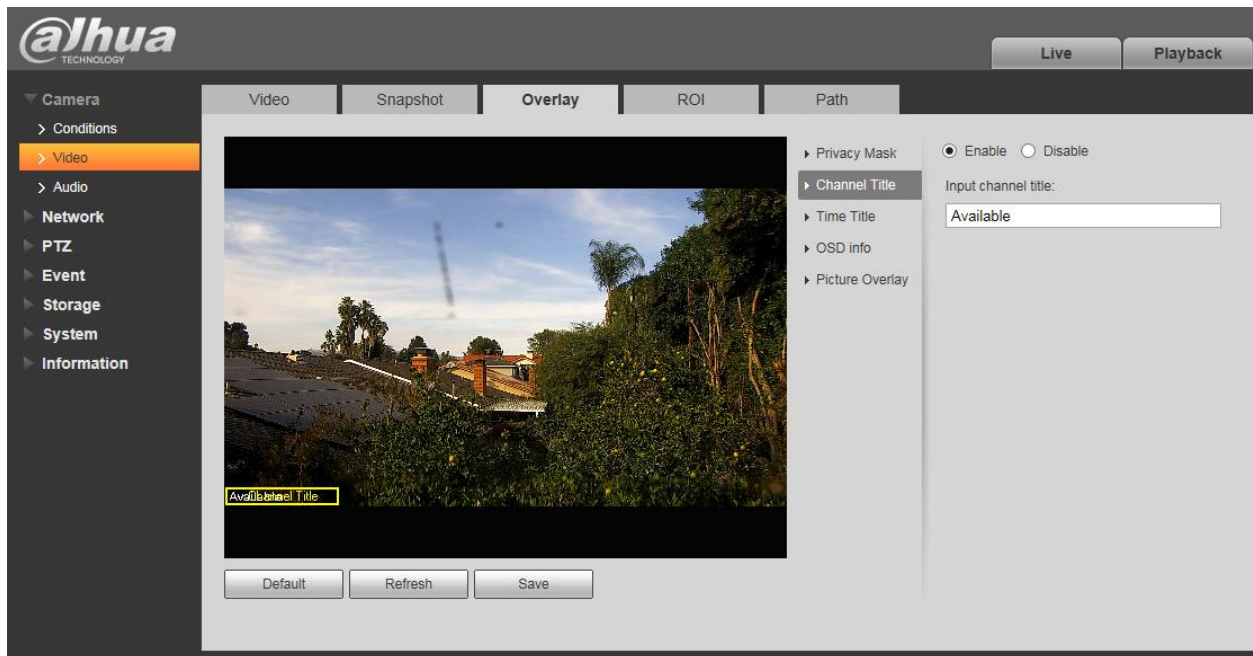

The resulting display will appear as shown below.

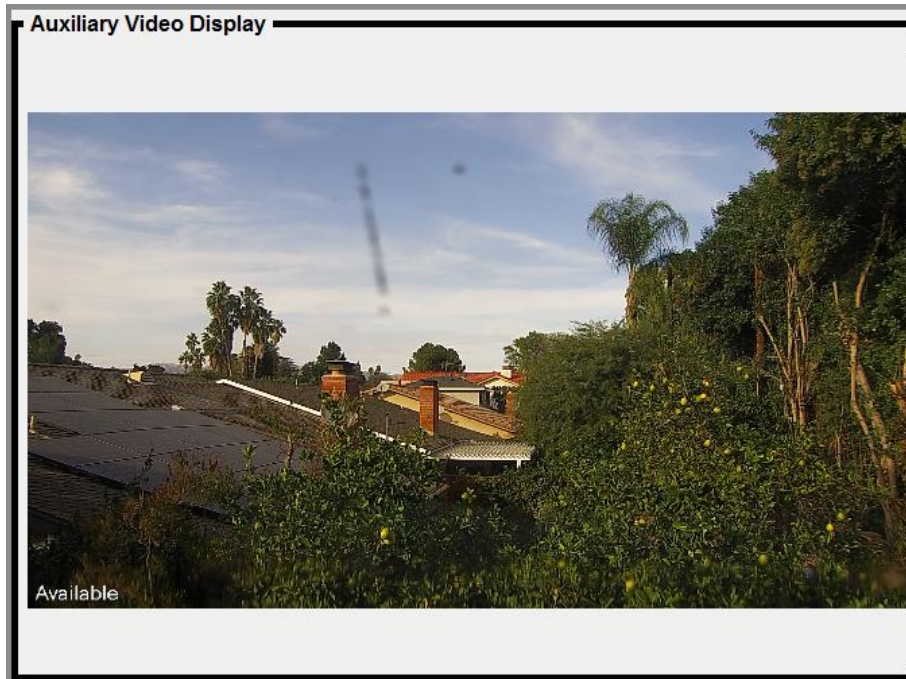

When a copy of OTDAU attempts to use a camera that is already in use by another copy of the software, then the second row of text on the Wide-Angle Display will indicate that the camera is in use and by what operator name takes the place of "Available" as the OSD. However, this indication is covered by metadata text, as shown below.

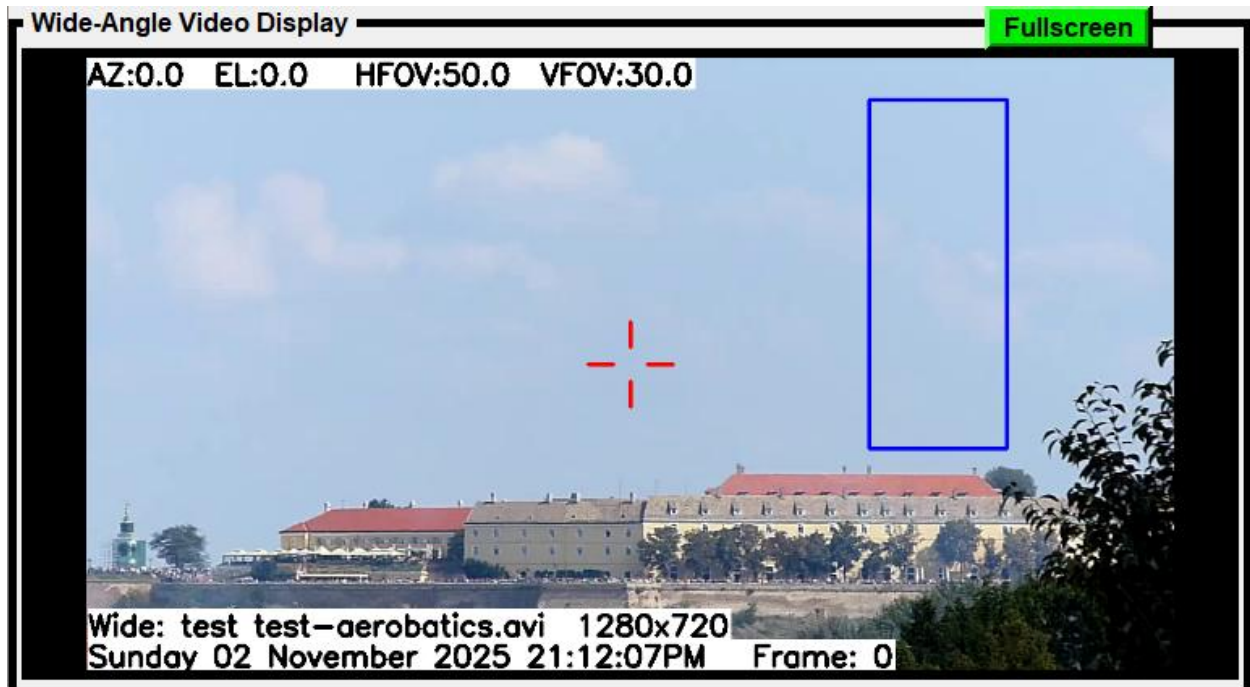

## Track and Zoom Tuning

After identifying an object for tracking, the OTDAU attempts to continuously move a PTZ camera such that the object is in the camera's CFOV. When the object image is within the Zoom distance (listed above) from the CFOV, both horizontally and vertically, then an increment of zoom is performed at the Zoom speed, for the Zoom time limit.

The method used to center the image is by means of a Proportional, Integral, Derivative (PID) feedback loop. The parameters used to tune this loop are listed above. Typically, one may only need to adjust the Proportional constant, leaving the other two at zero. If this constant is too large, then the system will move the object back and forth across the CFOV (assuming, just as a test case, that the object has very little movement). If the value is too low, then tracking will lag the target object movement such that the target will not be tracked at all. If the PID constants are not appropriately set, then zooming will also not provide acceptable results.

The best sequence to make these adjustments is as follows:

1. Disable Pan/Tilt and Zoom in your System configuration.
2. Provide tracking test targets. One way to do this is to use aircraft in your vicinity. Another more convenient method is to point the camera at a flat, light surface, such as an indoor wall, and use a laser pointer to simulate moving objects.
3. Select Run and verify that the system detects target motion. Setting the Auxiliary Display to Tracks helps visualize the rate and number of detections. Adjust the values of the Blur parameter and the Delta threshold to provide the highest rate of detections without false detections from background items.
4. Enable Pan/Tilt and repeat the tests and note the system response to moving test targets. Adjust the value of the Proportional constant until smooth tracking is achieved up to moderate target speeds.
5. Enable Zoom and adjusting the zoom-related constants so that a moving target is periodically and progressively zoomed into and not lost to tracking in the process.
6. If you were not using aircraft as test targets, set up your camera to do that and run the system to verify that tracking and zooming are operating as expected.

## Pan/tilt Positioner Configuration Options

OTDAU supports the use of remotely controlled Pan/Tilt heads that, unlike PTZ cameras, are independent of any specific payload, such as a camera. This feature allows use of a pan/tilt head that is not part of a PTZ camera so that any directional sensor, such as an IR camera, radar antenna or microphone could be pointed by an independent PTU.

As an example, see the System configuration “usb0-800x600-onvifptu”. This configuration uses the P/T portion of a 42212 camera and a USB camera for video. It emulates a system wherein a USB camera is mounted on a P/T unit. To do this, the Wide and Tele cameras are set to usb0-800x600, and the Pan/Tilt Unit is set to onvif-108. The Pan/Tilt configuration “onvif-108” references an ONVIF-compatible P/T unit that happens to be part of a 42212 camera (the video from the 42212 not being used). Ordinarily, the Pan/Tilt type would refer to a manufacturer’s part number of a PTU so that OTDAU would know how to control it. The Pan/Tilt Driver selection indicates that this PTU can be controlled with ONVIF commands.

OTDAU also includes a native Pelco-D driver, referred to as “ptuusb”. This driver may be used to control and status P/T Units that implement the standard Pelco-D protocol via ASCII serial over USB. See the PTU section of ufodap.com, for data sheets on compatible PTUs and the protocol implementation. If you obtain a PTU to use this feature, you will need a USB-RS422 converter and a digital PTU that properly implements absolute and continuous (velocity) moves as well as provides position feedback.

A new UFODAP PTU DAU is in development which will use a new driver and the IP address-related entries. Those entries are ignored by the ptuusb driver. The new driver will use the IP entries in place of the COM port entries. Both sets of entries will be available and used depending on which driver is selected.

Entry and selection of data to set up an optional Pan/Tilt head is as shown below.

OTDAU -- Optical Tracking Data Acquisition Unit Version 2.26 10-23-25

## Pan/Tilt Unit Configuration

Pan/Tilt type  Pan/Tilt Driver

Filename

Enable PT     Reverse absolute move     Reverse continuous move

To use the USB driver, enter the following USB Interface fields

COM Port  Baud Rate   
COM1 thru COM4    2400, 4800, 9600 or 19200

Data Bits  Stop Bits  Parity   
5-8    1 or 2    E, M, N, O or S

To use the IP driver, enter the following IP Interface fields

IP Address  HTTP Port  User  Password

Realtime data received from the PTDAU

Time  Satellites  Longitude  Latitude  Altitude

Proportional Constant

Integral constant  Derivative constant

**Pan/Tilt type** – Text description of the P/T configuration

**Filename** – (Display only) Shows the currently open filename.

**Enable PT** – Enables motion control commands from OTDAU, both manual and automatic, to control the PTU.

**Absolute move direction** -- Checked or unchecked depending on how the camera responds to absolute move commands. OTDAU issues an absolute move command upon confirming an initial target detection event. If a camera moves in the wrong direction upon testing detection, then reverse this setting.

**Continuous move direction** -- Checked or unchecked depending on how the camera responds to continuous move commands. OTDAU issues a continuous (velocity) move command after the absolute move stemming from an initial target detection event. If a camera moves in the wrong direction upon testing detection, then reverse this setting.

**COM Port** – Enter the COM port used by your RS422-USB serial interface.

**Baud Rate** -- Enter the serial baud rate used by your RS422-USB serial interface.

**Data Bits, Stop Bits, Parity** – Enter one of the allowed values as required by your RS422-USB serial interface.

**IP, HTTP Port, User, Password** – Data that defines the LAN connection to be used to communicate with this P/T head. Typically defined by data entered in the P/T head’s manufacturer-provided interface.

**Pan/Tilt Driver** – The software interface needed to communicate with this particular P/T head. Entry values should be either “ptudau” for PoE communication with the PTDAU or “ptuusb” for USB control of P/T motion.

**Proportional, Integral and Derivative constants** – Controls for the PID loop that attempts to minimize the error between the position of the target in the image and the center of the field of view.

### **Control buttons**

**Open** – Opens a window into the Pan/Tilt configuration file folder. Select a configuration by either double clicking on an entry or clicking an entry once and then click Open.

**Save** – Saves the current settings as part of the currently loaded Pan/Tilt configuration.

**Save As** – Opens a window into the Pan/Tilt configuration file folder. Saves the current settings as the Pan/Tilt configuration but with a new name selected in this window. It is very useful to Open an existing configuration, modify its values, and then Save As with a new name to create a new configuration.

**Close File** – Terminates view of the last selected configuration and clears all entries. This has no effect on any P/T units used in the currently open System configuration.

**Close window** – Closes the Camera Configuration window. If the window is closed before any changes to settings are Saved, then those changes are lost.

## Tracking Options

Select Tracking to adjust tracking settings. The values of the Default settings are shown below.

OTDAU -- Optical Tracking Data Acquisition Unit Version 2.24 3-1-24

### Tracking Settings

----- Definition of Terms -----  
Values determine how the tracking process detects and tracks valid motion  
Detection -- Potential target motion detected prior to a valid sequence  
Event -- A target detection after the detection validation period  
Sequence -- The set of events from validation until tracking termination  
Target event -- Target recognition occurs at this event, after Min time from first detection  
and results in the OBJECT DETECTED status message and start of recording  
All time values are in seconds

Min time -- Minimum time period of detections prior to tracking  
Sequence will be rejected if there are no detections for more than 1 second before this interval times out  
Higher values filter out short events such as birds or insects

Max time -- Maximum time after the first event before sequence termination and re-acquisition  
Limits the total tracking and recording time to this value  
Set to 0 for no time limit (Run until manual Stop)

Event interval -- Maximum acceptable time between events  
Provides time for dropouts in detections while tracking without loosing track  
Set to 0 for no timeout after target detection

Crop increment -- Relative size of new bounding box above target size  
Defaults to 4.0 if tracking by template matching

Blur -- Odd number of surrounding pixels averaged for each target image pixel

Delta threshold -- Sets minimum ON level for target image conversion to binary  
Detection effect can be visualized using Tracking Display

Min area -- Minimum allowed target size in pixels

Max area -- Maximum allowed target size in pixels

Note the distinction between potential target detections vs events. In OTDAU, a detection means that some motion was detected in a single video frame. An event is initiated when the characteristics of a series of detections indicate that a target of interest may be in view.

Units for time values are in seconds, and Blur is in pixels. Delta is grayscale value, from 0-255 (black to white) that is compared to each gray-scaled pixel of an image that is a frame-to-frame difference. Max and Min areas are square pixels. All time values are in seconds.

**Minimum time** – The minimum time of target detections to allow tracking of the sequence to begin.

Target tracking begins if motion is recognized after at least this period starting at the first detection. This filters out birds and other fast-moving objects. Tracking Settings allow Min time of 0 for fast targets, Max time of 0 for no limit to tracking/recording time and Event interval of 0 for no timeout after target detection. Use these alone or in conjunction with template matching feature for long-duration tracking of non- or slow-moving targets. **NOTE:** Default settings have been adjusted for better initial testing – Try the defaults first before modification for your situation. Use the Aux Display Telephoto option to see what was rejected, e.g., a still image captured of a bird.

**Maximum time** – The maximum clock time in seconds for a tracking event until the system returns to the Home position and restarts scanning for motion. It may be useful to limit this time if known obstructions may be encountered by a target, assuming its flight trajectory. It would make sense to increase this time to an estimated maximum event time.

The system uses the Minimum and Maximum area parameters (square pixels) to reduce some false positives by rejecting initial motion detections that are too small or too large.

After getting five such detections that are less than the Start Interval apart, It averages the size of each detection and then computes new max/min sizes to be used for the subsequent detections.

The new max/min values are the average +/- a value that is based on the video frame width and zoom value.

When the event sequence is over, the max/min reverts to the user-selected defaults.

**Event interval** – Maximum time in seconds between motion detections to declare the start of an event sequence. Adjust to filter infrequent detections, such as birds.

**Crop increment** – Relative number governing the amount that the crop or bounding box is reduced after initial target identification. This reduction is provided to reduce the possibility of distraction from trees, etc. as the object moves across the landscape. The larger initial bounding box is needed for initial capture over a wide FOV but is undesirable thereafter. The value reflects the size of the box above the size of the object during tracking. A typical initial value is 4.0 to 6.0. A larger value makes it easier for the tracker to capture a faster object given the latency of PT motion to move the object to CFOV after the initial motion recognition. Too large a value, however, will result in loss of lock for a larger distance from the object as it flies past background distractions. This value is automatically doubled for the first three events to better capture a target despite an inaccurate initial move. **NOTE:** The nominal value of this parameter should be set to 2.0 when Feature Tracking is enabled and a larger value when Handoff is used in dual camera configurations.

**Blur** – Must be a positive odd number. If an even number  $n$  is entered, then  $n+1$  is used. Filters background noise by averaging the surrounding  $n$  pixels around the central pixel. Larger numbers cause more filtering but lower resolution. For example, some cameras with low light sensitivity may show pixilated images in night conditions. If this parameter is too low, the camera will generate a lot of detections of the thermal noise in the video rather than actual objects. Increasing this parameter may allow such a camera to still be useful as it may ignore the noise but still recognize multi-pixel lights such as aircraft strobes. Thus, a larger number helps ignore video “noise”, clouds, etc. This is also helpful to allow use of cameras with poor low-light response that display thermal noise in low light conditions – noise is ignored and sufficiently large objects are still detected with a blur value of 5 or more. Setting this parameter too high will filter out valid objects.

**Delta threshold** – Threshold for moving object recognition with respect to a static background. Lower numbers increase sensitivity. Threshold for valid targets based on the difference from the prior frame average. Smaller numbers will allow smaller but perhaps less qualified images to be detected as targets. Nominal value is about 20 for typical uses. **TIP:** If you see a very large tracking box after initial target tracking, increase the Tracking Delta threshold to eliminate background noise and limit tracking to the desired target. Use the Aux Tracking display to visualize the effect.

**Min area** – The motion detection algorithm measures the contours of any “objects” sufficiently different from frame to frame. The area within these contours is tested to verify if it is too small to qualify as a valid target. If the system triggers on what seems like noise or objects that are smaller than what you expect to capture, such as cloud features, then increase this value. Use the Tracking option of the Auxiliary Video Display to visualize small differences that may be occurring, but the system is not triggering, as desired.

**Max area** – Maximum area of a contour allowed for a valid target. Decrease to reject objects that are too large, such as buildings or masses of dense foliage.

### **Control buttons**

**Save** – Saves the current settings as part of the currently loaded System configuration.

**Default settings** – Changes all settings values to recommended default values. Those values are shown in Tracking Settings view above.

**Close window** – Closes the Tracking Settings window. If the window is closed before any changes to settings are Saved, then those changes are lost.

**Tip:** Use the test System configurations, such as “test-aerobatics.json” to see what effect various combinations of Tracking parameters have on tracking performance.

You can also test a camera by pointing it at a blank wall and using a laser pointer to simulate a moving object.

Similarly, you can simulate various types of objects using the Setup > Display target simulator. The simulator adds a moving dot of selectable size color and speed to any video image. Thus, it works with both fixed and PTZ cameras and any other test videos.

Another way to find the best Tracking settings for a particular viewing environment is to use Manual recording to capture a typical target object, such as an aircraft, moving across the FOV. The resulting avi file can then be loaded via the System configuration “Open a video file for test” and played back as many times as needed. The resulting Tracking settings should then be a good starting point for actual live camera tracking.

## Touring Configuration

OTDAU has the capability to move a PTZ camera between up to 12 pan/tilt/zoom positions, in order, during a Run. The dwell time or duration of each stop can be set in hours, minutes, and seconds. Tracking object identification is suspended during moves between tour stops to prevent triggering on tour movement.

	Position			Duration			Set	Remove
	Pan	Tilt	Zoom	Hrs	Mins	Secs		
1	<input type="text"/>	<input type="text"/>	<input type="text"/>	<input type="text"/>	<input type="text"/>	<input type="text"/>	Set	Remove
2	<input type="text"/>	<input type="text"/>	<input type="text"/>	<input type="text"/>	<input type="text"/>	<input type="text"/>	Set	Remove
3	<input type="text"/>	<input type="text"/>	<input type="text"/>	<input type="text"/>	<input type="text"/>	<input type="text"/>	Set	Remove
4	<input type="text"/>	<input type="text"/>	<input type="text"/>	<input type="text"/>	<input type="text"/>	<input type="text"/>	Set	Remove
5	<input type="text"/>	<input type="text"/>	<input type="text"/>	<input type="text"/>	<input type="text"/>	<input type="text"/>	Set	Remove
6	<input type="text"/>	<input type="text"/>	<input type="text"/>	<input type="text"/>	<input type="text"/>	<input type="text"/>	Set	Remove
7	<input type="text"/>	<input type="text"/>	<input type="text"/>	<input type="text"/>	<input type="text"/>	<input type="text"/>	Set	Remove
8	<input type="text"/>	<input type="text"/>	<input type="text"/>	<input type="text"/>	<input type="text"/>	<input type="text"/>	Set	Remove
9	<input type="text"/>	<input type="text"/>	<input type="text"/>	<input type="text"/>	<input type="text"/>	<input type="text"/>	Set	Remove
10	<input type="text"/>	<input type="text"/>	<input type="text"/>	<input type="text"/>	<input type="text"/>	<input type="text"/>	Set	Remove
11	<input type="text"/>	<input type="text"/>	<input type="text"/>	<input type="text"/>	<input type="text"/>	<input type="text"/>	Set	Remove
12	<input type="text"/>	<input type="text"/>	<input type="text"/>	<input type="text"/>	<input type="text"/>	<input type="text"/>	Set	Remove

Disable tracking while at each position

**Description** – User-supplied description of the tour for reference.

**File name** – Desired folder and file name for saving a tour.

**Start tour** – Click to start running the tour if one has been loaded. This will have no effect if the camera is not a PTZ type or P/T is not enabled.

**Stop tour** – Stops running the tour and returns the camera to its home position.

**Disable tracking while at each position** -- PTZ enabled in System configuration is required to use Touring. Check this Disable tracking option to disable motion when tracking begins so that the PTZ camera can operate in a fast-tracking, fixed camera mode at each touring position.

**Loop mode** – Click ON / Click OFF: When enabled, the camera is moved to each defined position and then starts again at position 1.

**Open** – Opens a window to select a previously defined tour.

**Save** – Saves the tour values to the previously loaded named file.

**Save As** – Opens a window to select a new name for the tour configuration and saves it.

**Close Window** – Close the Tour Configuration window.

### **To set up a tour:**

Open a System configuration for the desired camera.

For each of up to twelve positions –

1. Move the camera to the desired position and zoom value.
2. Click Set to save those values into one of the positions.
3. Repeat move and Set for any other positions.
4. Enter the Duration for each position.
5. If different values are needed for a position, click Remove and set new values or leave blank – that position will not be used during the tour.

Click Save or Save As to save the tour position values.

Test the tour by clicking Start tour.

Click Stop tour at any time to abort tour movements.

Touring may be used with Pan/Tilt offsets to zero-out a PTZ camera home position.

**To use touring during a tracking run:**

1. Set up and save a tour as above or Open an existing tour.
2. Load a System configuration for the camera used to set up the tour.
3. Click Run to start the tracking process.
4. Click Start tour. Stop/Run and starting or stopping a tour can be set independently.
5. At any time, click Stop to stop the Run or Stop tour to continue Running but at a fixed position.
6. Clicking Loop mode will enable the tour to automatically restart at Position 1 and continue the tour after all positions have been moved to.

## Recording options

OTDAU -- Optical Tracking Data Acquisition Unit Version 2.26 10-23-25

### Recording Options

Disable recording  Enable recording  
Disable when OTDAU quits  Enable recording until manually disabled

Data path: D:\UFODAS DSLR

#### Primary Video and Data Options

Wide video with text  
 Wide and Tele frames Frame Interval: 0.0  
 PTZ data values to CSV file Data Interval: 1.0  
 Save a jpg of the digitally zoomed image of each detected but not tracked event

#### Auxiliary Video Options

Pre-detection recording time in seconds: 0.0

None  Automatically delete Path files with linear paths  
 Tele video without text  Tracking status  
 Tele video with text  Path of target detections  
 Wide video with digital zoom  Spectrum video and CSV of peak wavelengths at Data Interval

#### Audio Recording Options

None  
 Wide camera audio from RTSP stream or USB  Wide audio and video from RTSP stream or USB  
 Tele camera audio from RTSP stream or USB  Tele audio and video from RTSP stream or USB  
 Internal or external USB-connected microphone  
Channels (1 or 2): 1 Recording rate: 44100

#### DSLR Control Options

If mode dial is not set to movie:  
 Take one photo upon initial move to target and one each shutter interval  
If mode dial is set to movie:  
 Record video during tracking  
DSLR camera shutter release interval or maximum video recording time: 1.0

Save Close Window

### Primary Video and Data Options

**Disable recording** – Disables recording enabled by either of the following two selections.

**Enable recording – Disable when OTDAU quits** – Enables the recording selections to control data recording if checked. Defaults to disabled when the system is started to prevent accidental recording during the typical system startup. Startup may involve testing camera positioning, parameter tuning such as Tracking settings followed by rest Runs. This setting is retained through all changes to configurations or Run/Stop until OTDAU is shut down (Quit).

**Enable recording until manually disabled** – Enables recording but does not automatically disable when OTDAU quits. Recording is automatically reenabled whenever OTDAU starts. This option may be used with the AutoStart option to allow recording when OTDAU restarts.

**Wide video with text** -- Checkbox to enable recording of wide-angle camera video with overlaid data.

**Tele video with text** -- Checkbox to enable recording of Aux camera video with overlaid data.

**Wide and Tele frames** -- Checkbox to enable recording of individual wide-angle camera frames without overlaid data.

**Frame Interval** -- The number of frames per second at which wide-angle frames are recorded. For example, a value of 3.0 will record 3 frames per second. Decimating the data this way is particularly helpful to reducing the number of frames attached to a subsequent email to a number adequate to get a sense of the event. Later viewing the complete wide or telephoto video saved to the computer or uploaded to Google Drive will provide the entire captured video.

**PTZ data values to CSV file** -- Accumulate values of pan, tilt and zoom with associated time during an event and, at the end, write all values to a standard CSV (comma-delimited) ASCII file (name.csv). This file may be directly opened by Excel, for example, for graphing, data analysis, etc.

The format of the CSV file is a comma-separated list of values in seven columns. The first row contains the names of the data items:

Frame Time Pan Tilt Zoom TargetX TargetY

Each row thereafter is the values at each frame in which a target detection occurred, recorded at the Data Interval, below.

The Pan and Tilt values are in degrees and the Zoom value is the current optical zoom. The TargetX and Y values are the center of the target in pixels ranging from 0 to the horizontal and vertical size of the video frame.

**Data Interval** -- Interval in seconds between PTZ value recordings. For example, a value of 3.0 will record a set of PTZ values once every three seconds. If a target detection has not occurred within this interval, then the next recorded values will be at the next detection time.

**Save a jpg of the digitally zoomed image of each detected but not tracked event** – Provides a means to see a still image of what caused an initial detection but did not persist (meet the Min time requirement) to tracking. If Sound is enabled, each recording is accompanied by a higher-pitched tone.

---

## DSLR Control Options

OTDAU can control the shutter of any Canon camera that conforms to the latest CCAPI standard. New Recording option to release the shutter at any interval during tracking. Another option enables one snapshot following the initial move to a tracked target. Communication with the camera is via the camera's built-in WiFi capability. Also, configuration of various camera functions may be viewed on a new DSLR Configuration option in the Camera Configuration. Click on Open to view the camera's information and view its streaming image (with resolution reduced from the camera's maximum). Click Snapshot to take one photo. All photos are saved to the camera's local storage and not uploaded.

**DSLR camera shutter release interval** – If a compatible model of a Digital Single Lens Reflex (DSLR) camera is present (configured for WiFi use), and the Mode dial is not set to Movie, then a value greater than 0.0 sets the period between shutter releases (snapshots) during tracking. DSLR photos are saved to its local memory for later retrieval and not downloaded to OTDAU. Set the camera's rotary mode selector to A+ (or other selections, but not video).

### **Enable phot or video recording** –

If the camera Mode dial is set to anything except Movie, then when tracking starts, a snapshot will be taken immediately and at the DSLR camera shutter release interval until tracking stops.

If the camera Mode dial is set to Movie, then when tracking starts, video will start to be recorded. Recording will stop when tracking ends.

Selecting this option causes the camera to stream video frames to its internal memory as configured by camera settings. If enabled, then only video will be recorded with no shutter release functions.

**NOTE:** The current version of OTDAU does not support using a DSLR for remote shutter/video control at the same time as a System configuration that uses two other cameras. A three-camera configuration may be supported in future versions.

IP camera writes do not skip frames due to the write loop being slower than the frame rate because frames are queued for writing. If the time it takes to write a frame to disk exceeds the frame rate, then the queue will eventually be full resulting in dropped frames. A warning Status line indicates that condition. The write time depends on the frame size and the write speed of your computer. To test this issue, start Manual recording by selecting Ready to Record and check the track queue messages to ensure the queue length does not continuously increase beyond its limit. If so, reduce the camera frame rate or resolution. Be sure these are also changed in the Camera configuration. Some examples by camera of maximum frame rates for a given frame size and rate on my system (your results may vary) for no frame drops:

NK8BR4, 4000x3000 (12MP) set to 25FPS: 21 FPS

NK8BR4, 2880x2880 (8MP) set to 30FPS: 30 FPS

N65CL5Z, 3072x1728 (5MP) set to 25FPS: 25 FPS

42212, 1920x1080 (2MP) set to 30FPS: 30 FPS

Note that all Wide and Tele images now include the UFODAP logo in the lower right corner. The size of the logo is scaled to the resolution of the camera.

---

## Auxiliary Video Options

**None** – Click to select no Auxiliary recording.

**Wide video without text / Tele video without text if in Handoff mode** -- Click to record the Wide video stream without any overlaid meta-data. Records the Tele video stream if Handoff is enabled.

**Wide video with digital zoom** -- Click to enable recording of telephoto (digitally zoomed and stabilized) camera video with overlaid data.

**Tracking status** -- Click to record the Tracking view of the Auxiliary Video Display.

**Path of target hits** -- Click to record the Wide video stream with overlaid sequence of track boxes indicating all the detections during the Run. If Path analysis detects a non-linear path, the file name path will be appended with “-NLP”.

**Spectrum** – Record video of the generated optical spectrum if that feature is enabled and operational.

**Pre-detection recording time in seconds** – Specify up to five seconds of camera video prior to a target event to be included in a recording. OTDAU continuously saves video frames in a circular buffer prior to an event. This feature only applies to Auxiliary video selections. The slider control is adjustable from 0.0 to 5.0 seconds to set the period of the selected Auxiliary video source, prior to the start of a tracking event, to be recorded along with video starting at start of the event. Source data is continuously saved in a circular buffer, and the requested length is appended to the beginning of the output file when the tracking sequence is over.

**NOTE:** The System and Camera configuration files used for the recorded tracking session are also recorded at the Group level, defined below.

The run time for any Aux file will be the sum of the Wide camera recording time plus the Pre-detection time +/- 1 second.

---

## Audio Recording Options

OTDAU can record audio as a .wav file derived from an RTSP camera stream, from a USB camera or from a microphone interfaced to the computer. It can also combine that audio with the camera's video frames and record an .avi file. Audio encoded into an RTSP stream might come from a microphone built into the camera or from a cable to the camera.

In addition to the Primary and Auxiliary Options, you can record audio during a tracking event (or manually). Recording may be from an IP camera with a microphone or from a USB mic or webcam mic. Recordings may be audio alone, resulting in a .mp4 file or combined with video resulting in an .avi file. Number of channels may be selected as well as the audio recording bit rate. Standard rates are: 8, 16, 24, 32, 40, 48, 64, 80, 96, 112, 128, 160, 192, 224, 256, or 320 (add a k after each to get that rate). Any value in this range will work but will be truncated to the closest 1KHz. For your particular computer, if you check the actual file bit rate (using file > Properties > Details) the maximum rate might lower, such as 48kbps even if a higher rate was selected. Note that AV (avi) files are about 3 seconds longer than the tracking period to record the full period audio.

**None** – No audio or A/V will be recorded.

**Channels (1 or 2)** – Number of audio channels recorded: 1 (mono) or 2 (stereo).

**Recording rate** – Audio recording bit rate, typically 44,100 bits per second. Enter a value without a ','.

Select one of the following five options:

- **Wide camera audio from RTSP stream or USB**
- **Wide audio and video from RTSP stream or USB**
- **Tele camera audio from RTSP stream or USB**
- **Tele audio and video from RTSP stream or USB**
- **USB- or PC-connected microphone**

---

## Data path

Enter the disk drive path where the system will create a folder that will contain any video or image files collected during run time, as selected above. At the time data is written, the folder will be created if it does not exist.

The path format is: <drive letter>:\<name>

For example: D:\UFODAS Data

The name must be in Windows standard format and may be anything the user finds descriptive, composed of upper and lowercase letters, numbers and special characters not including:

- < (less than)
- > (greater than)
- : (colon - sometimes works, but is actually NTFS Alternate Data Streams)
- " (double quote)
- / (forward slash)
- \ (backslash)
- | (vertical bar or pipe)
- ? (question mark)
- \* (asterisk)

The following filenames are reserved and cannot be used:

CON, PRN, AUX, NUL  
COM1, COM2, COM3, COM4, COM5, COM6, COM7, COM8, COM9  
LPT1, LPT2, LPT3, LPT4, LPT5, LPT6, LPT7, LPT8, LPT9

Also, filenames cannot end in a space or dot.

**Note** that if recording is Enabled, and no other selections are made, the minimum that will be recorded is raw video, namely, the Wide camera view without overlaid metadata.

## **Control buttons**

**Save** – Saves the current settings as part of the currently loaded System configuration.

**Close window** – Closes the Recording Options window. If the window is closed before any changes to settings are Saved, then those changes are lost.

---

## Log File

A log file is opened in the Group folder when the folder is initially created. The file name format is “otdau-logfile-<date>\_<time>.txt”. Various messages are written to the log during Run time that may be useful for debugging or data analysis. The file is closed at manual Stop. More types of messages may be added for logging in the future.

## Data Analytics Options

The Analytics tab selects two sets of data analysis tools:

- Object Identification
- Spectral Analysis

### Object Identification

Object Identification provides the following real-time and offline tools:

The screenshot shows the OTDAU software interface. The title bar reads "OTDAU -- Optical Tracking Data Acquisition Unit Version 2.28 6-9-26". The main window title is "Target Identification and Data Playback Options". The interface includes several checkboxes for enabling various analysis tools: "Enable analysis, real-time or batch", "Enable modification of folder names to include ID", "Enable YOLO day/night object identifier (slower than SSD)", "Enable Single Shot Detector (SSD) daytime Object identifier", "Abort detection if YOLO or SSD recognize foliage", and "Enable Nighttime Aircraft Identifier (NAI)". There is also an unchecked checkbox for "Enable end of file analysis if confidence exceeds threshold". Below these are two input fields: "Threshold confidence percent" with a value of 50.0 and "Maximum frame for analysis or playback (blank for all):" with a value of 100. A "Data path" field contains "D:/UFODAS 49425". At the bottom, there are several blue buttons: "Select folder", "Select file", "Save options", "Stop", "Close Window", "Start", "Pause", "Continue", "Step frame >", "Step frame <", and "Next file".

OTDAU includes tools for online and offline analysis of collected data. Typically, a long data collection run will record many event sequences triggered by mundane targets, such as aircraft and birds. Manual analysis of those events requires opening each Group folder and playing at least one recorded file for the event, looking for true unknowns. That can take a long time if many events are recorded.

OTDAU Data Analytics can greatly reduce the time to analyze collected data by automating recognition of known target objects in collected data. It utilizes advanced methods of machine vision and deep learning technologies to scan all files under a user-selected folder, determining the most likely initial target object in each and then modifying the associated folder name to include its identification and confidence

measure. The user can then focus further analysis on files labeled UNKNOWN or those with low confidence. The identification process may be run online, following each target event or offline, for a batch of events under a single folder.

OTDAU supports reading and streaming all the following file types for A/V files: avi, mp4, mov, flv, wmv and mts (AVCHD).

Currently, objects that the software attempts to recognize include:

In daytime lighting conditions --

- Aircraft of all types as well as helicopters
- Birds in many modes of flight
- Foliage such as trees

In nighttime conditions –

- Aircraft with standard blinking navigation lighting

**Note:** Since the analytics functions do not know the user-specified bounding box at the time the recording was made or how it changed during tracking, a bounding box that initially includes most of the frame is assumed when analysis of a file is started. Analytics detects the target object by methods like those used by OTDAU when the target was originally detected and recorded. It reduces the bounding box after initial detection to a value most useful to the recognition functions. Under some conditions, the box may be returned to maximum size until another detection of a moving object is found.

Somewhat more accurate and faster recognition may be obtained by enabling recording of CSV files during OTDAU data collection. This is because analytics will use such a file, if it finds one associated with the video data, to only locate and bound the target according to the TargetX and TargetY values in the CSV file instead of examining every frame.

All Analytics options are saved in C:\OTDAU\AnalyticsOptions. Options are saved when the “Save options” button is clicked and are read and displayed when Analytics is subsequently opened.

**Enable analysis, real-time or batch**– Enables analysis of a target data collection sequence both during tracking and immediately after collection has completed, Recording has been selected and the associated, new video and data files have closed. Enabling this option will delay automatic scanning for another event while analysis is in progress. If enabled, a thumbnail video of the tracked target with the current identification will appear in the upper right corner of the Wide-Angle Video Display. **Do not Start Analysis after this selection – just checking this box will cause auto-analysis after each detection/tracking and recording interval after Run is activated.**

An example of real-time analysis:

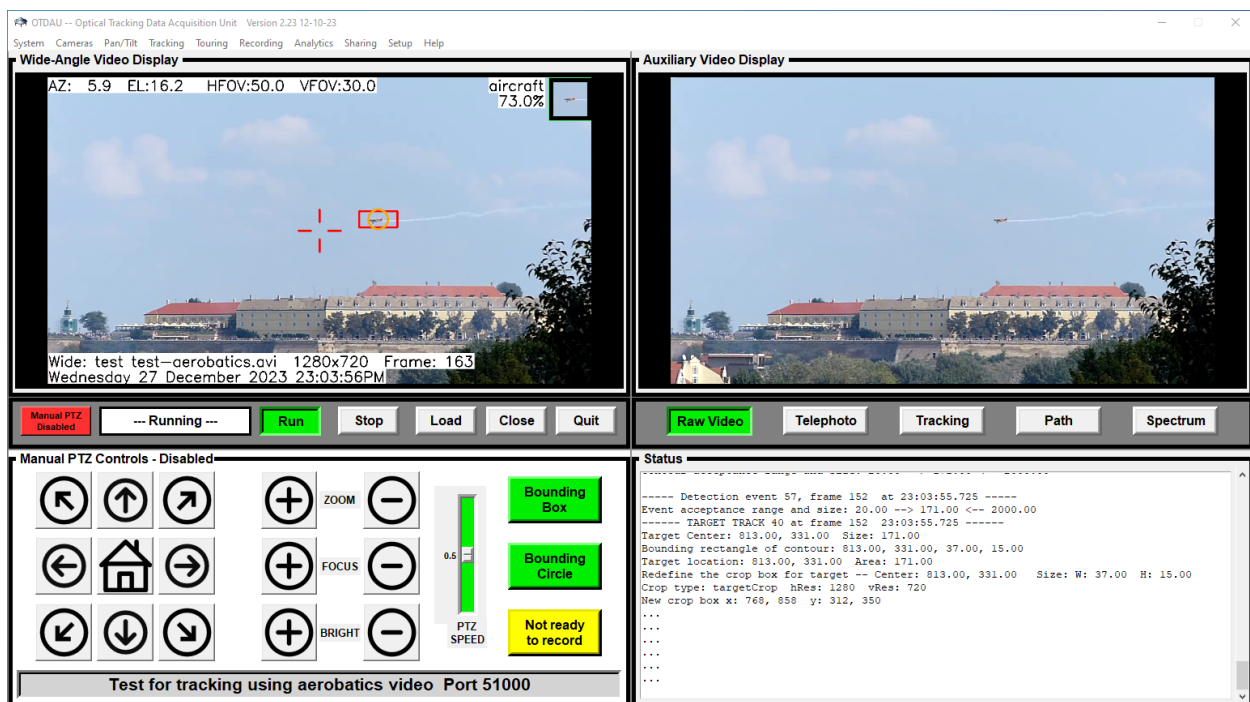

**Enable modification of folder names to include ID** – Enable modification of analyzed folder names to include the ID and confidence determined for the collection of files in that folder. After tracking, when data is written to the designated folders, the folder name containing video data will be renamed with identifying information added to the folder name in the form “...ID-name-confidence%”. For example, “dahua-49425-130-1920x1080-02-20-26\_09-16-19-44\_ID-aircraft-99.93%”. The ID could be aircraft, bird, foliage or UNKNOWN. If at least 10 tracking events are detected during the run, then the ID will be “ID-NONE”. The path indicator “NLP” may also be added indicating that path analysis detected a non-linear path.

**Enable YOLO day/night object identifier (slower than SSD)** – Enables a “You Only Look Once” deep learning identifier. The YOLO recognizer supports both v3 and v4 model weights. The version is selectable at runtime; v4 remains the default. GPU Acceleration for YOLO (Where Available) The packaged build now automatically bundles CUDA runtime libraries if they are present on the build machine, enabling GPU-accelerated YOLO inference on systems with an NVIDIA GPU. CPU-only operations are unchanged on machines without CUDA.

**Enable Single Shot Detector (SSD) daytime Object identifier** – Enables “Single Shot Detector” identification method. Depending on scene content, it operates up to about 80% of the real-time frame rate. Best for daytime lighting conditions but can be enabled for low light conditions. Can detect birds and various types of aircraft.

**Abort detection if YOLO or SSD recognize foliage** -- Aborts tracking if foliage is identified to minimize time spent hunting without a target.

**Enable nighttime aircraft identifier** – Enables an alternate method of aircraft identification in nighttime lighting conditions. Can be enabled for any set of day or night files and will automatically be engaged for videos with low light. May be enabled for all lighting conditions but may not identify aircraft lights in daylight. The NAI confidence formula uses rate score (how close to ideal aircraft strobe rate) combined with cycle count score.

**Enable termination of file analysis if confidence exceeds threshold** -- Enable a time-saving method of terminating analysis of a file if the identification confidence is greater than the percent entered. If more than one identification method is enabled, then any of them that exceed this value will terminate analysis.

**Threshold confidence percent:** -- Minimum percent confidence level required to label a file as identified.

**Maximum frame for analysis or playback (blank for all)** – Enter the maximum frame number as a limit to the number of frames that will be played back for review or identification. If the field is blank, then all frames in a file will be played.

**Data path <path name>** -- The name of the path and, optionally, the file to be analyzed. If no file name is selected, then the software will search for and analyze any files it finds, even if in sub-folders, below this named folder.

File names that are analyzed have the following elements in their filename:

Start with “otdau-aux” or “otdau-tele” and end with “.avi”

**Maximum frame for analysis or playback (blank for all)** – Analysis will be performed on all input frames up to this value and then stop. If no identifier is selected, then the video file is simply played back for visual review. If this value is 0 or blank, then all available frames are played or analyzed.

## **Control buttons**

Click on the seven buttons at the bottom of the Options display to perform an analysis as follows:

**Select Folder** – Opens a Browse for Folder window. Click on any folder that contains collected data (or has a folder below it that contains the data) and then click OK. When your selection has been completed, the complete path to the selected folder will be shown in the Data Path box. If a non-existent folder is selected, the browser will start at the top, Desktop level. You can browse to any folder from this level.

**Select file** – Opens a window showing all of the files under the folder in the selected Data Path. Double click (or click and then Open) one of these files to analyze that file only. If the window contains a folder, you may double-click it to open the files or folders it contains, ultimately selecting the file you want. When your selection has been completed, the complete path to the selected file will be shown in the Data Path box.

**Save options** – Saves all analysis selections in the file:  
“C:\OTDAU\AnalyticsConfig.txt”.

**Stop** – Stop all processing. After selecting this option, Pause and Continue have no effect. Selecting Perform analysis will restart all processing. If any folder names were modified due to prior analysis, then they will be changed again to conform with any new analysis results.

**Close Window** – Closes the Analytics Options window. The selection shown in the Data Path box is saved in the AnalyticsConfig.txt file.

**Start** – Starts the analysis process by opening the folder and file (if any selected) designated in the Data Path box. If only a folder specified, then the tree of sub-folders below it will be traversed to find any .avi files to analyze. The functions specified in the check boxes described above will be enabled during the analysis. The most likely reason for misidentification or low confidence is that the target object was too small for the identifier to recognize.

**Pause** – Pause reading and processing frames from the currently open video file.

**Continue** – Continue processing video frames from the point at which processing was paused.

**Step frame >** -- Click to advance the display to the next frame. Can be the first action after selecting a data folder or file or, when a file is running, it will stop playback at the current frame and then may be used to advance frames one at a time.

**Step frame <** -- Click to advance the display to the prior frame. When a file is running, it will stop playback at the current frame and then may be used to view past frames one at a time. When using Step < (back) and the frame number reaches 0, then frame numbers will start to decrease beginning at the number of frames in the file.

**Next file** – Aborts playback of a file in the selected folder and starts playback of the next available file in that folder.

Some examples of file selection and analysis are shown below.

SSD analysis and termination upon >50% confidence enabled. The maximum frame number that will be played is 200. The Data path is specified was either typed in or was retrieved from analytics\_config.txt when Analytics Options was selected:

You can use SSD to identify foliage in analytics and then, as an option, enable restart of tracking if foliage is recognized. This may be a better option than only using a bounding box to eliminate foliage – If a tracked target flies into foliage, the original target may be quickly reacquired, and tracking continue instead of the foliage becoming the tracking focus. This may be especially useful when using a fixed camera with a bounding box so that it is not necessary to enable the option to confine tracking to the box area only. Tracking may continue until the target gets to foliage without trapping tracking there. Without this option, clutter detection may also terminate tracking. (**Note** that YOLO detection of foliage may also work but since the YOLO foliage category was trained on potted plants, it may not be very useful for this purpose.)

Clicking on Select data folder opens a folder browsing window:

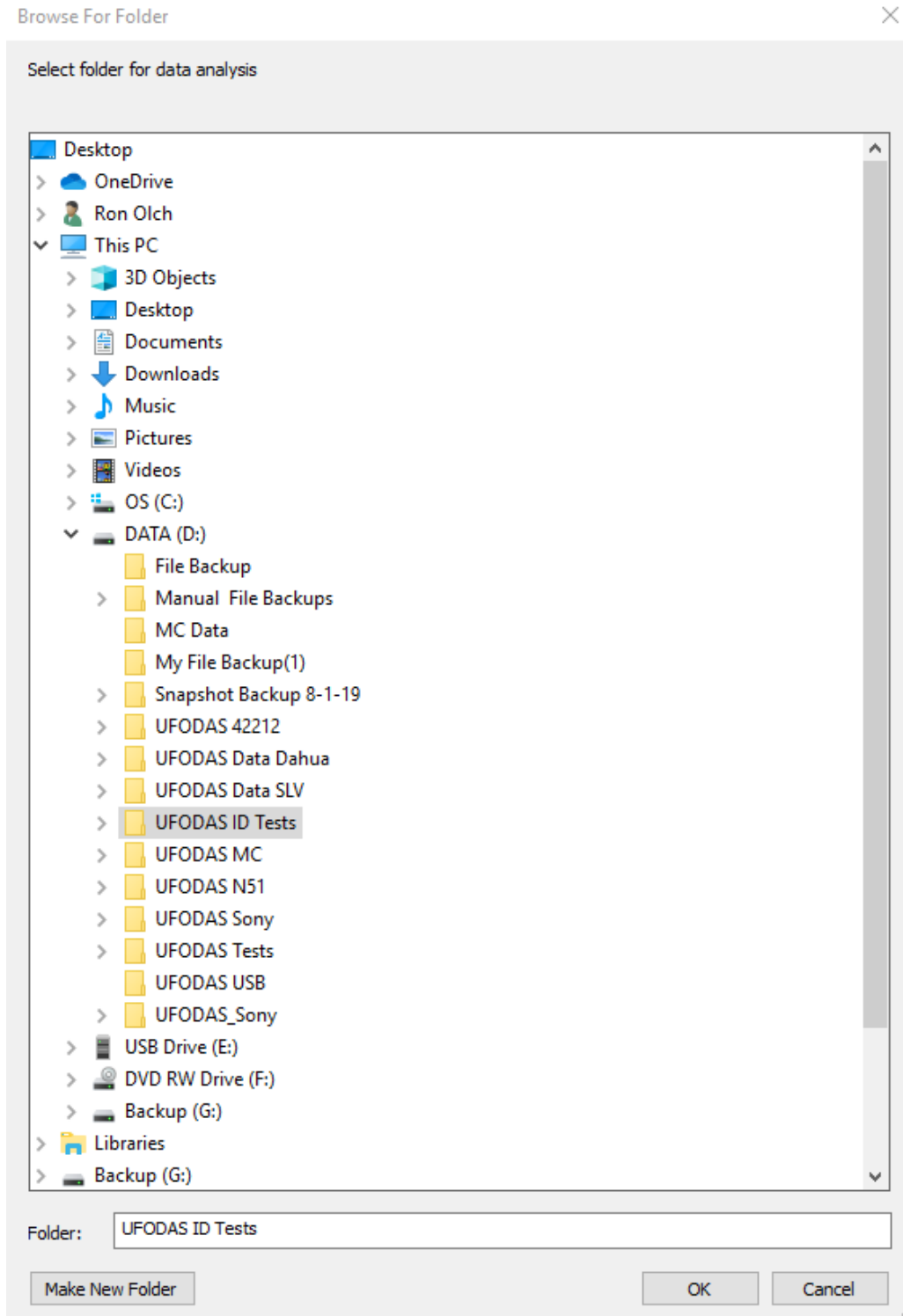

A fragment of the window above is shown below after “UFODAS ID Tests” was clicked, exposing the folder “test-aerobatics-12-09-19\_17-23-31” below it:

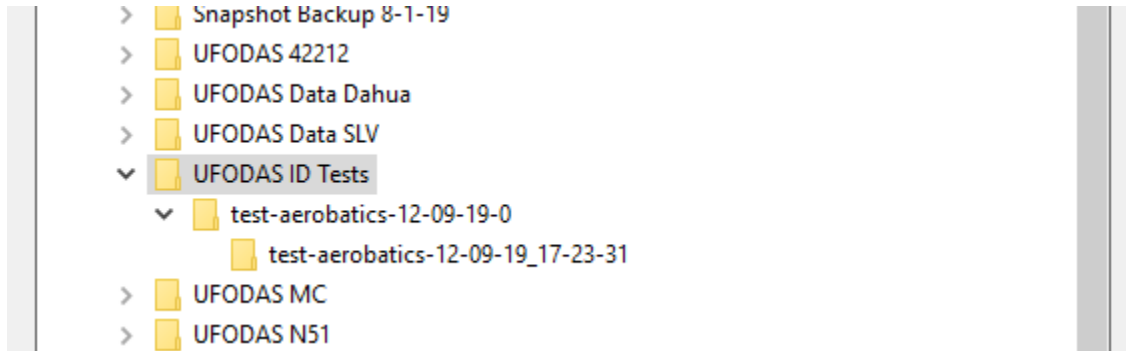

After selecting the test-aerobatics folder, its path populates the Data path field:

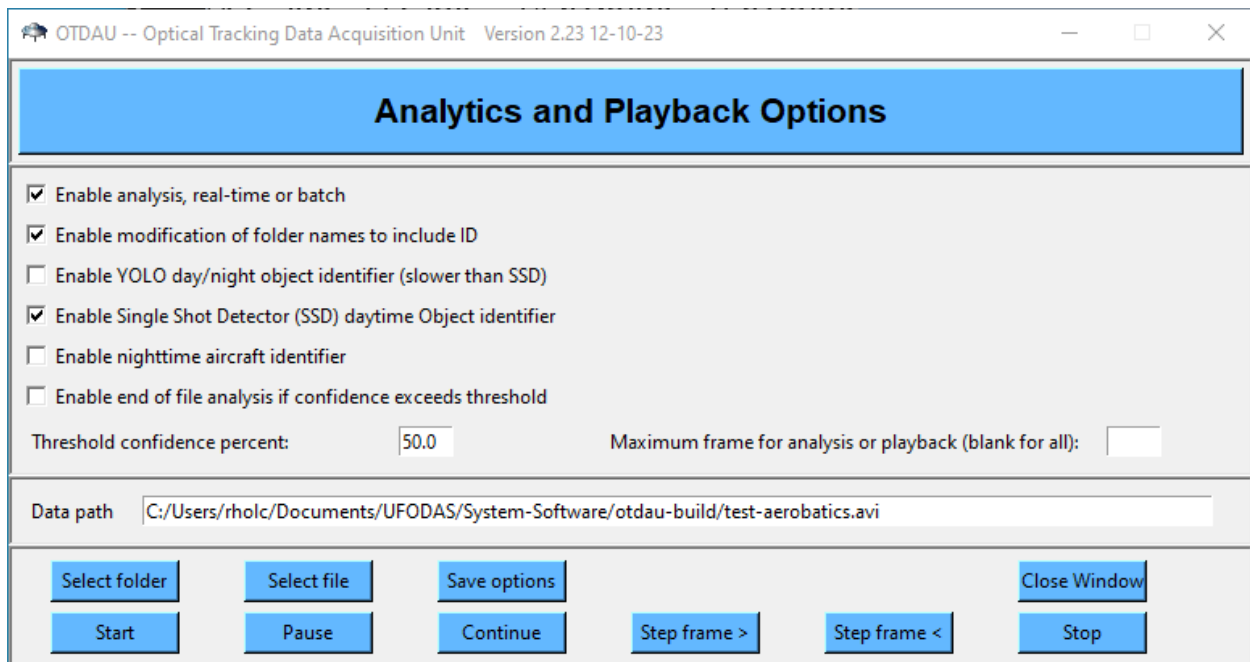

This fragment shows the files contained in the selected analysis folder:

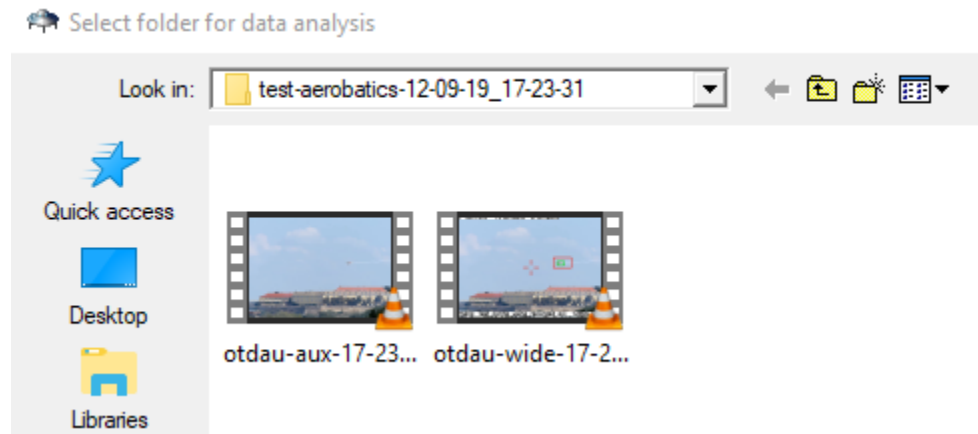

Now, when Perform analysis is selected, the file “otdau-aux-17-23-31 is read and analyzed frame-by-frame with the result that the aircraft is correctly identified to a confidence level of 98.08%. Analysis has been Paused to obtain the snapshot shown below:

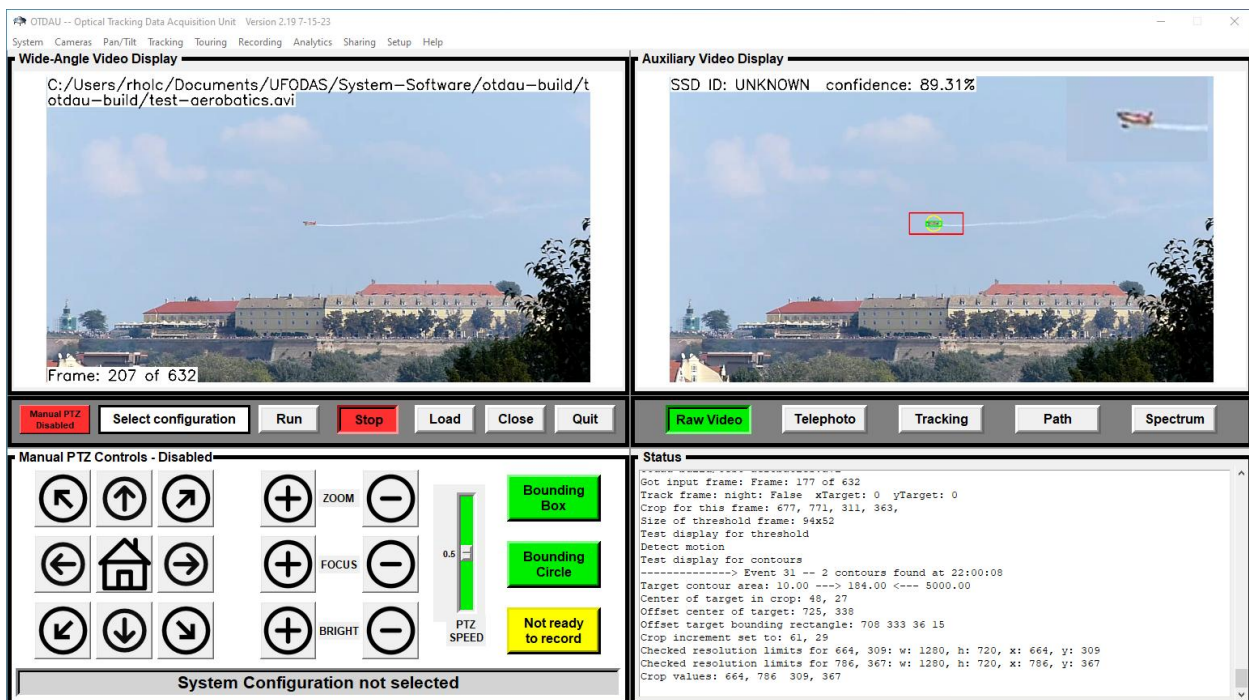

Note that if the folder “test-aerobatics-12-9-19\_0 had been selected instead, any video files in folders below it would have been analyzed. The example above only shows one folder below, but there could be many – one for each target acquisition during a run.

If the other analysis option, nighttime, were also selected prior to analysis, then a separate line for each would be added to the top of the right-side display along with the SSD result.

The Frame similarity value on the bottom of that display indicates the similarity of this frame to the last using the SSIM (Similarity Index) method. Since the initial bounding box used when the video data was originally captured is not known, this process is employed to determine if “motion” in the frame was due to actual target motion or camera motion and, if the latter, is rejected. Thus, the identification analysis methods are more likely to be applied to the actual target that caused the recording to have been made.

Note that during analysis, the software automatically selects and moves the bounding box. Since the box could be anywhere in a collection of analyzed files and because the analysis process is automated, it would not make sense for the user to try to set it for every file.

## Spectral Analysis

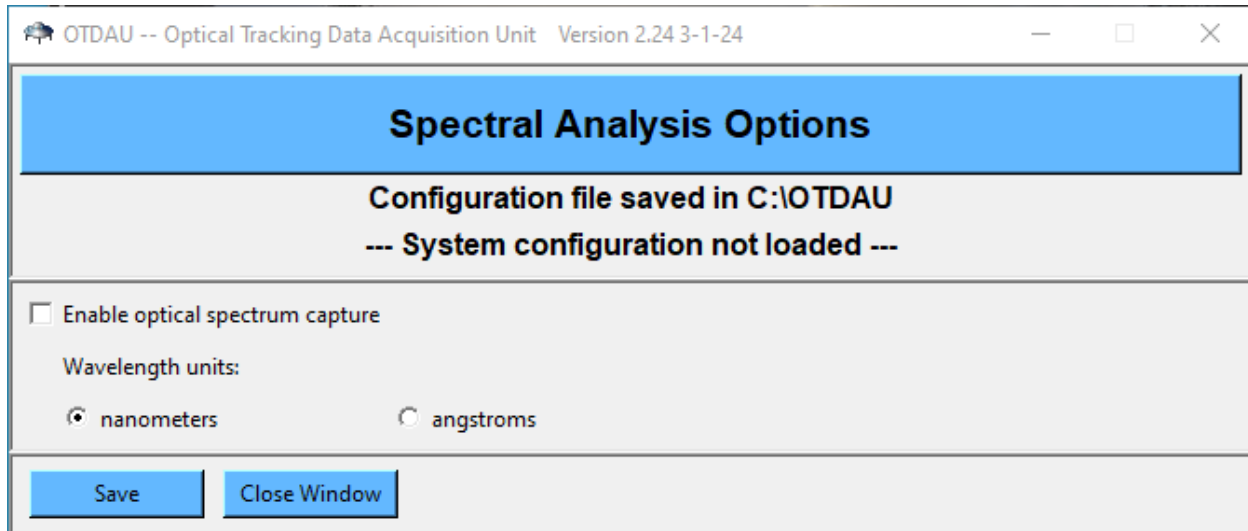

**Enable optical spectrum capture** – Enables automatic location of the line spectrum generated by use of a transmissive optical grating mounted in front of the camera lens. The located spectral line is then used to create an optical power spectrum plot (relative power vs wavelength) that may be viewed using the Spectrum button or optionally recorded. This option allows the real-time, continuous spectrum of light from a tracked object to be recorded for later analysis.

**Wavelength units** – Selected how the spectrum plot and recorded CSV file represent and label wavelength data.

### **Control buttons**

**Save** – Saves the current settings for use during the next Run period.

**Close window** – Closes the Setup Options window. If the window is closed before any changes to settings are Saved, then those changes are lost.

To use the optical spectrum feature, a blazed grating must be mounted in front of your camera lens. The grating must be rotated so that the spectral line resulting from a point-like light source is horizontal and on the left of the point.

For spectrum generation, go to the new Spectral Analysis menu, enable spectrum capture, and select nanometers or angstroms for the wavelength unit display. Running the System configuration will cause continuous spectrum capture and plot generation.

Select Spectrum for the Auxiliary Video Display to see spectrum plots. You can record both a video of that display as well as a CSV table of peak wavelength/intensity values via the Spectrum selection in the Recording Options menu. The time between recorded sets of peaks is governed by the Data Interval setting.

If the Spectrum function has been enabled but tracking is not running yet, a sample spectrum of a neon lamp is displayed:

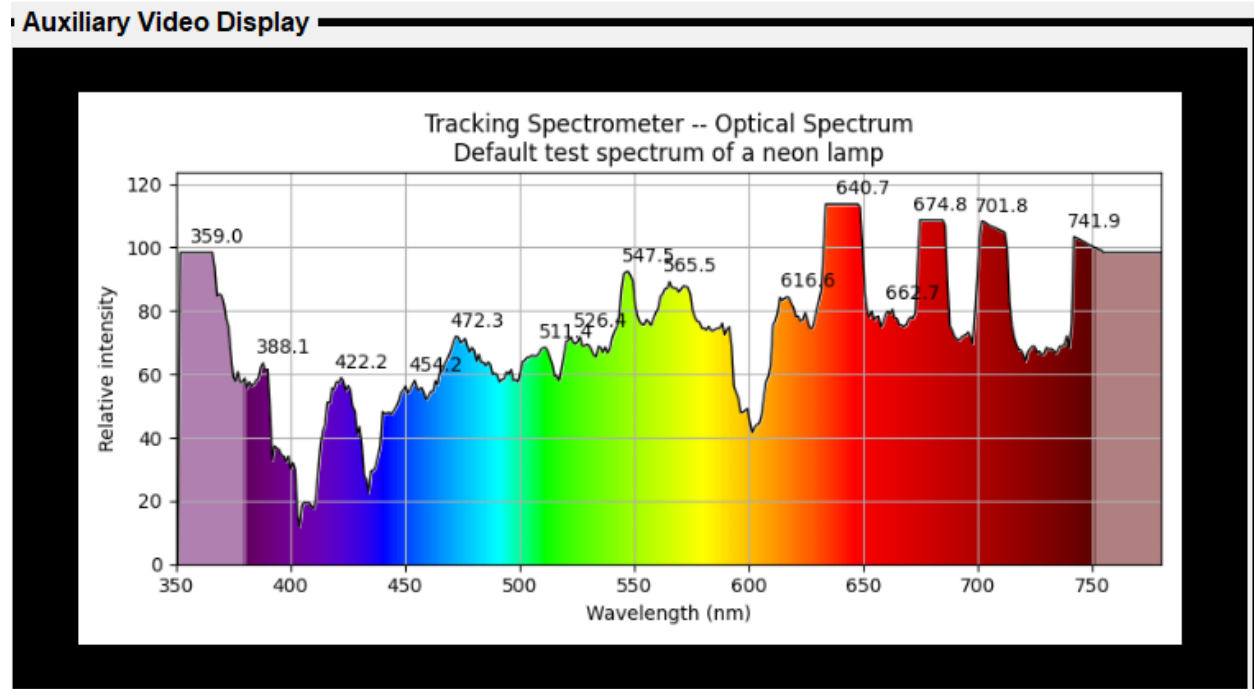

As a means of aiding spectrometer testing and calibration, if a System configuration is loaded and spectral analysis is enabled but not Running, then the spectrum is measured about once/second with the assumption that the target is at the Center Field of View (CFOV) and the Spectrum display will be updated with the results. When the system is Run, measurement and display occur whenever a target is detected.

Also, the line spectrum used to compute the graph is shown in a thumbnail in the upper right corner of the Wide display.

### Send Email

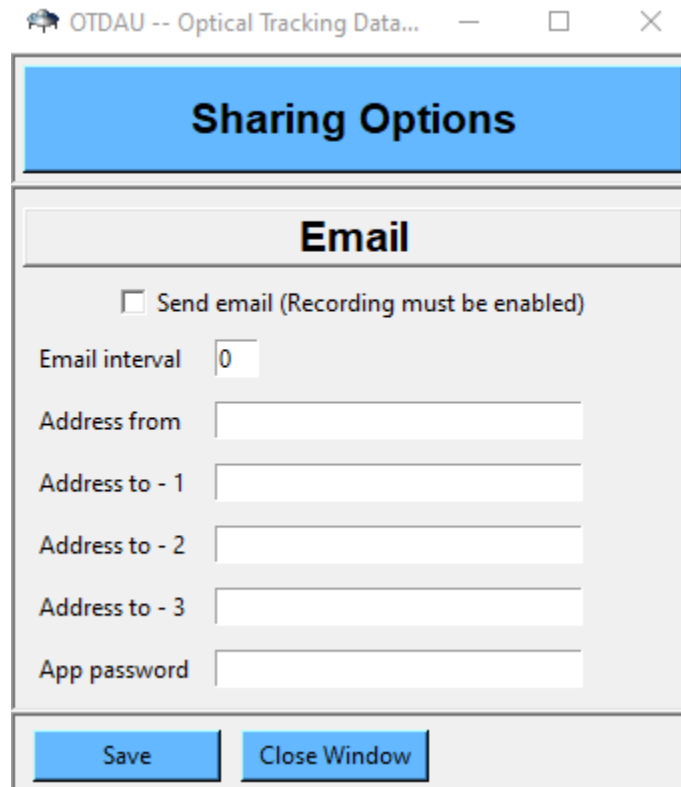

The screenshot shows a window titled "OTDAU -- Optical Tracking Data..." with a blue header "Sharing Options". Below the header is a grey section titled "Email". Inside the "Email" section, there is a checkbox labeled "Send email (Recording must be enabled)". Below the checkbox is an "Email interval" input field with the value "0". There are three "Address to" input fields labeled "Address to - 1", "Address to - 2", and "Address to - 3". At the bottom of the "Email" section is an "App password" input field. Below the "Email" section are two buttons: "Save" and "Close Window".

Checking the **Send Email** checkbox will cause the system to send an email including all recorded video and still frame files as well as the current System configuration JSON file for reference.

**Email interval** – The minimum time in seconds between possible email transmissions. This is used to avoid too many emails when target conditions result in many rapid sequential identifications.

**Address from'** – Your email address, for example: johndoe@gmail.com.

**Address to – 1, 2, 3'** -- Up to three email addresses that you would like the system to send emails to. A copy of the same email will be sent to each address.

**App password'** -- The application-specific password associated with the named Gmail account. **This is not the Gmail password you use for access to emails via gmail.com.**

### **Control buttons**

**Save** – Saves the current settings for use during the next Run period.

**Close window** – Closes the Setup Options window. If the window is closed before any changes to settings are Saved, then those changes are lost.

You can generate an app password by the following process:

<https://support.google.com/accounts/answer/185833?hl=en>

Start by navigating to your Google Account via the hyperlink in the above page. Follow the process to “Create & use App Passwords”. When asked to select an app, enter OTDAU and then click GENERATE. Type this 16-character, lower-case password into the Email password field and click Save.

If the Send email box is checked, an email will be sent just prior to the system returning to the camera Home position if the following conditions are met:

- After each data collection sequence is complete and data is saved
- After a target object has been identified and tracked until lost to view
- The system accepts the tracking sequence (e.g., it was long enough) and just prior to the system returning to the camera Home position.
- Recording was enabled

Note that Gmail imposes a limit of 20MB to the sum of all attachments. OTDAU will attempt to attach all the collected files up to this limit and notify you via the Status box of what was attached and what could not be attached due to this limit.

The log file is included as an attachment to the email.

---

## Upload Data

Collecting potentially valuable scientific data using UFODAP software and either UFODAP- or User-provided hardware is only the first step toward UAP investigation.

The primary objective of the UFODAP team of “citizen scientists” is to submit data of interest for objective evaluation by UAP experts and scientists with the goal of learning about new aspects of the phenomena and ultimately publishing peer-reviewable papers in the same way that any scientific subject is pursued.

Toward that end, UFODAP, the UFODATA Project (<https://www.ufodata.net/>) and the Scientific Coalition for UAP Studies (<https://www.explorescu.org/>) have worked together to develop a means for any UFODAP user to submit their data for evaluation. UFODAP OTDAU software includes the means to select, identify, annotate, decimate for clarity and upload data to a common database. UFODATA along with the SCU are providing skilled personnel to evaluate this data and provide feedback to the contributor and a means to compile such data for comprehensive understanding of the UAP phenomenon.

To participate in this research process, please review the “UAP Data Collection and Contribution Guidelines” document which can be found in [ufodap.com](http://ufodap.com), Downloads. This document provides a format for a Narrative document that must be included with each upload. It also provides guidelines for the use of various types of equipment and the UFODAP OTDAU and Mission Control software including equipment setup, location selection, calibration, testing, how to select useful data and more. Please use this document to guide your efforts toward data collection and use the features described below to submit your data via the form shown below.

**Unique identifier for this submission** – To create a new submission, Enter your last name in the Contributor field. Then clicking in the Unique Identifier field will create an identifier for your submission consisting of your last name and the date and time. To open an existing submission, clicking in the field will open an Explorer window. Double-click or click Open to select a prior submission.

**Contributor last name** – Enter your last name (surname) to identify the submission.

**Sensor locations(s)** – Enter a brief description of the location of the sensor(s) used for the data collection. Longitude/Latitude is optional but preferred.

**Sensor type(s)** – Enter a list of sensors used for the data. For example, “Dahua 50432 camera and MSDAU”

**Narrative folder** – Click in this field to show an Explorer window in which you can then browse to the folder containing the Narrative file in the format “Narrative-10-15-24.txt”. The file type can also be .pdf or .doc or .docx. The date should match that created in the identifier. This is a file that you created in some other app, such as Word, to provide any descriptive information you feel is necessary to describe the data and how it was collected.

**Mission Control folder** -- Click in this field to show an Explorer window in which you can then browse to the folder with MC data created during the data collection.

**OTDAU 1 group folder** -- Click in this field to show an Explorer window in which you can then browse to the folder containing the data created by one of two instances of OTDAU.

**OTDAU 2 group folder** -- Click in this field to show an Explorer window in which you can then browse to the folder containing the data created by a second instance of OTDAU, if that was operational during the data collection, for example, used for triangulation.

**Start time** – Enter the number of seconds from the start of any .avi files to include.

**Stop time** – Enter the number of seconds to the end of the necessary .avi data files. All .avi files discovered as part of OTDAU or MC files will be decimated such that the length of the resulting file will be Stop-Start in length.

An example of a completed Upload form:

The screenshot shows a software window titled "OTDAU -- Optical Tracking Data Acquisition Unit Version 2.26 10-x-24". The main content area is titled "Upload Data to UFODATA for Analysis".

Fields and values shown in the form:

- Unique identifier for this submission: Jones-10-15-24\_17-54-53
- Contributor last name: Jones
- Contributor email address: Jones@gmail.com
- Sensor location(s): Portable station in field near home
- Sensor type(s): Camera and MSDAU
- Narrative file: D:/dropbox-test/Narrative-10-10-24.txt
- Mission Control folder: None
- OTDAU 1 group folder: D:/dropbox-test/dahua-49425-130-1920x1080-10-05-24\_18-07-51
- OTDAU 2 group folder: None
- Start time: 10
- Stop time: 15

Buttons at the bottom: New, Open, Save, Submit, Withdraw, Close window.

## **Control buttons**

**New** – To create a new submission, first enter your Contributor last name (surname) and then click New. A new Unique identifier will be created. Fill in the rest of the form and then click Save.

**Open** – Displays an Explorer window to select a previously created submission form.

**Save** – Saves the current form for future reference or updates.

**Submit** – Uploads the selected Narrative file followed by all files discovered under each of the MC, OTDAU 1 and OTDAU 2 folders. These include all files with dot extensions .txt, .pdf, .avi, .json or .csv.

**Withdraw** – Deletes any folder/files submitted under the selected identifier.

**Close window** – Closes the Setup Options window. If the window is closed before any changes to settings are Saved, then those changes are lost.

Following any Submit or Withdraw, an email containing a summary of the operation (but not including the files themselves) is automatically sent to the UFODATA staff to alert them to the availability of new data or the deletion and implied non-usability of prior data. A confirming email is also sent to the contributor. The selected files are uploaded to the UFODATA database.

It may be useful to pull together into one top-level folder all the files and folders that were used for one submission. This makes it easier to locate the files/folders for selection in the form as well as to remember what was submitted.

If you want to include any additional files, such as .jpg photos from a DSLR camera, then move or copy them into an OTDAU or MC folder already selected prior to initiating Submit. They will be uploaded along with other files found there.

For example, for the data in the above form, it was all accumulated into the folder D:\UAP Data Submission, as shown below:

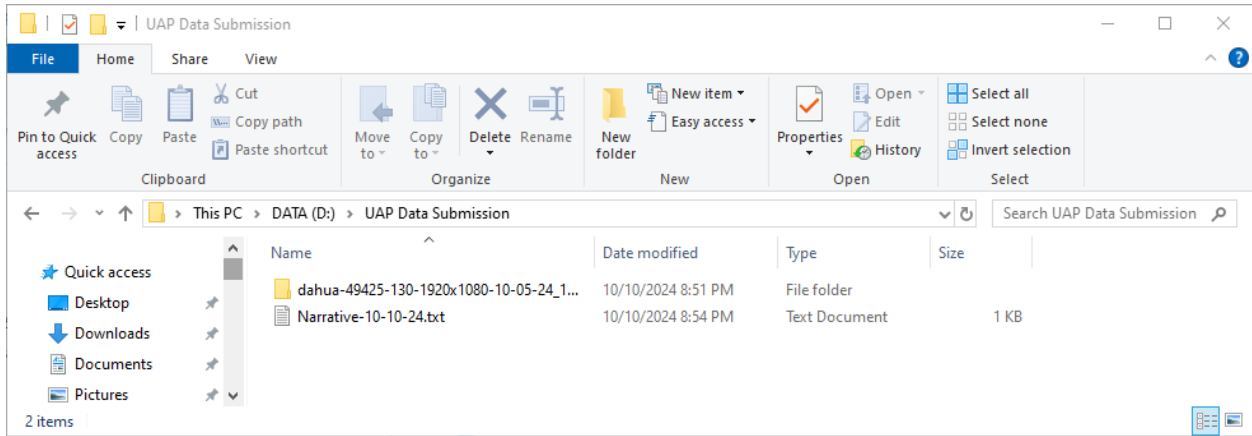

Expanding the OTDAU data folder above gives:

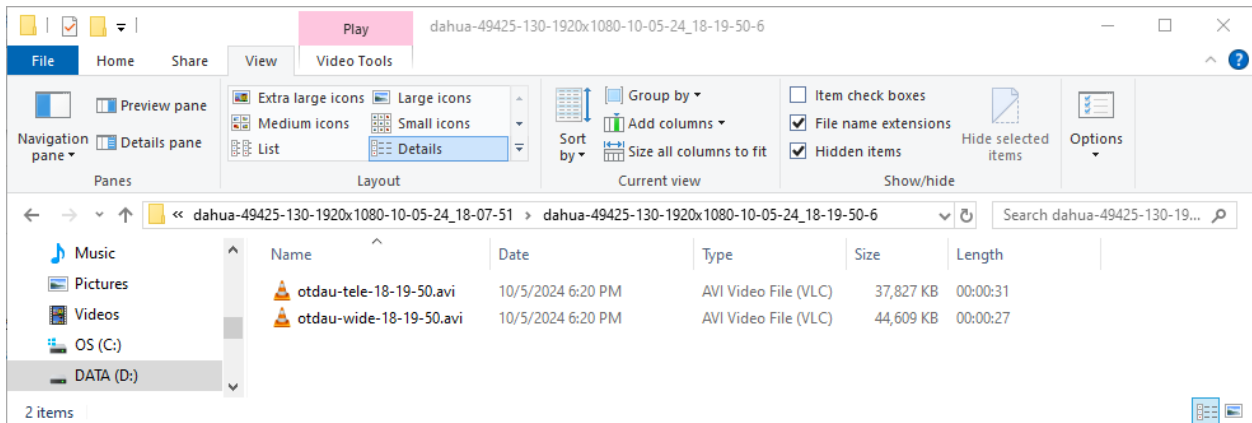
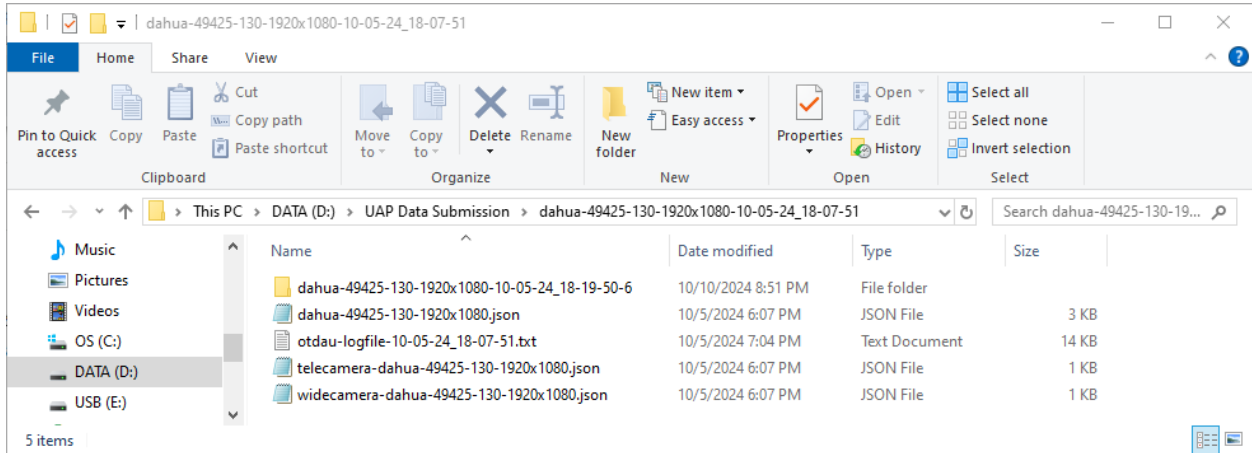

All of the files above would be uploaded to the UFODATA database, as shown in the example below:

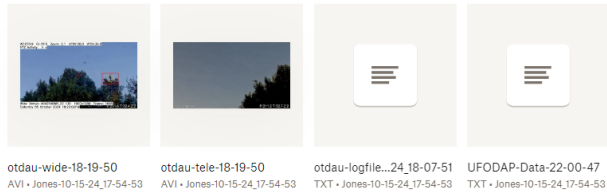

otdau-wide-18-19-50 AVI • Jones-10-15-24\_17-54-53  
 otdau-tele-18-19-50 AVI • Jones-10-15-24\_17-54-53  
 otdau-logfile...24\_18-07-51 TXT • Jones-10-15-24\_17-54-53  
 UFODAP-Data-22-00-47 TXT • Jones-10-15-24\_17-54-53

All files / Apps / UFODAP Data

**Jones-10-15-24\_17-54-53** @

Only you

Recents Starred

Name ↓	Who can access	Modified
widecamera-dahua-49425-130-1920x1080.json	☆ Only you	10/15/2024 10:01 ...
UFODAP-Data-22-00-47.txt	☆ Only you	10/15/2024 10:00 ...
telecamera-dahua-49425-130-1920x1080.json	☆ Only you	10/15/2024 10:01 ...
otdau-wide-18-19-50.avi	☆ Only you	10/15/2024 10:01 ...
otdau-tele-18-19-50.avi	☆ Only you	10/15/2024 10:01 ...
otdau-logfile-10-05-24_18-07-51.txt	☆ Only you	10/15/2024 10:01 ...
dahua-49425-130-1920x1080.json	☆ Only you	10/15/2024 10:01 ...

The corresponding email sent will look like:

**\*\*\* UFODATA Upload Activity at 13:48:34 \*\*\*** Inbox x



**team.ufodap@gmail.com**

to me ▾

**\*\*\* UFODAP Data Upload to UFODATA at 13:48:34 \*\*\***

Total number of uploaded files: 0

Total folders uploaded: 0

UFODATA contribution summary -----

Contributor name: Jones

Sensor locations: Portable station in field near home

Sensor types: Camera and MSDAU

Narrative file: D:/dropbox-test/Narrative-10-10-24.txt

Mission Control folder: None

OTDAU 1 folder: D:/dropbox-test/dahua-49425-130-1920x1080-10-05-24\_18-07-51

OTDAU 2 folder: None

Event files saved to folder: Jones-10-15-24\_17-54-53

---

## How to interpret UFODAP data files

The following is intended to provide some guidance for UFODAP data interpretation and analysis. For additional information, please refer to the **UAP Data Collection and Contribution Guidelines** document. For more details about what types of files a user might collect, please see the **UFODAP User Guide** sections on Recording.

**The best way to really understand what the various options mean and how they affect recorded data is to exercise the OTDAU and MC software, even without actual cameras or an MSDAU. The built-in “test-xx.json” avi files are provided for that purpose.**

## JSON files

---

The result of entering or changing any configuration in OTDAU or MC, such as a System, Camera or Mission, is the creation or modification of a text file with an extension of json, an industry-standard format. JSON files govern all operations of the software and are saved or loaded when any Save or Load operation is applied.

All json files associated with an OTDAU System or MC Mission are saved along with any data folders created in the group folder of the System or Mission. When the user uploads any group folder, all files under it, including the json files, are also uploaded. Since these files fully describe the system configuration used at the time of data collection, they serve as a reference to how the data was collected such as Tracking settings and Camera configuration details.

## OTDAU Data

A user might submit data in any combination of allowed recording options, as shown in the Recording Options window:

The screenshot shows the 'Recording Options' window in OTDAU. The window is titled 'OTDAU -- Optical Tracking Data Acquisition Unit Version 2.26 2-5-26 Beta'. The main title is 'Recording Options'. The window is divided into several sections:

- Recording Options:** Radio buttons for 'Disable recording' (selected), 'Enable recording', and 'Enable recording until manually disabled'. A 'Data path' text box is to the right.
- Primary Video and Data Options:** Checkboxes for 'Wide video with text', 'Wide and Tele frames', 'PTZ data values to CSV file', and 'Save a jpg of the digitally zoomed image of each detected but not tracked event'. Input fields for 'Frame Interval' (0.0) and 'Data Interval' (1.0).
- Audio Recording Options:** Radio buttons for 'None' (selected), 'Wide camera audio from RTSP stream or USB', 'Tele camera audio from RTSP stream or USB', and 'Internal or external USB-connected microphone'. Input fields for 'Channels (1 or 2)' (1) and 'Recording rate' (44100).
- Auxiliary Video Options:** Radio buttons for 'None' (selected), 'Tele video without text', 'Tele video with text', and 'Wide video with digital zoom'. Checkboxes for 'Automatically delete Path files with linear paths', 'Tracking status', 'Path of target detections', 'GPS/ADS-B aircraft tracking', and 'Spectrum video and CSV of peak wavelengths at Data Interval'. A 'Pre-detection recording time in seconds' field (0.0) with a green progress bar below it.
- DSLR Control Options:** Checkboxes for 'Take one photo upon initial move to target and one each shutter interval' and 'Record video during tracking'. A 'DSLR camera shutter release interval or maximum video recording time' field (0.0).

At the bottom of the window are 'Save' and 'Close Window' buttons.

Video files – extension .avi

- All video files are recorded per parameters, such as FPS, recording codec and FOV specified in the Camera configuration for the camera used. See the Camera Configuration section for details of each parameter.

Selections “with text” refers to the inclusion of on-screen metadata that is recorded along with the video content. This text may include

The real-time values of the camera’s pan, tilt (azimuth and elevation) and zoom

- Compare these to the motion in the video to understand how camera motion might affect what is being recorded

Camera horizontal and vertical field of view (FOV)

- Use to verify how much of the scene is captured and for angular calculations

Real-time PTZ Activity – Indicates if the camera has been given P, T or Z motion commands.

- Helps to understand what aspects of motion of the target of interest is due to the target's motion and what may be due to camera motion.

The type of camera, usually a model number

- Verifies user narrative as to what type of camera was used for the recording.

The camera's digital image resolution

- Use for calculating available target resolution and expectation of detail.

A running frame number (rolls over to 1 at 9999)

- Use for motion timing, knowing the frame rate as shown in the Camera configuration window.
- Use in the Analytics function to note frame numbers of details when using frame stepping.

The day and time of the recording

- Validates when the recording was made.

The camera itself might be enabled to generate on-screen text showing its PTZ values

- Use to validate the overlaid text and sometimes get more accurate PTZ values per frame.

Below is an example of what a recording might look like with text enabled:

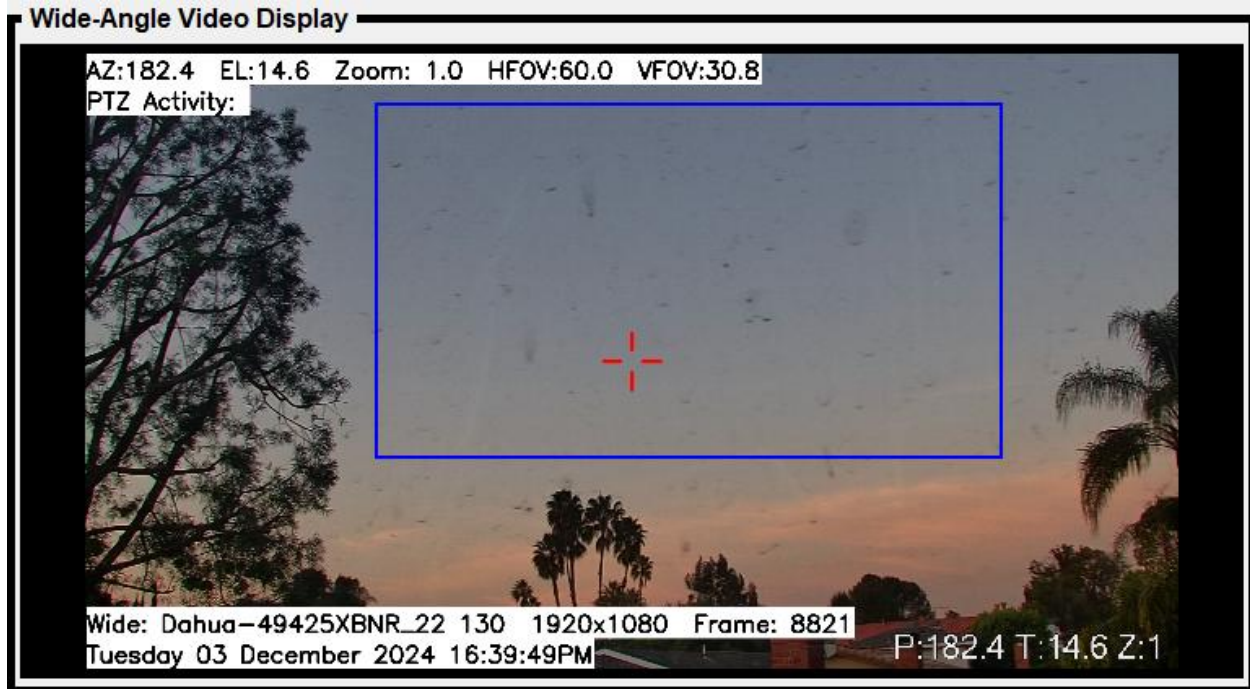

If the **Path of target detections option** is selected, then a video file would be generated that shows the path of the tracked target during each tracking sequence. The key application of this type of data is to note track paths with sharp angular deviations. The recording will include a circle at any part of the path where a sufficient deviation occurs. OTDAU automatically notes such paths by appending a notation to the recording folder name.

If the user provided the “**PTZ data values to CSV file**” option data, then you can drop that data into an Excel spreadsheet and plot the motion of the tracked target.

If the user set a **Pre-detection recording time** (>0.0), then the recording will start at a time prior to target detection and tracking. Use this information to understand what the target was doing prior to the detection.

If the Wide and Tele frames option is selected, a set of individual .jpg frames from the video recording will be generated. The number of such frames would be determined by the selected Frame Interval. Having these may make it easier to do more detailed analysis of the target.

## Setup Options

Operational options that modify system behavior during run time. These selections are saved in a text file in C:\OTDAU when a System configuration is closed or you Quit out of OTDAU. They are read whenever the corresponding System configuration is opened. If you click Load without selecting a configuration, OTDAU automatically selects the last configuration Loaded or provides a list of recent configurations to choose from.

Setup options are organized into three subsections:

- Display
- PTZ Control and Tracking
- AutoStart

The contents of each of these sections are described below.

## Display options

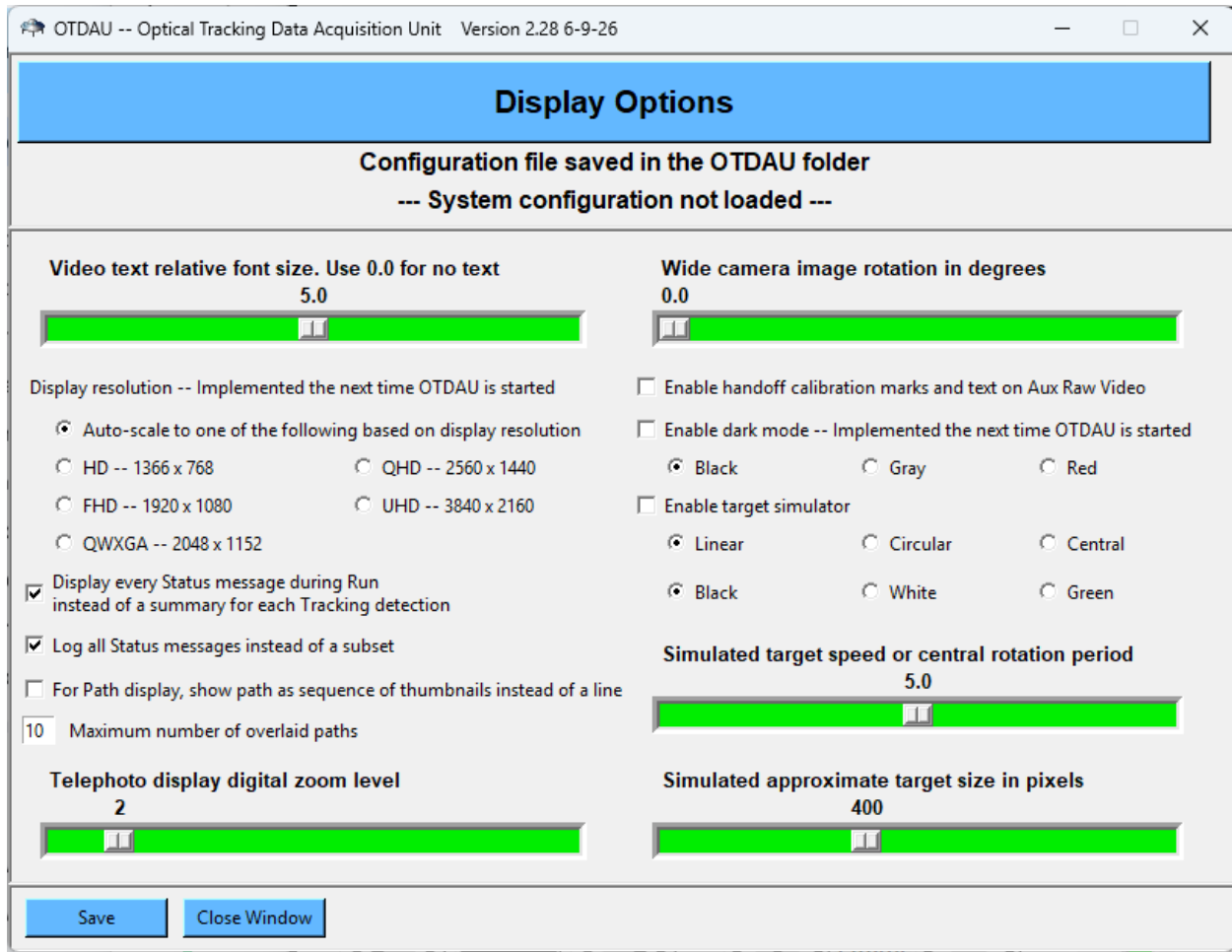

**Video display relative font size** -- Video display text font size is control slider. Set the slider from 0.0 to 10.0 for relative size control. If set to 0, no overlay text will be displayed. Click Save to immediately see the effect on video overlay text. The size value is saved in the configuration file for the currently loaded configuration. **(NOTE: All sliders can be adjusted by moving with the mouse or by clicking on either side of the slider. Holding the mouse down will move the slider in the direction of the mouse.) NOTE: Take care not to eliminate text you may later want to record for identification and analysis.**

**Display resolution selections** -- The size of the OTDAU display may be changed to better fit the available computer monitor size. If Auto-scale is selected, then OTDAU uses a size based on the detected monitor size. Selecting one of the

other sizes forces OTDAU to use that size. The size is implemented when OTDAU is started and not when the display resolution selection is saved.

**Enable every Status message during Run** (verbose mode) – Enabling verbose mode attempts to display all OTDAU process messages. Default is verbose mode OFF which provides summary messages for target tracking but uses verbose mode when OTDAU is Stopped. Both modes attempt to display as many messages as possible, but some will not be visible due to higher speed of message generation than display. Messages may be manually scrolled when the system is Stopped. System Performance measurements are displayed every three seconds during Run only in Verbose display mode.

**Log all Status messages instead of a subset** – Normally, the size of the Log file is limited by only logging the most relevant fixed subset of all status messages. Enabling this option will log all messages.

**For Path display, show path as a sequence of thumbnails instead of a line** -- The Path display may now show the path of the target object as a series of small thumbnails of the Telephoto view. A thumbnail view of the tracked object is also shown in the upper right of the display. Select this option in Setup > Display, “For Path display, show path as sequence of thumbnails instead of a line”. See how it works by using some of the test videos.

**Maximum number of overlaid paths** -- The Path display has the potential to become quite cluttered when a substantial number of paths are collected during operation. To maintain clarity and usability, the system allows you to set a maximum count for the number of overlaid paths displayed at any given time. Once this threshold is reached, the display will automatically reset, enabling the collection and visualization of additional paths without overwhelming the interface. During a single run, all paths are assigned a unique sequence of increasing path numbers. These numbers correspond directly to folder numbers, ensuring clear organization and easy reference. This numbering remains consistent regardless of the total number of path sets collected throughout the session.

**Telephoto display digital zoom level** – The Telephoto selection for the Auxiliary Video Display shows a digitally centered and zoomed image of the currently tracked object. The level of digital zoom can be adjusted from 1 to 10 by this sliding control and is shown on the display.

**Wide camera image rotation in degrees** – The orientation of the Wide video image can be rotated by sliding this control from 0.0 degrees to 360.0 degrees. This is

particularly useful when setting up an ASC camera in handoff mode so that the image may be rotated such that the top of the view corresponds to what is due North of the camera.

**Enable handoff calibration marks and text on Aux Raw Video** – Displays lines and text on the Wide display to indicate the four compass directions and enables camera and date/time data to be displayed on the Aux Display. Useful for setting up two cameras in Handoff mode.

**Enable handoff calibration marks and text on Aux Raw Video** -- Check to cause OTDAU to draw short horizontal and vertical calibration marks on the sides of the Wide camera view. This is helpful when determining the actual FOV of a camera for entry into a camera configuration.

**Enable Dark mode** – If enabled and OTDAU is Quit and run again, then all display backgrounds are shown in the selected color – Black, Gray or Red. This may aid display viewing in low-light conditions. To return the display to its normal background, disable this option and restart OTDAU.

**Enable target simulator** – When enabled and a System configuration is Run, a small moving round dot is shown that moves in either a selected linear or circular path. The color of the dot may also be selected for optimal tracking detection based on the background color of the video. OTDAU software adds the dot to the image from the Wide camera such that all subsequent processing assumes that the dot is an actual part of the camera video stream.

**Linear, Circular, Central** – Selection for type of simulated target: Linear moves a dot from right to left, lowers, then moves left to right, then raises again. Circular moves in a circular pattern with a radius size that depends on the vertical video frame size. Central moves a dot in a small area around the CFOV.

**Black, White, Green** – Selection for the fill color of the target simulation dot.

**Simulated target speed or central rotation period** – The relative speed of the simulated target dot.

**Simulated approximate target size in pixels** – The relative size of the simulated target dot. The cluster size as measured and displayed in Status during tracking will only approximate this value.

## PTZ Control and tracking options

OTDAU -- Optical Tracking Data Acquisition Unit Version 2.26 2-5-26 Beta

### PTZ Control and Tracking

Configuration file saved in the OTDAU folder  
C:/OTDAU/ConfigFiles/dahua-49425-130-1920x1080-sysconfig.txt

#### PTZ Control options

None

Slave PTZ motions of the tele camera to wide camera motions on this OTDAU

Slave PTZ motions of the wide camera on this OTDAU to wide camera motions on a Master OTDAU via Mission Control

Enable Handoff from wide to tele camera on this OTDAU

#### Tracking options

Target detection and tracking by motion

Target detection by template matching

Target detection by motion and tracking by template matching

Confine the area of each new crop box resulting from each tracking detection to within the original bounding box  
Otherwise, allow tracking to continue beyond the original box

Enable sun avoidance  Enable night image background suppression

Enable Autocruise  Background sampling period

Autocruise sensitivity  Time between sampling periods

#### Pan and Tilt additional offsets

Azimuth offset  Elevation offset

## **PTZ Control options**

**None** – Normal, non-slaved control

**Slave PTZ motions of the tele camera to wide camera motions on this OTDAU** – Echoes the pan and tilt angles of the Wide camera to a PTZ Tele camera. This happens within the OTDAU software.

**Slave PTZ motions for this OTDAU to a Master OTDAU via Mission Control** –

Enables designation of this copy of OTDAU to be a Slave. Any number of slaved OTDAUs with PTZ cameras will follow the motion of the Master, including manual positioning for setup and homing as well as triggered recording. Slave camera manual PTZ controls will also function normally. If a slave is enabled for recording, then its Manual recording function is available, and it will also start recording whenever the Master does. This feature allows one camera to be used to detect/track a target while pointing several other cameras (or other equipment on independent pan/tilt heads) at the same target. This feature depends on also running Mission Control through which all Master data is distributed to Slaves. Before use, align all cameras to the same CFOV and enable Slave for any OTDAU instances that need it. Then, save the setup. NOTE: Triangulation may be operational in this configuration but would not be valid. OTDAU Telephoto, Tracking, Path and Spectrum options are not available in any slave since tracking and target position data did not originate with the slave. Be aware that the FOV of any slave will not perfectly correspond to that of the Master, with an offset related to the distance between them.

To slave an instance of OTDAU:

- 1) Move the Master to its home position,
- 2) Move the Slave so that its CFOV aligns with that of the Master
- 3) In the Slave Setup Options, enable Slave PTZ motions and Set Pan and Tilt offsets which zeroes its AZ and EL indications.

Enable recording in Master and/or Slave as desired. Test by manual PTZ control of the Master and observe the corresponding motion of the Slave.

## **Enable Handoff from wide to tele camera**

**if not enabled, tele follows wide** – Enables the system to handoff target detection and tracking to a telephoto PTZ camera after initial detection by a wide fixed-field unit such as a 360-degree panoramic camera. The wide camera makes the initial

detection and then the tele camera is pointed to the approximate location of the target. The tele camera then proceeds with its own detection and tracking as if it had made the initial detection. This re-detection process compensates for inaccuracies in pan/tilt values derived from the target location from non-linear optics such as an All-Sky (panoramic) camera. Use the manual motion controls to align then center of the PTZ (Tele) camera with the center of the Wide camera prior to tracking. Handoff operations occur within the OTDAU software.

**NOTE:** Setup for Handoff using a non-ASC fixed camera (or PTZ camera with PTZ disabled), in typical situations where the target is distant – Instead of aligning the crosshairs, use manual motion to initially point the tele camera in the same compass direction as the wide camera. That is, move the tele PTZ camera such that its pan and tilt angles match that of the wide camera. When using a fixed wide camera, move the tele PTZ camera so that its direction of view is parallel to that of the wide camera. Use a larger Crop increment and Event interval than normal. Use the Display setup option to rotate the ASC view so that objects to the North are at the top of the display.

**NOTE:** When in Handoff mode and tracking results in a handoff to the Tele camera, the PTZ position data and video frame sent to MC changes from Wide to the Tele camera data.

### **Target detection and tracking by motion, Template matching, or both --**

Alternate tracking methods are provided to support “star tracking” or similar targets. If a target is visible prior to Run, then it may be manually designated as the tracked target. In Setup > Tracking there are three options: Target detection and tracking by motion (the original method), both detection and tracking by template matching and detection to set the template by motion detection but tracking by matching. To use template matching, draw a tight bounding box around the target of interest and then Run. OTDAU will capture the first frame after Run as a template and attempt to identify the same target in all subsequent frames. To use the first or third option, use a larger bounding box, a low value of Tracking > Min events to allow faster recognition of initial target motion and a Crop increment greater than 2. Bounding box, and target location indication are the same as in normal tracking mode. Use with Tracking Settings > Max time set to 0 for long-term tracking. Useful for targets of any speed but particularly for slow-moving such as celestial objects or satellites. See the ISS and jet-clouds test configurations for examples.

**NOTE:** Template matching alone does not use any of the non-time Tracking parameters. It may lose lock due to target size and orientation changes. It does not function well if in Handoff mode due to a non-specific initial frame crop area. Template matching automatically terminates tracking if the quality of a match is significantly different than the last successful match.

When template matching is enabled, the Wide camera video display shows a thumbnail frame of the template with a SSID (deep learning) assessment of the object ID with its confidence value below it and, if the confidence is zero, UNKNOWN. The resulting object class and confidence level are appended to the Wide video filename if that option is selected in Analytics.

**Confine the area of each new drop box...** -- This option will cause tracking, particularly for fixed (non-PTZ) cameras to be limited to within the originally defined bounding box or circle. The target will only be detected and tracked if it is within that area. Otherwise, allow tracking to continue beyond the original box". This eliminates the issue of a target continuing to be tracked into surrounding foliage and thus useless detections. The target crop box will be limited to the area inside of the original bounding box. This feature is intended to be used only with fixed cameras or PTZ cameras with pan/tilt disabled. It is particularly helpful in daytime conditions when the bounding area is intended to prevent false detections in surrounding foliage. **NOTE:** This function cannot be used for Handoff or tracking by template matching.

**Set Pan and Tilt Offsets** -- Check to cause OTDAU to create offsets to the current pan and tilt positions such that the offset positions rather than the actual positions are sent to MC during triangulation. This option is typically set after pan and tilt have been manually moved to due North and the horizon. If this box is checked and then you click Save, OTDAU samples the current pan and tilt values of the camera and saves them. Until this box is unchecked, OTDAU subtracts these values from the actual camera pan and tilt values to provide offset values used for the AZ and EL displays and for data to MC.

Offsetting pan and tilt is also helpful to set, as above, prior to any PTZ camera Run so that the actual azimuth and elevation of the camera are saved for later image analysis.

**Azimuth offset** -- If Pan and Tilt Offsets is checked, this value is added to the net offset for pan at Run time. This may be used to emulate a PTZ camera for triangulation when using a fixed camera to obtain a desired azimuth angle regardless of the camera's actual angle.

**Elevation offset** -- If Pan and Tilt Offsets is checked, this value is added to the net offset for tilt at Run time. This may be used to emulate a PTZ camera for triangulation when using a fixed camera to obtain a desired elevation angle regardless of the camera's actual angle.

**Avoid Sun** -- Check to cause OTDAU, during Run time, to continuously measure the brightness of the brightest spot on the Wide image of a PTZ camera. If this spot sufficiently increases in brightness, indicating that the camera has the sun in its FOV, then the system will move the camera up, away from the sun, for one second. Scanning for motion will continue at the new position. Do not use this option if the type of object that may be detected is very bright, otherwise tracking will be lost just after it starts.

**Enable Autocruise** -- Check to enable the Autocruise process. This is a feature designed to maximize target viewing time despite the target passing a foreground or background object, such as tree foliage, that may confuse the tracker. Autocruise works by continually monitoring the velocity of the target. When the velocity makes a sudden change, as defined by the sensitivity value, the tracker stops attempting to directly track the object and instead continues smooth PTZ motion in the direction and at the velocity of the object last measured prior to the change. OTDAU will stay in Autocruise until the end of the current tracking event sequence.

**Autocruise sensitivity** -- Enter a relative value that will be used when Autocruise is enabled, to determine the level of velocity change required to cause the system to go into Autocruise mode. A larger value is more sensitive.

**NOTE:** OTDAU emulates azimuth and elevation values for fixed cameras and PTZ cameras when pan/tilt is not enabled. Values are 0/0 when not Running. During Run, AZ is 0 when no target is detected. During tracking, the angle is 0 when the target is centered in the horizontal FOV. Values increase when the target moves right. Values decrease, starting at 360 degrees when the target moves left. EL is ½ of the vertical FOV when no target is detected. During tracking, the angle increases as the target moves above center and decreases when it moves down. The total horizontal and vertical angle ranges are proportional to the camera's particular FOV. You can zero out these values (or offset them) using Setup > PTZ Control and Tracking > Set Pan and Tilt offsets. AZ/EL emulation is important for using non-PTZ cameras for triangulation via Mission Control.

**Enable night image background suppression** – Enables the automatic, periodic identification of non-moving night sky objects. This feature uses this identification to ignore such objects when qualifying actual new, moving objects to become tracking targets. The screenshot below is an example of this process using the test-night-stars.json test configuration. Each purple circle encloses an object that has been detected with intensity above an internal threshold. Any new object that is found inside the bounding box after the initial background sampling period is detected and tracked while fluctuations in the background objects are ignored.

Background objects to be excluded are determined by sampling during the Background sampling period entry, in seconds. The sampling period and its termination are indicated by onscreen display messages.

Since the background may change over time (e.g., stars shift position), the sampling process is periodically repeated at a rate set in seconds by the Time between sampling periods entry.

All excluded objects are displayed as green circles in the Raw Video display. Note that if a potential target is moving during the sampling period, then every point it passes through during the sampling period will be part of the exclusion set.

Note: To avoid the effects from very small objects, it may be necessary to increase the values of Blur to perhaps 7 and Delta threshold to about 25. Some experimentation may be required, pre-Run, to get the best results.

Wide-Angle Video Display

AZ: 25.0 EL:15.0 HFOV:50.0 VFOV:30.0

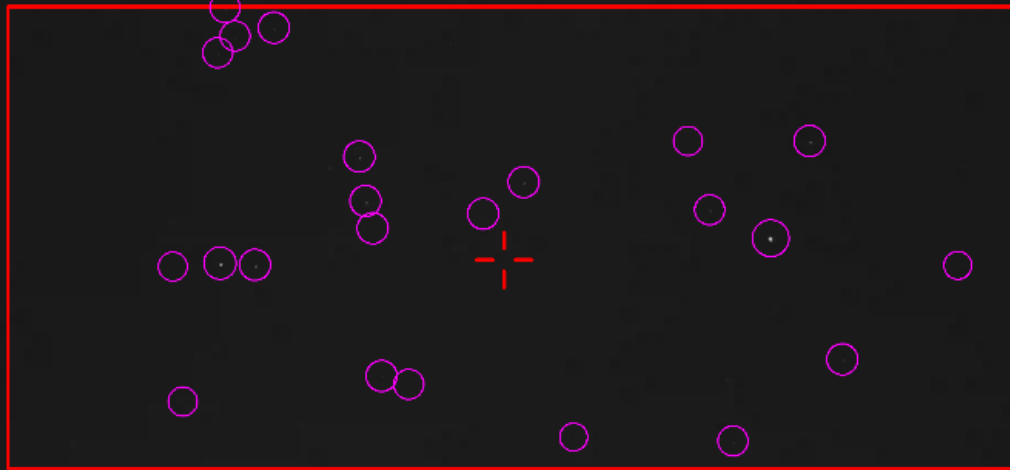

Wide Camera: Test night tracking 1920x1080 P:34.0 T:41.5 Z:1  
Wednesday 18 Nov 2020 13:53:55PM Frame: 477

## AutoStart Setup

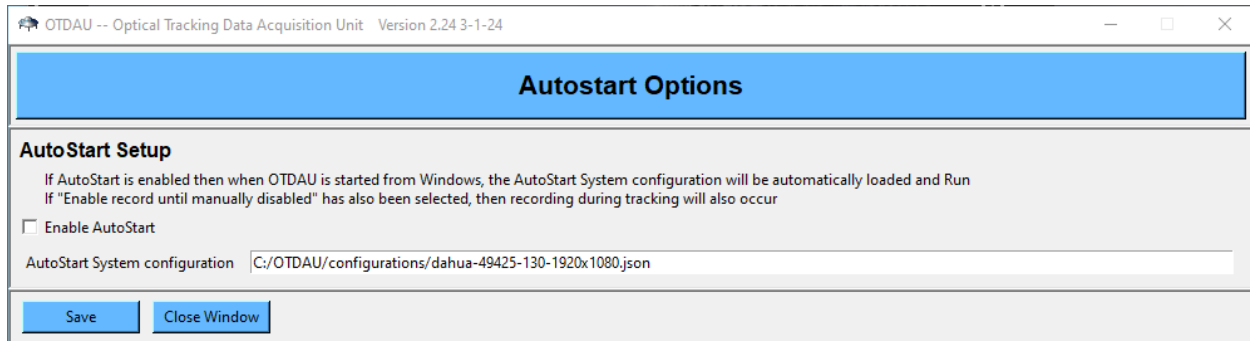

OTDAU can automatically Load and Run any System configuration when starting from Windows. This may be useful for situations where system power may not be reliable – when power drops out and then returns, and the computer reboots, OTDAU can restart, running, with the same options enabled as when power went down.

AutoStart may also simply be used to manually startup OTDAU in a Run mode in the least time.

If AutoStart is enabled and a System configuration is selected and saved, then when OTDAU first starts up, that configuration is Loaded and Run. Disable AutoStart to start up normally but retain the selected System configuration. AutoStart may be used with or without the Record until disabled option to automatically start, run and record during tracking just by running OTDAU.

Use Windows Task Scheduler or another method of your choice to automatically start OTDAU during Windows startup.

**Enable AutoStart** – Enables automatic Load and Run the next time OTDAU is started.

**AutoStart System configuration** – Clicking in this field will open a list of System configurations. Selecting one of those will populate this field with the selected configuration.

## Help

### About

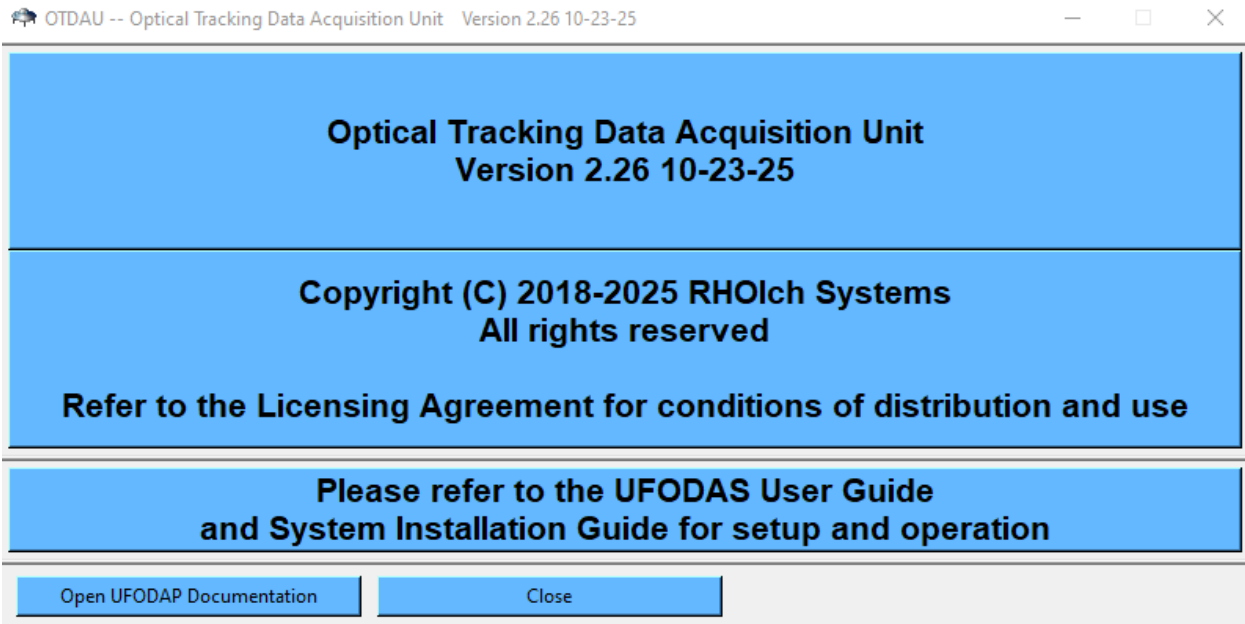

This window shows the current version of OTDAU software. The version is also shown at the top of the main display. Clicking on “Open UFODAP Documentation” will also open the ufodap.com Downloads page in a browser window.

## Manage license

Displays the license validation GUI. Allows the key and camera information to be modified or re-validated. Use this option to, for example, implement an IP camera for validation instead of a USB camera or use a different IP camera for validation.

Unidentified Flying Object Data Acquisition System -- OTDAU

### UFODAP Software License Validation OTDAU

Enter your license key below. Upper case including "-"  
Enter your camera information. Modify the defaults shown as required  
For use with USB cameras only, enter "USB" for the Camera IP  
Click Validate to use your license on this computer

License key

Camera IP

Camera HTTP port (usually 80)

Camera User Name

Camera Password

#### Validation Results

Please wait during initialization ... Validation GUI startup completed

**Validate** **Save** **Exit**

Make any necessary changes and then click Save. If not Saved before Exiting, then when Manage Validation is selected again, the original validation information will be shown. Save is automatic whenever Validation is started.

After clicking the Validate button, the Validation Results box shows the resulting validation check results including validation of the key and if the selected camera can be accessed. Both must validate to run OTDAU after clicking the Exit button.

Note that OTDAU can be used with only a USB camera if the Camera "IP" is set to "USB" instead of an IP address.

Unlike Validation when OTDAU or MC is started up, it does not automatically exit after validation when it is run from the Help selection. This allows the user to test different entries before exiting.

# OTDAU GPS / ADS-B AIRCRAFT TRACKING SYSTEM

## Introduction

The GPS / ADS-B Aircraft Tracking System provides real-time aircraft identification and position tracking capabilities integrated with OTDAU's video surveillance system. This feature enables automatic identification and tracking of aircraft within the camera's field of view, helping distinguish conventional aircraft from potential anomalous objects.

### Key Capabilities:

- Real-time GPS position tracking using USB GPS receivers
- ADS-B aircraft reception and decoding on 1090 MHz
- Automatic aircraft identification with callsign, altitude, and distance
- Integration with wide-angle video display showing aircraft overlays
- Comprehensive data logging for post-mission analysis
- Support for up to 150 simultaneous aircraft tracking

### System Components:

- USB GPS Receiver (GNSS-compatible)
- RTL-SDR USB dongle (ADS-B reception)
- 1090 MHz ADS-B antenna
- GPS/ADS-B software module (integrated with OTDAU)

## ADS-B Receiver Setup with GPS

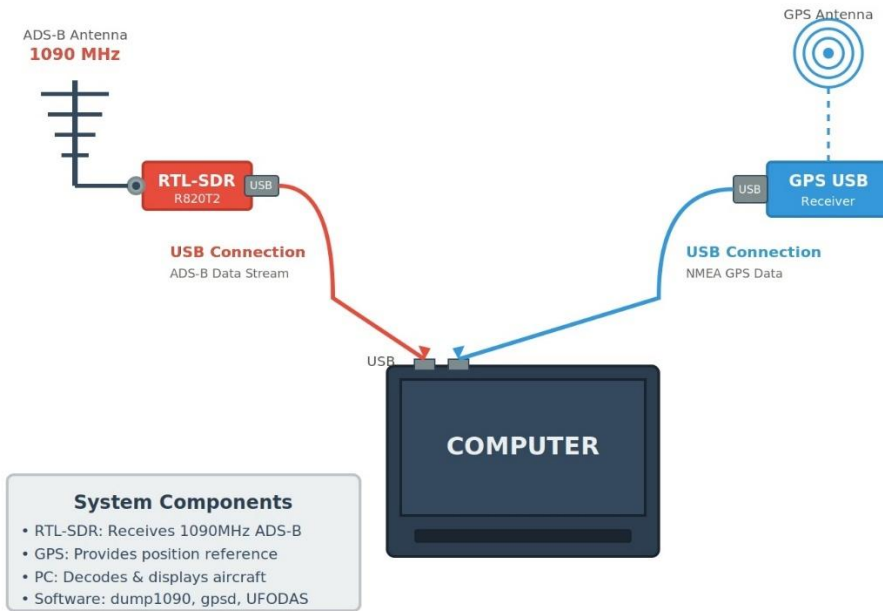

### What is GPS?

GPS (Global Positioning System) is a satellite-based navigation system that provides accurate location, altitude, and time information anywhere on Earth. The OTDAU system uses GPS to:

- Establish observer position - Required for calculating aircraft distance and bearing
- Provide accurate timestamps - Essential for correlating video with aircraft data
- Enable altitude reference - Used for calculating elevation angles to aircraft
- Support position overlay calculations - Maps aircraft positions to video coordinates

### Technical Specifications:

- Accuracy: Typical 3-10 meters horizontal
- Update rate: 1-10 Hz (1-10 times per second)
- Time accuracy: < 100 nanoseconds
- Altitude accuracy: 10-20 meters vertical

---

## GPS Hardware Requirements

### RECOMMENDED GPS RECEIVERS

The system supports standard USB GPS receivers using the NMEA 0183 protocol. Recommended models include:

#### Budget Option (\$20-30):

- **VK-162 USB GPS Receiver**
  - Chipset: U-blox 7
  - Update rate: 5 Hz
  - Connector: USB Type-A
  - Antenna: Built-in patch antenna
  - Cold start: ~30 seconds
  - Note: Adequate for stationary installations

#### Mid-Range Option (\$40-60):

- **Globalsat BU-353S4 USB GPS Receiver**
  - Chipset: SiRF Star IV
  - Update rate: 1 Hz
  - Sensitivity: -165 dBm
  - External antenna option available
  - Widely compatible, reliable performance

#### Professional Option (\$80-150):

- **U-blox USB GPS with External Antenna**
  - Chipset: U-blox 8 or 9
  - Update rate: 10 Hz
  - External active antenna
  - Superior sensitivity and accuracy
  - Best for challenging environments

### GPS ANTENNA CONSIDERATIONS

#### Built-in Antenna (Patch Antenna):

- Adequate for outdoor or window placement
- Requires clear view of sky
- Typical gain: 0-3 dBi

### External Active Antenna:

- Required for indoor installations
- Roof or outdoor mounting
- Typical gain: 25-30 dB
- Cable length: Up to 30 feet (keep as short as practical)
- Requires USB power or separate 3.3-5V supply

### Antenna Placement Tips:

- Clear view of sky (minimum 4 satellites visible)
- Away from metal obstructions
- Avoid proximity to high-power RF transmitters
- Magnetic mount antennas work well on metal roofs



**VK-162**  
USB GPS Receiver



**Globalsat BU-353S4**  
USB GPS Receiver



**U-blox USB GPS**  
with External Antenna

---

## GPS Installation and Setup

### STEP 1: PHYSICAL CONNECTION

The GPS subsystem is designed for plug-and-play operation:

1. Connect USB GPS receiver to an available USB port
2. Windows automatically installs drivers (typically appears as "USB Serial Port")
3. OTDAU automatically detects the GPS receiver on startup
4. No manual configuration required - COM port is found automatically

#### Allow time for GPS acquisition:

- Cold start: 30 seconds to 5 minutes (first time or after long power-off)
- Warm start: 15-45 seconds (recently powered)
- Hot start: 5-15 seconds (continuous operation)

#### Automatic Operation:

- GPS receiver begins acquiring satellites immediately upon connection
- System searches all COM ports for NMEA GPS data
- Once valid GPS data detected, position automatically updated
- No user intervention required

### STEP 2: VERIFY GPS OPERATION IN OTDAU

5. Open Auxiliary Video Display menu
6. Select Option 7: GPS/ADS-B Display
7. GPS status should show within 1-2 minutes:
  - "GPS: Fix OK (N sats)" - GPS operating correctly (green text)
  - "GPS: Acquiring satellites..." - Waiting for fix (gray text)
  - "Location Source: IP Geolocation" - GPS not detected, using fallback (orange)

## GPS Status Messages:

- "GPS: Fix OK (7 sats)" - Normal operation, 3D position fix (green)
- "GPS: Acquiring satellites..." - GPS detected but no fix yet (gray)
- "Location Source: IP Geolocation" - GPS not found, using internet location estimate (orange)
- "GPS: Error" - GPS communication problem (red)



The screenshot shows a software interface for tracking aircraft. At the top, it displays the title "GPS / ADS-B Aircraft Tracker" and a status bar with green text: "GPS: Fix OK (12 sats, HDOP 1.0m) Port: COM4 @ 9600 baud" and "Location (GPS): 34.18963, -118.51060". Below this, it shows "Messages: 286 | Aircraft: 2 displayed, 2 qualified, 174 total". On the right side, there is a control panel with a button labeled "--- Display aircraft ---", a label "Max aircraft in camera FOV", and a numeric input field set to "10" with minus and plus buttons. The main part of the interface is a table with the following columns: IDENT, SYM, SIG, TYPE, AGE, ALTITUDE, LATITUDE, LONGITUDE, VELOCITY, HEADING, DIST, and BEARING. The units for these columns are: s, ft, deg, deg, kts, deg, mi, deg. Two aircraft are listed in the table:

IDENT	SYM	SIG	TYPE	AGE	ALTITUDE	LATITUDE	LONGITUDE	VELOCITY	HEADING	DIST	BEARING
				s	ft	deg	deg	kts	deg	mi	deg
SWA4530	M		Large	0	4075	34.200858	-118.593063	204.0	90.3	16.29	275.0
AA3226	?			0	25625	34.340607	-118.611201	438.0	279.2	20.49	302.7

## GPS Troubleshooting

If GPS does not automatically connect or shows persistent "Acquiring satellites" message:

### Check 1: Verify GPS Hardware Detection

#### Windows Device Manager Method:

1. Press Windows Key + X, select Device Manager
2. Expand Ports (COM & LPT) section
3. Look for device named:
  - "USB Serial Port (COMX)" where X is the port number
  - "Prolific USB-to-Serial"
  - "U-blox GPS" or similar GPS-specific name
4. If device shows yellow exclamation mark:
  - Right-click device → Update Driver
  - Select "Search automatically for drivers"

#### If GPS device not visible in Device Manager:

- Try different USB port
- Check USB cable (try known-good cable)

- GPS may be defective - test on a different computer

---

## **Check 2: Test GPS with Diagnostic Software**

### **Online GPS Test (Recommended for Quick Check):**

Visit [gpsd.io](http://gpsd.io) or [gps-test.com](http://gps-test.com) in web browser:

- Requires GPS receiver connected
- Browser-based, no installation
- Shows satellite view, position, signal strength
- Verify GPS is receiving signals and calculating position

### **Desktop GPS Diagnostic Tools:**

#### **Option 1: U-blox u-center (Professional Tool)**

- Download from: [u-blox.com](http://u-blox.com)
- Free software, full featured
- Shows satellite constellation, signal strength, NMEA sentences
- Best for detailed diagnostics

#### **Option 2: GPS Viewer (Simple Freeware)**

- Search "GPS Visualizer" or "NMEA Monitor" or "VisualGPSView" from <https://www.visualgps.net/#visualgpsview-content>
- Shows raw NMEA sentences
- Verifies COM port communication
- Lightweight, easy to use

## What to Verify:

- GPS acquiring satellites (count should increase to 4+)
- Position calculated (latitude/longitude displayed)
- NMEA sentences flowing (\$GPGGA, \$GPRMC, etc.)
- Satellite signal strength bars visible
- HDOP value < 5.0 (preferably < 2.0)

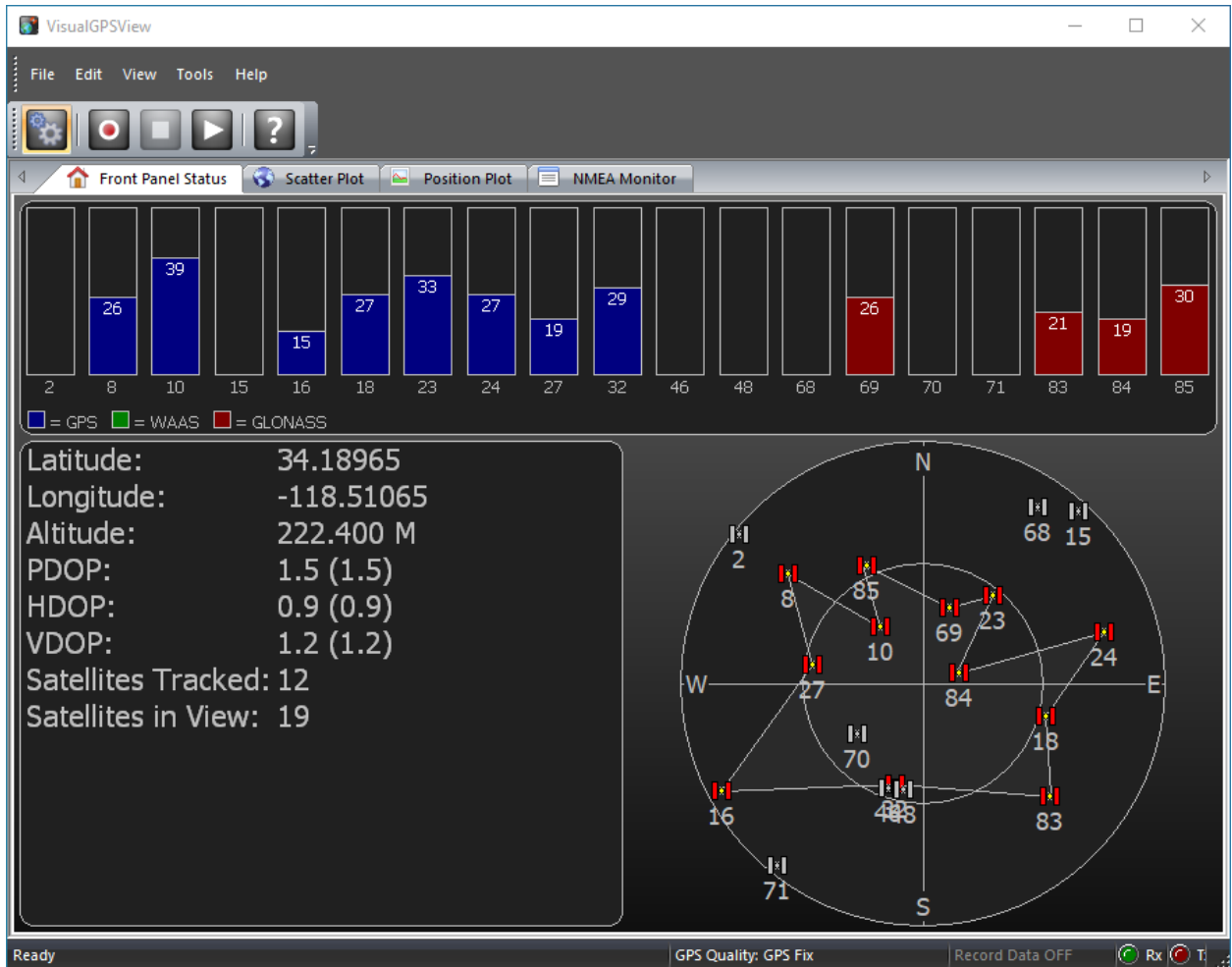

VisualGPSView GPS receiver test

---

### Check 3: Improve GPS Reception

If GPS detected but not acquiring satellites:

#### Antenna Placement:

- Move GPS near window or outdoors
- Ensure antenna faces upward
- Remove obstructions (no metal/concrete above)
- Avoid proximity to high-power electronics

#### Sky Visibility Requirements:

- Minimum 4 satellites needed for 3D fix
- More satellites = faster acquisition and better accuracy
- Typical visible satellites: 8-12 in open sky
- Trees and buildings reduce satellite count

#### Cold Start vs. Warm Start:

- After long power-off, GPS needs to download almanac data
- First fix can take 5-10 minutes with poor sky view
- Subsequent fixes much faster (30-60 seconds)
- Be patient on first use

---

### Check 4: Verify OTDAU COM Port Scanning

OTDAU scans COM1 through COM20 for GPS data. If GPS is on COM21 or higher:

#### Reassign the GPS device to a Lower COM Port:

1. Device Manager → Ports (COM & LPT)
2. Right-click GPS device → Properties
3. Port Settings tab → Advanced
4. Change COM port number to 1-20
5. Click OK, restart OTDAU

---

## Understanding GPS Data

The GPS display shows the following information:

### Satellite Count:

- Number of satellites currently tracked
- Minimum 4 required for 3D position fix
- More satellites = better accuracy
- Typical: 6-12 satellites visible

### HDOP (Horizontal Dilution of Precision):

- Measure of geometric satellite distribution
- Lower values indicate better accuracy
- <1.0 = Excellent
- 1.0-2.0 = Good
- 2.0-5.0 = Fair
- >5.0 = Poor (reposition antenna)

### Altitude:

- GPS altitude above mean sea level (MSL)
- Used for elevation angle calculations
- Accuracy typically  $\pm 10$ -20 meters
- Important for aircraft overlay feature

---

## GPS Fallback Mode

If a GPS receiver is unavailable or not configured, the system automatically falls back to IP Geolocation:

- Uses your router's internet IP address to estimate location
- Accuracy: City-level (typically 5-50 km)
- Sufficient for rough distance calculations
- Display shows: "Location Source: IP Geolocation" (orange)
- Note: Altitude not available in this mode

## ADS-B SUBSYSTEM

### What is ADS-B?

ADS-B (Automatic Dependent Surveillance-Broadcast) is a surveillance technology used by aircraft to broadcast their position, altitude, velocity, and identification. Unlike radar, ADS-B is:

- Automatic - Broadcasts continuously without interrogation
- Dependent - Relies on aircraft's own navigation systems (GPS)
- Surveillance - Provides real-time aircraft tracking
- Broadcast - Transmitted on 1090 MHz, receivable by anyone

### What ADS-B Provides:

- Aircraft ICAO identifier (24-bit unique code)
- Callsign (flight number or registration)
- GPS position (latitude/longitude)
- Pressure altitude (feet)
- Velocity (ground speed and heading)
- Vertical rate (climb/descent)
- Aircraft category (heavy/large/small/helicopter/etc.)

### ADS-B Coverage:

- Required in USA: All aircraft in Class A, B, and C airspace
- Optional: General aviation in uncontrolled airspace
- Mandate effective: January 1, 2020 (USA)
- International: Varying mandates worldwide

## Transmission Specifications:

- Frequency: 1090 MHz (1090.000 MHz exactly)
- Modulation: Pulse Position Modulation (PPM)
- Power: 70-250 watts (aircraft dependent)
- Rate: Varies, typically 0.5-2 times per second per aircraft
- Range: Line-of-sight, typically 100-250 miles for aircraft at altitude

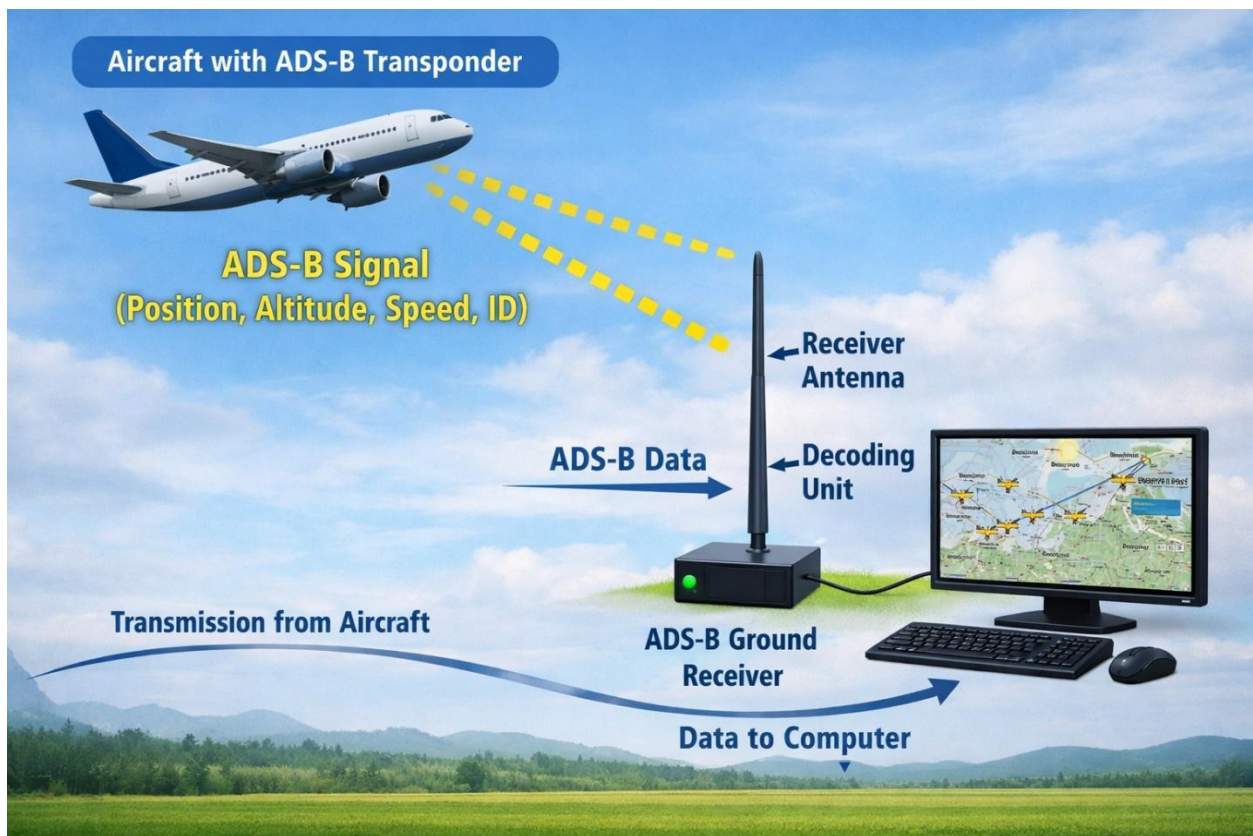

---

## ADS-B Hardware Requirements

### RTL-SDR USB DONGLE

The system uses an RTL-SDR (Software Defined Radio) dongle to receive and decode ADS-B signals.

#### Recommended RTL-SDR Models:

##### Standard Option (\$25-35) - RECOMMENDED:

- **RTL-SDR Blog V3 or V4**
  - Chipset: RTL2832U + R820T2
  - Frequency range: 500 kHz - 1.7 GHz
  - Built-in bias tee (powers active antennas)
  - SMA connector
  - Temperature-Compensated Crystal Oscillator (TCXO)
  - Low phase noise
  - Best value for ADS-B reception

##### Alternative Option (\$30-40):

- **NooElec NESDR Smart or SMARt**
  - Similar specifications to RTL-SDR Blog
  - Aluminum enclosure (better heat dissipation)
  - Metal case shields against interference
  - TCXO for frequency stability

##### Budget Option (\$15-25):

- **Generic RTL2832U Dongles**
  - Basic functionality adequate
  - May lack TCXO (frequency drift possible)
  - Acceptable for testing/evaluation
  - Not recommended for permanent installations

#### **⚠ IMPORTANT - NOT COMPATIBLE:**

- HackRF One - Cannot be used (different architecture, not an RTL-SDR)
- Airspy - Not currently supported (different API)
- Standard TV tuner dongles - Not recommended (poor 1090 MHz performance)



### Why HackRF One Won't Work:

- HackRF is a transmit-capable SDR (not just receive-only)
- Uses different chipset and driver architecture
- OTDAU specifically requires RTL2832U-based devices
- Price: \$300+ vs \$25-35 for RTL-SDR (unnecessary expense)

## 1090 MHz ADS-B ANTENNA

The antenna is critical for good ADS-B reception. Several options are available:

### Indoor Option (\$20-40):

- **Small magnetic mount whip antenna**
  - Gain: 0-3 dBi
  - Length: 6-12 inches
  - Placement: Window ledge with clear view
  - Range: 50-100 miles (aircraft at altitude)
  - Easy to deploy, no installation required

### Outdoor Option (\$40-80):

- **Vertical collinear antenna (dedicated 1090 MHz)**
  - Gain: 3-9 dBi
  - Length: 24-48 inches
  - Placement: Roof or mast mounted
  - Range: 150-250 miles (optimal conditions)
  - Weatherproof, permanent installation

### Professional Option (\$100-200):

- **Filtered preamp + antenna system**
  - Built-in bandpass filter (reduces interference)
  - Low-noise amplifier (LNA) 20-30 dB gain
  - Optimal for urban/RF-dense environments
  - Range: 200-300 miles

### DIY Option (\$5-15):

- **Build your own 1/4 wave ground plane antenna**
  - Materials: Coax cable, SMA connector, wire
  - Resonant at 1090 MHz
  - Performance comparable to commercial antennas
  - Plans available online

# ADS-B Antenna Types Comparison

## Indoor Magnetic Mount Whip \$20-40

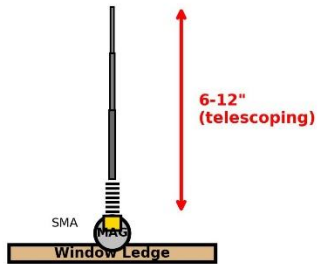

- Gain: 0-3 dBi
- Range: 50-100 mi
- Indoor use
- No installation

## Outdoor Vertical Collinear \$40-80

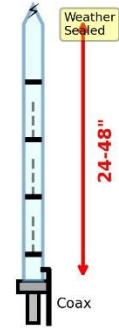

- Gain: 3-9 dBi
- Range: 150-250 mi
- Weatherproof
- Roof/mast mount

## Professional Filtered Preamp \$100-200

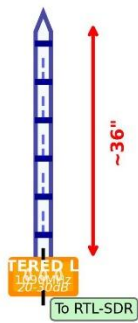

- Gain: 20-30 dB (LNA)
- Range: 200-300 mi
- Built-in bandpass filter
- Urban/RF-dense optimal

## DIY 1/4 Wave Ground Plane \$5-15

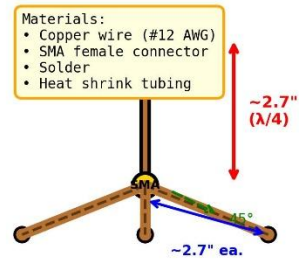

- Gain: ~0-2 dBi
- Range: Comparable to commercial
- DIY construction
- Resonant at 1090 MHz

All dimensions approximate • Performance varies by installation and environment

## **ANTENNA PLACEMENT RECOMMENDATIONS**

### **Height:**

- Higher is better (reduces terrain/building blockage)
- Minimum: Above roofline
- Optimal: 20+ feet above ground
- Every 10 feet of height  $\approx$  4 miles additional range

### **Orientation:**

- Vertical polarization (antenna perpendicular to ground)
- Omnidirectional coverage (receives from all directions)

### **Environment:**

- Clear line-of-sight to horizon
- Away from metal obstructions
- Avoid proximity to other transmitting antennas
- Ground plane antennas need metal surface below

### **Cable Considerations:**

- Use low-loss coax (LMR-240 or better)
- Keep cable length <30 feet if possible
- Every 10 feet of RG-58 cable  $\approx$  2 dB loss at 1090 MHz
- Consider LNA at antenna if a long cable run is required

### STEP 1: CONNECT ANTENNA and INSTALL THE SDR

- 1. Connect 1090 MHz antenna to RTL-SDR SMA connector**
  - Hand-tighten only (do not over-torque)
  - Ensure center pin makes contact
- 2. Position antenna for optimal reception**
  - Near window or outdoor mounting
  - Vertical orientation
  - Clear view to sky
- 3. Connect RTL-SDR to USB port**
  - Use USB 2.0 or 3.0 port
  - Direct connection preferred (avoid hubs if possible)
  - Blue LED should illuminate (if your receiver has one)

### STEP 2: INSTALL RTL-SDR DRIVERS

The system uses RTL-SDR drivers that must be installed before first use, as described below.

#### Windows Installation:

- 1. Prepare:** Plug your SDR dongle (e.g., RTL-SDR) into your computer.
- 2. Download:** Download the latest Zadig application from [zadig.akeo.ie](http://zadig.akeo.ie) (version 2.9 recommended).
- 3. Run:** Launch the application (no installation required, just run `zadig.exe`) as Administrator. Just double click `zadig-2.9` to start Zadig.

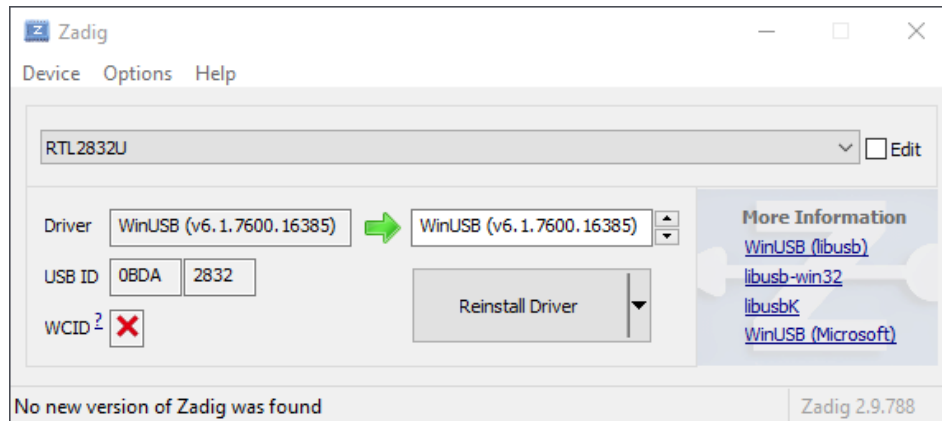

4. List Devices: Go to the "Options" menu and select "List All Devices".
5. Select Device: In the dropdown menu, select your device (e.g., "Bulk Interface 0", "RTL2832U", or "RTL2838UHIDIR").

*Note: Ensure the USB ID matches 0BDA 2838 or 0BDA 2832.*

6. Select Driver: Ensure the box next to the green arrow shows WinUSB.
7. Install/Replace: Click Install Driver (or Reinstall Driver).
8. Repeat: If your device has multiple interfaces, repeat the process for "Bulk Interface 1".
4. Finish: Close Zadig, open OTDAU, load any System configuration and then select GPS/ADS-B for display. System will automatically:
  - Detect and start the best available decoder
  - Begin receiving ADS-B messages
  - Display detected aircraft
5. Initial Setup Time:
  - First aircraft may appear within 30 seconds
  - Full display population: 2-5 minutes
  - Aircraft qualify after receiving sufficient messages

### **Troubleshooting:**

- Wrong Driver: If you accidentally replace the wrong driver (e.g., for a mouse), reinstall that device in Device Manager.
- Windows 10/11: Ignore Windows automatic installation messages when plugging in the device.
- Errors: If it fails, try a different physical USB port.

### **RESTART ADS-B DISPLAY**

The ADS-B receiver is automatically configured and started when you activate the display. If you unplug and then reconnect the SDR or want to change the receiver gain setting, you can restart the driver using ADS-B Gain Settings found under Setup, as shown below.

### **Success Indicators:**

- Message count increasing (shown in display header)
- Aircraft appearing in list
- Position data populated (latitude, longitude, altitude)
- Green signal strength bars
- Yellow and pink highlighted rows indicate data age (time since last message)

Auxiliary Video Display
Fullscreen

### GPS / ADS-B Aircraft Tracker

GPS: 12 sats, HDOP 0.82m | Loc: 34.18964, -118.51055

Messages: 384 | Aircraft: 59 displayed, 86 qualified, 232 total  
OpenSky: OK (59 aircraft) | Sources: 177 RF, 55 OS | 1824 OS queries left today

--- Display aircraft ---

  
Max aircraft in camera FOV  

-
10
+

	SRC	IDENT	SYM	SIG	TYPE	AGE	ALTITUDE	LATITUDE	LONGITUDE	VELOCITY	HEADING	DIST	BEARING
							ft	deg	deg	kts	deg	mi	deg
						sec							
RF	A4E2CE	?				16	2300	34.235100	-118.529900			13.17	286.6
RF	N6170C	L		Light		0	6800	34.361184	-118.642845	94.0	68.9	22.78	303.3
RF	ABE448	?				0	37000	33.848831	-118.518192	482.0	134.5	25.83	207.4
RF	N5554B	L		Light		0	8375	34.622715	-118.542995	105.0	321.2	33.32	338.5
RF	SWA3978	M		Large		0	38000	34.672256	-118.754752	431.0	338.5	42.41	323.3
OS	N533CA	?				5	6450	34.158900	-118.335500	83.4	256.1	2.14	225.0
OS	N5156J	?				5	3400	34.148400	-118.320200	90.1	50.0	2.33	196.0
OS	N557GC	?				5		34.199600	-118.359500		357.2	3.17	294.2
OS	N224LA	?				5	725	34.046100	-118.287700	73.9	66.9	9.39	172.5
OS	N540K	?				5		34.210600	-118.484400		2.8	10.23	281.7
OS	DAL2541	?				1	5300	34.032500	-118.305300	213.0	63.0	10.25	178.8
OS	M208VA	?				5		34.198300	-118.488100		315.0	10.31	276.8
OS	EJA938	?				5		34.197200	-118.488400	0.1	244.7	10.32	278.4
OS	EJA524	?				5		34.208100	-118.487000		272.8	10.35	280.6
OS	N390EA	?				5		34.196600	-118.490200	6.5	146.2	10.41	276.1
OS	N6133D	?				5	700	34.206200	-118.488900	54.2	355.8	10.43	279.7
OS	N182JC	?				5		34.203600	-118.491300		30.9	10.54	278.6
OS	SWA1548	?				1	19775	34.035278	-118.251063	399.7	55.4	10.59	161.7
OS	N618DH	?				5		34.215300	-118.490200		270.0	10.83	283.0

## STEP 5: RTL-SDR GAIN CONFIGURATION (OPTIONAL)

After starting the ADS-B display, you can optimize receiver performance by adjusting the RTL-SDR gain setting:

6. Navigate to **Setup** → **ADS-B Gain Settings**

7. Select gain mode:

- Auto Gain (Recommended) - System optimizes automatically
- Preset Gain - Choose from environment-specific presets
- Manual Gain (Advanced) - Set custom gain value 0-49.6 dB

### Preset Gain Options:

- Maximum Range - Rural (42 dB) - Best for open areas with minimal RF interference
- Suburban / General Use (27 dB) - Balanced setting for most locations
- Urban / High RF (20 dB) - Reduces overload in areas with strong signals
- Very High RF / Near Airport (15 dB) - Prevents receiver saturation near airports

8. Click **Apply & Restart** to apply changes

**Note:** Gain changes require restarting the ADS-B display to take effect. The Apply & Restart button will automatically restart the receiver with the new settings.

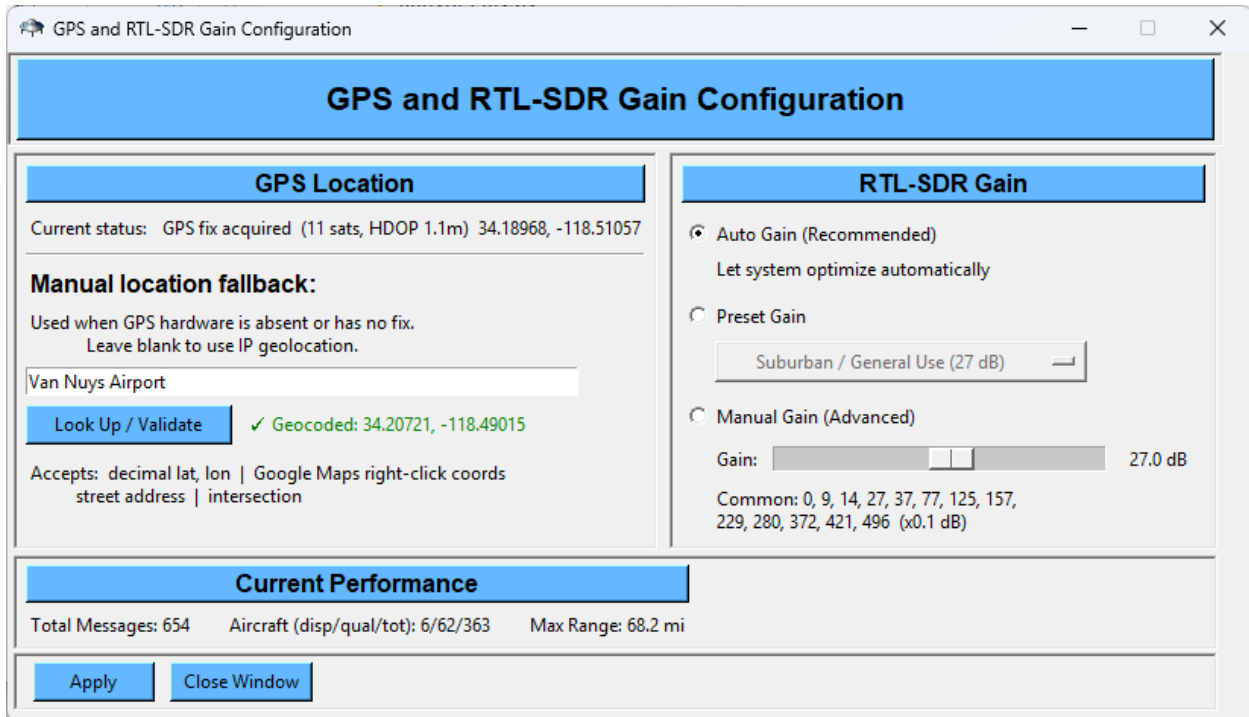

Enter a location and click Look Up / Validate to convert it to latitude/longitude values. These values will be used for the ADS-B location if no GPS hardware is connected or if it is, no fix has been acquired yet.

All GPS and ADS-B options are saved in C:\OTDAU\SystemOptions.txt upon Apply and restored when OTDAU is started.

## GPS/ADS-B Display Interface

### Display Overview

The GPS/ADS-B Display shows real-time aircraft tracking information in a clean, organized format optimized for quick scanning and interpretation.

**Auxiliary Video Display** **Fullscreen**

---

**GPS / ADS-B Aircraft Tracker** **Aircraft display enabled**

GPS: 12 sats, HDOP 0.94m | Loc: 34.18963, -118.51064 Max aircraft in camera FOV

Messages: 1618 | Aircraft: 63 displayed, 114 qualified, 895 total - 10 +

OpenSky: OK (58 aircraft) | Sources: 836 RF, 59 OS | 2787 OS queries left today

SRC	IDENT	SYM	SIG	TYPE	AGE	ALTITUDE	LATITUDE	LONGITUDE	VELOCITY	HEADING	DIST	BEARING
					sec	ft	deg	deg	kts	deg	mi	deg
RF	AC71E4	?			4	33600	34.268220	-118.595295	379.0	337.0	7.27	318.3
RF	ASA621	M		Large	0	32500	34.090297	-118.382320	484.0	149.4	10.05	133.0
RF	KNV4803	M		Large	4	35000	34.293497	-118.344955	480.0	154.8	11.88	52.8
RF	A2F06E	?			8	18850	34.169742	-118.704565	748.0	293.4	22.30	330.3
OS	A98F77	?			4		34.204500	-118.493000	0.8	272.8	1.44	44.4
OS	N450PD	?			4		34.206200	-118.493000		194.1	1.53	41.3
OS	N83SP	?			4		34.206300	-118.492600		16.9	1.55	41.8
OS	N422SN	?			4		34.214600	-118.499900		250.3	1.83	19.6
OS	N252SP	?			4		34.216500	-118.500300	2.5	270.0	1.95	17.6
OS	N8379L	?			5	700	34.213800	-118.491900	12.5	354.4	1.99	32.6
OS	PXT55	?			5		34.210800	-118.485800	0.1	239.1	2.05	44.3
OS	N252AG	?			5		34.210900	-118.485800		267.2	2.05	44.2
OS	N582TM	?			5		34.210500	-118.484700		320.8	2.07	45.8
OS	N40057	?			5		34.219100	-118.492300	4.5	95.8	2.29	27.2
OS	EJA6762	S		Small	1	8325	34.202400	-118.568400	252.0	338.8	3.42	285.0
OS	N93M	?			5	1475	34.243300	-118.493600	139.3	176.3	3.84	14.7
OS	N213PF	?			5	1075	34.211500	-118.596800	60.7	147.1	5.15	287.1
OS	SOW3223	M		Large	5	1175	34.198300	-118.395900	136.0	90.4	6.59	84.7
OS	CAP448	?			5		34.258800	-118.412300	13.0	137.8	7.38	49.6

### Display Components

#### Header Section

##### Top Row - System Title:

- "GPS / ADS-B Aircraft Tracker"
- Toggle Button (upper right): "Display Aircraft"
  - Click to enable/disable aircraft overlays on Primary Video Display
  - Gray = Disabled
  - Green = Enabled

### Second Row - GPS Status:

- GPS Fix Quality: "GPS: Fix OK (N sats)" or error status
- The five display cases are now:

Condition	Example Text	Color
GPS hardware, fix acquired	GPS Fix: 8 sats, HDOP 1.2m   34.18050, - 118.30900	Green
GPS hardware, no fix yet, manual set	GPS: Connected, 4 sats, waiting for fix   Manual Location: 34.18050, -118.30900	Blue
GPS hardware, no fix yet, no manual	GPS: Connected, 4 sats, waiting for fix	Blue
No GPS hardware, manual location set	Manual Location: 34.18050, -118.30900	Purple
No GPS, no manual	GPS: Not connected   No location set	Gray

- HDOP value in meters
- GPS Coordinates: Latitude, Longitude displayed to 5 decimal places
- Source Indicator: "(GPS)" or "(IP Geolocation)"
- Example: "Loc (GPS): 34.18081, -118.30904"

### Fourth Row - Statistics:

- Messages: Total ADS-B messages received
- Aircraft Counts:
  - Displayed: Aircraft shown in list (passed all filters)
  - Qualified: Aircraft meeting minimum criteria
  - Total: All aircraft detected on 1090 MHz
- Example: "Messages: 2456 | Aircraft: 8 displayed, 12 qualified, 68 total"

### Fifth Row – OpenSky (OS) web data ADS-B status:

- OK if connected and total number of aircraft tracked
- Sources: Number of aircraft tracked via RF and via OpenSky
- Number of shared OpenSky queries available left: UFODAP is allowed up to 4000 queries per day, shared among all users. When this number has been used, this message and one on the Status display indicates that status.

**Upper right – Aircraft display selection:**

- Clicking the Aircraft display button enables/disables overlay of symbols on the Primary Video Display indicating aircraft that might be in view.
- Use the – and + buttons to adjust the maximum number of aircraft indicators in view at once to reduce clutter.

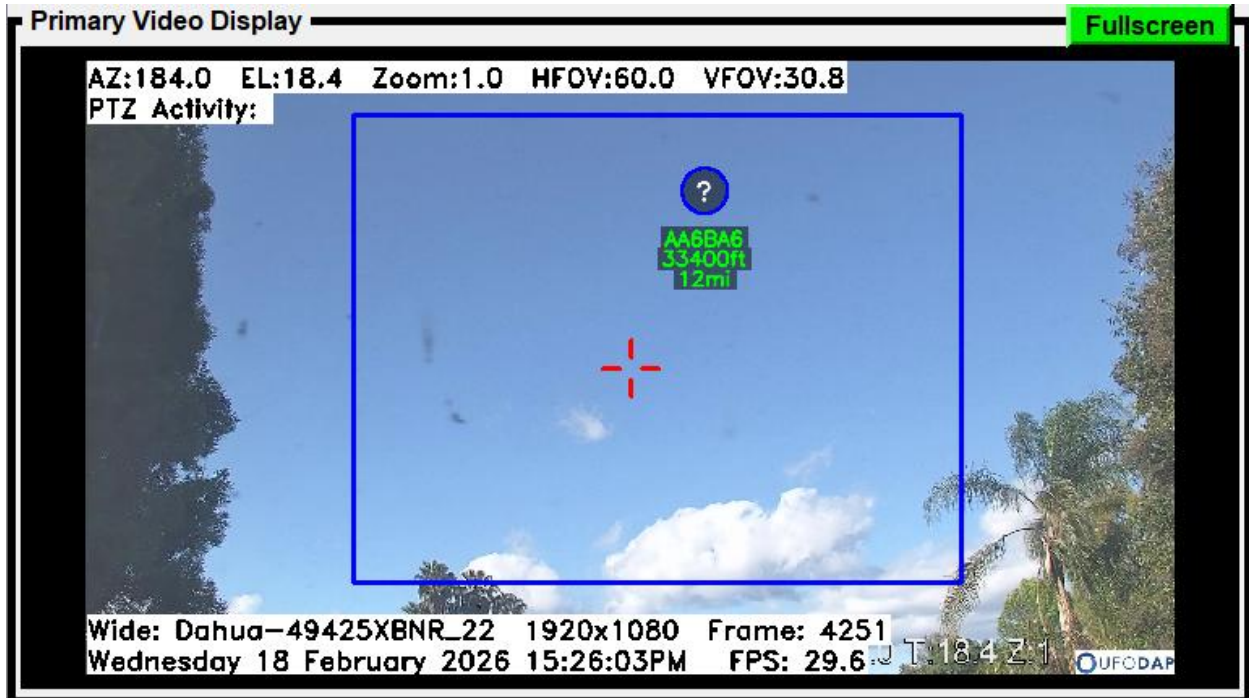

Example of aircraft indicator on wide camera display showing call sign, altitude and distance. The circle around the aircraft type symbol is blue if the data came from RF and red if from OpenSky data.

## Column Headers

The display uses a tabular format with the following columns:

Column	Full Name	Description	Units
IDENT	Identifier	Callsign or ICAO code	Text
SYM	Symbol	Aircraft type code	Letter
SIG	Signal	Reception strength	Bars

TYPE	Aircraft Type	Category description	Text
ALT (ft)	Altitude	Pressure altitude	Feet
LAT (deg)	Latitude	Position latitude	Degrees
LON (deg)	Longitude	Position longitude	Degrees
VEL (kts)	Velocity	Ground speed	Knots
HDG (deg)	Heading	Track direction	Degrees
DIST (mi)	Distance	Distance from observer	Miles
BEARING	Bearing	Angle from your location to the aircraft (your camera's calibrated azimuth angle)	Degrees

### Aircraft Data Rows

Each row represents one aircraft. Rows alternate with white/light gray for readability.

#### IDENT Column:

- Callsign shown if available: "AAL123", "UAL456", "SWA789"
- ICAO code if no callsign: "A2B4C6" (first 6 characters)
- Trailing underscores removed for cleaner display

### **SYM Column (Aircraft Symbol):**

- Single letter indicating aircraft category
- Bold text for better visibility
- Common Symbols:
  - H = Heavy (Boeing 777, A380, B747)
  - M = Medium/Large (Boeing 737, A320, etc.)
  - S = Small (Regional jets, small commercial)
  - L = Light (General aviation, private aircraft)
  - R = Rotorcraft (Helicopters)
  - D = Drone/UAV
  - G = Glider
  - E = Emergency vehicle (medical, police)
  - ? = Unknown type

*[IMAGE PLACEHOLDER: Table showing all aircraft symbols and their meanings]*

### **SIG Column (Signal Strength):**

- Vertical bar graph showing reception quality
- 5 vertical bars possible: |||||
- Green color indicates active signal
- Interpretation:
  - ||||| (5 bars) = Excellent (100+ msgs/min)
  - |||| (4 bars) = Very Good (80-99 msgs/min)
  - ||| (3 bars) = Good (60-79 msgs/min)
  - || (2 bars) = Fair (40-59 msgs/min)
  - | (1 bar) = Weak (20-39 msgs/min)
  - (blank) = Very Weak (<20 msgs/min)

### **Signal Strength Meaning:**

- More bars = closer aircraft or better signal
- Strength decreases with distance
- Weak signals may have intermittent data updates
- Strong signals update position every 1-2 seconds

---

## Aircraft Filtering and Display Criteria

The system applies multiple filters to ensure only valid, relevant aircraft are displayed.

---

### Filter Stages

#### Stage 1: Message Reception

- All 1090 MHz Mode S/ADS-B messages received
- CRC validation performed by external decoder (rtl\_adsb)
- Invalid messages discarded automatically

#### Stage 2: Basic Qualification

- Minimum message count: 8 messages
- Valid data quality score: Combination of factors:
  - Position messages received
  - Callsign decoded
  - Altitude data present
- Requirement: Minimum quality threshold met

#### Stage 3: Position Validation

- Coordinate range check:  $-90^{\circ} \leq \text{Latitude} \leq 90^{\circ}$ ,  $-180^{\circ} \leq \text{Longitude} \leq 180^{\circ}$
- Distance validation: Position must be within 400 miles of observer
  - Rejects CPR (Compact Position Reporting) decoding errors
  - CPR errors can produce positions anywhere on Earth
  - 400-mile limit catches invalid decodings
- Altitude validation:  $0 \leq \text{Altitude} \leq 65,000$  feet
  - Rejects negative altitudes (decoding errors)
  - Rejects unrealistic high altitudes ( $>65,000$  ft)

#### Stage 4: Display Filters

- Position required: Latitude AND Longitude must be present
- Distance limit: Aircraft within 150 miles only
  - Beyond 150 miles: Weak signals, unreliable data
  - Focus on trackable, observable aircraft
- Altitude validity: No negative altitudes displayed

**Result: Only aircraft passing ALL filters appear in display**

## **Understanding Aircraft Counts**

The statistics line shows three different aircraft counts:

Example: "Aircraft: 8 displayed, 12 qualified, 68 total"

### **Total (68):**

- All aircraft detected on 1090 MHz
- Includes Mode S transponders (no position data)
- Includes aircraft with insufficient messages
- Includes aircraft beyond reception range

### **Qualified (12):**

- Met basic qualification criteria:
  - Minimum 8 messages received
  - Quality score threshold met
  - Has callsign OR position data
- May not have complete position data yet

### **Displayed (8):**

- Passed ALL filters:
  - Qualified ✓
  - Valid position (lat/lon) ✓
  - Valid altitude (0-65,000 ft) ✓
  - Within 150 miles ✓
- These are the aircraft shown in the list

### **Why counts differ:**

- Some qualified aircraft don't have position yet (newer Mode S)
- Some qualified aircraft beyond 150 miles (filtered out)
- Some qualified aircraft have invalid altitude (data errors)

## Aircraft Overlay on Wide Video Display

### Overview

The aircraft overlay feature allows real-time aircraft symbols and information to be displayed directly on the wide-angle video feed, showing where each aircraft is located in the sky. Overlays are recorded along with the Wide camera video. An ADS-B derived symbol near a tracked object can help identify it as an actual aircraft and exclude classification as a UAP.

### Requirements:

- GPS receiver providing observer position or OpenSky ADS-B data (but with 10 second sampling interval)
- Wide camera with known azimuth (pan) and elevation (tilt)
- Field of View (FOV) data for wide camera
- ADS-B aircraft with valid position data
- Calibrate/offset the camera FOV and then enable Aircraft displays, as shown below

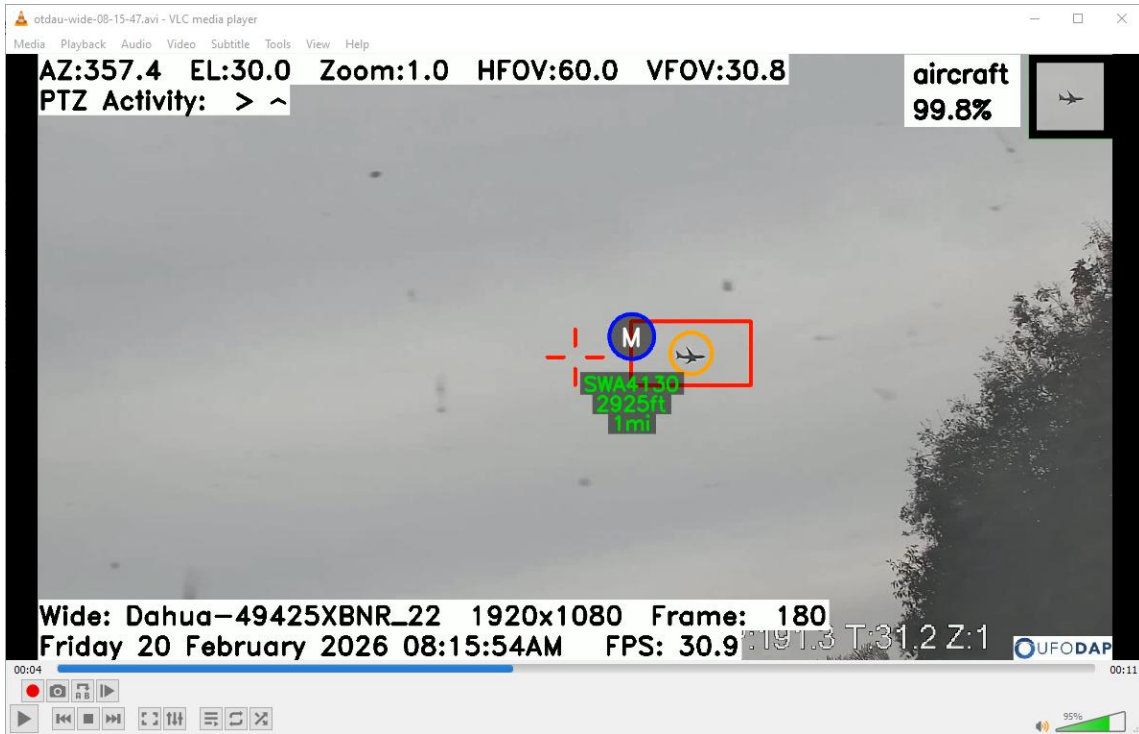

Aircraft icon overlay on video display corresponding to aircraft listed below.

otdau-adsb-08-15-47.avi - VLC media player

Media Playback Audio Video Subtitle Tools View Help

### GPS / ADS-B Aircraft Tracker

GPS: 12 sats, HDOP 0.81m | Loc: 34.18964, -118.51060

Messages: 65515 | Aircraft: 8 displayed, 55 qualified, 666 total

OpenSky: Rate limited (400/day) | Sources: 666 RF, 0 OS | 0 OS queries left today

Aircraft display enabled

Max aircraft in camera FOV:  10

SRC	IDENT	SYM	SIG	TYPE	AGE	ALTITUDE	LATITUDE	LONGITUDE	VELOCITY	HEADING	DIST	BEARING
					sec	ft	deg	deg	kts	deg	mi	deg
RF	SWA4130	M		Large	0	2925	34.199648	-118.510494	180.0	90.3	0.69	0.0
RF	LXJ340	S		Small	0	1725	34.182656	-118.486805	221.0	165.3	1.44	109.6
RF	N620SY	M		Large	0	5525	34.136124	-118.541640	236.0	224.0	4.10	205.7
RF	ABBBA4	?			13	5400	34.188848	-118.674660	227.0	94.5	9.38	269.7
RF	N17FJ	M		Large	9	5150	34.321708	-118.576126	226.0	193.0	9.87	337.7
RF	AA9A56	?			3	21850	34.407411	-118.569775	218.0	321.5	15.42	347.3
RF	SWA1198	M		Large	1	22025	34.412567	-118.586874	354.0	338.6	16.01	344.2
RF	SUAT072	M		Large	19	34300	34.022750	-118.228970	508.0	149.9	19.81	125.5

00:05

---

## Enabling the Aircraft Overlay

### Step 1: Configure Camera PTZ

- Ensure wide camera PTZ (Pan/Tilt/Zoom) is properly configured
- System must know camera azimuth and elevation
- Verify FOV values are correct in camera configuration

### Step 2: Enable Toggle

1. Open Auxiliary Video Display menu
2. Select Option 7: GPS/ADS-B Display
3. Click "--- Display aircraft ---" button (upper right corner)
4. Button turns green with message "Aircraft display enabled"

### Step 3: View Overlays

5. Switch to wide video display (Auxiliary Display Option 1 or Main Display)
  - Aircraft within camera field of view will show available overlays
  - Overlays update in real-time as camera moves or aircraft fly by

### To Disable:

- Click toggle button again (turns gray)
- Overlays removed from video
- Console message: "ADS-B: Wide overlay DISABLED"

---

## Camera Azimuth/Elevation Calibration

For accurate aircraft overlay positioning, the wide camera must be calibrated to establish its azimuth (pan) and elevation (tilt) reference frame.

---

### Calibration Procedure

#### Step 1: Point Camera North and Level

6. Determine True North at your location:
  - Compass points to Magnetic North, not True North
  - Declination correction varies by location
  - Use compass (apply magnetic declination correction)
  - Use a smartphone compass app
  - Use online tools: [magnetic-declination.com](http://magnetic-declination.com)
  - Use North Star (Polaris) at night (very accurate)
  - Compass reading + Declination = True North bearing
7. Position wide camera:
  - Pan camera to point due North ( $0^\circ$ )
  - Tilt camera to horizon ( $0^\circ$  elevation as shown on the Primary Video Display)
  - Use bubble level or smartphone level app to verify horizontal (approximate)
  - Ensure camera stable and locked in position

#### Step 2: Configure PTZ Offsets in OTDAU

8. Open System Configuration window
9. Navigate to: Setup → PTZ Control and Tracking Options
10. Locate "Set pan and tilt offsets" section
11. Click the button "Set P/T offsets"
  - System now knows:
    - Current PTZ position = North ( $0^\circ$  azimuth)
    - Current PTZ position = Horizon ( $0^\circ$  elevation)
    - All future PTZ movements referenced to this baseline
12. Click Save

### Step 3: Position Camera for Data Collection

13. With the System configuration option Enable Pan/Tilt set, manually move the camera to the desired monitoring position.
14. Click Run to collect data.
15. When Stopped, the camera will return to the set position and display the offset AZ and EL values. It will also do this when the Home button is pressed or when that System configuration is reloaded.

## ADS-B Data Logging

### Log File Location

All ADS-B data is automatically logged to a text file for post-mission analysis:

#### Default Location:

```
C:\OTDAU\adbslog.txt
```

#### Directory Creation:

- C:\OTDAU\ directory created automatically by software on first run
- No manual directory creation needed
- If directory missing, software creates it automatically

#### Log File Characteristics:

- Plain text format (readable in any text editor)
- UTF-8 encoding
- Line-buffered (writes immediately, not cached)
- Automatically created on ADS-B startup
- Appends to existing file (preserves historical data)
- Can grow large over time (periodic archiving recommended)

---

## Log File Format

The log uses a timestamped format with structured sections:

### Session Header (Written on startup):

```
[2026-01-13 14:30:00] ===== ADS-B SESSION START =====  
[2026-01-13 14:30:00] Observer Location: 34.18081, -118.30904  
[2026-01-13 14:30:00] GPS Status: Fix OK (8 satellites, HDOP: 1.2)  
[2026-01-13 14:30:00] Decoder: rtl_adsb
```

### GPS Updates (Every 30 seconds):

```
[2026-01-13 14:30:30] GPS Update: 34.18082, -118.30905 | 8 sats | HDOP: 1.1 |  
Alt: 850ft
```

### Aircraft Qualification (Immediate):

```
[2026-01-13 14:31:15] QUALIFIED: AAL123 (A2B4C6) | Pos: 34.2500, -118.2500 |  
Alt: 35000ft | Dist: 10.7mi
```

### Periodic Summary (Every 60 seconds):

```
[2026-01-13 14:32:00] === STATUS: 2456 msgs | 8 displayed, 12 qualified, 68  
total ===  
[2026-01-13 14:32:00] AAL123 H 5bars 35000ft 10.7mi Cruise  
[2026-01-13 14:32:00] UAL456 M 4bars 28000ft 25.3mi Cruise
```

### Session End (On shutdown):

```
[2026-01-13 15:45:00] ===== ADS-B SESSION END =====  
[2026-01-13 15:45:00] Duration: 1h 15m  
[2026-01-13 15:45:00] Total Messages: 15,234  
[2026-01-13 15:45:00] Total Aircraft: 156
```

## Log File Growth

Typical log file growth rates:

Duration	Messages	Aircraft	Approx Size
1 hour	8,000-12,000	50-100	50-100 KB
8 hours	60,000-100,000	200-400	400-800 KB
24 hours	180,000-300,000	600-1200	1.2-2.4 MB

### Log Management Recommendations:

- Archive log weekly in busy areas
- Archive log monthly in rural areas
- Compress old logs (text compresses well)
- Keep most recent session for reference

## GPS TROUBLESHOOTING

Symptom	Diagnosis	Solution
"GPS: Acquiring satellites" >10 min	No GPS fix	Move antenna to window/outdoor
Position jumps around	Poor HDOP, multipath	Relocate away from reflective surfaces
GPS not detected	Not in Device Manager	Try different USB port, check cable
Wrong location shown	Wrong datum/corrupted	Reset GPS, verify WGS84

## Using Test Configurations

OTDAU software is provided with several System and Camera configurations for your use or as a starting point to create your own. This includes several test configurations and the avi video files they reference.

OTDAU will perform all detection, tracking, recording, analysis, etc. operations on test data as if it was from a live, streaming source such as a camera. This is very helpful when developing or testing Tracking options to verify that a similar object will be captured without too many false positives from other in-frame objects such as:

- Birds
- Insects
- Moving foliage
- Twinkling lights such as stars or streetlamps

There are two methods to loading files for test –

### **Select a default avi file:**

1. Click on the System tab and then click “Open configuration”
2. Double click on one of the System configurations that has a file name that begins with “test-”
3. Click Load

### **Select any video file:**

1. Click on the System tab
2. Click “Open a video file for test”; A window will open showing folders and avi files in your Program files (x86)\OTDAU directory.
3. Navigate to any avi file in this directory or anywhere else on your computer.
4. Double click on the selected avi file.

Video files may be one of the following types (dot extensions):

avi, mp4, mov, flv, wmv, mts, dav

Note that the latter method uses all System and Tracking settings as the “test-aerobatics.json” System configuration. Thus, running the selected file will use those settings and modifying those settings will affect subsequent use of the test-aerobatics test configuration.

After the selected configuration or file has been loaded, the first frame of the test avi or mp4 file is displayed, for example:

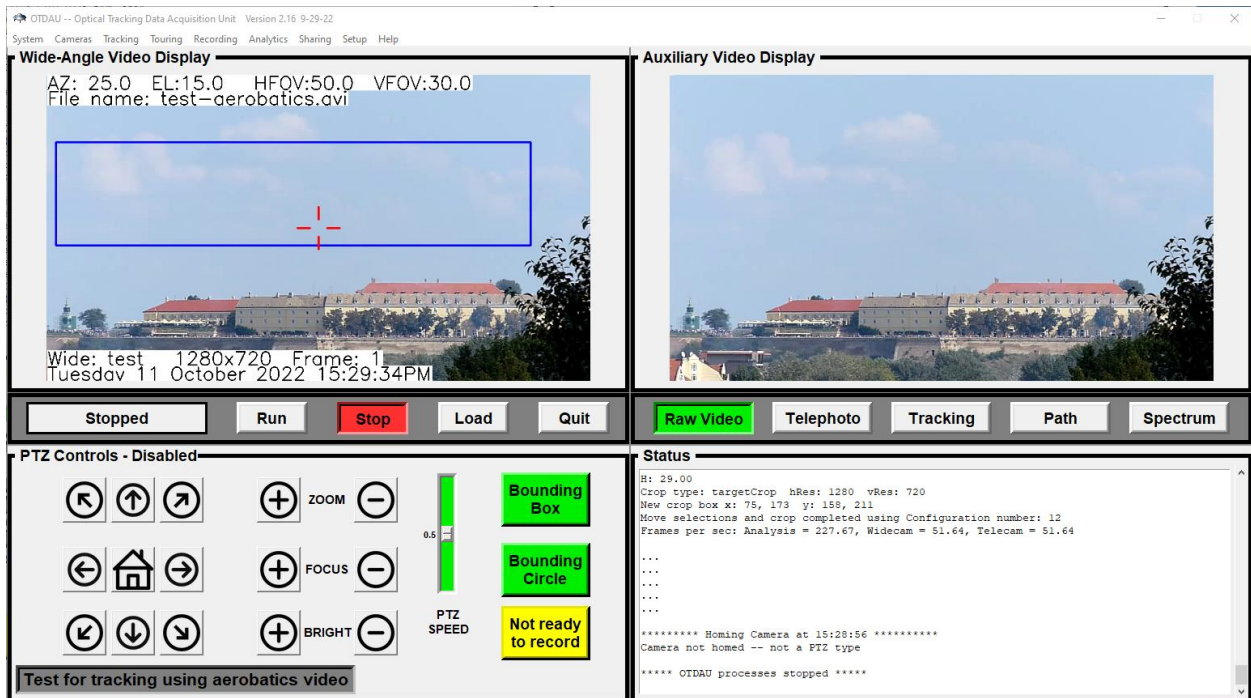

Clicking Run will play back the test avi file and cause OTDAU to detect and track the target object, in this case, an aerobatics stunt plane:

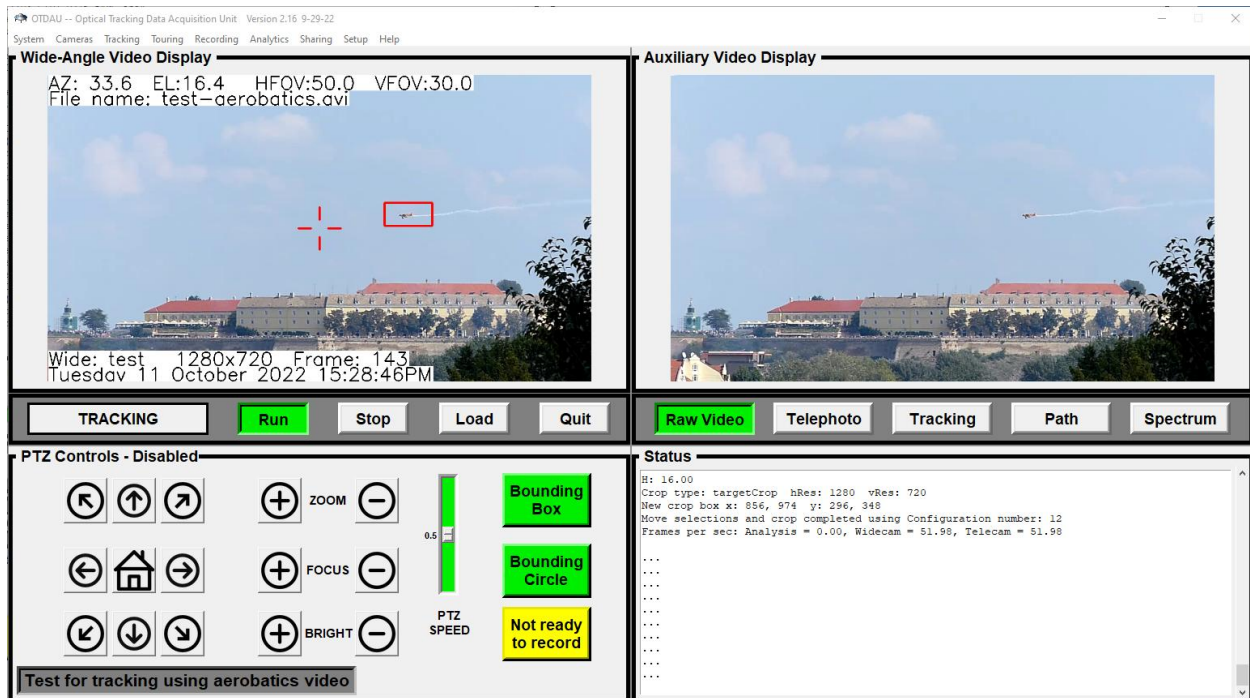

Playback may be stopped at any time by Clicking Stop. It will restart from the first frame when Run is clicked. Playback will automatically restart from frame if the file is allowed to play to its end, as indicated by the Frame number no longer incrementing. Clicking on Stop, then Run will restart playback from frame 1.

Several test configurations are provided so that the user may experiment with settings for different situations, including, for example, a clear night sky with many star-like objects, as shown below.

The ability to select any avi file for testing may be used to improve tracking parameters for existing tracking runs. If you include Wide-Angle video as one of the Recording Options, then select any recorded avi file with a file name beginning with "otdau-aux-". Double clicking that file will load it, ready for a tracking run.

Note that since such file uses the "test-acrobatics" configuration, you may have to change the Bounding Box or Tracking parameters to run the test. You can stop playback, change a parameter and Run again as many times as required.

To better understand what is being tracked, try the Telephoto, Tracking and Path options for the Auxiliary Video Display selection.

## Recorded Folder and file Structure

If OTDAU runs with recording enabled and a target event occurs, then folders and files are created on the Data Path specified above. If the event sequence terminates and it does not meet criteria such as the Event Interval in Tracking Settings, then the data collected will be deleted.

The following defines the data structure that OTDAU creates for a target event –

Top Folder name: <Data Path>

Group Folder name: <SCN> + <today's date> + <folder count>

Data Folder name: <SCN> + <today's date> + <time folder created>

Files of videos and data selected in Recording for the event named:

“otdau-aux” + <time recording started> + “.avi”

“otdau-wide” + <time recording started> + “.avi”

“otdau-data” + <time recording started> + “.csv”

“otdau-tele-frame” + <time recording started> + “.jpg”

<Data Path> as specified in Recording Options

<SCN> System Configuration Name as selected in the System menu

<folder count> initially 0, increments by 1 each time OTDAU begins to Run, creating a new Group Folder name. A new Data folder will be created under this Group folder for each target tracking sequence until either the user Stops the run or the sequence times out per the Maximum time in Tracking Settings.

For example, see the following Windows File Explorer snapshots –

Drive D:\ contains several Top data folders.

D:\UFODAS Data Dahua is selected:

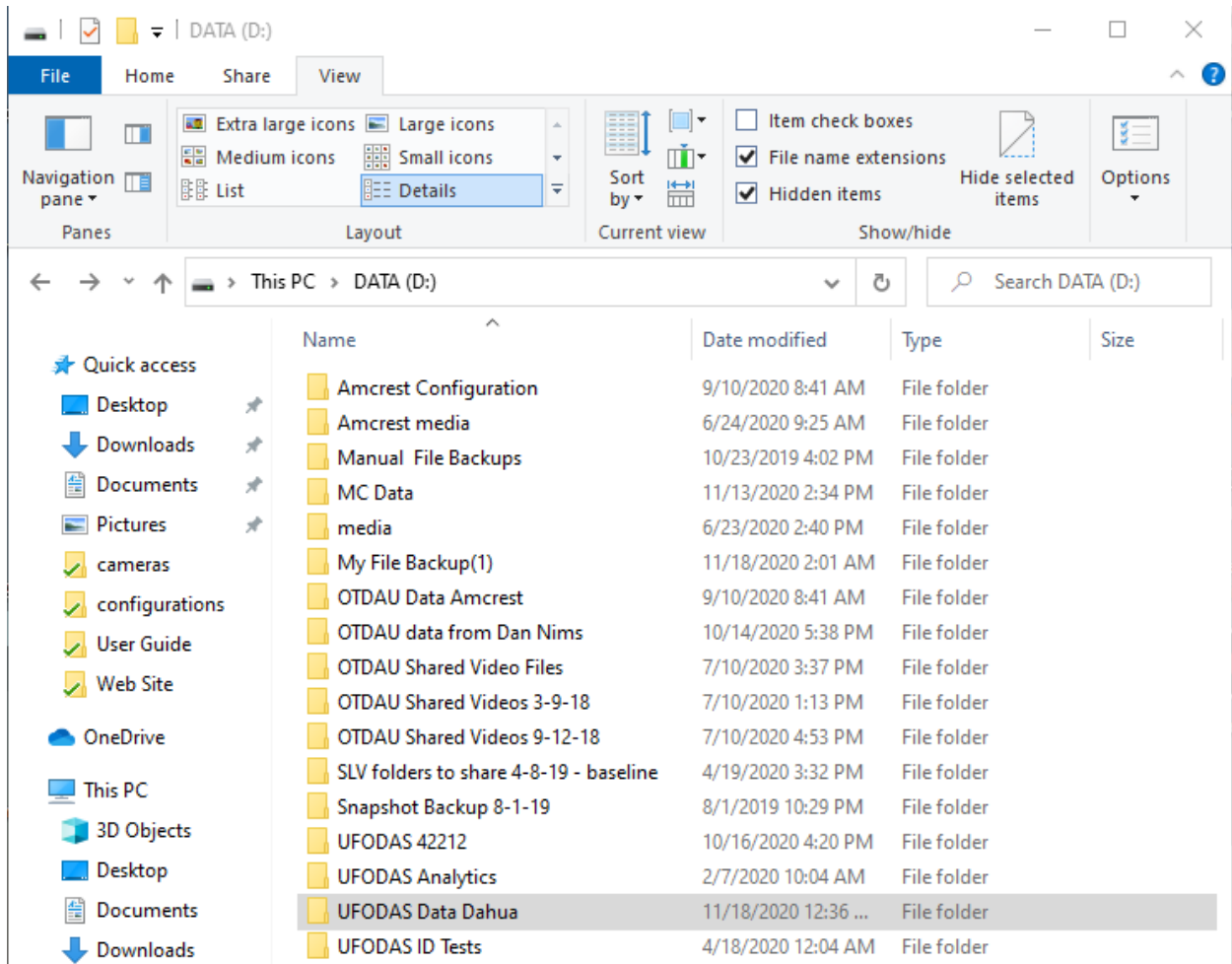

A Group folder under D:\UFODAS Data Dahua (dahua-n51-...) is show below:

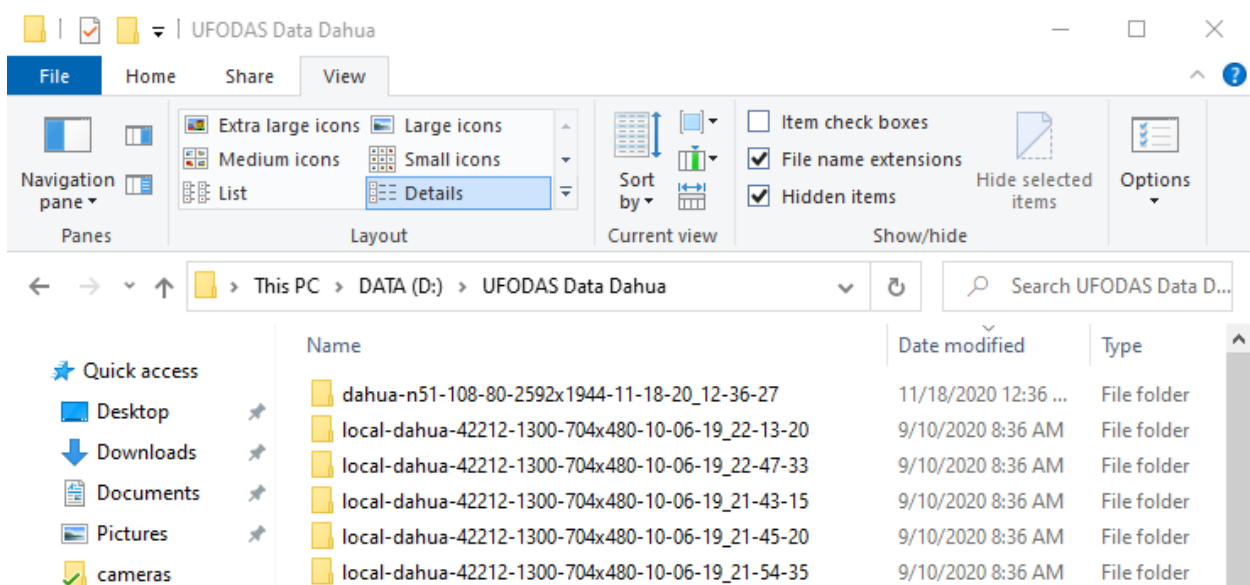

These data folders are under the Group folder. Notice the System and Camera json configuration files:

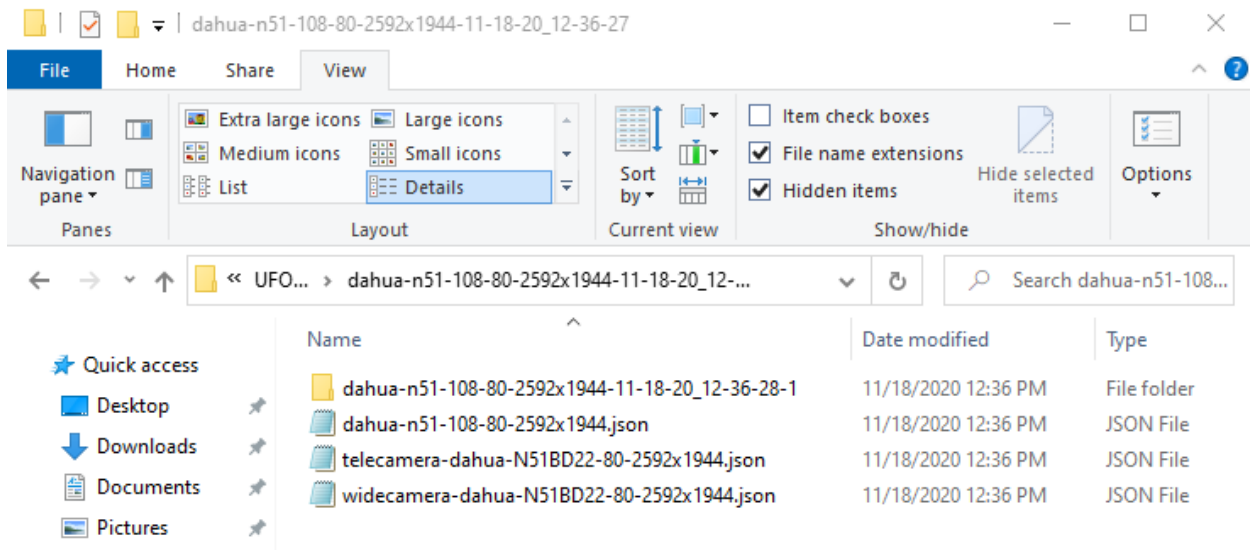

These data files are stored under the first of the above data folders:

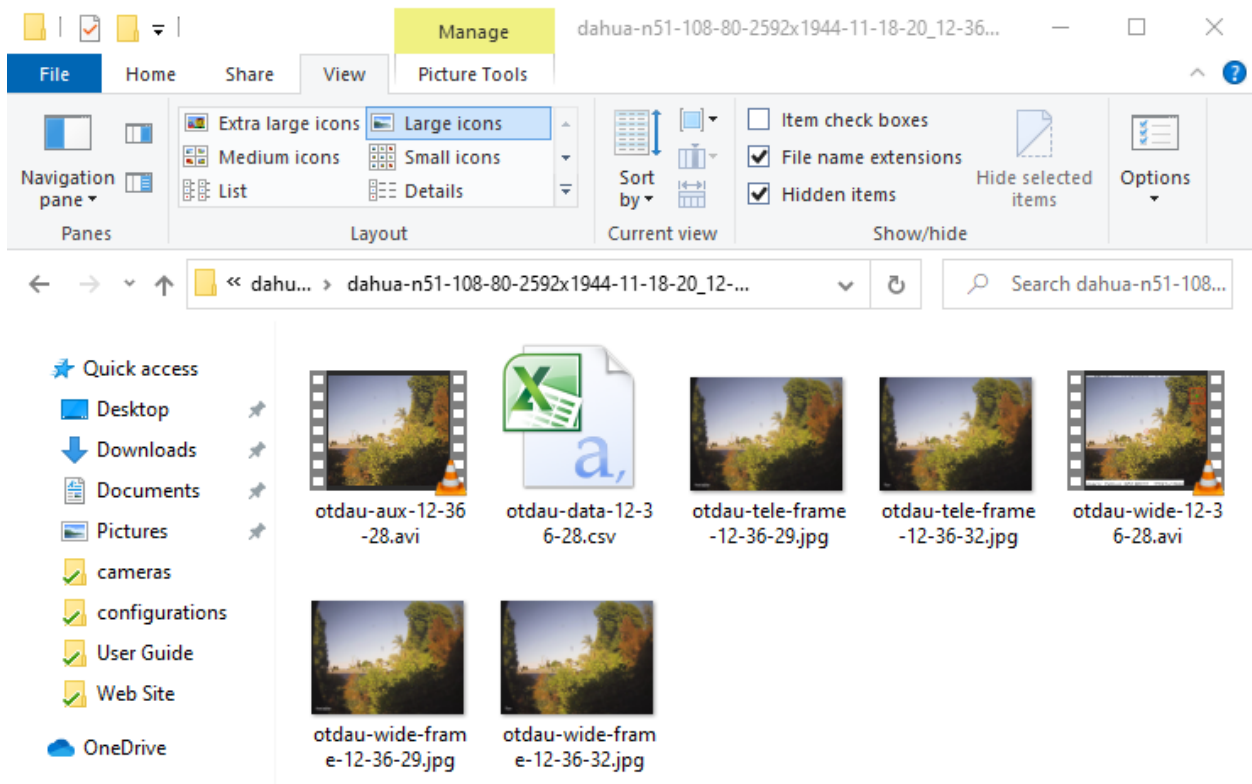

## Program and Configuration File Structure

After installation on a computer, OTDAU software is located in the directory:

C:\Program Files (x86)\OTDAU

Within this folder there are several folders and files that make up the OTDAU software. Among these are the following:

- `otdau.exe` – The operational software file contained in C://OTDAU. Double clicking on this file will run the UFODAS system. The same startup function is also accomplished simply by clicking on the desktop icon created during system installation.
- `configurations` – Contains all of the configuration files that may be selected to configure the system for a particular use. These files may have been given an arbitrary name, typically selected to designate the location of the system and its complement of cameras. Each file must have `.json` as its dot extension.
- `cameras` – Contains a file for each type of camera that is available for system configurations. The file contains a set of parameters that provide the system with a description of hardware features of that camera. Each file must have `.json` as its dot extension.
- `positioners` -- Contains a file for each type of pan/tilt positioning unit that is available for system configurations. The file contains a set of parameters that provide the system with a description of hardware features of that PTU. Each file must have `.json` as its dot extension.

If the user selects a recording option which results in the system collecting data on an acquired target, any such data will be saved in the folder selected in the Recording Options, Data Path entry. If that folder does not exist the first time OTDAU needs to save a recording, then it will be created. The folder may be on any drive and have any name. For example -- C:\My UFO Data.

During operation, other subfolders will be added to the selected folder. Each subfolder will contain data from each target acquisition and tracking instance. Thus, one or more such subfolders may be created during a data collection period (from Run to Stop).

The format of the folder names created consists of the configuration file name appended with the date and time the file was created. For example, if `home-sony` was selected as the configuration file then a typical data folder may be:

C:\<My UFO Data\home-sony-06-09-17\_08-43-00

**TIP:** If you want to save a prior release of OTDAU for future use, despite installing a newly released version, rename C:\Program Files (x86)\OTDAU to something like C:\Program Files (x86)\OTDAU-V2.22 to match the old version. Windows may ask for Administrator permission to do this – reply yes. After doing that, you can install the new version which will be in a new C:\Program Files (x86)\OTDAU folder.

To use the old version, just navigate to the renamed folder and double-click the otdau222.exe file. You can also set the old OTDAU v2.22 desktop icon by right clicking it and selecting browse – Browse to the associated version and change the Properties of the icon so that the old version is the “Target” file and the “Start” folder is the old folder name.

When OTDAU loads and if there is no C:\OTDAU\ConfigFiles folder, then it creates one and copies all System and Camera configuration files from C:\Program Files (x86)\OTDAU to C:\OTDAU\configurations and \cameras. If the ConfigFiles folder does exist, then the only files from Program Files that are copied are those **with names that do not exist in C:\OTDAU\configurations and \cameras** – In this way, new versions of OTDAU can add new configurations and cameras for anyone’s use. Any subsequent loading and changing of System or Camera config files are made to those in the \OTDAU\configurations and \cameras folders. Thus, the user can make any modifications or additions desired, and they will be retained regardless of running OTDAU or new OTDAU version installations.

Within any data folder that was created as named in the Recording menu, there will be a number of files collected during the run. Their filenames are created as follows:

- Wide-angle video: otdau-wide-`<time>`.avi. For example, otdau-wide-08-43-00.avi
- Telephoto video: otdau-tele-`<time>`.avi.
- Still images: An equal number of still frames are collected and named otdau-wide-`<time>`.jpg and otdau-tele-`<time>`.jpg.
- Log file: otdau-logfile-`<date_time>`.txt

All times are 24-hour format.

## pan/tilt Data Acquisition Unit (PTDAU)



The Pan/Tilt Data Acquisition Unit (PTDAU) is a high-performance pan/tilt positioner that can carry up to 10Kg/20lbs and can move up to 100 degrees/sec in pan and 40 degrees/second in tilt. Any PTU defined as a Pan/Tilt Unit Configuration may be used as the Pan/Tilt Unit entry in a System configuration. The PTU is distinct from prior pan/tilt cameras in that it can potentially carry any type of sensor payload, not just cameras.

Standard payloads currently supported for simultaneous operation:

- One or two IP cameras
- One USB camera
- Canon DSLR cameras

With corresponding software revisions, other possible payloads could include:

- EO, thermal IR, ultraviolet or multispectral cameras
- Radar
- Lidar
- Acoustic sensors

The PTDAU configuration provides the means for interfacing such payloads via both PoE and USB as well as onboard data processing and control.

The PTU is available in two versions –

- PTDAU -- PoE power and both Ethernet and USB communications interfaces
- PTUSB -- 120VAC power, USB control interface with PoE camera interface

**The PTDAU version is required for support of USB or DSLR cameras.**

Both versions share the same Pan/Tilt Positioning mechanism which has the following specifications:

- Maximum top load capacity 10kgs/20.05lb
- Pan angle: 0-360°; Tilt angle: -90°~+40°
- Pan speed 0.01~100°/s; Tilt speed 0.01~40°/s
- Preset accuracy:  $\pm 0.1^\circ$
- High precision stepper motor and tilt worm gear drive
- Pan speed up to 100°/s, Tilt speed up to 40°/s
- Support coordinate feedback and control
- 4000V lightning surge protection
- Rated IP66 for dust and water ingress

The PoE version includes an onboard Raspberry Pi 4 Model B 64-bit computer with 2GB RAM and 32Gb SD card for local control and signal processing including IP to Pan/Tilt control via the Pelco-D interface standard, internally, over RS-485 serial.

The Pan/Tilt Unit Configurations define the interface characteristics and driver combinations for specific PTU hardware. For example, the “ptudau” configuration is for a PTDAU and provides the IP address information needed for that interface. The “ptusb” configuration is for a PTUSB and provides the COM port settings needed for that interface.

System configurations that use a PTDAU should use the “ptudau” designation as the Pan/Tilt Unit in its System configuration.

A System configuration that uses a PTUSB should use the “ptusb” designation as the Pan/Tilt Unit in its System configuration.

The AC powered version includes an external USB interface for direct connection to the computer running OTDAU. The length limitation of USB can be extended via CAT5/6 cable using the included converter and up to 150ft of Ethernet cable.

Both versions include a mount on top for a DSLR camera and camera power via a high-current 5V USB connector. The PoE version also includes USB signal interface connectors which may be used for future camera control options. The DSLR camera interface to the PC running OTDAU is by WiFi between the camera and a WiFi router. OTDAU can stream camera video to the OTDAU and, like any other camera, use it for tracking, record it, etc. However, the frame rate is rather low (~4FPS) and the resolution is only 480x320. This is intended only for checkout of camera operation – More effective data collection would be by still frames saved to camera memory by automatic shutter releases by OTDAU during tracking.

OTDAU recording options provide for shutter control at a periodic rate or continuous video recording. In both cases, camera frames or video is stored in the camera’s SD card rather than streaming or uploading to OTDAU. The SD card can be removed from the camera for data retrieval after recording. Alternatively, camera control and data uploading may be accomplished by the Canon phone app, “Camera Connect”.

---

## PTU Payloads

Both the PTDAU and the PTUSB include a camera mounting plate on the top, between the tilt head and the upper controls junction box.

The plate has two sets of M4 threaded holes, one set on each side. The holes are spaced for common circular and square camera mounting bases. A cable gland for camera cable access to the junction box is provided on each side of the box.

Cameras that may be mounted on the plate include:

- Lumanys N5B-4CA2 4MP bullet
- Lumanys N5B-8CA2 8MP bullet
- Uniview TIC2A32SA-F3-4F4AC-I1 hybrid thermal & optical bi-spectrum network bullet
- Uniview TIC2A32SA-F10-4F8AC-I1 hybrid thermal & optical bi-spectrum network bullet

Cameras ordered for use with a PTU will be installed and cabled prior to delivery of the PTU.

The top of the upper junction box of both types of PTU has a detachable DSLR camera mounting device.

---

## AC Version Function Description

This version consists of the pan/tilt positioning mechanism mounted on a junction box.

The junction box houses weatherproof USB, Ethernet and AC power connectors and a push-ON, push-OFF power switch. It also includes a 120VAC, 50/60Hz to 24DC power converter and a USB to RS-485 converter. 24VDC powers the mechanism. The RS-485 signals provide the Pelco-D protocol signals to control pan/tilt speed and direction as well as absolute positioning. It also feeds back real-time pan/tilt position for closed loop tracking control.

The top, tilt portion of the mechanism includes mounting holes for a user's mechanical assembly of cameras or other sensors. An umbilical cable is also provided which communicates power/signals via slip rings to the base. This cable includes 24VDC, 12VDC, RS-485 signals and an Ethernet RJ45 connection. A single PoE camera may be used with its PoE connected to this cable and available at the base via the base PoE connector. The interface could be extended to multiple IP cameras if a PoE extender was included in the top assembly (as is the case with the PTDAU).

The base junction box is mounted on a plate providing a rugged 5/8-11 threaded and padded mount for use with a heavy-duty, surveying-type tripod.

---

## PT Unit Connectors

The lower junction box is shown below, left to right: power switch/indicator, AC power connector, USB connector and PoE connector as well as a Gore vent on the rear:



Inclusion of these four items varies with the ordered configuration:

### **PTDAU (PoE powered and IP interface)**

- Power button
- Waterproof PoE connector

### **PTDAU (AC powered and USB control interface + PoE camera interface)**

- Power button
- Waterproof AC power connector with line cord
- Waterproof USB connector and cable
- Waterproof PoE connector

---

## PoE PTDAU Functional Description

This version consists of the pan/tilt positioning mechanism mounted on a junction box and a second, fan-cooled enclosure on a plate mounted on the top, tilt mechanism.

The base junction box houses weatherproof USB and Ethernet and a push-ON, push-OFF power switch. It also includes a PoE signal splitter / PoE to 24V converter. It also houses a USB to RS-485 converter. 24VDC from the converter powers the mechanism. Thus, either PoE/Ethernet or RS-485 signals via USB provide the means for Pelco-D protocol signals to control pan/tilt speed and direction as well as absolute positioning. It also feeds back real-time pan/tilt position for closed loop tracking control.

The top junction box houses a PoE splitter with four ports. Typically, two ports are used to power and communicate with two PoE IP cameras, one mounted on either side of the top payload plate. Another port provides power and signal to the Raspberry Pi computer. One of the Pi's USB ports is used to communicate with the pan/tilt unit via a USB to RS-485 converter. Another USB port provides an interface to a GPS receiver. A third port is connected to an external connector for DSLR camera or other sensor communication. A second USB connector provides power for a Canon DSLR battery substitute for long-term, battery-less uptime.

The upper payload plate is designed for mounting up to two typical three-hole, circular mount IP cameras. The PTU umbilical cable as well as these camera cables enter the enclosure via waterproof gland nuts. The camera's own angle adjustment feature is used to point at 90 degrees from the mount, under the plate so that the center of gravity of the cameras puts less force on the tilt axis.

The base junction box is mounted on a plate providing a rugged 5/8-11 threaded and padded mount for use with a heavy-duty, surveying-type tripod.

Indicators and connectors on the upper box are shown below. They include waterproof dual USB port connectors and a single USB connector used to provide higher current 5V power for DSLR camera power (without USB signals).

Two LED indicators show when the PTDAU has established a communication path to the PC/OTDAU (COMM) and when control commands are received (CONTROL).

The rear of the box includes a small fan and air input and output cleanable dust filters.  
**NOTE:** The need for air circulation precludes this configuration from being waterproof.



A block diagram showing the components and interconnections of a PTDAU is shown below.

## Pan/Tilt Data Acquisition Unit (PTDAU) Electronics Block Diagram

1/6/2026

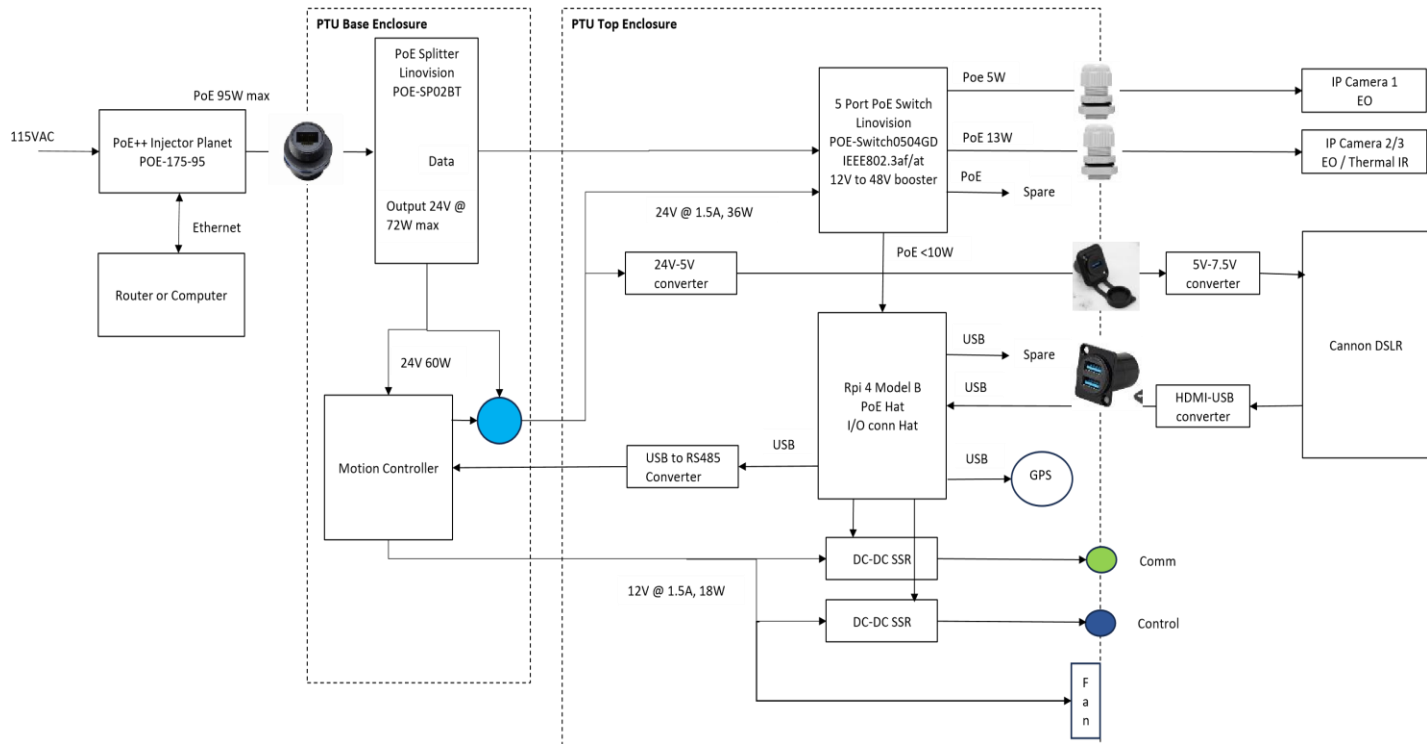

### PTUSB Functional Description

This version consists of the pan/tilt positioning mechanism mounted on a junction box and a second, sealed enclosure on a plate mounted on the top, tilt mechanism.

Differences from the PTDAU are:

- AC powered by a waterproof line cord and connector
- Motion control by USB commands
- Control and data to/from up to three IP cameras directly by PoE via splitter/switch in the top enclosure

- DSLR control only via WiFi
- Comm indicator showing USB/RS-485 activity

A block diagram showing the components and interconnections of a PTUSB is shown below.

Pan/Tilt Data Acquisition Unit (PTUSB) Electronics Block Diagram

1/6/2026

Pan/Tilt Data Acquisition Unit (PTUSB) Electronics Block Diagram

1/6/2026

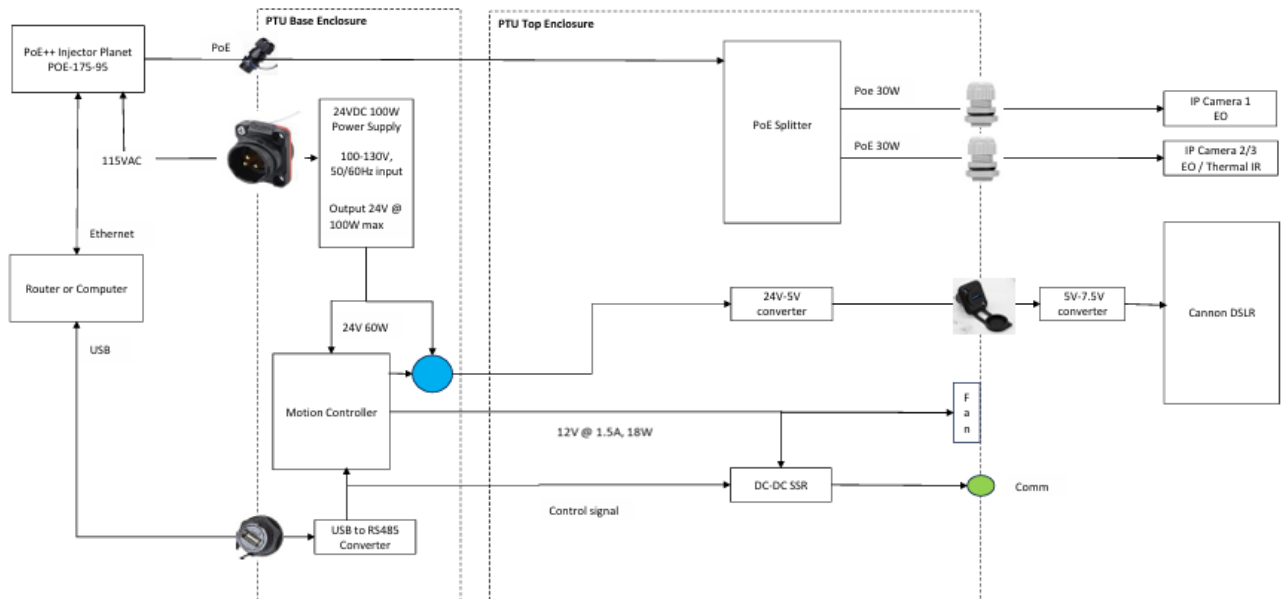

## PTDAU Operation

A typical PTU configuration for USB control is shown below:

The screenshot shows the 'Pan/Tilt Unit Configuration' dialog box in the OTDAU software. The window title is 'OTDAU -- Optical Tracking Data Acquisition Unit Version 2.26Beta 5-31-25'. The dialog is divided into several sections:

- Header:** 'Pan/Tilt Unit Configuration' in a blue bar.
- General Settings:** 'Pan/Tilt type' is set to 'PTU' and 'Pan/Tilt Driver' is 'ptuusb'. The 'Filename' is 'C:/Users/rholc/Documents/UFODAS/System-Software/otdau-build/positioners/ptuusb.json'. There are three checkboxes: 'Enable PT' (checked), 'Reverse absolute move' (unchecked), and 'Reverse continuous move' (checked).
- USB Interface Fields:** A section titled 'To use the USB driver, enter the following USB Interface fields'. It includes: 'COM Port' (COM1 thru COM4) set to 'COM3', 'Baud Rate' (2400, 4800, 9600 or 19200) set to '9600', 'Data Bits' (5-8) set to '8', 'Stop Bits' (1 or 2) set to '1', and 'Parity' (E, M, N, O or S) set to 'N'.
- IP Interface Fields:** A section titled 'To use the IP driver, enter the following IP Interface fields'. It includes: 'IP Address', 'HTTP Port', 'User', and 'Password' (all empty).
- Realtime data received from the PTDAU:** Includes: 'Time', 'Satellites' (0), 'Longitude', 'Latitude', and 'Altitude' (0.0).
- Proportional Constant:** A slider set to 30.
- Integral constant:** A slider set to 0.0.
- Derivative constant:** A slider set to 0.0.
- Buttons:** 'Open', 'Save', 'Save As', 'Close File', and 'Close Window'.

To set up a PTDAU for USB control

A typical PTU configuration for IP control is shown below:

OTDAU -- Optical Tracking Data Acquisition Unit Version 2.26Beta 5-31-25

### Pan/Tilt Unit Configuration

Pan/Tilt type  Pan/Tilt Driver

Filename

Enable PT  Reverse absolute move  Reverse continuous move

To use the USB driver, enter the following USB Interface fields

COM Port  Baud Rate   
COM1 thru COM4 2400, 4800, 9600 or 19200

Data Bits  Stop Bits  Parity   
5-8 1 or 2 E, M, N, O or S

To use the IP driver, enter the following IP Interface fields

IP Address  HTTP Port  User  Password

Realtime data received from the PTDAU

Time  Satellites  Longitude  Latitude  Altitude

Proportional Constant

Integral constant  Derivative constant

To set up a PTDAU for USB control

## PTDAU Software boot process

There may be periodic updates of PTDAU software to add or change features or correct bugs. A PTDAU might be mounted in a location that would make it difficult to implement these changes if it were necessary for the user to access its enclosure directly.

Therefore, part of the Ethernet communication protocols between the PTDAU and OTDAU software implement a means for remote reloading of PTDAU software and rebooting the PTDAU processor to run it.

PTDAU software updates are included with each OTDAU release. The user does not need to take any special action to install an update on an PTDAU – this is accomplished automatically the first time a System configuration is loaded with a PTDAU included if the PTDAU has a version prior to the new one. When this happens, the user will note a longer than normal Load time and status messages will indicate this process in progress. If the System is closed and another one loaded with the same PTDAU, then that PTDAU will not be reloaded again.

The rebooting process consists of the following processes:

1. When a PTDAU is powered up (its Ethernet cable is plugged into an active injector) it starts running the version of software last downloaded to it. The display indicates the software version running as in step 4, below. It samples its internal sensors even if OTDAU is not running. Normal operation is indicated by the green COMM indicator flashing periodically.
2. When an instance of OTDAU first establishes communications with an PTDAU, it uploads the current PTDAU software version and compares it to that of the version included with the last MC release. If the new version is higher than the existing version, MC downloads the new version to the MSDAU and commands the PTDAU to reboot. After the PTDAU reboots, it automatically runs the PTDAU software.
3. The PTDAU starts running, communicating data to the OTDAU, the blue CONTROL LED indicates the PTDAU's ONLINE status.

If the OTDAU is closed or communication is otherwise lost, the PTDAU continues to sample data while checking for a new connection. Communication with the OTDAU will be automatically resumed when OTDAU is restarted, and a System that uses the PTDAU is loaded.

## MultiSensor Data Acquisition Unit (MSDAU)

### Introduction

The MultiSensor Data Acquisition Unit (MSDAU) hardware consists of a waterproof enclosure containing a small computer (Raspberry Pi) and a collection of sensors on a second board mounted on top of the Pi. The sensor board and its specifications are described below. Power over Ethernet (PoE) and bi-directional communications are provided via an external waterproof RJ45 connector. Two other waterproof connectors provide two external USB interfaces. An SMA RF antenna connector provides signal for the internal Software-Defined Radio (SDR) that generates RF spectrum data.



The MSDAU also includes an internal GPS receiver and provides two waterproof USB connectors for external equipment interfaces.

A block diagram of the MSDAU is shown below. Note that power and communication to an OTDAU or MS is accomplished by a single Ethernet cable.

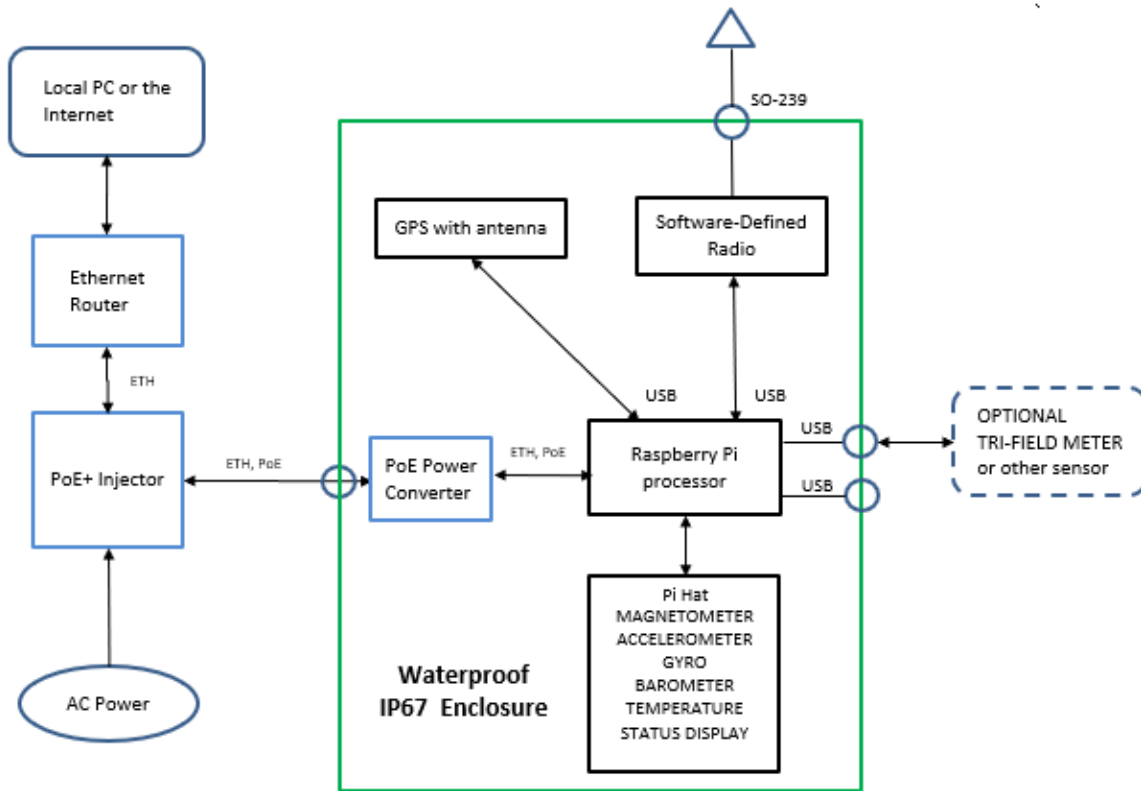

○ Indicates enclosure-mounted waterproof connector

The Pi has four USB ports of which two are available externally; one is used for the internal GPS receiver and one for the SDR.

Cameras and associated MSDAUs do not have to be in proximity. The MSDAU is not the camera processor or controller – the OTDAU software does that job. Camera control via MSDAU may be a subject of future development.

When using two nearby cameras for triangulation, each camera is connected (locally or over the Internet) to a separate instance of the OTDAU software. So, for example, two cameras may be on separate tripod mounts and either or both may share that mount with an MSDAU. The distance between them is only limited by cable length.

Practically, close cameras, less than one meter apart, can be used for triangulation but

the farther apart they are, the more accurate the position and altitude measurements. Triangulation is accomplished by MC software on the same computer or a computer at some other location.

An MSDAU may be mounted to a System mounting bracket that provides a tripod mount and optionally share that mount with a camera. An MSDAU may also be poll or building corner mounted using an adapter bracket with the rear System Mounting plate. See the UFODAS System Installation Guide for details.

## Description and Specifications

The MSDAU is housed in a non-metallic enclosure, sealed when closed to IP66 and NEMA 1, 2, 4 and 4x specifications.

- External size: 8.27in (210mm) long by 6. in (160mm) wide by 3.94in (100mm) deep
- Gore vent for internal/external pressure equalization without condensation
- Waterproof connectors for Ethernet and two for USB
- Pi Sense Hat with 15 sensors, 8x8 multi-color display and joystick
- Internal GPS receiver with SiRF Star IV GPS Chipset
- Internal SDR receiver with frequency range of 25MHz to 1750MHz or 6000MHz
- Clear cover for display and indicator visibility while sealed
- Power: <4W
- Temperature range: 0 to 50 degrees C internal; external could be lower

The MSDAU implements several sensing functions by means of an add-on board for the Raspberry Pi computer, made especially for the Astro Pi mission known as the Sense HAT. This combination, shown below, was packaged for use in the International Space Station in December 2015 – and is now available for general use.

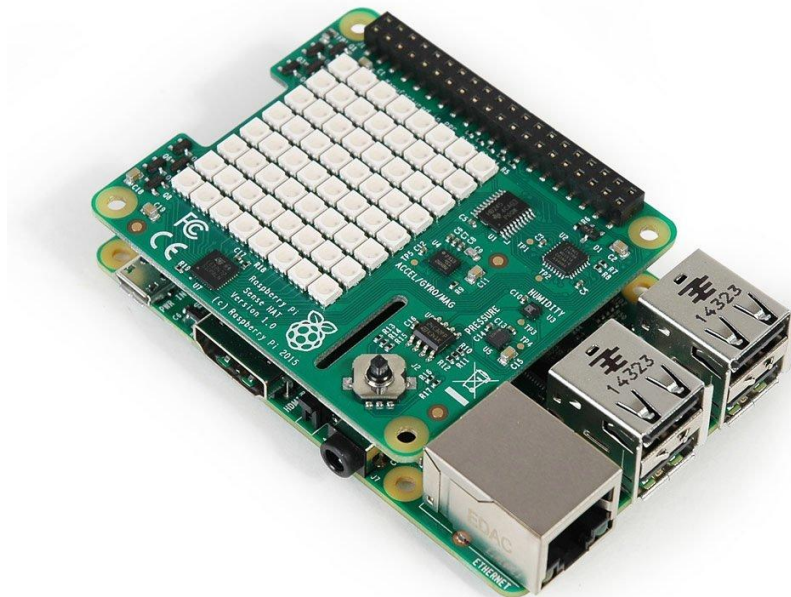

The Sense HAT has an 8×8 RGB LED matrix, a five-button joystick and includes the following sensors:

- Gyroscope - angular rate sensor: +/-245/500/2000dps
- Accelerometer - Linear acceleration sensor: +/-2/4/8/16 g
- Magnetometer - Magnetic Sensor: +/- 4/8/12/16 Gauss
- Barometer: 260 - 1260 hPa absolute range (accuracy depends on the temperature and pressure, +/- 0.1 hPa under normal conditions)
- Temperature sensor (Temperature accurate to +/- 2 degrees C in the 0-65 degrees C range)
- Relative Humidity sensor (accurate to +/- 4.5% in the 20-80%rH range, accurate to +/- 0.5 degrees C in 15-40 degrees C range)

The board is compatible with the Raspberry Pi B+, A+, Pi 2, 3 and 4. The MSDAU uses the latest Pi 4 Model B with 2GB of memory. In the ASTRO PI, the Raspberry Pi Sense HAT is being used by the Raspberry Pi Foundation to perform science experiments aboard the International Space Station (ISS). For more information see Appendix A on the first page of each data sheet:

**Inertial measurement sensor: ST LSM9DS1**

A 3D accelerometer, 3D gyroscope and 3D magnetometer combined in one chip. It will give you the [pitch, roll and yaw](#) orientation of the Astro Pi and therefore the ISS itself. It can also be used to detect when the ISS booster rockets are being fired or just as a compass to find the direction of North.

**Barometric pressure and temperature sensor: ST LPS25H**

Provides measurement of air pressure in Pascals or Millibars as well as the temperature in centigrade.

**Relative humidity and temperature sensor: ST HTS221**

Measures percentage of relative humidity as well as the temperature in centigrade. The sensor is good enough to detect the water vapor in human breath.

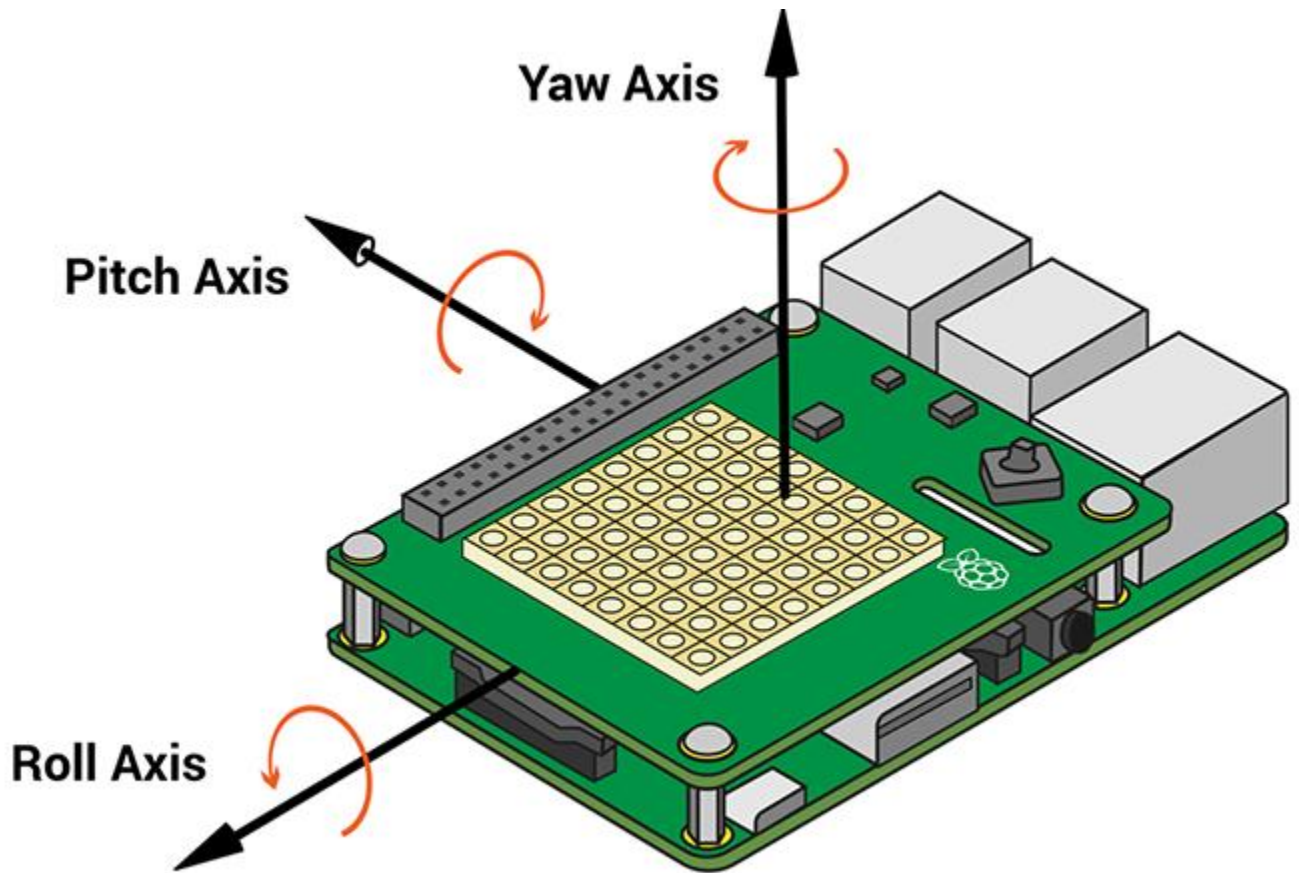

Above picture shows the axes of motion as measured in the Sense HAT.

The MSDAU also includes a GPS receiver and antenna that provides MSDAU/camera location, altitude and time to the associated MC.

Bear in mind that since the Sense HAT board inside the enclosure, measurements of temperature and humidity reflect its local conditions, not the surrounding atmospheric environment.

## Display and Indicators

The MSDAU includes an 8 x 8 color LED display visible through the clear cover when the enclosure is closed and thus environmentally sealed.

This display provides an indication of the status of MSDAU operations. The display may be:

- Scrolling software version number in green upon bootup
- A temporary static display indicates that the software update and reboot process has begun.
- Flashing concentric green boxes -- The MSDAU is sending data to an MC. If these boxes change to red then the value of at least one sensor has exceeded the user-specified change threshold, causing a trigger condition.
- Various status text messages during use of the joystick for MSDAU setup

The trigger threshold is specified in the MC Sensors > MSDAU menu for each selected MSDAU configuration.

## Joystick settings

Press the center of the joystick button –

Scrolls “Bx” and displays “x” where x is the current brightness value

Note that brightness 0 will disable the display during normal operation and will be initially 2 when the joystick is used again.

Moving the joystick right or left selects which value to change –

Scrolls “.x” and then displays “x” for the third number in the IP address

Scrolls “.abc” and then display “c” for the fourth number in the IP address

Where the IP address is 192.168.x.abc

Moving the joystick up or down increments or decreases the value. The new value is displayed.

Joystick center button will display the final selection and then go back to normal operation. If any part of the IP address was changed, then the MSDAU will restart.

- Gamma correction is utilized to provide a non-linear relationship between the illumination value and the perceived brightness – 1 is very low and 5 is very bright. Setting this value to 0 turns the display off. As the joystick is moved left or right, the selected illumination level is displayed at the corresponding level to provide an idea of how bright the display will be.
- The IP address and illumination level are retained through MSDAU power cycles.
- The red and green LED indicators on the Pi CPU board indicate power ON and solid-state disk access, respectively.

## Software boot process

There may be periodic updates of MSDAU software to add or change features or correct bugs. An MSDAU is often mounted in a location that would make it difficult to implement these changes if it were necessary for the user to access its enclosure directly. Therefore, part of the Ethernet communication protocols between the MSDAU and Mission Control (MC) software implement a means for remote reloading of MSDAU software and rebooting the MSDAU to run it.

MSDAU software updates are included with each MC release. The user does not need to take any special action to install an update on an MSDAU – this is accomplished automatically the first time a Mission is loaded on MC with an MSDAU included as one of its DAUs. When this happens, the user will note a longer than normal Load time and status messages will indicate this process in progress. If a Mission is closed and another one loaded with the same MSDAU, then that MSDAU will not be reloaded again.

The rebooting process consists of the following processes:

4. When an MSDAU is powered up (its Ethernet cable is plugged into an active injector) it starts running the version of software last downloaded to it. The display indicates the software version running as in step 4, below. It samples its internal sensors even if no MC is running. Normal operation is indicated by green concentric squares on the display.
5. When MC first establishes communications with an MSDAU, it uploads the current MSDAU software version and compares it to that of the version included with the last MC release. If the new version is higher than the existing version, MC downloads the new version to the MSDAU and commands the MSDAU to reboot. After the MSDAU reboots, it automatically runs the MSDAU software.
6. The MSDAU starts running, communicating data to the MC which indicates the MSDAU's ONLINE status.

If the MC is closed or communication is otherwise lost, the MSDAU continues to sample data while checking for a new connection. Communication with the MC will be automatically resumed when the MC is restarted, and a Mission is loaded.

**NOTE:** MSDAU firmware will be upgraded automatically during Load when the detected version in any loaded MSDAU is different from the current version which is included in the latest MC revision.

## Appendix A: ADS-B Aircraft Tracking Supplement

### Understanding ADS-B Reception

ADS-B (Automatic Dependent Surveillance-Broadcast) is a surveillance technology where aircraft broadcast their position, velocity, and identification. UFODAS uses two complementary data sources for comprehensive aircraft tracking:

---

#### Dual Data Sources

##### **RF (Radio Frequency):**

- Direct reception from aircraft via RTL-SDR dongle

- Real-time local aircraft detection at 1090 MHz

- Range: 10-150 miles (depends on antenna, altitude, terrain)

##### **OS (OpenSky Network):**

- Internet-based global aircraft data from OpenSky Network API

- Pre-filtered, high-quality data with aircraft type information

- Worldwide coverage, 10-second update interval

## Performance Expectations

### Typical RF Reception Performance

Environment	Aircraft Visible	Messages/Min
Urban/Suburban	3-15	50-200
Rural	1-5	20-100
Coastal/Flat	5-20	100-300

### Message Accumulation Patterns

#### Close Aircraft (0-20 miles):

10-50+ messages accumulate

Strong signal (5 bars)

All data fields populated - DISPLAYED ✓

#### Medium Distance (20-40 miles):

3-10 messages accumulate

Medium signal (2-4 bars)

Most data fields populated - DISPLAYED ✓

#### Edge of Range (40-60+ miles):

1-2 messages only

Weak/no signal bars

Limited data - NOT DISPLAYED (normal filtering)

## Tracker Table Reference

### Column Descriptions

Column	Unit	Description
SRC	-	Data source: RF (radio) or OS (OpenSky network)
IDENT	-	Aircraft callsign or ICAO hex address
SYM	-	Aircraft symbol/icon
SIG	-	Signal strength bars (RF only, 1-5 bars)
TYPE	-	Aircraft type code (B738, A320, C172, etc.)
AGE	sec	Seconds since last update
ALTITUDE	ft	Altitude above mean sea level
LATITUDE	deg	Latitude (decimal degrees)
LONGITUDE	deg	Longitude (decimal degrees)
VELOCITY	kts	Ground speed in knots
HEADING	deg	True heading (0-360°, 0=North)

DIST	mi	Distance from your location
BEARING	deg	Bearing from you to aircraft (0-360°)

### Row Color Coding

#### Background Colors:

Color	Meaning	Age Range
White/Light Gray	Fresh data	0-30 seconds
Yellow	Stale (warning)	30-60 seconds
Red	Very stale (alert)	60+ seconds

**Text Colors:**

Column	Color	Meaning
SRC	Blue	RF source (radio)
SRC	Orange	OpenSky source (internet)
SIG	Green	Signal strength bars
AGE	Green	Fresh (0-30 sec)
AGE	Orange	Stale (30-60 sec)
AGE	Red	Very stale (60+ sec)

## Wide Video Overlays

Wide video overlays allow you to see aircraft positions directly on your camera view, with circles marking each aircraft's location and identification labels.

### Enabling Overlays

- 1. Click 'Show on Wide' button in GPS/ADS-B panel
- 2. Adjust 'Max Displayed' slider (5-50 aircraft)
- 3. Overlays appear on wide video window

### Overlay Elements

#### Aircraft Circles:

Blue circle = RF source (real-time local detection)

Orange circle = OpenSky source (internet data, 10-sec lag)

#### Aircraft Labels:

Callsign (or ICAO if no callsign)

Altitude in feet

Distance in miles

### Field of View Calculation

Only aircraft within camera FOV are displayed. Position is calculated using:

- Bearing from you to aircraft
- Elevation angle based on altitude and distance
- Current camera pan/tilt position
- Camera FOV (typically 60° horizontal, 40° vertical)

## Troubleshooting Reception Issues

### No Aircraft Displayed

#### Check RTL-SDR Connection:

- Verify USB cable connected
- Try different USB port (avoid USB 3.0 hubs)
- Check for green LED on RTL-SDR (if equipped)

#### Verify dump1090 Installation:

- Open command prompt and type: dump1090
- Should see help text or version information
- If not found: Install dump1090 and add to system PATH

#### Optimize Antenna Placement:

- Raise antenna to highest point possible
- Ensure clear line of sight to sky
- Outdoor placement ideal, window second best
- Vertical polarization (antenna pointing up)

### Low Message Rate

#### Antenna Improvements:

Antenna Type	Expected Performance
Commercial 1090 MHz collinear	200-500+ messages/min
DIY collinear antenna	100-300 messages/min
Ground plane antenna	50-150 messages/min
Stock RTL-SDR antenna	20-50 messages/min

**Gain Optimization:**

- Click 'Configure Gain' button
- Try AUTO GAIN first (-10)
- If Auto fails, try MANUAL: 40-49 dB (typical sweet spot)
- Monitor messages/min and qualified aircraft counOpenSky Issues

**Connection Error:**

- Check internet connection
- Wait for auto-retry (every 10 seconds)
- Check firewall settings (allow UFODAS HTTPS)

**Authentication Failed:**

- Use legacy credentials (not OAuth2)
- Try anonymous access (leave credentials blank)
- Create account at <https://opensky-network.org>

## Signal Strength Interpretation

### Understanding Signal Bars

Bars	Msgs/Min	Quality	Typical Scenario
	60+	Excellent	Overhead or very close
	30-59	Very Good	Within 10-20 miles
	15-29	Good	20-30 miles
	5-14	Fair	30-40 miles, edge of range
	1-4	Weak	40-50 miles, intermittent

### Factors Affecting Signal Strength

**Distance:** Closer = stronger signal, more messages

**Altitude:** Higher altitude = better line of sight, visible much further

**Antenna Quality:** Better antenna = more messages from distant aircraft

**Obstacles:** Buildings, trees, terrain block signals and cause fading

## Performance Optimization

### Recommended Gain Settings

Environment	Recommended Gain
Urban (lots of buildings)	40-45 dB (reduce noise)
Suburban (some buildings)	45-49 dB (balanced)
Rural (open area)	49-52 dB (maximize sensitivity)
Coastal (may be busy)	40-45 dB (reduce noise)

### Display Performance

#### Max Displayed Setting:

- Wide overlays: 5-10 aircraft (reduce clutter)
- Tracker only: 20-50 aircraft (see more data)

#### Automatic Filters:

- Aircraft >150 miles automatically excluded
- Stale aircraft (180+ seconds) removed
- Negative altitudes filtered (invalid data)

## Quick Reference

### Performance Targets

Metric	Poor	Good	Excellent
Messages/min	<20	50-100	100+
Qualified Aircraft	0-2	5-10	10+
Signal Bars (avg)	1	2-3	3-5
OpenSky Aircraft	0	10-30	30+

### Normal Behavior

- Many msgs=1 aircraft are normal (distant, correctly filtered)
- OpenSky 10-second lag is normal (not real-time)
- No signal bars for OpenSky aircraft (internet data, not RF)
- Fewer aircraft at night (less air traffic)
- More aircraft near airports (denser coverage)

### Glossary

**ADS-B:** Automatic Dependent Surveillance-Broadcast

**ICAO:** International Civil Aviation Organization (aircraft identifier)

**MSL:** Mean Sea Level

**RTL-SDR:** Realtek Software Defined Radio (USB receiver)

**dump1090:** ADS-B decoder software

**OpenSky:** OpenSky Network (crowdsourced aircraft data)

**FOV:** Field of View

**Callsign:** Flight identifier (e.g., UAL1234)

**Quality Score:** Internal metric for data completeness

**Signal Strength:** Messages per minute (RF only)

## ADS-B Quick Reference Summary

### Signal Strength Bars (RF Aircraft Only)

Bars	Msgs/Min	Quality	Distance
	60+	Excellent	0-10 mi
	30-59	Very Good	10-20 mi
	15-29	Good	20-30 mi
	5-14	Fair	30-40 mi
	1-4	Weak	40-50 mi

### Tracker Table Columns

Column	Meaning	Color Code
SRC	RF or OS	Blue=RF, Orange=OS
IDENT	Callsign/ICAO	-
SYM	Aircraft symbol	-
SIG	Signal bars	Green (RF only)

TYPE	Aircraft type	-
AGE	Seconds old	Green→Orange→Red
ALTITUDE	Feet MSL	-
VELOCITY	Knots	-
HEADING	Degrees	-
DIST	Miles from you	-
BEARING	Degrees from you	-

## Row Color Meanings

Color	Status	Age
White/Gray	Fresh	0-30 sec
Yellow	Stale	30-60 sec
Red	Very Stale	60+ sec

## Troubleshooting Checklist

### No Aircraft Displayed:

- RTL-SDR connected? (check USB)
- dump1090 installed? (check PATH)
- Antenna positioned? (high, clear view)
- Gain configured? (try Auto or 40-49 dB)
- Air traffic present? (check FlightAware)

### Low Message Rate (<50/min):

- Raise antenna higher
- Move away from interference (USB3, WiFi)
- Optimize gain (Configure Gain button)
- Use better antenna (upgrade from stock)

### OpenSky Not Working:

- Internet connected?
- Wait for auto-retry (10 sec)

- Check credentials (use legacy format)
- RF still works without OpenSky ✓

### Performance Targets

Metric	Good	Excellent
Messages/min	50-100	100+
Qualified Aircraft	5-10	10+
RF + OpenSky Mix	Yes	Yes

### Normal Behavior (Don't Worry!)

- ✓ Many msgs=1 aircraft (distant, filtered out)
- ✓ OpenSky 10-sec lag (normal update rate)
- ✓ No signal bars for OS (internet data, not RF)
- ✓ Fewer aircraft at night (less air traffic)
- ✓ More aircraft near airports (denser coverage)

### Gain Settings (Manual Mode)

Environment	Recommended Gain
Urban	40-45 dB
Suburban	45-49 dB

Rural	49-52 dB
-------	----------

***Or just use Auto Gain (-10)!***

## Appendix B: Mission Control S/W Change Log

V3.13 2-5-2026

1. **NEW** – GPS / ADS-B receivers and display. New display option for the Aux Video Display. Automatically finds a USB GPS device if connected to determine system location. If no GPS device can be found, uses the system IP address information to determine approximate location. Automatically finds any RTL-SDR receiver and implements a ADS-B receiver with displays of aircraft identification, altitude, lat/lon, velocity and more. Creates a log file, C:\OTDAU\adbslog.txt, with all device status and aircraft data. The log file is created when the ADS-B display is selected and closed when deselected or at system quit. Using the system location, calculates and displays the LOS distance to the aircraft.
2. **NEW** – All map images now include the UFODAP logo in the upper right corner.
3. **NEW** – The Video and Data Display includes a Fullscreen button. Click the button to duplicate the display on the main PC monitor. Click it again, or ESC or F11 to exit Fullscreen mode. Fullscreen works for any type of display shown on the Status screen.
4. **NEW** – MSDAU display of temperature displayed as both C and F; Display of pressure in both in Hg and mb. GPS Altitude is displayed in both meters and feet.
5. New version of MSDAU firmware: V3.17 with improved SDR performance when using RTL-SDR hardware. [V3.16 is skipped since it was provided with some new MSDAUs since the last release and we want to be sure to update all MSDAUs to the latest version.]
6. Corrected system response to MSDAU boot loader fault conditions.
7. Corrected fault response to non-existent DAU configurations.
8. Faster data updates including the RF Spectrum.
9. Improvements to MSDAU boot process and messaging.
10. Revised update resolution time of the Aircraft data shown on the map as well as the Aircraft data table to 5 seconds which is the Opensky data update resolution.
11. Added additional ADS-B message decoding and display to provide the Aircraft Category. The category may be one of 25 values including “No information at all”, “Small (15500 to 75000 lbs.)”, “Glider / sailplane”, etc. See the User Guide for more information.
12. Opening Sensors > OTDAU or >MSDAU will open the last sensor of the same type selected without having to use Open.
13. Improvements to MSDAU RF spectrum processing for speed and ability to provide a spectrum across all requested frequencies. NOTE: Full spectrum refresh is composed of concatenated sections of bandwidth with successive

center frequencies. Each section can only cover the maximum bandwidth per sweep of the hardware, i.e., ~20MHz. Thus, the narrower the requested frequency range, the faster the plot will be updated.

14. Corrected DAU location for weather and aircraft data – MC was always using the manually entered value instead of the GPS location when a GPS location is available.
15. Corrected calibration of pressure data – raw data from the SenseHat is offset by using GPS altitude, if available (or 220m if not) and sea level pressure of 1017 hPa.
16. Corrected display of GPS altitude to value in meters rather than feet.
17. OpenSky aircraft data can only be sampled 400 times/day. To prevent unnecessary exhausting this limit, aircraft data is only sampled either once per selection of the Aircraft display or every 10 seconds during Run and a trigger condition. The first line of the display indicates when sampling occurs. You will see changes to the aircraft indicators on the map when sampling picks up new values.
18. Improved detection and response to disconnected DAUs and recovery after reconnection.
19. For an MSDAU, uses GPS data if GPS has a fix, otherwise uses associated location data and switches between them dynamically.
20. Text based data such as MSDAU Data, Weather and Aircraft are now correctly displayed when Fullscreen mode is selected.
21. In the text Status display, you can scroll up to 1000 lines for reference and prior use of Weather, Aircraft or MSDAU Data will not prevent viewing prior lines.

**Changes from V3.13 to V3.14:**

1. Corrected a possible discrepancy between the time displayed with the OSD text in maps vs the time derived from GPS when there is a valid fix from GPS in a connected MSDAU. Added a GPS Time / CPU Time indication to the map text.
2. Same enhanced validation changes as used for OTDAU.

## Appendix C: OTDAU Software Change Log

V2.26 2-5-2026

See the newly revised version of the UFODAP User Guide for more details about the new features.

1. **NEW** – Major upgrade from Python 3.9 to 3.12 resulting in some possible performance improvements in speed and memory optimization.
2. **NEW** – Option to upload user-selected data for analysis to UFODATA. Click Upload in Sharing tab to display Upload form. An email is sent to the first two addresses in the Sharing > Email list after data has been sent to the UFODATA Dropbox. A copy of this email is also sent to the contributor of the data (the user).
3. **NEW** – Optimizations to OTDAU code reduced CPU utilization due to video processing resulting in lower video frame latency. Improvements were also made to video frame latency. A future revision may attempt to use an existing Graphics Processing Unit (GPU) to perform IP camera video stream decoding. A GPU will not be used for USB cameras. Note that GPU/hardware frame decoding is used to greatly reduce CPU loading in, for example, web browsers because decoding as well as video display processing happen only in the GPU. In OTDAU, decoded frames would have to be downloaded from the GPU after each frame decode for processing, which defeats the time saved by GPU vs CPU decoding. Suggestion: To determine the fastest FPS, you can use for a particular camera and minimize frame glitches, (1) in its web page, Video, set the Bit Rate Type to VBR (2) Load that camera and Run. (3) When the Widecam FPS shown stabilizes, set the camera rate to something less than that value. Frame glitches are generally due to frame decoding time greater than frame rate. This is an ongoing development effort – future versions may further improve CPU overhead.
4. **NEW** – Optimized USB camera support allows full frame rate streaming at any resolution. Also provides System configurations with different cameras for wide and tele in any IP/USB combination. Automatically detects all USB cameras and uses the first for USB0 and the second for USB1. Alternately, if the exact name of the camera, as displayed by previously opening it, is entered as the Video URL, then that camera will be used. Onscreen displays with Frame number also now include an estimated value for FPS.

5. **NEW** – The Camera Configuration Assistant is now the IP CCA and there is a new USB CCA, both started from the Camera Configuration window. The USB CCA provides information and verification of USB-interfaced cameras as well as video capture devices you may want to use for input from composite video cameras or HDMI sources. This function lets you know which device to use in a configuration (USB0, USB1,...) regardless of how Windows assigns USB devices.
6. **NEW** – USB Gamepad control of all Manual PTZ functions, in parallel with mouse clicks. The Gamepad is enabled if it is plugged in to any USB port before a System configuration is loaded. See the associated User Guide section for button/function mapping. Tested only with a Logitech Dual Action control P/N 863247-0010.
7. **NEW** – All Wide and Tele images now include the UFODAP logo in the lower right corner. The size of the logo is scaled to the resolution of the camera.
8. **NEW** – If you would like to use an IP camera, PTZ or otherwise, that does not respond properly to ONVIF queries, then you can still use it as if it were a fixed-lens camera. To do this, use “nonptz” for the PTZ Driver entry in your Camera Configuration, instead of “onvifptz”. Alternatively, disable the “PTZ capable” checkbox in its Camera Configuration.
9. **NEW – A new option in Recording** -- “Save a jpg of the digitally zoomed image of each detected but not tracked event” will record one jpg image for each event that does not meet the Tracking “Min time” duration value. If Sound is enabled, each recording is accompanied by a new, higher-pitched tone.
10. **NEW** – The Path display may now show the path of the target object as a series of small thumbnails of the Telephoto view. A thumbnail view of the tracked object is also shown in the upper right of the display. Select this option in Setup > Display, “For Path display, show path as sequence of thumbnails instead of a line”. Try it out on some of the test videos.
11. **NEW – PTDAU** A new type of DAU is now available: A high-performance pan/tilt positioner that can carry up to 10Kg. The production prototype includes PoE++-only power and signal and onboard Rpi computer for IP to P/T control via the Pelco-D interface standard. System configurations for this DAU should use the “ptdau” designation as the Pan/Tilt Unit. A PTU is defined by its Pan/Tilt Unit Configuration where the Pan/Tilt Driver should be entered as “ptudau”. The PTDAU also includes a mount on top for a DSLR camera and USB power and signal interfaces. Any PTU defined as a Pan/Tilt Unit Configuration may be used

as the Pan/Tilt Unit entry in a System configuration. A possible sensor configuration might include two different IP cameras plus a DSLR. Most any type of payload may be possible due to the onboard computing resource.

12. **NEW – PTUSB** The Pan/Tilt positioner, in its USB configuration, may also be used with any compatible device that conforms to the Pelco-D control standard as defined by the document in Downloads and has an RS-485 serial interface. Using an RS-485 to USB converter, OTDAU can control the PTU by defining a Pan/Tilt Configuration using “ptusb” as the Pan/Tilt Driver. The PTDAU, as an option, will also be available with a built-in power supply powered by 120VAC, 50/60HZ in lieu of the PoE interface and Rpi computer.
13. **NEW -- Canon camera control** OTDAU can now control the shutter of any Canon camera that conforms to the latest CCAPI standard. New Recording option to release the shutter at any interval during tracking. Another option enables one snapshot following the initial move to a tracked target. Communication with the camera is via the camera’s built-in WiFi capability. Also, configuration of various camera functions may be viewed on a new DSLR Configuration option in the Camera Configuration. Click on Open to view the camera’s information and view its streaming image (with resolution reduced from the camera’s maximum). Click Snapshot to take one photo. All photos are saved to the camera’s local storage and not uploaded.
14. **NOTE:** Per your camera’s web page, in Setting -- If your camera ONVIF Authentication is ON, then the ONVIF Username and Password, defined in Account > ONVIF must match those used in the Camera configuration. Otherwise, if that camera is referenced in the initial Validation or during Load, then it will not validate or load correctly.
15. **NEW --** System and Camera parameters are now re-read whenever Run is started allowing their updated values to be used without closing and reopening the configuration.
16. **NEW –** Older cameras such as the Dahua 50230, 50232 and 50A320 respond to ONVIF queries for position much slower than more current models (in about 450msec vs 30-60 msec). This creates problems when attempting to maintain control in a PID loop which uses the difference between current position and target location. This version of OTDAU attempts to improve on this by automatically incrementing pan, tilt and zoom values based on commanded velocity of those axes while setting the position values to actual any time they become available. That is, position increments are filled in during periods when

they are not available from the camera itself. This augmented statusing is only applied to the cameras noted above.

17. **NEW** – The Auxiliary Video Telephoto display shows a digital zoom of the telephoto camera image at a fixed 5x zoom. Now it can be adjusted from x1 to x10 using a sliding control in the Setup > Display window. The zoom amount may be changed at any time, whether in Run or not. Try it by loading a test file and opening the Display Options. Then while viewing the Telephoto display, adjust the zoom level and Save. The digital zoom level in the display will change and the level shown at the bottom of the screen.
18. **NEW** – Both the Wide and Aux displays now include a “Fullscreen” button on the top right in green. When this button is clicked, the associated video will appear on the full main PC display. The original OTDAU GUI will also be retained on whichever display it was on when the Fullscreen button was clicked. The display will return to normal if the button, now shown as “Exit Fullscreen” in red or if ESC or F11 is pressed on the keyboard. **TIP:** Before clicking Fullscreen, you can move the GUI window to another monitor. Then, when you click Fullscreen, the selected screen will fill the main monitor while you still have the original GUI available on the secondary monitor.
19. Improved windows control – You can more conveniently keep multiple dialog windows on screen along with the main GUI. Any dialog window will open centered on the main GUI window and not on other possible monitors. Clicking on any window will bring it in front of any other window so you can more easily switch between them and move them around on your desktop or to other monitors.
20. Improved quit/shutdown process that properly closes all open functions. May also improve interface with MC due to proper release of ports.
21. Improved PID control by means of a new velocity-predictive control method.
22. Improved run time process performance measurement to more accurately show OTDAU (Process) CPU use %, overall System use %, RAM used and number of active threads. Changed performance update period to 5 seconds.
23. The Cameras window has been reconfigured to better fit on smaller monitors and to support the new DSLR options.
24. A current measure of camera stream Frames Per Second (FPS) is now displayed on the right side of the bottom of the Wide-Angle display. It is normal for this to vary a bit around the nominal configured value.

25. Corrected an anomaly in zoom value computation for the Dahua 50A230 camera. A desired zoom of x1.0 would result in a small camera zoom control value which would not result in zoom for other cameras but caused the 50A230 to increase its zoom. This caused a continuous, incremental increase in camera zoom each time the camera returned Home or tracking started.
26. Due to PTZ camera motion lag and time to settle on commanded position, OTDAU measures the velocity of a potential target prior to making its initial move of the target to the CFOV. The Y component of this velocity was inverted causing the initial move to fall short vertically. Now corrected – This allows the Crop increment to be smaller and still capture the target after the initial move.
27. Correction for sequential frames in pre-detection write buffer for smooth playback.
28. Corrected Camera and System Save As processes.
29. Removed duplicate move to Home upon System configuration load.
30. **NOTE:** Setting mainstream encoding to H265 in some Dahua camera firmware builds may cause the camera to respond to ONVIF queries for capabilities to be incomplete, resulting in OTDAU assuming the camera has no PTZ ability. If this seems to be the case, use H264 instead of H265.
31. Corrected telephoto video write process.
32. Improvements to Status display operation and messages.
33. If Path analysis detects a non-linear path, the file name path will be appended with “-NLP” instead of “-AP” for clarity.
34. Revised the Analytics file playback function so that when one clicks Step < (back) and the frame number reaches 0, then frame numbers start to decrease beginning at the number of frames in the file.
35. Revised Analytics tracking to more accurately find and follow the likely target. Also improved Night aircraft identification confidence value reporting.
36. Reorganized PTZ Control and Tracking window to fit the smallest screen size.
37. Corrected Flip image selection in Camera configuration – Provided for four different flip directions: "Flip image -- 0: None 1:Up/Dn 2:L/R 3:U/D and L/R". Bug caused some configurations to have flip of 2 (but displayed as 0) which added up to ~30% to CPU overhead.

38. Improved accuracy of displayed CPU utilization during Run time by averaging values in a background task and scaling Memory use to more closely match values reported by Windows Task Manager.
39. System configuration, Enable Pan/Tilt is forced OFF when the configuration is saved if both referenced cameras do not have PT capabilities.
40. Reorganized entries in the Camera Configuration window.
41. Set the “Manual PTZ Controls” label to white font when Dark Mode is enabled for visibility against selected background.
42. Corrected a bug in Authentication that made it appear that wsdm machine ID was not working for some computers. Implemented an alternative method of obtaining system hardware characteristics used for validation to prevent a fatal error in some systems during validation. Also, **if when starting up OTDAU you get a WMI-related error** you will need to restore your WMI repository by entering (or copy/paste) the following commands at an elevated (Admin) command prompt and then restarting the WMI service using wmicmgmt.msc, started from the Windows search box:

```
mofcomp %windir%\System32\wbem\cimwin32.mof  
mofcomp %windir%\System32\wbem\wmiutils.mof  
regsvr32 %windir%\System32\wbem\wbemcore.dll
```
43. System Performance measurements are displayed during Run only in Verbose display mode.
44. Provided for Path Analysis whenever a test file is stopped, not just at end of file.
45. **NOTE:** Manual PTZ control will be enabled when, in System Configuration, either Pan/Tilt or Zoom is enabled or both.
46. Corrected PTZ PID loop controls – Now Integral and Derivative values may be used with expected results for improved responsiveness.
47. All Camera and Tracking settings that exist at the time Run is pressed will be used. No need to reload a configuration to tune any parameters.
48. Corrected and changed operation of Pan/Tilt offsets – Now on the PTZ Control and Tracking window, offsets to camera pan and tilt values (including emulated values for fixed-lens cameras) are set by clicking the lower left button. They are removed by clicking it again. When removed, the AZ and EL values in the Wide

and Tele displays show actual camera positions. The offset for pan consists of its home value plus the Azimuth offset. The tilt offset is its home value plus the Elevation offset. Setting offsets is now independent of setting the Home position of any PTZ device. Offsets are used, for example, for calibration of camera position for Handoff functions.

## Changes from V2.26 to V2.26A

1. **NEW** (inV2.26) – GPS / ADS-B receivers and display. New display option for the Aux Video Display. Automatically finds a USB GPS device if connected to determine system location. If no GPS device can be found, uses the system IP address information to determine approximate location. Automatically finds any RTL-SDR receiver and implements a ADS-B receiver with displays of aircraft identification, altitude, lat/lon, velocity and more. Creates a log file, C:\OTDAU\adbslog.txt, with all device status and aircraft data. The log file is created when the ADS-B display is selected and closed when deselected or at system quit. Using the system location, calculates and displays the LOS distance to the aircraft.
2. **NEW** – Startup splash screen so initial presentation of all parts of the GUI are complete before presented.
3. **N NEW** – Inclusion of OpenSky ADS-B aircraft data as well as data from an RF SDR for more inclusive coverage than can be available with an SDR alone. Aircraft that are in the wide view when display is enabled will be included in the aircraft data table for reference.
4. The Path display can get very crowded after a large number of paths are collected. Thus, a parameter was added in Setup > Displays to set the maximum count of overlaid paths before the display is reset and more paths are accumulated. All paths in one run have one set of increasing path numbers corresponding to folder numbers regardless of how many sets of paths are collected.
5. Resolved a problem that caused a Dropbox error report if the internet was not available without the use of the data sharing feature.
6. Eliminated the error “Initializing optimized YOLO recognizer CRITICAL ERROR initializing YOLO: [Errno 13] Permission denied: 'C:\Program Files (x86)\OTDAU\\_internal\yolo-coco-v4\yolo-coco-v4”. YOLO recognition is now ~3-5x faster and operates in apparent real-time, like SSD. It is now even more

accurate than SSD. Note that if both are selected, then the identification will be from the one with the higher confidence level.

- 7.
8. Correction for function of USB cameras.
9. Cameras close without timeout messages.
10. Authorization no longer needs periodic re-validation due to a bug in machine ID detection.
11. Close will immediately terminate attempts to open a camera .
12. ONVIF status request errors after camera correctly opened
13. Corrected file folder locations for selecting and saving new cameras, system configurations and positioners so that user-modified or created devices will be retained in C:\OTDAU regardless of new software version releases, as intended.
14. Removed blank lines in the tracking log file.
15. Corrected file logic so that all folders will be labeled (not skipped) if the option to modify folder names is selected in target identification.

## Composite changes from V2.26 to 2.27

1. **NEW** (in V2.26) – GPS / ADS-B receivers and display. New display option for the Aux Video Display. Automatically finds a USB GPS device if connected to determine system location. If no GPS device can be found, uses the system IP address information to determine approximate location. Automatically finds any RTL-SDR receiver and implements a ADS-B receiver with displays of aircraft identification, altitude, lat/lon, velocity and more. Creates a log file, C:\OTDAU\adbslog.txt, with all device status and aircraft data. The log file is created when the ADS-B display is selected and closed when deselected or at system quit. Using the system location, calculates and displays the LOS distance to the aircraft.
2. **NEW** – Startup splash screen so initial presentation of all parts of the GUI are complete before presented.
3. **NEW** – Inclusion of OpenSky ADS-B aircraft data as well as data from an RF SDR for more inclusive coverage than can be available with an SDR alone. Aircraft that are in the wide view when display is enabled will be included in the aircraft data table for reference.

4. **NEW** – FPS optimization by user pipe resolution setting in Camera Configuration:  
**Why It's Needed**

OTDAU receives video from the camera through a Windows data pipe. At 4K (3840×2160) and 20fps, the raw video stream is about 500 MB/s — more than most PCs can move through a pipe reliably. When the pipe can't keep up, frames are dropped or delayed, which directly reduces the detection frame rate and can cause the camera stream to stall and restart.

The Pipe Resolution setting solves this by having the system scale the video down *before* it enters the pipe. The camera still **records at full native resolution** — only the stream used for detection and display is scaled. So, a 4K camera can record in 4K while OTDAU detects objects at 1080p or 720p, which the pipe can deliver reliably at full frame rate.

### **How to Use It**

Enter the camera's native resolution and FPS in the Horiz Res, Vert Res, and FPS fields first.

Click **Auto-detect** — this measures your PC's actual pipe throughput and automatically selects the highest resolution that your system can sustain at the camera's target FPS.

If you prefer to choose manually, click one of the preset buttons. The MB/s figure updates instantly so you can see whether the selection is within your PC's capability (green = safe, orange = marginal, red = too fast).

Click **Reload** to restart the camera at the new pipe resolution. Detection and display will update immediately; recordings remain at full camera resolution.

The native resolution preset is fine for 1080p cameras on modern hardware. The Auto-detect recommendation is most important for 4K cameras or older/slower PCs.

5. The Path display can get very crowded after a large number of paths are collected. Thus, a parameter was added in Setup > Displays to set the maximum count of overlaid paths before the display is reset and more paths are accumulated. All paths in one run have one set of increasing path numbers corresponding to folder numbers regardless of how many sets of paths are collected.
6. Resolved a problem that caused a Dropbox error report if the internet was not available without the use of the data sharing feature.
7. Eliminated the error "Initializing optimized YOLO recognizer CRITICAL ERROR initializing YOLO: [Errno 13] Permission denied: 'C:\Program Files (x86)\OTDAU\\_internal\yolo-coco-v4\yolo-coco-v4". YOLO recognition is now ~3-5x faster and operates in apparent real-time, like SSD. It is now even more accurate than SSD. Note that if both are selected, then the identification will be from the one with the higher confidence level.
8. Correction for function of USB cameras.
9. Cameras close without timeout messages.
10. Authorization no longer needs periodic re-validation due to a bug in machine ID detection.
11. Close will immediately terminate attempts to open a camera .
12. ONVIF status request errors after camera correctly opened
13. Corrected file folder locations for selecting and saving new cameras, system configurations and positioners so that user-modified or created devices will be retained in C:\OTDAU regardless of new software version releases, as intended.
14. Removed blank lines in the tracking log file.

15. Corrected file logic so that all folders will be labeled (not skipped) if the option to modify folder names is selected in target identification.
16. Enter a location and click Look Up / Validate to convert it to latitude/longitude values. These values will be used for the ADS-B location if no GPS hardware is connected or if it is, no fix has been acquired yet. All GPS and ADS-B options are saved in C:\OTDAU\SystemOptions.txt upon Apply and restored when OTDAU is started.
17. When loading a System configuration, Close will terminate the load immediately without having to wait for the full timeout due to an incorrect configuration.
18. Corrected a problem preventing correct file writing and continuation at end of tracking.
19. Corrected a problem such that each video file written will use the codec specified in the individual tele and wide camera configurations, whether they are the same or different.
20. Corrected issues related to use of the pre-detection loop buffer for tele (Aux) frames recording. NOTE: The pre-detection time applies only to the selected Aux recording source, not to the Wide recording. For example, for a pre-detection time of 3 seconds, if the time from start of tracking to end of tracking (restart) is 10 seconds, then the wide recording time would be 10 seconds and the Aux (tele) recording time would be 13 seconds.
21. Path recording corrected so that the final path annotation of path number and inflection point are included in the recorded frames. In thumbnail path mode, outlined the thumbnail(s) at the non-linear inflection point(s) in red.
22. Additional improvements to frame processing efficiency for lower CPU overhead and faster operation, especially at higher resolutions.
23. Eliminated sources of jitter in video recordings.
24. Fixed log file overflow which could cause a crash after a long tracking period.
25. Corrected a typo in the team.ufodap email address that caused the data upload process to fail to complete.
26. Improved centering of GUI on screen regardless of resolution.  
  
Improved USB camera configuration assistant – When the CCA is run from the Camera Configuration window, all attached USB cameras are detected and

tested for all available resolutions and corresponding FPS for each. Then, if any USB camera is loaded, a mismatch between its configuration values for resolution and FPS can be compared to what the associated camera is capable of. If there is a mismatch, then a fault message provides the details of what needs to be modified for a successful load. If a USB camera is loaded prior to running the USB CCA, then the CCA is automatically invoked to determine all attached camera characteristics. When that is completed, just close the CCA and load the required camera again.

## Composite changes from V2.27 to 2.28

1. **NEW** – OTDAU saves all lengthy data files such as the avi test videos and YOLO's recognition data in a cloud-based repository instead of bundling it in with the rest of the code. This reduces the size of the setup file by about half, which reduces download time from SendOwl. The data files are downloaded and installed during setup.
2. **NEW** – Instead of a single Bounding box or circle, you can define up to 10 boxes or circles. Click on the Bounding Box or Bounding Circle button and then draw up to 10 regions. The boxes or circles may overlap. Click on an existing region to delete it. A second click on the Bounding button saves the definition of bounding regions and eliminates any overlapping lines so that bounding regions that are not simple rectangles or circles may be defined. Compatible with prior System configurations with a single region.
3. **NEW** – You can use SSD to identify foliage in analytics and then, as an option, enable restart of tracking if foliage is recognized. This may be a better option than only using a bounding box to eliminate foliage – If a tracked target flies into foliage, the original target may be quickly reacquired, and tracking continue instead of the foliage becoming the tracking focus. This may be especially useful when using a fixed camera with a bounding box so that it is not necessary to enable the option to confine tracking to the box area only. Tracking may continue until the target gets to foliage without trapping tracking there. Without this option, clutter detection may also terminate tracking. (**Note** that YOLO detection of foliage may also work but since the YOLO foliage category was trained on potted plants, it may not be very useful for this purpose.)
4. **NEW** -- YOLOv3 and YOLOv4 Both Supported The YOLO recognizer now supports both v3 and v4 model weights. The version is selectable at runtime; v4 remains the default. GPU Acceleration for YOLO (Where Available) The packaged build now automatically bundles CUDA runtime libraries if they are present on the build machine, enabling GPU-accelerated YOLO inference on systems with an NVIDIA GPU. CPU-only operations are unchanged on machines without CUDA.
5. **NEW** --Tracking crop box around the tracked object changed from a box to just corner brackets for less obstruction of the object and its surroundings. With this change, you may now prefer smaller values of Crop increment in Tracking settings.
6. **Frame Rate (4K Camera) improvements:**
  - Identified that 3840×2160 cameras were piping full 4K frames (24.9 MB each) to the detection pipeline, capping frame rate at ~5 fps. Auto-scaling now

downscales the pipe to 1920×1080 for processing while recording remains at native resolution.

- Added CUDA/GPU hardware-accelerated H.264 decoding via NVIDIA NVDEC — the GTX 1080 now handles video decode, freeing the CPU entirely from that task.
- Disabled Windows Efficiency Mode (EcoQoS) at startup, which was throttling the process priority and starving the video capture threads.
- Idle frame rate had been throttled to 5 fps when not running, reducing CPU load from ~21% to ~10% while the system is standing by.

#### **7. Detection Pipeline improvements:**

- Corrected a coordinate-space mismatch where detection area thresholds (min/max area) were being multiplied by a pipe-scaling factor, making the effective Max area 4× smaller than configured — causing valid targets to be rejected as "too large."
- Fixed the tracker silently dying when the tracker referenced an undefined variable (com vs self.com), which caused zero detections without any error message.
- Forced the background subtraction tracker to use the CPU path — its internal GPU/UMat path mixed incompatible types, producing silent failures with GPU enabled.

#### **8. Recording improvements:**

- Wide-angle video now records at native camera resolution (3840×2160) by upscaling pipe frames before writing, matching the zoom recording resolution. Auto-switches codec from XVID to MJPEG for 4K frames since MJPEG is significantly faster for large frame sizes.
  - AVI test file frame counter changed from `cap.get(CAP_PROP_POS_FRAMES)` (unreliable for some codecs, returning a stale value) to a simple incrementing counter, fixing a bug where the duplicate frame detection filter was blocking every frame after the first.
9. Corrected a pre-detection tele recording interval problem where the target would start at the detection interval time and then jump back to the correct start before completing the correct recording.

10. Automatic compensation in ONVIF driver authentication for passwords with special characters.
11. Camera ONVIF connection authentication process improved to function more reliably – Dahua cameras connect with ONVIF Authentication ON or OFF and without PC time sync; Uniview cameras need ONVIF set to On in Network > Service Config > ONVIF. In general, for any IP camera, it is probably best to set ONVIF ON and synchronize time to your PC.
12. Made testing for internet connection more robust under various conditions. Improved user interface for conditions where connection availability is not immediate. When validating from Manage license, wait for Exit button before returning to OTDAU. To support field operations, does not need to check for internet connectivity if a license file with key already exists. Also, verifies that the key, computer ID and a valid camera (or USB) were validated at some time. If so, then OTDAU is immediately started.
13. Corrected code for recording selection of wide video with digital zoom. This selection had been recording just the wide video stream without text.
14. Revised ONVIF driver to provide more robust feedback for conditions that may cause an inability to connect to a camera.
15. Control buttons only change background color from white when their function is active.
16. Made button background colors more consistent – white until activated and then a color(s) during use.
17. Improved the way paths are recorded – Individual paths are recorded if selected in the same subfolder as wide video files. Boxes surrounding thumbnails are the same color as the folder index for ease of identification in the jpg composite of all paths. The composite is written to the group folder along with the log and json files. The size of each thumbnail and the spacing between them is scaled to the size of the image in the thumbnail. Continuous green line paths are available when selected in Setup > Display.
18. GPU availability status for user's computer is displayed upon startup.
19. Revised path nonlinearity detection with more consisted detection in both x and y direction changes:

**Threshold raised 25°→45°** — a 45° direction change is a genuine course correction (a right-angle turn at 90° would register as nonlinear with headroom to spare).

Tracking jitters typically cause <15° heading wobble, so 45° gives a clean margin.

**Minimum segment length 20px** — a direction change is only counted if the path segment is at least 20 pixels long. Sub-pixel or very short steps are pure tracking noise and are now ignored regardless of their apparent angle change.

20. The Nighttime Aircraft Identifier is now also referred to as NAI. The NAI confidence formula has been improved: now uses rate score (how close to ideal aircraft strobe rate) combined with cycle count score, rather than the old backwards formula that rewarded faster rates.
21. The selected identification method has been added to the thumbnail and text for real-time analysis during tracking. This lets you know which method had the highest confidence for the current track – ‘YOLOv4’, ‘YOLOv5’, ‘SSD’, or ‘NAS’.
22. Corrected functioning of start/stop timing in System configuration when the time overlaps one day to the next.
23. Corrected Uniview camera support including the use of special characters in passwords.
24. Improvements to the initial tracking detection process for more reliable target capture.
25. Added option in Analysis to automatically abort tracking if foliage is identified to minimize time spent hunting without a target.
26. Corrected operation of the Min time tracking parameter so that it can correctly exclude fast-moving objects such as birds.
27. Improved Target Retention After Initial Acquisition -- A crop box positioning error was causing the system to lose the target immediately after the first few tracking events when the target was moving quickly. The detection region now correctly spans both the target's current position and its predicted position, so fast-moving targets are retained through the full tracking sequence.
28. Path Recording Now Correct for AVI Files -- When using path recording mode with AVI input, the saved video file was the plain wide video instead of the path overlay visible on the aux display. The recorded file now matches what is shown on screen — the accumulated target path with numbered event markers.

**Prior release notes are listed in earlier versions of this document.**

# Appendix D: MSDAU Component Data Sheets



## LSM9DS1

iNEMO inertial module:  
3D accelerometer, 3D gyroscope, 3D magnetometer

Datasheet - production data

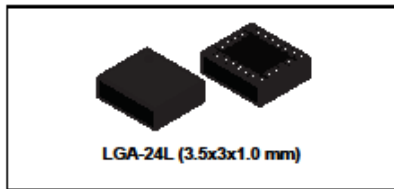

### Applications

- Indoor navigation
- Smart user interfaces
- Advanced gesture recognition
- Gaming and virtual reality input devices
- Display/map orientation and browsing

### Description

The LSM9DS1 is a system-in-package featuring a 3D digital linear acceleration sensor, a 3D digital angular rate sensor, and a 3D digital magnetic sensor.

The LSM9DS1 has a linear acceleration full scale of  $\pm 2g/\pm 4g/\pm 8g/\pm 16g$ , a magnetic field full scale of  $\pm 4g/\pm 8g/\pm 12g/\pm 16g$  gauss and an angular rate of  $\pm 245/\pm 500/\pm 2000$  dps.

The LSM9DS1 includes an I<sup>2</sup>C serial bus interface supporting standard and fast mode (100 kHz and 400 kHz) and an SPI serial standard interface.

Magnetic, accelerometer and gyroscope sensing can be enabled or set in power-down mode separately for smart power management.

The LSM9DS1 is available in a plastic land grid array package (LGA) and it is guaranteed to operate over an extended temperature range from -40 °C to +85 °C.

### Features

- 3 acceleration channels, 3 angular rate channels, 3 magnetic field channels
- $\pm 2/\pm 4/\pm 8/\pm 16g$  linear acceleration full scale
- $\pm 4/\pm 8/\pm 12/\pm 16$  gauss magnetic full scale
- $\pm 245/\pm 500/\pm 2000$  dps angular rate full scale
- 16-bit data output
- SPI / I<sup>2</sup>C serial interfaces
- Analog supply voltage 1.9 V to 3.6 V
- "Always-on" eco power mode down to 1.9 mA
- Programmable interrupt generators
- Embedded temperature sensor
- Embedded FIFO
- Position and motion detection functions
- Click/double-click recognition
- Intelligent power saving for handheld devices
- ECOPACK<sup>®</sup>, RoHS and "Green" compliant

Table 1. Device summary

Part number	Temperature range [°C]	Package	Packing
LSM9DS1	-40 to +85	LGA-24L	Tray
LSM9DS1TR	-40 to +85	LGA-24L	Tape and reel

## Capacitive digital sensor for relative humidity and temperature

Datasheet - preliminary data

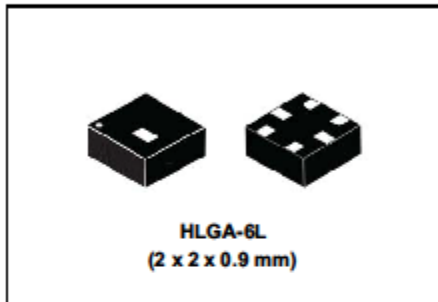

### Features

- 0 to 100% relative humidity range
- Supply voltage: 1.7 to 3.6 V
- Low power consumption: 2  $\mu$ A @ 1 Hz ODR
- Selectable ODR from 1 Hz to 12.5 Hz
- High rH sensitivity: 0.004% rH/LSB
- Humidity accuracy:  $\pm$  4.5% rH, 20 to +80% rH
- Temperature accuracy:  $\pm$  0.5  $^{\circ}$ C, 15 to +40  $^{\circ}$ C
- Embedded 16-bit ADC
- 16-bit humidity and temperature output data
- SPI and I<sup>2</sup>C interfaces
- Factory calibrated
- Tiny 2 x 2 x 0.9 mm package
- ECOPACK<sup>®</sup> compliant

### Applications

- Air conditioning, heating and ventilation
- Air humidifier
- Refrigerators
- Wearable devices
- Smart home automation
- Industrial automation

### Description

The HTS221 is an ultra compact sensor for relative humidity and temperature. It includes a sensing element and a mixed signal ASIC to provide the measurement information through digital serial interfaces.

The sensing element consists of a polymer dielectric planar capacitor structure capable of detecting relative humidity variations and is manufactured using a dedicated ST process.

The HTS221 is available in a small top-holed cap land grid array (HLGA) package guaranteed to operate over a temperature range from -40  $^{\circ}$ C to +120  $^{\circ}$ C.

Table 1. Device summary

Order codes	Temperature range [ $^{\circ}$ C]	Package	Packing
HTS221TR	-40 to +120	HLGA-6L	Tape and reel
HTS221			Tray