

SpatialLight LCoS Display Manufacturing

May 2006

Laminate Fabrication

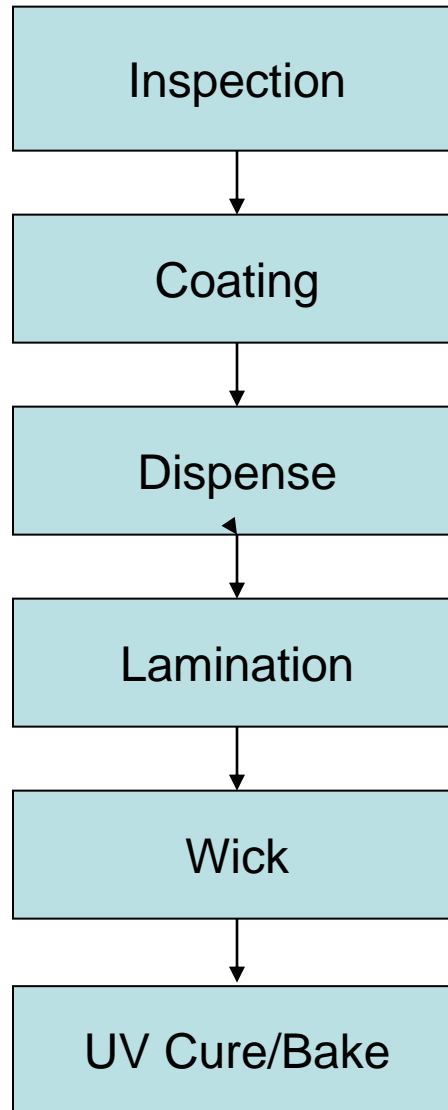

Visual Wafer Inspection

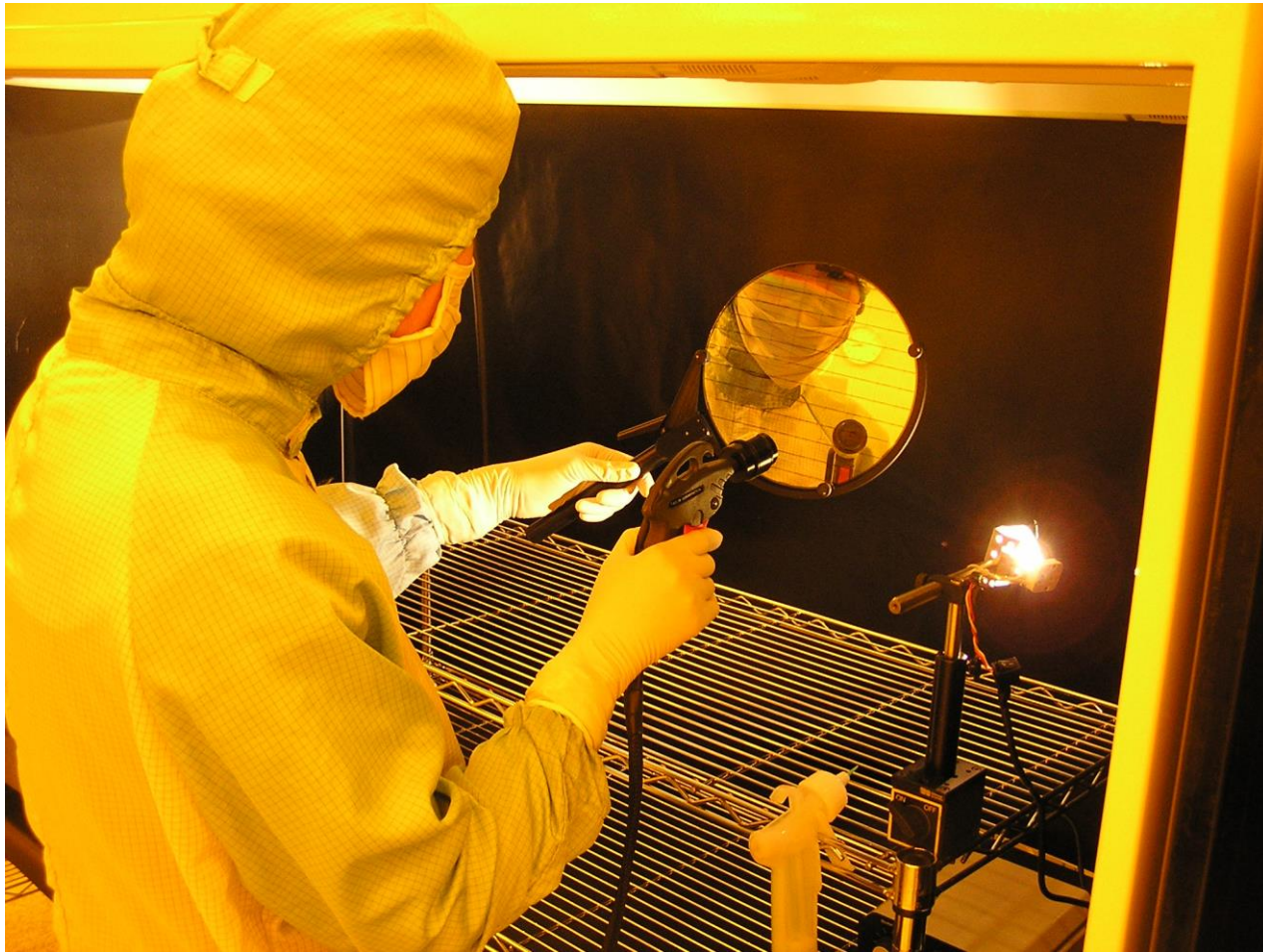

KLA-Tencor Wafer Laser Scanner



Leica Wafer Microscopoe

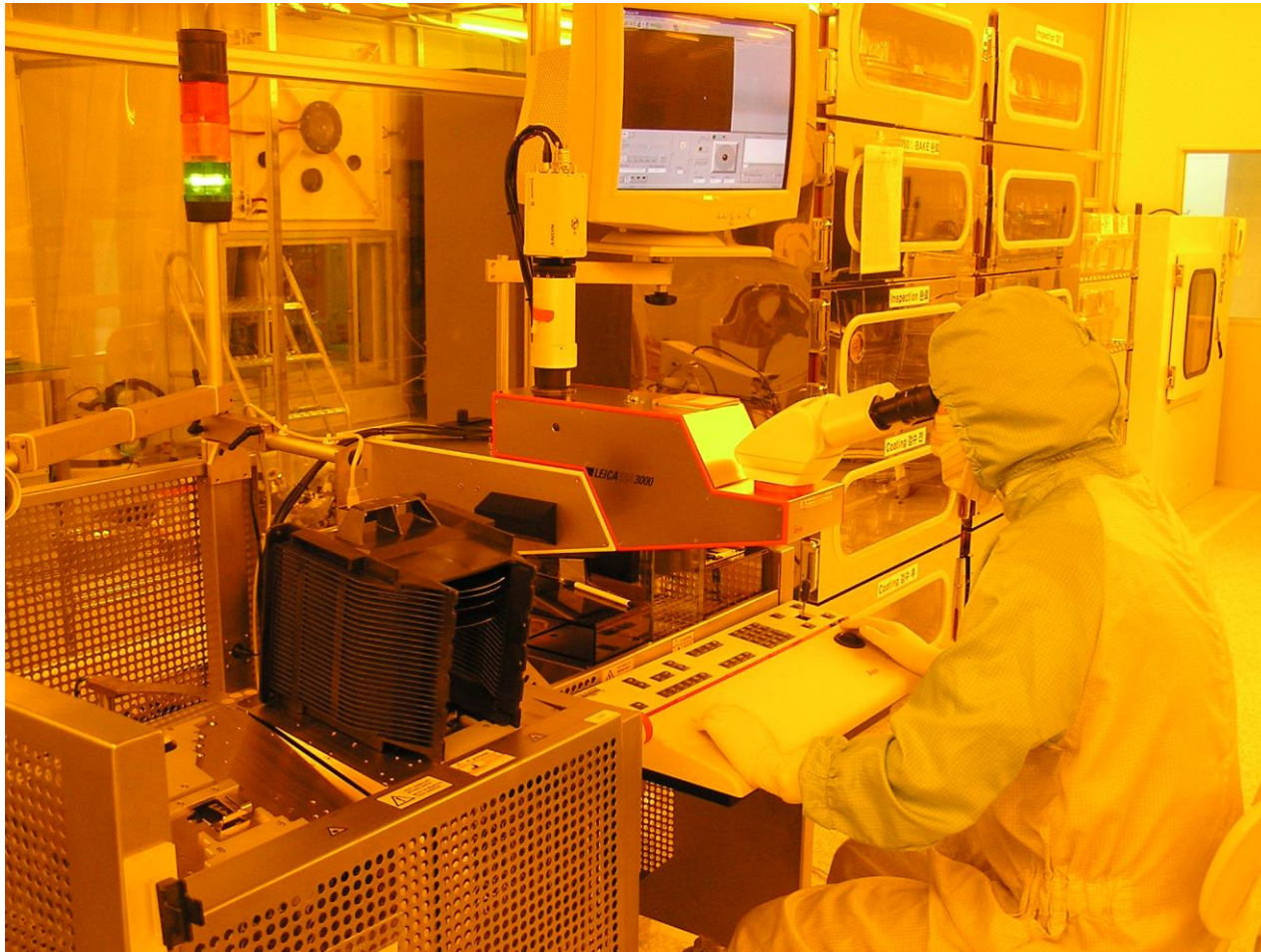

Coating Chamber



Coating Chamber Load/Unload



Pre-Tilt Measurement



Dispense and Lamination



Perimeter Seal Dispense



Lamination Station

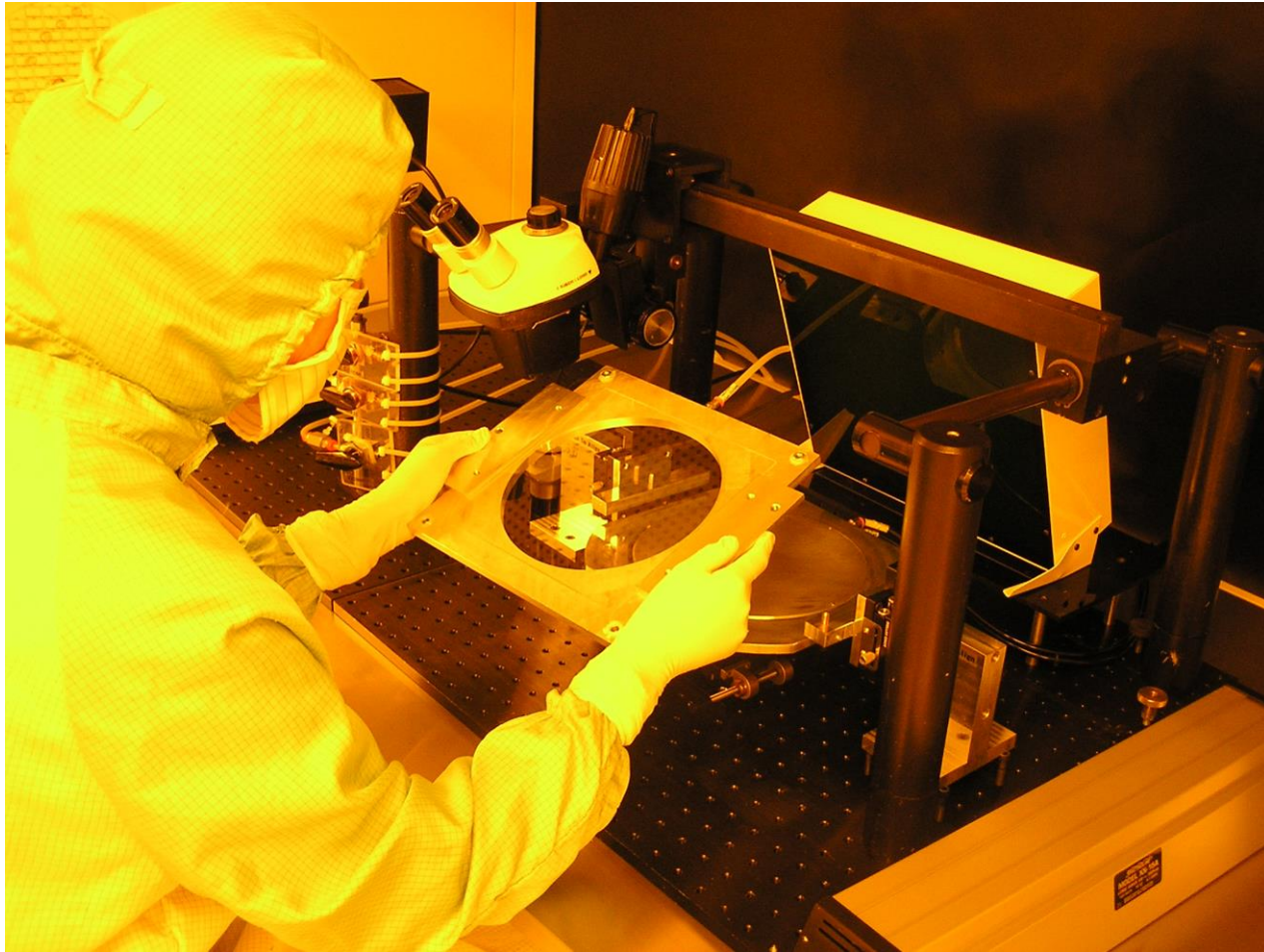

UV Curing Racks

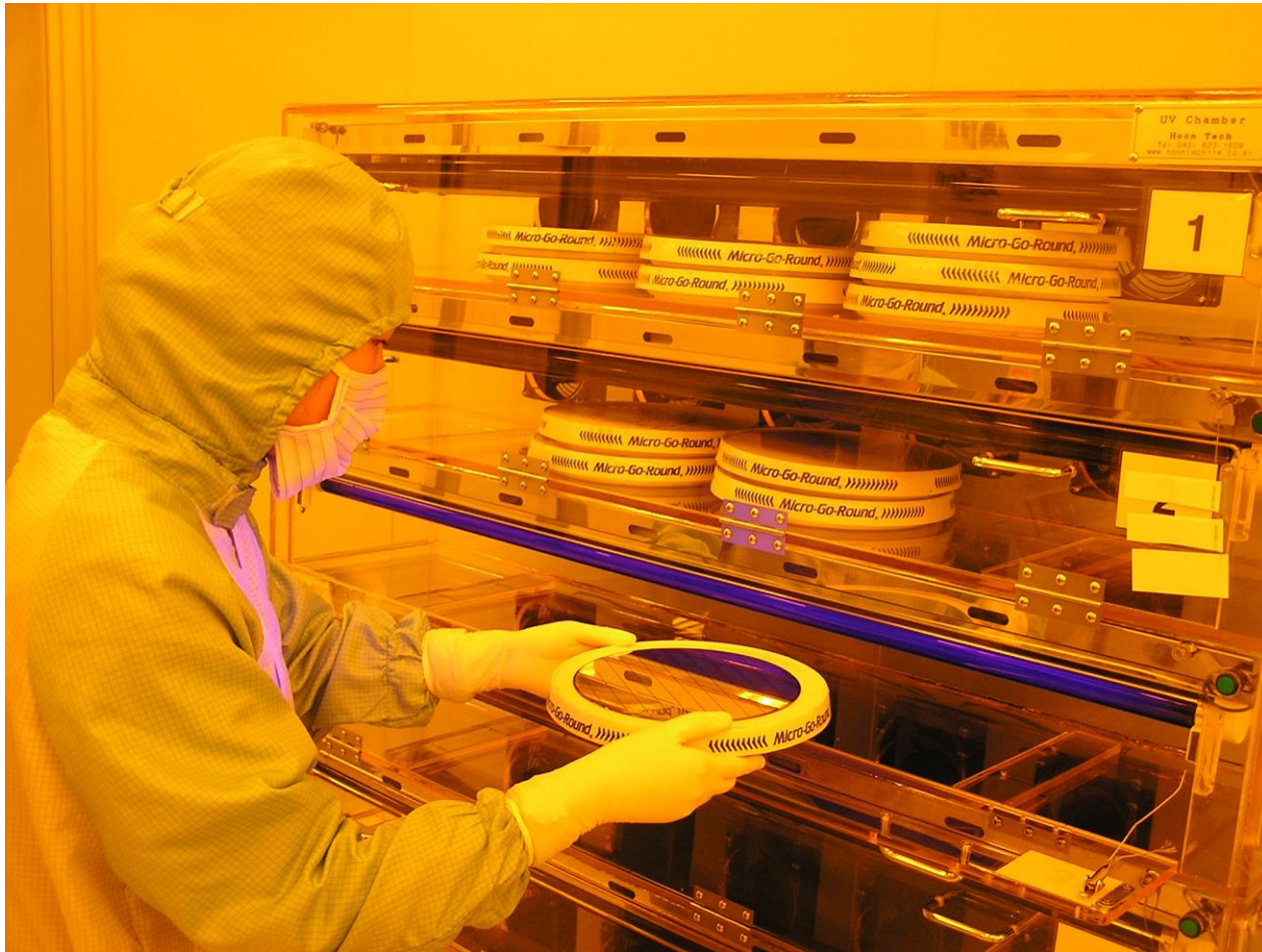

Wafer Defect Analysis

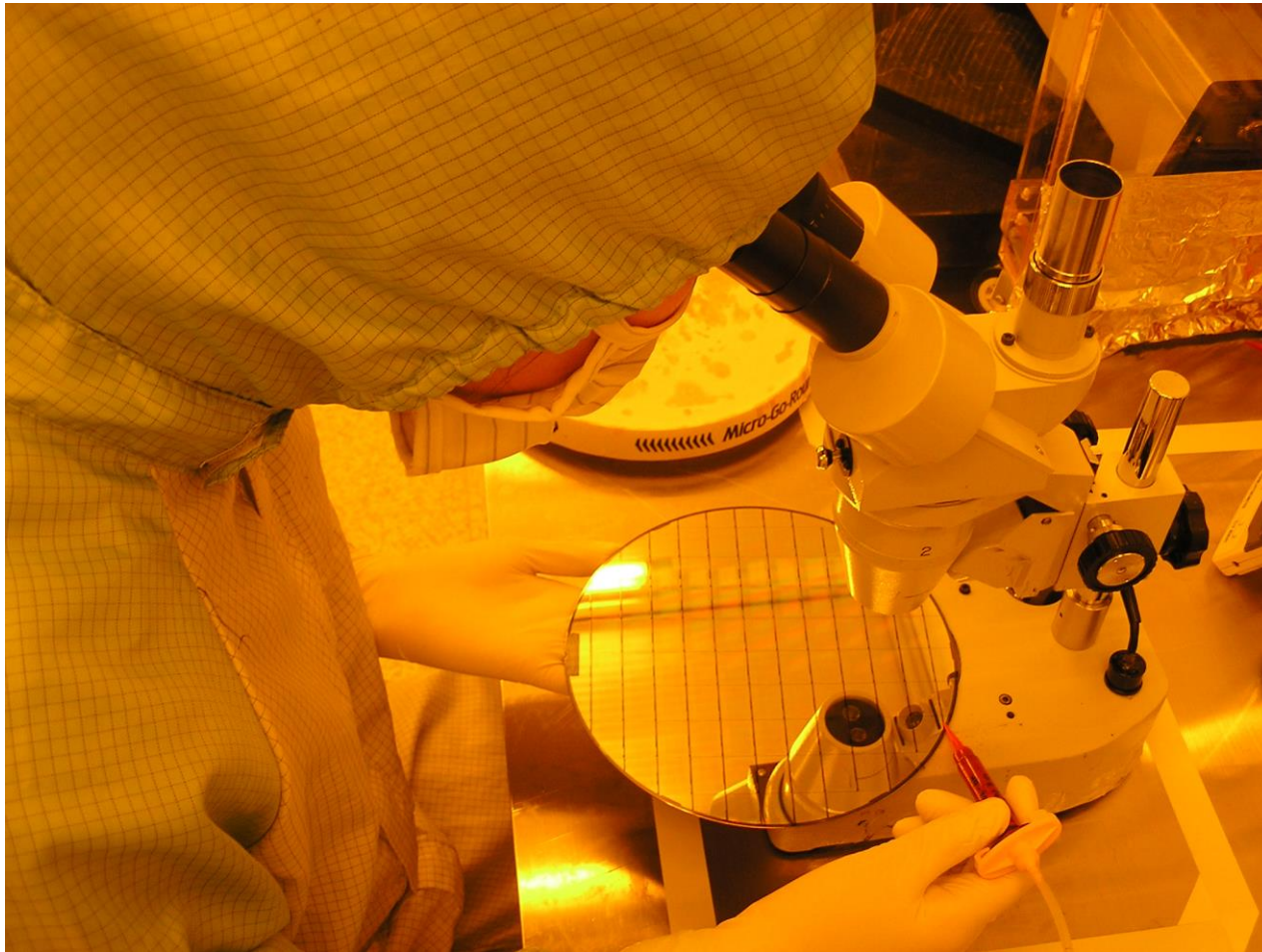

Cell Separation

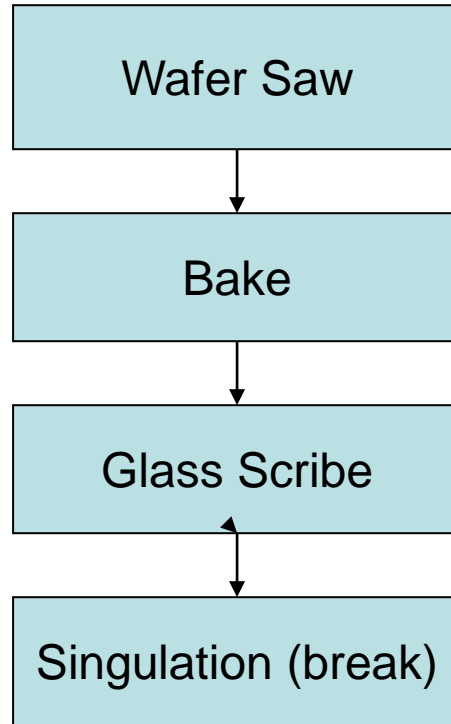

Laminate Thickness Gauging

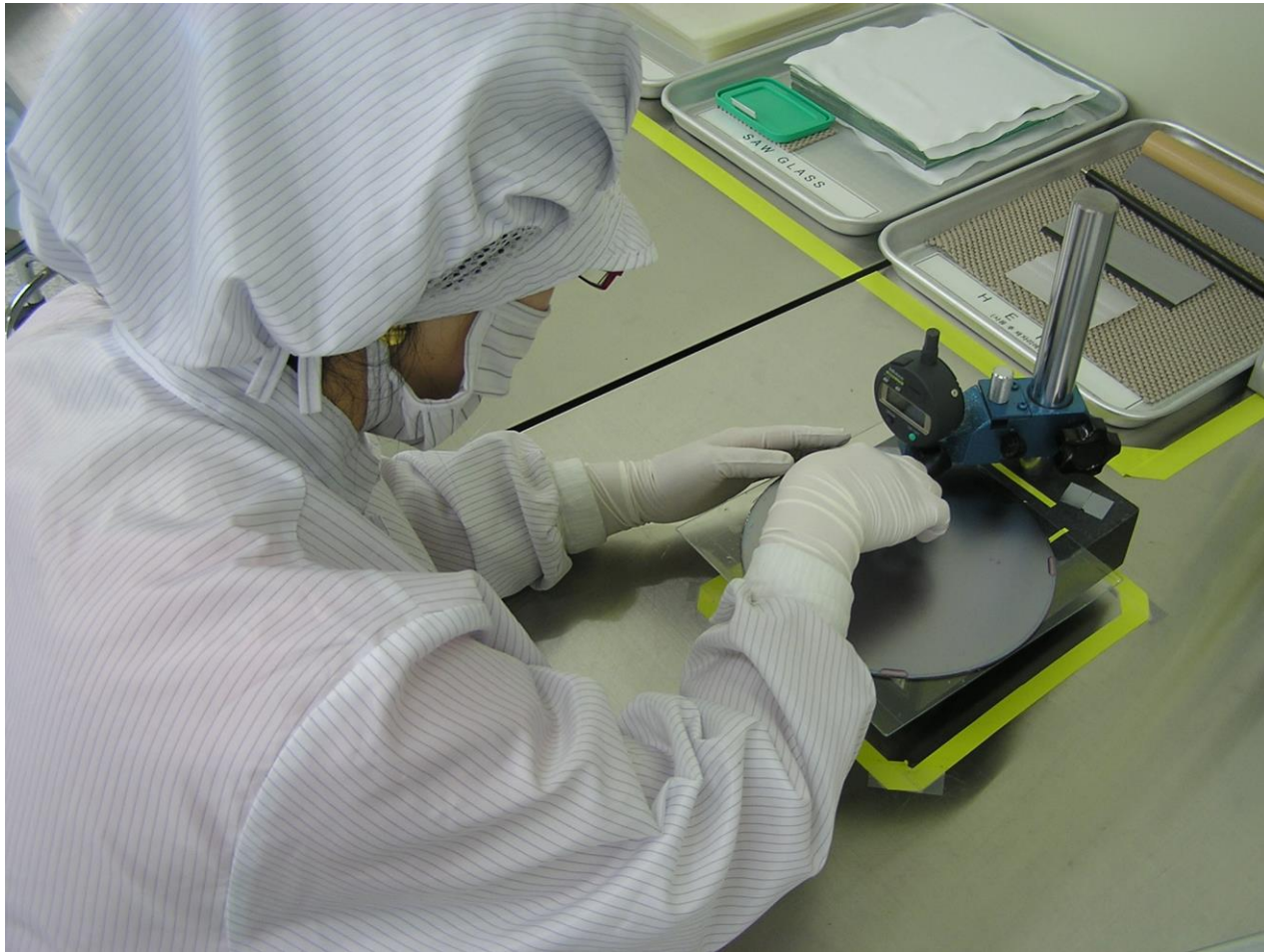

Wafer Saws



Wafer Saw



Post Saw Bake Ovens



Scribe and Break



Glass Scribe



Singulation Break

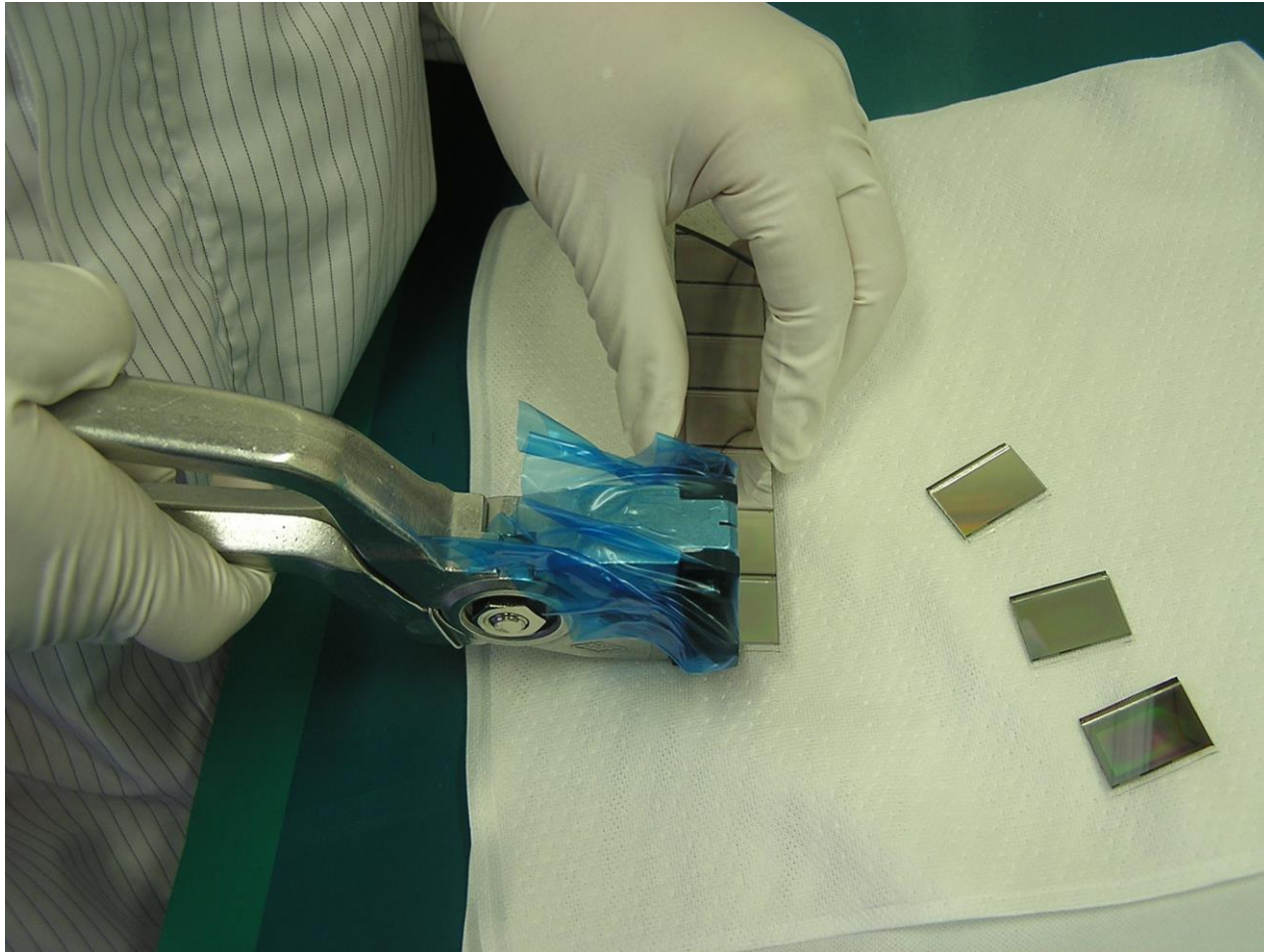

Partially Singulated Wafer

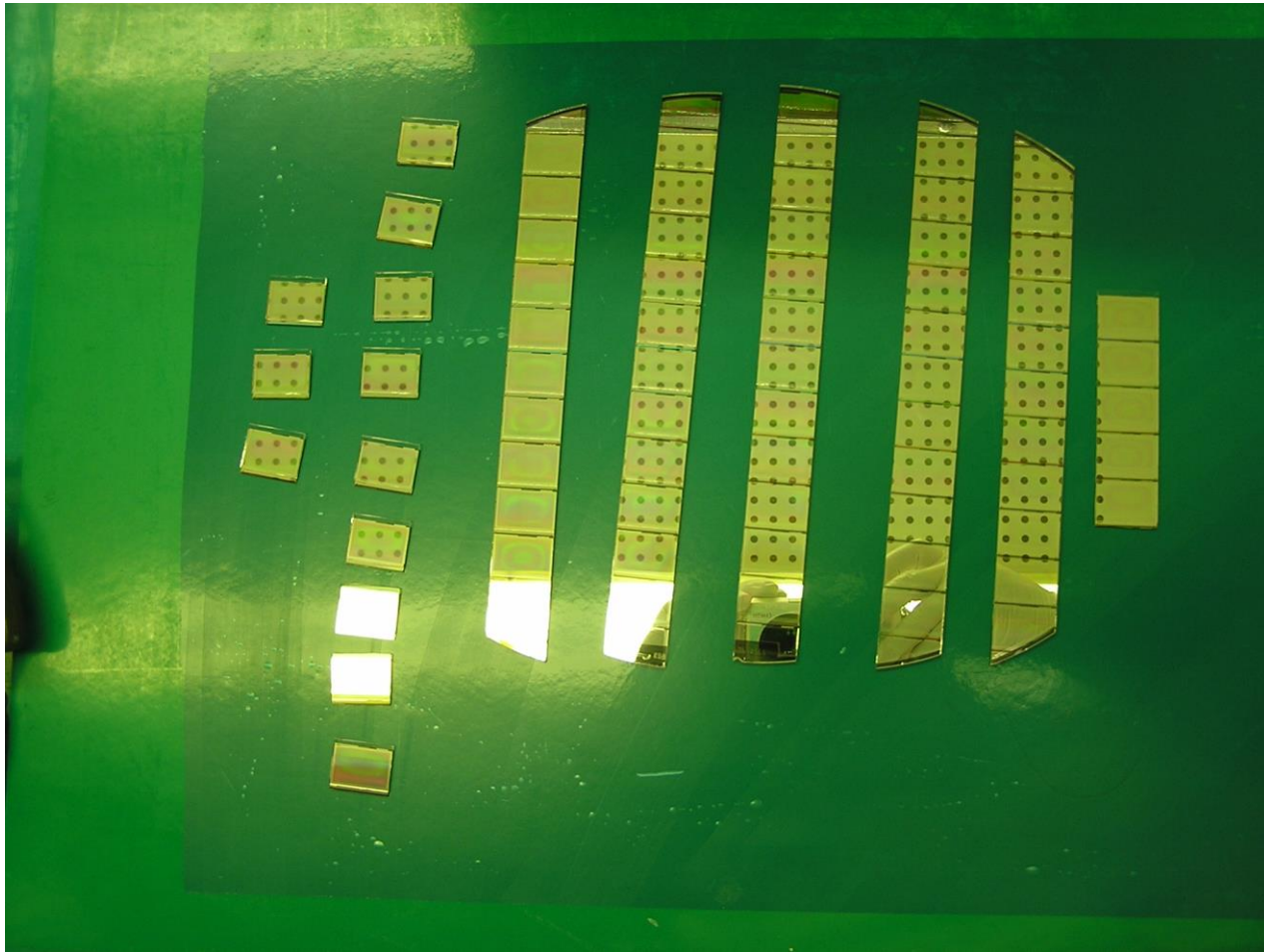

LC Fill and Plug

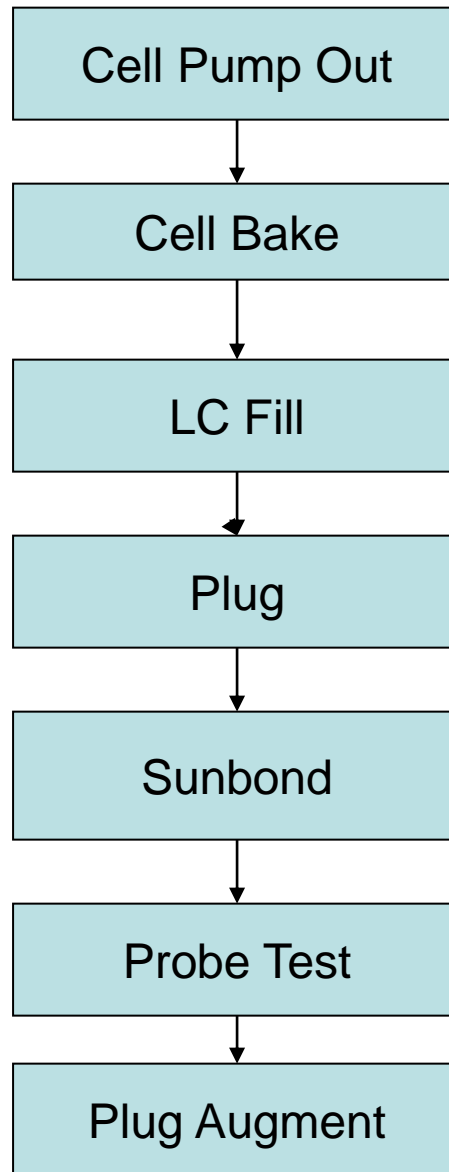

LC Fill



LC Fill Chamber

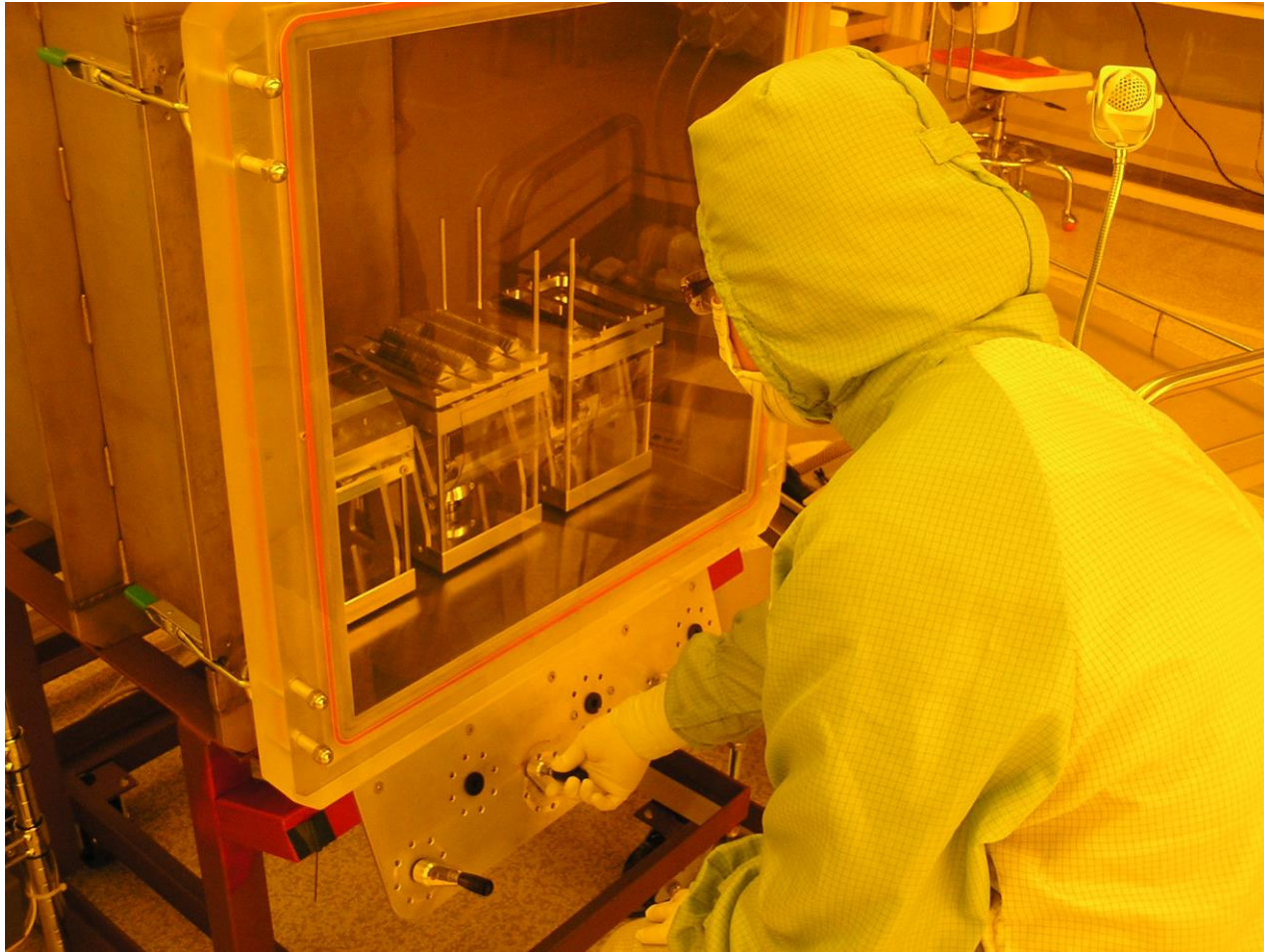

LC Fill Chamber Closeup

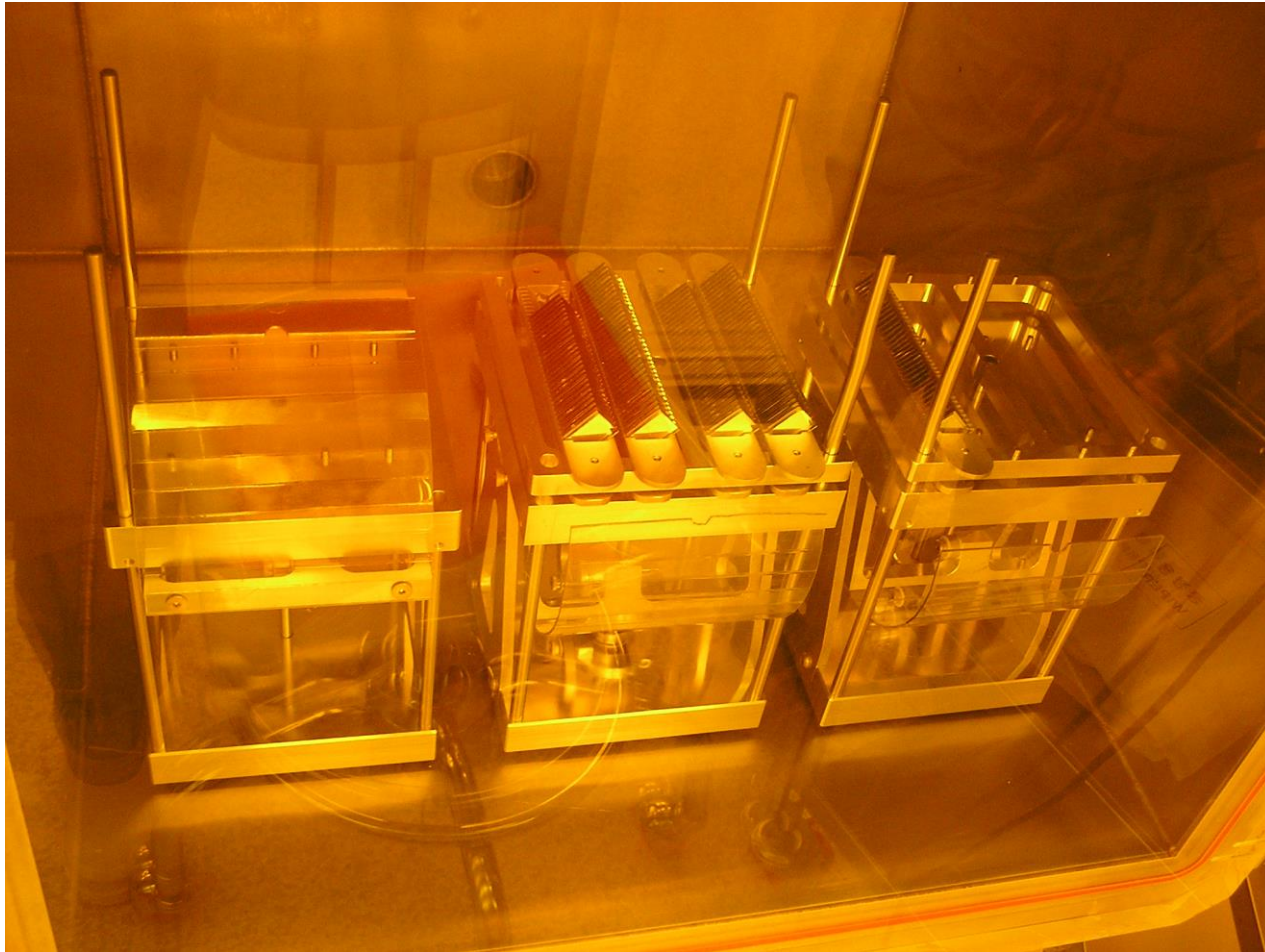

Cell Plugging



Plug Dispense

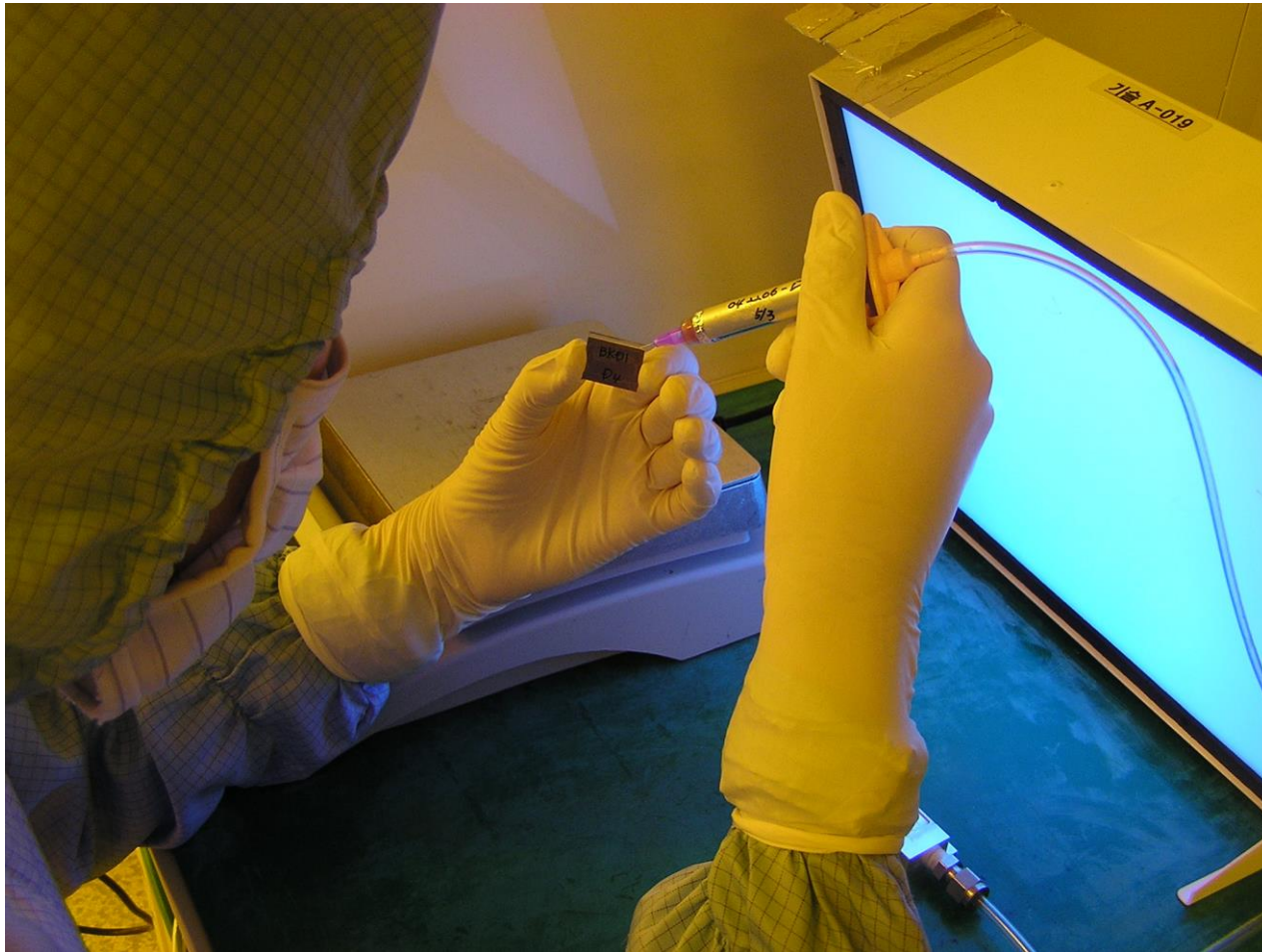

Plug Pulldown Check



Plug Spot UV Cure



Plug UV Cure



Plug Thermal Cure



Fringe Inspection

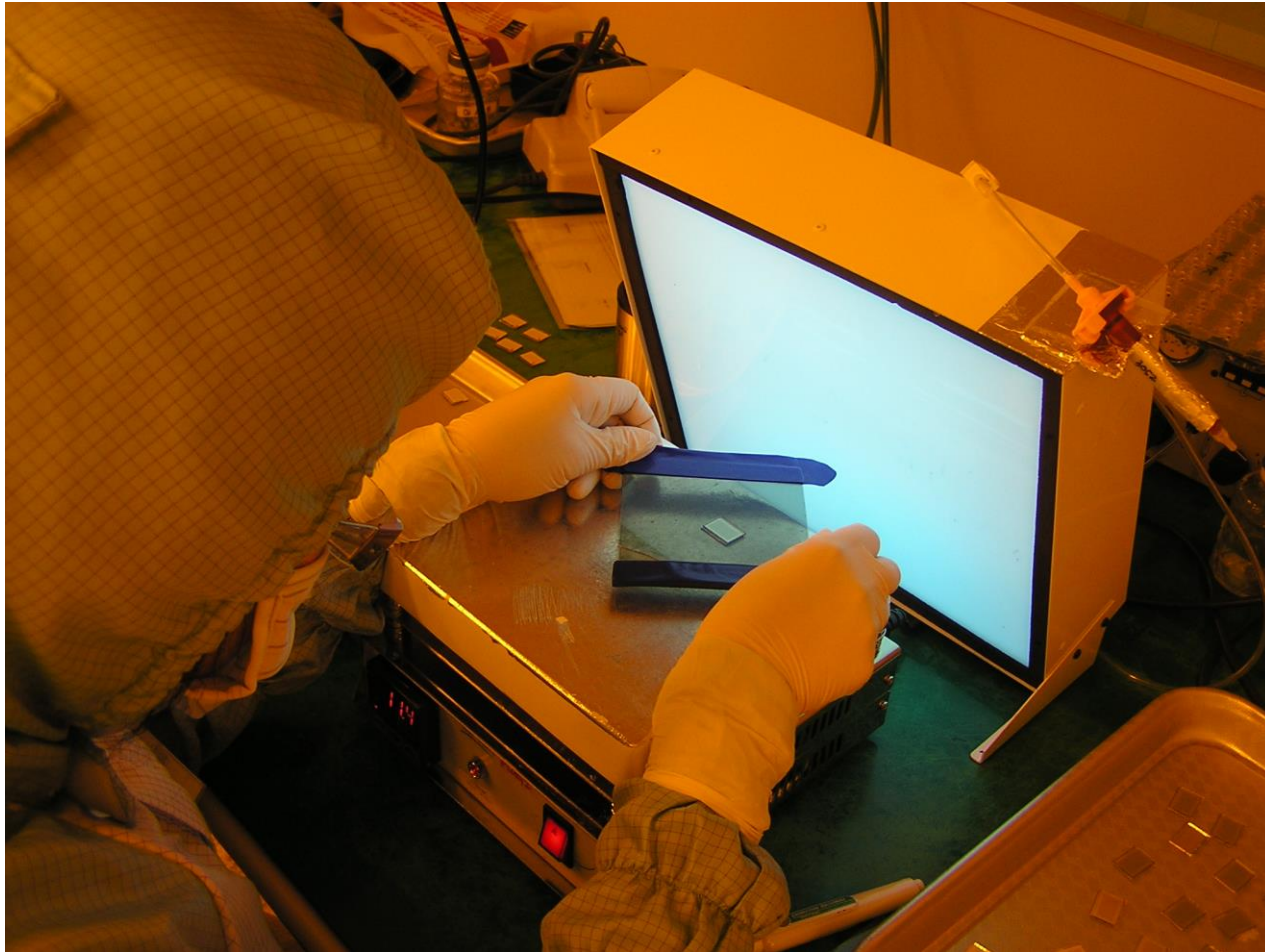

Cell Inspection



ITO Sunbond Connection



Optical Probe Testing

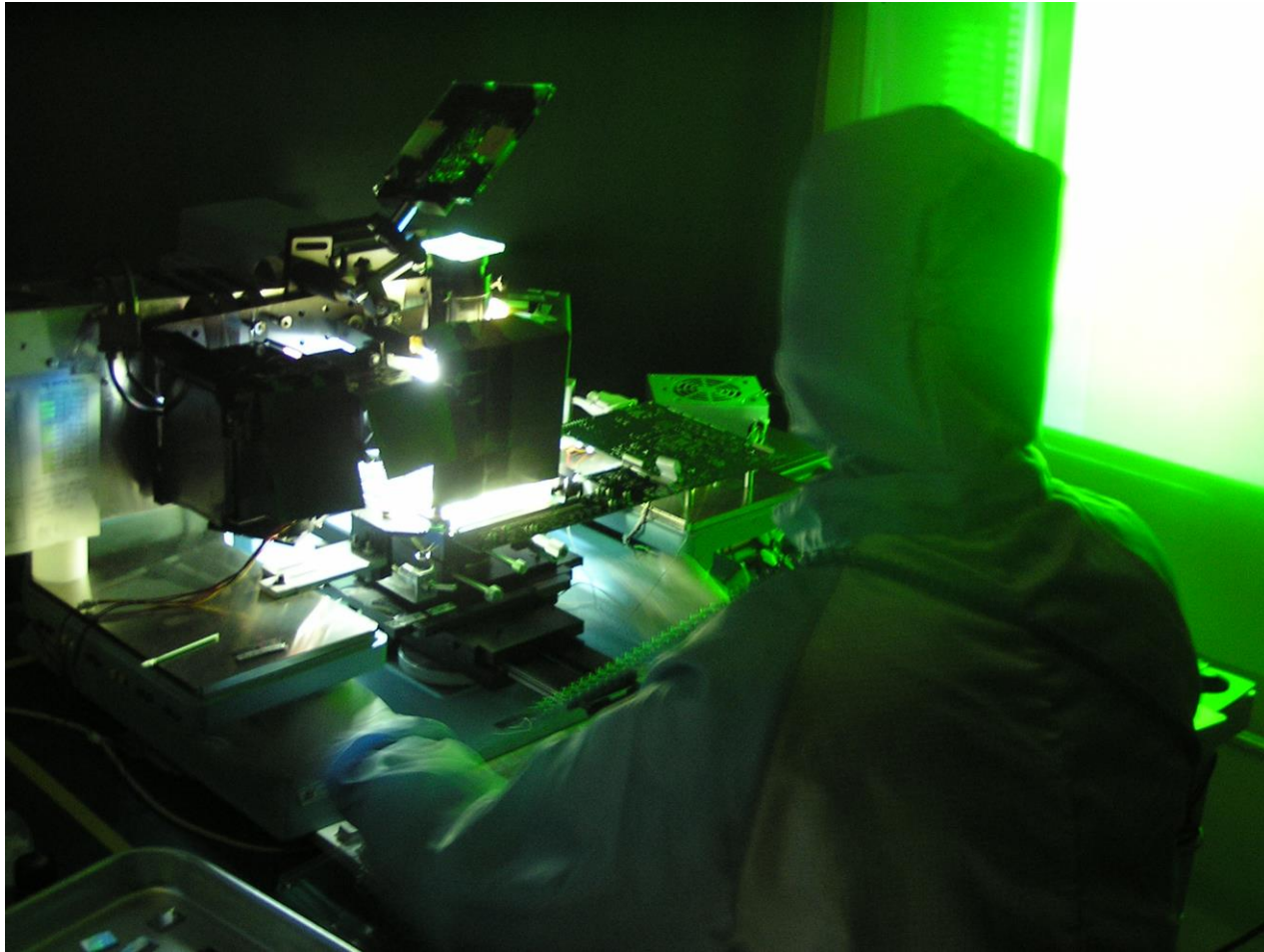

Imager Assembly

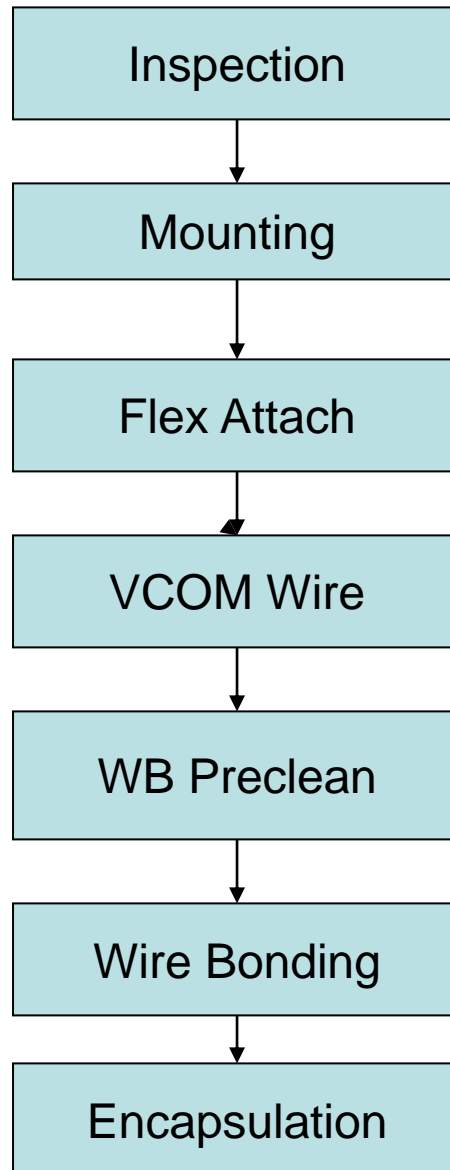

Mounting and Wirebonding



Mount Adhesive Dispense



Cell Mounting



Flex Attach

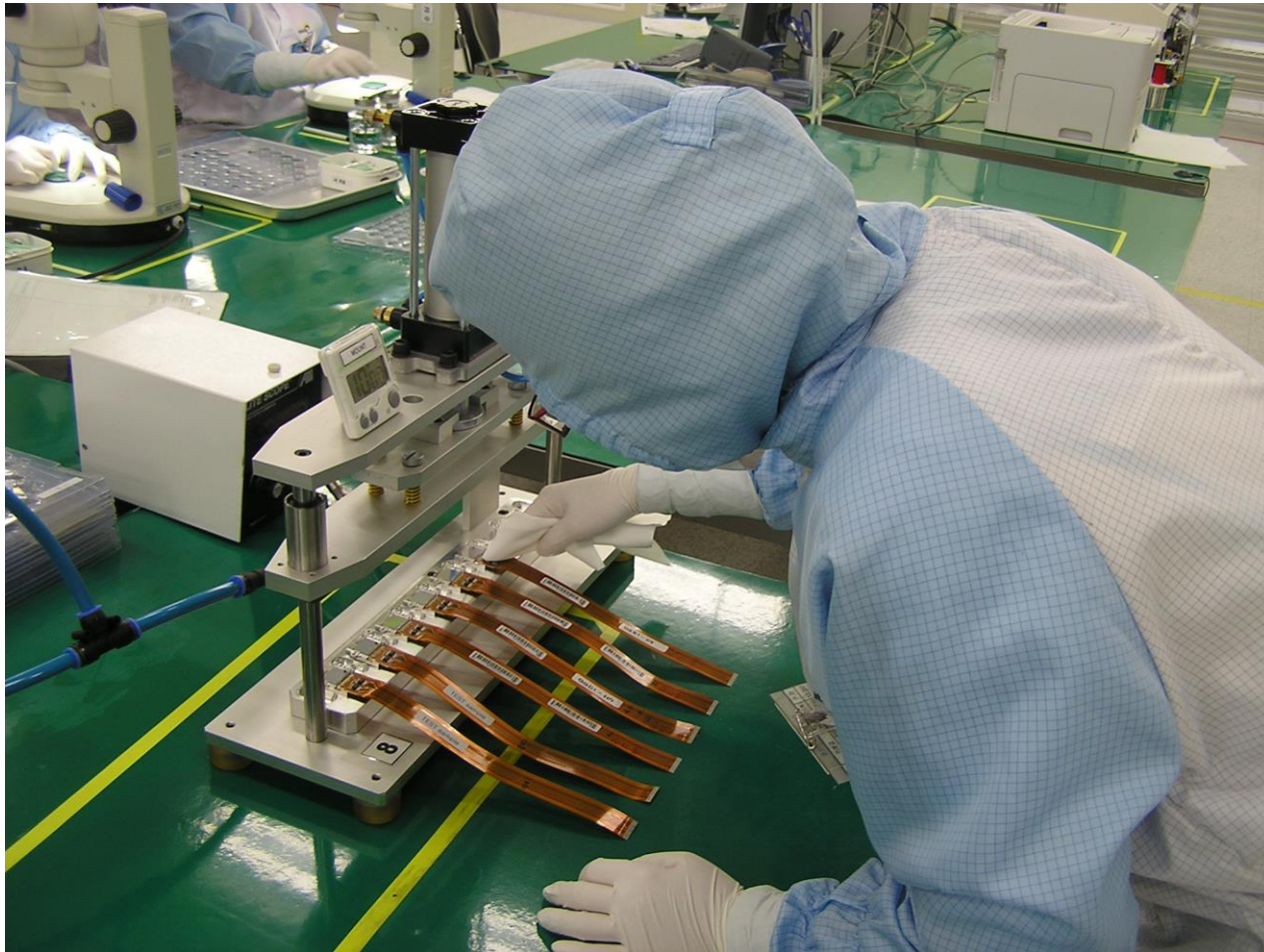

Auto Wire Bonder



Wire Bond Pull Tester

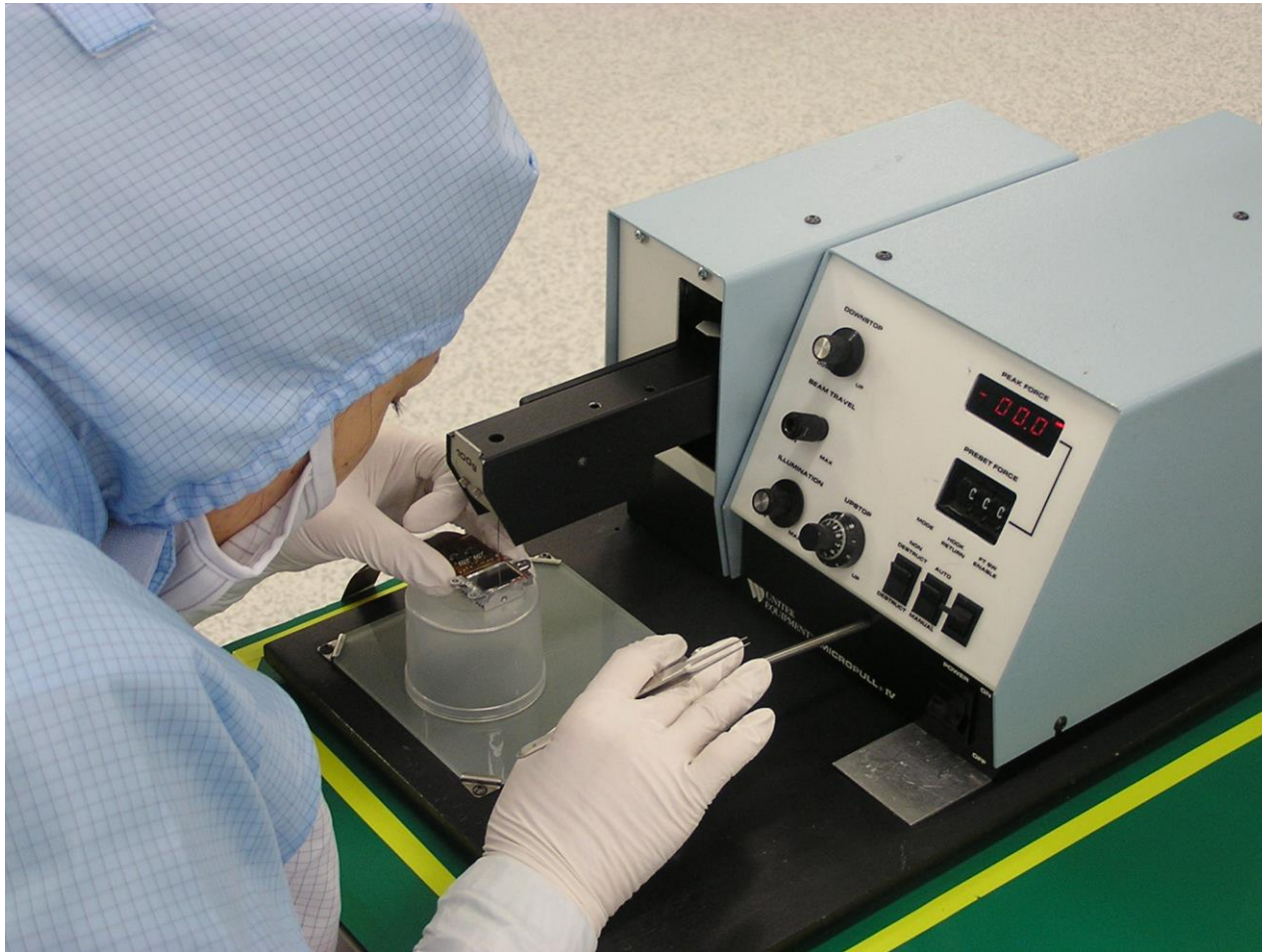

VCOM Wire Auto Stripper



VCOM Wire Attach

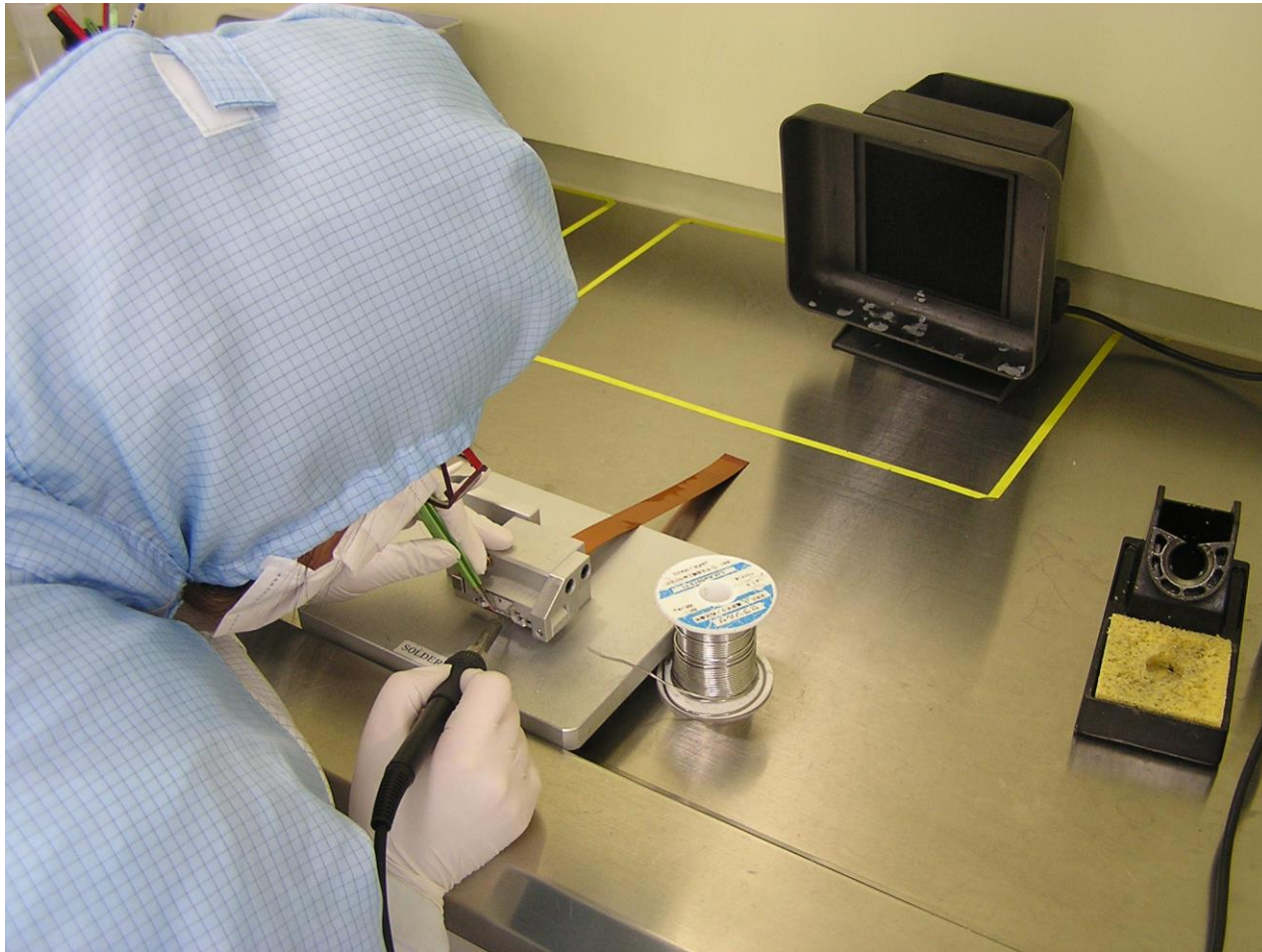

Production Test

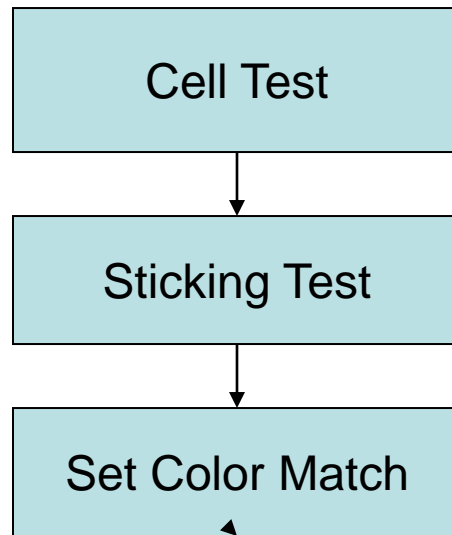

Imager Testing

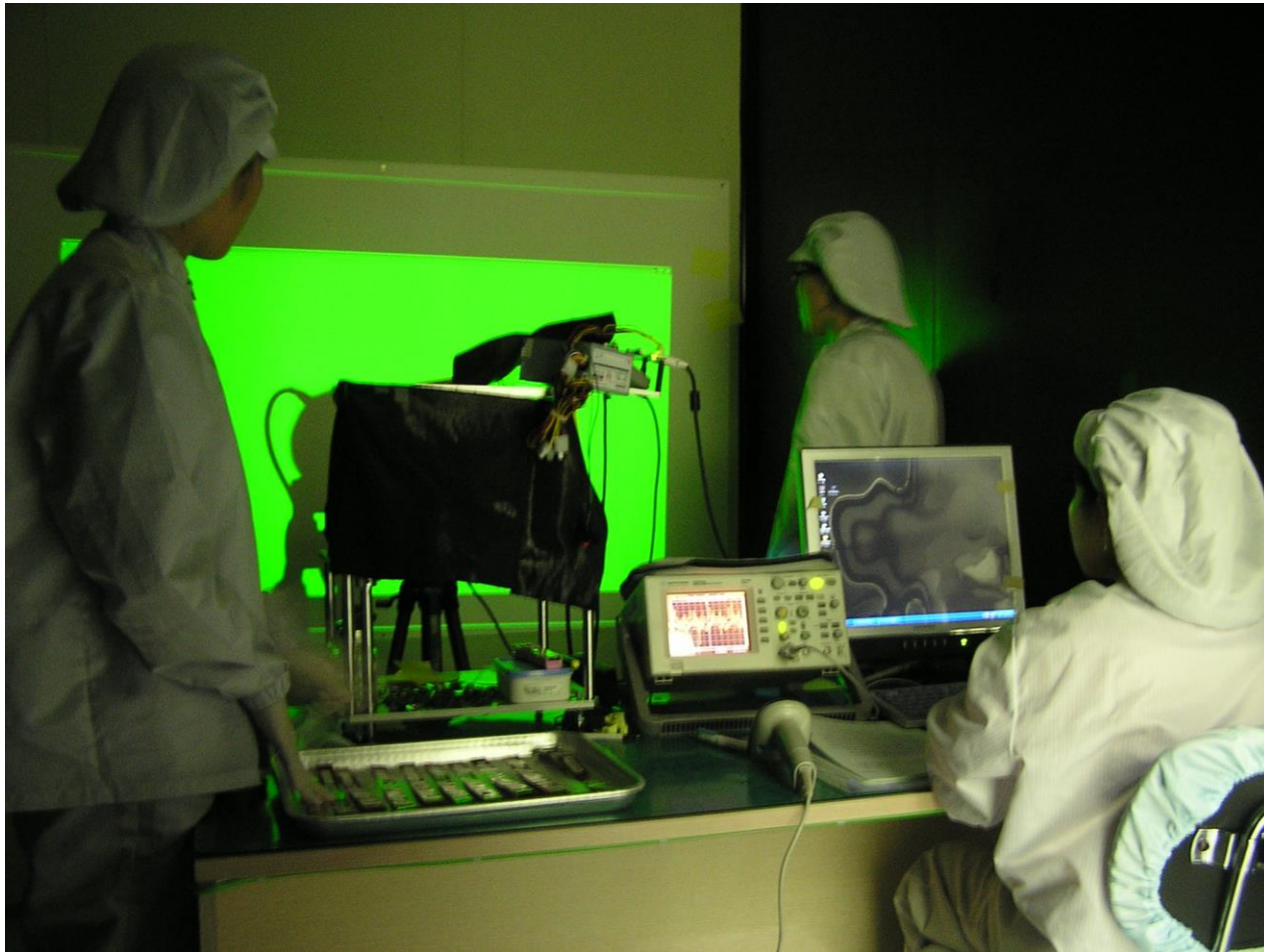

Sticking Sample Test

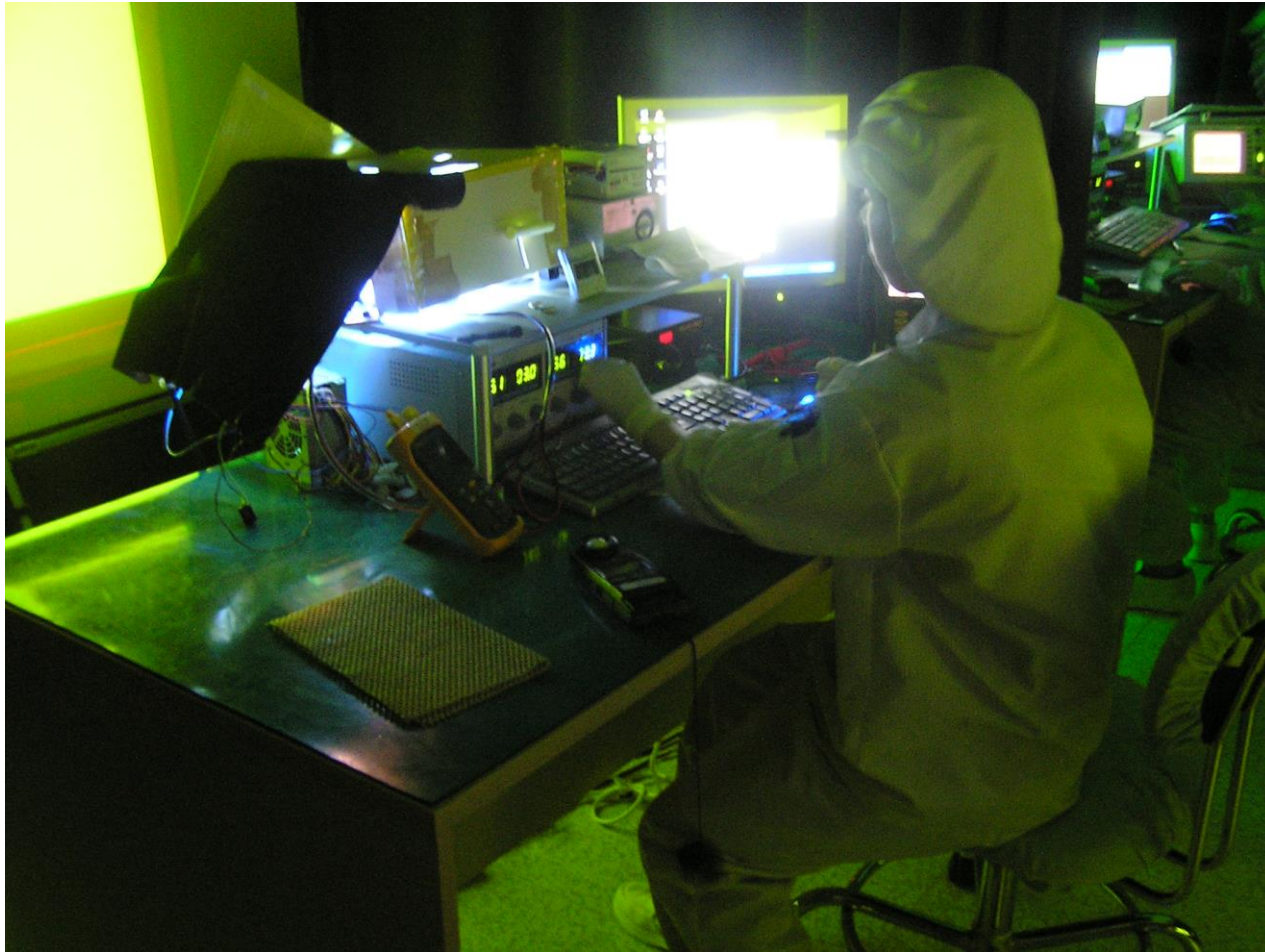

Color Uniformity Check

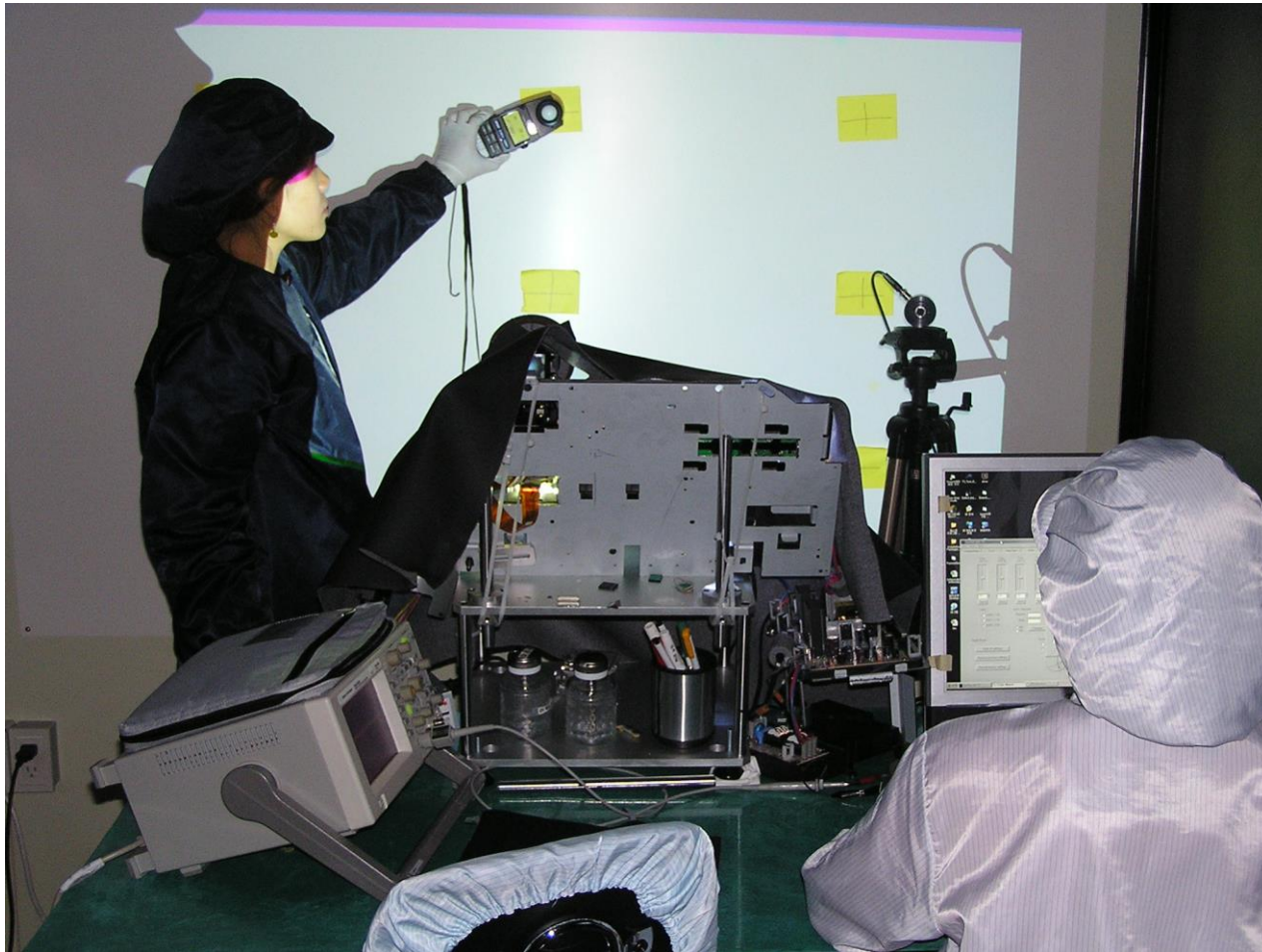

OQC/Pack&Ship

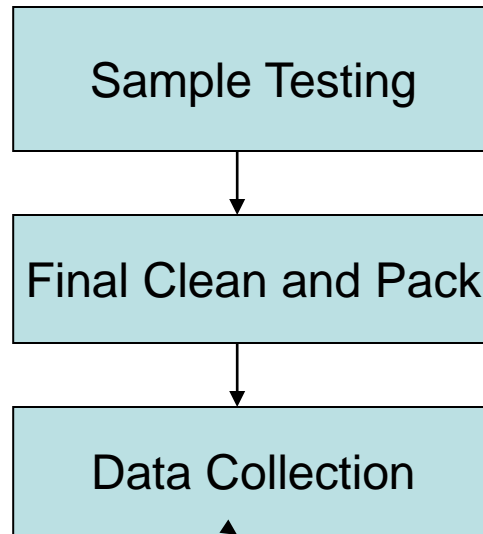

Final Clean and Pack



Vacuum Package Sealer

