

Radiadores

PHAR

2018

**RADIADORES
ALUMINIO-PLÁSTICO**

VERSIÓN

AP 02.18

FEBRERO 2018

ÍNDICE

Guía de uso del Catalogo & Tabla de Conversión.....	04
Guía Rápida de los Radiadores Versión por Marca	05
PHAR Información de los Radiadores	13
PHAR Tractocamión Aluminio-Plástico	152
PHAR Post-enfriadores	157
Guía Rápida de los Radiadores Versión por Código	165
Información Final	171
Garantía	172
Prevención de Fallas Comunes	173
Notas	174



**PROVEEDORA DE HERRAMIENTAS
Y ACCESORIOS PARA RADIADOR, S.A. DE C.V.**

Héroes del 47 No. 3131 Nte. Col. Cementos,
C.P. 64520 Monterrey, N.L. México
Commutator: +52 (81) 8351-2920, Fax: ext.118 & 120
e-mail: webmaster@phar.com.mx, http://www.phar.com.mx



GUÍA DE USO DEL CATALOGO

Código: A0314-26C

Marca: NISSAN

Notas: Tomas lado copiloto

Dibujo: [Technical drawing of radiator]

Referencias: [Technical drawing of radiator]

Medida del Panel*: [Technical drawing of radiator]

Cabeceras: [Technical drawing of radiator]

Notas: [Technical drawing of radiator]

Modelo: PICK UP D21 86-97

Entrada y Salida¹: [Technical drawing of radiator]

Enfriador²: [Technical drawing of radiator]

Número: 0314 DPI/5569 PHAR L4 2.4 V6 30

Motor: [Technical drawing of radiator]

PANAL: 16 7/8" X 25 27/64" X 1 1/8"
 CAB. SUP.: 1 13/16" X 26 5/16"
 CAB. INF.: 1 13/16" X 26 5/16"
 ENF. TRANS.: 756621
 ENF. MOTOR: NO
 NOTAS:

TOMAS:
 ENTRADA: 1 3/8"
 SALIDA: 1 3/8"

496

*En este orden: **ALTURA** (refiere a la distancia entre el borde de la cabecera superior y la cabecera inferior, ó refiere a la distancia entre el borde de la cabecera derecha y la cabecera izquierda), **ANCHURA** (la anchura de la base se mide del final de la aleta al otro extremo y no incluye ESTRUCTURA); y **PROFUNDIDAD** (la profundidad de la base [ESPESOR] refiera a la distancia dentro de la base).

¹Medida de las tomas de entrada y salida (Izquierda, Derecha, Superior e Inferior).

²Enfriador de aceite.

TABLA DE CONVERSION

MILIMETROS	PULGADAS	LINEAS
13 mm	1/2"	1
16 mm	5/8"	1
22 mm	7/8"	1
26 mm	1"	1
28 mm	1 1/8"	2
32 mm	1 1/4"	1
36 mm	1 7/16"	1
44 mm	1 3/4"	3
47 mm	1 7/8"	3
49 mm	2"	3
56 mm	2 1/4"	2
60 mm	2 3/8"	4

CODIGO	APLICACION	AÑOS	DIBUJO /PAGINA
FORD/MERCURY			
A2818-28P7	F-SERIES PICK UP V6 4.2 V8 4.6/5.4	97-04	084/71
A2856-28C	FUSION/MILAN/ZEPHRY L4 2.3 V6 3.6	06-09	085/71
A2936-28N	EDGE / LONCOLN MKX / MKS V6 3.5/3.7	07-10	086/71
A2952-44P7	EXPLORER/MOUNTAINEER V6 4.0 / V8 4.6	07-10	087/71
A7037-28N	FIESTA L4 1.6	00-03	088/71
A8225-44C	BRONCO L6 2.8/3.3 V8 5.0	66-77	089/71
A13022-60C	DIESEL SUPER DUTY V8 6.4	08-10	090/71
A13087-13N	FOCUS L4 2.0	08-11	091/72
0880	TOPAZ/TEMPO L4 2.3	86-91	092/72
0890	TAURUS/SABLE L4 2.5	86-91	093/72
0891	SABLE AMERICANA V6 3.0	86-93	094/72
0893	PICK UP AMERICANA/BRONCO L6 4.9	85-91	095/72
0894	PICK UP AMERICANA L6 4.9	85-92	096/72
0896	BRONCO PICK UP V8 5.0	85-96	097/72
0897	BRONCO/EXPLORER V6 2.8/2.9/3.0/4.0	85-90/91-94	098/72
1115	PROBE V6 3.0	90-92	099/72
1453	F-SERIES/BRONCO V8 5.0/5.8	85-97	100/73
1721	RANGER/B4000 PICK UP V6 4.0	95-97	101/73
1726	RANGER/B2300 L4 2.3	95-97	102/73
2018	EXPLORER/RANGER V6 4.0	97-04	103/73
2610	CROWN VICTORIAL/LINCOLN TOWN CAR/GRAND MARQUIS V8 4.6	03-04	104/73
2741	EXCURSION/PICK UP F-SERIES V8 6.0	03-05/2004	105/73
2762	ESCAPE/TRIBUTE/MARINER L4 2.3	05-08	106/73
2819	F-SERIES PICK UP V8 4.6/5.4	05-08	107/73
2887	F-SERIES PICK UP V8 6.0 V10 6.8	05-08	108/73
2937	EDGE/TAURUS/MKS/MKX/SABLE V6 3.5/3.7	07-15	109/74
2952	EXPLORER/MOUNTAINEER V6 4.0 V8 4.6	07-09/07-08	110/74
2976	E SERIES VAN V8 6.0	04-10	111/74
13041	ESCAPE/TRIBUTE/MARINER V6 3.0	08-12-09/11	112/74
13060	ESCAPE/TRIBUTE/MARINER L4 2.3/2.5	08-12-09/11	113/74
13099	EXPEDITION/F-SERIES 150, 250/LOBO/NAVIGATOR/MARK LT V8 4.6/5.4/6.2	09-14	114/74
13184	TRANSIT CONNECT L4 2.0	10-13	115/74
13201	FIESTA/IKON L4 1.6/2.0	08-15/11-14	116/74
13226	F-150/LOBO/MARK LT V6 3.5/3.7 / V8 5.0	11-14	117/74
13313	ESCAPE/TRANSIT CONNECT L4 1.6/2.0/2.5	13-16	118/75
13321	FUSION/MKZ L4 1.5/1.6/2.0/2.5	13-16	119/75
13331	C-MAX HYBRID L4 2.0 ELECTRIC-GAS	13-15	120/75
13356	EDGE L4 2.0	12-14	121/75
13230-40	F-SERIES 250, 350, 450, 550/SUPER DUTY V8 6.7	11-16	122/75
AA060-60N	TOMS BRONCO L6 2.8/3.3 V8 4.7/5.0	66-77	123/75
AA066-44C	TOMS BRONCO L6 2.8/3.3 V8 4.7/5.0	66-77	124/75
AA067-44C	TOMS BRONCO V8 5.0/5.8	66-77	125/75
AA068-60C	TOMS BRONCO L6 2.8/3.3 V8 4.7/5.0	66-77	126/75
FD-030	FIESTA L4 1.4 TDCi	02-08	127/76
FD-042	KA L4 1.3/1.4	00-07	128/76
LHRP025-2R	MONDEO FORD L41.8/2.0/2.5	00-02	129/76
LHRP205-2R	FIESTA/IKON FORD L4 1.6	00-02	130/76
LHRP348-2R	MONDEO FORD L4 1.8	2007	131/76
LHRP499-26M	MONDEO L4 2.0/2.2 TDCi/TDDi	00-04	132/76
LHRP500	MONDEO V6 2.5/3.0 A.T.	00-02	133/76
LHRP703	MONDEO V6 2.5/3.0 A.T.	00-02	134/76
LHRP704	MONDEO V6 2.5/3.0 A.T.	00-02	135/76
LHRP946	RANGER 3.2L SUPER DIESEL	11-15	136/77
MTC-8238-52P5	CASCADIA L6 12.8/14.8	07-08	137/77
M008-26N	ECOSPORT/FIESTA L4 1.6/2.0	03-09/04-09	138/77
M036-26N	COURIER PICK UP L4 1.6/2.0	93-09	139/77
M1273-26C	ESCORT/TRACER L4 1.8/1.9/2.0	91-02	140/077
M1274-26N	ESCORT/TRACER L4 1.8/1.9/2.0	91-02/91-99	141/077
M2138-26C	MUSTANG V6 3.8/3.9	97-04	142/77
M2139-26C	MUSTANG V8 4.6	97-04	143/77
M2140-26C	ESCORT Zx2 L4 2.0	00-00	144/077
M2141-26C	F-SERIES/EXPEDITION/LOBO V8 4.2/4.6	97-98	145/78
M2258-26P7	FREESTAR/WINDSTAR/MONTEREY V6 3.0/3.8/3.9/4.2	04-07	146/78
M2296-26N	FOCUS L4 2.0/2.3	00-07	147/78
M2818-26P7	EXPEDITION/F-SERIES/MARK LT/LOBO/NAVIGATOR V6 4.2 V8 4.6/5.4	05-08	148/78
FREIGHTLINER			
A8022-44N	BUSINESS CLASS M2/CENTURY CLASS C112-C120 L6.5/9/6.3/10.8/12.0/12.7	04-12/96-01	149/78
GEO			
1409	PRIZM/COROLLA L4 1.6/1.8	93-97	001/80
2089	TRACKER X-90 L4 1.6	94-98	002/80
2198	PRIZM/COROLLA L4 1.8	98-02	003/80

CODIGO	APLICACION	AÑOS	DIBUJO /PAGINA
HONDA			
A0019-28C	ACCORD/PRELUDE L4 2.2	90-93/92-96	004/80
A0928-28C	ACCORD L4 2.0	86-89	005/80
A1494-13C	ACCORD/ACURA CL L4 2.2/2.3	91-99	006/80
A1776-13C	ACCORD/ACURA CL V6 2.7/3.0	95-97/97-99	007/80
A1776-28C	ACCORD/ACURA CL V6 2.7/3.0	95-97/97-99	008/80
A1940-28N	ACCORD/PRELUDE L4 2.2	91-93/92-96	009/80
A2147-13C	ACCORD/TL ACURA V6 3.0/3.2	99-02	010/81
A2274-28C	CIVIC/EL ACURA L4 1.5/1.6	99-00	011/81
A2274-28N	CIVIC/EL ACURA L4 1.5/1.6	99-00	012/81
A2354-13C	CIVIC/ACURA/EL L4 1.7	01-05	013/81
A2443-13C	CR-V/ELEMENT L4 2.4	02-06	014/81
A2569-13C	ACCORD L4 2.4	03-04	015/81
A2571-13N	ACCORD V6 3.0	03-07	016/81
A2783-13C	ACCORD V6 3.0	05-07	017/81
A2922-13N	CIVIC/ACURA CSX L4 1.8/2.0	06-07/06-11	018/81
A2923-13C	CIVIC/ACURA CSX L4 1.3/2.0	06-07/06-11	019/82
A2954-13C	CR-V L4 2.4	07-09	020/82
A13031-13C	CR-V L4 2.4	07-09	021/82
A13065-28C	PILOT / RIDGELINE V6 3.5	09-14	022/82
A13221-13N	CIVIC/ILX L4 1.8/2.4	12-15	023/82
A13314-13N	CR-V L4 2.4	12-14	024/82
0019	ACCORD/PRELUDE L4 2.2	93-96	025/82
0886	CIVIC-CRX L4 1.5/1.6	88-91	026/82
1571	PASSAPORT/RODEO V6 3.2/3.5	93-01	027/82
1815	ODYSSEY/OASIS L4 2.2/2.3	95-98	028/83
2051	CRV L4 2.0	97-01	029/83
2148	ACCORD L4 2.3	98-02	030/83
2195	PASSAPORT/RODEO V6 3.2/3.5	98-03	031/83
2203	ACCORD L4 2.3	98-02	032/83
2270	ODYSSEY/OASIS L4 2.3 V6 3.5	99-03	033/83
2355	CIVIC L4 1.7	01-05	034/83
2417	PILOT/MDX V6 3.5	03-04	035/83
2569	ACCORD L4 2.4	03-04	036/83
2572	CIVIC/HYBRID L4 1.3	03-05	037/84
2574	CIVIC L4 2.0	02-05	038/84
2599	ACCORD 4 CIL. L4 2.4	03-05	039/84
2740	MDX/PILOT V6 3.5	03-06/2005	040/84
2797	ACCORD AT L4 2.4	05-07	041/84
2806	ODYSSEY V6 3.5	05-09	042/84
2830	RIDGELINE V6 3.5	06-08	043/84
2955	FIT L4 1.5	07-08	044/84
2956	PILOT V6 3.5	06-08	045/84
13065	PILOT/RIDGELINE V6 3.5	09-14	046/85
13068	FIT L4 1.5	09-13	047/85
13155	CR-V L4 2.4	10-11	048/85
13161	CR-V L4 2.4	10-11	049/85
13208	ODYSSEY V6 3.5	11-15	050/85
13221	CIVIC/ILX L4 1.8/2.4	13-14	051/85
13257	CIVIC/ILX L4 1.5/1.8	12-15	052/85
13451	FIT L4 1.5	15-17	053/85
13539	HR-V L4 1.8	16-17	054/85
M2274-26C	CIVIC/EL L4 1.5/1.6	92-00	055/86
M2274-26N	CIVIC/EL L4 1.5/1.6	92-00	056/86
LHRP176	ODYSSEY V6 3.5 A.T.	05-06	057/86
LHRP349-1R	ACCORD/ROX V6 3.5	08-12/13	058/86
LHRP555	ACCORD/CROSSTOUR L4 2.4	08-14/12-14	059/86
LHRP556	FIT L4 1.5	09-13	060/86
LHRP557	ODYSSEY L4 2.4	10-13	061/86
HYUNDAI			
A034-28N	H100 STD L4 2.5/2.6	99-07	062/86
A2600-13C	ATTITUDE/ACCENT/VERNA L4 1.5/1.6	00-06	063/86
A6031-28N	ATOS L4 1.0i	00-04	064/87
1823	SONATA L4 2.0 V6 3.0	95-98	065/87
1897	ELANTRA/TIBURON (ST. & AT.) L4 1.8/2.0	96-01	066/87
13150	TUCSON/SPORTAGE L4 2.0/2.4	10-15	067/87
13252	ATTITUDE/ACCENT-VELOSTER/KIA RIO L3 1.2/ L4 1.4/1.6	12-16	068/87
13253	ATTITUDE/ACCENT/KIA RIO L3 1.2/ L4 1.4/1.6	12-16	069/87
13373	SANTA FE L4 2.0	13-17	070/87
2896-2	ATTITUDE/VERNA/ACCENT L4 1.5/1.6	06/10	071/87
LHRP185	ACCENT/VERNA L4 1.6i	1999	072/87
LHRP532	H-100 L4 2.5 MOTOR DIESEL	06-11	073/88

CODIGO	APLICACION	AÑOS	DIBUJO /PAGINA
HYUNDAI			
LHRP589-1	GRAND I10 1.0/1.2	15-16	074/88
LHRP665-2	Lx35 L4 2.0	09-15	075/88
INFINITI			
1752	i130 /MAXIMA V6 3.0	95-00	001/90
2054	Q45 V8 4.1/4.5	96-01	002/90
2426	Q45/M45 V8 4.5	02-06	003/90
2459	QX4/PATHFINDER V6 3.5	01-04	004/90
ISUZU			
1571	RODEO/PASSAPORT V6 3.2/3.5	93-01	005/90
2195	RODEO/PASSAPORT V6 3.2/3.5	98-04	006/90
2445	AXIOM V6 3.5	02-04	007/90
JAGUAR			
2622	X-TYPE V6 2.5/3.0	02-08	008/90
JEEP			
A1193-28C	CHEROKEE L4 2.5 L6 4.0	91-01	009/90
A1394-28C	GRAND CHEROKEE L6 4.0	93-97	010/91
A1396-28C	GRAND CHEROKEE L6 4.0	93-97	011/91
A2101-28C	WRANGLER/TJ L4 2.4/2.5 L6 4.0	97-06	012/91
A2262-28C	GRAND CHEROKEE L6 4.0	99-04	013/91
A2263-28P6	GRAND CHEROKEE V8 4.7	99-02	014/91
A2336-28C	GRAND CHEROKEE V8 4.7	01-04	015/91
A2340-28C	CHEROKEE L6 4.0	91-01	016/91
A2481-28P5	LIBERTY V6 3.7	02-06	017/91
A2839-28N	CHEROKEE / COMANDER V6 3.0/3.7 V8 4.7/6.1	05-10/06-10	018/91
A2910-28P5	LIBERTY V6 3.7	02-06	019/92
A2951-13N	COMPAS / AVENGER L4 2.4 V6 2.7/3.5	07-12	020/92
A13071-28N	LIBERTY V6 3.7	08-13	021/92
A13200-13N	DURANGO / GRAND CHEROKEE V6 3.6 / V8 5.7	11-14/11-15	022/92
1682	WRANGLER L4 2.5 L6 4.0/4.2	87-95	023/92
2340	CHEROKEE/WAGONER L6 4.0	91-01	024/92
2840	GRAND CHEROKEE/COMMANDER V8 5.7	05-10/06-10	025/92
2957	WRANGLER V6 3.6/3.8	07-11	026/92
AT2340-28C	CHEROKEE SPORT L6 4.0	91-01	027/92
M1193-26C	CHEROKEE L6 2.5/4.0	07-11	028/93
M2340-26C	CHEROKEE/WAGONER L6 4.0	91-01	029/93
M2481-26P5	LIBERTY V6 3.7	02-06	030/93
M2910-26P5	LIBERTY V6 3.7	02-06	031/93
KIA			
13150	TUCSON/SPORTAGE L4 2.0/2.4	10-15	001/96
LEXUS			
A2581-28C	4 RUNNER / Gx470 V8 4.7	03-09	002/96
A13035-13C	CAMRY / ES350 L4 2.4 / V6 3.5	07-11/07-12	003/96
1746	ES300 CAMRY/AVALON V6 3.0	94-99	004/96
1918	LX450/TOYOTA LAN CRUISER L6 4.5	93-97	005/96
LINCOLN			
2435	ES300/CAMRY V6 3.0/3.3	02-03	006/96
A1729-28C	CONTINENTAL V8 4.6	95-02	007/96
A2603-28N	AVIATOR V8 4.6	03-05	008/96
A2719-44P7	LOBO/F150/F250/F350/NAVIGATOR/BLACKWOOD V8 4.6/5.4	03-04/03-06	009/96
A2856-28C	FUSION / MILAN / ZEPHYR L4 2.3 V6 3.0	09-12	010/97
2819	MARK LT V8 5.4	05-08	011/97
2937	EDGE/TAURUS/MKS/MKX/SABLE V6 3.5/3.7	07-15	012/97
13045	EXPEDITION/NAVIGATOR V8 5.4	07-09	013/97
13099	EXPEDITION/F-SERIES 150, 250/LOBO/NAVIGATOR/MARK LT V8 4.6/5.4/6.2	09-14	014/97
13226	F-150/LOBO/MARK LT V6 3.5/3.7 / V8 5.0	11-14	015/97
13321	FUSION/MKZ	13-16	016/97
MACK			
ATE8075-44P5	CNX VISION/VN SERIES AUT 800040, VOL40, 239311, 80040WF, 2001-4605		017/97
MAZDA			
A1323-28C	626/MX L4 2.0/2.2	93-97/92/97	001/100
A1726-28C	RANGER/F100/MAZDA B2300 L4 2.3	95-97/96-97	002/100
A1735-28C	B3000 PICK UP V6 3.0	85-94	003/100
A2306-26C	ESCAPE/TRIBUTE DX L4 2.0	01-04	004/100
A2307-26C	ESCAPE/TRIBUTE DX V6 3.0	01-08/01-08	005/100
A2470-28C	B2300/RANGER L4 2.3	01-10/01-12	006/100
A2696-28N	MAZDA 3/FOCUS L4 2.0/2.3	04-09/09-11	007/100
A2918-28C	CX-7 L4 2.3/2.5	07-11	008/100
A13088-28C	MAZDA 6 L4 2.5	09-10	009/100
A13100-13N	MAZDA 3 L4 2.0/2.3/2.5	09-12	010/101
A13233-13N	MAZDA 2 L4 1.5	11-12	011/101
A13262-13N	MAZDA 3 L4 2.0/2.3/2.5	11-13	012/101

CODIGO	APLICACION	AÑOS	DIBUJO /PAGINA
MAZDA			
1244	MPV VAN L4 2.6 V6 3.0	89-95	013/101
1323	626/MX6 SPORT COUPE L4 2.0/2.2	92-97	014/101
1326	MX-6/626 (26 AT) V6 2.5	93-97	015/101
1704	323/PROTEGE L4 1.5/1.8	95-98	016/101
2063	MPV V6 3.0	96-98	017/101
2303	PROTEGE 5 L4 1.6/1.8/2.0	99-03	018/101
2330	MPV VAN V6 2.5	00-01	019/102
2672	MAZDA 6 V6 3.0	03-08	020/102
2673	MAZDA 6 L4 2.3	03-08	021/102
2762	ESCAPE/TRIBUTE/MARINER L4 2.3	05-08	022/102
2768	MPV VAN V6 3.0	02-06	023/102
2894	MAZDA 5 L4 2.3	06-10	024/102
2986	CX-9 V6 3.5/3.7	07-15	025/102
13089	MAZDA 6 L4 2.5 V6 3.7	09-10	026/102
13317	CX-5 L4 2.0/2.5	13-16	027/102
13404	3 L4 2.0/2.5	14-16	028/103
LHRP841	3 L4 1.6/1.8	10-13	029/103
MERCEDES BENZ			
A007-44C	SPRINTER L5 2.7 V6 3.0/3.5	04-09	030/103
A2796-28C	SPRINTER L5 2.7 V6 3.0	04-09	031/103
A2796-44C	SPRINTER L5 2.7 V6 3.0/3.5	04-09	032/103
2290	E320 V6 3.2	98-02	033/103
2337	C230, C240, C320 V6 2.5/3.0/3.2/3.5	01-06	034/103
2751	CLK350 / SLK300 / SLK350 V6 3.0/3.5 V8 5.5	08-11	035/103
2868	E320/E350 V6 3.2/3.5 L6 3.2	03-06/2006	036/103
13254	SPRINTER V6 3.0/3.5	07-13	037/104
MINI			
2747	MINI COOPER L4 1.6	02-05	038/104
MITSUBISHI			
A2410-28C	SEBRING/STRATUS/CIRRUS/ECLIPSE V6 2.7/3.0	01-06/00-05	039/104
A2675-13C	ENDEAVOR V6 3.8	04-11	040/104
A2675-28C	ENDEAVOR V6 3.8	04-11	041/104
A2842-13C	ECLIPSE L4 2.4 V6 3.8	06-12	042/104
A2883-28C	RAM/RAIDER V6 3.7 V8 4.7	05-10/06-09	043/104
A2978-28N	LANCER/OUTLANDER L4 2.0/2.4 V6 3.0	07-15	044/104
A2979-13N	LANCER / OUTLANDER L4 2.0/2.4 V6 3.0	04-14/10-13	045/104
1145	ECLIPSE/LASER/TALON L4 1.8/2.0	90-94	046/105
1393	MIRAGE/LOLT L4 1.5/1.8	93-96	047/105
1906	DIAMANTE V6 3.5	97-04	048/105
1907	MIRAGE L4 1.5/1.8	97-02	049/105
2023	SERVING/ECLIPSE L4 2.0	95-97/99	050/105
2024	TALON/ECLIPSE L4 2.0	95-98/99	051/105
2071	MONTERO SPORT V6 3.0	97-99	052/105
2073	MONTERO SPORT L4 2.4	97-00	053/105
2278	MONTERO SPORT V6 3.0/3.5	97-03	054/105
2300	GALANT L4 2.4	99-02	055/106
2301	GALANT V6 3.0	99-02	056/106
2406	ECLIPSE L4 2.4	2000	057/106
2448	LANCER L4 2.0/2.4	02-07	058/106
2468	MONTERO V6 3.5	01-02	059/106
2617	OUTLANDER L4 2.4	03-06	060/106
2676	LANCER EVOL L4 2.0	03-06	061/106
2752	MONTERO/LANCER V6 3.8	03-04/04	062/106
2978	OUTLANDER/LANCER L4 2.0/2.4 V6 3.0	07-13	063/106
2979	LANCER/OUTLANDER L4 2.0/2.4 V6 3.0	04-13	064/107
13469	MIRAGE L3 1.2	14-17	065/107
LHRP169	L200 (TRITON) V6 3.5	05-06	066/107
NISSAN			
A001-13N	D-22 PICK UP GASOLINA M/T L4 1.6/1.8/2.2i	07-09	001/110
A001-28C	D-22 PICK UP GASOLINA A/T L4 1.6/1.8/2.2i	07-09	002/110
A001-28N	D-22 PICK UP GASOLINA M/T L4 1.6/1.8/2.2i	07-09	003/110
A002-13N	PICK UP DIESEL M/T L4 2.5	07-09	004/110
A002-28N	PICK UP DIESEL M/T L4 2.5	07-09	005/110
A027-28N	CABSTAR L4 2.5	07-08	006/110
A027-44N	CABSTAR L4 2.5 Diesel	07-08	007/110
A038-44P7	MONTACARGAS	90-11	008/110
A047-13C	TIIDA L4 1.6/1.8	07-13	009/110
A0314-13C	PICK UP D21 L4 2.4 V6 3.0	86-07	010/111
A0314-13N	PICK UP D21 L4 2.4 V6 3.0	86-97	011/111
A0314-26C	PICK UP D21/PATHFINDER/PICK CP L4 2.4 V6 3.0	86-94/87-95 95-04	012/111
A0314-26N	PICK UP D21/PATHFINDER/PICK UP L4 2.4 V6 3.0	86-94/87-95 95-04	013/111

CODIGO	APLICACION	AÑOS	DIBUJO /PAGINA
NISSAN			
A1152-26C	SENTRA/200sx/TSURU/TSUBAME L4 1.6/1.8/2.0	91-99/96-98 91-15/95-04	014/111
A1152-28C	TSURU/SENTRA/TSUBAME/200SX L4 1.6/2.0	91-99/95-98	015/111
A1242-28C	300ZX/MAXIMA V6 3.0	89-96/89-94	016/111
A1426-13C	TSURU/SENTRA L4 1.6/2.0	91-99	017/111
A1426-13N	TSURU/SENTRA L4 1.6/2.0	91-99	018/111
A1426-26N	SENTRA/TSURU L4 1.6/2.0	93-09	019/112
A1426-26C	TSURU/SENTRA L4 1.6/2.0	91-99	020/112
A1511-28C	QUEST/VILLAGER V6 3.0	93-95	021/112
A1573-28C	ALTIMA L4 2.4	93-00	022/112
A1573-28N	ALTIMA L4 2.4	93-00	023/112
A1752-28C	INFINITI/MAXIMA V6 3.0	96-99/95-99	024/112
A1924-28C	QUEST/VILLGAER V6 3.0	96-98	025/112
A1976-26C	SENTRA/LUCINO/TSURU L4 1.6/1.8/2.0	94-00	026/112
A1976-28C	LUCINO/TSURU L4 2.0	95-98	027/112
A1978-26N	SENTRA/LUCINO/TSURU L4 1.6/1.8/2.0	94-00	028/113
A1978-28N	LUCINO/TSURU L4 2.0	95-98	029/113
A2151-28N	XTERRA/FRONTIER V6 3.3	00-04/98-44	030/113
A2215-28C	FRONTIER/XTERRA L4 2.4 V6 3.3	00-04/98-44	031/113
A2327-13N	SENTRA L4 1.8	00-06	032/113
A2327-28N	SENTRA L4 1.8	00-06	033/113
A2328-28C	SENTRA L4 2.0	02-06	034/113
A2329-28C	MAXIMA/130/135 V6 3.0/3.5	00-03/00-04	035/113
A2346-13C	SENTRA L4 1.8	00-06	036/113
A2346-28C	SENTRA L4 1.8	00-06	037/114
A2414-28C	ALTIMA L4 2.5	02-06	038/114
A2469-13C	SENTRA L4 2.5	02-06	039/114
A2469-28C	SENTRA L4 2.5	02-06	040/114
A2576-13C	BASE/TOURING/TRACK/ENTHUSIAST/350Z V6 3.5	03-06/04/06	041/114
A2577-13N	BASE/TOURING/TRACK/ENTHUSIAST/350Z V6 3.5	03-06/04/06	042/114
A2692-28C	QUEST V6 3.5	04-09	043/114
A2691-44C	QX/PATHFINDER/ARMADA/TITAN V6 4.0 V8 5.6	04-10/04	044/114
A2578-28C	MURANO V6 3.5	03-07	045/114
A2981-13C	TIIDA / VERSA L4 1.6/1.8	07-11	046/115
A2998-13N	SENTRA L4 2.0/2.5	07-12	047/115
A5571-28C	TSURU III L4 1.6 8V.	94-02	048/115
A6207-28N	PLATINA/CLIO M/T L4 1.6	02-04	049/115
A6212-28N	URVAN L4 2.4/2.5	01-04	050/115
A6218-28C	X-TRAIL L4 2.0/2.3/2.5	03-04	051/115
A13260-13C	MARCH/MICRA/NOTE/TIIDA/VERSA L4 1.6/1.8	15-17/14-17 12-17	052/115
A13261-13N	MARCH/MICRA/NOTE/TIIDA/VERSA L4 1.6/1.8	15-17/14-17 12-17	053/115
0788	SENTRA/PULSAR/TRURU II L4 1.6	89-90	054/115
1751	240SX L4 2.4	95-98	055/116
1752	MAXIMA /i 130 V6 3.0	95-00	056/116
2054	Q45 V8 4.1/4.5	96-01	057/116
2055	PATHFINDER V6 3.3	96-00	058/116
2075	PATHFINDER V6 3.3	96-00	059/116
2150	ALTIMA L4 2.4	99-02	060/116
2151	FRONTIER/XTERRA L4 2.4 V6 3.3	98/00-04	061/116
2328	SENTRA L4 2.0	00-01	062/116
2333	ALTIMA L4 2.4	00-01	063/116
2415	ALTIMA V6 3.5	02-06	064/117
2459	PATHFINDER/QX4 V6 3.5	01-04	065/117
2576	350Z (AT.) V6 3.5	03-06	066/117
2577	350Z (ST.) V6 3.5	03-04	067/117
2693	MAXIMA/ALTIMA V6 3.5	04-06	068/117
2807	FRONTIER/PATHFINDER/XTERRA V6 4.0 V8 5.6	05-13	069/117
2808	FRONTIER/PATHFINDER/XTERRA L4 2.5	05-13	070/117
2981	VERSA L4 1.6/1.8	07-11	071/117
2988	ALTIMA/MAXIMA L4 2.5	07-13/09/13	072/117
13005	MAXIMA V6 3.5	07-08	073/118
13039	MURANO/QUEST V6 3.5	09-13	074/118
13047	ROGUE L4 2.5	08-13	075/118
13260	VERSA/TIIDA L4 1.6/1.8 AUT	12-15	076/118
13261	VERSA/TIIDA/NOTE L4 1.6/1.8 STD	12-15	077/118
13264	JUKE L4 1.6	11-15	078/118
13365	SENTRA L4 1.8	13-16	079/118
I15433-16N	D23 NP 300 NAVARA GASOLINA 2.5 / DIESEL 2.3	15-18	080/118
LHRP173	TIIDA L4 1.6/1.8	07-13	081/118
LHRP287	MICRA/K12 L4 1.0/1.2/1.4	05-07	082/119
LHRP305-2R	PATHFINDER V6 4.0 V8 5.6	2005	083/119
LHRP444	ALMERA 1.8/2.0i 16V	00-09	084/119
NISSAN			
LHRP527	X-TRAIL L4 2.0/V6 2.5	08-11	085/119
LHRP810	TSURU II L4 1.6	88-91	086/119
LHRP-1065-16	TIIDA/VERSA/NOTE L4 1.6/1.8	12-15	087/119
M0314-26C	PICK UP D21/PATHFINDER/PICK UP L4 2.4 V6 3.0	86-94/87-95 95-04	088/119
M0314-26N	PICK UP D21/PATHFINDER/PICK UP L4 2.4 V6 3.0	86-94/87-95 95-04	089/119
OLDSMOBILE			
A1051-28C	REGAL CUSTOM/LUMINA/GRAND PRIX/CUTLASS V6 3.1/3.4/3.8	90-93	090/119
A1206-28C	REGAL CUSTOM/LUMINA/GRAND PRIX/CUTLASS SUPREME V6 3.1	90-93	091/120
A1216-28C	LUMINA/GRAND PRIX/CUTLASS SUPREME V6 3.1/3.4	91-93	092/120
A1344-28C	SKYLARK/BERETTA/CORSICA/ACHIEVA/GRAND AM L4 2.2/2.3 V6 3.1	92-93	093/120
A1888-28P3	SILHOUETTE/VENTURE V6 3.4/3.8	97-00	094/120
A1889-13P3	SILHOUETTE/VENTURE V6 3.4/3.8	97-00	095/120
A2728-13C	AZTEK/VENTURE/IMPALA V6 3.4/3.5	01-05	096/120
1202	BONEVILLE/REGENCY V6 3.8	91-99	097/120
1476	TRANS SPORT/LUMINA APV V6 3.8	92-95	098/120
1518	LUMINA/CUTLASS/KESAL V6 3.1/3.8	94-97	099/120
PEUGEOT			
1684	LESABRE/REGENCY/88 V6 3.8	96-99/97-98	100/121
LHRP-099	PARTNER/307 M/T L4 2.0	04/02-03	101/121
LHRP184	306 M.T./A.T. L4 1.8/1.9/2.0	08-12	102/121
LHRP291	206/C4	2004	103/121
LHRP451	306 L4 1.6	98-02	104/121
LHRP480	207/307/PARTNER L4 1.6	98-00	105/121
PG-009	206 L4 1.1/1.4/1.6	98-04	106/121
PLYMOUTH			
A1125-28C	VOYAGER/CARAVAN/TOWN COUNTRY L4 2.5 V6 3.0	90-92	001/124
A1387-44C	CARAVAN/VOYAGER V6 3.0	91-92	002/124
PONTIAC			
A009-28N	MATIZ L4 1.0	04-06	003/124
A0768-28C	CAVALIER/ SUNBIRD V6 2.8/3.1	89-94/91-94	004/124
A1051-28C	REGAL CUSTOM/LUMINA/GRAND PRIX/CUTLASS V6 3.1/3.4/3.8	90-93	005/124
A1206-28C	REGAL CUSTOM/LUMINA/GRAND PRIX/CUTLASS SUPREME V6 3.1	90-93	006/124
A1216-28C	LUMINA/GRAND PRIX/CUTLASS SUPREME V6 3.1/3.4	91-93	007/124
A1344-28C	SKYLARK/BERETTA/CORSICA/ACHIEVA/GRAND AM L4 2.2/2.3 V6 3.1	92-93	008/124
A1485-28C	FIRE BIRD V6 3.4/3.8	93-02	009/124
A1687-28N	CAVALIER/SUNFIRE L4 2.2/2.3/2.4	95-02	010/125
A1888-28P3	VENTURE/SILHOUETTE V6 3.4	97-00	011/125
A1889-13P3	VENTURE/SILHOUETTE V6 3.4	97-00	012/125
A2264-13C	MALIBU L4 2.4 V6 3.1	99-01	013/125
A2348-13C	BONNEVILLE / LASABRE V6 3.8	00-05	014/125
A2365-28N	CAMARO/FIRE BIRD V8.57	98-99	015/125
A2727-28P3	MALIBU/G6/AURA V6 3.5/3.9	04/10	016/125
A2728-13C	AZTEK/VENTURE/IMPALA V6 3.4/3.5	01-06	017/125
A2728-28C	AZTEK/VENTURE 3.4/IMPALA V6 3.4/3.5	03-05	018/125
A2864-28C	MALIBU/G6/AURA L4 2.4/V6 3.6	08-12/06-10 07-09	019/126
A2879-28C	EQUINOX / TORRENT V6 3.4	06-09	020/126
A2881-28C	MONTANA / UPLANDER/TERRAZA V6 3.9	06-08	021/126
A2969-13C	SOLSTICE/SKY/SUBURBAN JIMMYC/K SERIES L4 2.0/2.4	06-09/07-10 04-06	022/126
A13050-28C	SOLSTICE/SKY L4 2.0/2.4	06-09/07-10	023/126
A13097-28C	AVEO / G3 5 L4 1.6	09-11/09	024/126
A13097-28N	AVEO / G3 /SWIFT L4 1.6	09-11/09	025/126
0333	BERETTA/CORSICA/TEMPEST L4 2.0/ V6 2.8	87-91	026/126
0951	CAMARO/P SERIES 26 A L4 2.5 V6 3.1/3.8 V8 5.0/5.7	82-92/89-90	027/126
1206	LUMINA/CUTLASS SUPREME V6 3.1	91-93	028/127
1344	BERETTA/CORSICA L4 2.2/2.3 V6 3.1	92-94	029/127
1476	TRANS SPORT/LUMINA APV V6 3.8	92-95	030/127
1486	CAMARO/TRANS AM V8 5.7	93-02	031/127
1519	LUMINA/CUTLASS/GRAND PRIX V6 3.1/3.4/3.8	94-01	032/127
2251	LUMINA/MONTECARLO V6 3.1/3.4/3.8	96-01	033/127
2562	AZTEK/VENTURE/UPLANDER V6 3.4/3.5	01-05	034/127
2710	MONTECARLO/IMPALA/LA CROSSE V6 3.4/3.8	04-09	035/127
2727	G6/ MALIBU V6 3.5/3.9	05/04-09	036/127
2774	AVEO 5/ G3 / SWIFT L4 1.6	04-08	037/128
2864	MALIBU/G6/AURA L4 2.4 / V6 3.6	08-12/07-09	038/128
2873	AVEO/AVEO 5/G3 L4 1.6	04-08	039/128
2972	MALIBU/ G6 V6 3.5/3.9	2007	040/128
13049	COROLLA/MATRIX/VIBE L4 2.4	09-13	041/128
PORSCHE			
A2756-44N	Q7/CAYENNE/TOUAREG V6 3.0/3.2/3.6 V8 4.1/4.2/4.5/4.8 V10 4.9/5.0	03/15	042/128
LHRP429	CAYENNE/TOUREG/Q7 V6 3.0/3.2/3.6 V8 4.2/4.5/4.8 V10 4.9/5.0	03-10/07-13	043/128
LHRP593	BOXTER/911 H6 2.7/3.2/3.4/3.6	00-06/99-04	044/128

CODIGO	APLICACION	AÑOS	DIBUJO /PAGINA
RENAULT			
A024-28N	MEGANE L4 1.5/1.6/1.9/2.0		001/130
A6207-28N	CLIO/PLATINA L4 1.4/1.6 16V.	02-04	002/130
LHRP110-16MT	MEGANE/CLIO/SCENIC II L4 1.6	02-06	003/130
LHRP269-2	KANGOO L4 1.5/1.9	00-03	004/130
LHRP293	MEGANE/SCENIC L4 1.6	02-06	005/130
RT0040-24M	MEGANE L4 1.6/2.0 ALUMINIO MECÁNICO	06-09	006/130
SATURN			
A2191-13C	Sc1 / SL BASE / L4 1.9	94-02	007/130
A2727-28P3	MALIBU/G6/AURA V6 3.5/3.9	04/10	008/130
A2864-28C	MALIBU/G6/AURA L4 2.4/V6 3.6	08-12/06-10 07-09	009/130
A2969-13C	SUBURBAN JIMMY/C/K SERIES L4 2.0/2.4	94-00	010/131
A13007-28C	ENCLAVE / TRAVERSE V6 3.8	08-13/09/12	011/131
A13050-28C	SKY/SOLSTICE L4 2.0	07-10/07-09	012/131
A13057-28C	CAPTIVA/VUE L4 2.4 / V6 3.0/3.5/3.6	08-16/08-10	013/131
2191	S-SERIES L4 1.9	94-02	014/131
2608	ION 1-2-3 L4 2.0/2.2/2.4	03-04	015/131
2727	G6/MALIBU V6 3.5/3.9	05/04-09	016/131
13057	CAPTIVA SPORT/VUE L4 2.4 / V6 3.0/3.5/3.6	08-15	017/131
SCION			
A2889-13N	YARIS / XD 1.5	06-12/08-11	018/131
A2890-13C	YARIS / XD L4 1.5/1.8	06-12/08-11	019/132
SEAT			
A020-28N	A3/LEON/TOLEDO/GOLF L4 1.4/1.9/2.0	2005	001/134
A025-28N	IBIZA / A1 / POLO / VENTO L4 1.6/1.8/1.9	02-10/11-12 13-14/14-15	002/134
A045-28N	IBIZA / CORDOBA L4 1.6/1.4/2.0	03-07	003/134
M045-26N	IBIZA/CORDOBA 1.4/1.6/2.0 L4	03-07	004/134
ST0010-24M	IBIZA/CORDOBA L4 1.8/2.0 ALUMINIO MECÁNICO	99-04	005/134
SUBARU			
A2777-13C	FORESTER/OUTBACK/LEGACY/IMPRESA H4 2.0/2.5	05-09/08-13	006/134
2450	IMPRESA H4 2.0	02-03	007/134
SUZUKI			
2703	IMPRESA/ BAJA H4 2.0/2.5	03-07	008/134
2778	LEGACY/IMPRESA H4 2.5	05-08	009/134
A2087-28C	TRACKER/GRAND VITARA L4 1.6/1.8/2.0 V6 2.5/2.7	96-97/99-00	010/135
A2788-13C	RENO/FORENZA/OPTRA L4 1.6/1.8/2.0 V6 2.5/2.7	04-08/04-07	011/135
A2920-13C	GRAND VITARA I4 2.4 v6 2.7/3.2	06-12	012/135
A13097-28N	AVEO / G3/SWIFT L4 1.6	09-11/09	013/135
1444	SIDEKICK/TRACKER/SWIFT L4 1.0/1.4/1.6	88-94	014/135
1864	TRACKER/SIDEKICK L4 1.6	92-98	015/135
2088	SIDEKICK/TRACKER M/T L4 1.6	96-97/96-98	016/135
2089	TRACKER X-90 L4 1.6	94-98	017/135
2451	AERIO L4 2.0/2.3	00-07	018/135
2774	AVEO 5/ G3 / SWIFT L4 1.6	04-08	019/136
2788	OPTRA/RENO/FORENZA L4 2.0	04-07	020/136
2873	AVEO/AVEO 5/G3 L4 1.6	04-08	021/136
2980	Sx4 L4 2.0	2007	022/136
13136	GRAND VITARA L4 2.4	09-15	023/136
TOYOTA			
A012-44P7	MONTACARGAS L4 2.2 Gasolina L6 4.3 Gas Lp, Diesel	90-11	001/138
A0945-28C	SERIES PICK UP/RUNNER L4 2.4	85-95/92-95	002/138
A2428-28C	COROLLA/VIBE L4 1.8	03-08	003/138
A2432-28N	COROLLA/VIBE L4 1.8	03-08	004/138
A2580-28C	4 RUNNER/ FJ CRUSIER V6 4.0	03-09/07-12	005/138
A2581-28C	4 RUNNER / Gx470 V6 4.7	03-09	006/138
A2681-13C	SIENNA V6 3.3	04-06	007/138
A2817-13C	CAMRY/AVALON L4 2.4 V6 3.5	05-11	008/138
A2889-13N	YARIS / XD 1.5	06-12/08-11	009/138
A2890-13C	YARIS / XD L4 1.5/1.8	06-12/08-11	010/139
A2893-28C	RAV4 L4 2.5 V6 3.5	06-12	011/139
A2917-13C	CAMRY L4 2.4/2.5	07-11	012/139
A8042-44P7	MONTACARGAS L4 2.2 L6 4.3	90-11	013/139
A8043-44P7	MONTACARGAS	07-11	014/139
A13035-13C	CAMRY / ES350 L4 2.4 / V6 3.5	07-11/07-12	015/139
A13076-13C	SIENNA V6 3.5	07-10	016/139
A13116-13C	SIENNA L4 2.7 V6 3.5	90-11	017/139
0021	CAMRY V6 2.5	87-91	018/139
0050	PICK UP/4 RUNNER V6 3.0	88-95	019/140
0537	COROLLA/PRIZM L4 1.6	88-92	020/140
0539	COROLLA L4 1.6	88-92	021/140
0945	4 RUNNER/PICK UP L4 2.4	84-91/86-95	022/140
1318	CAMRY L4 2.2	92-96	023/140

CODIGO	APLICACION	AÑOS	DIBUJO /PAGINA
TOYOTA			
1319	TERCEL/PASEO L4 1.5	91-95	024/140
1409	COROLLA L4 1.6/1.8	93-97	025/140
1428	CAMRY L4 2.2	92-96	026/140
1512	T-100 L4 2.7 V6 3.0/3.4	93-98	027/140
1575	CELICA L4 2.2	94-99	028/141
1746	CAMRY/ES300/AVALON V6 3.0	94-99	029/141
1750	TERCEL/PASEO L4 1.5	95-99	030/141
1755	TACOMA L4 2.7 V6 3.7	95-04	031/141
1774	TACOMA L4 2.4/2.7 V6 3.4	95-04	032/141
1778	TACOMA L4 2.4/2.7 V6 3.4	95-04	033/141
1859	RAV4 L4 2.0	96-98	034/141
1917	LAND CRUISER L6 4.5	93-97	035/141
1918	LAND CRUISER L6 4.5	95-98	036/141
1998	4 RUNNER L4 2.7 V6 3.4	96-02	037/142
2004	CAMRY (26 MT) V6 3.0	97-01	038/142
2090	T-100 L4 2.7 V6 3.0/3.4	93-98	039/142
2198	COROLLA/PRIZM L4 1.8	98-02	040/142
2292	RAV-4 L4 2.0	98-00	041/142
2304	ECHO L4 1.5	00-05	042/142
2305	YARIS 1300/ECHO L4 1.5	00-05	043/142
2320	TUNDRA V6 3.4/4.0	00-06	044/142
2321	TUNDRA V8 4.7	00-06	045/142
2322	TUNDRA V6 3.4	00-04	046/143
2403	RAV-4 L4 2.0/2.4	01-05	047/143
2411	RAV4 L4 2.0	01-03	048/143
2427	SIENNA V6 3.0	01-03	049/143
2434	CAMRY/ES330/SOLARA V6 3.0/3.3	02-08	050/143
2435	CAMRY/ES300 V6 3.0/3.3	02-06	051/143
2436	CAMRY/SOLARA L4 2.4	02-08	052/143
2437	CAMRY L4 2.4	02-06	053/143
2802	TACOMA L4 2.7 V6 4.0	05-13	054/143
2891	RAV4 L4 2.4/2.5	06-11	055/144
2892	RAV4 L4 2.4/2.5 V6 3.5	06-08	056/144
2919	ES350/VENZA V6 3.5	07-09	057/144
2992	TUNDRA V6 4.0 V8 4.7	2007	058/144
2994	SEQUOIA/TUNDRA V8 4.6/5.7	07-14	059/144
13049	COROLLA/MATRIX/VIBE L4 2.4	09-13	060/144
13076	SIENNA V6 3.5	07-10	061/144
13106	COROLLA/MATRIX L4 1.8	09-14	062/144
13117	SIENNA V6 3.5	11-15	063/144
13319	PRIUS C L4 1.5	12-16	064/145
LHRP189-26AT	HILUX L4 2.7	05-08	065/145
LHRP234	HILUX L4 2.5	2004	066/145
LHRP373	HILUX L4 2.5	2004	067/145
LHRP515	HILUX L4 2.5	2004	068/145
LHRP710-2	AVANZA L4 1.5	08-12	069/145
VOLKSWAGEN			
A020-28N	A3/LEON/TOLEDO/GOLF L4 1.4/1.9/2.0	2005	001/148
A025-28N	A1 / IBIZA / POLO / VENTO L4 1.6/1.8/1.9	11-12/02-10 13-14/14-15	002/148
A0837-28N	JETTA/GOLF L4 1.6/1.7/1.8/2.0	80-92	003/148
A1557-28N	GOLF/CABRIO/JETTA L4 1.8/1.9/2.0	93-98/95-02	004/148
A2241-28N	BETLE L4 1.8/1.9/2.0 L5 2.5	98-06	005/148
A2265-28N	JETTA/GOLF/PASSAT L4 1.8/1.9/2.0 V6 2.8/3.2	98-11	006/148
A2756-44N	Q7/CAYENNE/TOUAREG V6 3.0/3.2/3.6 V8 4.1/4.2/4.5/4.8 V10 4.9/5.0	03/15	007/148
A2822-28N	JETTA/GOLF/EOS L4 2.0	06-13	008/148
A6040-28N	POINTER L4 1.8/2.0	98-08	009/148
A6040-44N	POINTER L4 1.8/2.0	98-08	010/149
1557	GOLF/GTI/JETTA/CABRIO L4 1.8/1.9/2.0	92-02	011/149
2648	PASSAT/QUATTRO/A6 V6 2.7/2.8	98-04	012/149
2872	TOUAREG V10 5.0	05-08	013/149
2995	JETTA/GOLF L4 2.0 L5 2.5 V6 3.2	05-13	014/149
13212	PASSAT/JETTA/BETLE EOS/TT/QUATRO L4 1.4/1.8/2.0	09-15	015/149
13215	JETTA BICENTENARIO/GOLF/BETLE L4 2.0/L5 2.5	11-15	016/149
M1557-26N	JETTA/GOLF/CABRIO/CABRIOLET L4 1.8/1.9/2.0	83-85/83-88	017/149
M2265-26N	JETTA/GOLF/TT/QUATRO L4 1.8/1.9/2.0 V6 2.8	00-10	018/149
M13272-26N	TIGUAN L4 1.4/2.0	10-15	019/150
LHRP487-2	LUPO/POLO/GOL/CROSS FOX 1.2/1.4	05-12	020/150
LHRP488-1	GOL/LUPO/CROSS FOX L4 1.4/1.6/1.8/1.9	05-09	021/150
LHRP596	TIGUAN L4 1.4/2.0	07-14	022/150
1557-26N	GOLF/JETTA/CABRIO/CABRIOLET L4 1.8/1.9/2.0 AM	92-02/95-02	023/150
1557-32M	GOLF/JETTA L4 1.8/1.9/2.0 ALUMINIO MECÁNICO	93-99	024/150

GUÍA POR CÓDIGO
VER PÁG. 165

CODIGO	APLICACION	AÑOS	DIBUJO /PAGINA
VOLKSWAGEN			
2265-24M	GOLF/JETTA L4 1.8/1.9/2.0 V6 2.8 ALUMINIO MECÁNICO	99-05	025/150
VOLVO			
2400	S40/V40 L4 1.9	99-04	026/150
2805	S60/S80/V70 L5 2.4/2.5 L6 2.8/2.9	99-06/99-09	027/150
2878	XC90/XC60 L5 2.5 L6 2.9/3.2 V8 4.4	03-13	028/151
13315	S60/S80/V60/V70/XC60/XC70 L4 2.0/2.5 / L6 3.0/3.2 / V8 4.4	08-15	029/151
ATE8075-44P5	CNX VISION/VN SERIES AUT 800040, VOL40, 239311, 80040WF, 2001-4605		030/151
TRACTOCAMIÓN ALUMINIO-PLÁSTICO			152
POST-ENFRIADORES			157



CODIGO	APLICACION	AÑOS	DIBUJO /PAGINA
--------	------------	------	----------------

Radiadores

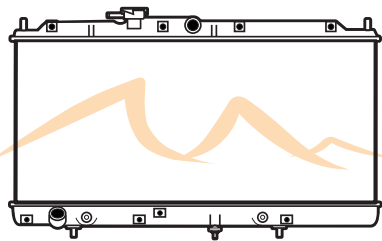
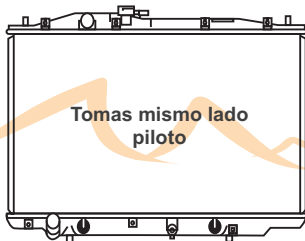
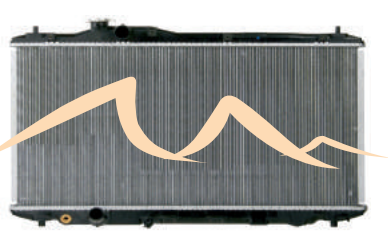
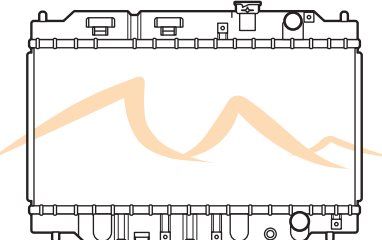
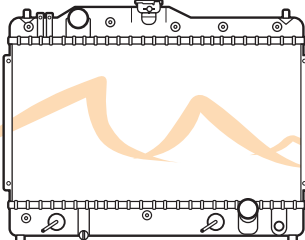
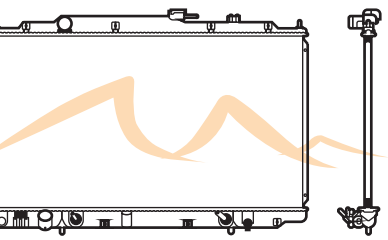
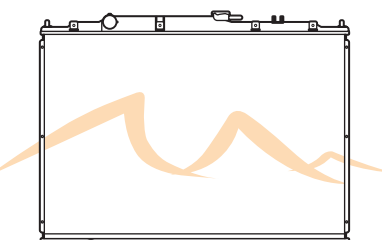
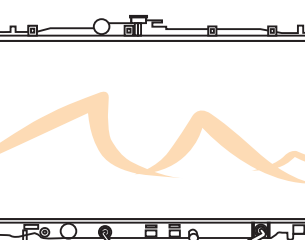
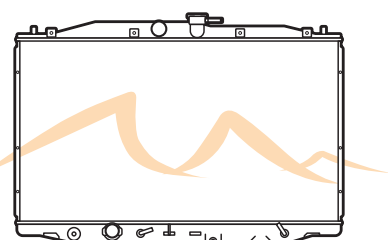

PHAR

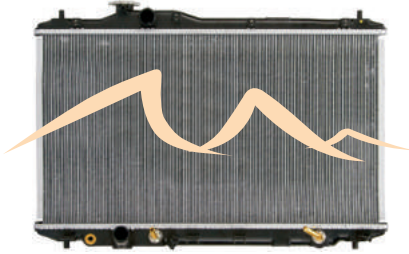
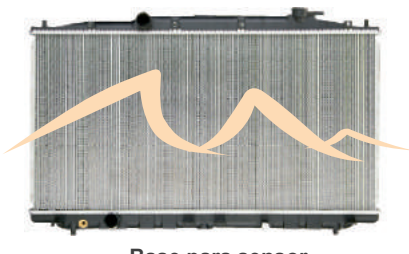
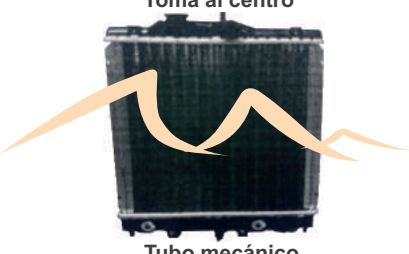
- **ACURA**
- **AUDI**
- **BMW**

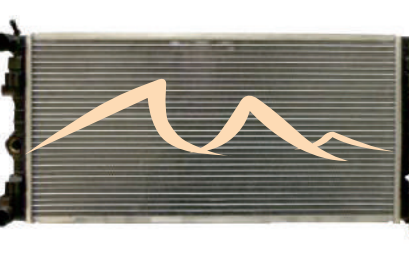
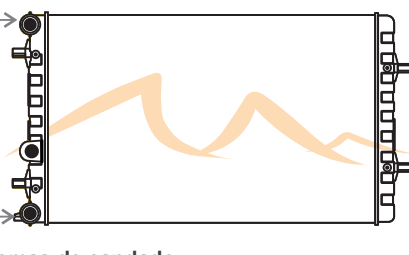
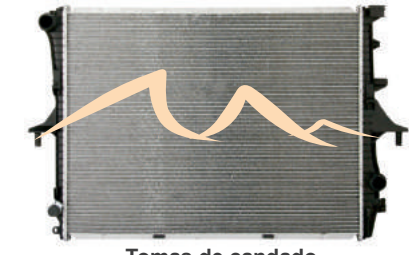
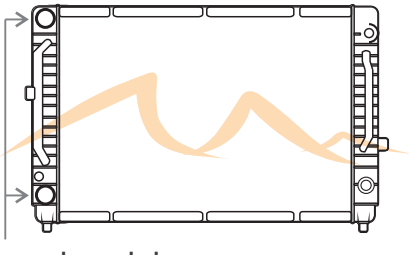
<p>A1776-28C ACURA / HONDA</p>  <p>ACCORD/ACURA CL 95-97/97-99</p> <p>DPI 1776 V6 2.7/3.0</p> <p>PANAL: 14 13/16" X 27 3/4" X 1 1/8" (26 mm) CAB. SUP.: 1 3/8" X 26 3/4" CAB. INF.: 1 5/8" X 26 3/4" ENF. TRANS.: SI ENF. MOTOR: NO</p> <p>TOMAS: ENTRADA: 1 1/4" SALIDA: 1 1/4"</p> <p>001</p>	<p>A2773-28N ACURA</p>  <p>Tomas mismo lado piloto</p> <p>ACURA TL 04-08</p> <p>DPI 2773 V6 3.2/3.5</p> <p>PANAL: 16 5/8" X 28" X 1 1/8" CAB. SUP.: 1 7/8" X 28 5/16" CAB. INF.: 1 7/8" X 28 15/16" ENF. TRANS.: NO ENF. MOTOR: NO</p> <p>TOMAS: ENTRADA: 1 1/4" SALIDA: 1 1/4"</p> <p>002</p>	<p>A13221-13N HONDA/ACURA</p>  <p>Toma inferior</p> <p>CIVIC 12-15 / ILX 13-15</p> <p>DPI 13221 L4 1.8/2.4</p> <p>PANAL: 14 3/4" X 26 3/8" X 1/2" CAB. SUP.: 1 5/16" X 27" CAB. INF.: 1 15/16" X 27" ENF. TRANS.: NO ENF. MOTOR: NO</p> <p>TOMAS: ENTRADA: 1 1/4" SALIDA: 1 1/4"</p> <p>003</p>
<p>1568 DPI ACURA</p>  <p>INTEGRA 94-01</p> <p>M/T L4 1.8</p> <p>PANAL: 13 3/4" X 26" X 5/8" (16 mm) CAB. SUP.: 1 3/4" X 26 5/8" CAB. INF.: 2 1/8" X 27 1/4" ENF. TRANS.: 12 3/4" ENF. MOTOR: NO</p> <p>TOMAS: ENTRADA: 1 1/4" SALIDA: 1 1/4"</p> <p>004</p>	<p>1912 DPI ACURA</p>  <p>RL 96-04</p> <p>V6 3.5</p> <p>PANAL: 17 3/4" X 26 3/4" X 5/8" (16 mm) CAB. SUP.: 1 3/8" X 27 1/2" CAB. INF.: 1 7/8" X 27 1/2" ENF. TRANS.: 14 3/4" ENF. MOTOR: NO</p> <p>TOMAS: ENTRADA: 1 1/4" SALIDA: 1 1/4"</p> <p>005</p>	<p>2417 DPI ACURA / HONDA</p>  <p>PILOT/MDX 03-04</p> <p>V6 3.5</p> <p>PANAL: 19 11/16" X 31 1/8" X 5/8" (16 mm) CAB. SUP.: 1 3/8" X 31 1/4" CAB. INF.: 1 3/8" X 31 1/4" ENF. TRANS.: 14 3/4" ENF. MOTOR: NO</p> <p>TOMAS: ENTRADA: 1 1/2" SALIDA: 1 1/2"</p> <p>CONDENSADOR: AC3182</p> <p>006</p>
<p>2740 DPI ACURA / HONDA</p>  <p>MDX/PILOT 03-06/2005</p> <p>V6 3.5</p> <p>PANAL: 19 11/16" X 19" X 1 5/8" CAB. SUP.: 1 7/8" X 31 1/4" CAB. INF.: 1 7/8" X 31 1/4" ENF. TRANS.: 14 3/4" ENF. MOTOR: NO</p> <p>TOMAS: ENTRADA: 1 1/4" SALIDA: 1 1/4"</p> <p>CONDENSADOR: AC3182</p> <p>007</p>	<p>2916 DPI ACURA</p>  <p>Toma inferior de candado</p> <p>RDX 07-12</p> <p>L4 2.3</p> <p>PANAL: 16 1/2" X 30" X 1" (26 mm) CAB. SUP.: 1 7/8" X 31 5/16" CAB. INF.: 1 7/8" X 31 5/16" ENF. TRANS.: SI Concéntrico ENF. MOTOR: NO</p> <p>TOMAS: ENTRADA: 1 1/4" SALIDA: 1 1/4"</p> <p>008</p>	<p>2966 DPI ACURA</p>  <p>Toma de candado</p> <p>TSX 06-08</p> <p>L4 2.4</p> <p>PANAL: 15 3/4" X 28 1/4" X 5/8" (16 mm) CAB. SUP.: 1 5/16" X 29" CAB. INF.: 1 7/8" X 29" ENF. TRANS.: SI ENF. MOTOR: NO</p> <p>TOMAS: ENTRADA: 1 1/4" SALIDA: 1 1/4"</p> <p>009</p>

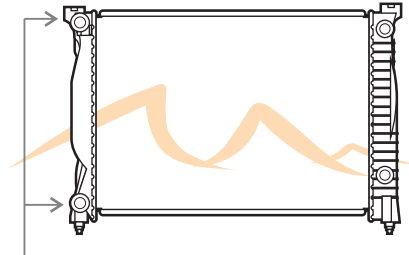
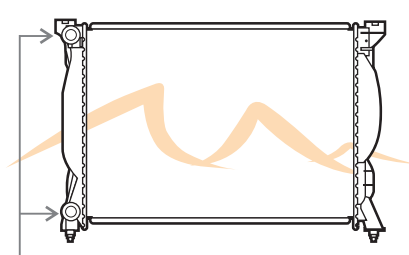
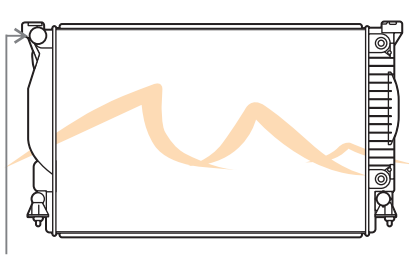
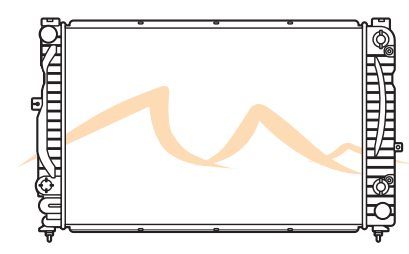
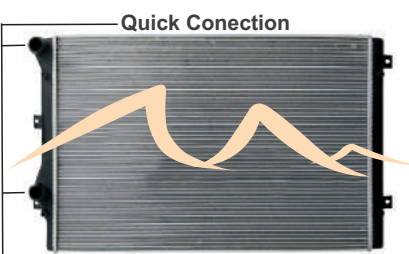
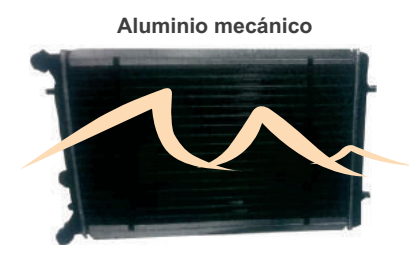
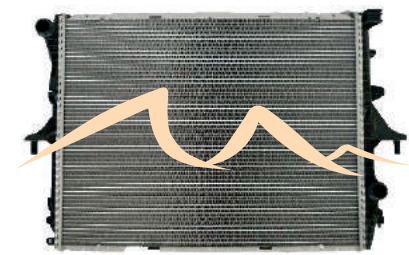
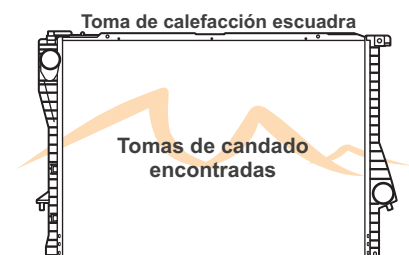
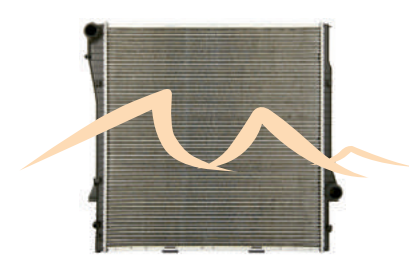
<p>13257 DPI HONDA/ACURA</p>  <p>CIVIC/ILX 12-15 L4 1.5/1.8</p> <p>PANAL: 14 3/4" X 26 7/16" X 11/16" CAB. SUP.: 1 7/16" X 27 7/16" CAB. INF.: 1 7/16" X 27 7/16" EDA: SI CONCENTRICO</p> <p>TOMAS: ENTRADA: 1 1/4" SALIDA: 1 1/4"</p> <p>CONDENSADOR: AC3976</p> <p>010</p>	<p>13421 DPI ACURA</p>  <p>RLX 14-16 V6 3.5</p> <p>PANAL: 15 3/4" X 30 1/8" X 1" CAB. SUP.: 1 7/8" X 31 1/4" CAB. INF.: 1 7/8" X 31 1/4" ENF. TRANS.: NO ENF. MOTOR: NO</p> <p>TOMAS: ENTRADA: 1 1/4" SALIDA: 1 1/4"</p> <p>011</p>	<p>M2274-26C ACURA/HONDA</p>  <p>Toma al centro</p> <p>CIVIC 92-00 / EL 97-00 L4 1.5/1.6</p> <p>DPI 1290 / 6206 PHAR</p> <p>PANAL: 13 3/4" X 13 3/8" X 1" CAB. SUP.: 1 7/8" X 14 9/16" CAB. INF.: 1 7/8" X 14 9/16" ENF. TRANS.: SI ENF. MOTOR: NO</p> <p>TOMAS: ENTRADA: 1 1/8" SALIDA: 1 1/8"</p> <p>012</p>
<p>M2274-26N ACURA/HONDA</p>  <p>Toma al centro</p> <p>CIVIC 92-00 / EL 97-00 L4 1.5/1.6</p> <p>DPI 1290 / 6206 PHAR</p> <p>PANAL: 13 3/4" X 13 3/8" X 1" CAB. SUP.: 1 7/8" X 14 9/16" CAB. INF.: 1 7/8" X 14 9/16" ENF. TRANS.: NO ENF. MOTOR: NO</p> <p>TOMAS: ENTRADA: 1 1/8" SALIDA: 1 1/8"</p> <p>013</p>	<p>A020-28N AUDI/SEAT/VW</p>  <p>Toma de candado lado piloto</p> <p>A3/LEON/TOLEDO/GOLF 05 L4 1.4/1.9/2.0</p> <p>PANAL: 25 1/2" X 15 5/8" X 1 1/8" CAB. SUP.: 1 11/16" X 16 3/8" CAB. INF.: 1 11/16" X 16 3/8" ENF. TRANS.: NO ENF. MOTOR: NO</p> <p>TOMAS: ENTRADA: 1 5/16" SALIDA: 1 5/16"</p> <p>014</p>	<p>A025-28N SEAT/AUDI/VW</p>  <p>IBIZA 02-10/A1 11-12/POLO 13-14/VENTO 14-15 L4 1.8/1.9/1.6</p> <p>PANAL: 25 1/2" X 12 3/8" X 1 1/8" CS: 1 15/16" X 13 3/8" CI: 1 15/16" X 13 3/8"</p> <p>ENTRADA: 1 1/4" SALIDA: 1 1/4"</p> <p>ENFRIADOR: NO</p> <p>015</p>
<p>A2265-28N AUDI/VOLKSWAGEN</p>  <p>Tomas de candado</p> <p>TT7QUATTRO/GOLF/JETTA 98-10 DPI 2265 L4 1.8/1.9/2.0 V6 2.8/3.2</p> <p>PANAL: 25 5/16" X 16 1/2" X 1 1/8" (28 mm) CAB. SUP.: 1 5/8" X 16 5/16" CAB. INF.: 1 5/8" X 16 5/16" ENF. TRANS.: NO ENF. MOTOR: NO</p> <p>TOMAS: ENTRADA: 1 1/4" SALIDA: 1 1/4"</p> <p>016</p>	<p>A2756-44N AUDI/PORSCHE/VW</p>  <p>Tomas de candado</p> <p>Q7 06-15/CAYENNE 03-10/TOUAREG 04-10 V6 3.0/3.2/3.6 / V8 4.1/4.2/4.5/4.8 / V10 4.9/5.0</p> <p>PANAL: 28" X 21 1/4" X 1 3/4" CAB. SUP.: 2 3/8" X 22 7/8" CAB. INF.: 2 3/8" X 22 7/8" ENF. TRANS.: NO</p> <p>TOMAS: ENTRADA: 1 1/2" SALIDA: 1 1/2"</p> <p>CONDENSADOR: AC3294</p> <p>017</p>	<p>2034 DPI AUDI</p>  <p>Tomas de candado</p> <p>A4/PASSAT/S4 96-04 L4 1.8 V6 2.8</p> <p>PANAL: 24 7/8" X 16 3/8" X 7/8" (22 mm) CAB. SUP.: 2" X 16 5/16" CAB. INF.: 1 9/16" X 16 9/16" ENF. TRANS.: 11 13/16"</p> <p>TOMAS: ENTRADA: 1 1/4" SALIDA: 1 1/4"</p> <p>ENF. MOTOR: NO</p> <p>018</p>

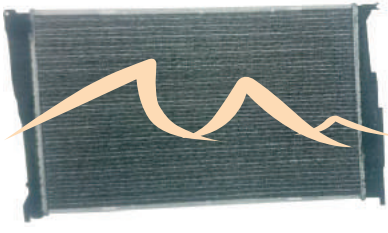
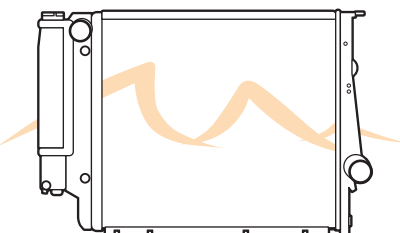
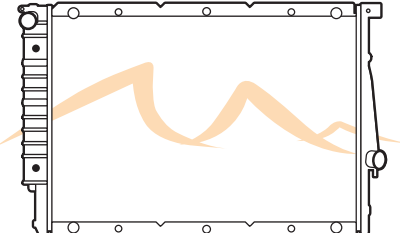
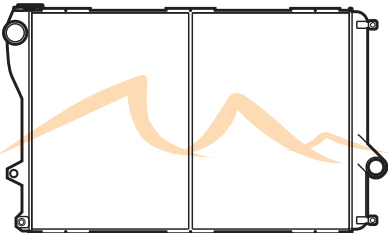
<p>2556 DPI AUDI</p>  <p>Tomas de candado</p> <p>A4/A4 QUATTRO 03-06 L4 1.8/2.0</p> <p>PANAL: 24 7/8" X 16" X 1" (26 mm) CAB. SUP.: 1 7/8" X 16 1/2" CAB. INF.: 1 11/16" X 16 1/2" ENF. TRANS.: 11 3/4" ENF. MOTOR: NO</p> <p>TOMAS: ENTRADA: 1 1/4" SALIDA: 1 1/4"</p> <p>019</p>	<p>2557 DPI AUDI</p>  <p>Tomas de candado</p> <p>A4/A4 QUATTRO 02-06 M/T L4 1.8/2.0</p> <p>PANAL: 24 7/8" X 16" X 1" (26 mm) CAB. SUP.: 1 11/16" X 16 1/2" CAB. INF.: 1 11/16" X 16 1/2" ENF. TRANS.: NO ENF. MOTOR: NO</p> <p>TOMAS: ENTRADA: 1 1/4" SALIDA: 1 1/4"</p> <p>020</p>	<p>2590 DPI AUDI</p>  <p>Tomas de candado</p> <p>A4/A4 QUATTRO 02-11 V6 3.0/3.2</p> <p>PANAL: 24 7/8" X 17 1/2" X 1 3/8" CAB. SUP.: 1 7/8" X 18 1/16" CAB. INF.: 1 7/8" X 18 1/16" ENF. TRANS.: 13 1/4" ENF. MOTOR: NO</p> <p>TOMAS: ENTRADA: 1 3/16" SALIDA: 1 3/16"</p> <p>021</p>
<p>2648 DPI AUDI / VOLKSWAGEN</p>  <p>QUATTRO/PASSAT/A6 98-04 V6 2.7/2.8</p> <p>PANAL: 24 7/8" X 15 11/16" X 1 3/16" CAB. SUP.: 1 9/16" X 16 9/16" CAB. INF.: 1 9/16" X 16 9/16" ENF. TRANS.: 11 3/4" Concéntrico ENF. MOTOR: NO</p> <p>TOMAS: ENTRADA: 1 3/8" SALIDA: 1 3/8"</p> <p>022</p>	<p>13212 DPI AUDI/VOLKSWAGEN</p>  <p>Quick Connection</p> <p>Tomas mismo lado piloto</p> <p>PASSAT/JETTA/BEETLE EOS/TT/QUATRO 09-15 L4 1.4/1.8/2.0</p> <p>PANAL: 25 5/8" X 17 1/2" X 1 1/4" (32mm) CAB. SUP.: 1 13/16" X 17 7/8" CAB. INF.: 1 13/16" X 17 7/8" ENF. TRANS.: NO ENF. MOTOR: NO</p> <p>TOMAS: ENTRADA: 1 1/4" SALIDA: 1 1/4"</p> <p>CONDENSADOR: AC3255/AC3493</p> <p>023</p>	<p>M2265-26N AUDI/VOLKSWAGEN</p>  <p>Aluminio mecánico</p> <p>Tomas de candado Tomas mismo lado piloto</p> <p>JETTA/GOLF 00-10/TT/QUATRO 00-06 L4 1.8/1.9/2.0 / V6 1.4/2.8/3.2</p> <p>PANAL: 25 1/2" X 14 15/16" X 1" CAB. SUP.: 16 15/16" X 1 5/8" CAB. INF.: 16 15/16" X 1 5/8" ENF. TRANS.: NO</p> <p>TOMAS: ENTRADA: 1 1/4" SALIDA: 1 1/4"</p> <p>024</p>
<p>LHRP429 AUDI/VOLKSWAGEN/PORSCHE</p>  <p>Q7 07-13/TOUREG 04-10/CAYENNE 03-10 V6 3.0/3.2/3.6 V8 4.2/4.5/4.8 V10 4.9/5.0</p> <p>PANAL: 27 15/16" X 21 9/16" X 1 11/16" CAB. SUP.: 2 7/16" X 22 7/8" CAB. INF.: 2 7/16" X 22 7/8" ENF. TRANS.: NO ENF. MOTOR: NO</p> <p>TOMAS: ENTRADA: 1 1/2" SALIDA: 1 1/2"</p> <p>025</p>	<p>A2284-44N BMW</p>  <p>Toma de calefacción esquadra</p> <p>Tomas de candado encontradas</p> <p>740i/750L 99-01 525i/528i/530i/545i 98-05 DPI 2284 L6 2.5/2.8/3.0 V8 4.4 V12 5.4</p> <p>PANAL: 25 1/2" X 17 1/8" X 1 3/4" CAB. SUP.: 2 3/8" X 18" CAB. INF.: 2 3/8" X 18" ENF. TRANS.: NO ENF. MOTOR: NO</p> <p>TOMAS: ENTRADA: 1 1/2" SALIDA: 1 1/2"</p> <p>026</p>	<p>A2593-28N BMW</p>  <p>Tomas de candado</p> <p>X5 00-06 V8 4.4/4.6/4.8</p> <p>PANAL: 23 1/4" X 23 1/4" X 1 1/8" CAB. SUP.: 2 3/16" X 24 5/8" CAB. INF.: 2 3/16" X 24 5/8" ENF. TRANS.: NO</p> <p>TOMAS: ENTRADA: 1 1/2" SALIDA: 1 1/2"</p> <p>027</p>

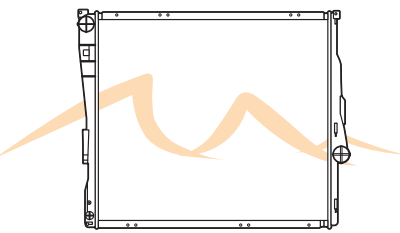
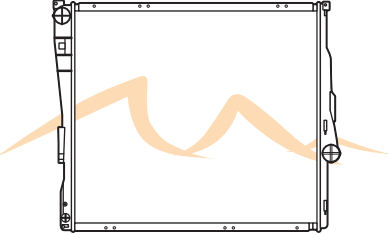
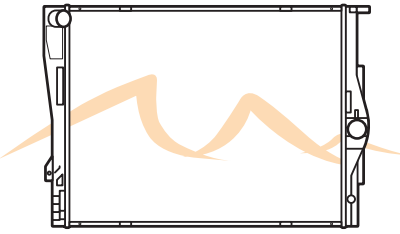
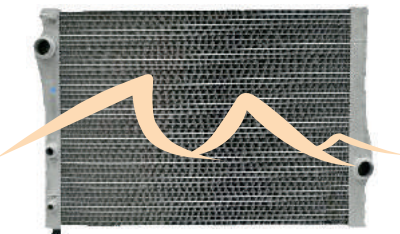
<p>A2973-28N BMW</p>  <p>Tomas de candado</p> <p>335i 07/11 L6 3.0</p> <p>PANAL: 23 3/4" X 13 1/4" X 1 1/8" CAB. SUP.: 14 5/16" X 1 7/8" CAB. INF.: 14 5/16" X 1 7/8" ENF. TRANS.: NO</p> <p>TOMAS: ENTRADA: 1.532 SALIDA: 1.532</p> <p>028</p>	<p>1295 DPI BMW</p>  <p>318 SERIES/Z3 ROADSTER 87-99/95-01 L4 1.8/1.9</p> <p>PANAL: 17 1/4" X 17 1/4" X 1 3/8" CAB. SUP.: 2 5/8" X 17 5/8" CAB. INF.: 2 5/8" X 17 5/8" ENF. TRANS.: NO ENF. MOTOR: NO</p> <p>TOMAS: ENTRADA: 1 9/16" SALIDA: 1 9/16"</p> <p>029</p>	<p>1841 DPI BMW</p>  <p>320i/323i/325/328/M3 96-07/95-99 L6 2.0/2.5/2.8/3.0/3.2</p> <p>PANAL: 21 3/8" X 17" X 1 1/4" (32 mm) CAB. SUP.: 2 1/16" X 17 3/4" CAB. INF.: 2 1/16" X 17 3/4" ENF. TRANS.: NO ENF. MOTOR: NO</p> <p>TOMAS: ENTRADA: 1 9/16" SALIDA: 1 9/16"</p> <p>030</p>
<p>2285 DPI BMW</p>  <p>Tomas de candado</p> <p>540i 97-03/740i 95-01 V8 4.4/5.0</p> <p>7032 PHAR</p> <p>PANAL: 25 9/16" X 17 1/2" X 1 5/8" CAB. SUP.: 2 5/8" X 17 3/4" CAB. INF.: 2 5/8" X 17 3/4" ENF. TRANS.: NO ENF. MOTOR: NO</p> <p>TOMAS: ENTRADA: 1 1/2" SALIDA: 1 1/2"</p> <p>031</p>	<p>2594 DPI BMW</p>  <p>Tomas de candado</p> <p>X5 01-06 L6 3.0</p> <p>PANAL: 23 1/4" X 24 1/2" X 1" CS: 2 1/2" X 17 5/8" CI: 2 1/2" X 17 5/8" EDA: NO EDAM: NO</p> <p>ENTRADA: 1 9/16" SALIDA: 1 9/16"</p> <p>Toma recuperador lado piloto inferior</p> <p>032</p>	<p>2635 DPI BMW</p>  <p>Tomas de candado</p> <p>SERIES 323, 325, 330 98-00/01-05 L6 2.5/2.8/3.0</p> <p>PANAL: 22 7/8" X 17 1/4" X 1 1/4" (32 mm) CAB. SUP.: 18 1/8" X 1 9/16" CAB. INF.: 18 1/8" X 1 9/16" ENF. TRANS.: NO ENF. MOTOR: NO</p> <p>TOMAS: ENTRADA: 1 1/2" SALIDA: 1 1/2"</p> <p>033</p>
<p>2636 DPI BMW</p>  <p>Tomas de candado</p> <p>SERIES 323, 325, 330, Z4 98-00/01-11 L6 2.0/2.5/3.0</p> <p>PANAL: 22 7/8" X 17 1/4" X 1 1/4" (32 mm) CAB. SUP.: 18 1/8" X 1 9/16" CAB. INF.: 18 1/8" X 1 9/16" ENF. TRANS.: NO ENF. MOTOR: NO</p> <p>TOMAS: ENTRADA: 1 1/2" SALIDA: 1 1/2"</p> <p>034</p>	<p>2882 DPI BMW</p>  <p>Tomas de candado</p> <p>SERIES 325, 328, 330 06-12 L4 2.0/ L6 2.5/3.0</p> <p>PANAL: 23 5/8" X 18" X 1 1/4" (32 mm) CAB. SUP.: 18 3/4" X 1 11/16" CAB. INF.: 18 3/4" X 1 11/16" ENF. TRANS.: NO ENF. MOTOR: NO</p> <p>TOMAS: ENTRADA: 1 1/2" SALIDA: 1 1/2"</p> <p>035</p>	<p>LHRP568 BMW</p>  <p>Todo de aluminio</p> <p>X6 10-13 L6 3.0 V8 4.4</p> <p>PANAL: 23 1/16" X 17 3/8" X 1 1/2" CAB. SUP.: 1 7/8" X 17 3/4" CAB. INF.: 1 7/8" X 17 3/4" ENF. TRANS.: NO ENF. MOTOR: NO</p> <p>TOMAS: ENTRADA: 1 1/2" SALIDA: 1 1/2"</p> <p>036</p>

LHRP583

BMW

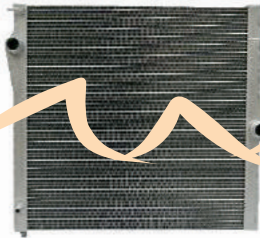

Todo de aluminio

X5 07-13

L6 3.0 V8 4.4

PANAL: 23 3/16" X 23 11/16" X 1 1/4"

CAB. SUP.: 1 1/2" X 23 15/16"

CAB. INF.: 1 1/2" X 23 15/16"

ENF. TRANS.: NO

ENF. MOTOR: NO

TOMAS:

ENTRADA: 1 1/2"

SALIDA: 1 1/2"

037



www.phar.com.mx

**PRUEBA NUESTRA
VERSION IMPRESA
EN LINEA**

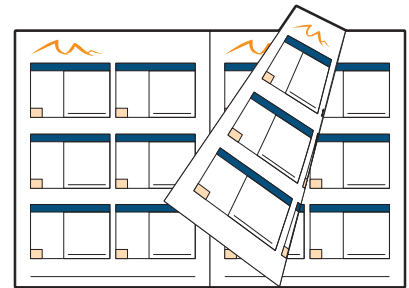

www.phar.com.mx

NOTAS

Radiadores

PHAR

- **BUICK**
- **CADILLAC**

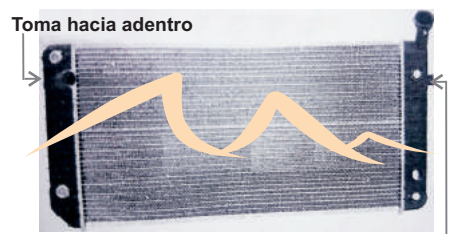
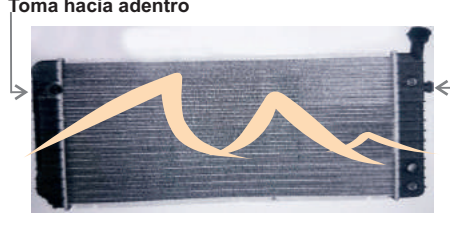
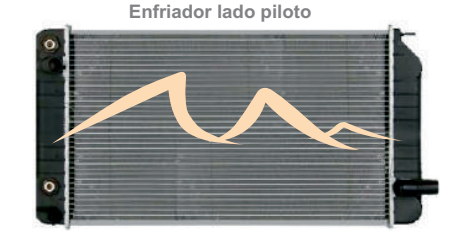
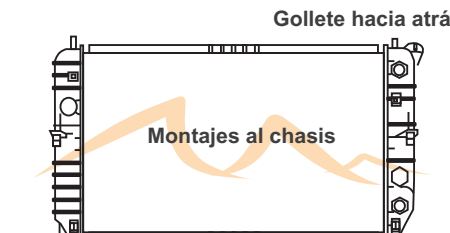
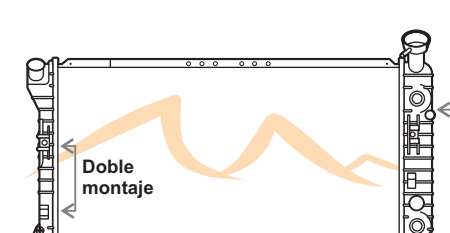
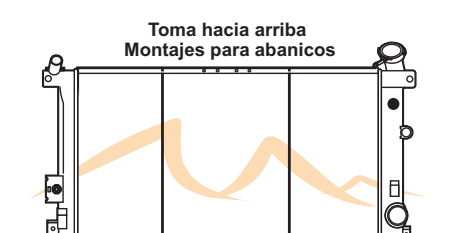
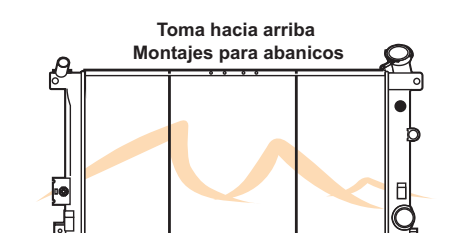
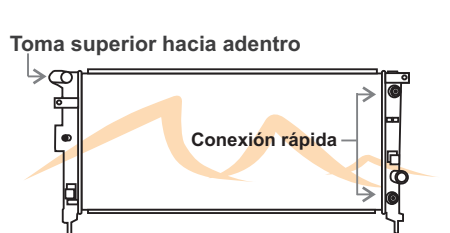
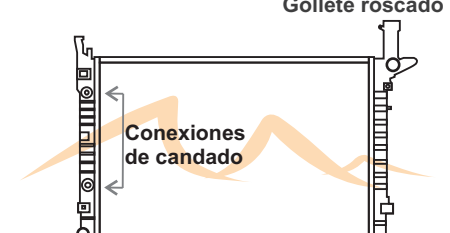
<p>A1051-28C BUICK/CHEVROLET PONTIAC/OLDSMOBILE</p>  <p>Toma hacia adentro</p> <p>Base hacia polvera</p> <p>REGAL CUSTOM 90-93/ LUMINA 91-93/ GRAND PRIX 91-93/CUTLASS 91-93</p> <p>DPI 1051 V6 3.1/3.4/3.8</p> <p>PANAL: 34 3/4" X 19 1/16" X 5" CAB. SUP.: 16 3/8" X 2 5/16" CAB. INF.: 16 3/8" X 2 5/16"</p> <p>TOMAS: ENTRADA: 1 5/16" SALIDA: 1 5/16"</p> <p>ENFRIADOR: SI DOBLE</p> <p>001</p>	<p>A1206-28C BUICK/CHEVROLET PONTIAC/OLDSMOBILE</p>  <p>Toma hacia adentro</p> <p>Base sensor</p> <p>REGAL CUSTOM 90-93/ LUMINA 91-93/ GRAND PRIX 91-93/CUTLASS SUPREME 92</p> <p>DPI 1206 / PHAR 6009 V6 3.1</p> <p>PANAL: 34 3/4" X 19 1/16" X 5" CAB. SUP.: 16 3/8" X 2 5/16" CAB. INF.: 16 3/8" X 2 5/16"</p> <p>TOMAS: ENTRADA: 1 5/16" SALIDA: 1 5/16"</p> <p>ENFRIADOR: SI</p> <p>002</p>	<p>A1344-28C BUICK/CHEVROLET OLDSMOBILE/PONTIAC</p>  <p>Enfriador lado piloto</p> <p>Toma curva hacia adentro 90°</p> <p>SKYLARK/BERETTA/CORSICA 92-93 ACHIEVA/GRAND AM 92-93</p> <p>DPI 1344 / PHAR 2276 L4 2.2/2.3 V6 3.1</p> <p>PANAL: 25 15/16" X 15 1/8" X 1 1/8" CS: 16 7/16" X 2 5/16" CI: 16 7/16" X 2 5/16"</p> <p>ENTRADA: 1 5/16" SALIDA: 1 5/16"</p> <p>ENFRIADOR: SI 75999-M</p> <p>03/15 003</p>
<p>A2348-13C BUICK/PONTIAC</p>  <p>Gollete hacia atrás</p> <p>Montajes al chasis</p> <p>BONNEVILLE 00-05/ LASABRE 00-05</p> <p>V6 3.8</p> <p>PANAL: 30 5/8" X 15 1/8" X 1/2" CAB. SUP.: 2 3/8" X 17 7/16" CAB. INF.: 2 3/8" X 17 7/16"</p> <p>ENF. TRANS.: SI ENF. MOTOR: NO</p> <p>TOMAS: ENTRADA: 1 5/16" SALIDA: 1 9/16"</p> <p>004</p>	<p>A2351-28P4 BUICK/CHEVROLET/GMC</p>  <p>Doble montaje</p> <p>Base sensor</p> <p>REGAL 00-04/IMPALA 00-02</p> <p>6219 PHAR V6 3.8</p> <p>PANAL: 30 1/2" X 15 5/16" X 1 1/8" CAB. SUP.: 2 7/16" X 16 9/16" CAB. INF.: 2 7/16" X 16 9/16"</p> <p>ENF. TRANS.: SI ENF. MOTOR: NO</p> <p>TOMAS: ENTRADA: 1 5/16" SALIDA: 1 5/16"</p> <p>005</p>	<p>A2728-13C BUICK/CHEVROLET/GMC/PONTIAC</p>  <p>Toma hacia arriba</p> <p>Montajes para abanicos</p> <p>RENDEZVOUS 02-07/AZTEK/VENTURE/IMPALA 01-05</p> <p>7033 PHAR V6 3.4/3.5</p> <p>PANAL: 30 1/2" X 15" X 1/2" CAB. SUP.: 2 1/2" X 15 3/8" CAB. INF.: 2 1/2" X 15 3/8"</p> <p>ENF. TRANS.: SI ENF. MOTOR: NO</p> <p>TOMAS: ENTRADA: 1 5/16" SALIDA: 1 5/16"</p> <p>CONDENSADOR: AC3050</p> <p>006</p>
<p>A2728-28C BUICK/CHEVROLET/GMC/PONTIAC</p>  <p>Toma hacia arriba</p> <p>Montajes para abanicos</p> <p>RENDEZVOUS 02-07/AZTEK/VENTURE/IMPALA 01-05</p> <p>7033 PHAR V6 3.4/3.5</p> <p>PANAL: 30 1/2" X 15" X 1 1/8" CAB. SUP.: 2 1/2" X 15 3/8" CAB. INF.: 2 1/2" X 15 3/8"</p> <p>ENF. TRANS.: SI ENF. MOTOR: NO</p> <p>TOMAS: ENTRADA: 1 5/16" SALIDA: 1 5/16"</p> <p>CONDENSADOR: AC3050</p> <p>007</p>	<p>A2881-28C BUICK/CHEVROLET/GMC</p>  <p>Toma superior hacia adentro</p> <p>Conexión rápida</p> <p>TERRAZA 06-07/MONTANA 06-09/UPLANDER 06-09</p> <p>2881 PHAR V6 3.9</p> <p>PANAL: 30 1/2" X 15" X 1 1/8" CAB. SUP.: 2 1/2" X 15 3/8" CAB. INF.: 2 1/2" X 15 3/8"</p> <p>ENF. TRANS.: SI ENF. MOTOR: NO</p> <p>TOMAS: ENTRADA: 1 1/4" SALIDA: 1 1/4"</p> <p>008</p>	<p>A13007-28C BUICK/CHEVROLET/GMC/SATURN</p>  <p>Gollete roscado</p> <p>Conexiones de candado</p> <p>ENCLAVE 08-13 / TRAVERSE 09-12 / ACADIA 07-13 / OUTLOOK 07-10</p> <p>DPI 13007 V6 3.6</p> <p>PANAL: 27 1/2" X 18 3/4" X 1 1/8" CAB. SUP.: 2 5/16" X 19 15/16" CAB. INF.: 2 5/16" X 19 15/16"</p> <p>ENF. TRANS.: SI ENF. MOTOR: NO</p> <p>TOMAS: ENTRADA: 1 5/16" SALIDA: 1 5/16"</p> <p>CONDENSADOR: AC3649</p> <p>009</p>

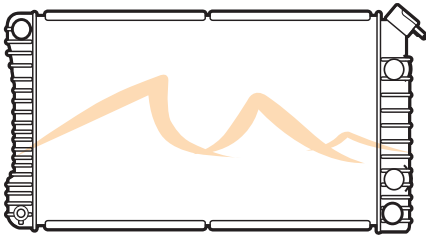
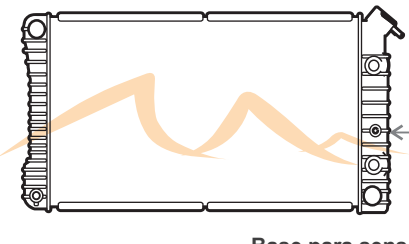
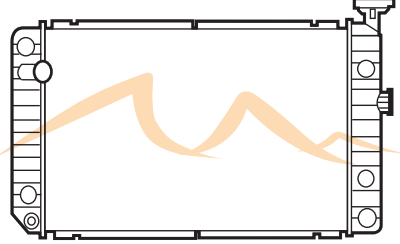
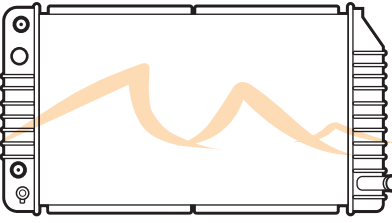
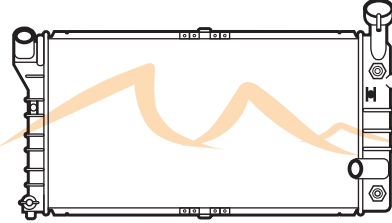
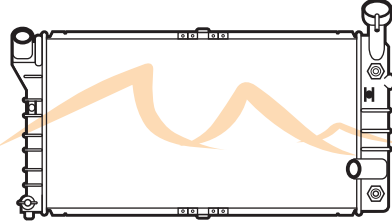
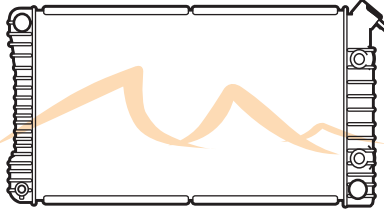
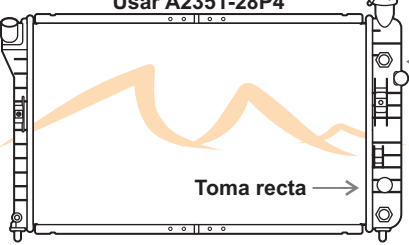
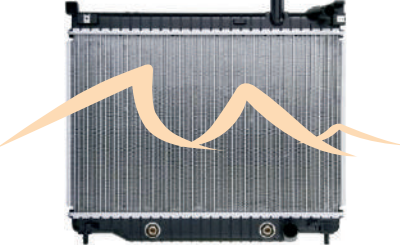
0767 DPI BUICK	1202 DPI BUICK / OLDSMOBILE	1206 DPI BUICK/CHEVROLET/GM
		
LESABRE 91-95	88/BONEVILLE/REGENCY 91-99	LUMINA/CUTLASS 91-93
1738 PHAR V6 3.8 PANAL: 30 1/2" X 17 1/4" X 1" (26 mm) CAB. SUP.: 2 1/2" X 18 5/8" CAB. INF.: 2 1/2" X 18 5/8" ENF. TRANS.: 11 1/2" 4 PLACAS ENF. MOTOR: NO NOTAS: Puede usar HD 2025	2415 PHAR V6 3.8 PANAL: 30 1/2" X 17 1/4" X 1" (26 mm) CAB. SUP.: 2 1/2" X 18 3/4" CAB. INF.: 2 1/2" X 18 3/4" ENF. TRANS.: 11 1/2" 4 PLACAS ENF. MOTOR: NO NOTAS: Sustituye 1684 WO/LCI PLUG	6009 PHAR V6 3.8 PANAL: 28 1/4" X 15" X 1" (26 mm) CAB. SUP.: 2 1/2" X 16 1/2" CAB. INF.: 2 1/2" X 16 1/2" ENF. TRANS.: 11 1/2" 4 PLACAS ENF. MOTOR: NO
010	011	012
1344 DPI BUICK/CHEVROLET/GM	1518 DPI BUICK/CHEVROLET/GM	1519 DPI BUICK/CHEVROLET/GM
		
BERETTA/CORSICA 92-94	LUMINA 94-97	LUMINA 94-01
2276 PHAR V6 3.8 PANAL: 26" X 15" X 1 3/8" CAB. SUP.: 2 1/2" X 16 1/2" CAB. INF.: 2 1/2" X 16 1/2" ENF. TRANS.: 11 1/2" 3 PLACAS ENF. MOTOR: NO NOTAS: Puede usar 1341	6019 PHAR V6 3.8 PANAL: 30 1/2" X 15 X 1" CAB. SUP.: 2 1/2" X 16 5/8" CAB. INF.: 2 1/2" X 16 5/8" ENF. TRANS.: 11 1/2" 4 PLACAS EN. MOTOR: NO	6019 PHAR L6 2.5/2.8/3.0 PANAL: 30 1/2" X 15" X 5/8" (16 mm) CAB. SUP.: 2 1/2" X 16 5/8" CAB. INF.: 2 1/2" X 16 5/8" ENF. TRANS.: 11 1/2" 4 PLACAS ENF. MOTOR: NO
013	014	015
1684 DPI BUICK/OLDSMOBILE	2343 DPI BUICK/CHEVROLET/GM	2563 DPI BUICK/CHEVROLET/GM
		
LESABRE/REGENCY 96-99/97-98	CENTURY/IMPALA 00-05/00-03	DENALI 04-07/RAINIER/TRAIL BLAZER 06-09
V6 3.8 PANAL: 30 1/2" X 17 3/8" X 1" (26 mm) CAB. SUP.: 2 1/4" X 18 5/8" CAB. INF.: 2 1/4" X 18 5/8" ENF. TRANS.: 11 1/2" 4 PLACAS ENF. MOTOR: NO	V8 4.6/3.1/3.4/3.8 PANAL: 30 1/2" X 15 1/16" X 5/8" (16 mm) CAB. SUP.: 2 5/16" X 16 7/16" CAB. INF.: 2 5/16" X 16 7/16" ENF. TRANS.: 11 1/2" 3 PLACAS ENF. MOTOR: NO	V8 5.3/6.0 PANAL: 27 5/8" X 13 11/16" X 1 1/16" CS: 2 3/16" X 27 3/8" CI: 2 3/16" X 27 3/8" EDA: 11 1/2" EDAM: NO
016	017	018

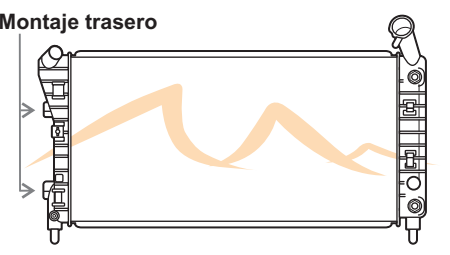
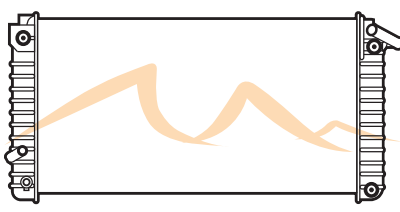
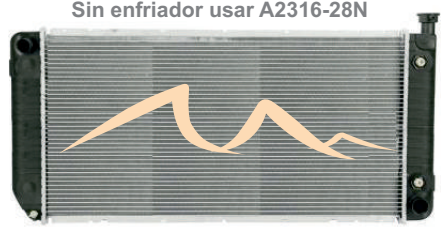
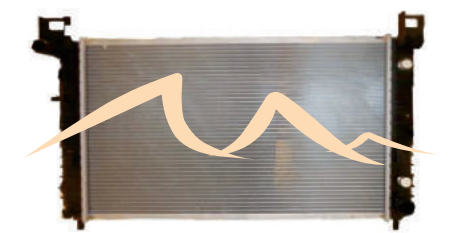
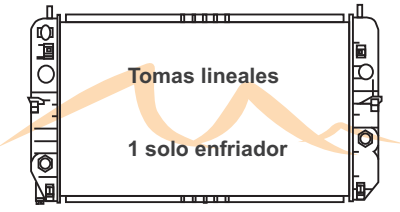
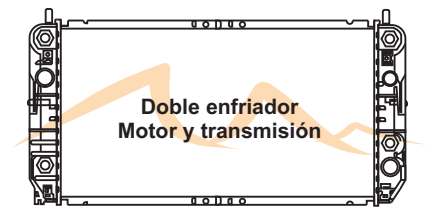
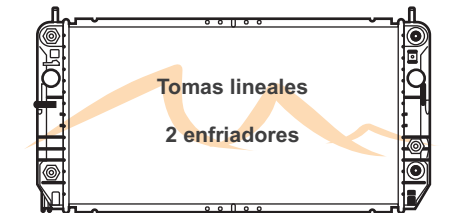
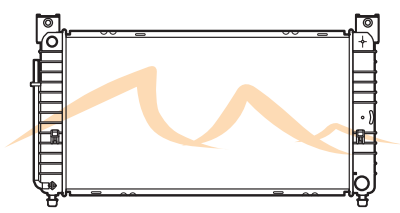
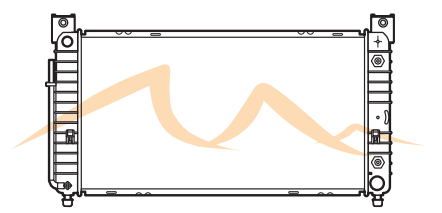
<p>2710 DPI BUICK/CHEVROLET/GM/PONTIAC</p> <p>Montaje trasero</p>  <p>ALLURE/LA CROSSE 05-09/IMPALA/MONTECARLO 04-05</p> <p>V6 3.4/3.8</p> <p>PANAL: 30 1/2" X 14 9/16" X 5/8" (16 mm) CAB. SUP.: 1 7/8" X 14 15/16" CAB. INF.: 1 7/8" X 14 15/16" ENF. TRANS.: SI ENF. MOTOR: NO</p> <p>TOMAS: ENTRADA: 1 5/16" SALIDA: 1 5/16"</p> <p>019</p>	<p>A1482-28P3 CADILLAC</p>  <p>DEVILLE/EL DORADO 93-02</p> <p>6020 PHAR / DPI 1482</p> <p>V8 4.6</p> <p>PANAL: 30 1/2" X 15" X 1 1/8" CAB. SUP.: 2 1/2" X 16 5/8" CAB. INF.: 2 1/2" X 16 5/8" ENF. TRANS.: SI ENF. MOTOR: SI</p> <p>ENTRADA: 1 9/16" SALIDA: 1 3/8"</p> <p>020</p>	<p>A2317-28C CADILLAC/CHEVROLET/GMC</p>  <p>Sin enfriador usar A2316-28N</p> <p>SERIES PICK UP/CHEYENNE/SILVERADO 96-04 SIERRA /YUKON 96-99/ESCALADE 99-00</p> <p>V8 5.0/5.7</p> <p>PANAL: 34" X 17 3/8" X 1 1/8" CAB. SUP.: 18 3/8" X 3 1/8" CAB. INF.: 18 3/8" X 3 1/8" ENF. TRANS.: SI 756597-M ENF. MOTOR: NO</p> <p>TOMAS: ENTRADA: 1 5/16" SALIDA: 1 9/16"</p> <p>021</p>
<p>A2334-28C CADILLAC/CHEVROLET</p>  <p>ESCALADE 05/SILVERADO 1500, 2500 99-13</p> <p>V6 4.3 V8 4.8/5.3/6.0/6.2</p> <p>PANAL: 28 9/16" X 17 1/4" X 1 1/8" CAB. SUP.: 18 3/4" X 2 7/16" CAB. INF.: 18 3/4" X 2 7/16" ENF. TRANS.: SI ENF. MOTOR: NO</p> <p>TOMAS: ENTRADA: 1 9/16" SALIDA: 1 5/16"</p> <p>CONDENSADOR: AC3026/AC4953</p> <p>022</p>	<p>A2352-13C CADILLAC</p>  <p>Tomas lineales 1 solo enfriador</p> <p>DEVILLE 2000</p> <p>DPI 2352</p> <p>V8 4.6</p> <p>PANAL: 15 1/4" X 30 3/8" X 1/2" CAB. SUP.: 2 3/8" X 16 7/16" CAB. INF.: 2 3/8" X 16 1/2" ENF. TRANS.: NO ENF. MOTOR: NO</p> <p>TOMAS: ENTRADA: 1 3/8" SALIDA: 1 1/2"</p> <p>023</p>	<p>A2369-28C CADILLAC/CHEVROLET/GMC</p>  <p>Doble enfriador Motor y transmisión</p> <p>DEVILLE</p> <p>DPI 2369</p> <p>V8 4.6</p> <p>PANAL: 30 9/16" X 14 7/8" X 1 1/8" CAB. SUP.: 2 3/8" X 16 7/16" CAB. INF.: 2 3/8" X 16 7/16" ENF. TRANS.: SI ENF. MOTOR: NO</p> <p>TOMAS: ENTRADA: 1 1/2" SALIDA: 1 3/8"</p> <p>TOC: 101050 EOC: 1016475</p> <p>024</p>
<p>A2369-28P3 CADILLAC</p>  <p>Tomas lineales 2 enfriadores</p> <p>DEVILLE 2000</p> <p>DPI 2369</p> <p>V8 4.6</p> <p>PANAL: 30 1/2" X 15 5/16" X 1 1/8" (28 mm) CAB. SUP.: 2 7/16" X 16 9/16" CAB. INF.: 2 7/16" X 16 9/16" ENF. TRANS.: SI ENF. MOTOR: SI</p> <p>TOMAS: ENTRADA: 1 5/16" SALIDA: 1 9/16"</p> <p>025</p>	<p>A2423-28N CADILLAC/CHEVROLET/GMC</p>  <p>Sin enfriador</p> <p>SUBURBAN/ESCALADE 99-13/SILVERADO/SIERRA/YUKON 99-07</p> <p>DPI 2423</p> <p>V8 5.3/6.0/6.2</p> <p>PANAL: 34" X 17 1/2" X 1 1/8" CAB. SUP.: 3 3/16" X 18 5/8" CAB. INF.: 3 3/16" X 18 5/8" ENF. TRANS.: NO ENF. MOTOR: NO</p> <p>TOMAS: ENTRADA: 1 5/16" SALIDA: 1 9/16"</p> <p>CONDENSADOR: AC3026/AC4953</p> <p>026</p>	<p>A2423-28C CADILLAC/CHEVROLET/GM</p>  <p>SILVERADO/ESCALADE 02-13/SIERRA/YUKON 99-07</p> <p>DPI 2423</p> <p>V8 4.8/5.3/6.0/6.2</p> <p>PANAL: 34" X 17 1/2" X 1 1/8" CAB. SUP.: 2 5/16" X 18 9/16" CAB. INF.: 2 5/16" X 18 9/16" ENF. TRANS.: SI ENF. MOTOR: NO</p> <p>TOMAS: ENTRADA: 1 5/16" SALIDA: 1 5/16"</p> <p>CONDENSADOR: AC3026/AC4953</p> <p>027</p>

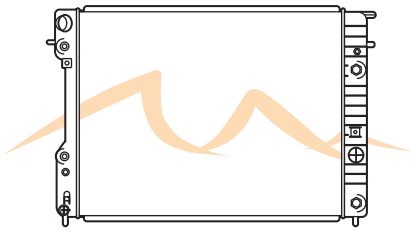
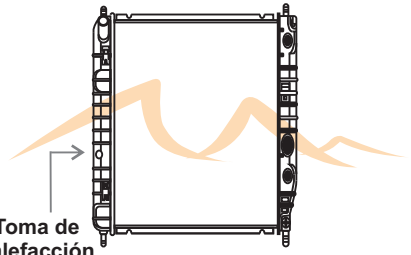
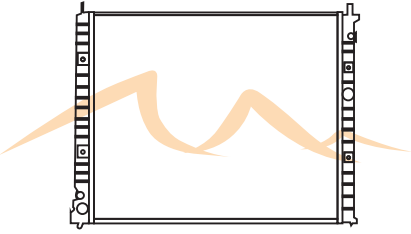
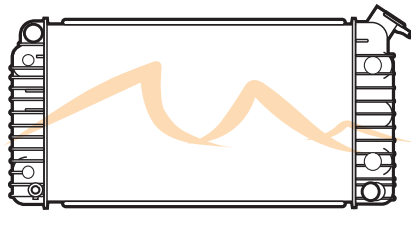
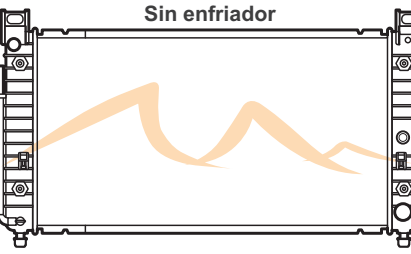
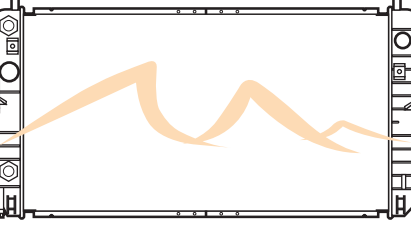
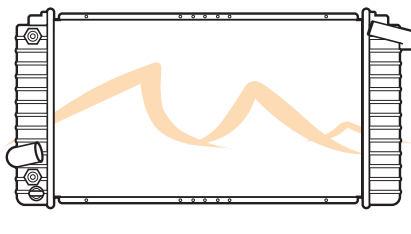
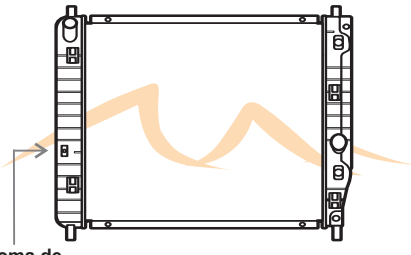
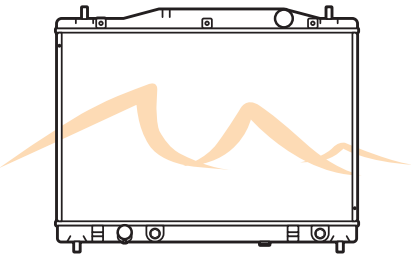
<p>A2595-28C CADILLAC</p>  <p>CATERA 00-01</p> <p>7016 PHAR / DPI 2595 V6 3.0</p> <p>PANAL: 25 3/4" X 18 1/8" X 1 1/8" CAB. SUP.: 2 3/8" X 18 5/8" CAB. INF.: 2 3/8" X 18 5/8" ENF. TRANS.: SI ENF. MOTOR: NO</p> <p>TOMAS: ENTRADA: 1 3/8" SALIDA: 1 3/8"</p> <p>028</p>	<p>A2715-28P3 CADILLAC/CHEVROLET/GMC</p>  <p>CADILLAC XLR 04-09</p> <p>2715 PHAR V8 4.4/4.6</p> <p>PANAL: 23 1/2" X 18 1/2" X 1 1/8" CAB. SUP.: 2 5/16" X 18 9/16" CAB. INF.: 2 5/16" X 18 9/16" ENF. TRANS.: SI 3 PLACAS ENF. MOTOR: NO</p> <p>TOMAS: ENTRADA: 1 3/8" SALIDA: 1 3/8"</p> <p>029</p>	<p>A13055-28C CADILLAC</p>  <p>CTS 08-12</p> <p>DPI 13055AR V6 3.0/3.6</p> <p>PANAL: 23 5/8" X 20 1/4" X 1 1/8" CAB. SUP.: 1 7/8" X 21 7/16" CAB. INF.: 1 7/8" X 21 7/16" ENF. TRANS.: SI ENF. MOTOR: NO</p> <p>TOMAS: ENTRADA: 1 3/8" SALIDA: 1 3/8"</p> <p>030</p>
<p>1474 DPI CADILLAC</p>  <p>DEVILLE 91-93</p> <p>1736 PHAR V8 4.9</p> <p>PANAL: 30 1/2" X 17 1/4" X 1 3/8" CAB. SUP.: 2 1/2" X 18 3/4" CAB. INF.: 2 1/2" X 18 3/4" ENF. TRANS.: 11 1/2" 4 PLACAS ENF. MOTOR: 11 1/2" 4 PLACAS</p> <p>NOTAS: Se puede usar 856</p> <p>TOMAS: ENTRADA: 1 1/4" SALIDA: 1 5/8"</p> <p>031</p>	<p>2370 DPI CADILLAC/CHEVROLET/GM</p>  <p>ESCALADE/YUKON/TAHOE 02-13/99-14</p> <p>CONDENSADOR: AC3026</p> <p>V8 4.8/5.3/6.0/6.2</p> <p>PANAL: 34" X 17 1/2" X 1" (26 mm) CAB. SUP.: 3 3/16" X 18 5/8" CAB. INF.: 3 3/16" X 18 5/8" ENF. TRANS.: 11 1/2" 7 PLACAS ENF. MOTOR: 11 1/2" 6 PLACAS</p> <p>TOMAS: ENTRADA: 1 5/16" SALIDA: 1 9/16"</p> <p>032</p>	<p>2513 DPI CADILLAC</p>  <p>SEVILLE STS/SLS 01-04</p> <p>V8 4.6</p> <p>PANAL: 30 1/2" X 15 5/16" X 1 1/4" (32 mm) CAB. SUP.: 2 7/16" X 16 9/16" CAB. INF.: 2 7/16" X 16 9/16" ENF. TRANS.: 11 1/2" 3 PLACAS ENF. MOTOR: NO</p> <p>TOMAS: ENTRADA: 1 5/16" SALIDA: 1 9/16"</p> <p>033</p>
<p>2517 DPI CADILLAC</p>  <p>EL DORADO 01-02</p> <p>V8 4.6</p> <p>Doble enfriador usar: A1482-28P3</p> <p>PANAL: 30 1/2" X 14 7/8" X 1 1/4" (32 mm) CAB. SUP.: 16 3/8" X 2 9/32" CAB. INF.: 16 3/8" X 2 9/32" ENF. TRANS.: 11 1/2" ENF. MOTOR: NO</p> <p>TOMAS: ENTRADA: 1 5/16" SALIDA: 1 9/16"</p> <p>034</p>	<p>2715 DPI CADILLAC</p>  <p>CADILLAC XLR 04-09</p> <p>V8 4.4/4.6</p> <p>PANAL: 23 1/2" X 17 3/16" X 1" (26 mm) CAB. SUP.: 2 5/16" X 18 5/8" CAB. INF.: 2 5/16" X 18 5/8" ENF. TRANS.: SI ENF. MOTOR: NO</p> <p>TOMAS: ENTRADA: 1 5/16" SALIDA: 1 5/16"</p> <p>035</p>	<p>2731 DPI CADILLAC</p>  <p>CADILLAC CTS 04-07</p> <p>V6 2.8/3.6 V8 5.7/6.0</p> <p>PANAL: 16 3/4" X 26" X 1" (26 mm) CAB. SUP.: 1 7/8" X 26 11/16" CAB. INF.: 1 7/8" X 26 11/16" ENF. TRANS.: SI ENF. MOTOR: NO</p> <p>TOMAS: ENTRADA: 1 3/8" SALIDA: 1 3/8"</p> <p>036</p>

2921 DPI CADILLAC/CHEVROLET/GMC

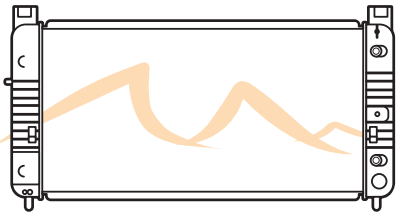

SUBURBAN/TAHOE/YUKON 00-07
V8 4.8/5.3/6.0/6.2

PANAL: 34" X 17 1/2" X 1" (26 mm)
CAB. SUP.: 3 3/16" X 18 5/8"
CAB. INF.: 3 3/16" X 18 5/8"
ENF. TRANS.: SI 7 PLACAS
ENF. MOTOR: NO

TOMAS:
ENTRADA: 1 5/16"
SALIDA: 1 9/16"

037

13349 DPI CADILLAC

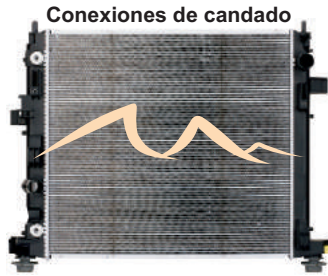

ATS 13-15 / CTS 14-15
L4 2.0 / 2.5 / V6 3.6

PANAL: 20 11/16" X 18 7/8" X 1"
CAB. SUP.: 1 15/16" X 20"
CAB. INF.: 1 15/16" X 20"
ENF. TRANS.: SI
ENF. MOTOR: NO

TOMAS:
ENTRADA: 1 3/8"
SALIDA: 1 3/8"

038

**PRUEBA NUESTRA
VERSION IMPRESA
EN LINEA**

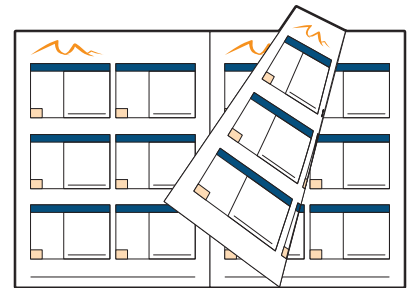



www.phar.com.mx

NOTAS

Radiadores

PHAR

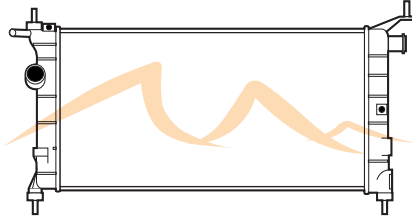
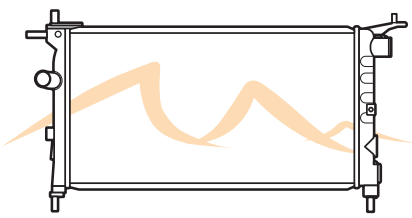
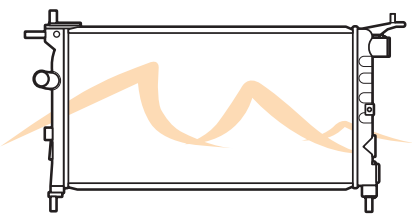
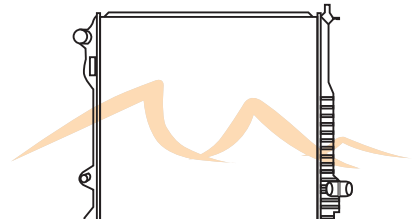
- CHEVROLET

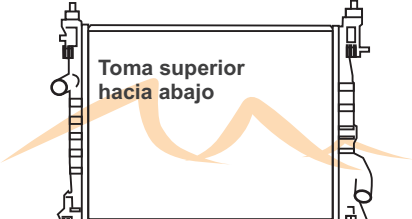
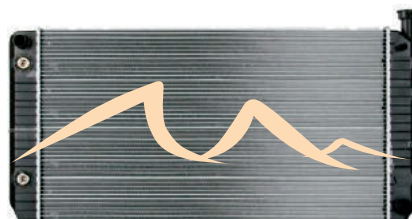
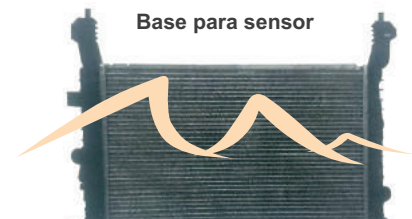
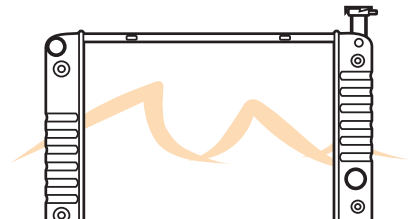

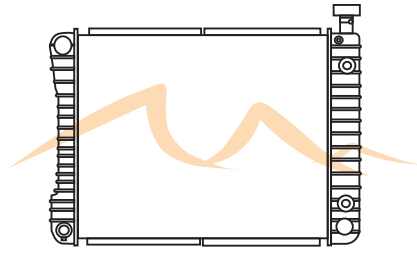
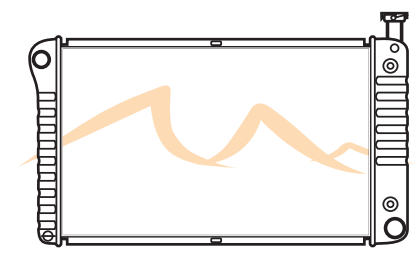
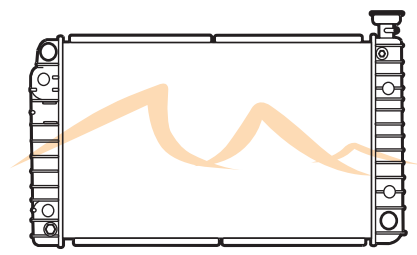
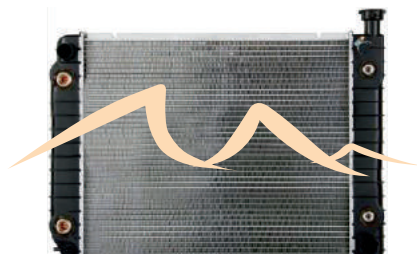
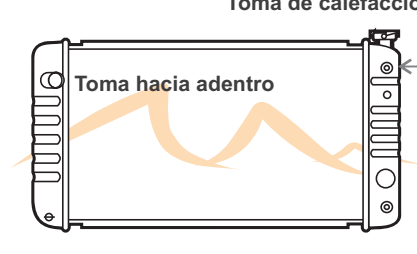
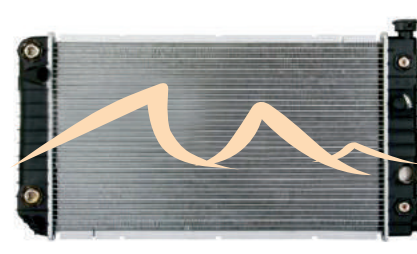
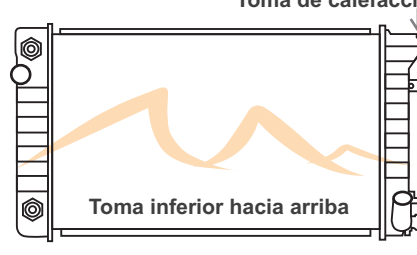
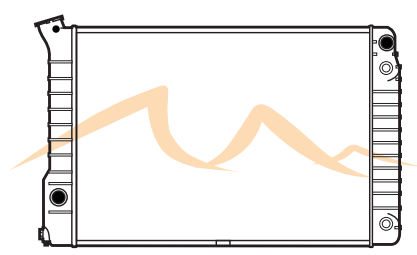
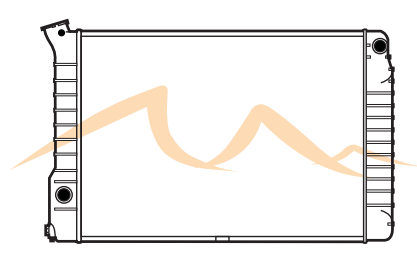
<p>A005-13C CHEVROLET/GMC</p>  <p>CHEVY JOY 98-04</p> <p>2410 PHAR 1.2/1.4 16V</p> <p>PANAL: 20 7/8" X 10 1/2" X 1 1/4" CAB. SUP.: 1 3/4" X 11 3/16" CAB. INF.: 1 3/4" X 11 3/16" ENF. TRANS.: NO ENF. MOTOR: NO</p> <p>TOMAS: ENTRADA: 1 3/8" SALIDA: 1 3/8"</p> <p>001</p>	<p>A005-13N CHEVROLET/GMC</p>  <p>CHEVY JOY/SWING 94-03</p> <p>2410 PHAR 1.2/1.4 16V</p> <p>PANAL: 20 3/4" X 11 9/16" X 1/2" CAB. SUP.: 1 15/16" X 11 1/16" CAB. INF.: 1 15/16" X 11 1/16" ENF. TRANS.: NO ENF. MOTOR: NO</p> <p>TOMAS: ENTRADA: 1 3/8" SALIDA: 1 3/8"</p> <p>002</p>	<p>A005-21N CHEVROLET/GMC</p>  <p>CHEVY JOY/SWING 94-03</p> <p>2410 PHAR 1.2/1.4 16V</p> <p>PANAL: 20 3/4" X 11 9/16" X 13/16" CAB. SUP.: 1 15/16" X 11 1/16" CAB. INF.: 1 15/16" X 11 1/16" ENF. TRANS.: NO ENF. MOTOR: NO</p> <p>TOMAS: ENTRADA: 1 3/8" SALIDA: 1 3/8"</p> <p>003</p>
<p>A014-13N CHEVROLET/GMC</p>  <p>MATIZ 06-09</p> <p>L4 1.0</p> <p>PANAL: 18" X 13 7/8" CAB. SUP.: 1 7/16" X 13 3/8" CAB. INF.: 1 7/16" X 13 3/8" ENF. TRANS.: NO ENF. MOTOR: NO</p> <p>TOMAS: ENTRADA: 1 1/8" SALIDA: 1 1/8"</p> <p>004</p>	<p>A017-13P3 CHEVROLET/GMC</p>  <p>CRUZE 05-12</p> <p>L4 1.6/1.8</p> <p>PANAL: 22 3/4" X 15 5/8" X 1/2" CAB. SUP.: 1 7/8" X 16 1/16" CAB. INF.: 1 7/8" X 16 1/16" ENF. TRANS.: SI 101050 ENF. MOTOR: NO</p> <p>TOMAS: ENTRADA: 1 1/2" SALIDA: 1 3/8"</p> <p>005</p> <p>Montajes largos lado piloto</p>	<p>A022-13N CHEVROLET</p>  <p>SPARK GT 10-13</p> <p>L4 1.2</p> <p>PANAL: 17 3/4" X 15 1/4" X 1/2" CAB. SUP.: 1 1/2" X 16 5/8" CAB. INF.: 1 1/2" X 16 5/8" ENF. TRANS.: NO ENF. MOTOR: NO</p> <p>TOMAS: ENTRADA: 1 1/4" SALIDA: 1 1/4"</p> <p>006</p> <p>Toma superior hacia abajo</p>
<p>A028-44P3 CHEVROLET/GMC</p>  <p>C350HD, C2500, K3500, K2500 95-97</p> <p>2509 PHAR V8 7.4</p> <p>PANAL: 34" X 19 3/16" X 1 3/4" CAB. SUP.: 3 3/16" X 20 11/16" CAB. INF.: 3 3/16" X 20 11/16" ENF. TRANS.: NO ENF. MOTOR: SI</p> <p>TOMAS: ENTRADA: 1 1/4" SALIDA: 1 1/2"</p> <p>007</p>	<p>A056-28N CHEVROLET</p>  <p>OPEL/MERIVA 03-10</p> <p>1.7 TDi</p> <p>PANAL: 23 15/16" X 14 1/8" X 1 1/8" CAB. SUP.: 14 3/4" X 2 1/8" CAB. INF.: 14 3/4" X 2 1/8" ENF. TRANS.: NO</p> <p>TOMAS: ENTRADA: 1 3/8" SALIDA: 1 3/8"</p> <p>008</p> <p>Base para sensor</p> <p>Toma abajo lado copiloto</p>	<p>A0312-28P3 CHEVROLET/GMC</p>  <p>ASTRO/SAFARI VAN 85-94</p> <p>2501 PHAR / DPI 312 V6 4.3</p> <p>PANAL: 23 5/8" X 17 1/4" X 1 1/8" CAB. SUP.: 2 1/2" X 18 5/8" CAB. INF.: 2 1/2" X 18 5/8" ENF. TRANS.: SI ENF. MOTOR: SI</p> <p>TOMAS: ENTRADA: 1 1/4" SALIDA: 1 1/2"</p> <p>009</p>

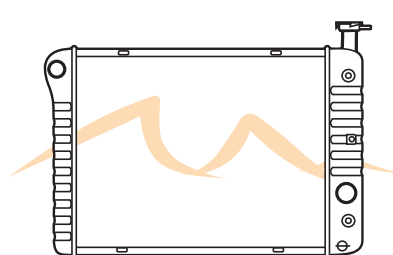
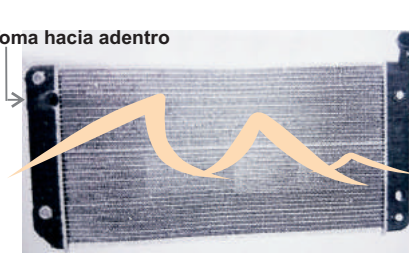
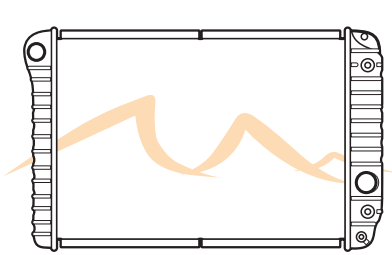
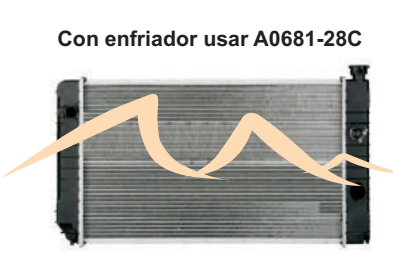
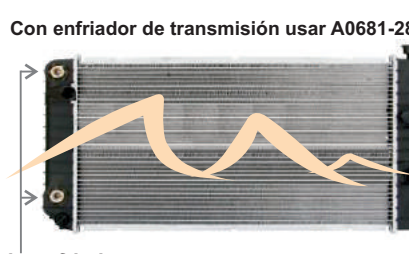
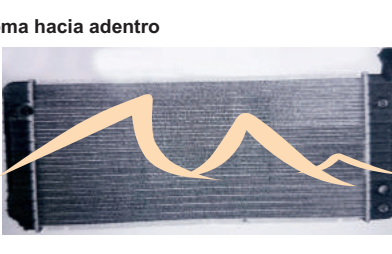
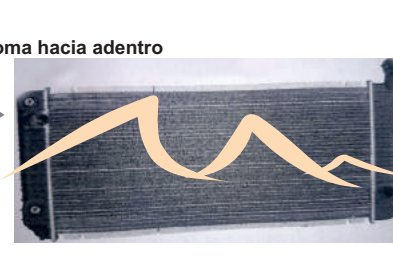
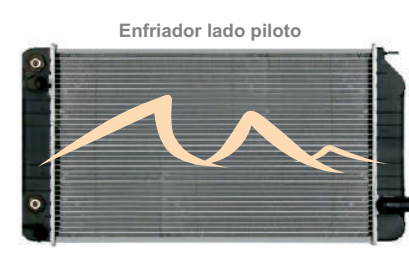
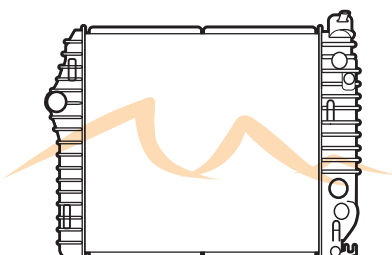
<p>A0434-28C CHEVROLET/GMC</p>  <p>C/K SERIES/SIERRA/SUBURBAN 88-95 V6 4.3 V8 5.0/5.7</p> <p>PANAL: 20 5/8" X 18 1/2" X 1 1/8" CAB. SUP.: 1 7/8" X 14 7/8" CAB. INF.: 2 5/16" X 18 9/16" ENF. TRANS.: SI ENF. MOTOR: NO</p> <p>TOMAS: ENTRADA: 1 9/16" SALIDA: 1 5/16"</p> <p>010</p>	<p>A0618-28C CHEVROLET/GMC</p>  <p>C/K SERIES PICK UP 88-95 V6 4.3 V8 5.0/5.7</p> <p>2504 PHAR / DPI 618</p> <p>PANAL: 28 1/4" X 17 1/4" X 1 1/8" CAB. SUP.: 2 1/2" X 18 3/4" CAB. INF.: 2 1/2" X 18 3/4" ENF. TRANS.: SI ENF. MOTOR: NO</p> <p>TOMAS: ENTRADA: 1 5/16" SALIDA: 1 9/16"</p> <p>011</p>	<p>A0622-28P3 CHEVROLET/GMC</p>  <p>C/K SERIES PICK UP 88-95 V6 4.3 V8 5.0/5.7</p> <p>1735 PHAR / DPI 622</p> <p>PANAL: 28 1/4" X 17 1/4" X 1 1/8" CAB. SUP.: 2 1/2" X 18 3/4" CAB. INF.: 2 1/2" X 18 3/4" ENF. TRANS.: SI ENF. MOTOR: SI</p> <p>TOMAS: ENTRADA: 1 1/4" SALIDA: 1 1/2"</p> <p>012</p>
<p>A0677-28P3 CHEVROLET/GM</p>  <p>C/K SERIES PICK UP 88-93 DPI 677 / 6023 PHAR V6 4.3 V8 5.0/5.7</p> <p>PANAL: 20 3/4" X 17 1/4" X 1 3/8" CS: 2 1/2" X 18 3/4" CI: 2 1/2" X 18 3/4" EDA: 11 1/2" 4 PLACAS EDAM: 11 1/2" 3 PLACAS NOTAS: Substitute 1217</p> <p>013</p>	<p>A0681-28C CHEVROLET/GMC/OLDSMOBILE</p>  <p>JIMMY S15 SONOMA SYCLONE 88-94 / S10 BLAZER 88-94 / BRAVADA 91-94 DPI 681 V6 4.3</p> <p>PANAL: 26 3/16" 14 3/8" X 1 1/8" CAB. SUP.: 2 5/16" X 16 3/8" CAB. INF.: 2 5/16" X 6 3/8" ENF. TRANS.: SI ENF. MOTOR: NO</p> <p>TOMAS: ENTRADA: 1 5/16" SALIDA: 1 9/16"</p> <p>014</p>	<p>A0705-28P3 CHEVROLET/GM</p>  <p>S10/BLAZER/JIMMY/SONOMA 88-94/ 91-94 2605 PHAR V6 4.3</p> <p>PANAL: 26 1/4" X 14 5/8" X 1 1/8" CS: 2 3/8" X 16 7/16" CI: 2 3/8" X 16 7/16" EDA: 11 1/2" EDAM: 11 1/2"</p> <p>ENTRADA: 1 5/16" SALIDA: 1 9/16"</p> <p>015</p>
<p>A0768-28C CHEVROLET/PONTIAC</p>  <p>CAVALIER 89-94 / SUNBIRD 91-94 DPI 768 V6 2.8/3.1</p> <p>PANAL: 23 1/2" X 14" X 1 1/8" CAB. SUP.: 2 1/2" X 15 3/4" CAB. INF.: 2 1/2" X 15 3/4" ENF. TRANS.: SI ENF. MOTOR: NO</p> <p>TOMAS: ENTRADA: 1 5/16" SALIDA: 1 5/16"</p> <p>016</p>	<p>A0888-28C CHEVROLET/GMC</p>  <p>S/T SERIES PICK UP 82-93 2209 PHAR / DPI 888 L4 2.2 V6 2.8</p> <p>PANAL: 23 5/8" X 14 7/8" X 1 1/8" CAB. SUP.: 2 5/16" X 16 7/16" CAB. INF.: 2 3/8" X 16 7/16" ENF. TRANS.: NO ENF. MOTOR: NO</p> <p>TOMAS: ENTRADA: 1 1/4" SALIDA: 1 1/4"</p> <p>017</p>	<p>A0888-28N CHEVROLET/GMC</p>  <p>S/T SERIES PICK UP 82-93 2209 PHAR / DPI 744 L4 2.2 V6 2.8</p> <p>PANAL: 23 5/8" X 14 7/8" X 1 1/8" CAB. SUP.: 2 5/16" X 16 7/16" CAB. INF.: 2 3/8" X 16 7/16" ENF. TRANS.: NO ENF. MOTOR: NO</p> <p>TOMAS: ENTRADA: 1 1/4" SALIDA: 1 1/4"</p> <p>018</p>

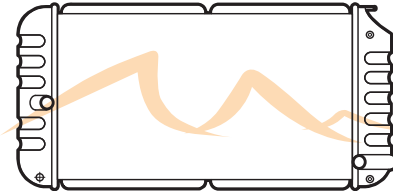
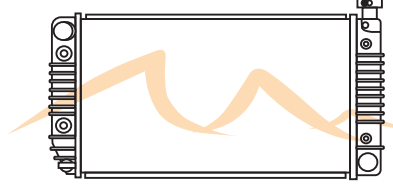
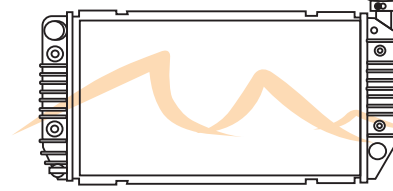
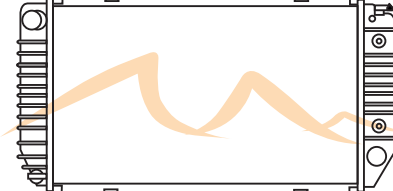
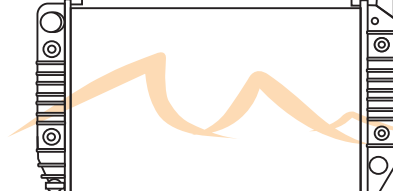
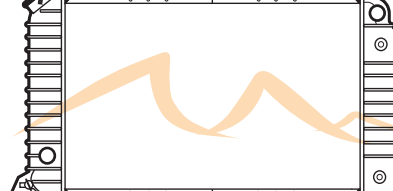
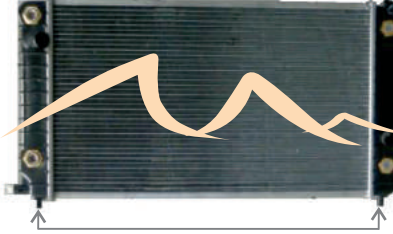
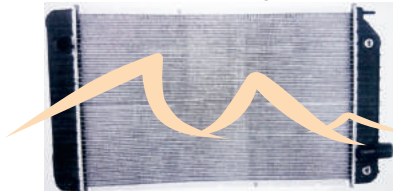
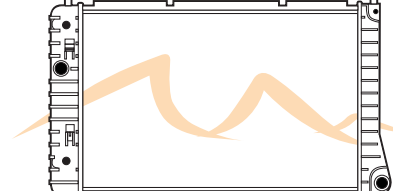
<p>A0924-28C CHEVROLET/GMC</p>  <p>ASTRO/SAFARI 85-94</p> <p>2500 PHAR / DPI 924 V6 4.3</p> <p>PANAL: 23 5/8" X 17 1/4" X 1 1/8" CAB. SUP.: 2 1/2" X 18 5/8" CAB. INF.: 2 1/2" X 18 5/8" ENF. TRANS.: SI 756383 ENF. MOTOR: NO</p> <p>TOMAS: ENTRADA: 1 1/4" SALIDA: 1 1/2"</p> <p>019</p>	<p>A1051-28C BUICK/CHEVROLET PONTIAC/OLDSMOBILE</p>  <p>Toma hacia adentro</p> <p>Base hacia polvera</p> <p>REGAL CUSTOM 90-93/ LUMINA 91-93/ GRAND PRIX 91-93/CUTLASS 91-93</p> <p>DPI 1051 V6 3.1/3.4/3.8</p> <p>PANAL: 34 3/4" X 19 1/16" X 5" CAB. SUP.: 16 3/8" X 2 5/16" CAB. INF.: 16 3/8" X 2 5/16" ENFRIADOR: SI DOBLE</p> <p>TOMAS: ENTRADA: 1 5/16" SALIDA: 1 5/16"</p> <p>020</p>	<p>A1052-28C CHEVROLET/GMC</p>  <p>CORVETTE 89-96</p> <p>2407 PHAR / DPI 1052 V8 5.7</p> <p>PANAL: 23 5/8" X 17 1/4" X 1 1/8" CAB. SUP.: 2 1/2" X 18 3/4" CAB. INF.: 2 1/2" X 18 3/4" ENF. TRANS.: NO ENF. MOTOR: SI</p> <p>TOMAS: ENTRADA: 1 7/16" SALIDA: 1 11/16"</p> <p>021</p>
<p>A1060-28N CHEVROLET</p>  <p>Con enfriador usar A0681-28C</p> <p>S10/BLAZER 90-94/GMC JIMMY 92-94/S15/SONOMA 90-93</p> <p>V6 4.3</p> <p>PANAL: 26 1/4" X 15 3/16" X 1 1/8" CAB. SUP.: 2 5/16" X 16 3/8" CAB. INF.: 2 5/16" X 16 3/8" ENFRIADOR: NO</p> <p>TOMAS: ENTRADA: 1 5/16" SALIDA: 1 9/16"</p> <p>022</p>	<p>A1065-28C CHEVROLET/GMC</p>  <p>Con enfriador de transmisión usar A0681-28C</p> <p>Solo enfriador de motor</p> <p>SONOMA 93/JIMMY 91-94/S10/S15</p> <p>DPI 1065 V6 4.3</p> <p>PANAL: 26 1/4" X 15 3/16" X 1 1/8" CAB. SUP.: 2 5/16" X 16 3/8" CAB. INF.: 2 5/16" X 16 3/8" ENFRIADOR: SI</p> <p>TOMAS: ENTRADA: 1 5/16" SALIDA: 1 9/16"</p> <p>023</p>	<p>A1206-28C BUICK/CHEVROLET PONTIAC/OLDSMOBILE</p>  <p>Toma hacia adentro</p> <p>Base sensor</p> <p>REGAL CUSTOM 90-93/ LUMINA 91-93/ GRAND PRIX 91-93/CUTLASS SUPREME 92</p> <p>DPI 1206 / PHAR 6009 V6 3.1</p> <p>PANAL: 34 3/4" X 19 1/16" X 5" CAB. SUP.: 16 3/8" X 2 5/16" CAB. INF.: 16 3/8" X 2 5/16" ENFRIADOR: SI</p> <p>TOMAS: ENTRADA: 1 5/16" SALIDA: 1 5/16"</p> <p>024</p>
<p>A1216-28C CHEVROLET PONTIAC/OLDSMOBILE</p>  <p>Toma hacia adentro</p> <p>Base sensor</p> <p>LUMINA 91-93/ GRAND PRIX 91-93/CUTLASS SUPREME 92</p> <p>DPI 1216 V6 3.1/3.4</p> <p>PANAL: 34 3/4" X 19 1/16" X 5" CAB. SUP.: 16 3/8" X 2 5/16" CAB. INF.: 16 3/8" X 2 5/16" ENFRIADOR: SI</p> <p>TOMAS: ENTRADA: 1 5/16" SALIDA: 1 5/16"</p> <p>025</p>	<p>A1344-28C BUICK/CHEVROLET OLDSMOBILE/PONTIAC</p>  <p>Enfriador lado piloto</p> <p>Toma curva hacia adentro 90°</p> <p>SKYLARK/BERETTA/CORSICA 92-93 ACHIEVA/GRAND AM 92-93</p> <p>DPI 1344 / PHAR 2276 L4 2.2/2.3 V6 3.1</p> <p>PANAL: 25 15/16" X 15 1/8" X 1 1/8" CS: 16 7/16" X 2 5/16" CI: 16 7/16" X 2 5/16" ENFRIADOR: SI 75999-M 03/15</p> <p>ENTRADA: 1 5/16" SALIDA: 1 5/16"</p> <p>026</p>	<p>A1485-28C GM / PONTIAC</p>  <p>CAMARO/FIRE BIRD 93-02</p> <p>2417 PHAR / DPI 1485 V6 3.4/3.8</p> <p>PANAL: 24 3/4" X 17 1/4" X 1 1/8" CAB. SUP.: 2 1/2" X 18 3/4" CAB. INF.: 2 1/2" X 18 3/4" ENF. TRANS.: SI ENF. MOTOR: NO</p> <p>TOMAS: ENTRADA: 1 5/16" SALIDA: 1 5/16"</p> <p>027</p>

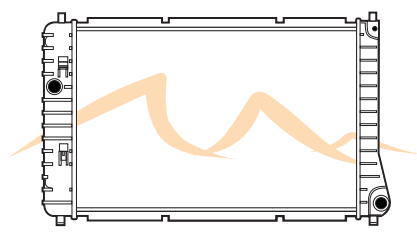
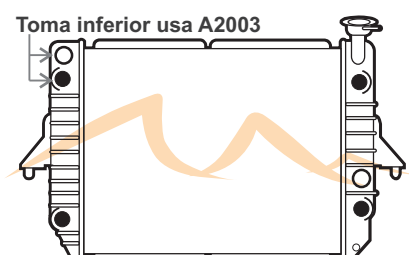
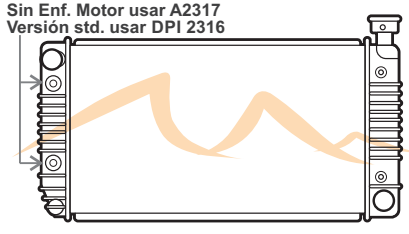
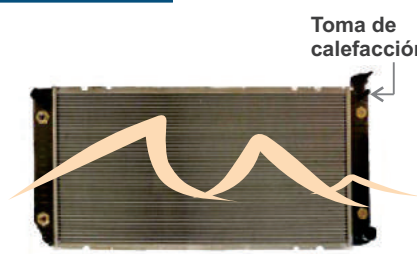
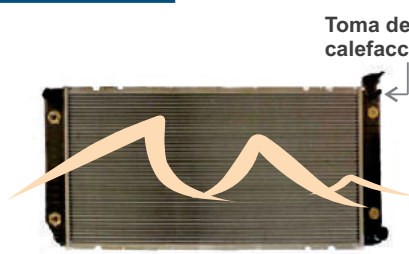
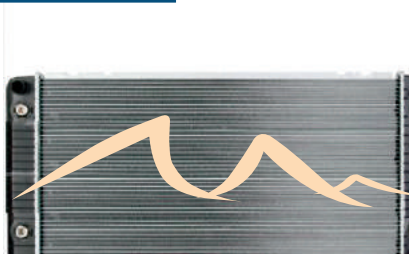
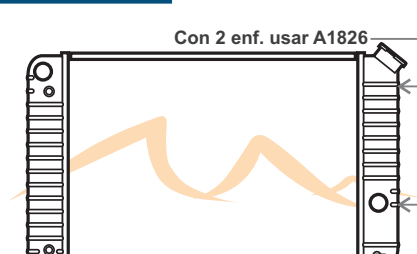
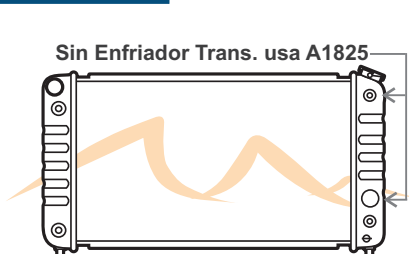
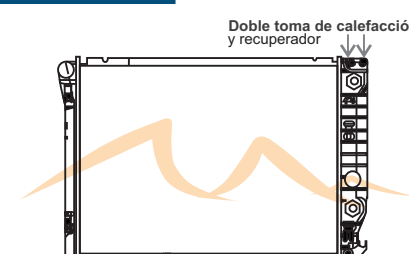
<p>A1515-28C CHEVROLET/GMC</p>  <p>CORSICA/BERETTA/GRAND AM 94-98</p> <p>2291 PHAR / DPI 1515 L4 2.2/2.3/2.4 V6 3.1</p> <p>PANAL: 26" X 15" X 1 1/8" CAB. SUP.: 2 1/2" X 16 5/8" CAB. INF.: 2 1/2" X 16 5/8" ENF. TRANS.: SI ENF. MOTOR: NO</p> <p>TOMAS: ENTRADA: 1 5/16" SALIDA: 1 5/16"</p> <p>028</p>	<p>A1520-44P3 CHEVROLET/GMC</p>  <p>SERIES C/K PICK UP / SUBURBAN 94-02</p> <p>1520 PHAR / DPI 1520 V8 5.0/5.7</p> <p>PANAL: 34" X 17 1/4" X 1 3/4" CAB. SUP.: 3" X 18 3/8" CAB. INF.: 3" X 18 3/8" ENF. TRANS.: SI ENF. MOTOR: NO TOC: 101051 / EOC: 1016475</p> <p>TOMAS: ENTRADA: 1 9/16" SALIDA: 1 5/16"</p> <p>029</p>	<p>A1521-60P3 CHEVROLET/GMC</p>  <p>Heavy Duty</p> <p>SUBURBAN JIMMY / C/K SERIES 94-00</p> <p>1521 PHAR / DPI 1521 V8 5.0/5.7/7.4</p> <p>PANAL: 34" X 19 3/16" X 2 3/8" CAB. SUP.: 3 1/4" X 20 3/4" CAB. INF.: 3 1/4" X 20 3/4" ENF. TRANS.: SI ENF. MOTOR: NO TOC: 101051 / EOC: 1016475</p> <p>TOMAS: ENTRADA: 1 5/16" SALIDA: 1 9/16"</p> <p>030</p>
<p>A1523-60P3 CHEVROLET/GMC</p>  <p>Heavy Duty</p> <p>TAHOE 94-99/ YUKON SERIES PICKUP 94-02</p> <p>1523 PHAR / DPI 1523 V8 6.5 DIESEL</p> <p>PANAL: 34" X 19 3/16" X 2 3/8" CAB. SUP.: 3" X 20 1/2" CAB. INF.: 3" X 20 1/2" ENF. TRANS.: SI ENF. MOTOR: NO</p> <p>TOMAS: ENTRADA: 1 3/4" SALIDA: 1 3/4"</p> <p>031</p>	<p>A1530-44P3 CHEVROLET/GMC</p>  <p>94-98 P3500 / 94-98 P30</p> <p>DPI 1530 V6 4.3 V8 5.7</p> <p>PANAL: 28 1/4" X 19 3/16" X 1 3/4" CAB. SUP.: 3 3/16" X 20 3/4" CAB. INF.: 3 3/16" X 20 3/4" ENF. TRANS.: SI ENF. MOTOR: NO TOC: 101051 / EOC: 1016475</p> <p>TOMAS: ENTRADA: 1 5/16" SALIDA: 1 9/16"</p> <p>032</p>	<p>A1531-28C CHEVROLET/GMC</p>  <p>Entrada 15/16</p> <p>S-10/S-15/SONOMA 94-97</p> <p>6004 PHAR / DPI 1531 L4 2.2</p> <p>PANAL: 23 5/8" X 15" X 1 1/8" CAB. SUP.: 2 1/2" X 16 5/8" CAB. INF.: 2 1/2" X 16 5/8" ENF. TRANS.: SI ENF. MOTOR: NO</p> <p>TOMAS: ENTRADA: 1 5/16" SALIDA: 1 5/16"</p> <p>033</p>
<p>A1533-28P3 CHEVROLET/GMC</p>  <p>Sin montajes usar A0705-28P3</p> <p>Con montajes</p> <p>BLAZER/S10/JIMMY/SONOMA 94-95</p> <p>V6 4.3</p> <p>PANAL: 26 1/4" X 15 3/16" X 1 1/8" CAB. SUP.: 2 1/4" X 16 3/8" CAB. INF.: 2 1/4" X 16 3/8" ENF. TRANS.: SI ENF. MOTOR: SI</p> <p>TOMAS: ENTRADA: 1 5/16" SALIDA: 1 9/16"</p> <p>034</p>	<p>A1610-28C CHEVROLET</p>  <p>Enfriador lado copiloto</p> <p>Montaje para condensador en parte trasera Toma inferior 90°</p> <p>CORSICA 94-95/BERETTA 94-95</p> <p>L4 2.2 / V6 3.1</p> <p>PANAL: 33 1/8" X 16 5/8" X 5 3/4" CAB. SUP.: 16 7/16" X 2 5/16" CAB. INF.: 16 7/16" X 2 5/16" EDA: SI CONCENTRICO</p> <p>TOMAS: ENTRADA: 1 1/4" SALIDA: 1 1/4"</p> <p>035</p>	<p>A1687-28C CHEVROLET/GMC/PONTIAC</p>  <p>SUNFIRE/CAVALIER 95-03</p> <p>1687 DPI / 2207 PHAR L4 2.2/2.3/2.4</p> <p>PANAL: 25 7/8" X 15" X 1 1/8" CAB. SUP.: 2 1/2" X 16 5/8" CAB. INF.: 2 1/2" X 16 5/8" ENF. TRANS.: SI 756597 ENF. MOTOR: NO</p> <p>TOMAS: ENTRADA: 1 5/16" SALIDA: 1 5/16"</p> <p>036</p>

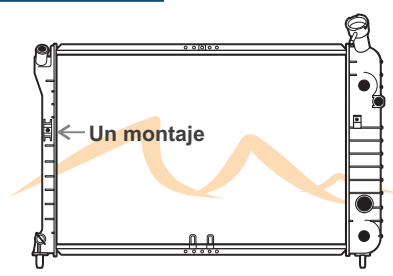
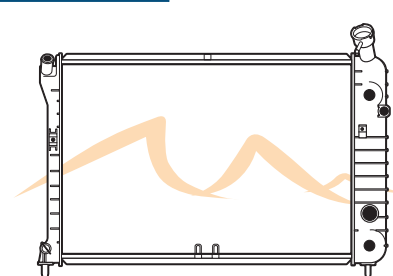
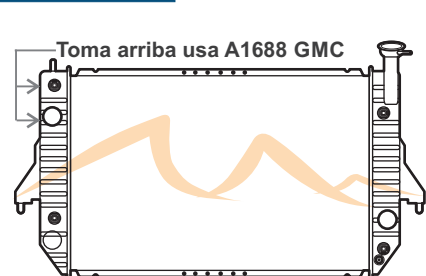
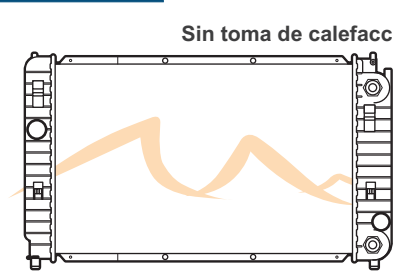
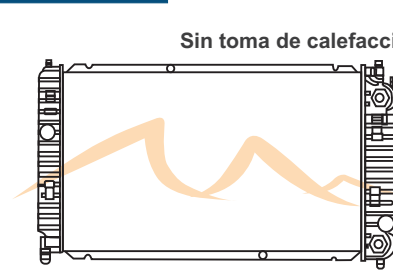
<p>A1687-28N CHEVROLET/GMC/PONTIAC</p>  <p>SUNFIRE/CAVALIER 95-03</p> <p>DPI 1687 / 2207 PHAR</p> <p>PANAL: 25 7/8" X 15" X 1 1/8" CAB. SUP.: 2 1/2" X 16 5/8" CAB. INF.: 2 1/2" X 16 5/8" ENF. TRANS.: NO ENF. MOTOR: NO</p> <p>TOMAS: ENTRADA: 1 5/16" SALIDA: 1 5/16"</p> <p>037</p>	<p>A1688-28P3 CHEVROLET/GMC</p>  <p>ASTRO/SAFARI 95-02</p> <p>DPI 1688 / 7003 PHAR V6 4.3</p> <p>PANAL: 28 1/4" X 17 1/4" X 1 1/8" CAB. SUP.: 2 1/2" X 18 3/4" CAB. INF.: 2 1/2" X 18 3/4" ENF. TRANS.: SI 3 PLACAS 1016475 ENF. MOTOR 3 PLACAS</p> <p>TOMAS: ENTRADA: 1 5/16" SALIDA: 1 9/16"</p> <p>038</p>	<p>A1693-44P3 CHEVROLET/GMC</p>  <p>SUBURBAN/SERIES PICK UP 94-99/94-00</p> <p>6033 PHAR V8 5.0/5.7</p> <p>PANAL: 34" X 17 1/4" X 1 3/4" CAB. SUP.: 3 1/4" X 18 1/2" CAB. INF.: 3 1/4" X 18 1/2" ENF. TRANS.: SI ENF. MOTOR: SI</p> <p>TOMAS: ENTRADA: 1 5/16" SALIDA: 1 9/16"</p> <p>039</p>
<p>A1694-44P3 CHEVROLET</p>  <p>SERIES PICK UP/CHEYENNE/SILVERADO/SIERRA 88-99</p> <p>DPI 1694 / 6033 PHAR V8 5.0/5.7</p> <p>PANAL: 34" X 17 1/4" X 1 3/4" CAB. SUP.: 18 7/16" X 3 3/16" CAB. INF.: 18 7/16" X 3 3/16" ENF. TRANS.: SI ENF. MOTOR: NO</p> <p>TOMAS: ENTRADA: 1 1/2" SALIDA: 1 1/4"</p> <p>040</p>	<p>A1694-60P3 CHEVROLET</p>  <p>88-99 SERIES PICK UP CHEYENNE/SILVERADO/SIERRA</p> <p>DPI 1694 / 6033 PHAR V8 5.0</p> <p>PANAL: 34" X 17 1/4" X 2 3/8" CAB. SUP.: 18 7/16" X 3 3/16" CAB. INF.: 18 7/16" X 3 3/16" ENF. TRANS.: SI ENF. MOTOR: NO</p> <p>TOMAS: ENTRADA: 1 1/2" SALIDA: 1 1/4"</p> <p>041</p>	<p>A1696-44P3 CHEVROLET/GMC</p>  <p>C/K SERIES 94-00/SUBURBAN/HEAVY DUTY 95-97</p> <p>PHAR 2509 / DPI 1696 V8 7.4</p> <p>PANAL: 34" X 19 3/16" X 1 3/4" CAB. SUP.: 20 11/16" X 3 3/16" CAB. INF.: 20 11/16" X 3 3/16" ENF. TRANS.: SI ENF. MOTOR: NO</p> <p>TOMAS: ENTRADA: 1 1/4" SALIDA: 1 1/2"</p> <p>042</p>
<p>A1825-28P3 CHEVROLET/GM</p>  <p>JIMMY/PICK UP/BRAVADA /S-10/BLAZER/PICK UP 96-05</p> <p>2608 PHAR V6 4.3</p> <p>PANAL: 26 1/4" X 15" X 1 1/8" CAB. SUP.: 2 1/2" X 16 5/8" CAB. INF.: 2 1/2" X 16 5/8" ENF. TRANS.: NO ENF. MOTOR: SI 3 PLACAS</p> <p>TOMAS: ENTRADA: 1 5/16" SALIDA: 1 9/16"</p> <p>043</p>	<p>A1826-28P3 CHEVROLET/GMC</p>  <p>S/T PICK UP BLAZER S-10/JIMMY 96-05</p> <p>DPI 1826 / 2607 PHAR V8 4.6</p> <p>PANAL: 26 1/4" X 15" X 1 1/8" CS: 2 1/2" X 16 5/8" CI: 2 1/2" X 16 5/8" ENF. TRANS.: SI ENF. MOTOR: SI</p> <p>TOMAS: ENTRADA: 1 1/4" SALIDA: 1 1/2"</p> <p>044</p>	<p>A1885-28C CHEVROLET/GMC</p>  <p>CORVETTE 97-04</p> <p>1885 DPI V8 5.7</p> <p>PANAL: 24 3/4" X 18 1/2" X 1 1/8" CAB. SUP.: 2 7/16" X 18 11/16" CAB. INF.: 2 7/16" X 18 11/16" ENF. TRANS.: SI ENF. MOTOR: NO</p> <p>TOMAS: ENTRADA: 1 1/4" SALIDA: 1 1/4"</p> <p>045</p>

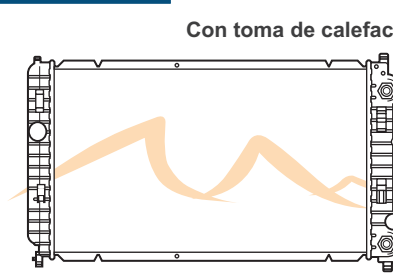
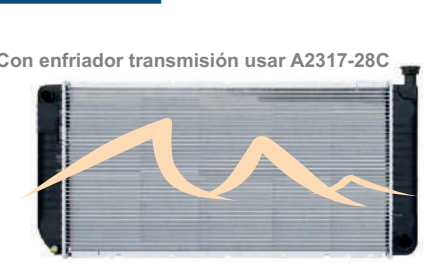
<p>A1888-28P3 CHEVROLET/GMC/ OLDSMOBILE/PONTIAC</p>  <p>GRAND PRIX/VENTURE/SILHOUETTE 97-03</p> <p>DPI 1888 / 6109 PHAR V6 3.8</p> <p>PANAL: 30 1/2" X 15 5/16" X 1 1/8" CAB. SUP.: 2 7/16" X 16 9/16" CAB. INF.: 2 7/16" X 16 9/16" ENF. TRANS.: SI ENF. MOTOR: SI</p> <p>TOMAS: ENTRADA: 1 5/16" SALIDA: 1 5/16"</p> <p>046</p>	<p>A1889-13P3 CHEVROLET/GMC/ OLDSMOBILE/PONTIAC</p>  <p>GRAND PRIX/TRANSPORT/VENTURE/SILHOUETTE 97-03</p> <p>DPI 1889 / 6109 PHAR V6 3.8</p> <p>PANAL: 30 1/2" X 14 7/8" X 1 1/2" CAB. SUP.: 2 7/16" X 16 9/16" CAB. INF.: 2 7/16" X 16 9/16" ENF. TRANS.: SI ENF. MOTOR: NO</p> <p>TOMAS: ENTRADA: 1 5/16" SALIDA: 1 5/16"</p> <p>047</p>	<p>A2003-28P3 CHEVROLET/GM</p>  <p>ASTRO / SAFARI VAN 98-05</p> <p>DPI 1786 / 7039 PHAR V6 4.3</p> <p>PANAL: 28 1/4" X 17 1/2" X 1 1/8" CAB. SUP.: 2 5/16" X 18 5/8" CAB. INF.: 2 5/16" X 18 5/8" ENF. TRANS.: SI ENF. MOTOR: SI</p> <p>TOMAS: ENTRADA: 1 5/16" SALIDA: 1 9/16"</p> <p>048</p>
<p>A2039-13P3 CHEVROLET/GM</p>  <p>MALIBU 97-98</p> <p>DPI 2039 / 6112 PHAR L4 2.4 / V6 3.1</p> <p>PANAL: 25 7/8" X 14 7/16" X 1 1/4" CAB. SUP.: 2 1/16" X 15 1/2" CAB. INF.: 2 1/16" X 15 1/2" ENF. TRANS.: SI 3 PLACAS ENF. MOTOR: NO</p> <p>TOMAS: ENTRADA: 1 5/16" SALIDA: 1 5/16"</p> <p>049</p>	<p>A2039-28C CHEVROLET/GM</p>  <p>MALIBU 97-03</p> <p>DPI 2039 / 6112 PHAR L4 2.1 / V6 3.1</p> <p>PANAL: 24" X 14 7/16" X 1 1/8" CAB. SUP.: 2 1/16" X 15 1/2" CAB. INF.: 2 1/16" X 15 1/2" ENF. TRANS.: SI ENF. MOTOR: NO</p> <p>TOMAS: ENTRADA: 1 3/8" SALIDA: 1 3/8"</p> <p>050</p>	<p>A2110-44N CHEVROLET</p>  <p>KODIAK 97-02 / TOPKICK 97-02</p> <p>6235 PHAR V8 7.0/7.4/6.0</p> <p>PANAL: 31 9/16" X 23 3/16" CAB. SUP.: 3" X 24 9/16" CAB. INF.: 3" X 24 9/16" ENF. TRANS.: NO ENF. MOTOR: NO</p> <p>TOMAS: ENTRADA: 2" SALIDA: 2"</p> <p>051</p>
<p>A2251-28C CHEVROLET/PONTIAC/ OLDSMOBILE</p>  <p>LUMINIA 96-01/CUTLASS SUPREME/ GRAND PRIX 1996 / MONTE CARLO 96-99</p> <p>V6 3.1/3.4/3.8</p> <p>PANAL: 30 7/16" X 15 3/16" X 1 1/8" CAB. SUP.: 2 7/16" X 16 3/8" CAB. INF.: 2 7/16" X 16 3/8" ENF. TRANS.: SI ENF. MOTOR: NO</p> <p>TOMAS: ENTRADA: 1 5/16" SALIDA: 1 5/16"</p> <p>052</p>	<p>A2264-13C CHEVROLET/GM/PONTIAC</p>  <p>GRAND AM 99-05/MALIBU 97-03</p> <p>DPI 2264 / 6018 PHAR L4 2.4 / V6 3.1/3.4</p> <p>PANAL: 25 7/8" X 14 7/16" X 1/2" CAB. SUP.: 2 1/16" X 15 1/2" CAB. INF.: 2 1/16" X 15 1/2" ENF. TRANS.: SI 3 PLACAS ENF. MOTOR: NO</p> <p>TOMAS: ENTRADA: 1 5/16" SALIDA: 1 5/16"</p> <p>053</p>	<p>A2316-28N CHEVROLET/GMC</p>  <p>SERIES PICK UP/CHEYENNE/SILVERADO 96-04 SIERRA / C/K SERIES 96-99</p> <p>1734 PHAR / DPI 2316 V8 5.0/5.7</p> <p>PANAL: 34" X 17 3/8" X 1 1/8" CAB. SUP.: 18 3/8" X 3 1/8" CAB. INF.: 18 3/8" X 3 1/8" ENF. TRANS.: NO ENF. MOTOR: NO</p> <p>TOMAS: ENTRADA: 1 9/16" SALIDA: 1 5/16"</p> <p>054</p>

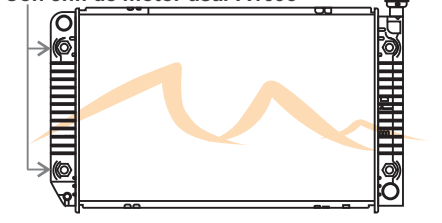
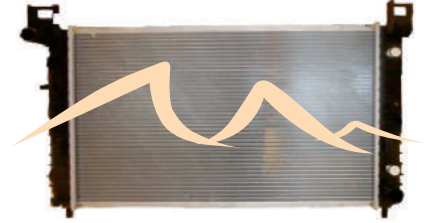
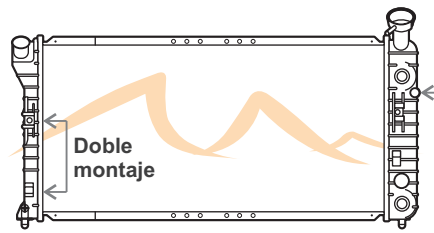
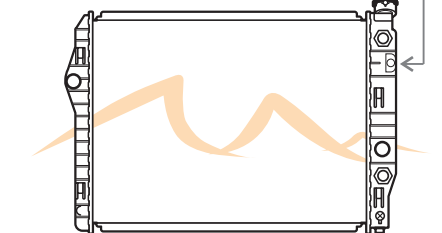
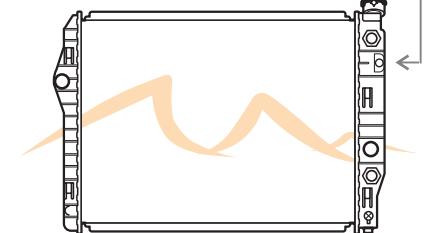
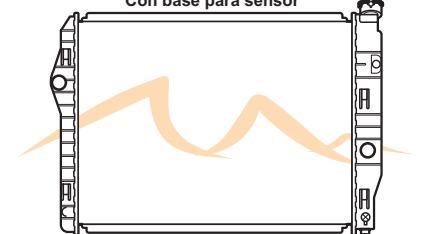
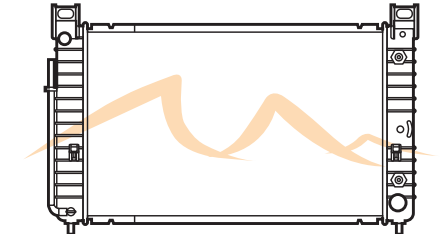
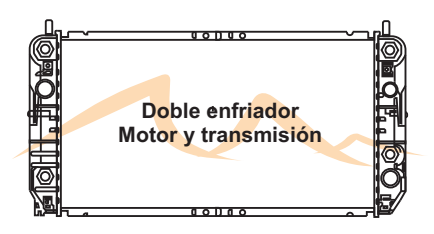
<p>A2317-28C CHEVROLET/GMC/CADILLAC</p> <p>Sin enfriador usar A2316-28N</p>  <p>SERIES PICK UP/CHEYENNE/SILVERADO 96-04 SIERRA/YUKON 96-99/ESCALADE 99-00</p> <p>V8 5.0/5.7</p> <p>PANAL: 34" X 17 3/8" X 1 1/8" CAB. SUP.: 18 3/8" X 3 1/8" CAB. INF.: 18 3/8" X 3 1/8" ENF. TRANS.: SI 756597-M ENF. MOTOR: NO 02/15</p> <p>TOMAS: ENTRADA: 1 5/16" SALIDA: 1 9/16"</p> <p>055</p>	<p>A2317-44P3 CHEVROLET/GMC</p> <p>Con enf. de motor usar A1693</p>  <p>YUKON/SUBURBAN/ESCALADE</p> <p>DPI 2317</p> <p>V8 4.6</p> <p>PANAL: 34" X 18 7/16" X 1 3/4" CAB. SUP.: 3" X 18 3/8" CAB. INF.: 3" X 18 3/8" ENF. TRANS.: SI ENF. MOTOR: NO</p> <p>TOMAS: ENTRADA: 1 9/16" SALIDA: 1 3/8"</p> <p>056</p>	<p>A2334-28C CHEVROLET/CADILLAC</p>  <p>ESCALADE 05/SILVERADO 1500, 2500 99-13</p> <p>V6 4.3 V8 4.8/5.3/6.0/6.2</p> <p>PANAL: 28 9/16" X 17 1/4" X 1 1/8" CAB. SUP.: 18 3/4" X 2 7/16" CAB. INF.: 18 3/4" X 2 7/16" ENF. TRANS.: SI ENF. MOTOR: NO</p> <p>TOMAS: ENTRADA: 1 9/16" SALIDA: 1 5/16"</p> <p>CONDENSADOR: AC3026/AC4953</p> <p>057</p>
<p>A2351-28P4 CHEVROLET/GMC/BUICK</p>  <p>Doble montaje</p> <p>Base sensor de motor</p> <p>REGAL 00-04 / IMPALA 00-03</p> <p>DPI 6219 / 6219 PHAR</p> <p>V6 3.4/3.8</p> <p>PANAL: 30 1/2" X 15 5/16" X 1 1/8" CAB. SUP.: 2 7/16" X 16 9/16" CAB. INF.: 2 7/16" X 16 9/16" ENF. TRANS.: SI ENF. MOTOR:</p> <p>TOMAS: ENTRADA: 1 5/16" SALIDA: 1 5/16"</p> <p>058</p>	<p>A2361-28C CHEVROLET/GM</p> <p>Sensor de temperatura</p>  <p>CAMARO 98-02</p> <p>DPI 2361</p> <p>V6 3.8</p> <p>PANAL: 24 13/16" X 17" X 1 1/8" CAB. SUP.: 2 7/16" X 18 3/4" CAB. INF.: 2 7/16" X 18 3/4" ENF. TRANS.: SI ENF. MOTOR: NO</p> <p>TOMAS: ENTRADA: 1 5/16" SALIDA: 1 5/16"</p> <p>059</p>	<p>A2365-28C CHEVROLET/GM/PONTIAC</p> <p>Sensor de temperatura</p>  <p>FIREBIRD 98-99/CAMARO 98-99</p> <p>DPI 2365</p> <p>V8 5.7</p> <p>PANAL: 24 13/16" X 17 1/2" X 1 1/8" CAB. SUP.: 2 7/16" X 18 3/4" CAB. INF.: 2 7/16" X 18 3/4" ENF. TRANS.: SI ENF. MOTOR: NO</p> <p>TOMAS: ENTRADA: 1 5/16" SALIDA: 1 5/16"</p> <p>060</p>
<p>A2365-28N CHEVROLET/GM/PONTIAC</p> <p>Con base para sensor</p>  <p>FIREBIRD/CAMARO 98-99</p> <p>DPI 2471</p> <p>V8 5.7</p> <p>PANAL: 24 13/16" X 17 1/2" X 1 1/8" CAB. SUP.: 2 7/16" X 18 3/4" CAB. INF.: 2 7/16" X 18 3/4" ENF. TRANS.: NO ENF. MOTOR: NO</p> <p>TOMAS: ENTRADA: 1 5/16" SALIDA: 1 5/16"</p> <p>061</p>	<p>A2368-28C CHEVROLET/GM</p>  <p>SILVERADO/SIERRA PICK UP 99-04</p> <p>DPI 2368 / 6008 PHAR</p> <p>V8 4.8/5.3</p> <p>PANAL: 28 1/4" X 17 1/2" X 1 1/8" (28 mm) CAB. SUP.: 2 3/8" X 18 11/16" CAB. INF.: 2 3/8" X 18 11/16" ENF. TRANS.: SI ENF. MOTOR: NO</p> <p>TOMAS: ENTRADA: 1 5/16" SALIDA: 1 9/16"</p> <p>062</p>	<p>A2369-28C CHEVROLET/GMC/CADILLAC</p> <p>Doble enfriador Motor y transmisión</p>  <p>DEVILLE 2000</p> <p>DPI 2369</p> <p>V8 4.6</p> <p>PANAL: 30 9/16" X 14 7/8" X 1 1/8" CAB. SUP.: 2 3/8" X 16 7/16" CAB. INF.: 2 3/8" X 16 7/16" ENF. TRANS.: SI TOC: 101050 EOC: 1016475 ENF. MOTOR: NO</p> <p>TOMAS: ENTRADA: 1 1/2" SALIDA: 1 3/8"</p> <p>063</p>

A2370-28P3 CHEVROLET/CADILLAC

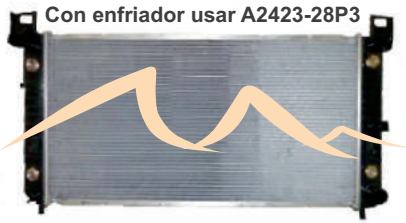

ESCALADE 02-13/SUBURBAN/SILVERADO
TAHOE 99-13/SIERRA/YUKON 99-13/HUMMER 09-13

DPI 2370 V8 5.3/6.0/6.2 V8 4.8/5.3/6.0

PANAL: 34" X 17 13/64" X 1 1/8"
CAB. SUP.: 3" X 18 1/4"
CAB. INF.: 3" X 18 1/4"
ENF. TRANS.: SI
ENF. MOTOR: SI
CONDENSADOR: AC3026/AC4953

TOMAS:
ENTRADA: 1 5/16"
SALIDA: 1 9/16"

064

A2420-28C CHEVROLET/GM

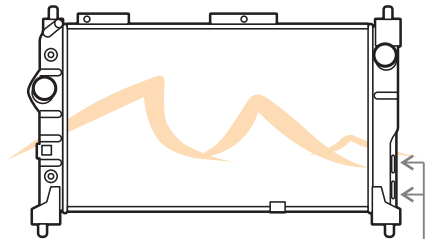

Base para bulbos

CHEVY MONZA/JOY/PICK UP C/A 94-03

2420 PHAR 1.2/1.4/1.6

PANAL: 26 7/8" X 10 15/16" X 1 1/8"
CAB. SUP.: 1 3/4" X 11 3/16"
CAB. INF.: 1 3/4" X 11 3/16"
ENF. TRANS.: SI
ENF. MOTOR: NO
NOTAS: C/BULBOS

TOMAS:
ENTRADA: 1 3/8"
SALIDA: 1 3/8"

065

A2420-28N CHEVROLET/GM

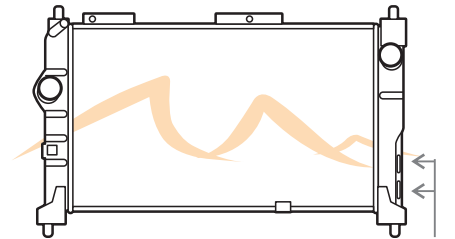

Base para bulbos

CHEVY MONZA/JOY/PICK UP C/A 94-03

2420 PHAR 1.2/1.4/1.6

PANAL: 26 7/8" X 10 15/16" X 1 1/8"
CAB. SUP.: 1 3/4" X 11 3/16"
CAB. INF.: 1 3/4" X 11 3/16"
ENF. TRANS.: NO
ENF. MOTOR: NO
NOTAS: C/BULBOS

TOMAS:
ENTRADA: 1 3/8"
SALIDA: 1 3/8"

066

A2423-28C CHEVROLET/GM/CADILLAC

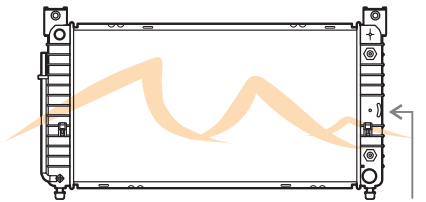

Toma calefacción

SILVERADO/ESCALADE 02-13/SIERRA/YUKON 99-07

DPI 2423 V8 4.8/5.3/6.0/6.2

PANAL: 34" X 17 1/2" X 1 1/8"
CAB. SUP.: 2 5/16" X 18 9/16"
CAB. INF.: 2 5/16" X 18 9/16"
ENF. TRANS.: SI
ENF. MOTOR: NO
CONDENSADOR: AC3026/AC4953

TOMAS:
ENTRADA: 1 5/16"
SALIDA: 1 5/16"

067

A2423-28N CHEVROLET/GM/CADILLAC



Toma calefacción

SILVERADO/ESCALADE 02-13/
SIERRA/YUKON 99-07

6013 PHAR V8 4.8/5.3/6.0/6.2

PANAL: 34" X 17 1/2" X 1 1/8"
CAB. SUP.: 3 3/16" X 18 5/8"
CAB. INF.: 3 3/16" X 18 5/8"
ENF. TRANS.: SI
ENF. MOTOR: NO
CONDENSADOR: AC3026/AC4953

TOMAS:
ENTRADA: 1 5/16"
SALIDA: 1 9/16"

068

A2458-28P4 CHEVROLET/GM

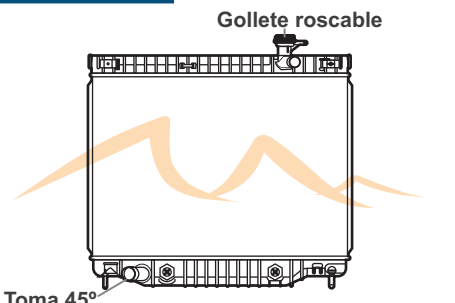

Gollete roscable

Toma 45°

ENVOY/TRAIL BLAZER 02-09

DPI 2458 / 7027 PHAR L6 4.2

PANAL: 18" X 26 1/2" X 1 1/8"
CAB. SUP.: 2 3/8" X 27 9/16"
CAB. INF.: 2 3/8" X 27 9/16"
ENF. TRANS.: 11 1/2" 4 PLACAS
ENF. MOTOR: NO

TOMAS:
ENTRADA: 1 5/16"
SALIDA: 1 9/16"

069

A2518-28C CHEVROLET/GMC

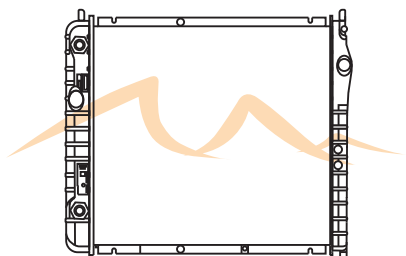

CAVALIER/SUNFIRE 02-05

DPI 2518 / 6107 PHAR L4 2.2/2.4

PANAL: 26" X 15 3/16" X 1 1/8"
CAB. SUP.: 2 5/16" X 16 7/16"
CAB. INF.: 2 3/16" X 16 7/16"
ENF. TRANS.: SI
ENF. MOTOR: NO

TOMAS:
ENTRADA: 1 5/16"
SALIDA: 1 5/16"

070

A2551-44P3 CHEVROLET/GMC

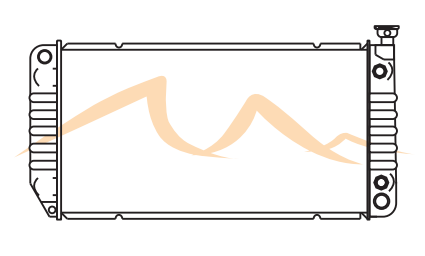

YUKON/SUBURBAN/ESCALADE 98-99

DPI 2551 / 1734 PHAR V8 5.7

PANAL: 34" X 18 7/16" X 1 3/4"
CAB. SUP.: 3" X 18 3/8"
CAB. INF.: 3" X 18 3/8"
ENF. TRANS.: SI
ENF. MOTOR: NO

TOMAS:
ENTRADA: 1 9/16"
SALIDA: 1 3/8"

071

A2707-28P3 CHEVROLET/GMC

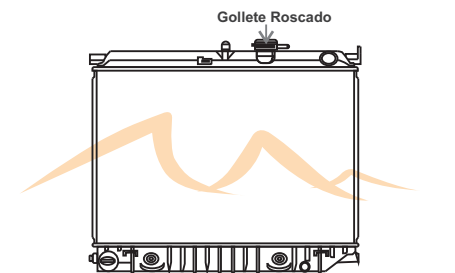

Gollete Roscado

CANYON 04-12 / COLORADO 04-10

2707 DPI L4 2.8/2.9 L5 3.5/3.7

PANAL: 18" X 24" X 1 1/8"
CAB. SUP.: 2 1/8" X 23 9/16"
CAB. INF.: 2 1/8" X 23 9/16"
ENF. TRANS.: SI
ENF. MOTOR: NO
CONDENSADOR: AC3014

TOMAS:
ENTRADA: 1 5/16"
SALIDA: 1 9/16"

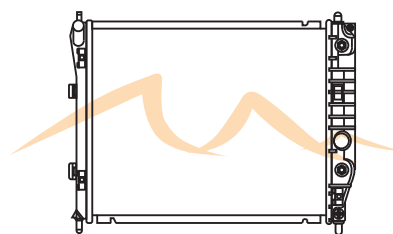
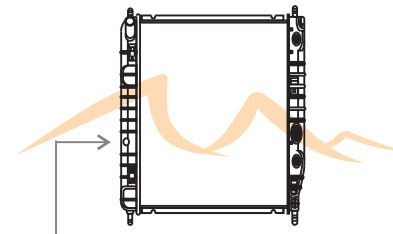
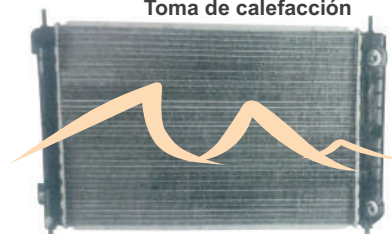
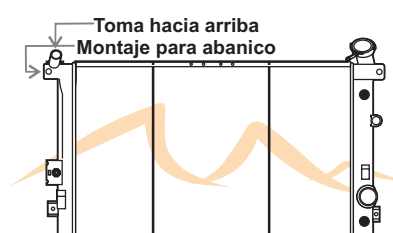
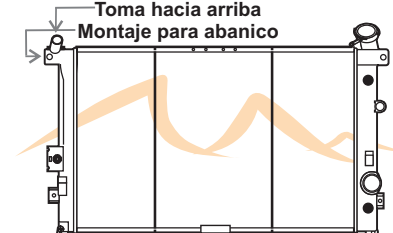
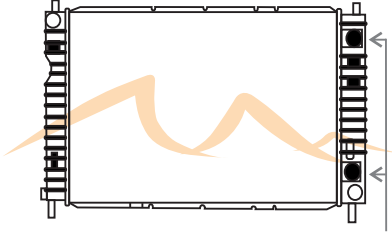
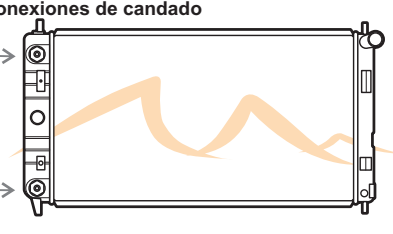
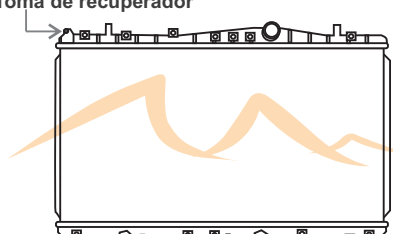
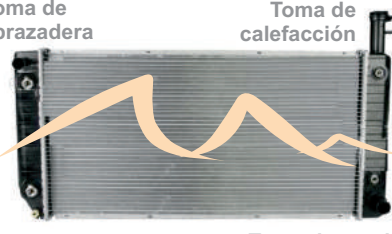

072

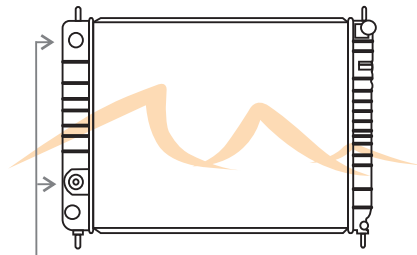
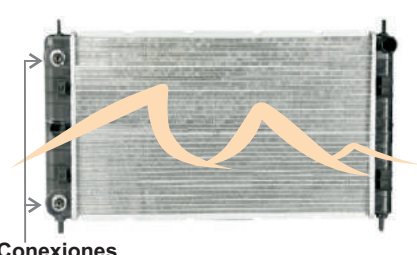
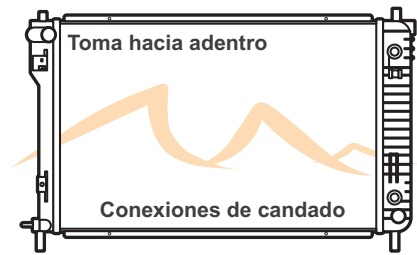
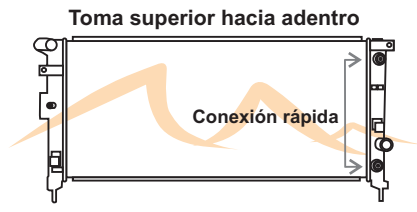
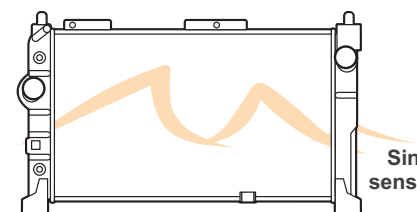
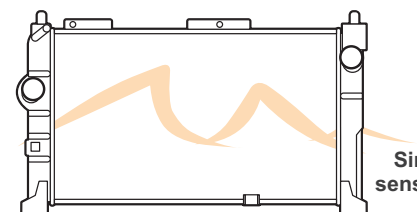
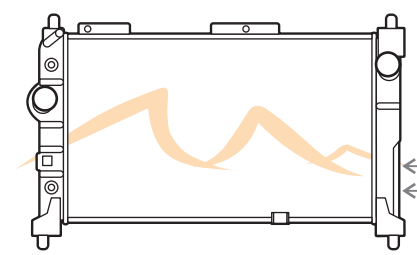
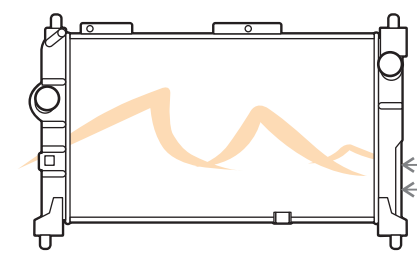
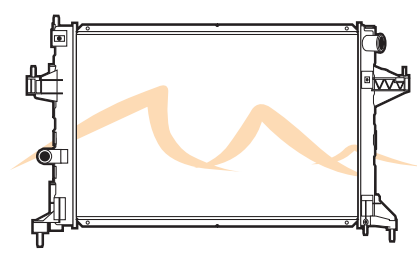
<p>A2714-28P3 CHEVROLET/GMC</p>  <p>SSR 03-06/CORVETTE 03-13</p> <p>DPI 2714 V8 5.3/6.0/6.2/7.0</p> <p>PANAL: 23 1/2" X 18 1/2" X 1 1/8" CAB. SUP.: 2 5/16" X 18 1/2" CAB. INF.: 2 5/16" X 18 1/2" ENF. TRANS.: SI 3 PLACAS ENF. MOTOR: NO</p> <p>TOMAS: ENTRADA: 1 3/8" SALIDA: 1 3/8"</p> <p>073</p>	<p>A2715-28P3 CHEVROLET/GMC/CADILLAC</p>  <p>CADILLAC XLR 04-09</p> <p>DPI 2715 V8 4.4/4.6</p> <p>PANAL: 23 1/2" X 18 1/2" X 1 1/8" CS: 2 5/16" X 18 9/16" CI: 2 5/16" X 18 9/16"</p> <p>ENFRIADOR: SI 3 PLACAS</p> <p>ENTRADA: 1 3/8" SALIDA: 1 3/8"</p> <p>074</p>	<p>A2727-28P3 CHEVROLET/PONTIAC/SATURN</p>  <p>MALIBU/G6/AURA 04-10</p> <p>DPI 2715 V6 3.5/3.9</p> <p>PANAL: 26 3/4" X 14 1/16" X 1 1/8" CAB. SUP.: 14 15/16" X 1 7/8" CAB. INF.: 14 15/16" X 1 7/8" ENF. TRANS.: 11 1/2"</p> <p>TOMAS: ENTRADA: 1 5/16" SALIDA: 1 5/16"</p> <p>CONDENSADOR: AC3279</p> <p>075</p>
<p>A2728-13C CHEVROLET/GMC/PONTIAC/BUICK</p>  <p>AZTEK/VENTURE/RENDEZ/IMPALA 03-05</p> <p>DPI 2728 / 7033 PHAR V6 3.4/3.5</p> <p>PANAL: 30 1/2" X 15" X 1 1/8" CS: 2 1/2" X 15 3/8" CI: 2 1/2" X 15 3/8"</p> <p>ENTRADA: 1 5/16" SALIDA: 1 5/16"</p> <p>ENFRIADOR: SI CONDENSADOR: AC3050</p> <p>076</p>	<p>A2728-28C CHEVROLET/GMC/PONTIAC/BUICK</p>  <p>AZTEK/VENTURE/RENDEZ/IMPALA 03-05</p> <p>DPI 2728 / 7033 PHAR V6 3.4/3.5</p> <p>PANAL: 30 1/2" X 15" X 1 1/8" CS: 2 1/2" X 15 3/8" CI: 2 1/2" X 15 3/8"</p> <p>ENTRADA: 1 5/16" SALIDA: 1 5/16"</p> <p>ENFRIADOR: SI CONDENSADOR: AC3050</p> <p>077</p>	<p>A2764-28C CHEVROLET/GM</p>  <p>EQUINOX 05</p> <p>DPI 2764 V6 3.4</p> <p>PANAL: 25 8/9" X 17 3/4" X 1 1/8" CS: 1 13/16" X 17 1/8" CI: 3 1/16" X 17 1/8"</p> <p>ENTRADA: 1 1/4" SALIDA: 1 1/4"</p> <p>ENFRIADOR: SI</p> <p>078</p>
<p>A2765-13C CHEVROLET/GMC</p>  <p>MALIBU 04-08</p> <p>DPI 2765 / 7031 PHAR L4 2.2</p> <p>PANAL: 26 3/4" X 15 1/2" X 1/2" CS: 1 7/8" X 14 7/8" CI: 1 7/8" X 14 15/16"</p> <p>ENTRADA: 1 3/8" SALIDA: 1 3/8"</p> <p>ENFRIADOR: SI CONDENSADOR: AC3279</p> <p>079</p>	<p>A2788-13C CHEVROLET/GMC/SUZUKI</p>  <p>RENO/FORENZA 04-08/OPTRA 04-10</p> <p>DPI 2765 / 7031 PHAR L4 2.0</p> <p>PANAL: 14 7/8" X 28 5/8" X 1/2" CS: 1 13/16" X 28 3/16" CI: 2" X 28 3/16"</p> <p>ENTRADA: 1 3/8" SALIDA: 1 3/8"</p> <p>EDA: SI EDAM: NO</p> <p>080</p>	<p>A2791-44P3 CHEVROLET/GMC</p>  <p>EXPRESS /SAVANA 04-14</p> <p>DPI 2791 V8 4.8/6.0</p> <p>PANAL: 34" X 17 1/16" X 1 3/4" CS: 3 3/16" X 18 5/8" CI: 3 3/16" X 18 5/8"</p> <p>ENTRADA: 1 5/16" SALIDA: 1 9/16"</p> <p>ENFRIADOR: SI Doble</p> <p>081</p>

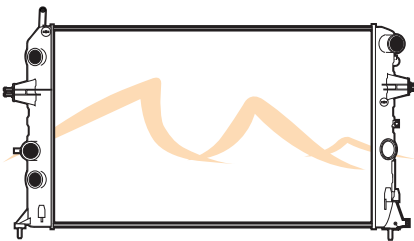
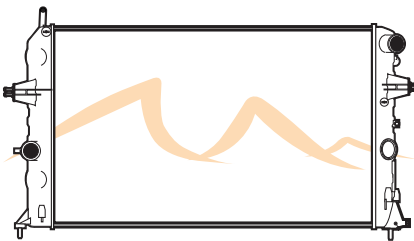
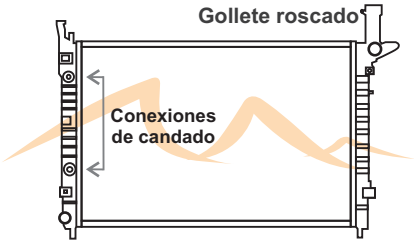
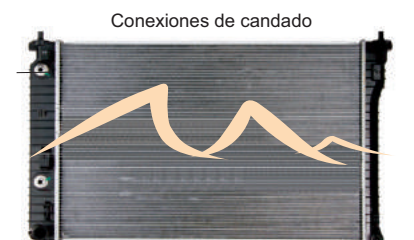
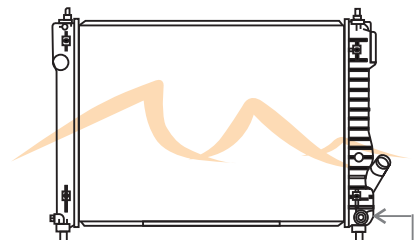
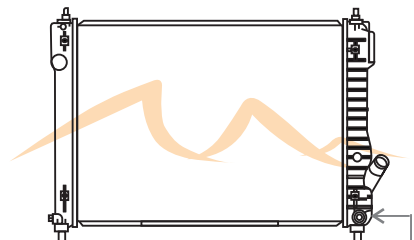
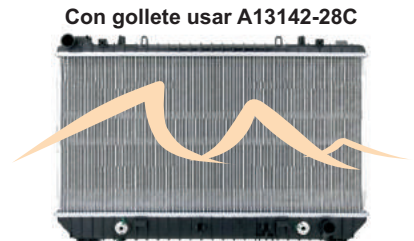
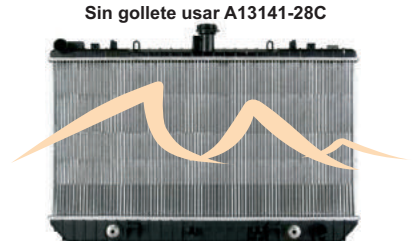
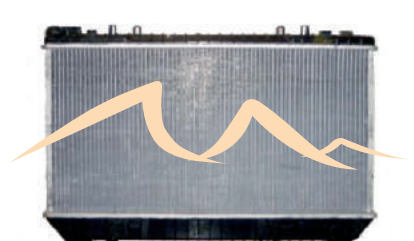
<p>A2850-28P3 CHEVROLET/GMC</p>  <p>Conexiones de candado</p> <p>HHR 06-11</p> <p>DPI 2850 L4 2.0/2.2/2.4</p> <p>PANAL: 21 5/8" X 17 4/5" X 1 1/8" CS: 1 7/8" X 17 1/2" ENTRADA: 1 5/16" CI: 1 7/8" X 17 1/2" SALIDA: 1 5/16"</p> <p>ENFRIADOR: SI 3 PLACAS</p> <p>082</p>	<p>A2864-28C CHEVROLET/PONTIAC/SATURN</p>  <p>Conexiones de candado</p> <p>MALIBU 08-12/ G6 06-10/AURA 07-09</p> <p>DPI 2864 L4 2.4/ V6 3.6</p> <p>PANAL: 26 3/4" X 14 5/8" X 1 1/8" CAB. SUP.: 14 7/8" X 1 7/8" CAB. INF.: 14 7/8" X 1 7/8"</p> <p>ENFRIADOR: SI CONDENSADOR: AC3279</p> <p>083</p>	<p>A2879-28C CHEVROLET/GMC/PONTIAC</p>  <p>Toma hacia adentro</p> <p>Conexiones de candado</p> <p>EQUINOX 06-09 /TORRENT 06-09</p> <p>DPI 2879 V6 3.4</p> <p>PANAL: 26" X 16 1/4" X 1 1/8" CS: 2 3/8" X 17 1/8" ENTRADA: 1 5/16" CI: 2 3/8" X 17 1/8" SALIDA: 1 5/16"</p> <p>EDA: SI</p> <p>084</p>
<p>A2881-28C CHEVROLET/GMC/PONTIAC/BUICK</p>  <p>Toma superior hacia adentro</p> <p>Conexión rápida</p> <p>TERRAZA 06-07/MONTANA/UPLANDER 06-09</p> <p>2881 PHAR V6 3.9</p> <p>PANAL: 30 1/2" X 15" X 1 1/8" CS: 2 1/2" X 15 3/8" ENTRADA: 1 1/4" CI: 2 1/2" X 15 3/8" SALIDA: 1 1/4"</p> <p>ENFRIADOR: SI</p> <p>085</p>	<p>A6039-13C CHEVROLET/GMC</p>  <p>Sin sensor</p> <p>CHEVY C2/CONFORT/MONZA 98-04</p> <p>6039 PHAR 1.4/1.6</p> <p>PANAL: 26 7/8" X 10 15/16" X 1/2" CS: 1 3/4" X 11 1/4" ENTRADA: 1 3/8" CI: 1 3/4" X 11 1/4" SALIDA: 1 3/8"</p> <p>ENFRIADOR: SI</p> <p>086</p>	<p>A6039-13N CHEVROLET/GMC</p>  <p>Sin sensor</p> <p>CHEVY C2/CONFORT/MONZA 98-04</p> <p>6039 PHAR 1.4/1.6</p> <p>PANAL: 26 7/8" X 10 15/16" X 1/2" CS: 1 3/4" X 11 1/4" ENTRADA: 1 3/8" CI: 1 3/4" X 11 1/4" SALIDA: 1 3/8"</p> <p>ENFRIADOR: NO</p> <p>087</p>
<p>A6039-28C CHEVROLET/GMC</p>  <p>Sin sensores</p> <p>CHEVY C2/CONFORT/MONZA 98-04</p> <p>6039 PHAR 1.4/1.6</p> <p>PANAL: 26 7/8" X 10 15/16" X 1 1/8" CS: 1 3/4" X 11 1/4" ENTRADA: 1 3/4" CI: 1 3/4" X 11 1/4" SALIDA: 1 3/4"</p> <p>ENFRIADOR: SI</p> <p>088</p>	<p>A6039-28N CHEVROLET/GMC</p>  <p>Sin sensores</p> <p>CHEVY C2/CONFORT/MONZA 98-04</p> <p>6039 PHAR 1.4/1.6</p> <p>PANAL: 26 7/8" X 10 15/16" X 1/2" CS: 1 3/4" X 11 1/4" ENTRADA: 1 3/8" CI: 1 3/4" X 11 1/4" SALIDA: 1 3/8"</p> <p>ENFRIADOR: NO</p> <p>089</p>	<p>A7023-13N CHEVROLET/GMC</p>  <p>Sin sensores</p> <p>CORSA/TORNADO 04-06</p> <p>7023 PHAR 1.8 16V</p> <p>PANAL: 21 1/4" X 13 49/64" X 1/2" CS: 1 5/8" X 15 3/8" ENTRADA: 1 3/8" CI: 1 5/8" X 15 3/8" SALIDA: 1 3/8"</p> <p>ENFRIADOR: NO</p> <p>090</p>

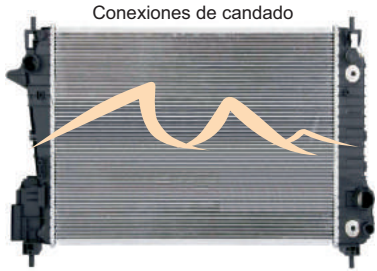
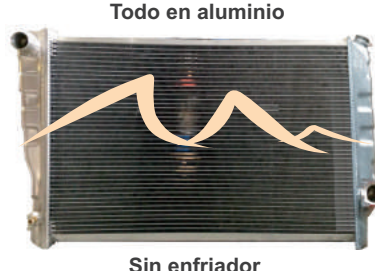
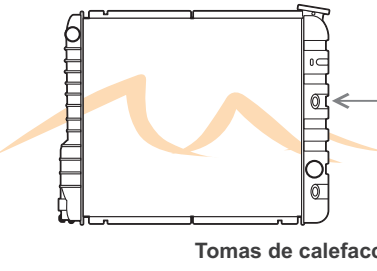
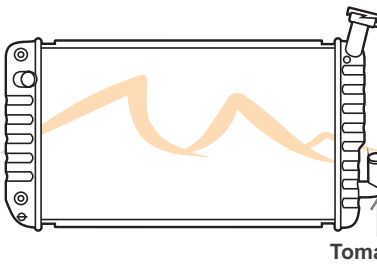
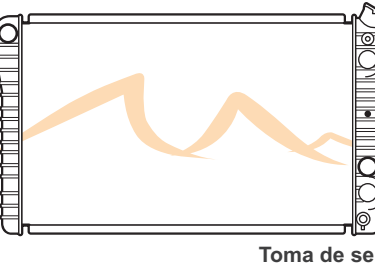
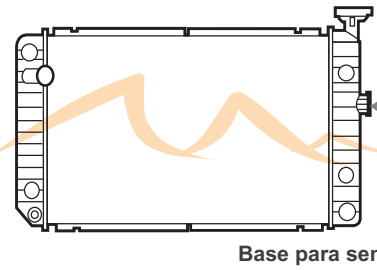
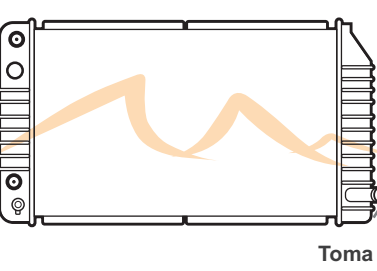
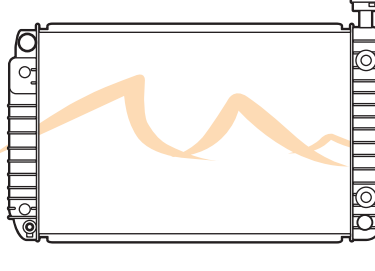
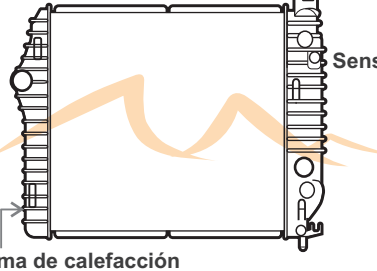
<p>A7024-28C CHEVROLET/GMC</p>  <p>ASTRA 02-08</p> <p>7024 PHAR 2.0/2.2 16V</p> <p>PANAL: 23 5/8" X 14 1/8" X 1 1/8" CS: 2 1/4" X 15 9/16" CI: 2 1/4" X 15 9/16"</p> <p>ENTRADA: 1 3/8" SALIDA: 1 3/8"</p> <p>ENFRIADOR: SI 757020</p> <p>091</p>	<p>A7024-28N CHEVROLET/GMC</p>  <p>ASTRA 04-08</p> <p>7024 PHAR 2.0/2.2 16V</p> <p>PANAL: 23 5/8" X 14 1/8" X 1 1/8" CS: 2 1/4" X 15 9/16" CI: 2 1/4" X 15 9/16"</p> <p>ENTRADA: 1 3/8" SALIDA: 1 3/8"</p> <p>ENFRIADOR: NO</p> <p>092</p>	<p>A13007-28C CHEVROLET/GMC/BUICK/SATURN</p>  <p>ENCLAVE 08-13 / TRAVERSE 09-13 / ACADIA 07-13 / OUTLOOK 07-10</p> <p>DPI 13007 V6 3.6</p> <p>PANAL: 27 1/2" X 18 3/4" X 1 1/8" CS: 2 5/16" X 19 15/16" CI: 2 5/16" X 19 15/16"</p> <p>ENTRADA: 1 5/16" SALIDA: 1 5/16"</p> <p>ENFRIADOR: SI CONDENSADOR: AC3649</p> <p>093</p>
<p>A13057-28C CHEVROLET/SATURN</p>  <p>CAPTIVA 08-16/VUE 08-10</p> <p>L4 2.4/ V6 3.0/3.5/3.6</p> <p>DPI 13097 L4 1.6</p> <p>PANAL: 26 3/8" X 19 3/4" X 1 1/8" CS: 2 1/2" X 20 3/4" CI: 2 1/2" X 20 3/4" EDA: SI</p> <p>ENTRADA: 1 5/16" SALIDA: 1 5/16"</p> <p>ENFRIADOR: SI</p> <p>094</p>	<p>A13097-28C CHEVROLET/GMC/PONTIAC/SUZUKI</p>  <p>SWIFT 2009/AVEO 09-13/G3 09-10</p> <p>DPI 13097 L4 1.6</p> <p>PANAL: 23 1/2" X 16 3/8" X 1 1/8" CS: 1 13/16 X 17 1/4" CI: 1 13/16 X 17 1/4"</p> <p>ENTRADA: 1 5/16" SALIDA: 1 5/16"</p> <p>ENFRIADOR: SI</p> <p>095</p>	<p>A13097-28N CHEVROLET/GMC/PONTIAC/SUZUKI</p>  <p>SWIFT 2009/AVEO 09-13/G3 09-10</p> <p>DPI 13097 L4 1.6</p> <p>PANAL: 23 1/2" X 16 3/8" X 1 1/8" CS 1 13/16 X 17 1/4": CI: 1 13/16 X 17 1/4"</p> <p>ENTRADA: 1 5/16" SALIDA: 1 5/16"</p> <p>ENFRIADOR: NO</p> <p>096</p>
<p>A13141-28C CHEVROLET/GM</p>  <p>CAMARO 10-11</p> <p>DPI 13141 V6 3.6</p> <p>PANAL: 15 1/8" X 29 1/4" X 1 1/8" CS: 2 3/8" X 30 9/16" CI: 2 3/8" X 30 9/16"</p> <p>ENTRADA: 1 3/8" SALIDA: 1 3/8"</p> <p>EDA: SI EDAM: NO</p> <p>097</p>	<p>A13142-28C CHEVROLET/GM</p>  <p>CAMARO 10-11</p> <p>DPI 13142</p> <p>PANAL: 15 1/8" X 29 1/4" X 1 1/8" CS: 2 3/8" X 30 9/16" CI: 2 3/8" X 30 9/16"</p> <p>ENTRADA: 1 5/16" SALIDA: 1 5/16"</p> <p>EDA: SI EDAM: NO</p> <p>098</p>	<p>A13211-28N CHEVROLET/GM</p>  <p>CAMARO 10-11</p> <p>DPI 13211 V6 3.6</p> <p>PANAL: 15 1/8" X 29 1/4" X 1 1/8" CS: 2 3/8" X 30 9/16" CI: 2 3/8" X 30 9/16"</p> <p>ENTRADA: 1 3/8" SALIDA: 1 3/8"</p> <p>EDA: NO EDAM: NO</p> <p>099</p>

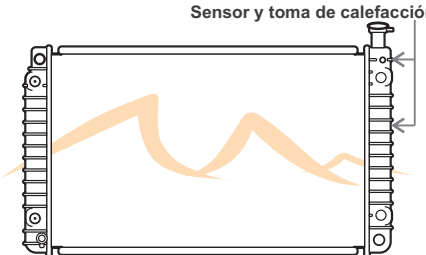
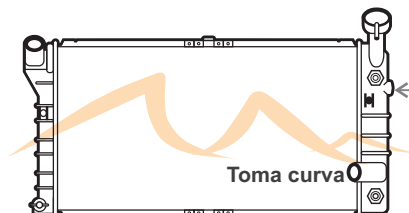
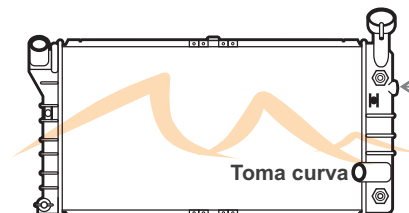
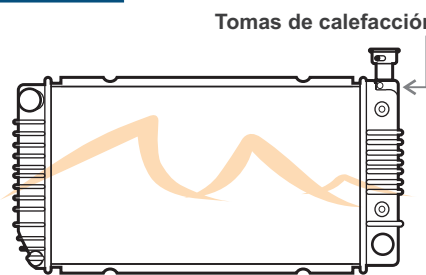
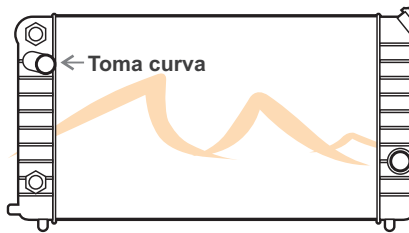
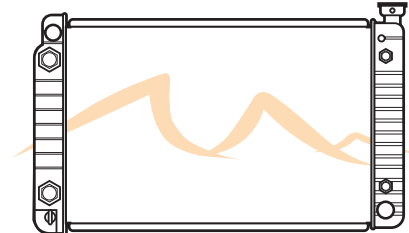
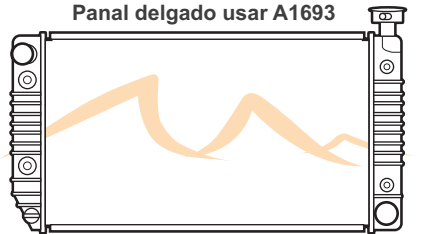
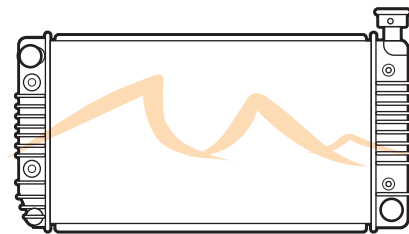
<p>A13248-13P3 CHEVROLET</p>  <p>Conexiones de candado</p> <p>SONIC 12-15 L4 1.4</p> <p>PANAL: 24 7/16" X 15 3/8" X 1/2" CS: 1 5/8" X 16 1/2" CI: 1 5/8" X 16 1/2" EDA: SI</p> <p>ENTRADA: 1 3/8" SALIDA: 1 1/2"</p> <p>100</p>	<p>AA0570-44N CHEVROLET</p>  <p>Todo en aluminio</p> <p>Sin enfriador</p> <p>NOVA/MALIBU 75-79 DPI 570 / 3707 PHAR V6 3.3/3.8 V8 4.4/5.0/5.7</p> <p>PANAL: 26 3/8" X 16 3/4" X 1 3/4" CAB. SUP.: 2 7/16" X 19" CAB. INF.: 2 7/16" X 19" ENFRIADOR: NO</p> <p>TOMAS: ENTRADA: 1 1/2" SALIDA: 1 1/2"</p> <p>101</p>	<p>0206 DPI CHEVROLET/GM</p>  <p>Tomas de calefacción</p> <p>3/T SERIES PICK UP/BLAZER 85-93/SONOMA/JIMMY DPI 206 L4 2.5</p> <p>PANAL: 23 5/8" X 15" X 1" (26 mm) CS: 2 3/8" X 16 1/2" CI: 2 3/8" X 16 1/2" EDA: 11 1/2"</p> <p>ENTRADA: 1 5/16" SALIDA: 1 5/16"</p> <p>102</p>
<p>0333 DPI CHEVROLET/GM/PONTIAC</p>  <p>Toma 45°</p> <p>BERETTA/CORSICA 87-91/TEMPEST 87-89 DPI 333 / 2405 PHAR L4 2.0 V6 2.8</p> <p>PANAL: 26" X 15" X 1 3/8" CS: 2 1/2" X 16 1/2" CI: 2 1/2" X 16 1/2" EDA: 11 1/2" EDAM: NO</p> <p>ENTRADA: 1 5/16" SALIDA: 1 5/16"</p> <p>103</p>	<p>0951 DPI CHEVROLET/GM/PONTIAC</p>  <p>Toma de sensor</p> <p>FIREBIRD/CAMARO/P SERIES 26 A 82-92/89-90 DPI 951 L4 2.5 V6 3.1/3.8 V8 5.0/5.7</p> <p>PANAL: 26 1/4" X 17 1/4" X 1 3/8" CS: 2 1/2" X 18 5/8" CI: 2 1/2" X 18 5/8" EDA: 11 1/2" EDAM: NO</p> <p>ENTRADA: 1 5/16" SALIDA: 1 9/16"</p> <p>104</p>	<p>1206 DPI CHEVROLET/GM/BUICK/PONTIAC</p>  <p>Base para sensor</p> <p>REGAL 91-93/GRAND PRIX/LUMINA/CUTLASS 91-93 DPI 1206 / 6009 PHAR V6 3.1</p> <p>PANAL: 28 1/4" X 15" X 1" (26 mm) CS: 2 1/2" X 16 1/2" CI: 2 1/2" X 16 1/2" EDA: 11 1/2" 4 PLACAS EDAM: NO</p> <p>ENTRADA: 1 5/16" SALIDA: 1 5/16"</p> <p>105</p>
<p>1344 DPI CHEVROLET/GM/BUICK/PONTIAC</p>  <p>Toma 90°</p> <p>SKYLARK/GRAND AM 92-93/BERETTA/CORSICA 92-94 DPI 1344 / 2276 PHAR L4 2.2/2.3 V6 3.1</p> <p>PANAL: 26" X 15" X 1 3/8" CS: 2 1/2" X 16 1/2" CI: 2 1/2" X 16 1/2" EDA: 11 1/2" 3 PLACAS EDAM: NO NOTAS: Puede usar 1341</p> <p>ENTRADA: 1 5/16" SALIDA: 1 5/16"</p> <p>106</p>	<p>1476 DPI CHEVROLET/GM/OLDSMOBILE/PONTIAC</p>  <p>Sensor</p> <p>SILHOUTTE92-95/TRANS SPORT/LUMINA APV 92-96 DPI 1476 V6 3.8</p> <p>PANAL: 28 1/4" X 17 1/4" X 1 3/8" CS: 2 1/2" X 18 3/4" CI: 2 1/2" X 18 3/4" EDA: 11 1/2" 4 PLACAS EDAM: 11 1/2" 4 PLACAS</p> <p>ENTRADA: 1 1/4" SALIDA: 1 1/4"</p> <p>107</p>	<p>1486 DPI CHEVROLET/GM/PONTIAC</p>  <p>Toma de calefacción</p> <p>FIREBIRD 93-02/CAMARO/TRANS AM 93-97 DPI 1486 V8 5.7</p> <p>PANAL: 28 1/4" X 17 1/4" X 1 3/8" CS: 2 3/8" X 18 5/8" CI: 2 3/8" X 18 5/8" EDA: 11/12" EDAM: NO</p> <p>ENTRADA: 1 1/4" SALIDA: 1 1/4"</p> <p>108</p>

<p>1489 DPI CHEVROLET/GM</p>  <p>Sensor y toma de calefacción</p> <p>SAVANA/EXPRESS 92-96</p> <p>6028 PHAR V6 4.3 V8 5.0/5.7</p> <p>PANAL: 30 1/2" X 17 1/4" X 1 3/8" CS: 2 1/2" X 18 3/4" CI: 2 1/2" X 18 3/4" EDA: 11 1/2" 4 PLACAS EDAM: 11 1/2" 4 PLACAS</p> <p>ENTRADA: 1 1/4" SALIDA: 1 1/2"</p> <p>109</p>	<p>1518 DPI CHEVROLET/GM/BUICK/OLDSMOBILE</p>  <p>Toma curva</p> <p>Sensor afuera</p> <p>CUTLAS/REGAL/LUMINA 94-97</p> <p>DPI 1518 / 6019 PHAR V6 3.1/3.4/3.8</p> <p>PANAL: 30 1/2" X 15 X 1" CS: 2 1/2" X 16 5/8" CI: 2 1/2" X 16 5/8" EDA: 11 1/2" 4 PLACAS EDAM: NO</p> <p>ENTRADA: 1 5/16" SALIDA: 1 5/16"</p> <p>110</p>	<p>1519 DPI CHEVROLET/GM/BUICK/PONTIAC</p>  <p>Toma curva</p> <p>Sensor afuera</p> <p>REGAL/GRAND PRIX/LUMINA 94-01</p> <p>DPI 1519 / 6019 PHAR V6 3.1/3.4/3.8</p> <p>PANAL: 30 1/2" X 15" X 5/8" (16 mm) CS: 2 1/2" X 16 5/8" CI: 2 1/2" X 16 5/8" EDA: 11 1/2" 4 PLACAS EDAM: NO</p> <p>ENTRADA: 1 5/16" SALIDA: 1 5/16"</p> <p>111</p>
<p>1522 DPI CHEVROLET/GM</p>  <p>Tomas de calefacción</p> <p>PICK UP C/K SERIES/SUBURBAN 96-99</p> <p>DPI 1522 V8 5.0/5.7</p> <p>PANAL: 34" X 17 1/4" X 1 3/8" CS: 3 1/4" X 18 1/2" CI: 3 1/4" X 18 1/2" EDA: 11 1/2" 7 PLACAS EDAM: 11 1/2" 6 PLACAS</p> <p>ENTRADA: 1 5/16" SALIDA: 1 9/16"</p> <p>112</p>	<p>1532 DPI CHEVROLET/GM</p>  <p>Toma curva</p> <p>JIMMY/SONOMA/S-10/BLAZER 93-95</p> <p>6237 PHAR V6 4.3</p> <p>PANAL: 26 1/4" X 15" X 7/8" (22 mm) CS: 2 1/2" X 16 5/8" CI: 2 1/2" X 16 5/8" EDA: NO EDAM: 11 1/2"</p> <p>ENTRADA: 1 5/16" SALIDA: 1 9/16"</p> <p>113</p>	<p>1692 DPI CHEVROLET/GM</p>  <p>PICK UP 95-97</p> <p>V6 4.3 V8 5.0/5.7</p> <p>PANAL: 28 1/4" X 17 1/4" X 1" (26 mm) CS: 18 9/16" X 2 9/32" CI: 18 9/16" X 2 9/32" EDA: SI 11 1/2" EDAM: SI 11 1/2"</p> <p>ENTRADA: 1 5/16" SALIDA: 1 5/16"</p> <p>114</p>
<p>1694 DPI CHEVROLET/GM</p>  <p>Panál delgado usar A1693</p> <p>ESCALADE/C/K SERIES 00/SUBURBAN 94-95</p> <p>DPI 1694 / 6033 PHAR V8 5.0/5.7</p> <p>PANAL: 34" X 17 1/4" X 2 1/8" CS: 3 1/4" X 18 1/2" CI: 3 1/4" X 18 1/2" EDA: 11 1/2" 7 PLACAS EDAM: 11 1/2" 6 PLACAS</p> <p>ENTRADA: 1 5/16" SALIDA: 1 9/16"</p> <p>115</p>	<p>1696 DPI CHEVROLET/GM</p>  <p>C/K SERIES PICK UP/KODIAK/SUBURBAN 94-00</p> <p>2508 PHAR V8 7.4</p> <p>PANAL: 34" X 19 1/2" X 2 1/8" CS: 3 1/4" X 20 3/4" CI: 3 1/4" X 20 3/4" EDA: 11 1/2" 7 PLACAS EDAM: 11 1/2" 6 PLACAS</p> <p>ENTRADA: 1 5/16" SALIDA: 1 9/16"</p> <p>116</p>	<p>1706 DPI CHEVROLET/GM</p>  <p>Toma de calefacción y sensor</p> <p>G SERIES VAN EXPRESS 93-96</p> <p>6028 PHAR V6 4.3 V8 5.0/5.7</p> <p>PANAL: 30 1/2" X 17 1/4" X 1 3/8" CS: 2 1/2" X 18 3/4" CI: 2 1/2" X 18 3/4" EDA: 11 1/2" 4 PLACAS EDAM: 11 1/2" 4 PLACAS</p> <p>ENTRADA: 1 5/16" SALIDA: 1 9/16"</p> <p>117</p>

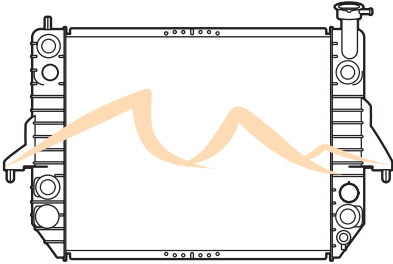
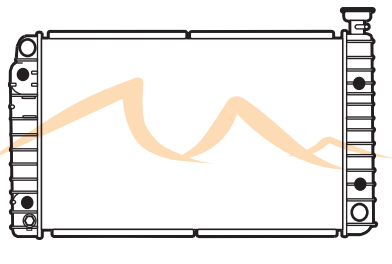
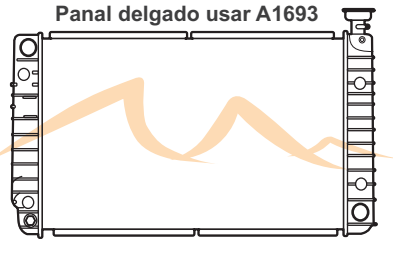
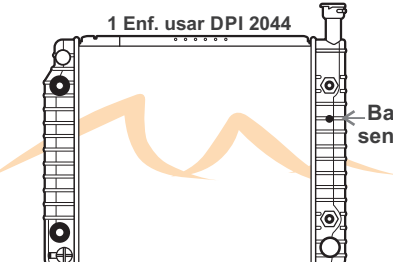
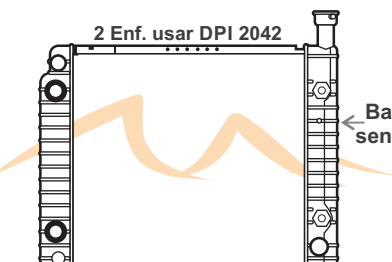
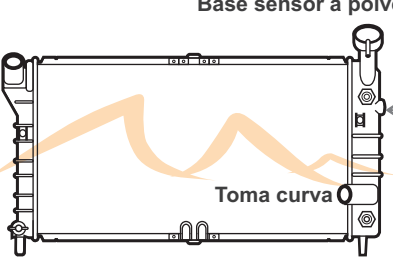
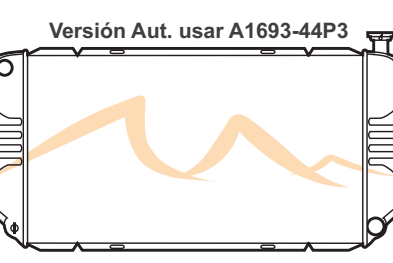
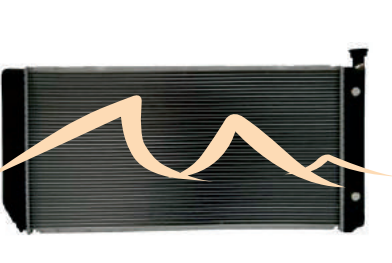
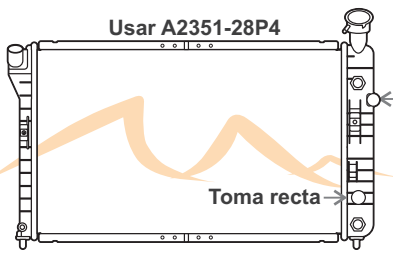
<p>1786 DPI CHEVROLET/GM</p>  <p>ASTRO/SAFARI VAN 96-97 V6 3.8</p> <p>PANAL: 28 1/4" X 17 1/2" X 1" (26 mm) CS: 2 5/16" X 18 5/8" ENTRADA: 1 5/16" CI: 2 5/16" X 18 5/8" SALIDA: 1 9/16" EDA: 11 1/2" 4 PLACAS EDAM: 11 1/2" 3 PLACAS</p> <p style="text-align: right;">118</p>	<p>1788 DPI CHEVROLET/GM</p>  <p>G SERIES VAN/C/K SERIES 93-98 DPI 1790 V6 4.3 / V8 5.7</p> <p>PANAL: 28 1/4" X 17 1/4" X 7/8" (22 mm) CS: 2 3/8" X 18 5/8" ENTRADA: 1 1/4" CI: 2 3/8" X 18 5/8" SALIDA: 1 9/16" EDA: 11 1/2" 5 PLACAS EDAM: 11 1/2" 4 PLACAS</p> <p style="text-align: right;">119</p>	<p>1792 DPI CHEVROLET/GM</p>  <p>Panel delgado usar A1693</p> <p>C/K SERIES/SUBURBAN/TAHOE 94-99 6033 PHAR V8 5.0/5.7</p> <p>PANAL: 34" X 17 1/4" X 2 1/4" (56 mm) CS: 3 3/8" X 18 1/2" ENTRADA: 1 5/16" CI: 3 3/8" X 18 1/2" SALIDA: 1 9/16" EDA: 11 1/2" 7 PLACAS EDAM: 11 1/2" 6 PLACAS NOTAS: Puede usar 1693</p> <p style="text-align: right;">120</p>
<p>2042 DPI CHEVROLET/GM</p>  <p>1 Enf. usar DPI 2044</p> <p>G SERIES/SAVANA/VAN EXPRESS 96-98/99-02 V6 4.3 V8 5.0/5.7</p> <p>PANAL: 30 1/2" X 17 1/2" X 1 1/4" (32 mm) CS: 2 1/2" X 18 3/4" ENTRADA: 1 5/16" CI: 2 1/2" X 18 3/4" SALIDA: 1 9/16" EDA: 11 1/2" 4 PLACAS EDAM: 11 1/2" 4 PLACAS</p> <p style="text-align: right;">121</p>	<p>2044 DPI CHEVROLET/GM</p>  <p>2 Enf. usar DPI 2042</p> <p>EXPRESS G/SAVANA/SERIES VAN 99-02/96-98 V6 4.3 V8 5.0/5.7</p> <p>PANAL: 30 1/2" X 17 1/2" X 1 1/4" (32 mm) CS: 2 7/16" X 18 3/4" ENTRADA: 1 5/16" CI: 2 7/16" X 18 3/4" SALIDA: 1 9/16" EDA: 11 1/2" 4 PLACAS EDAM: NO</p> <p style="text-align: right;">122</p>	<p>2251 DPI CHEVROLET/GM/PONTIAC</p>  <p>Base sensor a polvera</p> <p>Toma curva</p> <p>GRAND PRIX/LUMINA/MONTECARLO 96-01 6019 PHAR V6 3.1/3.4/3.8</p> <p>PANAL: 30 1/2" X 15 5/16" X 1" (26 mm) CS: 2 7/16" X 16 9/16" ENTRADA: 1 5/16" CI: 2 7/16" X 16 9/16" SALIDA: 1 5/16" EDA: 11 1/2" 4 PLACAS EDAM: NO</p> <p style="text-align: right;">123</p>
<p>2316 DPI CHEVROLET/GM</p>  <p>Versión Aut. usar A1693-44P3</p> <p>SILVERADO/C/K SERIES/SUBURBAN 96-00 1734 PHAR V8 5.0/5.7</p> <p>PANAL: 34" X 17 1/4" X 1" (26 mm) CS: 3 3/16" X 18 1/2" ENTRADA: 1 5/16" CI: 3 3/16" X 18 1/2" SALIDA: 1 9/16" EDA: NO EDAM: NO NOTAS: ST.</p> <p style="text-align: right;">124</p>	<p>2317 DPI CHEVROLET/GM/CADILLAC</p>  <p>ESCALADE 99-00/C/K SERIES/TAHOE/SILVERADO 96-00 1734 PHAR A.T. V8 5.0/5.7</p> <p>PANAL: 34" X 17 1/4" X 1" (26 mm) CS: 3 3/16" X 18 1/2" ENTRADA: 1 5/16" CI: 3 3/16" X 18 1/2" SALIDA: 1 9/16" EDA: 11 1/2" 4 PLACAS</p> <p style="text-align: right;">125</p>	<p>2343 DPI CHEVROLET/GM/BUICK</p>  <p>Usar A2351-28P4</p> <p>Toma recta</p> <p>Base sensor a motor</p> <p>REGAL/MONTE CARLO/CENTURY/IMPALA 00-05/00-03 6219 PHAR V6 3.1/3.4/3.8</p> <p>PANAL: 30 1/2" X 15 1/16" X 5/8" (16 mm) CS: 2 5/16" X 16 7/16" ENTRADA: 1 1/4" CI: 2 5/16" X 16 7/16" SALIDA: 1 1/4" EDA: 11 1/2" 3 PLACAS EDAM: NO</p> <p style="text-align: right;">126</p>

2370 DPI CHEVROLET/GM/CADILLAC

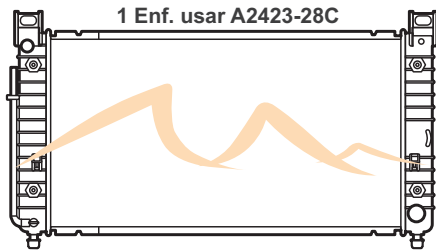

ESCALADE 03-13/YUKON/TAHOE 99-14/08-13
V6 4.3 V8 4.8/5.3/6.0/6.2

PANAL: 34" X 17 1/2" X 1" (26 mm)
CS: 3 3/16" X 18 5/8" ENTRADA: 1 5/16"
CI: 3 3/16" X 18 5/8" SALIDA: 1 9/16"
EDA: 11 1/2" 7 PLACAS
EDAM: 11 1/2" 6 PLACAS

127

2563 DPI CHEVROLET/GM/BUICK

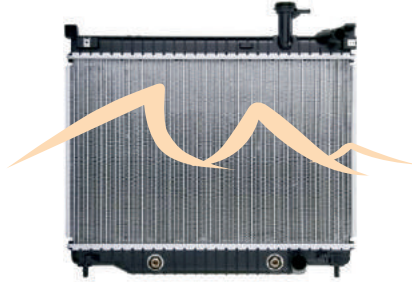

DENALI 04-07/RAINIER/TRAIL BLAZER 06-09
V8 5.3/6.0

PANAL: 27 5/8" X 13 11/16" X 1 1/16"
CS: 18" X 26 7/8" ENTRADA: 1 5/16"
CI: 18" X 26 7/8" SALIDA: 1 9/16"
EDA: 11 1/2"
EDAM: NO

128

2710 DPI CHEVROLET/GM/BUICK/PONTIAC

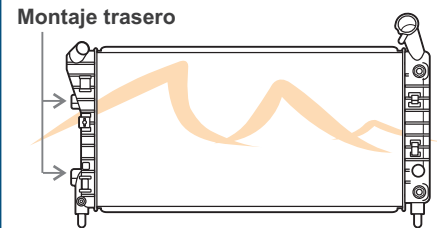

ALLURE/LA CORSE/IMPALA/
GRAND PRIX 04-08/MONTECARLO 04-05
V6 3.4/3.8

PANAL: 30 1/2" X 14 9/16" X 5/8" (16 mm)
CS: 1 7/8" X 14 15/16" ENTRADA: 1 5/16"
CI: 1 7/8" X 14 15/16" SALIDA: 1 5/16"
EDA: SI
EDAM: NO

129

2727 DPI CHEVROLET/PONTIAC/SATURN

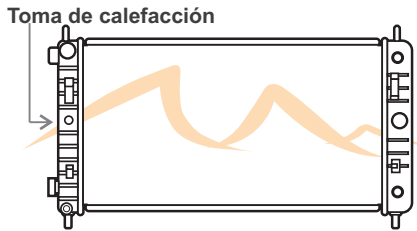

AURA 07-08/G6/MALIBU 05-10/04-10
V6 3.5/3.9

PANAL: 26 3/4" X 14 1/2" X 1" (26 mm)
CS: 1 7/8" X 14 15/16" ENTRADA: 1 5/16"
CI: 1 7/8" X 14 15/16" SALIDA: 1 3/8"
EDA: SI
EDAM: NO

130

2774 DPI CHEVROLET/GM/PONTIAC/SUZUKI

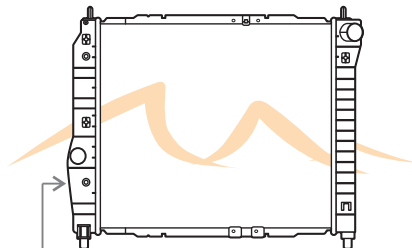

SWIRTT/WAVE/G3/AVEO 04-08
L4 1.6

PANAL: 16 3/8" X 18 7/8" X 5/8" (16 mm)
CS: 1 13/16" X 17 5/16" ENTRADA: 1 5/16"
CI: 1 13/16" X 17 5/16" SALIDA: 1 5/16"
EDA: SI
EDAM: NO

131

2810 DPI CHEVROLET/GM

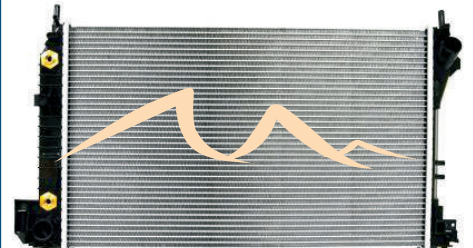

VECTRA 03-11
L4 2.0 V6 2.8/3.2

PANAL: 25 9/16" X 15 11/16" X 1 1/4"
CS: 2 3/8" X 16 11/32" ENTRADA: 1 5/16"
CI: 2 3/8" X 16 11/32" SALIDA: 1 5/16"
EDA: SI Concéntrico
EDAM:

132

2855 DPI CHEVROLET/GM

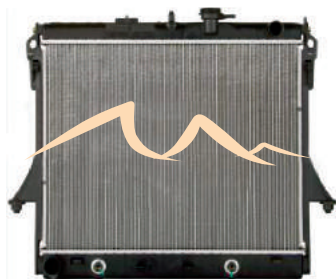

COLORADO 09-12/CANYON 09-12/HUMMER H3, H3T 06-10
V8 5.3 L5 3.5/3.7

PANAL: 18 1/2" X 22 15/16" X 15/16"
CS: 2 3/8" X 23 8/16" ENTRADA: 1 5/16"
CI: 2 3/8" X 23 8/16" SALIDA: 1 9/16"
EDA: SI 4 Placas
EDAM: NO

133

2864 DPI CHEVROLET/PONTIAC/SATURN

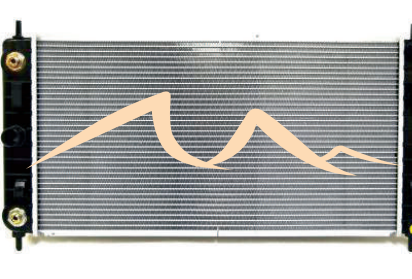

MALIBU 08-12/ G6 6-10/ AURA 07-09
L4 2.4 V6 3.6

PANAL: 26 3/4" X 14 5/8" X 1 5/16"
CS: 2 1/16" X 15 1/16" ENTRADA: 1 5/16"
CI: 2 1/16" X 15 1/16" SALIDA: 1 5/16"
EDA: SI 3 Placas
EDAM: NO

134

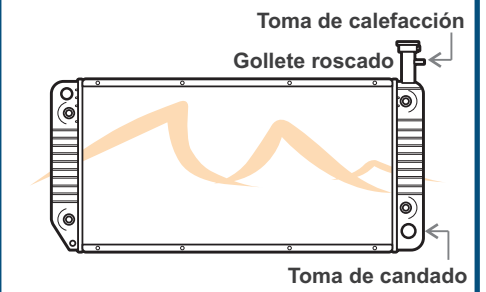

2866 DPI CHEVROLET/GMC



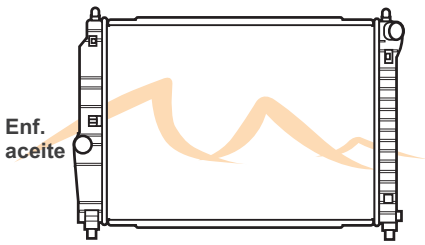
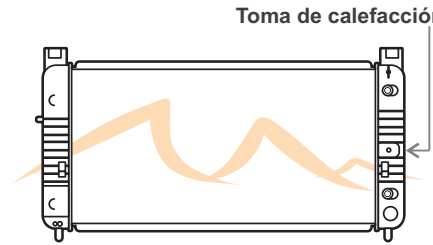
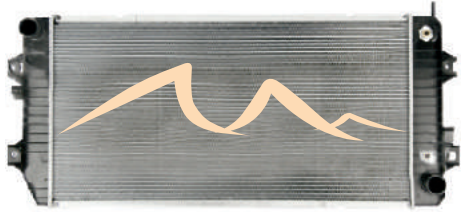
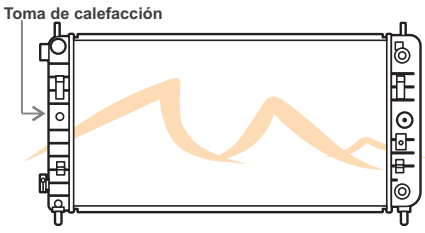

EXPRESS/SAVANNA 05-07
V8 4.8/6.0

PANAL: 34" X 17 1/4" X 1" (26 mm)
CS: 18 1/2" X 3" ENTRADA: 1 1/4"
CI: 18 1/2" X 3" SALIDA: 1 1/2"
EDA: SI
EDAM: SI

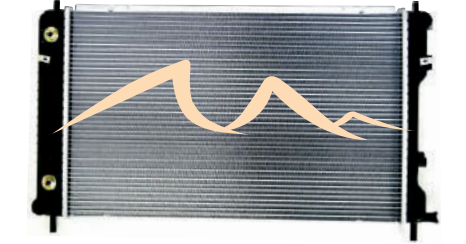
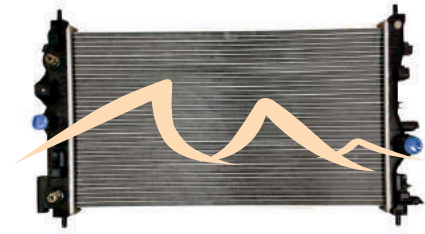
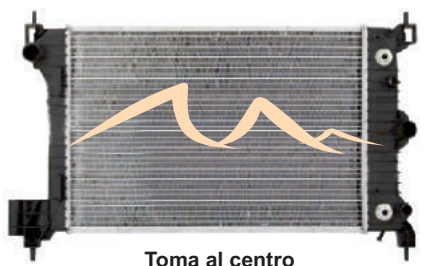
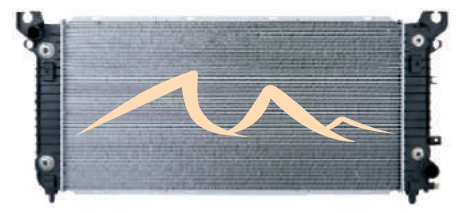

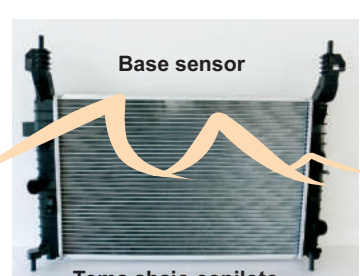
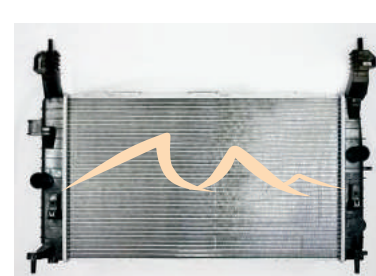
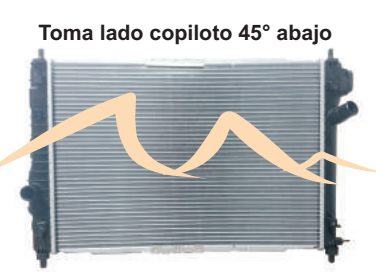
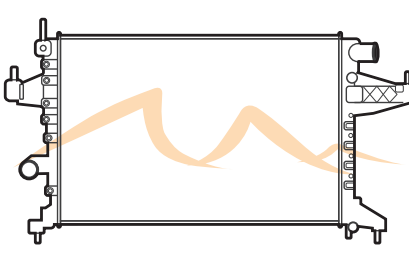
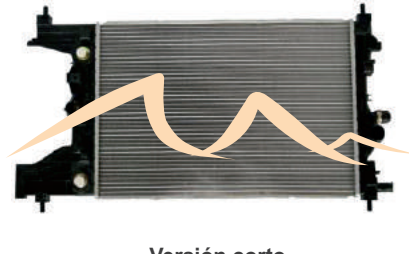
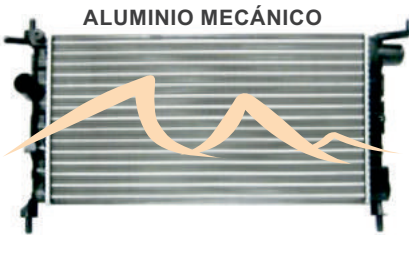
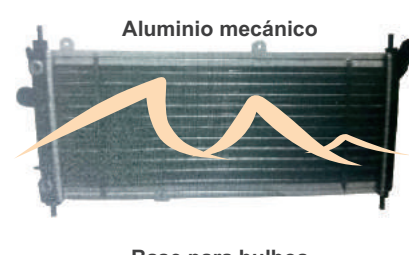
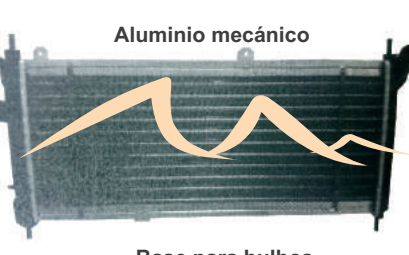
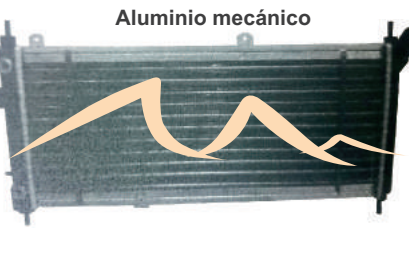
135

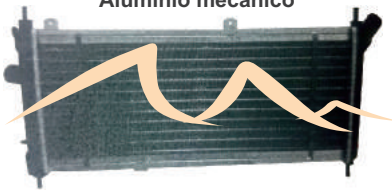
<p>2873 DPI CHEVROLET/GM/PONTIAC/SUZUKI</p>  <p>SWIFT/WAVE/G3/AVEO 04-08 L4 1.5/1.6</p> <p>PANAL: 23 5/8" X 16 3/8" X 5/8" (16 mm) CS: 2" X 17 9/16" ENTRADA: 1 3/8" CI: 2" X 17 9/16" SALIDA: 1 3/8" EDA: 10" 3 PLACAS EDAM: NO</p> <p style="text-align: right;">136</p>	<p>2921 DPI CHEVROLET/GMC/CADILLAC</p>  <p>Usar A2423-28C</p> <p>ESCALADE/SUBURBAN/TAHOE/YUKON 04-09 V8 4.8/5.3/6.0/6.2</p> <p>PANAL: 34" X 17 1/2" X 1" (26 mm) CS: 3 3/16" X 18 5/8" ENTRADA: 1 5/16" CI: 3 3/16" X 18 5/8" SALIDA: 1 9/16" EDA: SI (7 PLACAS)</p> <p style="text-align: right;">137</p>	<p>2935 DPI CHEVROLET</p>  <p>EXPRESS GMC SAVANA 06-16 DIESEL 6.6L</p> <p>PANAL: 34" X 17 1/8" X 1 1/4" CS: 3 1/8" X 18 3/8" ENTRADA: 1 13/16" CI: 3 1/8" X 18 3/8" SALIDA: 1 13/16" EDA: SI</p> <p style="text-align: right;">138</p>
<p>2972 DPI CHEVROLET/GMC/PONTIAC</p>  <p>MALIBU/G6 06-10 V6 3.5/3.6/3.9</p> <p>PANAL: 26 3/4" X 14 1/4" X 1" (26 mm) CS: 1 7/8" X 14 15/16" ENTRADA: 1 5/16" CI: 1 7/8" X 14 15/16" SALIDA: 1 5/16" EDA: SI (3 PLACAS)</p> <p style="text-align: right;">139</p>	<p>13057 DPI CHEVROLET/SATURN</p>  <p>CAPTIVA SPORT/VUE 08-15 L4 2.4 / V6 3.0 / 3.5 / 3.6</p> <p>PANAL: 26 1/2" X 19 3/4" X 1" CAB. SUP.: 2 1/2" X 20 11/16" CAB. INF.: 2 1/2" X 20 11/16" Enfriador: SI</p> <p>TOMAS: ENTRADA: 1 5/16" SALIDA: 1 5/16"</p> <p style="text-align: right;">140</p>	<p>13103 DPI CHEVROLET/GM/PONTIAC/SUZUKI</p>  <p>EQUINOX 08-15/TERRAIN 10-14/TORRENT 10-14/XL-7 07-09 L4 2.4 V6 3.0/3.6</p> <p>PANAL: 26 11/16" X 16 11/16" X 1" CS: 2 7/16" X 17 1/8" ENTRADA: 1 5/16" CI: 2 7/16" X 17 1/8" SALIDA: 1 5/16" EDA: SI</p> <p>CONDENSADOR: AC3789</p> <p style="text-align: right;">141</p>
<p>13197 DPI CHEVROLET</p>  <p>CRUZE 10-15 DPI 13197 L4 1.4/1.8</p> <p>PANAL: 26 3/4" X 15 11/16" X 1" CAB. SUP.: 2 1/16" X 16 3/16" CAB. INF.: 2 1/16" X 16 3/16" Enfriador: SI</p> <p>TOMAS: ENTRADA: 1 5/16" SALIDA: 1 1/2"</p> <p>CONDENSADOR: AC3794</p> <p style="text-align: right;">142</p>	<p>13247 DPI CHEVROLET</p>  <p>SONIC 12-16 L4 1.6/1.8</p> <p>PANAL: 21 5/8" X 14 1/2" X 5/8" CI: 1 7/16" X 15 11/16" ENTRADA: 1 3/8" CD: 1 7/16" X 15 11/16" SALIDA: 1 3/8" EDA: NO</p> <p style="text-align: right;">143</p>	<p>13396 DPI CHEVROLET</p>  <p>SILVERADO 1500 GMC SIERRA 1500 14-16 V6 4.3</p> <p>PANAL: 34 1/16" X 17 1/8" X 7/8" CI: 2 5/32" X 17 5/16" ENTRADA: 1 5/16" CD: 2 1/4" X 17 5/16" SALIDA: 1 9/16" EDA: SI</p> <p style="text-align: right;">144</p>

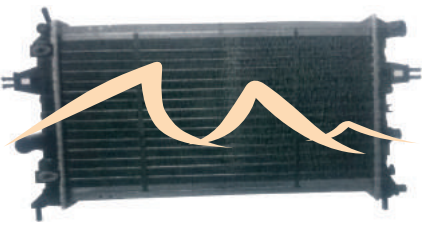
<p>LHRP404 CHEVROLET</p>  <p>Base sensor</p> <p>Toma abajo copiloto</p> <p>OPEL MERIVA 03-10 1.7 DTI</p> <p>PANAL: 23 15/16" X 14 1/8" X 1 1/8" CAB. SUP.: 2 1/8" X 14 11/16" CAB. INF.: 2 1/8" X 14 11/16" Enfriador: NO</p> <p>TOMAS: ENTRADA: 1 1/2" SALIDA: 1 3/8"</p> <p>145</p>	<p>LHRP614 CHEVROLET</p>  <p>OPEL MERIVA 03-10 L4 1.4/1.6/1.8</p> <p>PANAL: 23 15/16" X 14 1/8" X 1 1/8" CAB. SUP.: 2 1/8" X 14 11/16" CAB. INF.: 2 1/8" X 14 11/16" Enfriador: NO</p> <p>TOMAS: ENTRADA: 1 7/16" SALIDA: 1 3/8"</p> <p>146</p>	<p>LHRP624-16 CHEVROLET</p>  <p>Toma lado copiloto 45° abajo</p> <p>AVEO 09-11 L4 1.6/16V</p> <p>PANAL: 23 11/16" X 16 1/2" X 5/8" CAB. SUP.: 2 13/16" X 17 1/4" CAB. INF.: 2 13/16" X 17 1/4" Enfriador: NO</p> <p>TOMAS: ENTRADA: 1 3/8" SALIDA: 1 3/8"</p> <p>147</p>
<p>LHRP0152-26MT CHEVROLET</p>  <p>CORSA/TORNADO 04-10 1.8 16V</p> <p>PANAL: 21 1/4" X 13 49/64" X 5/8" (26mm) CI: 1 5/8" X 15 3/8" CD: 1 5/8" X 15 3/8" EDA: NO EDAM:</p> <p>ENTRADA: 1 11/32" SALIDA: 1 11/32"</p> <p>148</p>	<p>LHRP470 CHEVROLET</p>  <p>Versión corto</p> <p>CRUZE 09-13 L4 1.6/1.8 16V</p> <p>PANAL: 22 7/8" X 15 11/16" X 1" (26mm) CI: 2 1/16" X 16 3/16" CD: 2 1/16" X 16 3/16" EDA: SI</p> <p>ENTRADA: 1 5/16" SALIDA: 1 1/2"</p> <p>149</p>	<p>M005-26N CHEVROLET/GM</p>  <p>ALUMINIO MECÁNICO</p> <p>CHEVY JOY 94-11/POP-SWING/C2/PICK UP L4 1.4/1.6</p> <p>PANAL: 20 3/4" X 9 15/16" X 1" CS: 1 7/8" X 11 3/16" CI: 1 7/8" X 11 3/16" ENFRIADOR: NO</p> <p>ENTRADA: 1 5/16" SALIDA: 1 5/16"</p> <p>150</p>
<p>M2420-26C CHEVROLET/GMC</p>  <p>Aluminio mecánico</p> <p>Base para bulbos</p> <p>CHEVY C2/CONFORT/MONZA 98-04 2420 PHAR 1.2/1.4/1.6</p> <p>PANAL: 26 7/8" X 10 1/8" X 1" CAB. SUP.: 11 1/16" X 1 15/16" CAB INF.: 11 1/16" X 1 15/16" ENF. TRANS.: SI</p> <p>TOMAS: ENTRADA: 1 3/8" SALIDA: 1 3/8"</p> <p>151</p>	<p>M2420-26N CHEVROLET/GMC</p>  <p>Aluminio mecánico</p> <p>Base para bulbos</p> <p>CHEVY C2/CONFORT/MONZA 98-04 2420 PHAR 1.2/1.4/1.6</p> <p>PANAL: 26 7/8" X 10 1/8" X 1" CAB. SUP.: 11 1/16" X 1 15/16" CAB INF.: 11 1/16" X 1 15/16" ENF. TRANS.: NO</p> <p>TOMAS: ENTRADA: 1 3/8" SALIDA: 1 3/8"</p> <p>152</p>	<p>M6039-26C CHEVROLET/GMC</p>  <p>Aluminio mecánico</p> <p>Sin base para bulbos</p> <p>CHEVY C2/CONFORT/MONZA 98-04 6039 PHAR 1.4/1.6</p> <p>PANAL: 26 7/8" X 10 1/8" X 1" CAB. SUP.: 11 1/16" X 1 15/16" CAB INF.: 11 1/16" X 1 15/16" ENF. TRANS.: SI</p> <p>TOMAS: ENTRADA: 1 3/8" SALIDA: 1 3/8"</p> <p>153</p>

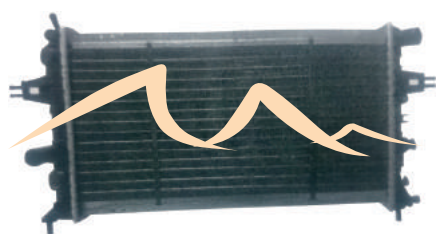
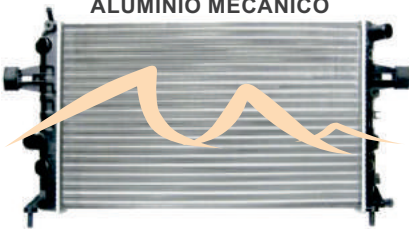
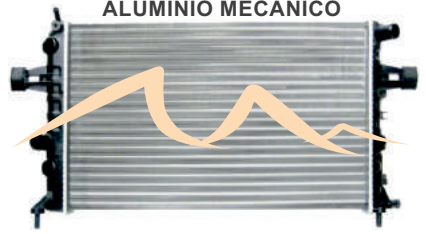
M6039-26N CHEVROLET/GMC	M7023-26N CHEVROLET/GM	M7024-26C CHEVROLET
Aluminio mecánico	ALUMINIO MECÁNICO	
		
Sin base para bulbos		
CHEVY C2/CONFORT/MONZA 98-04	CORSA/TORNADO 04-10	ASTRA 02-08
6039 PHAR 1.4/1.6	1.8 16V	L4 1.8/2.0 / 16V
PANAL: 26 7/8" X 10 1/8" X 1" CAB. SUP.: 11 1/16" X 1 15/16" CAB INF.: 11 1/16" X 1 15/16" ENF. TRANS.: NO TOMAS: ENTRADA: 1 3/8" SALIDA: 1 3/8"	PANAL: 21 1/2" X 14 1/8" CS: 1 5/8" X 15 3/8" CI: 1 5/8" X 15 3/8" ENFRIADOR: NO ENTRADA: 1 3/8" SALIDA: 1 3/8"	PANAL: 23 5/8" X 13 1/8" X 1" CS: 15 1/2" X 2 3/16" CI: 15 1/2" X 2 3/16" EDA: SI 10" ENTRADA: 1 3/8" SALIDA: 1 3/8"
154	155	156

M7024-26N CHEVROLET	7024-24M CHEVROLET/GM	7024-32M CHEVROLET/GM
	ALUMINIO MECÁNICO	ALUMINIO MECÁNICO
		
ASTRA 02-08	ASTRA/ZAFIRA 02-08	ASTRA/ZAFIRA 02-08
L4 1.8/2.0 / 16V	OL 0090 2.2/2.0 16V	PHAR 7024 2.0/2.2 16V
PANAL: 23 5/8" X 13 1/8" X 1" CS: 15 1/2" X 2 3/16" CI: 15 1/2" X 2 3/16" EDA: NO ENTRADA: 1 3/8" SALIDA: 1 3/8"	PANAL: 23 3/4" X 14 7/8" X 7/8" CS: 15 1/2" X 2 1/4" CI: 16 1/2" X 1 3/4" ENFRIADOR: NO ENTRADA: 1 1/4" SALIDA: 1 1/4"	PANAL: 23 5/8" X 14 1/8" X 1 1/4" CS: 2 1/4" X 15 9/16" CI: 2 1/4" X 15 9/16" ENFRIADOR: NO ENTRADA: 1 3/8" SALIDA: 1 3/8"
157	158	159

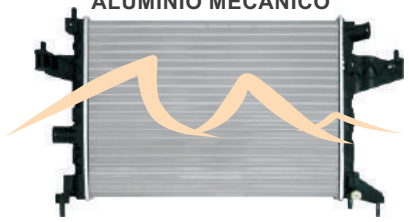
OL0010-24M CHEVROLET/GM	OL0100-24M CHEVROLET/GM	 www.phar.com.mx
ALUMINIO MECÁNICO	ALUMINIO MECÁNICO	
		
CHEVY/JOY POP 94-03	CORSA/TORNADO 04-06	
OL 0010 1.1/1.6 16V	OL 0100 1.8 16V	
PANAL: 20 7/8" X 11 1/4" X 7/8" CS: 11 1/4" X 1 1/2" CI: 11 1/4" X 1 1/2" ENFRIADOR: NO ENTRADA: 1 1/4" SALIDA: 1 1/4"	PANAL: 21 1/4" X 13 49/64" X 7/8" CS: 1 5/8" X 15 3/8" CI: 1 5/8" X 15 3/8" ENFRIADOR: NO ENTRADA: 1 3/8" SALIDA: 1 3/8"	
160	161	



NOTAS

Large lined area for notes, containing a faint orange graphic at the bottom.

Radiadores

PHAR

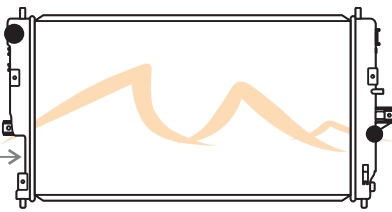
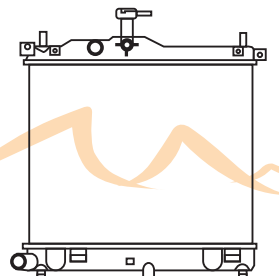
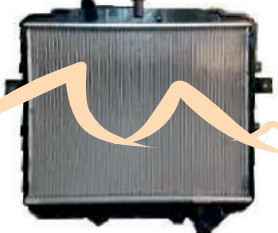
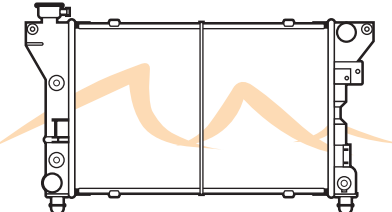
- **CHRYSLER**
- **DODGE**

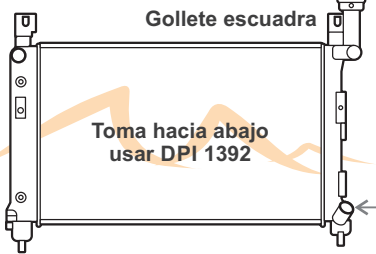
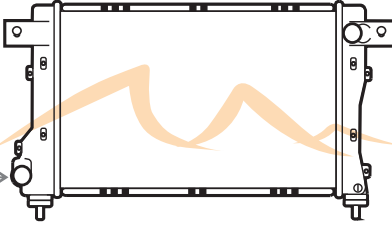
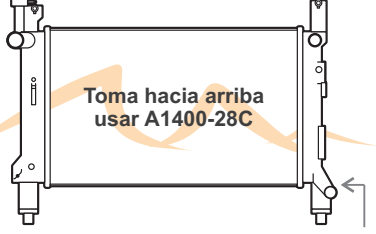
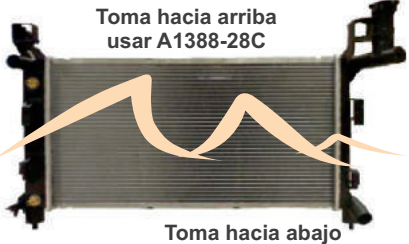
<p>A003-28N CHRYSLER/DODGE</p>  <p>Medio tanque</p> <p>STRATUS RT TURBO 02-07</p> <p>L4 2.4</p> <p>PANAL: 26 9/16" X 14 7/8" X 1 1/8" CS: 2" X 15 9/16" CI: 2" X 15 9/16"</p> <p>ENTRADA: 1 3/8" SALIDA: 1 1/4"</p> <p>ENFRIADOR: NO</p> <p>001</p>	<p>A015-28N DODGE/HYUNDAI</p>  <p>i10 09-13</p> <p>L4 1.0/1.1/1.2 12V</p> <p>PANAL: 13 3/4" X 18 1/5" X 1 1/8" CS: 1 13/16" X 17 3/4" CI: 1 13/16" X 17 3/4"</p> <p>ENTRADA: 1 1/8" SALIDA: 1 1/8"</p> <p>ENFRIADOR: NO</p> <p>002</p>	<p>A034-28N DODGE/HYUNDAI</p>  <p>Gollete al centro</p> <p>Toma Escuadra</p> <p>H100 STD 99-07</p> <p>L4 2.5/2.6</p> <p>8178 PHAR</p> <p>PANAL: 15 3/4" X 22 7/16" X 1 1/8" CAB. SUP.: 23 5/16" X 2 1/8" CAB. INF.: 23 5/16" X 2 1/8"</p> <p>ENF. TRANS.: NO ENF. MOTOR: NO 02/15</p> <p>TOMAS: ENTRADA: 1 5/16" SALIDA: 1 5/16"</p> <p>003</p>
<p>A1108-28C CHRYSLER/DODGE</p>  <p>DAYTON/SPIRITSHADOW 91-94</p> <p>DPI 1108 / 2211 PHAR L4 2.2/2.5 V6 3.0</p> <p>PANAL: 14 7/8" X 22 1/2" X 1 1/8" (28 mm) CS: 1 3/4" X 15 1/8" CI: 1 3/4" X 15 1/8"</p> <p>ENTRADA: 1 5/16" SALIDA: 1 5/16"</p> <p>ENFRIADOR: SI 756305</p> <p>004</p>	<p>A1125-28C CHRYSLER/DODGE/PLYMOUTH</p>  <p>Doble toma recuperador</p> <p>Tomas lado copiloto hacia derecha</p> <p>VOYAGER 90-92/CARAVAN 90-92/TOWN COUNTRY 90-92</p> <p>DPI 1125 L4 2.5 V6 3.0/3.3</p> <p>PANAL: 15 7/8" X 16 X 1 1/8" CS: 2 1/2" X 16 15/16" CI: 2 1/2" X 16 15/16" EDA: SI</p> <p>ENTRADA: 1 1/4" SALIDA: 1 1/4"</p> <p>005</p>	<p>A1388-28C CHRYSLER/DODGE</p>  <p>Gollete escuadra</p> <p>Toma hacia abajo usar DPI 1392</p> <p>Toma hacia arriba</p> <p>CARAVAN/VOYAGER 93-95</p> <p>DPI 1388 / 2226 PHAR L4 2.5 V6 3.3/3.8</p> <p>PANAL: 25 3/4" X 15 1/2" X 1 1/8" CS: 2 3/8" X 15 5/8" CI: 2 3/8" X 15 5/8"</p> <p>ENTRADA: 1 1/4" SALIDA: 1 1/4"</p> <p>ENFRIADOR: SI</p> <p>006</p>
<p>A1390-28C CHRYSLER/DODGE</p>  <p>Toma hacia abajo</p> <p>NV LHS/CONCORD/INTREPID 93-97</p> <p>DPI 1390 / 2225 PHAR V6 3.3/3.5</p> <p>PANAL: 25" X 14 7/8" X 1 1/8" CS: 1 7/8" X 27 1/4" CI: 1 7/8" X 27 1/4"</p> <p>ENTRADA: 1 1/4" SALIDA: 1 1/4"</p> <p>ENFRIADOR: SI</p> <p>007</p>	<p>A1391-28C CHRYSLER/DODGE</p>  <p>Tomas mismo lado</p> <p>Toma hacia arriba usar A1400-28C</p> <p>Toma hacia abajo</p> <p>CARAVAN VOYAGER 93-95</p> <p>DPPI 1391 / 2224 PHAR V6 3.0</p> <p>PANAL: 26 9/16" X 15 1/2" X 1 1/8" CS: 2 3/8" X 15 5/8" CI: 2 3/8" X 15 5/8"</p> <p>ENTRADA: 1 1/4" SALIDA: 1 1/2"</p> <p>ENFRIADOR: SI NOTAS:</p> <p>008</p>	<p>A1392-28C DODGE</p>  <p>Toma hacia arriba usar A1388-28C</p> <p>Toma hacia abajo</p> <p>CARAVAN/GRAND CARAVAN/VOYAGUER/GRAND VOYAGUER 93-95</p> <p>V6 3.0</p> <p>PANAL: 25 5/8" X 14 7/16" X 1 1/8" CAB. SUP.: 20 9/16" X 2 1/2" CAB. INF.: 20 9/16" X 2 1/2"</p> <p>ENF. TRANS.: SI ENF. MOTOR: NO</p> <p>TOMAS: ENTRADA: 1 3/8" SALIDA: 1 1/4"</p> <p>009</p>

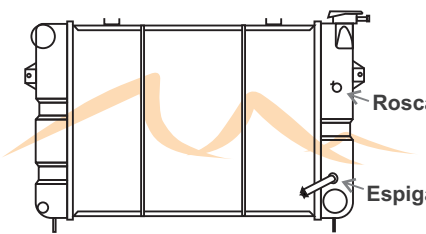
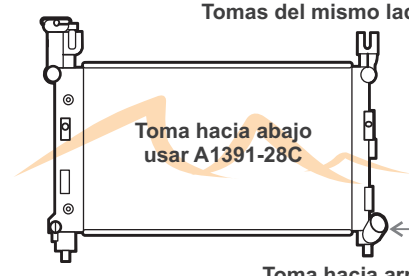
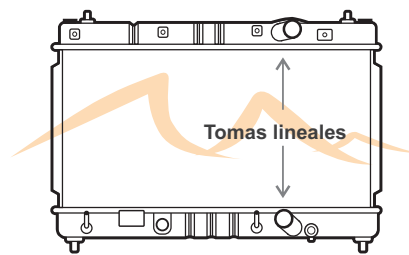
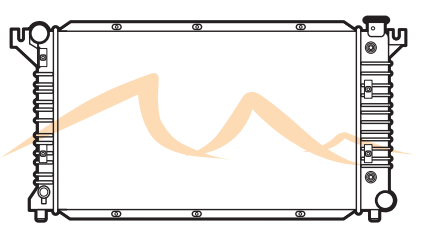
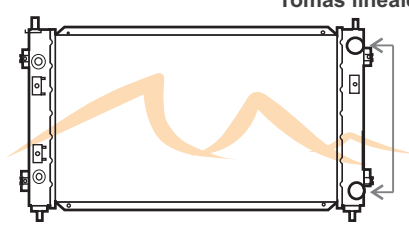
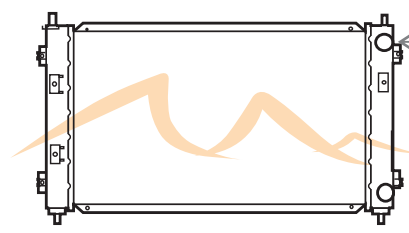
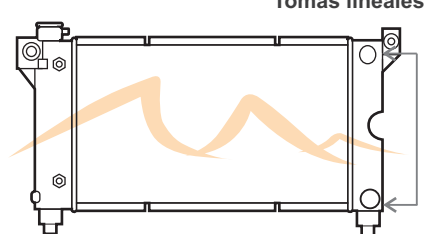
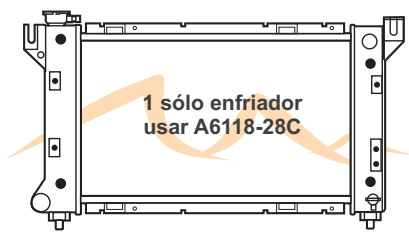
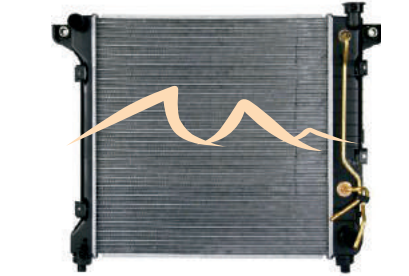
<p>A1394-28C CHRYSLER/DODGE/JEEP</p>  <p>GRAND CHEROKEE 93-97</p> <p>DPI 1394 / 2219 PHAR V8 5.2</p> <p>PANAL: 22 1/8" X 19 7/8" X 1 1/8" CS: 2 5/16" X 20 7/16" CI: 2 5/16" X 20 7/16"</p> <p>ENTRADA: 1 1/2" SALIDA: 1 3/4"</p> <p>ENFRIADOR: SI</p> <p>010</p>	<p>A1400-28C CHRYSLER/DODGE</p>  <p>CARAVAN/VOYAGER 93-95</p> <p>DPI 1400 / 2223 PHAR L4 2.5 V6 3.3/3.8</p> <p>PANAL: 25 3/4" X 15 1/2" X 1 1/8" CS: 2 3/8" X 15 5/8" CI: 2 3/8" X 15 5/8"</p> <p>ENTRADA: 1 1/4" SALIDA: 1 1/2"</p> <p>ENFRIADOR: SI</p> <p>011</p>	<p>A1548-13C CHRYSLER/DODGE</p>  <p>NEON 95-99</p> <p>DPI 1548 / 6014 PHAR L4 2.0</p> <p>PANAL: 11 3/4" X 23 3/4" X 1/2" CS: 1 1/2" X 24 1/2" CI: 1 3/4" X 24 1/2"</p> <p>ENTRADA: 1 1/4" SALIDA: 1 1/4"</p> <p>MAQ. 3.3 LTS</p> <p>ENFRIADOR: SI</p> <p>012</p>
<p>A1552-28C CHRYSLER/DODGE</p>  <p>1500/2500 RAM 94-01</p> <p>DPI 1552 / 0347 PHAR V6 3.9 V8 5.0/5.9</p> <p>PANAL: 31 5/8" X 19 3/8" X 1 1/8" CS: 2 1/2" X 20 1/4" CI: 2 1/2" X 20 1/4"</p> <p>ENTRADA: 1 1/2" SALIDA: 1 3/4"</p> <p>ENFRIADOR: SI</p> <p>013</p>	<p>A1702-28C CHRYSLER/DODGE</p>  <p>SEBRING/BREEZE/CIRRUS/STRATUS 95-00</p> <p>DPI 1702 / 2228 PHAR L4 2.0/2.4 V6 2.5</p> <p>PANAL: 24 3/8" X 14 7/8" X 1 1/8" CS: 2 1/4" X 15 1/2" CI: 2 1/4" X 15 1/2"</p> <p>ENTRADA: 1 1/4" SALIDA: 1 1/4"</p> <p>MAQ. 152 2.5 LT. V6, 2.0/2.4 LT. L4</p> <p>ENFRIADOR: NO</p> <p>014</p>	<p>A1702-28N CHRYSLER/DODGE</p>  <p>SEBRING/BREEZE/CIRRUS/STRATUS 95-00</p> <p>DPI 1702 / 2228 PHAR L4 2.0/2.4 V6 2.5</p> <p>PANAL: 24 3/8" X 14 7/8" X 1 1/8" CS: 2 1/4" X 15 1/2" CI: 2 1/4" X 15 1/2"</p> <p>ENTRADA: 1 1/4" SALIDA: 1 1/4"</p> <p>MAQ. 152 2.5 LT. V6, 2.0/2.4 LT. L4</p> <p>ENFRIADOR: NO</p> <p>015</p>
<p>A1850-28C CHRYSLER/DODGE</p>  <p>CARAVAN/VOYAGER/TOWN & COUNTRY 96-00</p> <p>DPI 1850 / 7004 PHAR L4 2.4 V6 3.0/3.3/3.8</p> <p>PANAL: 26" X 14 7/8" X 1 1/8" CS: 2 1/2" X 15 3/4" CI: 2 1/2" X 15 3/4"</p> <p>ENTRADA: 1 1/4" SALIDA: 1 1/2"</p> <p>ENFRIADOR: SI</p> <p>016</p>	<p>A1862-28C CHRYSLER/DODGE</p>  <p>CARAVAN/VOYAGER/TOWN & COUNTRY 96-00</p> <p>DPI 1862 / 2229 PHAR L4 2.4 V6 3.0/3.3/3.8</p> <p>PANAL: 25 3/4" X 15 5/8" X 1 1/8" CS: 2 1/2" X 15 3/4" CI: 2 1/2" X 15 3/4"</p> <p>ENTRADA: 1 1/4" SALIDA: 1 1/4"</p> <p>ENFRIADOR: SI (2)</p> <p>017</p>	<p>A1905-28C DODGE</p>  <p>97-00 DAKOTA/DURANGO</p> <p>PHAR 6002 / DPI 1905 V6 3.9 V8 5.2/5.9</p> <p>PANAL: 21 7/8" X 22 1/16" X 1 1/8" CAB. SUP.: 23 1/8" X 2 3/8" CAB. INF.: 23 1/8" X 2 3/8"</p> <p>ENF. TRANS.: SI ENF. MOTOR: NO</p> <p>TOMAS: ENTRADA: 1 1/2" SALIDA: 1 3/4"</p> <p>018</p>

A2183-28P4 CHRYSLER/DODGE A2184-28P4 CHRYSLER/DODGE A2196-28C CHRYSLER/DODGE

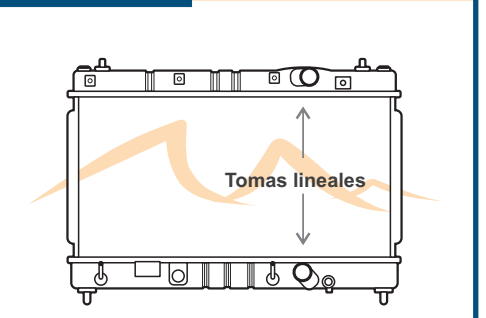
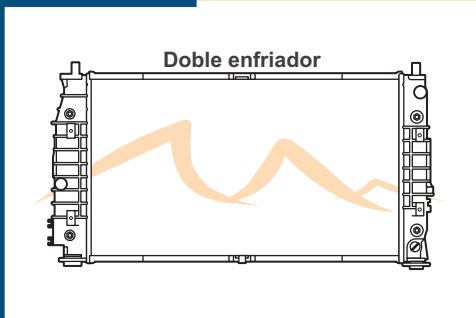
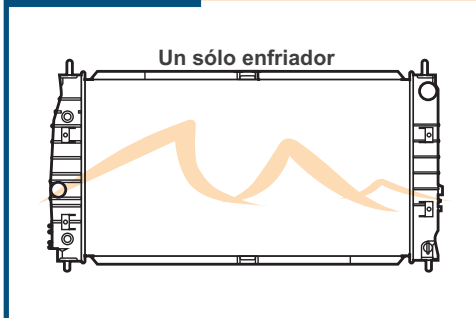

300 M/CONCORD/INTREPID 98-04
7025 PHAR V6 2.7/3.5
 PANAL: 26 9/16" X 14 1/2" X 1 1/8"
 CS: 1 5/16" X 15 5/8" ENTRADA: 1 5/16"
 CI: 1 5/16" X 15 5/8" SALIDA: 1 5/16"
 ENFRIADOR: SI 4 PLACAS
 CONDENSADOR: AC3000 **019**

300 M/CONCORD/INTREPID 98-04
DPI 2184 / 7009 PHAR V6 3.2/3.5
 PANAL: 26 5/8" X 14 13/16" X 1 1/8"
 CS: 2 1/8" X 15 3/4" ENTRADA: 1 5/16"
 CI: 2 1/8" X 15 3/4" SALIDA: 1 5/16"
 ENFRIADOR: SI
 CONDENSADOR: AC3000 **020**

NEON 95-99
DPI 2196 / 2220 PHAR L4 2.0
 PANAL: 11 3/4" X 25 1/4" X 1 1/8"
 CS: 1 15/16" X 26 1/16" ENTRADA: 1 5/16"
 CI: 1 15/16" X 26 1/16" SALIDA: 1 5/16"
 ENFRIADOR: SI **021**

A2196-28N CHRYSLER/DODGE A2291-28P6 DODGE A2294-28P5 CHRYSLER/DODGE

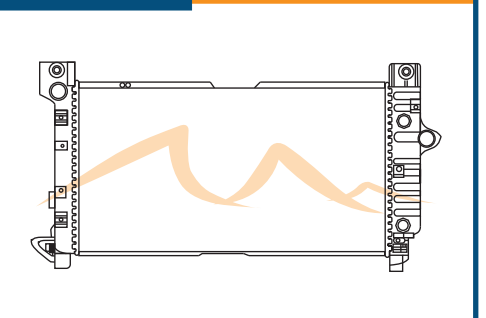
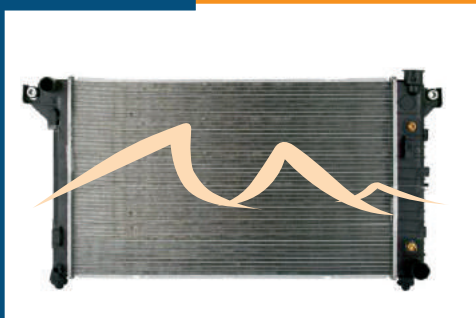
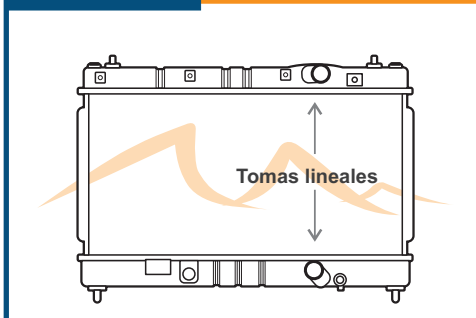

NEON 95-99
DPI 2196 / 2220 PHAR L4 2.0
 PANAL: 11 3/4" X 25 1/4" X 1 1/8"
 CS: 1 15/16" X 26 1/16" ENTRADA: 1 5/16"
 CI: 1 15/16" X 26 1/16" SALIDA: 1 5/16"
 ENFRIADOR: NO **022**

RAM 1500, 2500, 3500 97-01
V8 5.9
 PANAL: 31 3/4" X 19 3/8" X 1 1/8"
 CAB. SUP.: 20 1/8" X 2 5/16"
 CAB. INF.: 20 1/8" X 2 5/16" TOMAS:
 ENF. TRANS.: SI ENTRADA: 1 1/2"
 ENF. MOTOR: NO SALIDA: 1 3/4" **023**

DAKOTA/DURANGO 00-04
DPI 2294 / 7018 PHAR L4 2.5 V6 3.7/3.9 V8 4.7/5.9
 PANAL: 23 1/2" X 18 5/16" X 1 1/8"
 CS: 2 3/8" X 19 5/8" ENTRADA: 1 1/2"
 CI: 2 3/8" X 19 5/8" SALIDA: 1 3/4"
 ENFRIADOR: SI **024**

A2298-28C CHRYSLER/DODGE A2311-28N CHRYSLER/DODGE AT2311-28N CHRYSLER/DODGE

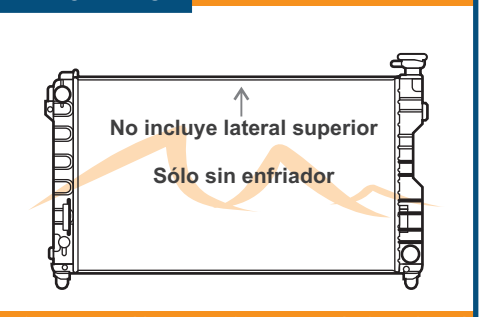
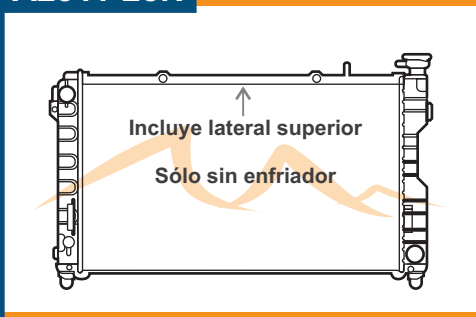
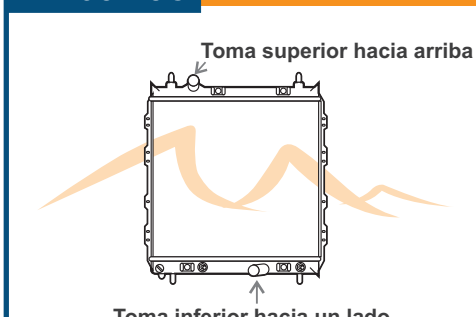

PT-CRUSIER 01-10
DPI 2298 / 7021 PHAR L4 2.4
 PANAL: 18" X 20 1/2" X 1 1/8"
 CS: 2" X 20 3/4" ENTRADA: 1 1/4"
 CI: 2" X 20 3/4" SALIDA: 1 1/4"
 ENFRIADOR: SI 757017 **025**

**CARAVAN/GRAND CARAVAN/VOYAGER/
TOWN & COUNTRY 01-04**
DPI 2311 / 7013 PHAR V6 3.3/3.8
 PANAL: 30 1/4" X 16 5/16" X 1 1/8"
 CS: 2 3/8" X 17 1/16" ENTRADA: 1 1/2"
 CI: 2 3/8" X 17 1/16" SALIDA: 1 1/2"
 ENFRIADOR: NO
 CONDENSADOR: AC4957 **026**

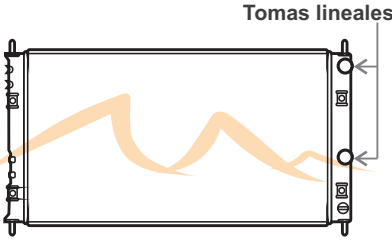
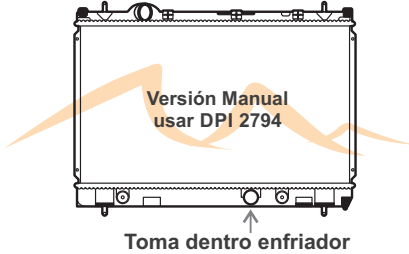
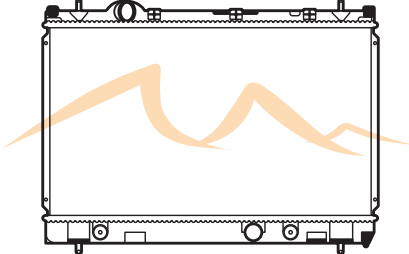
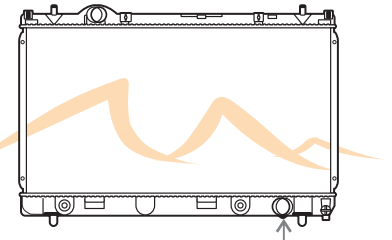
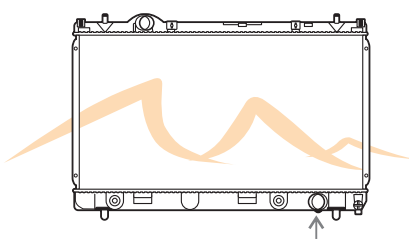
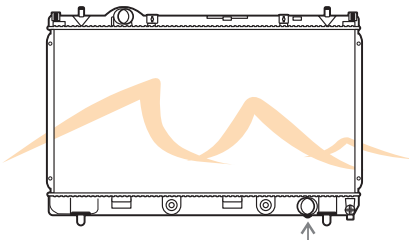
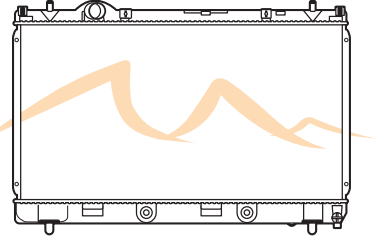
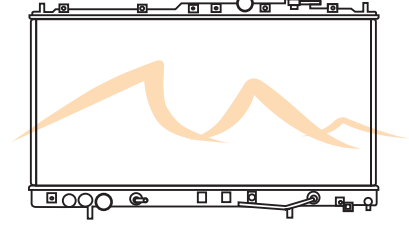
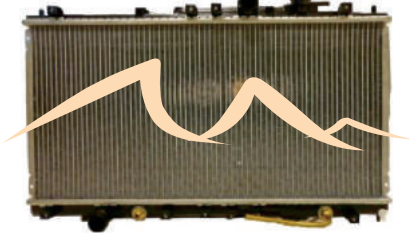

**CARAVAN/GRAND CARAVAN/VOYAGER/
TOWN & COUNTRY 01-04**
7013 PHAR V6 3.3/3.8
 PANAL: 30 1/4" X 16 5/16" X 1 1/8"
 CS: 2 3/8" X 17 1/16" ENTRADA: 1 1/2"
 CI: 2 3/8" X 17 1/16" SALIDA: 1 1/2"
 ENFRIADOR: NO
 NOTAS: SIN LATERALES (CON TANQUES) **027**

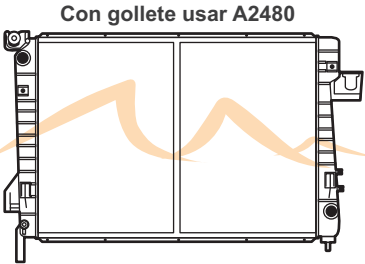
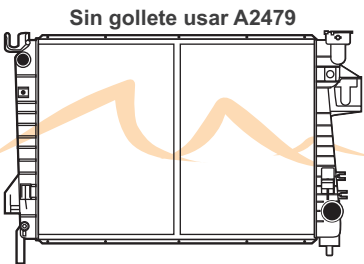
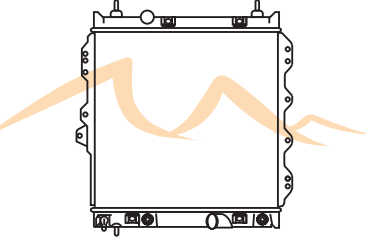
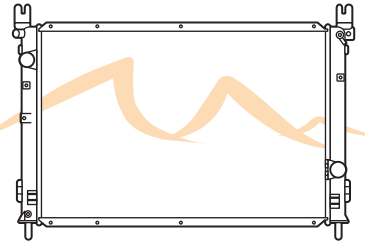
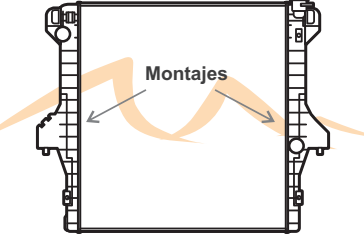
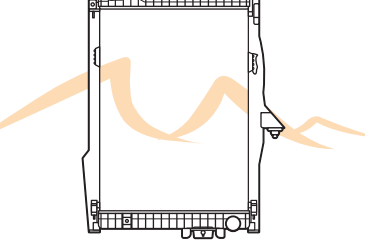
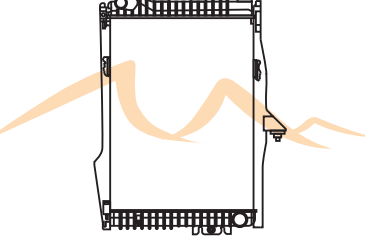
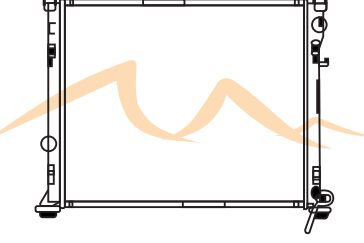
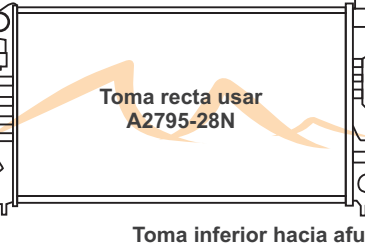
<p>A2323-28N CHRYSLER/DODGE</p>  <p>Tomas lineales</p> <p>CIRRUS/SEBRING/STRATUS 01-06</p> <p>DPI 2323 / 6121 PHAR L4 2.4 V6 2.7/3.0</p> <p>PANAL: 26 9/16" X 15 7/8" X 1 1/8" CS: 2 1/2" X 16" CI: 2 1/2" X 16"</p> <p>ENTRADA: 1 1/4" SALIDA: 1 1/4"</p> <p>ENFRIADOR: NO</p> <p>028</p>	<p>A2362-13C CHRYSLER/DODGE</p>  <p>Versión Manual usar DPI 2794</p> <p>Toma dentro enfriador</p> <p>NEON 02-04</p> <p>DPI 2362 / 6127 PHAR L4 2.0</p> <p>PANAL: 13 3/4" X 24 13/16" X 1/2" CS: 1 7/8" X 25 15/16" CI: 1 7/8" X 25 15/16"</p> <p>ENTRADA: 1 1/4" SALIDA: 1 3/8"</p> <p>ENFRIADOR: SI</p> <p>029</p>	<p>A2362-28C CHRYSLER/DODGE</p>  <p>NEON 00-04</p> <p>6127 PHAR L4 2.0</p> <p>PANAL: 13 5/8" X 25 1/8" X 1 1/8" CS: 2 1/8" X 25 7/8" CI: 2 1/8" X 25 7/8"</p> <p>ENTRADA: 1 1/4" SALIDA: 1 1/4"</p> <p>ENFRIADOR: SI</p> <p>030</p>
<p>A2363-13C CHRYSLER/DODGE</p>  <p>Toma fuera de enfriador</p> <p>SX 2.0/NEON 00-04</p> <p>DPI 2363 / 6001 PHAR L4 2.0</p> <p>PANAL: 13 5/8" X 25 1/8" X 1/2" CS: 2 1/8" X 25 7/8" CI: 2 1/8" X 25 7/8"</p> <p>ENTRADA: 1 1/4" SALIDA: 1 1/4"</p> <p>ENFRIADOR: SI</p> <p>031</p>	<p>A2363-13N CHRYSLER/DODGE</p>  <p>Toma fuera de enfriador</p> <p>SX 2.0/NEON 00-04</p> <p>DPI 2363 / 6001 PHAR L4 2.0</p> <p>PANAL: 13 5/8" X 25 1/8" X 1/2" CS: 2 1/8" X 25 7/8" CI: 2 1/8" X 25 7/8"</p> <p>ENTRADA: 1 1/4" SALIDA: 1 1/4"</p> <p>ENFRIADOR: NO</p> <p>032</p>	<p>A2363-28C CHRYSLER/DODGE</p>  <p>Toma fuera de enfriador</p> <p>SX 2.0/NEON 00-04</p> <p>DPI 2363 / 6001 PHAR L4 2.0</p> <p>PANAL: 13 5/8" X 25 1/8" X 1 1/8" CS: 2 1/8" X 25 7/8" CI: 2 1/8" X 25 7/8"</p> <p>ENTRADA: 1 1/4" SALIDA: 1 1/4"</p> <p>ENFRIADOR: SI</p> <p>033</p>
<p>A2363-26N CHRYSLER/DODGE</p>  <p>SX 2.0/NEON 00-04</p> <p>DPI 2363 / 6001 PHAR L4 2.0</p> <p>PANAL: 13 5/8" X 25 1/8" X 1 1/8" CS: 2 1/8" X 25 7/8" CI: 2 1/8" X 25 7/8"</p> <p>ENTRADA: 1 1/4" SALIDA: 1 1/4"</p> <p>ENFRIADOR: NO</p> <p>034</p>	<p>A2410-28C CHRYSLER/DODGE/MITSUBISHI</p>  <p>SEBRING/STRATUS/ECLIPSE 00-05</p> <p>DPI 2410 V6 2.7/3.0</p> <p>PANAL: 13 3/4" X 27 5/8" X 1/2" CS: 1 7/8" X 29" CI: 1 7/8" X 29"</p> <p>ENTRADA: 1 3/8" SALIDA: 1 3/8"</p> <p>EDA: SI</p> <p>035</p>	<p>A2438-28C CHRYSLER/DODGE MITSUBISHI</p>  <p>SEBRING 01-06/STRATUS 01-06/ECLIPSE 00-05</p> <p>DPI 2438 L4 2.4</p> <p>PANAL: 13 5/8" X 27 7/8" X CAB. SUP.: 1 7/8" X 28 15/16" CAB. INF.: 1 7/8" X 28 15/16"</p> <p>ENF. TRANS.: SI ENF. MOTOR: NO</p> <p>TOMAS: ENTRADA: 1 3/8" SALIDA: 1 3/8"</p> <p>036</p>

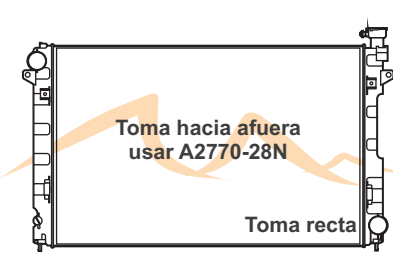
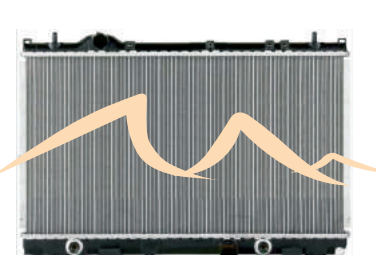
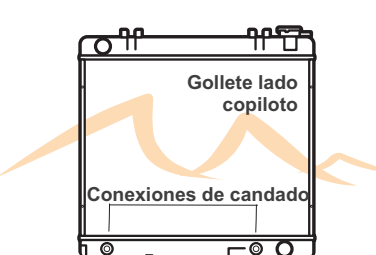
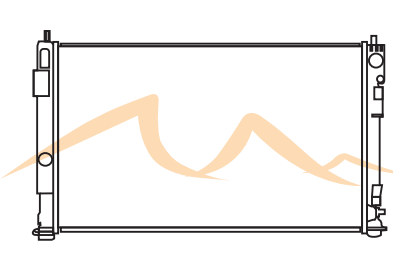
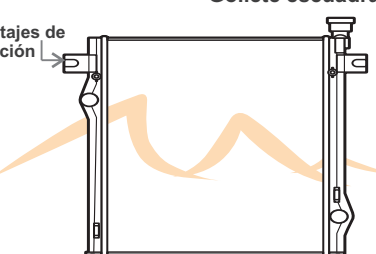
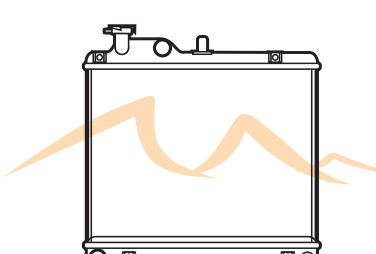
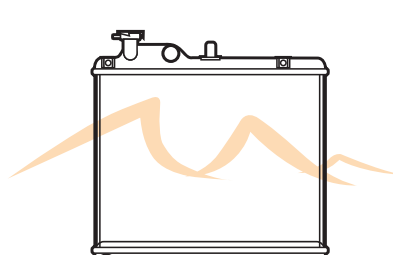
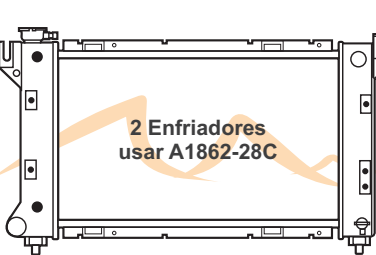
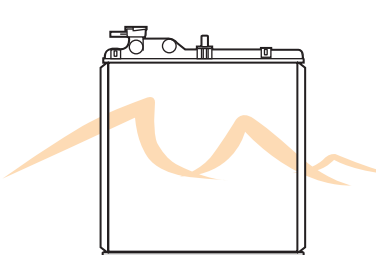
<p>A2479-44N CHRYSLER/DODGE</p>  <p>1500/2500/3500/RAM 02-04</p> <p>DPI 2479 / 7030 PHAR V6 3.7 V8 4.7/5.7</p> <p>PANAL: 24 1/8" X 19 1/8" X 1 3/4" CS: 3 1/16" X 19 5/8" CI: 3 1/16" X 19 5/8"</p> <p>ENTRADA: 1 1/2" SALIDA: 1 3/4"</p> <p>ENFRIADOR: NO</p> <p>037</p>	<p>A2480-44N CHRYSLER/DODGE</p>  <p>PICK UP RAM 02-08</p> <p>DPI 2480 / 7045 PHAR V6 3.7 V8 4.7/5.7/5.9</p> <p>PANAL: 24 1/8" X 19 1/8" X 1 3/4" CS: 3 1/16" X 19 9/16" CI: 3 1/16" X 19 9/16"</p> <p>ENTRADA: 1 1/2" SALIDA: 1 3/4"</p> <p>ENFRIADOR: NO</p> <p>038</p>	<p>A2677-28C CHRYSLER</p>  <p>PT CRUSIER 03-09</p> <p>DPI 2677 L4 2.4</p> <p>PANAL: 18" X 20 9/16" X 1 1/8" CS: 1 15/16" X 20 3/4" CI: 1 15/16" X 20 3/4"</p> <p>ENTRADA: 1 1/4" SALIDA: 1 3/8"</p> <p>ENFRIADOR: SI</p> <p>039</p>
<p>A2702-28N CHRYSLER/DODGE</p>  <p>PACIFICA 04-06</p> <p>DPI 2702 V6 3.5/3.8</p> <p>PANAL: 27 14/25" X 17 1/2" X 1 1/8" CS: 1 7/8" X 18 7/16" CI: 1 7/8" X 18 7/16"</p> <p>ENTRADA: 1 9/16" SALIDA: 1 9/16"</p> <p>ENFRIADOR: NO</p> <p>040</p>	<p>A2711-44N CHRYSLER/DODGE</p>  <p>2500/3500/4500/5500/RAM DIESEL 03-10</p> <p>DPI 2711 L6 5.9/6.7</p> <p>PANAL: 27" X 29 1/16" X 1 3/4" CS: 2 3/4" X 30 5/16" CI: 2 3/4" X 30 5/16" EDA: NO</p> <p>ENTRADA: 2 1/16" SALIDA: 2 1/16"</p> <p>041</p>	<p>A2738-44N CHRYSLER/DODGE</p>  <p>ASPEN 07-09/DURANGO 04-09</p> <p>DPI 2738 V6 3.7 V8 4.7/5.7</p> <p>PANAL: 24 1/8" X 19 1/8" X 1 3/4" CS: 2 1/2" X 20 1/2" CI: 2 1/2" X 20 1/2"</p> <p>ENTRADA: 1 3/4" SALIDA: 1 3/4"</p> <p>EDA: NO EDAM: NO</p> <p>042</p>
<p>A2739-44N DODGE</p>  <p>ASPEN/DURANGO 04-09</p> <p>DPI 2739 V6 3.8</p> <p>PANAL: 24 1/8" X 19 1/2" X 1 3/4" CS: 2 1/2" X 19 5/8" CI: 2 1/2" X 19 5/8"</p> <p>ENTRADA: 1 7/8" SALIDA: 1 7/8"</p> <p>ENFRIADOR: NO</p> <p>043</p>	<p>A2767-28N CHRYSLER/DODGE</p>  <p>300/300C/ CHARGER/MAGNUM</p> <p>DPI 2767 V6 2.7/3.5 / V8 5.7/6.1</p> <p>PANAL: 24 1/2" X 18 1/4" X 1 1/8" CS: 1 5/8" X 19 1/4" CI: 1 5/8" X 19 1/4"</p> <p>ENTRADA: 1 1/2" SALIDA: 1 1/2"</p> <p>ENFRIADOR: NO CONDENSADOR: AC3237</p> <p>044</p>	<p>A2770-28N DODGE</p>  <p>CARAVAN 05-07</p> <p>DPI 2770 L4 2.4</p> <p>PANAL: 30 5/16" X 16 1/8" X 1 1/8" CS: 2 1/16" X 17 1/4" CI: 2 1/16" X 17 1/4"</p> <p>ENTRADA: 1 1/2" SALIDA: 1 1/2"</p> <p>ENFRIADOR: NO</p> <p>045</p>

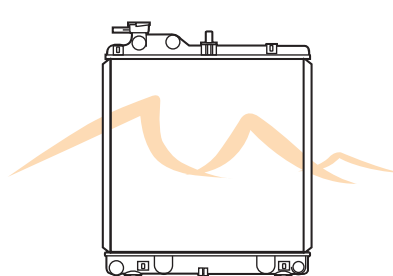
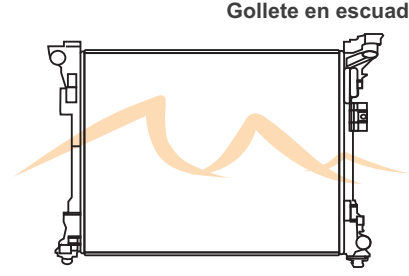
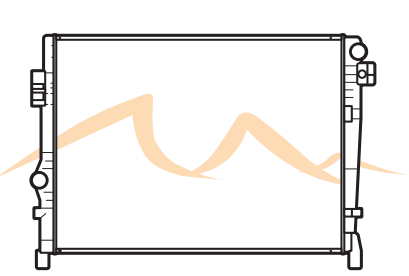
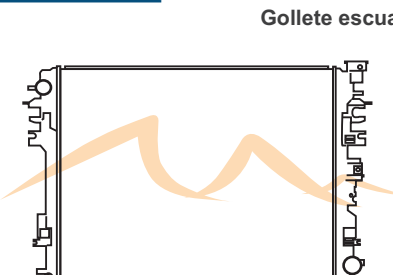
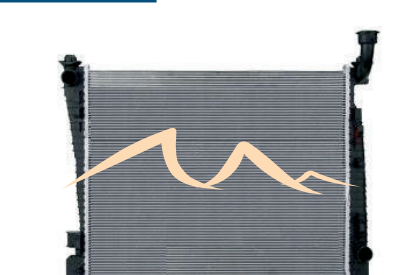
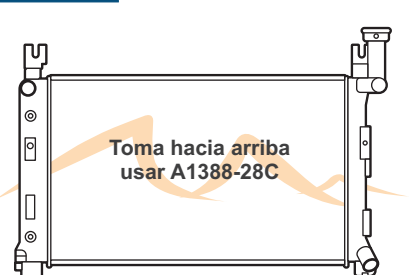
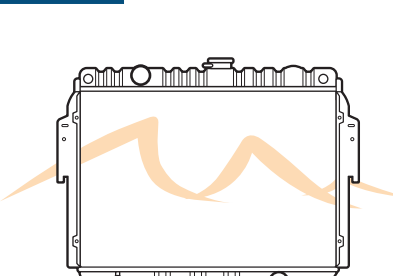
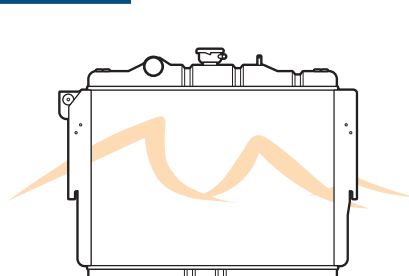
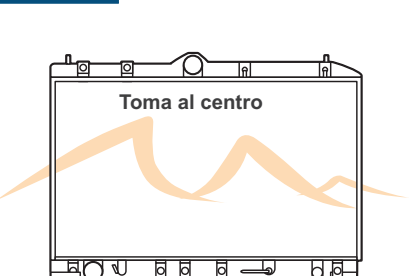
<p>A2795-28N CHRYSLER/DODGE</p>  <p>Toma hacia afuera usar A2770-28N</p> <p>Toma recta</p> <p>Montajes traseros en grapa</p> <p>TOWN & COUNTRY/VOYAGER 05-08</p> <p>DPI 2795 / 7038 PHAR V6 3.3/3.8</p> <p>PANAL: 30 1/4" X 16" X 1 1/8" CS: 2 1/16" X 17 3/16" CI: 2 1/16" X 17 3/16"</p> <p>ENTRADA: 1 1/2" SALIDA: 1 1/2"</p> <p>ENFRIADOR: NO</p> <p>046</p>	<p>A2845-28C DODGE</p>  <p>Conexiones de Candado</p> <p>NEON 2005</p> <p>DPI-2845 L4 2.0</p> <p>PANAL: 13 3/4" X 24 13/16" X 1 1/8" CS: 2 1/8" X 25 7/8" CI: 2 1/8" X 25 7/8"</p> <p>ENTRADA: 1 1/4" SALIDA: 1 3/8"</p> <p>EDA: SI 752845-M</p> <p>047</p>	<p>A2883-28C DODGE/MITSUBISHI</p>  <p>Gollete lado copiloto</p> <p>Conexiones de candado</p> <p>DAKOTA 05-11/RAIDER 06-09</p> <p>DPI 2883 / 7038 PHAR V6 3.7 V8 4.7</p> <p>PANAL: 17 3/4" X 21 1/8" X 1 1/8" CS: 1 7/8" X 22 15/16" CI: 2 13/16" X 22 15/16"</p> <p>ENTRADA: 1 9/16" SALIDA: 1 13/16"</p> <p>EDA: SI</p> <p>048</p>
<p>A2951-13N CHRYSLER/DODGE/JEEP</p>  <p>COMPASS 07-13/PATRIOT/AVENGER 07-13/CALIBER</p> <p>L4 1.8/2.0/2.4 V6 2.7/3.5/3.6</p> <p>DPI 2951</p> <p>PANAL: 27 5/8" X 16 4/5" X 1 1/8" CS: 1 13/16" X 16 11/16" CI: 1 13/16" X 16 11/16"</p> <p>ENTRADA: 1 3/8" SALIDA: 1 3/8"</p> <p>ENFRIADOR: NO CONDENSADOR: 3586</p> <p>049</p>	<p>A2971-28N CHRYSLER/DODGE</p>  <p>Gollete escuadra</p> <p>Montajes de sujeción</p> <p>NITRO 07-11</p> <p>DPI 2971 V6 3.7/4.0 M/T</p> <p>PANAL: 23 15/16" X 19 7/8" X 1" (26 mm) CS: 1 11/16" X 24 1/2" CI: 1 11/16" X 24 1/2"</p> <p>ENTRADA: 1 1/2" SALIDA: 1 3/4"</p> <p>EDA: NO</p> <p>050</p>	<p>A6031-13N CHRYSLER/DODGE</p>  <p>ATOS 01-04</p> <p>6031 PHAR L4 1.0i</p> <p>PANAL: 14" X 15 17/32" X 1/2" CS: 2" X 15 7/8" CI: 2" X 15 7/8"</p> <p>ENTRADA: 1 1/8" SALIDA: 1 1/8"</p> <p>ENFRIADOR: NO</p> <p>051</p>
<p>A6031-28N CHRYSLER/DODGE</p>  <p>ATOS 01-04</p> <p>6031 PHAR L4 1.0i</p> <p>PANAL: 14" X 15 17/32" X 1 1/8" CS: 2" X 15 7/8" CI: 2" X 15 7/8"</p> <p>ENTRADA: 1 1/8" SALIDA: 1 1/8"</p> <p>ENFRIADOR: NO</p> <p>052</p>	<p>A6118-28P6 CHRYSLER/DODGE</p>  <p>2 Enfriadores usar A1862-28C</p> <p>CARAVAN VOYAGER 96-00</p> <p>6118 PHAR L4 2.4 V6 3.8</p> <p>PANAL: 26 1/8" X 14 25/32" X 1 1/8" CS: 2 1/4" X 15 1/2" CI: 2 1/4" X 15 1/2"</p> <p>ENTRADA: 1 1/2" SALIDA: 1 1/4"</p> <p>ENFRIADOR: SI</p> <p>053</p>	<p>A7040-13N CHRYSLER/DODGE</p>  <p>ATOS 05-12</p> <p>7040 PHAR L4 1.0i</p> <p>PANAL: 16 1/16" X 15 17/32" X 1/2" CS: 1 3/4" X 16" CI: 1 3/4" X 16"</p> <p>ENTRADA: 1 1/8" SALIDA: 1 1/8"</p> <p>ENFRIADOR: NO</p> <p>054</p>

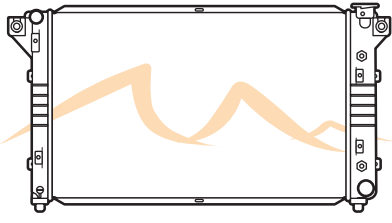
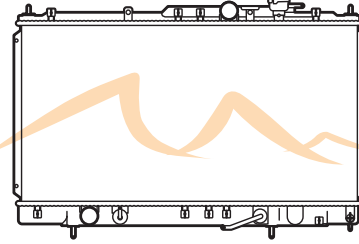
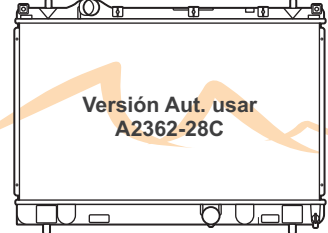
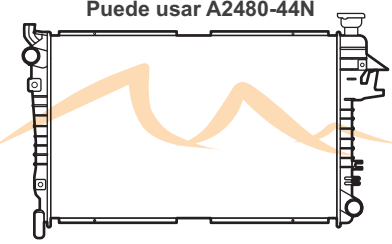
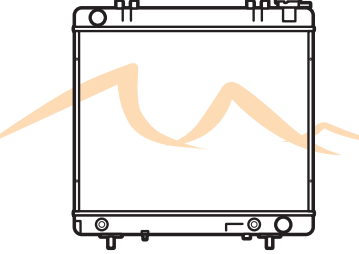
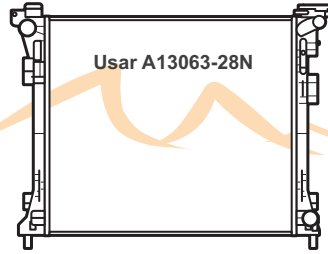
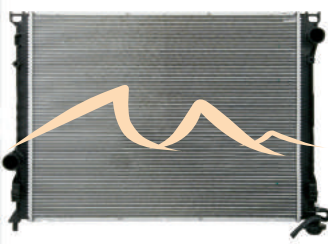
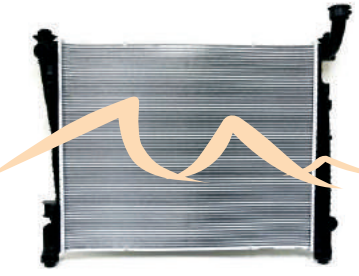
<p>A7040-28N CHRYSLER/DODGE</p>  <p>7040 PHAR L4 1.0i</p> <p>PANAL: 16 1/16" X 15 17/32" X 1 1/8" CS: 1 3/4" X 16" ENTRADA: 1 1/8" CI: 1 3/4" X 16" SALIDA: 1 1/8"</p> <p>ENFRIADOR: NO</p> <p>055</p>	<p>A13063-28N CHRYSLER</p> <p>Gollete en escuadra</p>  <p>DPI 13063 V6 3.3/3.6/3.8/4.0</p> <p>PANAL: 24 1/8" X 21 4/9" X 1 1/8" CS: 2 5/16" X 21 7/8" ENTRADA: 1 1/2" CI: 2 5/16" X 21 7/8" SALIDA: 1 1/2"</p> <p>ENFRIADOR: NO CONDENSADOR: AC3682</p> <p>056</p>	<p>A13084-13N DODGE</p>  <p>DPI 13084 L4 2.4 V6 3.5/3.6</p> <p>PANAL: 25 1/16" X 18" X 1/2" CS: 1 1/4" X 18 13/16" ENTRADA: 1 3/8" CI: 1 1/4" X 18 13/16" SALIDA: 1 3/8"</p> <p>EDA: NO</p> <p>057</p>
<p>A13129-28N DODGE</p> <p>Gollete escuadra</p>  <p>DPI 13129 V6 3.6/3.7 V8 4.7/5.7</p> <p>PANAL: 27 1/2" X 21 7/8" X 1 1/8" CS: 2" X 23 1/16" ENTRADA: 1 1/2" CI: 2" X 23 1/16" SALIDA: 1 3/4"</p> <p>ENF. TRANS.: NO</p> <p>058</p>	<p>A13200-13N DODGE/JEEP</p>  <p>DPI-13200 V6 3.6 / V8 5.7/6.4</p> <p>PANAL: 25 1/16" X 20 9/16" X 1/2" CAB: SUP.: 1 5/8" X 21 5/8" ENTRADA: 1 1/2" CAB: INF.: 1 5/8" X 21 5/8" SALIDA: 1 1/2"</p> <p>ENFRIADOR: NO CONDENSADOR: AC3893</p> <p>059</p>	<p>1392 DPI CHRYSLER/DODGE</p> <p>Toma hacia arriba usar A1388-28C</p>  <p>Toma hacia abajo</p> <p>2230 PHAR V6 3.0</p> <p>PANAL: 25 5/8" X 15" X 1 1/2" CS: 2 3/8" X 15 5/8" ENTRADA: 1 1/4" CI: 2 3/8" X 15 5/8" SALIDA: 1 1/4"</p> <p>EDA: 12" 5 PLACAS EDAM: NO</p> <p>060</p>
<p>1707 DPI CHRYSLER/DODGE</p>  <p>DPI 1707 / 0399 PHAR V6 3.9 V8 5.6/5.9</p> <p>PANAL: 18 3/4" X 27 1/4" X 1 1/2" CS: 2" X 27 1/4" ENTRADA: 1 1/2" CI: 2" X 27 1/4" SALIDA: 1 3/4"</p> <p>EDA: S1 EDAM: NO</p> <p>061</p>	<p>1709 DPI CHRYSLER/DODGE</p>  <p>DPI 1709 V6 3.9 V8 5.2</p> <p>PANAL: 17 5/8" X 25 5/8" X 1 1/2" CS: 2 1/2" X 26 1/4" ENTRADA: 1 1/2" CI: 2 1/2" X 26 1/4" SALIDA: 1 3/4"</p> <p>EDA: 14 3/8" EDAM: NO</p> <p>062</p>	<p>1892 DPI CHRYSLER/DODGE</p> <p>Toma al centro</p>  <p>DPI 1892 V6 2.5</p> <p>PANAL: 13 3/4" X 26 3/4" X 1" (26 mm) CS: 2" X 27 1/2" ENTRADA: 1 3/8" CI: 2" X 27 1/2" SALIDA: 1 3/8"</p> <p>EDA: S1</p> <p>063</p>

<p>2291 DPI CHRYSLER/DODGE</p>  <p>RAM 98-02</p> <p>0397 PHAR V8 5.9</p> <p>PANAL: 31 5/8" X 19 3/16" X 1 1/4" (32 mm) CS: 2 9/16" X 20 1/4" ENTRADA: 1 1/2" CI: 2 9/16" X 20 1/4" SALIDA: 1 3/4" EDA: 12" 6 PLACAS EDAM: NO</p> <p>064</p>	<p>2438 DPI CHRYSLER/DODGE/ MITSUBISHI</p>  <p>SEBRING/STRATUS 01-06/ECLIPSE 01-05</p> <p>L4 2.4</p> <p>PANAL: 13 3/4" X 28 1/4" X 1" (26 mm) CS: 1 7/8" X 28 5/16" ENTRADA: 1 3/8" CI: 1 7/8" X 28 5/16" SALIDA: 1 3/8" EDA: SI Concéntrico</p> <p>065</p>	<p>2794 DPI CHRYSLER/DODGE</p>  <p>Versión Aut. usar A2362-28C</p> <p>NEON M/T 03-05</p> <p>L4 2.4</p> <p>PANAL: 13 5/8" X 25 1/4" X 1" (26 mm) CS: 1 7/8" X 25 15/16" ENTRADA: 1 5/16" CI: 1 7/8" X 25 15/16" SALIDA: 1 5/16" EDA: NO EDAM: NO</p> <p>066</p>
<p>2813 DPI CHRYSLER/DODGE</p>  <p>Puede usar A2480-44N</p> <p>RAM 04-09</p> <p>7045 PHAR V8 5.7</p> <p>PANAL: 24 1/8" X 19 1/8" X 1 5/8" CS: 2 1/2" X 20 1/2" ENTRADA: 1 1/2" CI: 2 1/2" X 20 1/2" SALIDA: 1 1/2" EDA: SI</p> <p>067</p>	<p>2847 DPI CHRYSLER/DODGE</p>  <p>DAKOTA 05-07</p> <p>V6 3.7</p> <p>PANAL: 17 11/16" X 21 7/8" X 1 1/16" CS: 1 7/8" X 22 15/16" ENTRADA: 1 9/16" CI: 2 3/16" X 22 15/16" SALIDA: 1 13/16" EDA: SI Concéntrico</p> <p>068</p>	<p>13064 DPI CHRYSLER/DODGE</p>  <p>Usar A13063-28N</p> <p>CARAVAN/GRAND CARAVAN 08-09</p> <p>L4 2.0/ L6 2.5/3.0</p> <p>PANAL: 24 1/8" X 20 1/2" X 1 1/4" (32 mm) CS: 21 1/2" X 2" ENTRADA: 1 1/2" CI: 21 1/2" X 2" SALIDA: 1 1/2" Enfriador: NO</p> <p>069</p>
<p>13157 DPI CHRYSLER/DODGE</p>  <p>Montajes para condensador atrás</p> <p>300/CHALLENGER/CHARGER 09-15</p> <p>DPI 13157 V6 2.7/3.5/3.7 / V8 5.7/6.1</p> <p>PANAL: 24 1/8" X 18 1/2" X 1" CAB. SUP.: 1 3/16" X 19 1/8" CAB. INF.: 1 3/16" X 19 1/8" Enfriador: NO</p> <p>TOMAS: ENTRADA: 1 1/2" SALIDA: 1 1/2"</p> <p>CONDENSADOR: AC3897</p> <p>070</p>	<p>13200 DPI DODGE/JEEP</p>  <p>DURANGO/GRAND CHEROKEE 11-15</p> <p>V6 3.6 V8 5.7/6.4</p> <p>PANAL: 25 1/16" X 20 9/16" X 1" CS: 1 3/4" X 21 5/8" ENTRADA: 1 1/2" CI: 1 3/4" X 21 5/8" SALIDA: 1 1/2" EDA: NO EDAM: NO</p> <p>071</p>	<p>13252 DPI DODGE/HYUNDAI</p>  <p>ATTITUD/ACCENT-VELOSTER/KIA RIO 12-16</p> <p>L3 1.2 / L4 1.4/1.6</p> <p>PANAL: 19 11/16" X 14 1/2" X 5/8" CAB. SUP.: 1 7/16" X 15 7/8" CAB. INF.: 1 7/16" X 15 7/8" Enfriador: NO</p> <p>TOMAS: ENTRADA: 1 3/8" SALIDA: 1 5/16"</p> <p>072</p>

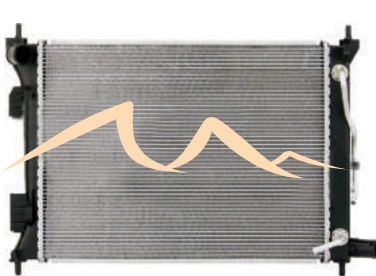
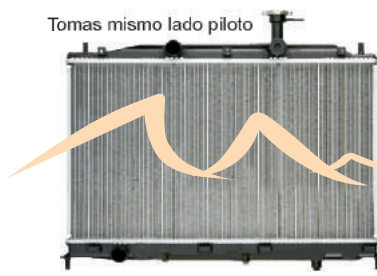
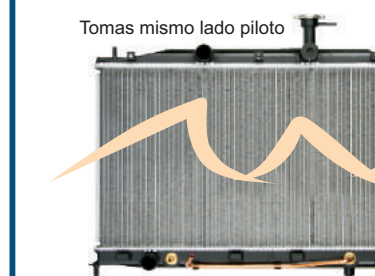
13253 DPI DODGE/HYUNDAI	2896 DODGE/HYUNDAI	2896-2 DODGE/HYUNDAI
	Tomas mismo lado piloto  Gollete en escuadra	Tomas mismo lado piloto  Gollete en escuadra
ATTITUDE/ACCENT/KIA RIO 12-16 L3 1.2 / L4 1.4/1.6	ATTITUDE/VERNA/ACCENT 06-10 L4 1.5/1.6	ATTITUDE/VERNA/ACCENT 06-10 L4 1.5/1.6
PANAL: 19 11/16" X 14 1/2" X 5/8" CAB. SUP.: 1 15/16" X 15 7/16" CAB. INF.: 1 15/16" X 15 7/16" Enfriador: NO	PANAL: 14 9/16" X 25 3/8" X 5/8" (16mm) CAB. SUP.: 1 13/16" X 25 7/8" CAB. INF.: 1 13/16" X 25 7/8" ENF. TRANS.: SI ENF. MOTOR: NO	PANAL: 14 9/16" X 25 3/8" X 5/8" (16mm) CAB. SUP.: 1 13/16" X 25 7/8" CAB. INF.: 1 13/16" X 25 7/8" ENF. TRANS.: NO ENF. MOTOR: NO
TOMAS: ENTRADA: 1 3/8" SALIDA: 1 15/16"	TOMAS ENTRADA: 1 3/8" SALIDA: 1 3/8"	TOMAS ENTRADA: 1 3/8" SALIDA: 1 3/8"
073	074	075

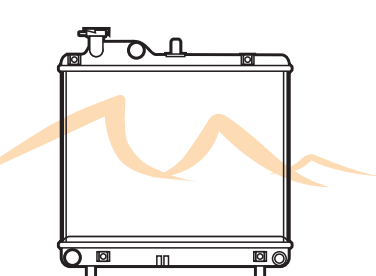
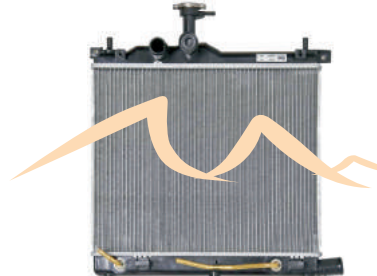
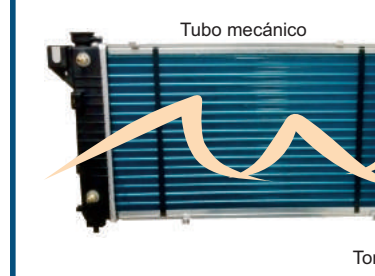
LHRP0158-26MT CHRYSLER/DODGE	LHRP589-1 DODGE/HYUNDAI	M1850-26C DODGE/CHRYSLER
		Tubo mecánico  Tomas lineales
ATOS 00-04 V6 3.8	GRAND I10 15-16 1.0/1.6	GRAND VOYAGER/TOWN COUNTRY/ CARAVAN/VOYAGER 96-00 L4 2.4 / V6 3.0/3.3/3.8
PANAL: 14" X 15 17/32" X 7/8" (22 mm) CS: 2" X 15 7/8" CI: 2" X 15 7/8" EDA: NO EDAM:	PANAL: 13 3/4" X 17 1/4" X 1" CAB. SUP.: 1 13/16" X 17 25/32" CAB. INF.: 1 13/16" X 17 25/32" Enfriador: SI	PANAL: 25 13/16" X 14 7/8" X 1" CS: 2 11/16" X 15 15/16" CI: 2 11/16" X 15 15/16" EDA: SI
ENTRADA: 1 1/8" SALIDA: 1 1/8"	TOMAS: ENTRADA: 1 1/8" SALIDA: 1 1/8"	ENTRADA: 1 5/16" SALIDA: 1 9/16"
076	077	078

M1862-26C CHRYSLER	M2311-26N CHRYSLER	M2362-26C CHRYSLER/DODGE
Tomas encontradas dos enfriadores  Tubo mecánico	Completo con laterales  Aluminio Mecánico	Versión M/T usar DPI 2794 Aluminio Mecánico  Conexiones de espiga Toma dentro de enfriador
CARAVAN/VOYAGUER/TOWN COUNTRY 96-00 DPI 1862 L4 2.4 / V6 3.0/3.3/3.8	CARAVAN/GRAND CARAVAN/VOYAGUER/TOWN&COUNTRY 01-04 DPI 2311 / 7013 PHAR V6 3.3/3.8	SX 2.0/NEON 00-04 DPI 2362 / 6127 PHAR L4 2.0
PANAL: 26 1/8" X 14 1/8" X 1" CAB. SUP.: 2 3/8" X 15 11/16" CAB. INF.: 2 3/8" X 15 11/16" ENF. MOTOR: SI	PANAL: 30 5/16" X 15 3/4" X 1" CAB. SUP.: 2 1/2" X 17 1/4" CAB. INF.: 2 1/2" X 17 1/4" ENFRIADOR: NO	PANAL: 13 5/8" X 24 7/8" X 1" CAB. SUP.: 25 15/16" X 1 7/8" CAB. INF.: 25 15/16" X 1 7/8" ENFRIADOR: SI
TOMAS: ENTRADA: 1 1/4" SALIDA: 1 1/2"	TOMAS: ENTRADA: 1 1/2" SALIDA: 1 1/2"	TOMAS: ENTRADA: 1 5/16" SALIDA: 1 5/16"
079	080	081

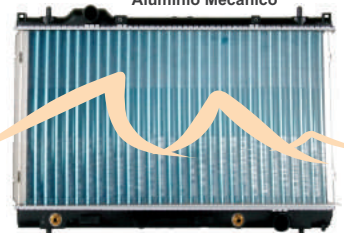
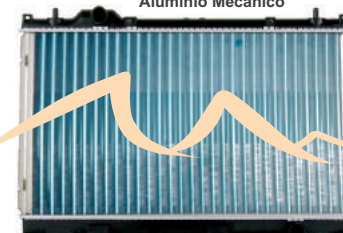
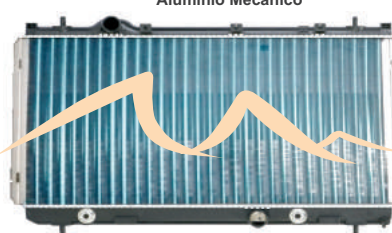
M2363-26C	CHRYSLER	M2363-26N	CHRYSLER	M2845-26C	CHRYSLER
Aluminio Mecánico		Aluminio Mecánico		Aluminio Mecánico	
					
Conexiones tipo espiga Toma en la orilla		Sin enfriador		Conexiones de candado	
NEON 00-04/ SX 2.0 03-04		NEON 00-04/SX 2.0 03-04		NEON/SX 2.0 2005	
DPI 2363 / 6001 PHAR		DPI 2363 / 6001 PHAR		DPI 2845	
L4 2.0		L4 2.0		L4 2.0	
PANAL: 13 5/8" X 24 7/8" X 1" CAB. SUP.: 25 15/16" X 1 7/8" CAB. INF.: 25 15/16" X 1 7/8" ENFRIADOR: SI		PANAL: 13 5/8" X 24 7/8" X 1" CAB. SUP.: 25 15/16" X 1 7/8" CAB. INF.: 25 15/16" X 1 7/8" ENFRIADOR: NO		PANAL: 13 5/8" X 24 7/8" X 1" CAB. SUP.: 25 15/16" X 1 7/8" CAB. INF.: 25 15/16" X 1 7/8" ENFRIADOR: SI	
TOMAS: ENTRADA: 1 5/16" SALIDA: 1 5/16"		TOMAS: ENTRADA: 1 5/16" SALIDA: 1 5/16"		TOMAS: ENTRADA: 1 5/16" SALIDA: 1 5/16"	
082		083		084	

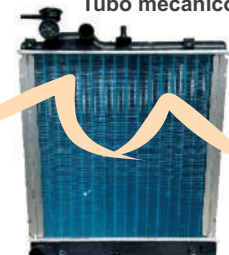
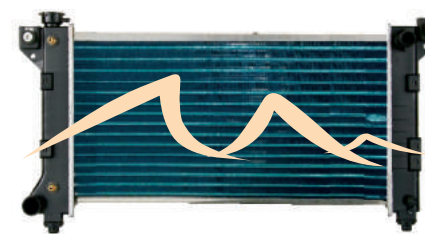
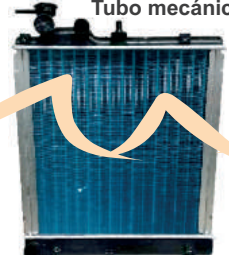
M6031-26N	CHRYSLER	M6118-26C	CHRYSLER	M7040-26N	CHRYSLER
Tubo mecánico		Tubo mecánico		Tubo mecánico	
					
ATOS 01-04		VOYAGUER/TOWN & COUNTRY/CARAVAN 96-00		ATOS 05-12	
L4 1.0i		L4 2.4 / V6 3.8		L4 1.0i	
PANAL: 14" X 15" X 1" CAB. SUP.: 1 3/4" X 16" CAB. INF.: 1 3/4" X 16" ENF. MOTOR: NO		PANAL: 26 1/8" X 14 1/8" X 1" CAB. SUP.: 2 3/8" X 15 11/16" CAB. INF.: 2 3/8" X 15 11/16" ENF. MOTOR: NO		PANAL: 16 1/16" X 15" X 1" CAB. SUP.: 1 3/4" X 16" CAB. INF.: 1 3/4" X 16" ENF. MOTOR: NO	
TOMAS: ENTRADA: 1 1/8" SALIDA: 1 1/8"		TOMAS: ENTRADA: 1 1/4" SALIDA: 1 1/2"		TOMAS: ENTRADA: 1 1/8" SALIDA: 1 1/8"	
085		086		087	

MT2311-26N **CHRYSLER**

No incluye laterales



Aluminio Mecánico

CARAVAN/GRAND CARAVAN/VOYAGUER/TOWN&COUNTRY 01-04

DPI 2311 / 7013 PHAR **V6 3.3/3.8**

PANAL: 30 5/16" X 15 3/4" X 1"
 CAB. SUP.: 2 1/2" X 17 1/4"
 CAB. INF.: 2 1/2" X 17 1/4"
 ENFRIADOR: NO

TOMAS:
ENTRADA: 1 1/2"
SALIDA: 1 1/2"

088

My
PHAR

www.phar.com.mx

**PRUEBA NUESTRA
VERSION IMPRESA
EN LINEA**



www.phar.com.mx

NOTAS

Large lined area for notes, with a decorative orange wave graphic at the bottom.

Radiadores

PHAR

- **CITROEN**
- **DAEWOO**
- **FIAT**

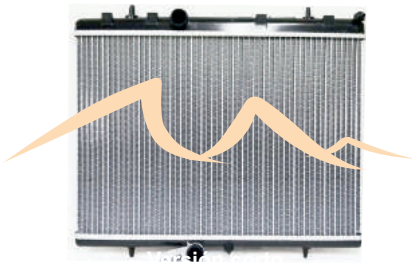
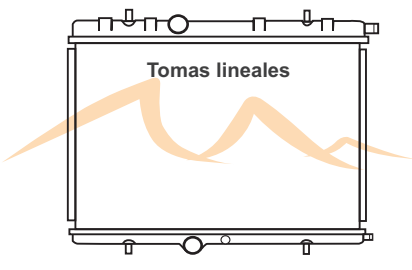
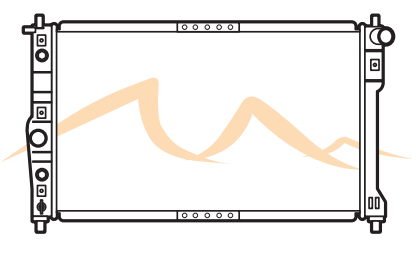
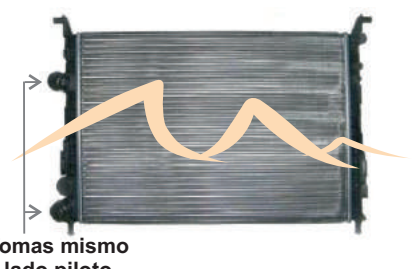
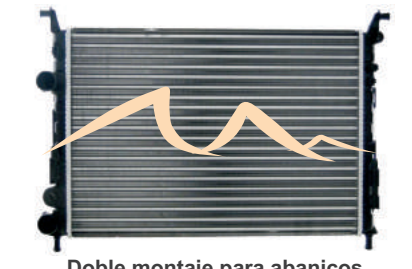
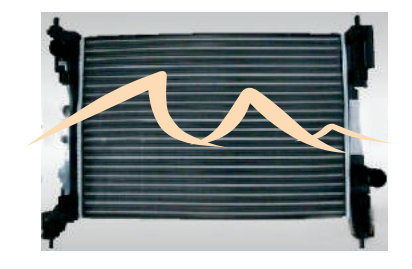
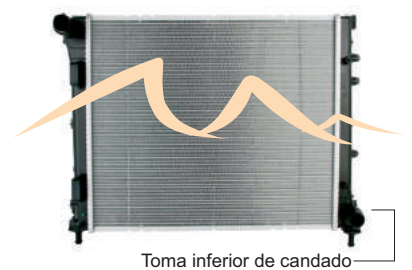
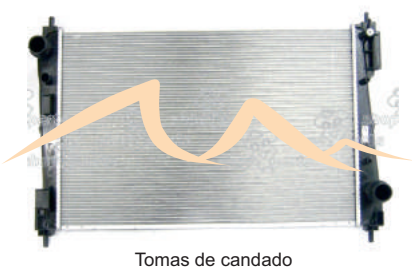
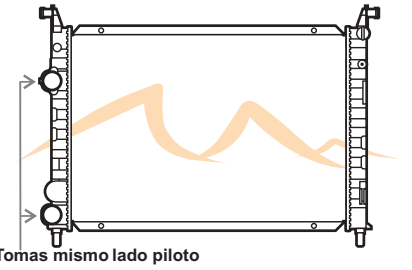
<p>LHRP289 CITROEN/PEUGEOT</p>  <p>307/C4 00-08 L4 1.6/1.8/2.0</p> <p>PANAL: 14 7/8" X 21 9/16" X 1" (26mm) CS: 1 11/16" X 22 3/16" CI: 1 11/16" X 22 3/16" EDA: NO</p> <p>ENTRADA: 1 1/4" SALIDA: 1 1/4"</p> <p>001</p>	<p>LHRP291 CITROEN/PEUGEOT</p>  <p>206/C4 2004 MT L4 1.6</p> <p>PANAL: 14 7/8" X 21 9/16" X 1" (26mm) CS: 1 11/16" X 22 3/16" CI: 1 11/16" X 22 3/16" EDA: NO</p> <p>ENTRADA: 1 1/4" SALIDA: 1 1/4"</p> <p>002</p>	<p>2384 DPI DAEWOO</p>  <p>LEGANZA/NUBIRA 1999 L4 2.0/2.2</p> <p>PANAL: 25 3/4" X 15" X 5/8" (16 mm) CS: 1 9/16" X 15 3/4" CI: 1 9/16" X 15 3/4" EDA: SI Concéntrico</p> <p>ENTRADA: 1 3/8" SALIDA: 1 3/8"</p> <p>003</p>
<p>A010-13N FIAT</p>  <p>PALIO ADVENTURE 05 1.6/1.8 16V</p> <p>PANAL: 20 5/8" X 14 3/4" X 1/2" CS: 1 7/8" X 14 15/16" CI: 1 7/8" X 14 15/16"</p> <p>ENTRADA: 1 3/8" SALIDA: 1 3/8"</p> <p>ENFRIADOR: NO</p> <p>004</p>	<p>A035-13N FIAT</p>  <p>PALIO ADVENTURE 05-07 1.6/1.8 16V</p> <p>PANAL: 20 5/8" X 13 7/8" X 1/2" CAB. SUP.: 15 3/8" X 1 11/16" CAB. INF.: 15 3/8" X 1 11/16" ENFRIADOR: NO</p> <p>TOMAS: ENTRADA: 1 3/8" SALIDA: 1 3/8"</p> <p>005</p>	<p>LHRP437 FIAT</p>  <p>PUNTO 00-05 L4 1.2/1.4 M-T</p> <p>PANAL: 21 1/4" X 13 5/8" X 1" (26) CS: 19/16" X 14 13/16" CI: 19/16" X 14 13/16"</p> <p>ENTRADA: 1 1/2" SALIDA: 1 1/2"</p> <p>EDA: NO</p> <p>006</p>
<p>LHRP793 FIAT</p>  <p>PANDA 12-15 L4 1.4i</p> <p>PANAL: 19" X 15 5/8" X 1" (26) CS: 1 5/8" X 16 1/2" CI: 1 5/8" X 16 1/2" EDA: NO</p> <p>ENTRADA: 1 1/4" SALIDA: 1 1/4"</p> <p>007</p>	<p>LHRP15010 FIAT</p>  <p>PUNTO III/GRANDE 05-08 1.3</p> <p>PANAL: 24 3/8" X 15 5/8" X 1" (26) CS: 1 11/16" X 16 1/2" CI: 1 11/16" X 16 1/2" EDA: NO</p> <p>ENTRADA: 1 1/2" SALIDA: 1 1/2"</p> <p>008</p>	<p>LHRP0133-16MT FIAT</p>  <p>PALIO 2004 1.2 i</p> <p>PANAL: 20 7/16" X 13 11/16" X 5/8" (16 mm) CS: 1 11/16" X 14 15/16" CI: 1 11/16" X 14 15/16" EDA: NO EDAM:</p> <p>ENTRADA: 1 7/16" SALIDA: 1 7/16"</p> <p>009</p>

FT0020-24M

FIAT

ALUMINIO MECÁNICO



PALIO 05-07

FT 0020

1.6/1.8 16V

PANAL: 20 5/8" X 14 7/8" X 7/8"

CS: 14 7/8" X 1 3/4"

CI: 14 7/8" X 1 3/4"

EDA: NO

ENTRADA: 1 3/8"

SALIDA: 1 3/8"

010

My
PHAR

www.phar.com.mx

**PRUEBA NUESTRA
VERSION IMPRESA
EN LINEA**

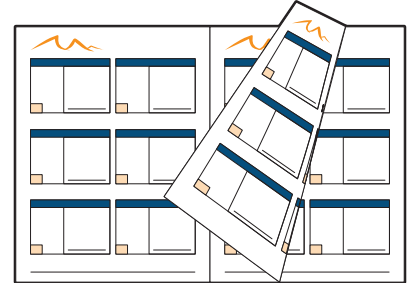

www.phar.com.mx

NOTAS





NOTAS

A large rectangular area with a light orange background and a dark blue border, containing horizontal lines for taking notes. At the bottom of this area, there is a stylized orange graphic element resembling a mountain range or a waveform.

Radiadores

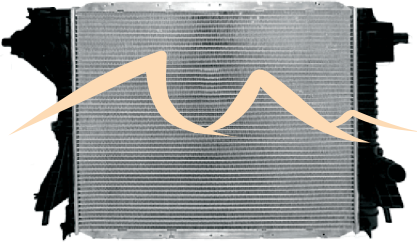
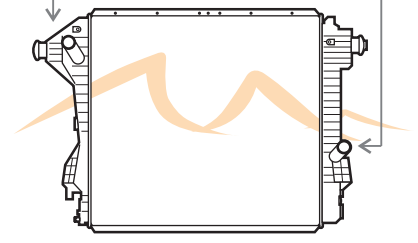
PHAR

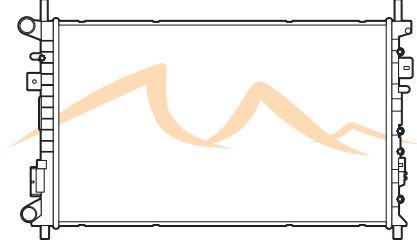
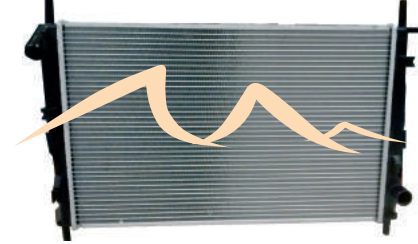
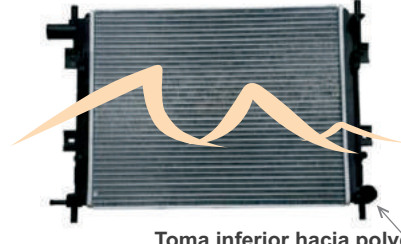
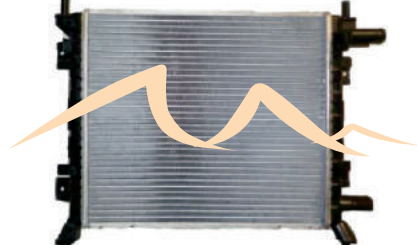
- **FORD**
- **FREIGHTLINER**

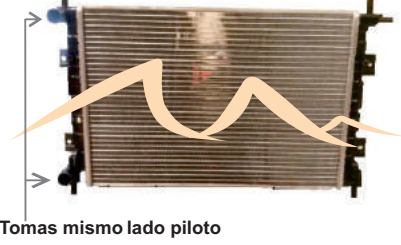
<p>A006-28N FORD</p> <p>Tomas de candado</p>  <p>F-350 CAMIÓN GASOLINA SUPER DUTY 08-13</p> <p>Aleta 5mm V8 5.4/6.2 V10 6.8</p> <p>PANAL: 30 1/2" X 26 3/4" X 1 1/8" CAB. SUP.: 1 7/8" X 27 3/4" ENTRADA: 1 13/16" CAB. INF.: 3 1/16" X 27 3/4" SALIDA: 1 13/16" ENFRIADOR: NO 06/15</p> <p>001</p>	<p>A006-28N FORD</p> <p>Tomas de candado</p>  <p>F-350 CAMION GASOLINA SUPER DUTY 08-13</p> <p>Aleta 8mm V8 5.4/6.2 V10 6.8</p> <p>PANAL: 30 3/8" X 27 1/8" X 1 1/8" CS: 1 7/8" X 27 3/4" ENTRADA: 1 13/16" CI: 3 1/4" X 27 3/4" SALIDA: 1 17/8" ENFRIADOR: NO</p> <p>002</p>	<p>A008-13N FORD</p> <p>Tomas mismo lado piloto</p>  <p>ECO-SPORT 03-09 / FIESTA 04-09</p> <p>L4 2.0 16V</p> <p>PANAL: 22" X 14 1/4" X 1/2" CS: 1 5/8" X 14 3/16" ENTRADA: 1 1/16" CI: 1 5/8" X 14 3/16" SALIDA: 1 1/16" ENFRIADOR: NO</p> <p>003</p>
<p>A008-28N FORD</p>  <p>FIESTA 04/ECO SPORT 03-06</p> <p>L4 1.6/2.0</p> <p>PANAL: 22" X 14 1/8" X 1 1/8" CS: 1 5/8" X 14 3/16" ENTRADA: 1 1/16" CI: 1 5/8" X 14 3/16" SALIDA: 1 1/16" ENFRIADOR: NO</p> <p>004</p>	<p>A011-28N FORD</p>  <p>MONDEO 2003</p> <p>L4 1.8/2.6</p> <p>6231 PHAR</p> <p>PANAL: 24 5/8" X 15 9/16" X 1 1/8" CS: 2 1/2" X 16" ENTRADA: 1 1/4" CI: 2 1/2" X 16" SALIDA: 1 1/4" ENFRIADOR: NO</p> <p>005</p>	<p>A013-28N FORD</p>  <p>Toma inferior hacia polvera</p> <p>IKON/FIESTA 03-07</p> <p>L4 1.6</p> <p>PA-800</p> <p>PANAL: 19 3/4" X 15 3/16" X 1 1/8" CS: 1 7/8" X 15 3/16" ENTRADA: 1 1/4" CI: 1 7/8" X 15 3/16" SALIDA: 1 1/4" ENFRIADOR: NO</p> <p>006</p>
<p>A026-28N FORD</p>  <p>KA 00-07</p> <p>L4 1.3/1.4 CA/C M/T</p> <p>PANAL: 15" X 13 1/2" X 1 1/8" CAB. SUP.: 14 11/32" X 1 13/16" CAB. INF.: 14 11/32" X 1 13/16" ENF. TRANS.: NO TOMAS: ENF. MOTOR: NO ENTRADA: 1" SALIDA: 1"</p> <p>007</p>	<p>AA0033-44C FORD</p> <p>Versión todo en aluminio</p>  <p>Tomas invertidas</p> <p>BRONCO 66-77</p> <p>L6 2.8/3.3 V8 4.7/5.0</p> <p>DPI 521 / 8225 PHAR</p> <p>PANAL: 18 7/8" x 18 15/16" x 1 3/4" CS: 19 1/8" X 2 7/16" ENTRADA: 1 1/2" CI: 19 1/8" X 2 7/16" SALIDA: 1 3/4" ENFRIADOR: SI 756348-M 02/15</p> <p>008</p>	<p>A036-28N FORD</p>  <p>Tomas mismo lado piloto</p> <p>COURIER 93-09</p> <p>L4 1.6/2.0</p> <p>LHRP703</p> <p>PANAL: 19 5/8" X 13 5/8" X 1 1/8" CS: 1 11/16" X 14 13/16" ENTRADA: 1 1/16" CI: 1 11/16" X 14 13/16" SALIDA: 1 1/16" ENFRIADOR: NO</p> <p>009</p>

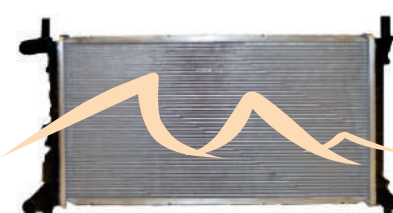
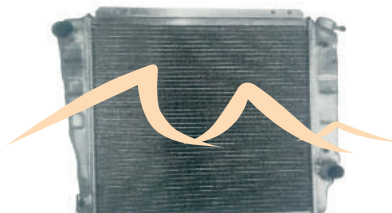
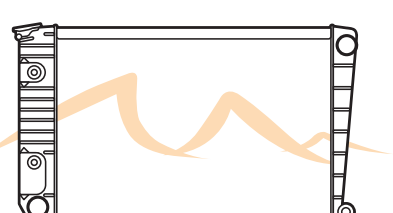
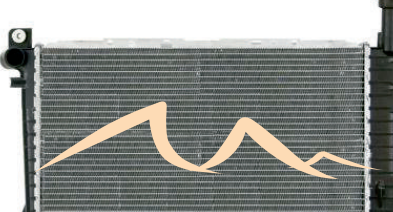
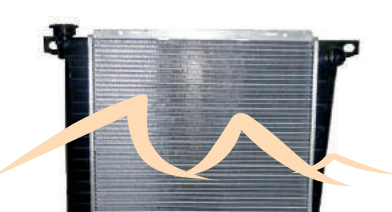
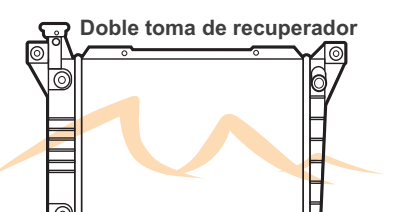
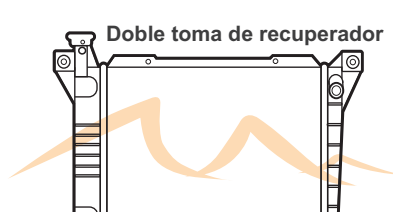
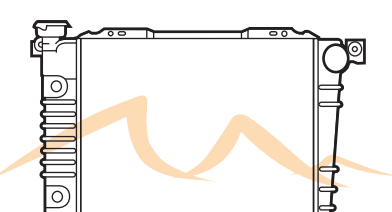
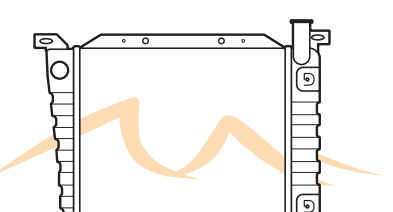

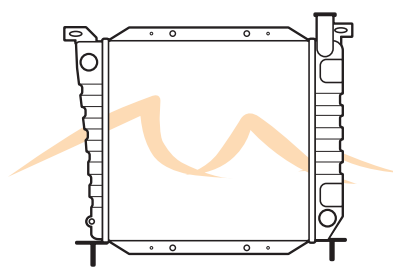
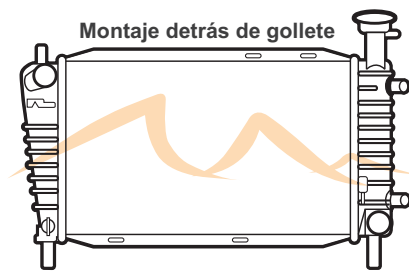
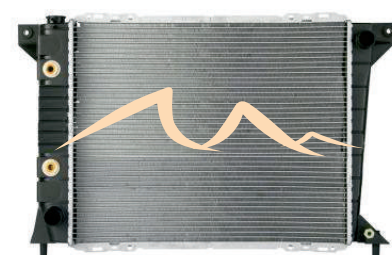
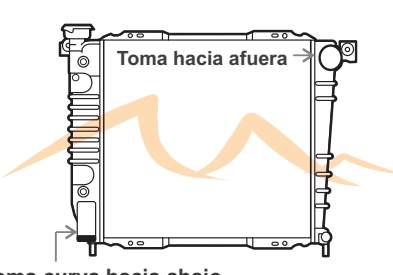
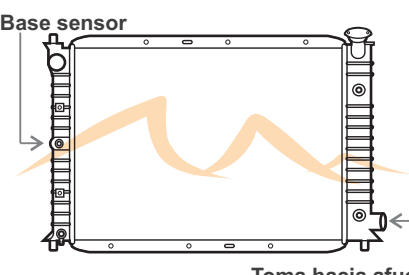
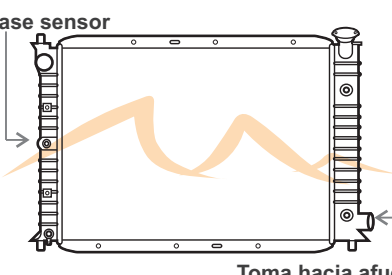
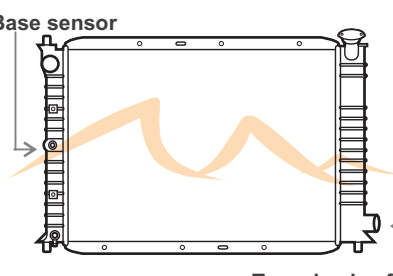
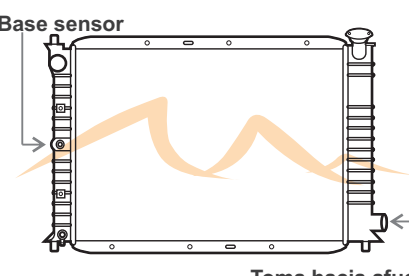
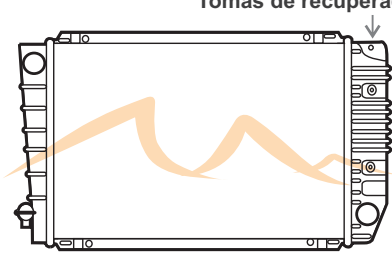

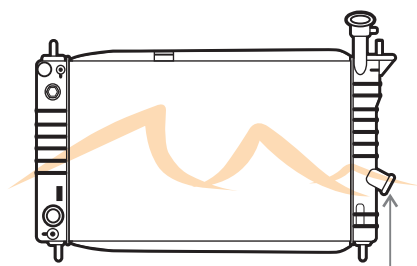
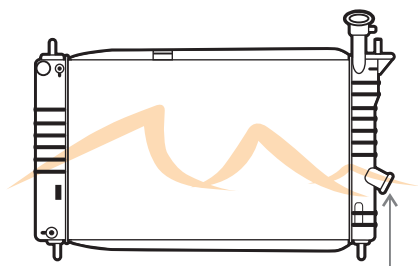
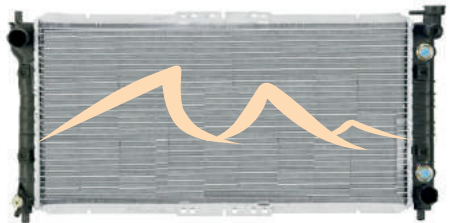
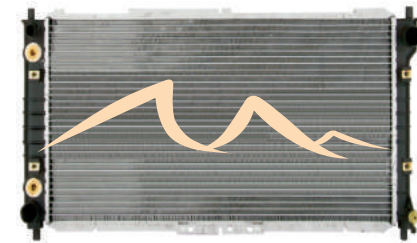
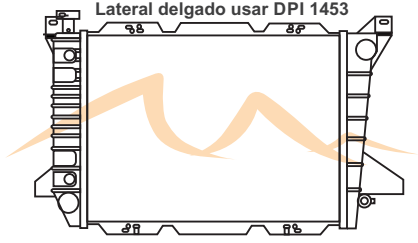
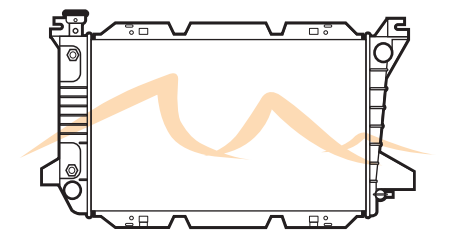
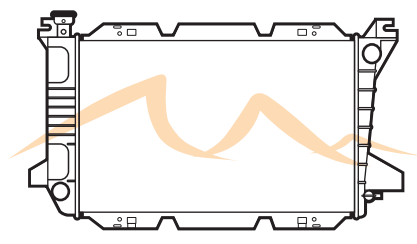
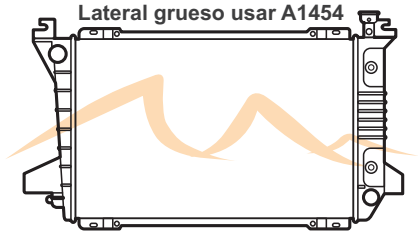
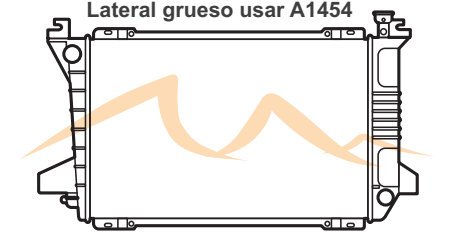
<p>A037-13N FORD</p>  <p>ECOSPORT 07-10 / FIESTA HATCHBACK 07-09 1.6 L</p> <p>PANAL: 22 1/16" X 13 9/16" X 1/2" CAB. SUP.: 14 1/8" X 1 5/8" ENTRADA: 1" CAB. INF.: 14 1/8" X 1 5/8" SALIDA: 1" ENFRIADOR: NO 05/15</p> <p>010</p>	<p>AA057-44C FORD</p>  <p>TOMS BRONCO 66-77 V8 4.7/5.0</p> <p>Todo en aluminio</p> <p>PANAL: 19" X 18 15/16" X 1 3/4" CAB. SUP.: 18 15/16" X 2 3/8" CAB. INF.: 18 15/16" X 2 3/8" ENF. TRANS.: 10"</p> <p>TOMAS: ENTRADA: 1 3/4" SALIDA: 1 1/2"</p> <p>011</p>	<p>A0227-28C FORD/MERCURY/LINCOLN</p>  <p>TOWN CAR/GRAND MARQUIS/CROWN VICTORIA 86-91 DPI 227 / 5704 PHAR V8 5.0/5.8</p> <p>PANAL: 27 5/8" X 18 3/8" X 1 1/8" CS: 3" X 18 1/2" ENTRADA: 1 1/2" CI: 1 7/8" X 18 1/2" SALIDA: 1 1/2"</p> <p>ENFRIADOR: SI</p> <p>012</p>
<p>A0891-44C FORD</p>  <p>TAURUS 86-88 / MERCURY SABLE 88-89 DPI-0891 V6 3.0</p> <p>PANAL: 24" X 14 3/8" X 1 3/4" CAB. SUP.: 3 1/6" X 15 1/8" ENTRADA: 1 1/2" CAB. INF.: 3 1/6" X 15 1/8" SALIDA: 1 1/2"</p> <p>ENFRIADOR: SI, 10" 756348-M 10/15</p> <p>013</p>	<p>A0897-28N FORD</p>  <p>BRONCO 85-90/RANGER 85-94/EXPLORER 91-94 NAVAJO 91-94/B300 PICKUP V6 2.9/3.0/4.0</p> <p>PANAL: 18" X 18" X 1 1/8" CAB. SUP.: 1 7/8" X 18 1/2" CAB. INF.: 1 7/8" X 18 1/2" ENF. TRANS.: NO ENF. MOTOR: NO</p> <p>TOMAS: ENTRADA: 1 1/2" SALIDA: 1 1/2"</p> <p>014</p>	<p>A0901-28C FORD</p>  <p>AEROSTAR 86-97 DPI 901 / 5630 PHAR V6 2.8/3.0</p> <p>PANAL: 22 1/2" X 18" X 1 1/8" CS: 3" X 18 1/2" ENTRADA: 1 1/2" CI: 1 7/8" X 18 1/2" SALIDA: 1 1/2"</p> <p>ENFRIADOR: SI</p> <p>015</p>
<p>A0901-28N FORD</p>  <p>AEROSTAR 86-97 DPI 901 / 5630 PHAR V6 2.8/3.0</p> <p>PANAL: 22 1/2" X 18 3/8" X 1 1/8" CS: 3" X 18 1/2" ENTRADA: 1 1/2" CI: 1 7/8" X 18 1/2" SALIDA: 1 1/2"</p> <p>EDA: NO ENFRIADOR: NO</p> <p>016</p>	<p>A1061-28C MAZDA/FORD</p>  <p>RANGER/BRONCO/B300/EXPLORER 1994 6226 PHAR V6 2.8/2.9/3.0/4.0</p> <p>PANAL: 18" X 19 5/8" X 1 1/8" (28 mm) CS: 3" X 18 1/2" ENTRADA: 1 1/2" CI: 1 7/8" X 18 1/2" SALIDA: 1 7/16"</p> <p>ENFRIADOR: SI 756347</p> <p>017</p>	<p>A1062-28C FORD/MAZDA</p>  <p>B2300 1994/RANGER 85-94 DPI 1062 / 5633 PHAR L4 2.0/2.3</p> <p>PANAL: 18" X 17 15/16" X 1 1/8" CS: 3" X 18 1/2" ENTRADA: 1 1/2" CI: 1 7/8" X 18 1/2" SALIDA: 1 1/2"</p> <p>ENFRIADOR: SI</p> <p>018</p>

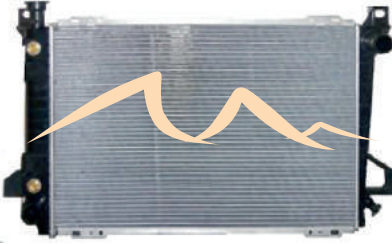
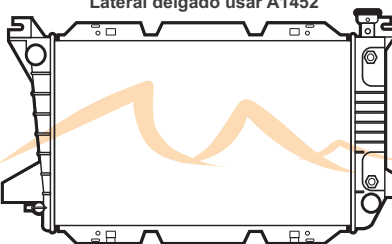
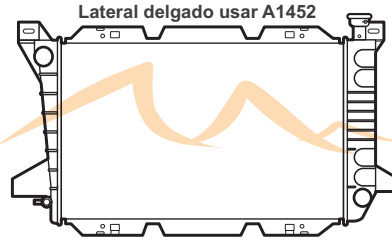
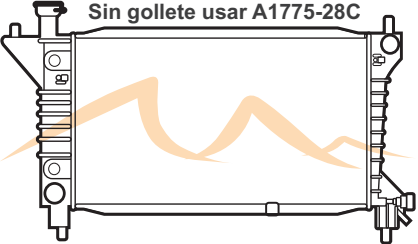
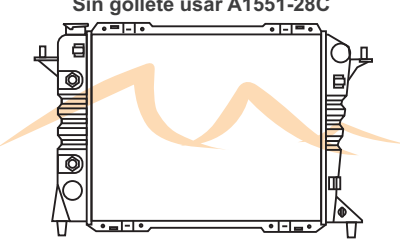
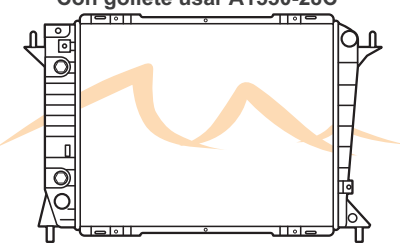
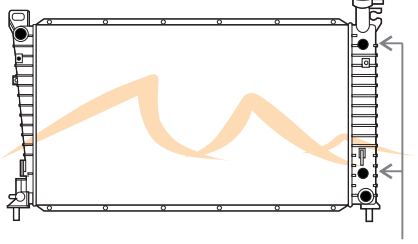
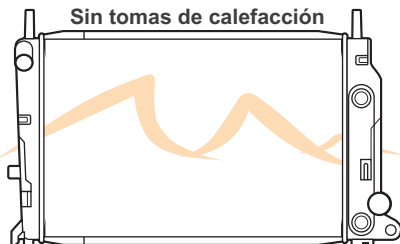
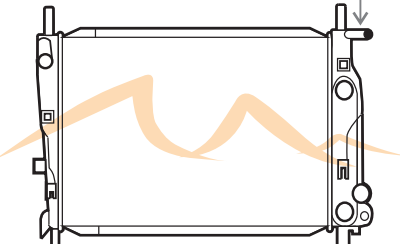
<p>A1062-28N FORD/MAZDA</p>  <p>B2300 1994/RANGER 85-99</p> <p>DPI 1062 / 5633 PHAR L4 2.0/2.3</p> <p>PANAL: 18" X 17 15/16" X 1 1/8" CS: 3" X 18 1/2" CI: 1 7/8" X 18 1/2"</p> <p>ENTRADA: 1 1/2" SALIDA: 1 1/2"</p> <p>ENFRIADOR: NO</p> <p style="text-align: right;">019</p>	<p>A1094-28C FORD/MERCURY/LINCOLN</p> <p>Montaje detrás de gollete</p>  <p>CONTINENTAL/TAURUS/SABLE 86-95</p> <p>DPI 1094 / 2905 PHAR V6 3.0/3.8</p> <p>PANAL: 24" X 15" X 1 1/8" CS: 2" X 15 1/2" CI: 3 X 15 1/2"</p> <p>ENTRADA: 1 1/2" SALIDA: 1 1/2"</p> <p>ENFRIADOR: SI</p> <p style="text-align: right;">020</p>	<p>A1095-28C FORD/MERCURY</p>  <p>THUNDERBIRD 89-92/COUGAR 89-93</p> <p>DPI-1095 V6 3.8/ V8 5.0</p> <p>PANAL: 22 3/8" X 18 X 1 1/8" CAB. SUP.: 1 7/8" X 18 7/16" CAB. INF.: 1 7/8" X 18 7/16"</p> <p>ENTRADA: 1 3/8" SALIDA: 1 1/2"</p> <p>ENFRIADOR: SI, 8" 756386-M 09/15</p> <p style="text-align: right;">021</p>
<p>A1164-44C FORD/MAZDA</p>  <p>Toma hacia afuera</p> <p>Toma curva hacia abajo</p> <p>NAVAJO/B3000/B4000 91-94/EXPLORER/RANGER 90-94</p> <p>DPI 1164 / 6029 PHAR V6 3.0/4.0</p> <p>PANAL: 18" X 18" X 1 3/4" CS: 3" X 18 1/2" CI: 3" X 18 1/2"</p> <p>ENTRADA: 1 1/2" SALIDA: 1 1/2"</p> <p>ENFRIADOR: SI</p> <p style="text-align: right;">022</p>	<p>A1273-13C FORD/MERCURY</p> <p>Base sensor</p>  <p>Toma hacia afuera</p> <p>TRACKER 91-99/ESCORT 91-02</p> <p>DPI 1273 / 5589 PHAR L4 1.8/1.9/2.0</p> <p>PANAL: 21 5/8" X 16 5/8" X 1/2" CS: 1 7/8" X 17 1/8" CI: 1 7/8" X 17 1/8"</p> <p>ENTRADA: 1 3/8" SALIDA: 1 3/8"</p> <p>ENFRIADOR: SI</p> <p style="text-align: right;">023</p>	<p>A1273-28C FORD/MERCURY</p> <p>Base sensor</p>  <p>Toma hacia afuera</p> <p>TRACKER 91-99/ESCORT 91-02</p> <p>DPI 1273 / 5589 PHAR L4 1.8/1.9/2.0</p> <p>PANAL: 21 5/8" X 16 5/8" X 1 1/8" CS: 1 7/8" X 17 1/8" CI: 1 7/8" X 17 1/8"</p> <p>ENTRADA: 1 3/8" SALIDA: 1 3/8"</p> <p>ENFRIADOR: SI</p> <p style="text-align: right;">024</p>
<p>A1274-13N FORD</p> <p>Base sensor</p>  <p>Toma hacia afuera</p> <p>TRACER 91-99/ESCORT 91-02</p> <p>DPI 1274 / 5589 PHAR L4 1.8/1.9/2.0</p> <p>PANAL: 21 5/8" X 16 5/8" X 1/2" CS: 1 7/8" X 17 1/8" CI: 1 7/8" X 17 1/8"</p> <p>ENTRADA: 1 3/8" SALIDA: 1 3/8"</p> <p>ENFRIADOR: NO</p> <p style="text-align: right;">025</p>	<p>A1274-28N FORD</p> <p>Base sensor</p>  <p>Toma hacia afuera</p> <p>TRACER 91-99/ESCORT 91-02</p> <p>DPI 1274 / 5589 PHAR L4 1.8/1.9/2.0</p> <p>PANAL: 21 5/8" X 16 5/8" X 1 1/8" CS: 1 7/8" X 17 1/8" CI: 1 7/8" X 17 1/8"</p> <p>ENTRADA: 1 3/8" SALIDA: 1 3/8"</p> <p>ENFRIADOR: NO</p> <p style="text-align: right;">026</p>	<p>A1279-28C FORD/MERCURY/LINCOLN</p> <p>Tomas de recuperador</p>  <p>TOWN CAR 91-94/CROWN VICTORIA/ GRAND MARQUIS 92-94</p> <p>DPI 1279 / 5701 PHAR V8 4.6</p> <p>PANAL: 27 1/2" X 18 3/8" X 1 1/8" CS: 1 7/8" X 18 1/2" CI: 3" X 18 7/16"</p> <p>ENTRADA: 1 1/2" SALIDA: 1 1/2"</p> <p>ENFRIADOR: SI NOTAS: SIN GOLLETE</p> <p style="text-align: right;">027</p>

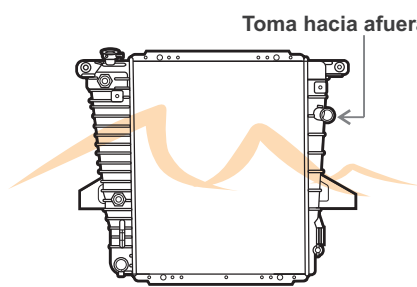
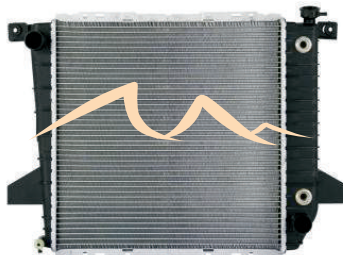
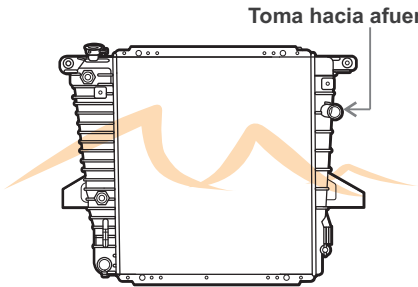
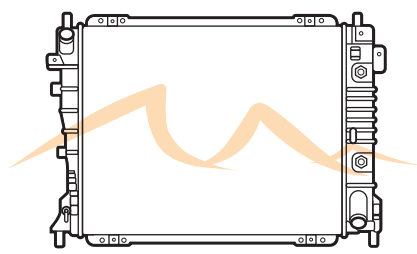
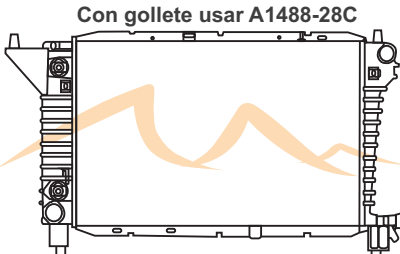
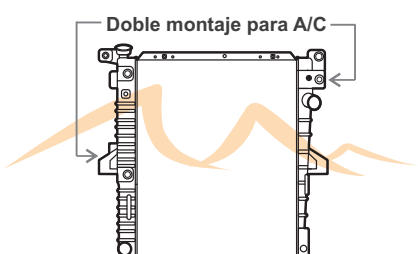
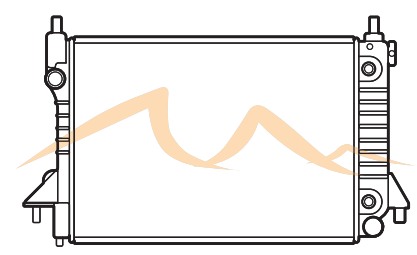
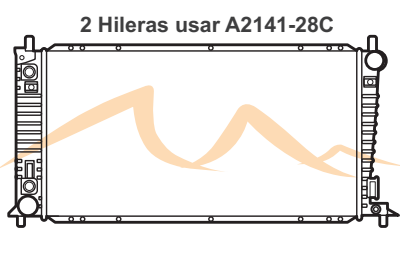
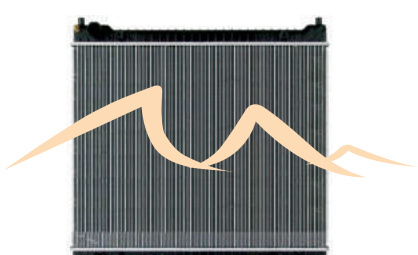
<p>A1322-28C FORD/MERCURY</p>  <p>Toma hacia afuera</p> <p>TEMPO/TOPAZ 92-94</p> <p>DPI 1322 / 5587 PHAR L4 2.3 V6 3.0</p> <p>PANAL: 24" X 14 7/8" X 1 1/8" CS: 1 3/4" X 15 1/8" CI: 3" X 15 1/8"</p> <p>ENTRADA: 1 3/8" SALIDA: 1 3/8"</p> <p>ENFRIADOR: SI</p> <p>028</p>	<p>A1322-28N FORD/MERCURY</p>  <p>Toma hacia abajo</p> <p>TEMPO/TOPAZ 92-94</p> <p>DPI 1322 / 5587 PHAR L4 2.3 V6 3.0</p> <p>PANAL: 24" X 14 7/8" X 1 1/8" CS: 1 3/4" X 15 1/8" CI: 3" X 15 1/8"</p> <p>ENTRADA: 1 3/8" SALIDA: 1 3/8"</p> <p>ENFRIADOR: NO</p> <p>029</p>	<p>A1324-28C FORD</p>  <p>PROBE 93-97</p> <p>L4 2.0</p> <p>PANAL: 27 1/8" X 12 3/8" X 1 1/8" CAB. SUP.: 13 11/16" X 1 15/16" CAB. INF.: 13 11/16" X 1 15/16"</p> <p>TOMAS: ENTRADA: 1 3/8" SALIDA: 1 3/8"</p> <p>ENF. TRANS.: SI ENF. MOTOR: NO</p> <p>030</p>
<p>A1325-28C FORD</p>  <p>PROBE GT 93-97</p> <p>V6 2.5L</p> <p>PANAL: 27 1/8" X 13 3/16" X 1 1/8" CAB. SUP.: 1 15/16" X 13 5/8" CAB. INF.: 1 15/16" X 13 5/8"</p> <p>TOMAS: ENTRADA: 1 3/8" SALIDA: 1 3/8"</p> <p>ENFRIADOR: SI</p> <p>031</p>	<p>A1451-28C FORD</p>  <p>Lateral delgado usar DPI 1453</p> <p>F150/250/350/BRONCO 85-97</p> <p>DPI 1451 / 3382 PHAR V8 5.0/5.8/7.5</p> <p>PANAL: 27 1/2" X 18 1/9" X 1 1/8" CS: 3 1/16" X 18 1/2" CI: N/A</p> <p>ENTRADA: 1 3/4" SALIDA: 1 3/4"</p> <p>ENFRIADOR: SI, 756347</p> <p>032</p>	<p>A1451-44C FORD</p>  <p>BRONCO 85-97/SERIES PICK UP 85-97</p> <p>DPI 1451 / 3382 PHAR V8 5.0/5.8/7.5</p> <p>PANAL: 27 5/8" X 18 3/8" X 1 3/4" CS: 3" X 18 1/2" CI: 3" X 18 1/2"</p> <p>ENTRADA: 1 3/4" SALIDA: 1 3/4"</p> <p>ENFRIADOR: SI 756347</p> <p>033</p>
<p>A1451-44N FORD</p>  <p>BRONCO 85-97/SERIES PICK UP 85-97</p> <p>DPI 1451 / 3382 PHAR V8 5.0/5.8/7.5</p> <p>PANAL: 27 5/8" X 18 3/8" X 1 3/4" CS: 3" X 18 1/2" CI: 3 X 18 1/2"</p> <p>ENTRADA: 1 3/4" SALIDA: 1 3/4"</p> <p>ENFRIADOR: NO</p> <p>034</p>	<p>A1452-28C FORD</p>  <p>Lateral grueso usar A1454</p> <p>BRONCO/F-SERIES/PICK UP 85-96</p> <p>DPI 1452 / 3381 PHAR L6 4.9</p> <p>PANAL: 27 5/8" X 18 3/8" X 1 1/8" CS: 1 7/8" X 18 1/2" CI: 3" X 18 1/2"</p> <p>ENTRADA: 1 3/4" SALIDA: 1 3/4"</p> <p>ENFRIADOR: SI 756347</p> <p>035</p>	<p>A1452-28N FORD</p>  <p>Lateral grueso usar A1454</p> <p>BRONCO/F-SERIES/PICK UP 85-96</p> <p>DPI 1452 / 3381 PHAR L6 4.9</p> <p>PANAL: 27 5/8" X 18 3/8" X 1 1/8" CS: 1 7/8" X 18 1/2" CI: 3" X 18 1/2"</p> <p>ENTRADA: 1 3/4" SALIDA: 1 3/4"</p> <p>ENFRIADOR: NO</p> <p>036</p>

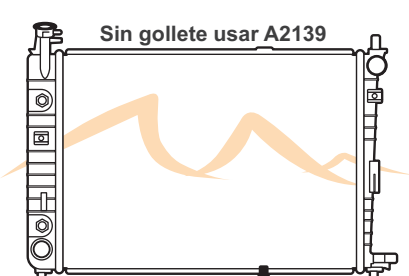
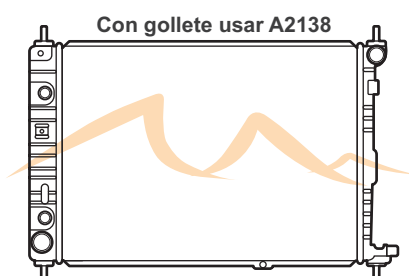

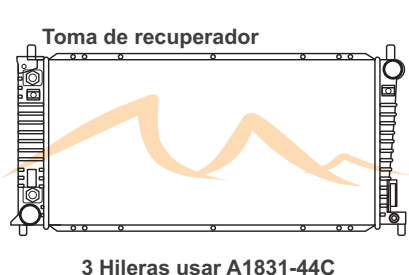
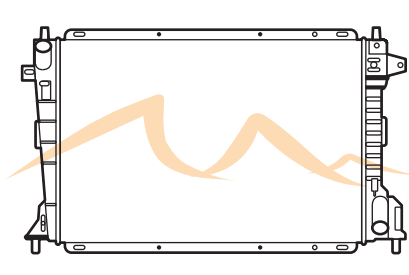
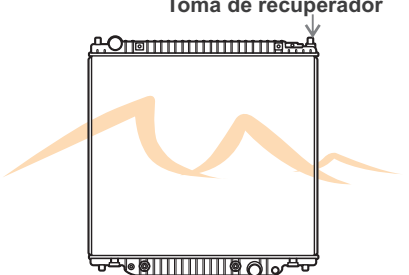
<p>A1453-28C FORD</p>  <p>BRONCO 85-97/PICK UP SERIES 85-97 PHAR 3384 V8 5.0/5.8</p> <p>PANAL: 27 1/2" X 18" X 1 1/8" CAB. SUP.: 1 7/8" X 18 1/2" CAB. INF.: 3" X 18 1/2" ENF. TRANS.: SI ENF. MOTOR: NO</p> <p>TOMAS: ENTRADA: 1 3/4" SALIDA: 1 3/4"</p> <p>037</p>	<p>A1454-44C FORD</p>  <p>BRONCO/F-SERIES/PICK UP 85-96 DPI 1454 / 3383 PHAR L6 4.9</p> <p>PANAL: 27 5/8" X 18 3/8" X 1 3/4" CS: 3" X 18 1/2" CI: 3" X 18 1/2"</p> <p>ENTRADA: 1 3/4" SALIDA: 1 3/4"</p> <p>ENFRIADOR: SI</p> <p>038</p>	<p>A1454-44N FORD</p>  <p>BRONCO/F-SERIES PICK UP 85-96 DPI 1454 / 3383 PHAR L6 4.9</p> <p>PANAL: 27 5/8" X 18 3/8" X 1 3/4" CS: 3" X 18 1/2" CI: 3" X 18 1/2"</p> <p>ENTRADA: 1 3/4" SALIDA: 1 3/4"</p> <p>ENFRIADOR: NO</p> <p>039</p>
<p>A1488-28C FORD</p>  <p>MUSTANG 94-96 DPI 1488 / 3388 PHAR V6 3.8 V8 5.0</p> <p>PANAL: 24" X 14 7/8" X 1 1/8" CS: 3 1/8" X 15 1/8" CI: 3 1/8" X 15 1/8"</p> <p>ENTRADA: 1 3/8" SALIDA: 1 3/4"</p> <p>ENFRIADOR: SI</p> <p>040</p>	<p>A1550-28C FORD</p>  <p>COUGAR/THUNDERBIRD 94-97 DPI 1550 / 6110 PHAR V6 3.8</p> <p>PANAL: 22 7/16" X 20 1/16" X 1 1/8" CS: 1 7/8" X 18 1/2" CI: 3 1/16" X 18 1/2"</p> <p>ENTRADA: 1 1/2" SALIDA: 1 1/2"</p> <p>ENFRIADOR: SI</p> <p>041</p>	<p>A1551-28C FORD/MERCURY/LINCOLN</p>  <p>MARK VIII/THUNDERBIRD/COUGAR 94-97 DPI 1551 / 5631 PHAR V8 4.6</p> <p>PANAL: 22" X 18 3/8" X 1 1/8" (28 mm) CS: 3" X 18 1/2" CI: 1 7/8" X 18 1/2"</p> <p>ENTRADA: 1 1/2" SALIDA: 1 1/2"</p> <p>ENFRIADOR: SI 756348</p> <p>042</p>
<p>A1609-28P6 FORD</p>  <p>WINDSTAR 95-98 DPI 1609 / 3386 PHAR V6 3.0/3.8</p> <p>PANAL: 30" X 17" X 1 1/8" CS: 2" X 17 3/8" CI: 3" X 17 3/8"</p> <p>ENTRADA: 1 1/2" SALIDA: 1 1/2"</p> <p>EDA: SI EDAM: NO</p> <p>043</p>	<p>A1718-28C FORD/MERCURY</p>  <p>CONTOUR/MYSTIQUE 95-00 6103 PHAR L4 2.0 V6 2.5</p> <p>PANAL: 24 3/8" X 15 5/8" X 1" (26 mm) CS: 2" X 16" CI: 3" X 16"</p> <p>ENTRADA: 1 3/8" SALIDA: 1 3/8"</p> <p>EDA: 10" 7 PLACAS EDAM: NO</p> <p>044</p>	<p>A1719-28C FORD/MERCURY</p>  <p>COUGAR/CONTOUR/MYSTIQUE 95-00 3389 PHAR L4 2.0 V6 2.5</p> <p>PANAL: 24 3/8" X 15 5/8" X 1 1/8" CS: 2" X 16" CI: 3" X 16"</p> <p>ENTRADA: 1 3/8" SALIDA: 1 3/8"</p> <p>ENFRIADOR: SI</p> <p>045</p>

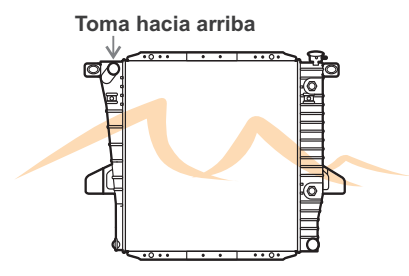
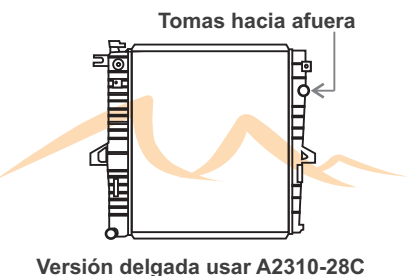
<p>A1722-28C FORD/MAZDA</p>  <p>RANGER/B4000/B3000/ PICK UP 95-97 DPI 1722 / 6005 PHAR V6 3.0/4.0</p> <p>PANAL: 17 1/4" X 21 1/2" X 1 1/8" CS: 1 7/8" X 21 1/2" CI: 3" X 21 1/2"</p> <p>ENTRADA: 1 1/2" SALIDA: 1 1/2"</p> <p>ENFRIADOR: SI</p> <p style="text-align: right;">046</p>	<p>A1726-28C FORD/MAZDA</p>  <p>RANGER 95-97/F100 96-97/MAZDA B2300 95-97 5639 PHAR / DPI 1726 L4 2.3</p> <p>PANAL: 18" X 17 7/8" X 1 1/8" CAB. SUP.: 18 7/16" X 1 3/4" CAB. INF.: 18 7/16" X 3 1/16"</p> <p>ENFRIADOR: SI</p> <p>NOTAS: Con montaje de aletas</p> <p style="text-align: right;">047</p>	<p>A1728-44C FORD</p>  <p>EXPLORER 95-97 DPI 1728 / 7002 PHAR V6 4.0</p> <p>PANAL: 20" X 21 1/2" X 1 3/4" CS: 3" X 21 1/2" CI: 3" X 21 1/2"</p> <p>ENTRADA: 1 1/2" SALIDA: 1 1/2"</p> <p>ENFRIADOR: SI</p> <p style="text-align: right;">048</p>
<p>A1737-28C FORD/MERCURY/LINCOLN</p>  <p>TOWN CAR 95-97/CROWN VICTORIA/GRAND MARQUIS 95-97 5707 PHAR V8 4.6</p> <p>PANAL: 27 5/8" X 18 3/8" X 1 1/8" CS: 1 7/8" X 18 1/2" CI: 3" X 18 1/2"</p> <p>ENTRADA: 1 1/2" SALIDA: 1 1/2"</p> <p>ENFRIADOR: SI</p> <p style="text-align: right;">049</p>	<p>A1775-28C FORD</p>  <p>MUSTANG 96 DPI 1775 / 6034 PHAR V8 4.6</p> <p>PANAL: 24" X 14 3/8" X 1 1/8" CS: 1 13/16" X 15 1/16" CI: 3 1/16" X 15 1/8"</p> <p>ENTRADA: 1 1/2" SALIDA: 1 3/4"</p> <p>ENFRIADOR: SI</p> <p style="text-align: right;">050</p>	<p>A1824-44C FORD/MERCURY</p>  <p>EXPLORER/MOUNTAINEER 96-99 DPI 1824 / 6114 PHAR V8 5.0</p> <p>PANAL: 20 1/2" X 23 5/8" X 1 3/4" CS: 3" X 23 3/4" CI: 3" X 23 3/4"</p> <p>ENTRADA: 1 1/2" SALIDA: 1 1/2"</p> <p>ENFRIADOR: SI</p> <p style="text-align: right;">051</p>
<p>A1830-28P7 FORD/MERCURY</p>  <p>TAURUS/SABLE 96-05 DPI 1830 / 6032 PHAR V6 3.0/3.4</p> <p>PANAL: 28 3/8" X 14 7/8" X 1 1/8" CS: 1 7/8" X 15 1/8" CI: 3" X 15 1/8"</p> <p>ENTRADA: 1 1/2" SALIDA: 1 1/2"</p> <p>ENFRIADOR: SI 3 PLACAS</p> <p style="text-align: right;">052</p>	<p>A1831-44C FORD/LINCOLN</p>  <p>EXPEDITION/NAVIGATOR 99-02/F-SERIES PICK UP 97-98 DPI 2136 / 7012 PHAR V8 4.6/5.4</p> <p>PANAL: 31 7/8" X 17" X 1 3/4" CS: 3" X 17" CI: 3" X 17"</p> <p>ENTRADA: 1 3/4" SALIDA: 1 3/4"</p> <p>ENFRIADOR: SI</p> <p style="text-align: right;">053</p>	<p>A1995-44C FORD</p>  <p>E-150/E-250/E-350/E-450 SUPER DUTY/ECOLINE 97-13 DPI 1995 / 6026, 6132, 6133 PHARV8 5.4/7.3 V10 6.8</p> <p>PANAL: 23 5/8" X 29 1/2" X 1 3/4" CAB. SUP.: 3" X 30 3/8" CAB. INF.: 3" X 30 3/8"</p> <p>ENF. TRANS.: SI ENF. MOTOR: NO</p> <p>TOMAS: ENTRADA: 1 3/4" SALIDA: 1 3/4"</p> <p style="text-align: right;">054</p>

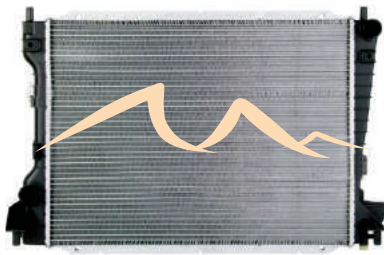
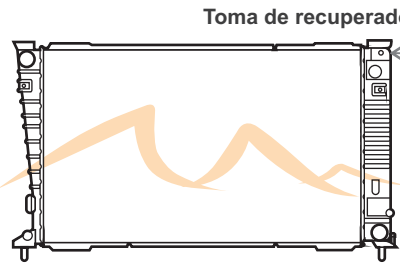
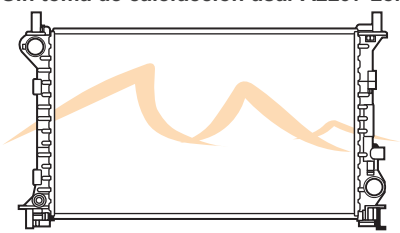
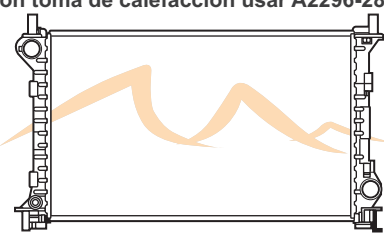
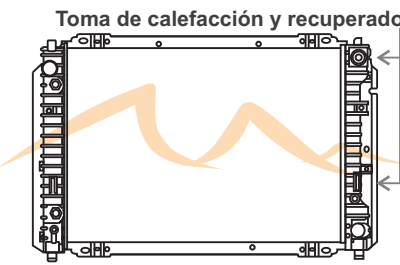
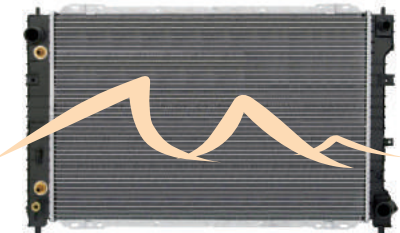
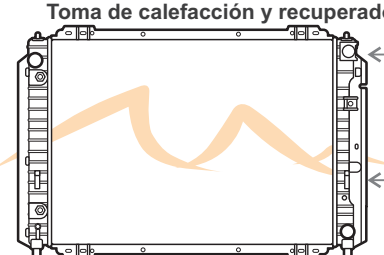
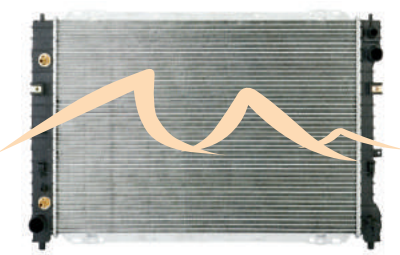
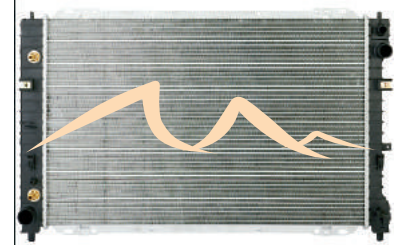

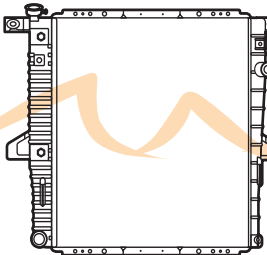
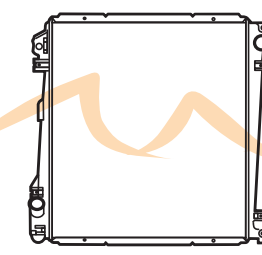
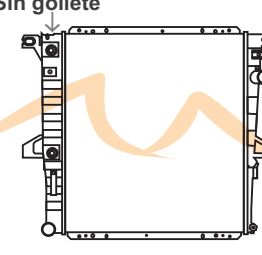
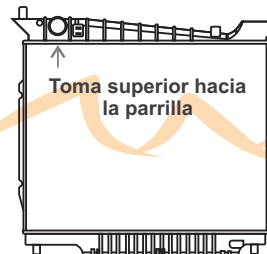
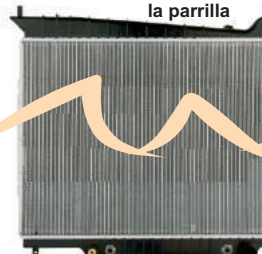
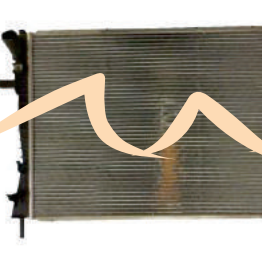
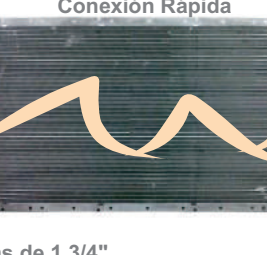
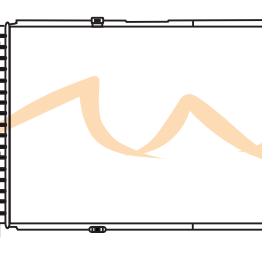
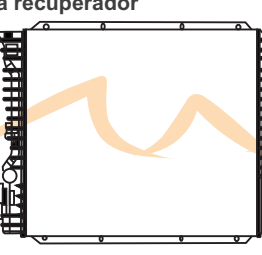
<p>A2138-28C FORD</p>  <p>Sin gollete usar A2139</p> <p>MUSTANG 97-04</p> <p>DPI 2138 / 6236 PHAR V6 3.8</p> <p>PANAL: 25" X 17 1/8" X 1 1/8" CS: 3" X 17 3/16" CI: 1 7/8" X 17 3/16"</p> <p>ENTRADA: 1 1/2" SALIDA: 1 3/4"</p> <p>ENFRIADOR: SI</p> <p>055</p>	<p>A2139-28C FORD</p>  <p>Con gollete usar A2138</p> <p>MUSTANG 97-04</p> <p>3387 PHAR V8 4.6</p> <p>PANAL: 25" X 17 1/8" X 1 1/8" (28 mm) CS: 3" X 17 3/16" CI: 1 7/8" X 17 3/16"</p> <p>ENTRADA: 1 1/2" SALIDA: 1 3/4"</p> <p>ENFRIADOR: SI</p> <p>056</p>	<p>A2140-28C FORD</p>  <p>Sin toma de calefacción usar A1273-28C</p> <p>Con toma de calefacción</p> <p>ESCORT ZX2 97-03</p> <p>DPI 2140 / 6038 PHAR L4 2.0</p> <p>PANAL: 21 5/8" X 16 5/8" X 1 1/8" CS: 1 7/8" X 17 1/8" CI: 1 7/8" X 17 1/8"</p> <p>ENTRADA: 1 3/8" SALIDA: 1 3/8"</p> <p>EDA: SI EDAM:</p> <p>057</p>
<p>A2141-28C FORD</p>  <p>Toma de recuperador</p> <p>3 Hileras usar A1831-44C</p> <p>F-SERIES/EXPEDITION 97-98</p> <p>DPI 2141 / 3385 PHAR V8 4.2/4.6</p> <p>PANAL: 32" X 17" X 1 1/8" CS: 3" X 17 1/2" CI: 2" X 17 1/2"</p> <p>ENTRADA: 1 3/4" SALIDA: 1 3/4"</p> <p>ENFRIADOR: SI</p> <p>058</p>	<p>A2157-28N FORD/MERCURY/LINCOLN</p>  <p>TOWN CAR/CROWN VICTORIA/GRAND MARQUIS 98-05</p> <p>7007 PHAR V8 4.6</p> <p>PANAL: 27 1/2" X 18 3/8" X 1 1/8" CS: 1 7/8" X 18 1/2" CI: 1 7/8" X 18 1/2"</p> <p>ENTRADA: 1 1/2" SALIDA: 1 1/2"</p> <p>ENFRIADOR: NO</p> <p>059</p>	<p>A2170-28C FORD</p>  <p>Toma de recuperador</p> <p>EXCURSION00-05/F-SERIES/ENCONLINE/VAN 97-06</p> <p>DPI 2170 / 5658 PHAR V8 5.4</p> <p>PANAL: 26 1/2" X 29 11/16" X 1 1/8" CS: 3 1/16" X 30 3/8" CI: 3 1/16" X 30 3/8"</p> <p>ENTRADA: 1 3/4" SALIDA: 1 3/4"</p> <p>ENFRIADOR: SI</p> <p>060</p>
<p>A2171-60C FORD</p>  <p>Toma de recuperador y calefacción lado copiloto</p> <p>Sin Gollete</p> <p>EXCURSION/SUPER DUTY/S-SERIES 98-05</p> <p>V8 7.3 V10 6.3</p> <p>PANAL: 26 1/2" X 29 13/16" X 2 3/8" CS: 3 1/16" X 30 3/8" CI: 3 1/16" X 30 3/8"</p> <p>ENTRADA: 1 3/4" SALIDA: 1 3/4"</p> <p>EDA: SI EDAM: NO</p> <p>061</p>	<p>A2172-28C FORD/MAZDA</p>  <p>Toma hacia arriba</p> <p>RANGER/B2500 98-01</p> <p>DPI 2172 / 5638 PHAR L4 2.5</p> <p>PANAL: 20" X 21 1/2" X 1 1/8" CS: 1 7/8 X 21 1/2" CI: 3 X 21 1/2"</p> <p>ENTRADA: 1 1/2" SALIDA: 1 1/2"</p> <p>ENFRIADOR: SI</p> <p>062</p>	<p>A2174-44C FORD/MERCURY</p>  <p>Tomas hacia afuera</p> <p>Versión delgada usar A2310-28C</p> <p>MOUNTAINER 98-99 / EXPLORER 97-99</p> <p>DPI 2174 / 6017 PHAR V6 4.0</p> <p>PANAL: 20 5/8" X 23 3/8" X 1 3/4" CS: 3 1/16" X 23 3/4" CI: 3" X 23 3/4"</p> <p>ENTRADA: 1 1/2" SALIDA: 1 1/2"</p> <p>ENFRIADOR: SI</p> <p>063</p>

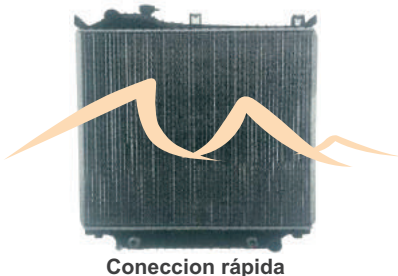
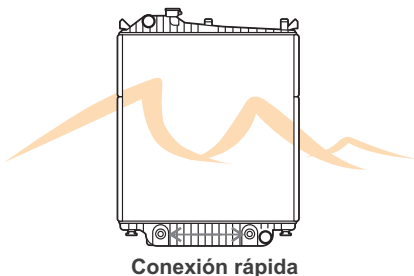

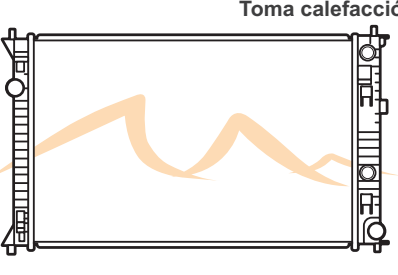
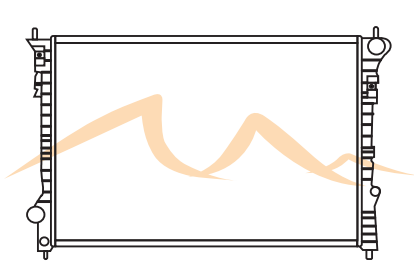
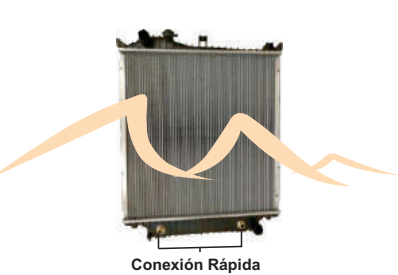
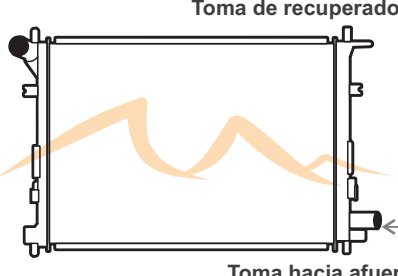
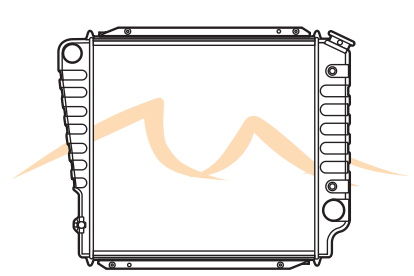
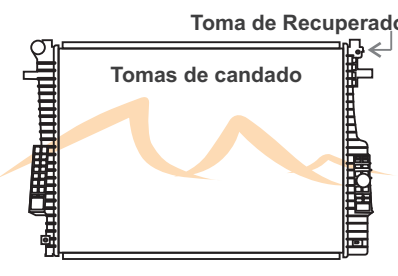

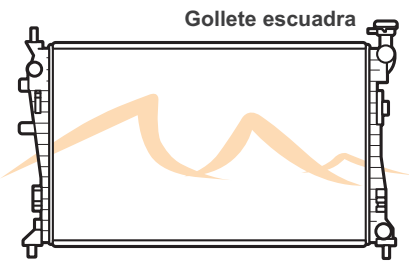
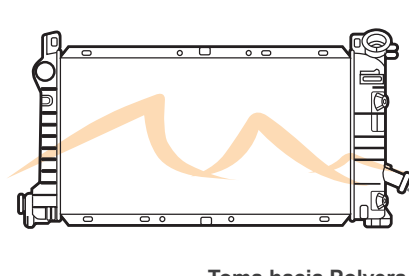
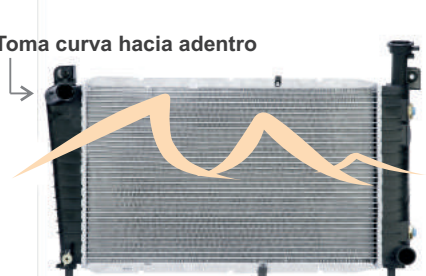
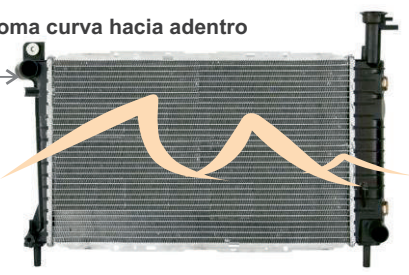
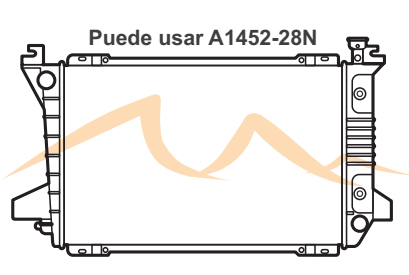
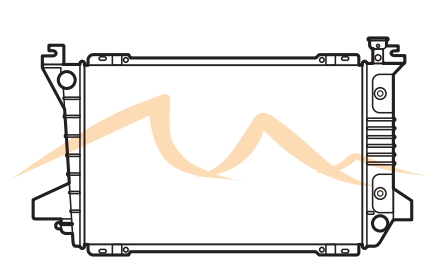
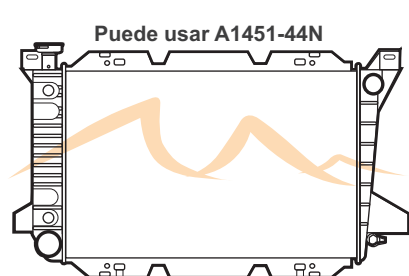
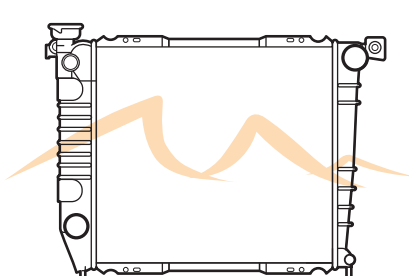
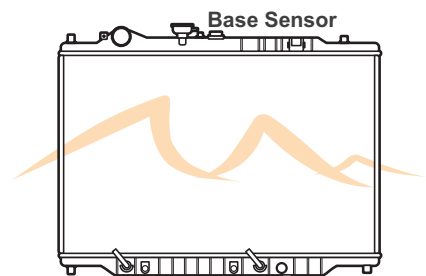
<p>A2256-28N FORD/LINCOLN/JAGUAR</p>  <p>THUNDERBIRD 02-05/LS 00-06/S-TYPE SUPER 00-09 V6 3.0 V8 3.9/4.0/4.2</p> <p>PANAL: 24 1/8" X 18 3/8" X 1 1/8" CS: 1 7/8" X 18 7/16" CI: 1 7/8" X 18 7/16" EDA: NO EDAM: NO</p> <p>ENTRADA: 1 1/2" SALIDA: 1 1/2"</p> <p>064</p>	<p>A2258-28P7 FORD</p>  <p>Toma de recuperador</p> <p>FREESTAR 04-07/WINDSTAR 99-04 DPI 2258 / 6011 PHAR V6 3.0/3.8/3.9/4.2</p> <p>PANAL: 30" X 17" X 1 1/8" CS: 1 7/8" X 17 3/16" CI: 3 1/16" X 17 3/16" EDA: 12" EDAM: NO</p> <p>ENTRADA: 1 1/2" SALIDA: 1 1/2"</p> <p>065</p>	<p>A2296-28N FORD</p>  <p>Sin toma de calefacción usar A2297-28N</p> <p>FOCUS ZX3 00-07 DPI 2296 / 7001 PHAR L4 2.0/2.3</p> <p>PANAL: 23 1/2" X 15" X 1 1/8" CS: 1 15/16" X 14 7/16" CI: 1 15/16" X 14 7/16"</p> <p>ENTRADA: 1 1/4" SALIDA: 1 1/4"</p> <p>ENFRIADOR: NO</p> <p>066</p>
<p>A2297-28N FORD</p>  <p>Con toma de calefacción usar A2296-28N</p> <p>FOCUS 00-06 DPI 2297 L4 2.0</p> <p>PANAL: 23 5/8" X 14" X 1 1/8" CS: 1 15/16" X 14 7/16" CI: 1 15/16" X 14 7/16" MAQ. 2.0 LTS. L4 98 A/T ENFRIADOR: NO NOTAS: SIN TUBO DE CALEFACCION</p> <p>ENTRADA: 1 1/4" SALIDA: 1 1/4"</p> <p>067</p>	<p>A2306-13C FORD/MERCURY/MAZDA</p>  <p>Toma de calefacción y recuperador</p> <p>ESCAPE/TRIBUTE 01-04 DPI 2306 L4 2.0</p> <p>PANAL: 27 1/2" X 18 3/8" X 1 1/8" CS: 1 7/8" X 18 1/2" CI: 1 7/8" X 18 1/2"</p> <p>ENTRADA: 1 1/4" SALIDA: 1 1/4"</p> <p>ENFRIADOR: SI</p> <p>068</p>	<p>A2306-26C FORD/MAZDA</p>  <p>Tomas de calefacción y recuperador</p> <p>ESCAPE 01-04/ TRIBUTE DX 01-04 DPI 2306 L4 2.0</p> <p>PANAL: 27 9/16" X 17 3/4" X 1" CAB. SUP.: 18 1/2" X 1 13/16" CAB. INF.: 18 1/2" X 1 13/16" ENFRIADOR: SI 12"</p> <p>TOMAS: ENTRADA: 1 3/8" SALIDA: 1 3/8"</p> <p>069</p>
<p>A2306-28C FORD/MERCURY/MAZDA</p>  <p>Toma de calefacción y recuperador</p> <p>ESCAPE/TRIBUTE 01-04 DPI 2306 L4 2.0/2.3</p> <p>PANAL: 27 1/2" X 18 3/8" X 1 1/8" CS: 1 7/8" X 18 1/2" CI: 1 7/8" X 18 1/2"</p> <p>ENTRADA: 1 1/4" SALIDA: 1 1/4"</p> <p>ENFRIADOR: SI</p> <p>070</p>	<p>A2307-26C FORD/MAZDA</p>  <p>Toma de calefacción Toma entrada de motor</p> <p>ESCAPE 01-08 / TRIBUTE DX 01-06 DPI 2307 V6 3.0</p> <p>PANAL: 27 9/16" X 17 3/4" X 1" CAB. SUP.: 18 1/2" X 1 13/16" CAB. INF.: 18 1/2" X 1 13/16" ENFRIADOR: SI 12"</p> <p>TOMAS: ENTRADA: 1 1/4" SALIDA: 1 1/2"</p> <p>071</p>	<p>A2307-28C FORD</p>  <p>MARINER 05-08/TRIBUTE 01-06/ESCAPE 01-08 DPI 2307 V6 3.0</p> <p>PANAL: 27 1/2" X 18 3/8" X 1 1/8" CS: 1 13/16" X 18 1/2" CI: 1 13/16" X 18 1/2"</p> <p>ENTRADA: 1 1/4" SALIDA: 1 1/2"</p> <p>ENFRIADOR: SI</p> <p>072</p>

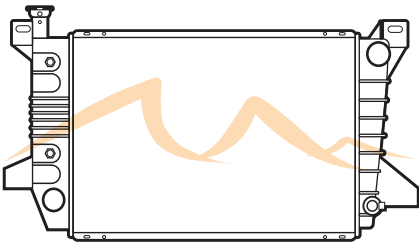
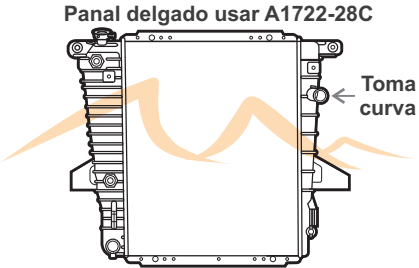
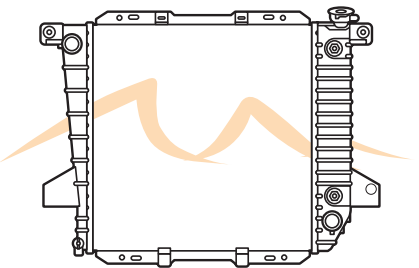
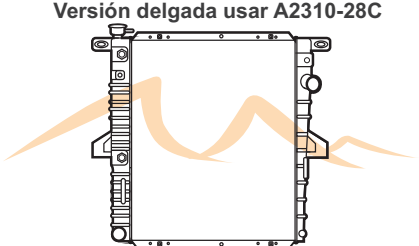
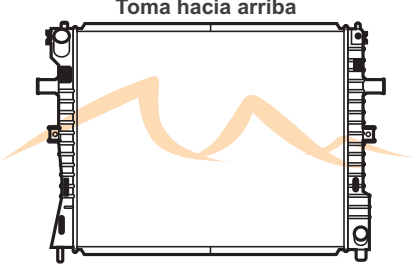
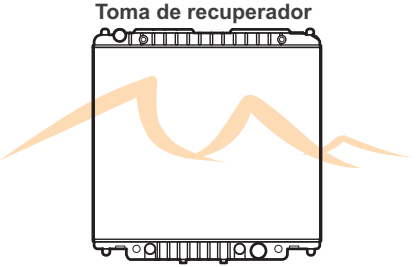
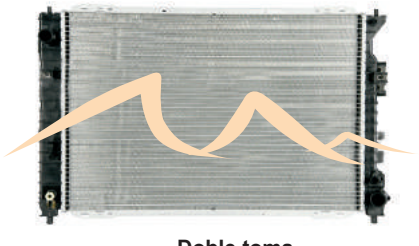
<p>A2310-28C FORD</p>  <p>EXPLORER/RANGER 98-05/09 6017 PHAR V6 3.0/4.0</p> <p>PANAL: 20 1/8" X 23 3/4" X 1 1/8" CS: 3" X 23 3/4" CI: 3" X 23 3/4"</p> <p>ENTRADA: 1 1/2" SALIDA: 1 1/2"</p> <p>ENFRIADOR: SI</p> <p style="text-align: right;">073</p>	<p>A2342-28N FORD</p>  <p>EXPLORER/MOUNTAINEER 02-05 DPI 2342 / 7014 PHAR V6 4.0 V8 4.6</p> <p>PANAL: 21 1/4" X 23 13/16" X 1 1/8" CS: 2 3/8" X 24 1/8" CI: 2 3/8" X 24 1/8"</p> <p>ENTRADA: 1 1/2" SALIDA: 1 1/2"</p> <p>ENFRIADOR: NO</p> <p style="text-align: right;">074</p>	<p>A2470-28C FORD / MAZDA</p>  <p>B2300 01-10 / RANGER 01-12 DPI 2470 L4 2.3</p> <p>PANAL: 20 3/4" X 23 1/4" X 1 1/8" CS: 3 1/16" X 23 3/4" CI: 3" X 23 3/4"</p> <p>ENTRADA: 1 1/2" SALIDA: 1 1/2"</p> <p>ENFRIADOR: SI</p> <p style="text-align: right;">075</p>
<p>A2609-44C FORD/LINCOLN</p>  <p>EXPEDITION/NAVIGATOR 03-04 DPI 2609 V8 4.6/5.4</p> <p>PANAL: 19 8/9" X 27 5/8" X 1 3/4" CS: 3" X 27 3/8" CI: 3" X 27 3/8"</p> <p>ENTRADA: 1 3/8" SALIDA: 1 3/8"</p> <p>ENFRIADOR: SI</p> <p style="text-align: right;">076</p>	<p>A2609-44P7 FORD/LINCOLN</p>  <p>EXPEDITION/NAVIGATOR 03-04 DPI 2609 V8 4.6/5.4</p> <p>PANAL: 19 7/8" X 27 3/16" X 1 3/4" CS: 3" X 27 3/8" CI: 3" X 27 3/8"</p> <p>ENTRADA: 1 3/4" SALIDA: 1 3/4"</p> <p>ENFRIADOR: SI</p> <p style="text-align: right;">077</p>	<p>A2610-28N FORD/MERCURY/LINCOLN</p>  <p>GRAND MARQUIS 03-05/CROWN VICTORIA 03-05/TOWN CAR DPI 2610 V8 4.6</p> <p>PANAL: 25 1/4" X 19 1/16" X 1 1/8" CAB. SUP.: 1 15/16" X 19 15/16" ENTRADA: 1 1/2" CAB. INF.: 1 15/16" X 19 11/16" SALIDA: 1 1/2"</p> <p>ENFRIADOR: NO</p> <p style="text-align: right;">078</p>
<p>A2719-44P7 FORD/LINCOLN</p>  <p>LOBO/F150/F250/F350 03-04/NAVIGATOR/BLACKWOOD 03,05,06 V8 4.6/5.4</p> <p>PANAL: 31 13/16" X 16 13/32" X 1 3/4" CAB. SUP.: 17 1/8" X 3" T. ENTRADA: 1 3/4" CAB. INF.: 17 1/8" X 3" T. SALIDA: 1 3/4"</p> <p>ENFRIADOR: SI 12" 7 PLACAS</p> <p>CONDENSADOR: AC3092</p> <p style="text-align: right;">079</p>	<p>A2761-28N FORD/MERCURY</p>  <p>FREESTYLE/FIVE HUNDRED/MONTEGO 05-07 2761 DPI V6 3.0</p> <p>PANAL: 25 1/16" X 17 3/4" X 1 1/8" CS: 1 7/8" X 17 3/16" CI: 1 7/8" X 17 3/16"</p> <p>ENTRADA: 1 3/8" SALIDA: 1 3/8"</p> <p>ENFRIADOR: NO</p> <p style="text-align: right;">080</p>	<p>A2789-28N FORD</p>  <p>MUSTANG 05-14 2789 DPI V6 3.7/4.0 V8 4.6/5.0</p> <p>PANAL: 24 3/16" X 19 3/16" X 1 1/8" CS: 1 13/16" X 19 13/16" ENTRADA: 1 1/2" CI: 1 13/16" X 19 13/16" SALIDA: 1 1/2"</p> <p>ENFRIADOR: NO</p> <p>CONDENSADOR: AC3362</p> <p style="text-align: right;">081</p>

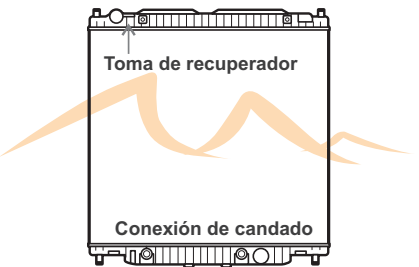
<p>A2816-28C FORD</p>  <p>Coneccion rápida</p> <p>EXPLORER/MOUNTAINEER 06-08 V6 4.0 / V8 4.6</p> <p>PANAL: 23 15/16" X 22 5/16" X 1 1/8" CAB. SUP.: 23 9/16" X 3" CAB INF.: 23 9/16" X 3" ENF. TRANS.: 12"</p> <p>TOMAS: ENTRADA: 1 1/2" SALIDA: 1 1/2"</p> <p>082</p>	<p>A2816-44C FORD/MERCURY</p>  <p>Conección rápida</p> <p>EXPLORER/MOUNTAINEER 06-07/06 V6 4.0 V8 4.6</p> <p>DPI 2816</p> <p>PANAL: 23 15/16" X 23 3/8" X 1 3/4" (44 mm) CS: 3 1/8" X 24 3/16" CI: 3 1/8" X 24 3/16"</p> <p>ENFRIDIADOR: SI</p> <p>ENTRADA: 1 3/4" SALIDA: 1 1/2"</p> <p>083</p>	<p>A2818-28P7 FORD/LINCOLN</p>  <p>Delgado</p> <p>Conexión de candado</p> <p>EXPEDITION/F-SERIES PICK UP/MARK LT 05-08 V6 4.2 V8 4.6/5.4</p> <p>PANAL: 31 7/8" X 16 7/8" X 1" (26mm) CS: 3 1/8" X 17 7/8" CI: 2" X 17 7/8" EDA: 12" 7 PLACAS EDAM: NO</p> <p>ENTRADA: 1 1/4" SALIDA: 1 1/4"</p> <p>084</p>
<p>A2856-28C FORD/MERCURY/LINCOLN</p>  <p>Toma calefacción</p> <p>FUSION 06-09/ MILAN 06-09/ ZEPHYR 06 L4 2.3 V6 3.0</p> <p>DPI 2856</p> <p>PANAL: 25 5/8" X 16 3/4" X 1 1/8" CS: 2 3/16" X 18" CI: 2 3/16" X 18" EDA: SI</p> <p>ENTRADA: 1 1/2" SALIDA: 1 1/2"</p> <p>085</p>	<p>A2936-28N FORD/LINCOLN</p>  <p>EDGE/LINCOLN MK 07-10 V6 3.5/3.7</p> <p>DPI 2936</p> <p>PANAL: 28 3/4" X 18" X 1 1/8" CS: 1 13/16" X 18 5/16" CI: 1 13/16" X 18 5/16"</p> <p>ENFRIDIADOR: NO</p> <p>ENTRADA: 1 1/2" SALIDA: 1 1/2"</p> <p>086</p>	<p>A2952-44P7 FORD/MERCURY</p>  <p>Conexión Rápida</p> <p>EXPLORER/MOUNTAINEER 07-10 V6 4.0/V8 4.6</p> <p>PANAL: 22 7/16" X 23 7/8" X 1 3/4" CS: 3 1/8" X 23 7/8" CI: 3 3/8" X 23 7/8"</p> <p>ENTRADA: 1 1/2" SALIDA: 1 1/2"</p> <p>ENFRIDIADOR: SI</p> <p>087</p>
<p>A7037-28N FORD</p>  <p>Toma de recuperador</p> <p>Toma hacia afuera</p> <p>M/T FIESTA 00-07 L4 1.6/1.8</p> <p>7037 PHAR</p> <p>PANAL: 19 7/8" X 15 17/32" X 1 1/8" CS: 1 7/8" X 16" CI: 1 7/8" X 16"</p> <p>ENTRADA: 1 5/16" SALIDA: 1 3/16"</p> <p>ENFRIDIADOR: NO</p> <p>088</p>	<p>A8225-44C FORD</p>  <p>BRONCO 1966-1977 V8 4.7/5.0 / L6 2.8 3.3</p> <p>8225 PHAR / DPI 0521</p> <p>PANAL: 19 1/4" X 18 8/9" X 1 3/4" CS: 2 9/16" X 19 13/16" CI: 2 9/16" X 19 13/16"</p> <p>ENFRIDIADOR: SI, 758225-M</p> <p>ENTRADA: 1 3/4" SALIDA: 1 1/2"</p> <p>089</p>	<p>A13022-60C FORD</p>  <p>Toma de Recuperador</p> <p>Tomas de candado</p> <p>DIESEL SUPER DUTY F-SERIES 08-10 V8 6.4</p> <p>DPI 13022</p> <p>PANAL: 36 7/8" X 27 3/8" X 2 3/8" CS: 2 5/8" X 28 1/8" CI: 3 5/8" X 28 1/8"</p> <p>ENTRADA: 1 7/8" SALIDA: 1 7/8"</p> <p>ENFRIDIADOR: SI</p> <p>090</p>

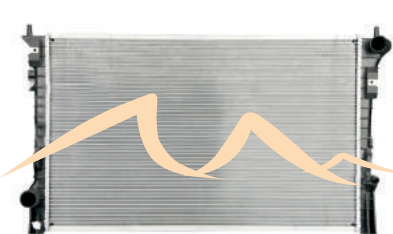
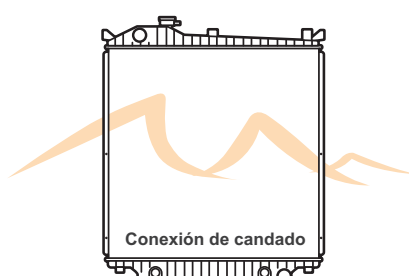
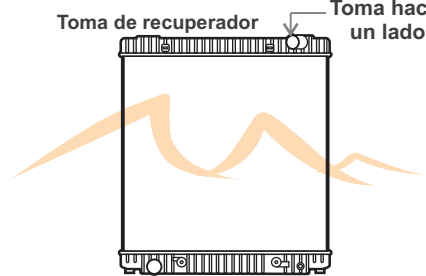
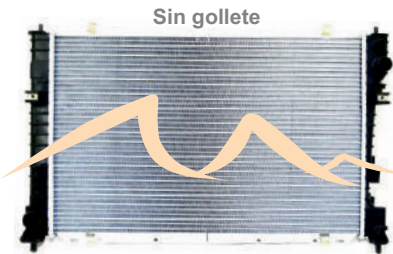

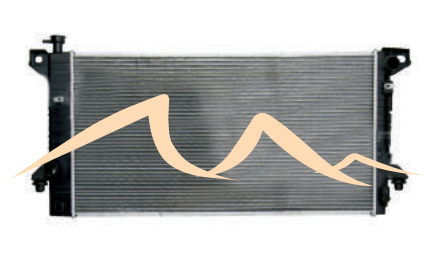
<p>A13087-13N FORD</p>  <p>FOCUS 08-11</p> <p>DPI 13087 L4 2.0</p> <p>PANAL: 26 3/4" X 16 5/8" X 1/2" CS: 1 9/16" X 17 5/16" CI: 1 9/16" X 17 5/16" EDA: NO</p> <p>CONDENSADOR: AC3672</p> <p>ENTRADA: 1" SALIDA: 1 5/16"</p> <p>091</p>	<p>0880 DPI FORD/MERCURY</p>  <p>TOPAZ/TEMPO 81-91</p> <p>5586 PHAR L4 1.9/2.0/2.3</p> <p>PANAL: 23 1/4" X 12 5/8" X 1 1/4" (32 mm) CS: 2 1/2" X 13 3/4" CI: 2 1/2" X 13 3/4" EDA: 8" EDAM: NO</p> <p>ENTRADA: 1 1/4" SALIDA: 1 1/4"</p> <p>092</p>	<p>0890 DPI FORD/MERCURY</p>  <p>TAURUS/SABLE 86-91</p> <p>2904 PHAR L4 2.5 V6 3.0</p> <p>PANAL: 24 1/8" X 14 7/8" X 1" (26 mm) CS: 2 1/2" X 15 1/8" CI: 2 1/2" X 15 1/8" EDA: 10" EDAM: NO</p> <p>ENTRADA: 1 1/2" SALIDA: 1 1/2"</p> <p>093</p>
<p>0891 DPI FORD/MERCURY</p>  <p>TAURUS/SABLE AMERICANA 86-89</p> <p>2904 PHAR V6 3.0</p> <p>PANAL: 24 1/8" X 15" X 2 1/8" CS: 3" X 15 1/8" CI: 3" X 15 1/8" EDA: 10" EDAM: NO</p> <p>ENTRADA: 1 1/2" SALIDA: 1 1/2"</p> <p>094</p>	<p>0893 DPI FORD</p>  <p>BRONCO/PICK UP AMERICANA 85-91</p> <p>3381 PHAR L6 4.9</p> <p>PANAL: 27 5/8" X 17 15/16" X 1" (26 mm) CS: 1 7/8" X 18 1/2" CI: 3" X 18 1/2" EDA: 1 3/4" X 12" EDAM: NO</p> <p>ENTRADA: 1 3/4" SALIDA: 1 1/4"</p> <p>095</p>	<p>0894 DPI FORD</p>  <p>BRONCO/PICK UP AMERICANA 85-92</p> <p>3381 PHAR L6 4.9</p> <p>PANAL: 27 1/2" X 18 1/2" X 1" (26 mm) CS: 1 7/8" X 18 1/2" CI: 1 7/8" X 18 1/2" EDA: NO EDAM: NO</p> <p>ENTRADA: 1 3/4" SALIDA: 1 3/4"</p> <p>NOTAS: Puede usar 893/1452/1454/1716</p> <p>096</p>
<p>0896 DPI FORD</p>  <p>BRONCO PICK UP 85-96</p> <p>3384 PHAR V8 5.0/5.8</p> <p>PANAL: 27 1/2" X 18 1/2" X 1" (26 mm) CS: 1 7/8" X 18 1/2" CI: 1 7/8" X 18 1/2" EDA: NO EDAM: NO</p> <p>ENTRADA: 1 3/4" SALIDA: 1 3/4"</p> <p>097</p>	<p>0897 DPI FORD/MAZDA</p>  <p>B3000/B4000/NAVAJO/BRONCO/EXPLORER 85-90/91-94</p> <p>6226 PHAR V6 2.9/3.0/4.0</p> <p>PANAL: 18" X 18 3/8" X 1" (26 mm) CS: 1 7/8" X 18 1/2" CI: 1 7/8" X 18 1/2" EDA: NO EDAM: NO</p> <p>ENTRADA: 1 1/2" SALIDA: 1 1/2"</p> <p>098</p>	<p>1115 DPI FORD</p>  <p>PROBE 90-92</p> <p>6226 PHAR V6 3.0</p> <p>PANAL: 15 3/4" X 27 1/4" X 1" (26 mm) CS: 1 7/8" X 27 1/2" CI: 1 7/8" X 27 1/2" EDA: 11 3/4"</p> <p>ENTRADA: 1 3/8" SALIDA: 1 3/8"</p> <p>099</p>

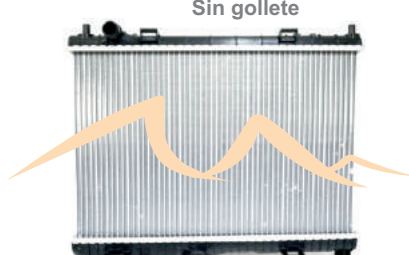
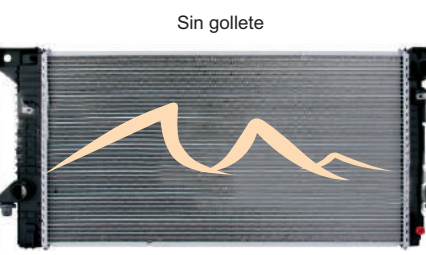
<p>1453 DPI FORD</p>  <p>BRONCO/F-SERIES 85-96</p> <p>3384 PHAR V8 5.0/5.8</p> <p>PANAL: 27 5/8" X 18 3/8" X 1 1/8" (28 mm) CS: 1 7/8" X 18 1/2" ENTRADA: 1 3/4" CI: 3" X 18 1/2" SALIDA: 1 3/4" EDA: 12" EDAM: NO</p> <p style="text-align: right;">100</p>	<p>1721 DPI FORD/MAZDA</p>  <p>RANGER/B4000 PICK UP 95-97</p> <p>6005 PHAR V6 4.0</p> <p>PANAL: 17 1/4" X 21 1/2" X 2 1/4" (56 mm) CS: 3" X 22" ENTRADA: 1 1/2" CI: 3" X 22" SALIDA: 1 1/2" EDA: 12" 7 PLACAS EDAM: NO</p> <p style="text-align: right;">101</p>	<p>1726 DPI FORD/MAZDA</p>  <p>B2300/RANGER 95-97</p> <p>5639 PHAR L4 2.3</p> <p>PANAL: 18" X 18 3/8" X 1" (26 mm) CS: 1 7/8" X 18 7/16" ENTRADA: 1 1/2" CI: 3 1/16" X 18 7/16" SALIDA: 1 5/8" EDA: SI 12"</p> <p style="text-align: right;">102</p>
<p>2018 DPI FORD</p>  <p>EXPLORER/RANGER 97-04</p> <p>6017 PHAR V6 3.0/4.0</p> <p>PANAL: 20 3/4" X 23 7/8" X 2 1/4" (56 mm) CS: 3" X 24" ENTRADA: 1 1/4" CI: 3" X 24" SALIDA: 1 1/4" EDA: 18" EDAM: NO</p> <p style="text-align: right;">103</p>	<p>2610 DPI FORD/LINCOLN/MERCURY</p>  <p>GRAND MARQUIS/CROWN VICTORIA/TOWN CAR 03-05</p> <p>6018 PHAR V8 4.6</p> <p>PANAL: 25 5/16" X 19 11/16" X 1" (26 mm) CS: 1 15/16" X 19 15/16" ENTRADA: 1 1/2" CI: 1 15/16" X 19 15/16" SALIDA: 1 1/2" EDA: NO EDAM: NO</p> <p style="text-align: right;">104</p>	<p>2741 DPI FORD</p>  <p>EXCURSION/PICK UP 03-05/04</p> <p>6019 PHAR V8 6.0</p> <p>PANAL: 28 7/16" X 30" X 1 3/8" CS: 3 3/16" X 30 1/2" ENTRADA: 1 3/4" CI: 3 3/16" X 30 1/2" SALIDA: 2" EDA: SI</p> <p style="text-align: right;">105</p>
<p>2762 DPI FORD/MERCURY/MAZDA</p>  <p>ESCAPE/TRIBUTE/MARINER 05-08</p> <p>DPI 2762 L4 2.3</p> <p>PANAL: 27 9/16" X 17 5/8" X 5/8" CAB. SUP.: 1 13/16" X 18 3/8" CAB. INF.: 1 13/16" X 18 3/8" Enfriador: NO</p> <p>TOMAS: ENTRADA: 1 1/4" SALIDA: 1 7/16"</p> <p style="text-align: right;">106</p>	<p>2819 DPI FORD/LINCOLN</p>  <p>EXPEDITION/F-SERIES PICK UP/MARK LT 05-08</p> <p>DPI 2819 V8 4.6/5.4</p> <p>PANAL: 31 7/8" X 16 7/8" X 1 7/16" (36 mm) CS: 3 1/8" X 17 7/8" ENTRADA: 1 1/4" CI: 2" X 17 7/8" SALIDA: 1 1/4" EDA: 12" 7 PLACAS EDAM: NO</p> <p style="text-align: right;">107</p>	<p>2887 DPI FORD</p>  <p>SUPER DUTY/F-SERIES PICK UP 05-08</p> <p>DPI 2887 V8 6.0 Diesel / V10 3.8 Gasolina</p> <p>PANAL: 28 4/9" X 30 1/8" X 1 3/8" CS: 3 3/16" X 30 1/2" ENTRADA: 1 3/4" CI: 3 3/16" X 30 1/2" SALIDA: 1 3/4" EDA: SI (7 PLACAS)</p> <p style="text-align: right;">108</p>

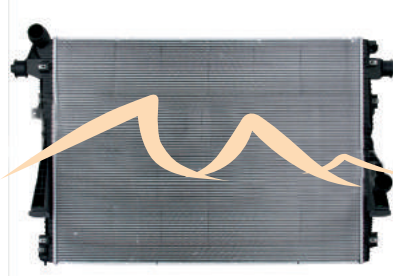
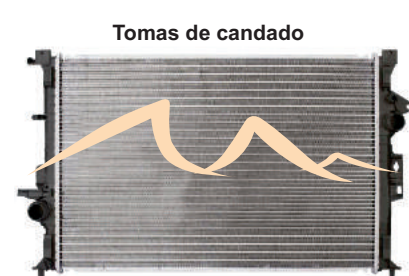
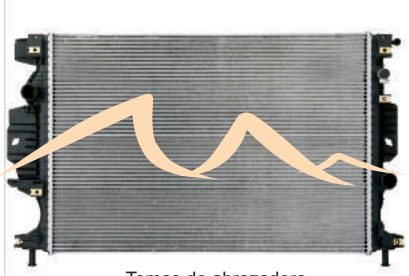
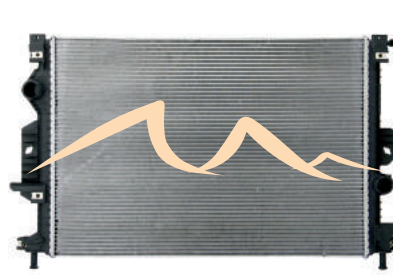
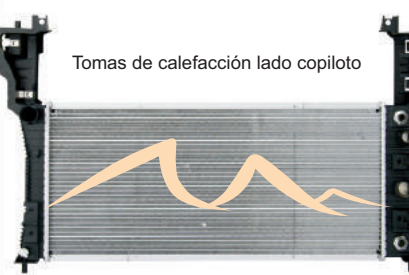
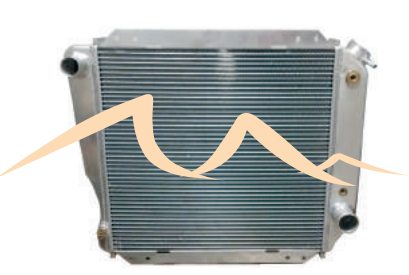
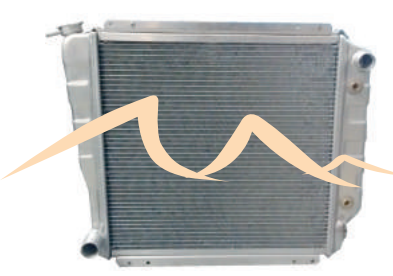
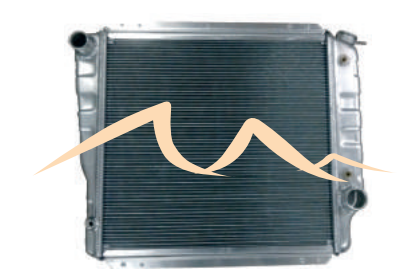
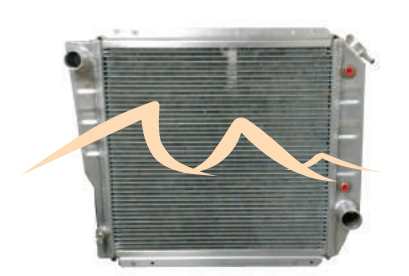
<p>2937 DPI FORD/MERCURY/LINCOLN</p>  <p>Doble toma lado piloto</p> <p>EDGE/TAURUS/MKS/MKX/SABLE 07-15</p> <p>DPI 2937 V6 3.5/3.7</p> <p>PANAL: 28 3/4" X 17 3/4" X 1" CAB. SUP.: 1 13/16" X 18 3/16" CAB. INF.: 1 13/16" X 18 3/16" Enfriador: NO</p> <p>TOMAS: ENTRADA: 1 1/2" SALIDA: 1 1/2"</p> <p>CONDENSADOR: AC3678 109</p>	<p>2952 DPI FORD/MERCURY</p>  <p>Conexión de candado</p> <p>S-TRAC/EXPLORER/MOUNTAINEER 07-10/07-10</p> <p>V6 4.0 V8 4.6</p> <p>PANAL: 24" X 23 1/2" X 1 1/4" (32 mm) CS: 3 1/8" X 24 3/16" CI: 3 1/8" X 24 3/16" EDA: SI (7 PLACAS)</p> <p>ENTRADA: 1 3/8" SALIDA: 1 3/8"</p> <p>110</p>	<p>2976 DPI FORD</p>  <p>Toma de recuperador Toma hacia un lado</p> <p>SUPER DUTY/E SERIES VAN 04-10</p> <p>V8 6.0</p> <p>PANAL: 23 9/16" X 25 3/4" X 1 7/16" (36 mm) CS: 3 3/16" X 26 3/4" CI: 3 3/16" X 26 3/4" EDA: SI 12* 7 PLACAS EDAM: NO</p> <p>ENTRADA: 1 3/4" SALIDA: 1 3/4"</p> <p>111</p>
<p>13041 DPI FORD/MERCURY/MAZDA</p>  <p>Sin gollete</p> <p>Sin enfriador</p> <p>ESCAPE 08-12/TRIBUTE08-11/MARINER 09-11</p> <p>V6 3.0</p> <p>PANAL: 27 9/16" X 17 11/16" X 1" CS: 1 7/8" X 18 1/2" CI: 1 7/8" X 18 1/2" EDA: NO EDAM: NO</p> <p>CONDENSADOR: AC3782 112</p>	<p>13060 DPI FORD/MERCURY/MAZDA</p>  <p>Sin gollete / Sin enfriador</p> <p>Toma de calefacción y recuperación al mismo lado</p> <p>ESCAPE 08-12/TRIBUTE 09-11/MARINER 09-11</p> <p>L4 2.3/2.5</p> <p>PANAL: 29 7/16" X 18 1/16" X 1" CS: 2" x 18 1/2" CI: 2" x 18 1/2" EDA: NO EDAM: NO</p> <p>ENTRADA: 1 5/16" SALIDA: 1 5/16"</p> <p>CONDENSADOR: AC3782 113</p>	<p>13099 DPI FORD/LINCOLN</p>  <p>EXPEDITION 09-14/F-SERIES 150, 250 09-10/ LOBO 2010/NAVIGATOR 09-14/MARK LT 2010</p> <p>V8 4.6/5.4/6.2</p> <p>PANAL: 31 1/2" X 16 1/2" X 1 1/4" CAB. SUP.: 2 9/16" X 17 5/8" CAB. INF.: 2 9/16" X 17 5/8" Enfriador: SI</p> <p>TOMAS: ENTRADA: 1 1/2" SALIDA: 1 9/16"</p> <p>CONDENSADOR: AC3618 114</p>
<p>13184 DPI FORD</p>  <p>Toma hacia abajo</p> <p>TRANSIT CONNECT 10-13</p> <p>DPI 13184 L4 2.0</p> <p>PANAL: 27 11/16" X 15 3/4" X 1 1/8" CAB. SUP.: 1 7/8" X 15 13/16" CAB. INF.: 1 7/8" X 15 13/16" Enfriador: NO</p> <p>TOMAS: ENTRADA: 1 3/8" SALIDA: 1 3/8"</p> <p>115</p>	<p>13201 DPI FORD</p>  <p>Sin gollete</p> <p>Toma inferior al centro</p> <p>FIESTA/IKON 08-15</p> <p>L4 1.6/2.0</p> <p>PANAL: 13 3/4" X 21 3/8" X 1 1/16" CS: 1 13/16" X 22 3/16" CI: 1 13/16" X 22 3/16" EDA: NO EDAM: NO</p> <p>ENTRADA: 1 1/8" SALIDA: 1 1/8"</p> <p>CONDENSADOR: AC3881 116</p>	<p>13226 DPI FORD/LINCOLN</p>  <p>Sin gollete</p> <p>Enfriador atrás lado piloto</p> <p>F-150/LOBO/MARK LT 11-14</p> <p>V6 3.5/3.7 / V8 5.0</p> <p>PANAL: 31 1/2" X 16 7/16" X 1 1/4" (32) CS: 2 9/16" X 17 5/8" CI: 2 9/16" X 17 5/8" EDA: SI PLACAS</p> <p>ENTRADA: 1 1/2" SALIDA: 1 9/16"</p> <p>CONDENSADOR: AC3618/AC3975 117</p>

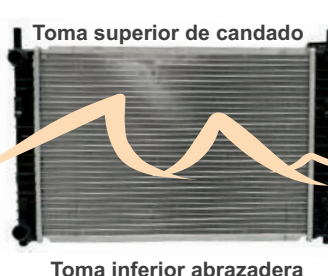
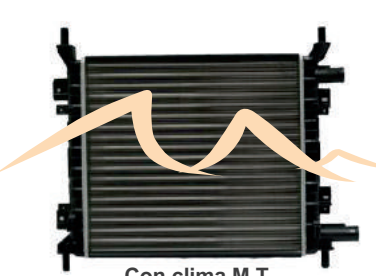
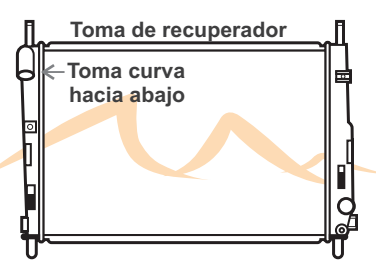
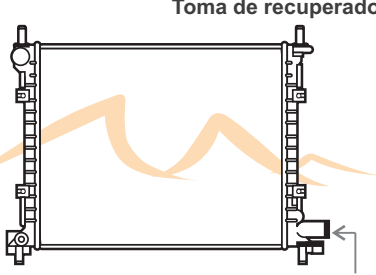
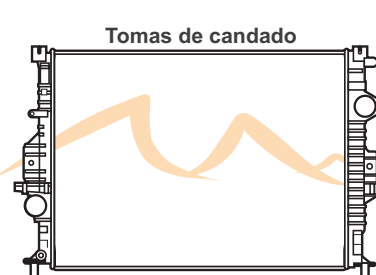
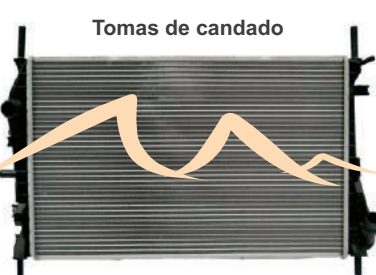
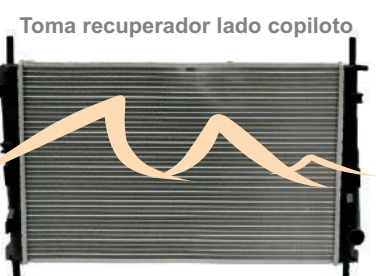
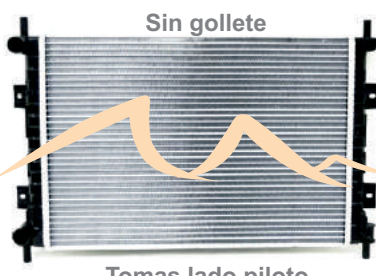
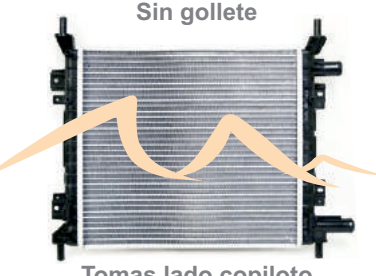
<p>13230-40 DPI FORD</p>  <p>Con tomas de candado</p> <p>F-SERIES 250, 350, 450, 550, SUPER DUTY 11-16 V8 6.7</p> <p>PANAL: 38 7/16" X 27 5/8" X 1 9/16" CAB. SUP.: 2 3/8" X 28 7/16" CAB. INF.: 2 3/8" X 28 7/16" Enfriador: NO</p> <p>TOMAS: ENTRADA: 2 3/16" SALIDA: 2 3/16"</p> <p>118</p>	<p>13313 DPI FORD</p>  <p>Tomas de candado</p> <p>ESCAPE/TRANSIT CONNECT 13-16 DPI 13313</p> <p>PANAL: 26 3/8" X 18 7/16" X 1" CAB. SUP.: 1 5/8" X 18 7/16" CAB. INF.: 1 5/8" X 18 7/16" Enfriador: NO</p> <p>TOMAS: ENTRADA: 1 1/2" SALIDA: 1 1/2"</p> <p>119</p>	<p>13321 DPI FORD/LINCOLN</p>  <p>Tomas de abrazadera</p> <p>FUSION/MKZ 13-16 L4 1.5/1.6/2.0/2.5</p> <p>PANAL: 26 7/16" X 18" X 1" (26) CS: 1 5/8" X 18 9/16" CI: 1 5/8" X 18 9/16" EDA: NO</p> <p>ENTRADA: 1 7/16" SALIDA: 1 7/16"</p> <p>120</p>
<p>13331 DPI FORD</p>  <p>Tomas de candado</p> <p>C-MAX HYBRID 13-15 L4 2.0 ELECTRIC-GAS</p> <p>PANAL: 26 7/16" X 18 1/8" X 1" (26) CS: 1 11/16" X 18 9/16" CI: 1 11/16" X 18 9/16" EDA: NO</p> <p>ENTRADA: 1 1/2" SALIDA: 1 1/2"</p> <p>121</p>	<p>13356 DPI FORD</p>  <p>Tomas de calefacción lado copiloto</p> <p>EDGE 12-14 L4 2.0</p> <p>PANAL: 26 3/8" X 11 11/16" X 1" (26) CS: 2" X 12 7/16" CI: 2" X 12 7/16" EDA: SI 10" PLACAS</p> <p>ENTRADA: 1 3/8" SALIDA: 1 7/16"</p> <p>122</p>	<p>AA060-60N FORD</p>  <p>Todo en aluminio</p> <p>TOMS BRONCO 66-77 L6 2.8/3.3 V8 4.7/5.0</p> <p>PANAL: 19" X 18 1/8" X 2 3/8" CS: 3" X 18 1/2" CI: 3" X 18 1/2" EDA: SI 10"</p> <p>ENTRADA: 1 1/2" SALIDA: 1 3/4"</p> <p>123</p>
<p>AA066-44C FORD</p>  <p>Todo en aluminio</p> <p>TOMS BRONCO 66-77 DPI 521 / 8225 PHAR</p> <p>PANAL: 19" X 18 15/16" X 1 3/4" CS: 18 15/16" X 2 3/8" CI: 18 15/16" X 2 3/8" EDA: SI 10"</p> <p>ENTRADA: 1 3/4" SALIDA: 1 1/2"</p> <p>124</p>	<p>AA067-44C FORD</p>  <p>Todo en aluminio</p> <p>TOMS BRONCO 66-77 V8 5.0/5.8</p> <p>PANAL: 19" X 18 15/16" X 1 3/4" CS: 18 15/16" X 2 3/8" CI: 18 15/16" X 2 3/8" EDA: SI 10"</p> <p>ENTRADA: 1 3/4" SALIDA: 1 1/2"</p> <p>125</p>	<p>AA068-60C FORD</p>  <p>Todo en aluminio</p> <p>TOMS BRONCO 66-77 L6 2.8/3.3 V8 4.7/5.0</p> <p>PANAL: 19" X 18 13/16" X 2 3/8" CS: 3" X 18 1/2" CI: 3" X 18 1/2" EDA: SI 10"</p> <p>ENTRADA: 1 1/2" SALIDA: 1 3/4"</p> <p>126</p>

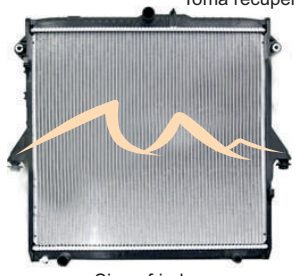
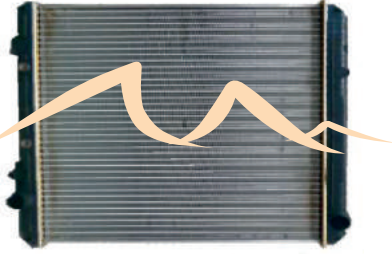
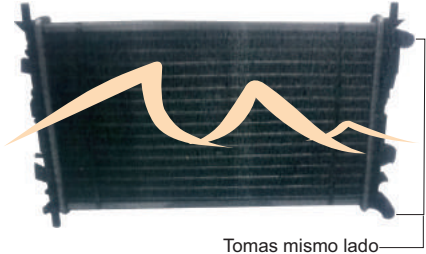
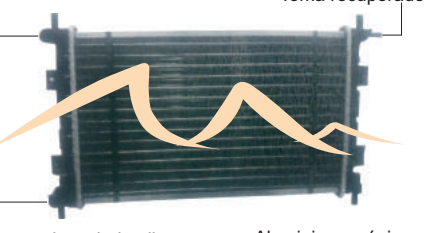
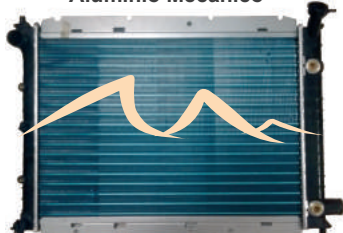
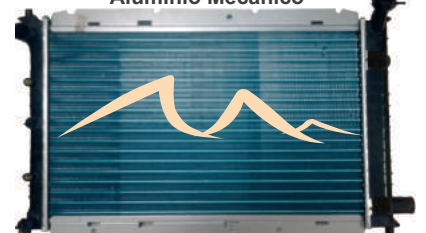
<p>FD-030 FORD</p>  <p>Toma superior de candado Toma inferior abrazadera</p> <p>FIESTA 02-08 L4 1.3 /1.4 TDCi</p> <p>PANAL: 19 5/8" X 13 3/16" X 7/8" CS: 1 9/16" X 14 3/8" CI: 1 9/16" X 14 3/8" EDA: NO</p> <p>ENTRADA: 1 5/16" SALIDA: 1 5/16"</p> <p>127</p>	<p>FD-042 FORD</p>  <p>Con clima M.T.</p> <p>KA 00-07 L4 1.0/1.1/1.3/1.4</p> <p>PANAL: 14 15/16" X 13 11/16" X 7/8" (22mm) CS: 1 5/8" X 14 3/16" CI: 1 5/8" X 14 3/16" EDA: NO</p> <p>ENTRADA: 1 1/16" SALIDA: 1 1/16"</p> <p>128</p>	<p>LHRP025-2R FORD</p>  <p>Toma de recuperador Toma curva hacia abajo</p> <p>MONDEO 00-04 L4 1.8/2.0/2.5</p> <p>IMPORTACION</p> <p>PANAL: 24 13/32" X 15 9/32" X 1" (26 mm) CS: 15 15/16" X 1 7/8" CI: 15 15/16" X 1 7/8" EDA: NO EDAM:</p> <p>ENTRADA: 1 5/16" SALIDA: 1 5/16"</p> <p>129</p>
<p>LHRP205-2R FORD</p>  <p>Toma de recuperador Toma hacia polvera</p> <p>FIESTA/IKON 00-07 L4 1.6</p> <p>7037 PHAR</p> <p>PANAL: 19 11/16" X 15 9/32" X 1" (26 mm) CS: 15 15/16" X 1 7/8" CI: 15 15/16" X 1 7/8" EDA: NO EDAM:</p> <p>ENTRADA: 1 9/32" SALIDA: 1 9/32"</p> <p>130</p>	<p>LHRP348-2R FORD</p>  <p>Tomas de candado</p> <p>MONDEO 06/07 L4 1.8</p> <p>PANAL: 24 13/32" X 18 27/64" X 1" (26 mm) CS: 18 1/2" X 1 11/16" CI: 18 1/2" X 1 11/16" EDA: NO EDAM:</p> <p>ENTRADA: 1 1/2" SALIDA: 1 1/2"</p> <p>131</p>	<p>LHRP499-26M FORD</p>  <p>Tomas de candado</p> <p>MONDEO 00-04 TDCi, TDDi L4 2.0/2.2</p> <p>PANAL: 24 3/8 X 15 5/8" X 1" CS: 15 15/16" X 1 7/8" CI: 15 15/16" X 1 7/8" EDA: NO EDAM:</p> <p>ENTRADA: 1 9/32" SALIDA: 1 9/32"</p> <p>132</p>
<p>LHRP500 FORD</p>  <p>Toma recuperador lado copiloto</p> <p>MONDEO 00-02 A.T. V6 2.5/3.0</p> <p>PANAL: 19 11/16" X 15 9/32" X 1" (26 mm) CS: 15 15/16" X 1 7/8" CI: 15 15/16" X 1 7/8" EDA: NO EDAM:</p> <p>ENTRADA: 1 9/32" SALIDA: 1 9/32"</p> <p>133</p>	<p>LHRP703 FORD</p>  <p>Sin gollete Tomas lado piloto</p> <p>COURIER 93-09 L4 1.6/2.0</p> <p>PANAL: 19 11/16" x 13 11/16" CS: 1 11/16" X 14 3/16" CI: 1 11/16" X 14 3/16" EDA: NO EDAM: NO</p> <p>ENTRADA: 1 1/16" SALIDA: 1 1/16"</p> <p>134</p>	<p>LHRP704 FORD</p>  <p>Sin gollete Tomas lado copiloto</p> <p>FIESTA/KA 00-07 L4 1.3/1.4</p> <p>PANAL: 14 15/16" X 13 11/16" X 7/8" CS: 1 5/8" X 14 3/16" CI: 1 5/8" X 14 3/16" EDA: NO EDAM: NO</p> <p>ENTRADA: 1 1/16" SALIDA: 1 1/16"</p> <p>135</p>

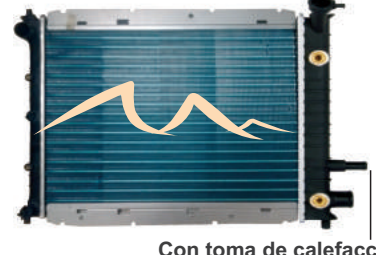
<p>LHRP946 FORD</p>  <p>Toma recuperador</p> <p>Sin enfriador</p> <p>RANGER 11-15 3.2L SUPER DIESEL</p> <p>PANAL: 23 7/8" X 25 1/8" X 1" (26) CS: 1 13/16" X 25 15/16" CI: 1 13/16" X 25 15/16" EDA: NO</p> <p>ENTRADA: 1 1/2" SALIDA: 1 1/4"</p> <p>136</p>	<p>MTC8238-52P5 FORD/FREIGHTLINER</p>  <p>Toma mismo lado</p> <p>CASCADIA 07-08 L6 12.8 / 14.8</p> <p>PANAL: 45 9/16" X 38" X 2" CAB. SUP.: 39 3/8" X 3 1/2" CAB. INF.: 39 3/8" X 3 1/2" ENF. TRANS.: SI ENF. MOTOR: NO</p> <p>TOMAS: ENTRADA: 2 1/2" SALIDA: 2 1/2"</p> <p>137</p>	<p>M008-26N FORD</p>  <p>Tomas mismo lado</p> <p>FIESTA/ECOSPORT 03-09 L4 1.6/2.0</p> <p>PANAL: 22" X 13 1/4" X 1" CS: 14 3/16" X 1 5/8" CI: 14 3/16" X 1 5/8" EDA: NO</p> <p>ENTRADA: 1 1/16" SALIDA: 1 1/16"</p> <p>138</p>
<p>M036-26N FORD</p>  <p>Toma recuperador</p> <p>Tomas mismo lado piloto</p> <p>Aluminio mecánico</p> <p>COURIER PICK UP 93-09 L4 1.6/2.0</p> <p>PANAL: 19 5/8" X 13 1/2" X 1" CS: 14 3/16" X 1 5/8" CI: 14 3/16" X 1 5/8" EDA: NO</p> <p>ENTRADA: 1 1/16" SALIDA: 1 1/16"</p> <p>139</p>	<p>M1273-26C FORD/MERCURY</p>  <p>Aluminio Mecánico</p> <p>Sin tomas de calefacción</p> <p>ESCORT 91-02/TRACER 91-99 DPI 1273 / 5589 PHAR L4 1.8/1.9/2.0</p> <p>PANAL: 21 5/8" X 16" X 1" CAB. SUP.: 1 7/8" X 17 1/8" CAB. INF.: 1 7/8" X 17 1/8" ENFRIADOR: SI</p> <p>TOMAS: ENTRADA: 1 3/8" SALIDA: 1 3/8"</p> <p>140</p>	<p>M1274-26N FORD/MERCURY</p>  <p>Aluminio Mecánico</p> <p>Toma hacia polvera</p> <p>ESCORT 91-02/TRACER 91-99 5589 PHAR L4 1.8/1.9/2.0</p> <p>PANAL: 21 5/8" X 15.635" X 1" CAB. SUP.: 1 7/8" X 17 1/8" CAB. INF.: 1 7/8" X 17 1/8" ENFRIADOR: NO</p> <p>TOMAS: ENTRADA: 1 3/8" SALIDA: 1 3/8"</p> <p>141</p>
<p>M2138-26C FORD</p>  <p>Sin gollete usar M2139-26C</p> <p>Aluminio Mecánico</p> <p>MUSTANG 97-04 6236 PHAR V6 3.8/3.9</p> <p>PANAL: 24 15/16" X 15 7/8" X 1" CAB. SUP.: 17 3/16" X 1 13/16" CAB. INF.: 17 3/16" X 3" ENFRIADOR: SI</p> <p>TOMAS: ENTRADA: 1 1/2" SALIDA: 1 3/4"</p> <p>142</p>	<p>M2139-26C FORD</p>  <p>Con gollete usar M2138-26C</p> <p>Aluminio Mecánico</p> <p>MUSTANG 97-04 DPI 2139/3387 PHAR V8 4.6</p> <p>PANAL: 24 3/4" X 15 7/8" X 1" CAB. SUP.: 17 3/16" X 1 13/16" CAB. INF.: 17 3/16" X 3" ENFRIADOR: SI</p> <p>TOMAS: ENTRADA: 1 1/2" SALIDA: 1 3/4"</p> <p>143</p>	<p>M2140-26C FORD</p>  <p>Aluminio Mecánico</p> <p>Con toma de calefacción</p> <p>ESCORT ZX2 DPI 2140 / 6038 PHAR L4 2.0</p> <p>PANAL: 21 5/8" X 16" X 1" CAB. SUP.: 1 7/8" X 17 1/8" CAB. INF.: 1 7/8" X 17 1/8" ENFRIADOR: SI</p> <p>TOMAS: ENTRADA: 1 3/8" SALIDA: 1 3/8"</p> <p>144</p>

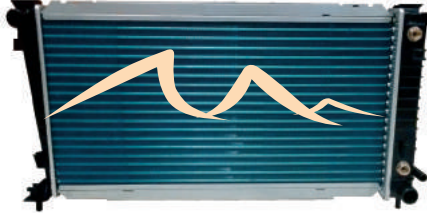
M2141-26C	FORD	M2258-26P7	FORD	M2296-26N	FORD
<p>Toma de recuperador</p>  <p>Tubo mecánico</p>		<p>Toma de recuperador</p>  <p>Tubo mecánico</p>		<p>Sin toma de calefacción usar A2297-28N</p>  <p>Aluminio mecánico</p>	
<p>F-SERIES 97-98/EXPEDITION 97-98/LOBO 01-02</p> <p>DPI 2141 / 3385 PHAR V8 4.2/4.6</p> <p>PANAL: 32" X 15 5/8" X 1" CAB. SUP.: 1 13/16" X 17 1/8" CAB. INF.: 3" X 17 1/8" ENFRIADOR: SI</p> <p>TOMAS: ENTRADA: 1 3/4" SALIDA: 1 3/4"</p> <p style="text-align: right;">145</p>		<p>FREESTAR 04-07/WINDSTAR 99-03/MONTEREY 04-07</p> <p>DPI 2258 / 6011 PHAR V6 3.0/3.8/3.9/4.2</p> <p>PANAL: 30" X 15 5/8" X 1" CAB. SUP.: 1 13/16" X 17 1/8" CAB. INF.: 3" X 17 1/8" ENFRIADOR: SI</p> <p>TOMAS: ENTRADA: 1 1/2" SALIDA: 1 1/2"</p> <p style="text-align: right;">146</p>		<p>FOCUS/ZX3 00-07</p> <p>DPI 2296 L4 2.0/2.3</p> <p>PANAL: 23 1/2" X 13 5/16" X 1" CAB. SUP.: 14 7/16" X 1 15/16" CAB. INF.: 14 7/16" X 1 15/16" ENF. TRANS.: NO</p> <p>TOMAS: ENTRADA: 1 1/4" SALIDA: 1 1/4"</p> <p style="text-align: right;">147</p>	

M2818-26P7	FORD	A8022-44N	FREIGHTLINER	<p>PRUEBA NUESTRA VERSION IMPRESA EN LINEA</p>  <p style="text-align: center;">www.phar.com.mx</p>	
<p>Tubo mecánico</p>  <p>Conexiones de candado</p>		<p>Versión aluminio/plástico incluye laterales</p> 			
<p>EXPEDITION/F-SERIES/MARK LT/LOBO/NAVIGATOR 05-08</p> <p>V6 4.2 V8 4.6/5.4</p> <p>PANAL: 32" X 15 5/8" X 1" CAB. SUP.: 1 13/16" X 17 1/8" CAB. INF.: 3" X 17 1/8" ENFRIADOR: SI</p> <p>TOMAS: ENTRADA: 1 3/4" SALIDA: 1 1/2"</p> <p style="text-align: right;">148</p>		<p>BUSINESS CLASS M2 04-12 / CENTURY CLASS C112-C120 96-01</p> <p>PHAR 8022 L6 5.9/8.3/10.3/10.8/12.0/12.7</p> <p>PANAL: 42 1/2" X 29" X 4 15/16" CAB. SUP.: 28 7/8" X 3 7/16" CAB. INF.: 28 7/8" X 3 7/16" Enfriador: NO</p> <p>TOMAS: ENTRADA: 2 1/2" SALIDA: 2 1/2"</p> <p style="text-align: right;">149</p>			

Escanea nuestro código QR con tu smartphone

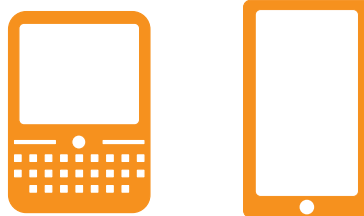

Descarga la aplicación desde tu Smartphone en: www.2dscan.com



Radiadores

PHAR

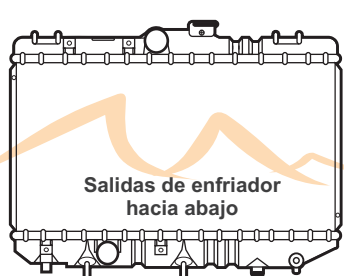
- **GEO**
- **HONDA**
- **HYUNDAI**

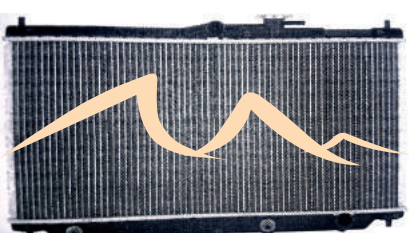
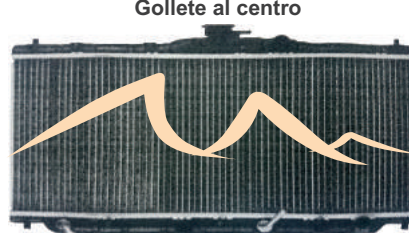
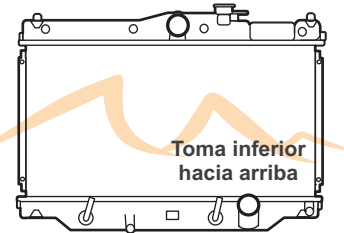
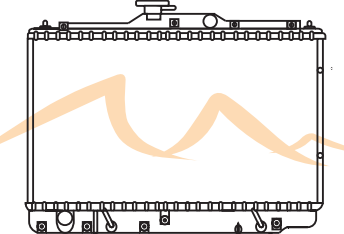
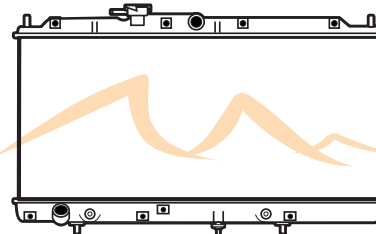
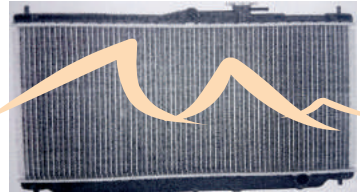
<p>1409 DPI GEO / TOYOTA</p>  <p>Salidas de enfriador hacia abajo</p> <p>COROLLA/PRIZM 93-97</p> <p>L4 1.6/1.8</p> <p>PANAL: 13 3/4" X 27 1/2" X 1" (26 mm) CS: 1 7/8" X 28 1/4" ENTRADA: 1 1/4" CI: 1 7/8" X 28 1/4" SALIDA: 1 1/4" EDA: 8 7/8" EDAM: NO NOTAS: Substituye 1436/1462</p> <p>001</p>	<p>2089 DPI GEO/SUZUKI</p>  <p>Enfriador hacia abajo</p> <p>TRACKER X-90 94-98</p> <p>L4 1.6</p> <p>DPI 2089 / 6132 PHAR</p> <p>PANAL: 14 7/8" X 19 3/16" X 1 1/4" CAB. SUP.: 1 15/16" X 19 15/16" TOMAS: CAB. INF.: 1 15/16" X 19 15/16" ENTRADA: 1 1/8" Enfriador: NO SALIDA: 1 1/8"</p> <p>002</p>	<p>2198 DPI GEO/TOYOTA/CHEVROLET</p>  <p>Salidas de enfriador hacia abajo de espiga</p> <p>COROLLA/PRIZM 98-02</p> <p>L4 1.8</p> <p>PANAL: 13 3/4" X 25 1/4" X 5/8" (16 mm) CS: 1 7/8" X 25 11/16" ENTRADA: 1 1/4" CI: 1 7/8" X 25 11/16" SALIDA: 1 1/4" EDA: 8 7/8" EDAM: NO</p> <p>003</p>
<p>A0019-28C HONDA</p>  <p>ACCORD 90-93/PRELUDE 92-96</p> <p>L4 2.2</p> <p>DPI 0019</p> <p>PANAL: 19" X 27 3/16" X 3 7/8" CAB. SUP.: 27 1/16" X 1 15/16" CAB. INF.: 27 1/16" X 1 15/16" ENFRIADOR: SI</p> <p>TOMAS: ENTRADA: 1 1/4" SALIDA: 1 1/4"</p> <p>004</p>	<p>A0928-28C HONDA</p>  <p>Gollete al centro</p> <p>Base para sensor</p> <p>ACCORD 86-89</p> <p>L4 2.0</p> <p>DPI 928 / 4672 PHAR</p> <p>PANAL: 12 7/8" X 26 1/8" X 1 1/8" CAB. SUP.: 2" X 27" CAB. INF.: 2" X 27" ENF. TRANS.: SI ENF. MOTOR: NO</p> <p>TOMAS: ENTRADA: 1 1/8" SALIDA: 1 1/8"</p> <p>005</p>	<p>A1494-13C HONDA/ACURA</p>  <p>Toma inferior hacia arriba</p> <p>PRELUDE/CL/ACCORD 94-97</p> <p>L4 2.2/2.3</p> <p>7022 PHAR / DPI 1494</p> <p>PANAL: 13 3/4" X 26 53/64" X 1/2" CS: 1 3/8" X 27 1/2" ENTRADA: 1 1/4" CI: 2" X 27 1/2" SALIDA: 1 1/4" ENFRIADOR: SI 756522</p> <p>006</p>
<p>A1776-13C HONDA/ACURA</p>  <p>Toma hacia arriba</p> <p>ACCORD 95-97/ACURA CL 97-99</p> <p>V6 2.7/3.0</p> <p>DPI 1776 / 7028 PHAR</p> <p>PANAL: 14 13/16" X 26 3/4" X 1/2" CS: 1 15/16" X 27 1/2" ENTRADA: 1 1/4" CI: 1 7/8" X 27 1/2" SALIDA: 1 1/4" ENFRIADOR: SI</p> <p>007</p>	<p>A1776-28C HONDA/ACURA</p>  <p>Toma hacia arriba</p> <p>ACCORD/ACURA CL 95-97/97-99</p> <p>V6 2.7/3.0</p> <p>DPI 1776 / 7028 PHAR</p> <p>PANAL: 14 13/16" X 26 3/4" X 1 1/8" (26 mm) CS: 1 3/8" X 26 3/4" ENTRADA: 1 1/4" CI: 1 5/8" X 26 3/4" SALIDA: 1 1/4" ENFRIADOR: SI</p> <p>008</p>	<p>A1940-28N HONDA</p>  <p>Con enfriador usar A0019-28C</p> <p>ACCORD 91-93/PRELUDE 92-96</p> <p>L4 2.2</p> <p>PANAL: 19" X 27 3/16" X 3 7/8" CAB. SUP.: 27 1/16" X 1 15/16" TOMAS: CAB. INF.: 27 1/16" X 1 15/16" ENTRADA: 1 1/4" EDA: NO SALIDA: 1 1/4"</p> <p>009</p>

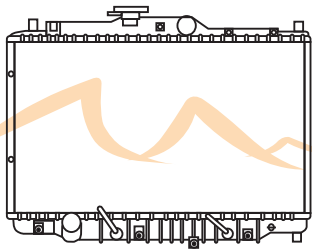
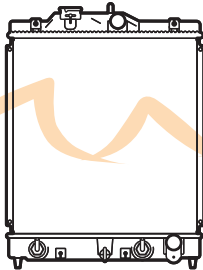
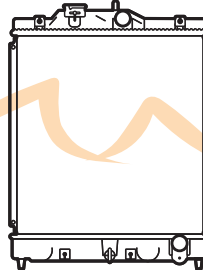
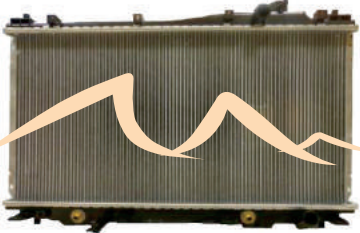
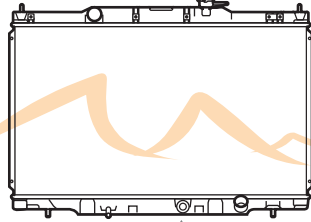
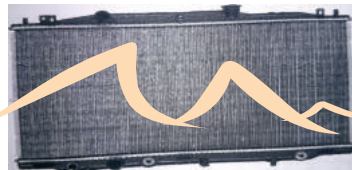
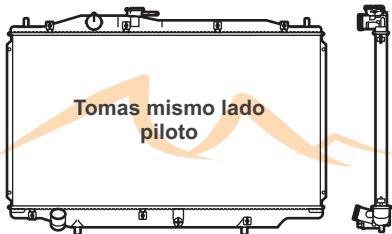
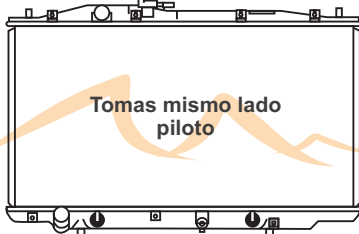
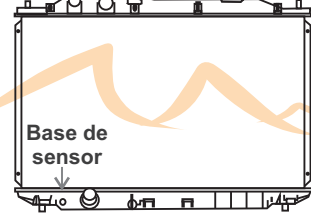
<p>A2147-13C HONDA</p>  <p>Toma hacia arriba</p> <p>ACURA TL 99-01/ACCORD 98-02</p> <p>DPI 2147 V6 3.0/3.2</p> <p>PANAL: 15 3/4" X 28 1/16" X 1/2" CS: 1 15/16" X 28 15/16" ENTRADA: 1 1/4" CI: 1 15/16" X 28 15/16" SALIDA: 1 1/4"</p> <p>ENFRIADOR: SI</p> <p>010</p>	<p>A2274-28C HONDA/ACURA</p>  <p>EL 97-00/CIVIC 92-00</p> <p>DPI 2274 / 6206 PHAR L4 1.5/1.6</p> <p>PANAL: 13 3/4" X 13 15/16" X 1 1/8" CS: 1 7/8" X 14 5/8" ENTRADA: 1 1/8" CI: 1 7/8" X 14 5/8" SALIDA: 1 1/8"</p> <p>ENFRIADOR: SI</p> <p>011</p>	<p>A2274-28N HONDA</p>  <p>EL 97-0/CIVIC 92-00</p> <p>DPI 2274 / 6206 PHAR L4 1.5/1.6</p> <p>PANAL: 13 3/4" X 13 15/16" X 1 1/8" CS: 1 7/8" X 14 5/8" ENTRADA: 1 1/8" CI: 1 7/8" X 14 5/8" SALIDA: 1 1/8"</p> <p>ENFRIADOR: NO</p> <p>012</p>
<p>A2354-13C HONDA</p>  <p>CIVIC/ACURA/EL 01-05</p> <p>L4 1.7</p> <p>PANAL: 13 3/4" X 25 7/8" X 1/2" CAB. SUP.: 1 5/16" X 26 11/16" CAB. INF.: 1 9/16" X 26 11/16" ENF. TRANS.: SI 12 7/8" ENF. MOTOR: NO CONDENSADOR: AC4977</p> <p>TOMAS: ENTRADA: 1 1/8" SALIDA: 1 1/8"</p> <p>013</p>	<p>A2443-13C HONDA</p>  <p>Base para sensor y Toma hacia arriba</p> <p>ELEMENT/CR-V 02-06</p> <p>DPI 2443 L4 2.4</p> <p>PANAL: 15 3/4" X 28 11/16" X 1/2" CS: 1 7/8" X 29 3/4" CI: 1 7/8" X 29 3/4"</p> <p>ENTRADA: 1 1/2" SALIDA: 1 1/2"</p> <p>ENFRIADOR: SI CONDENSADOR: AC3112</p> <p>014</p>	<p>A2569-13C HONDA</p>  <p>Base para sensor tanque inferior</p> <p>Tomas lineales lado piloto</p> <p>ACCORD 03-04</p> <p>DPI 2569 L4 2.4</p> <p>PANAL: 20 3/8" X 29 1/8" X 3 3/8" CAB. SUP.: 28 15/16" X 1 5/16" CAB. INF.: 28 15/16" X 1 5/16" Enfriador: SI</p> <p>TOMAS: ENTRADA: 1 1/4" SALIDA: 1 1/4"</p> <p>015</p>
<p>A2571-13N HONDA</p>  <p>Tomas mismo lado piloto</p> <p>Sin enfriador</p> <p>M/T ACCORD 03-07</p> <p>DPI 2571 GAS V6 3.0</p> <p>PANAL: 14 3/4" X 27 3/4" X 1/2" CS: 1 7/8" X 28 15/16" CI: 1 7/8" X 28 15/16" EDA: NO</p> <p>ENTRADA: 1 1/4" SALIDA: 1 1/4"</p> <p>016</p>	<p>A2783-13C HONDA</p>  <p>Tomas mismo lado piloto</p> <p>Con enfriador</p> <p>A/T ACCORD 05-07</p> <p>DPI 2783 Electrico/Gas V6 3.0</p> <p>PANAL: 14 3/4" X 27 3/4" X 1/2" CS: 1 7/8" X 28 15/16" CI: 1 7/8" X 28 15/16"</p> <p>ENTRADA: 1 1/4" SALIDA: 1 1/4"</p> <p>ENFRIADOR: SI</p> <p>017</p>	<p>A2922-13N HONDA/ACURA</p>  <p>Doble toma</p> <p>Base de sensor</p> <p>Toma de candado hacia arriba</p> <p>CIVIC 06-11/ACURA CSX 06-11</p> <p>DPI 2922 L4 1.8/2.0 M/T</p> <p>PANAL: 14 3/4" X 26 1/2" X 1/2" CS: 2" X 27 9/16" CI: 2" X 27 9/16"</p> <p>ENTRADA: 1 1/4" SALIDA: 1 1/4"</p> <p>ENFRIADOR: NO CONDENSADOR: AC3525/AC3569</p> <p>018</p>

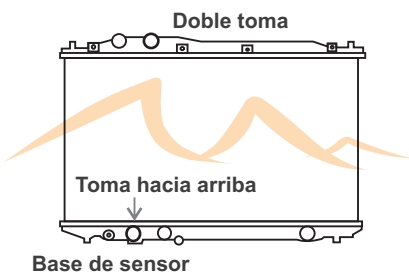
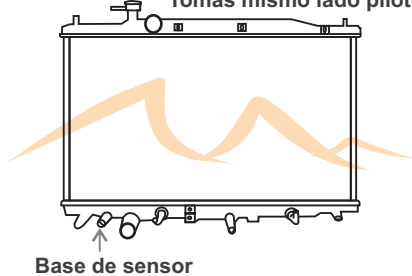
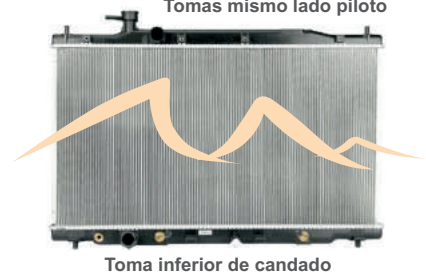
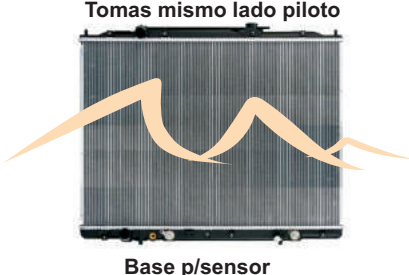
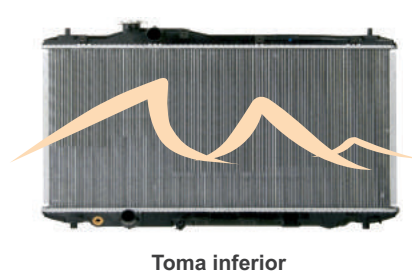
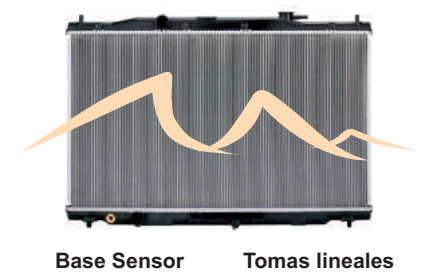
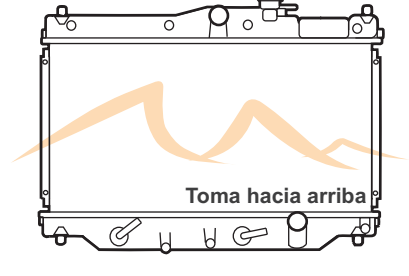
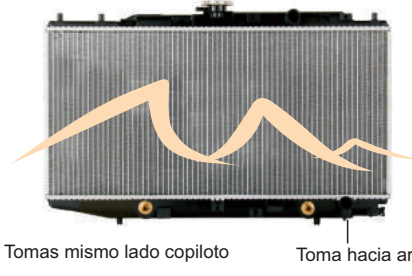
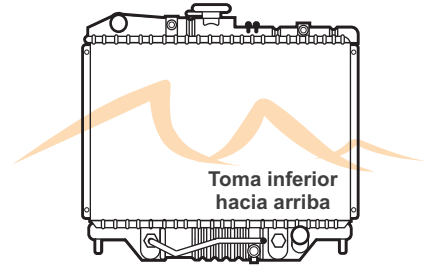
<p>A2923-13C HONDA</p>  <p>CIVIC 06-11/ACURA CSX 06-11</p> <p>DPI 2923 L4 1.3/2.0 A/T</p> <p>PANAL: 14 3/4" X 26 1/2" X 1/2" CS: 1 9/16" X 27 3/8" ENTRADA: 1 1/4" CI: 1 9/16" X 27 3/8" SALIDA: 1 1/4"</p> <p>ENFRIADOR: SI CONDENSADOR: AC3525 019</p>	<p>A2954-13C HONDA</p>  <p>CRV 07-09</p> <p>DPI 2954 L4 2.4</p> <p>PANAL: 15 3/4" X 28 1/4" X 1/2" CS: 2" X 29 1/2" ENTRADA: 1 1/4" CI: 2" X 29 1/2" SALIDA: 1 1/4"</p> <p>ENFRIADOR: SI CONDENSADOR: AC3599 020</p>	<p>A13031-13C HONDA</p>  <p>CR-V 07-09</p> <p>DPI 2954 L4 2.4</p> <p>PANAL: 15 3/4" X 28 11/16" X 1/2" CS: 2" X 29 1/2" ENTRADA: 1 1/4" CI: 2" X 29 1/2" SALIDA: 1 1/4"</p> <p>EDA: SI EDAM: NO CONDENSADOR: AC3599 021</p>
<p>A13065-28C HONDA</p>  <p>PILOT / RIDGELINE 09-15</p> <p>DPI 13065 V6 3.5</p> <p>PANAL: 21 5/8" X 30 1/16" X 1 1/8" CAB. SUP.: 31 1/4" X 1 7/8" ENTRADA: 1 1/4" CAB. INF.: 31 1/4" X 1 7/8" SALIDA: 1 1/4"</p> <p>ENFRIADOR: SI, 14 3/4" 752817-M CONDENSADOR: AC3771 022</p>	<p>A13221-13N HONDA/ACURA</p>  <p>CIVIC 12-15 / ILX 13-15</p> <p>DPI 13221 L4 1.8/2.4</p> <p>PANAL: 14 3/4" X 26 3/8" X 1/2" CAB. SUP.: 1 5/16" X 27" CAB. INF.: 1 15/16" X 27" ENF. TRANS.: NO ENF. MOTOR: NO</p> <p>TOMAS: ENTRADA: 1 1/4" SALIDA: 1 1/4"</p> <p>023</p>	<p>A13314-13N HONDA</p>  <p>CR-V 12-16</p> <p>DPI 13314 L4 2.4</p> <p>PANAL: 16 3/4" X 28 7/16" X 1/2" CS: 29 3/4" X 1 1/4" ENTRADA: 1 5/16" CI: 29 3/4" X 1 7/8" SALIDA: 1 5/16"</p> <p>ENFRIADOR: NO CONDENSADOR: AC3997 024</p>
<p>0019 DPI HONDA</p>  <p>PRELUDE 92-96/ACCORD 90-93</p> <p>L4 2.2</p> <p>PANAL: 13 3/4" X 26 1/4" X 1" (26 mm) CS: 2" X 27" ENTRADA: 1 1/4" CI: 2" X 27" SALIDA: 1 1/4"</p> <p>EDA: 12 3/4" EDAM: NO NOTAS: Sustituye M/T 1940 025</p>	<p>0886 DPI HONDA</p>  <p>CIVIC-CRX 88-91</p> <p>L4 1.5/1.6</p> <p>PANAL: 12 3/4" X 26 1/4" X 5/8" (16) CS: 1 7/16" X 27 1/8" ENTRADA: 1 1/8" CI: 1 7/8" X 27 1/8" SALIDA: 1 1/8"</p> <p>EDA: NO 026</p>	<p>1571 DPI HONDA/SUZU</p>  <p>PASSPORT 94-97/RODEO 93-01</p> <p>V6 3.2/3.5</p> <p>PANAL: 16 3/4" X 24 1/4" X 5/8" (16 mm) CS: 2" X 25" ENTRADA: 1 1/2" CI: 2" X 25" SALIDA: 1 1/2"</p> <p>EDA: SI EDAM: NO 027</p>

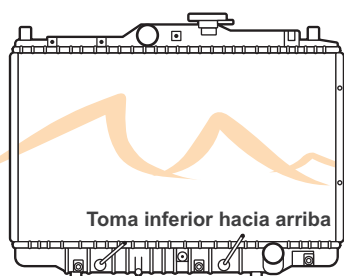
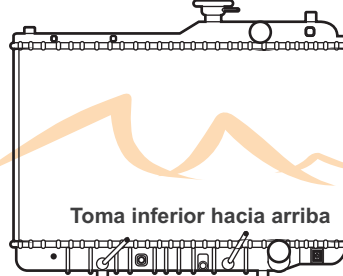
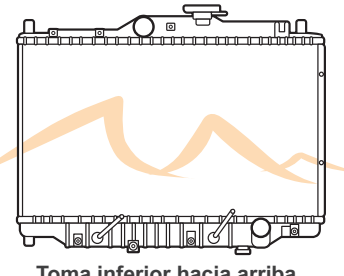
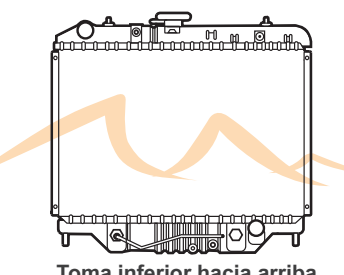
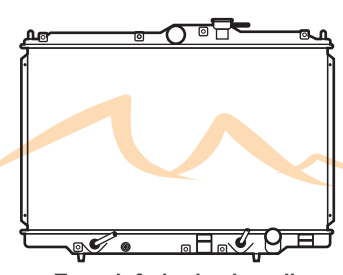
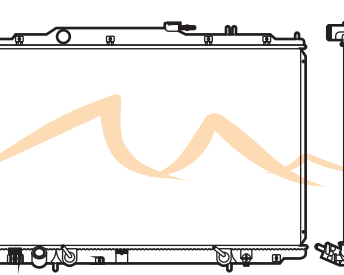
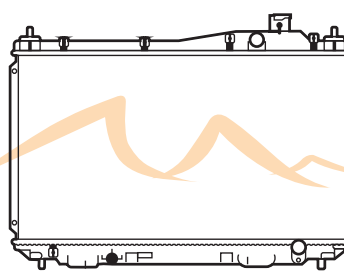
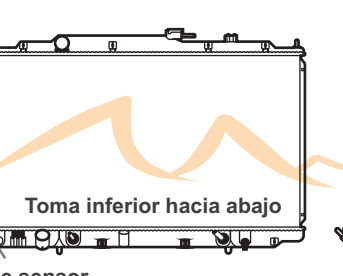
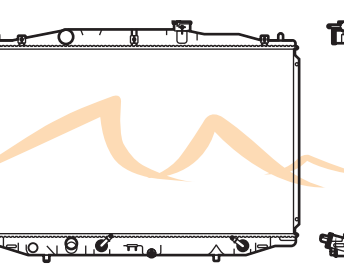
<p>1815 DPI HONDA/ISUZU</p>  <p>Toma inferior hacia arriba</p> <p>OASIS 96-98/ODYSSEY 95-98 L4 2.2/2.3</p> <p>PANAL: 16 3/4" X 26 3/4" X 1" (26 mm) CS: 2" X 27 1/2" ENTRADA: 1 1/4" CI: 2" X 27 1/2" SALIDA: 1 1/4" EDA: 12 3/4" EDAM: NO</p> <p style="text-align: right;">028</p>	<p>2051 DPI HONDA</p>  <p>Toma inferior hacia arriba</p> <p>CRV 97-01 L4 2.0</p> <p>PANAL: 13 3/4" X 26 1/4" X 5/8" (16 mm) CS: 1 3/8" X 26 3/4" ENTRADA: 1 1/4" CI: 1 7/8" X 26 3/4" SALIDA: 1 1/4" EDA: 12 3/4" EDAM: NO</p> <p>NOTAS: También en 16 mm (5/8") 1 Línea</p> <p style="text-align: right;">029</p>	<p>2148 DPI HONDA</p>  <p>Toma inferior hacia arriba</p> <p>ACCORD 98-02 L4 2.3</p> <p>PANAL: 14 3/4" X 26 3/4" X 5/8" (16 mm) CS: 1 5/16" X 27 1/16" ENTRADA: 1 1/4" CI: 1 7/8" X 27 1/16" SALIDA: 1 1/4" EDA: 12 3/4" EDAM: NO</p> <p style="text-align: right;">030</p>
<p>2195 DPI HONDA/ISUZU</p>  <p>Toma inferior hacia arriba</p> <p>PASSAPORT/RODEO 98-043 V6 3.2/3.5</p> <p>PANAL: 16 3/4" X 24 1/4" X 1 1/4" (32 mm) CS: 2 1/16" X 25 1/16" ENTRADA: 1 1/2" CI: 2 1/16" X 25 1/16" SALIDA: 1 1/2" EDA: 13 3/4" EDAM: NO</p> <p style="text-align: right;">031</p>	<p>2203 DPI HONDA</p>  <p>Toma inferior hacia arriba</p> <p>ACCORD 98-02 L4 2.3</p> <p>PANAL: 14 3/4" X 26 11/16" X 5/8" (16 mm) CS: 1 11/16" X 27 3/16" ENTRADA: 1 1/4" CI: 1 11/16" X 27 3/16" SALIDA: 1 1/4" EDA: 12 13/16" EDAM: NO</p> <p style="text-align: right;">032</p>	<p>2270 DPI HONDA/ISUZU</p>  <p>Toma inferior hacia arriba</p> <p>OASIS 99/ODYSSEY 99-04 L4 2.3 V6 3.5</p> <p>PANAL: 17 11/16" X 30 1/4" X 5/8" (16 mm) CS: 1 5/16" X 31 1/4" ENTRADA: 1 1/4" CI: 1 7/8" X 31 1/4" SALIDA: 1 1/4" EDA: 14 3/4" EDAM: NO</p> <p style="text-align: right;">033</p>
<p>2355 DPI HONDA</p>  <p>Toma inferior hacia abajo</p> <p>M/T EL 01-05/CIVIC 01-05 L4 1.7</p> <p>PANAL: 13 3/4" X 25 7/8" X 5/8" (16 mm) CS: 1 5/16" X 26 11/16" ENTRADA: 1 1/8" CI: 1 9/16" X 26 11/16" SALIDA: 1 1/8" EDA: NO EDAM: NO MAQ: 1.7 L4 M/T</p> <p style="text-align: right;">034</p>	<p>2417 DPI HONDA/ACURA</p>  <p>Toma inferior hacia abajo</p> <p>Base sensor</p> <p>PILOT/MDX 03-04 V6 3.5</p> <p>PANAL: 19 11/16" X 31 1/8" X 5/8" (16 mm) CS: 1 3/8" X 31 1/4" ENTRADA: 1 1/2" CI: 1 3/8" X 31 1/4" SALIDA: 1 1/2" EDA: 14 3/4" EDAM: NO</p> <p>CONDENSADOR: AC3182</p> <p style="text-align: right;">035</p>	<p>2569 DPI HONDA</p>  <p>Toma inferior hacia abajo</p> <p>ACCORD 03-04 L4 2.4</p> <p>PANAL: 15 3/4" X 28 1/4" X 5/8" (16 mm) CS: 1 5/16" X 28 15/16" ENTRADA: 1 5/16" CI: 1 7/8" X 28 15/16" SALIDA: 1 5/16" EDA: 12 13/16" EDAM: NO</p> <p style="text-align: right;">036</p>

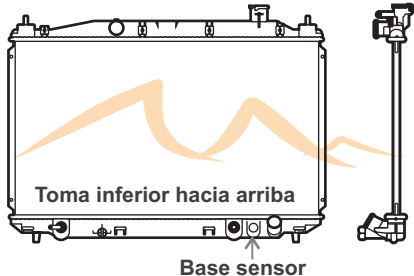
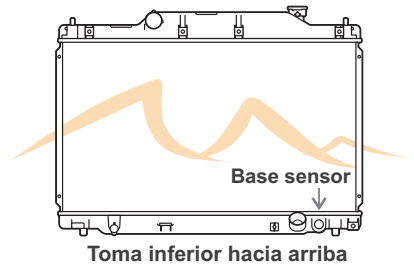
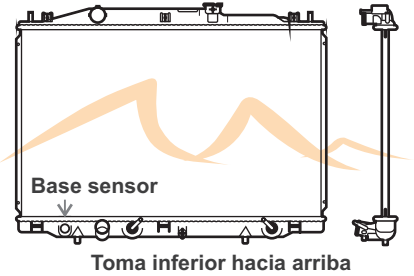
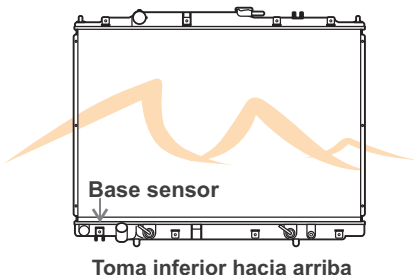
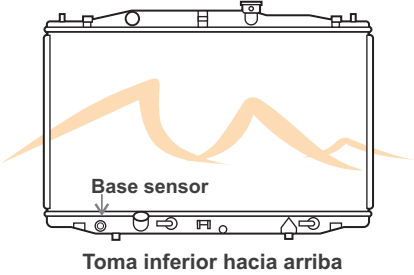
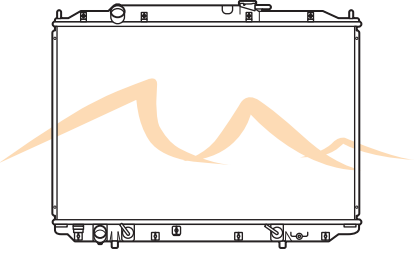
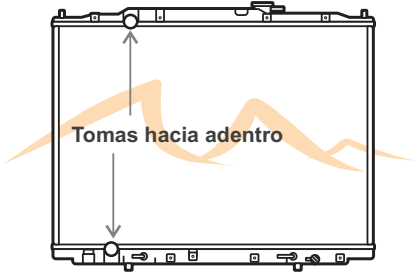
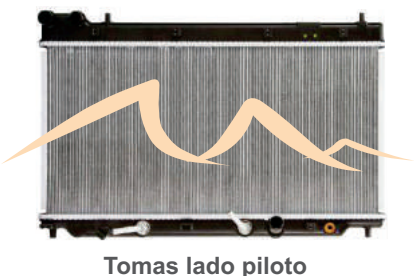
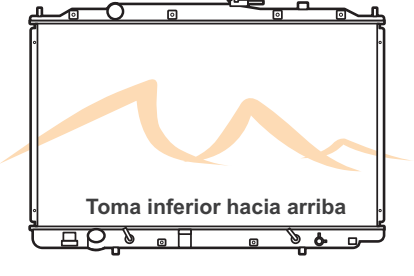
<p>2572 DPI HONDA</p>  <p>CIVIC/HYBRID 03-05 Electric/Gas L4 1.3</p> <p>PANAL: 13 3/4" X 25 7/8" X 5/8" (16 mm) CS: 1 5/16" X 26 11/16" ENTRADA: 1 1/8" CI: 1 9/16" X 26 11/16" SALIDA: 1 1/8" EDA: 14 3/4" Concéntrico EDAM: NO</p> <p>037</p>	<p>2574 DPI HONDA</p>  <p>M/T CIVIC 02-05 L4 2.0</p> <p>PANAL: 13 3/4" X 25 7/8" X 1" (26 mm) CS: 1 7/8" X 26 11/16" ENTRADA: 1 1/4" CI: 1 7/8" X 26 11/16" SALIDA: 1 1/4" EDA: NO EDAM: NO</p> <p>038</p>	<p>2599 DPI HONDA</p>  <p>ACCORD 4 CIL. 03-04 L4 2.4</p> <p>PANAL: 15 3/4" X 27 3/8" X 5/8" (16 mm) CS: 1 5/16" X 28 3/8" ENTRADA: 1 1/4" CI: 1 5/16" X 28 3/8" SALIDA: 1 1/4" EDA: 12 13/16" EDAM: NO</p> <p>039</p>
<p>2740 DPI HONDA / ACURA</p>  <p>MDX/PILOT 03-06/2005 V6 3.5</p> <p>PANAL: 19 11/16" X 19" X 1 5/8" CS: 1 7/8" X 31 1/4" ENTRADA: 1 1/4" CI: 1 7/8" X 31 1/4" SALIDA: 1 1/4" EDA: 14 3/4" EDAM: NO CONDENSADOR: AC3182</p> <p>040</p>	<p>2797 DPI HONDA</p>  <p>ACCORD AUT 05-07 L4 2.4</p> <p>PANAL: 15 3/4" X 27 3/8" X 5/8" (16 mm) CS: 1 15/16" X 28 3/8" ENTRADA: 1 3/8" CI: 1 15/16" X 28 3/8" SALIDA: 1 3/8" EDA: 12 3/4" Concéntrico EDAM: NO</p> <p>041</p>	<p>2806 DPI HONDA</p>  <p>ODYSSEY 05-10 V6 3.5</p> <p>PANAL: 17 11/16" X 29 15/16" X 1" (26 mm) CS: 1 7/8" X 31 1/4" ENTRADA: 1 1/4" CI: 1 7/8" X 31 1/4" SALIDA: 1 1/4" EDA: SI EDAM: NO CONDENSADOR: AC3246</p> <p>042</p>
<p>2830 DPI HONDA</p>  <p>RIDGELINE 06-08 V6 3.5</p> <p>PANAL: 21 11/16" X 30 3/16" X 7/8" (22 mm) CS: 1 7/8" X 31 5/16" ENTRADA: 1 3/8" CI: 1 7/8" X 31 5/16" SALIDA: 1 3/8" EDA: SI 5 PLACAS</p> <p>043</p>	<p>2955 DPI HONDA</p>  <p>FIT 07-08 L4 1.5</p> <p>PANAL: 12 13/16" X 25 3/8" X 11/16" CS: 1 7/16" X 26 13/16" ENTRADA: 1 1/8" CI: 1 11/16" X 26 3/4" SALIDA: 1 1/8" EDA: SI EDAM: NO</p> <p>044</p>	<p>2956 DPI HONDA</p>  <p>PILOT 06-08 V6 3.5</p> <p>PANAL: 19 2/3" X 30 1/4" X 1" (26 mm) CS: 1 9/16" X 30 7/8" ENTRADA: 1 1/4" CI: 1 9/16" X 30 7/8" SALIDA: 1 1/4" EDA: SI (5 PLACAS)</p> <p>CONDENSADOR: AC3182</p> <p>045</p>

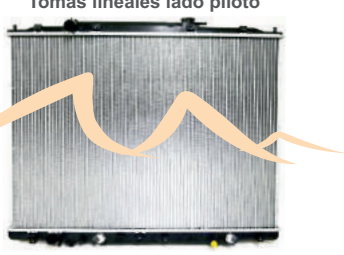
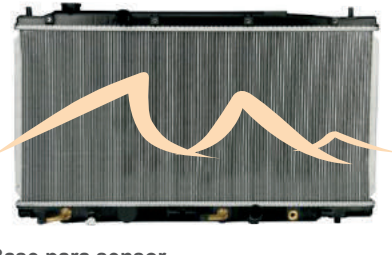
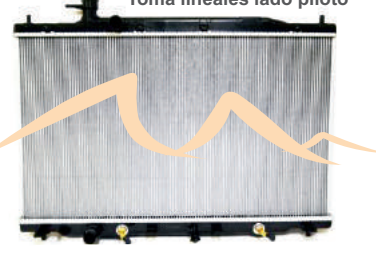
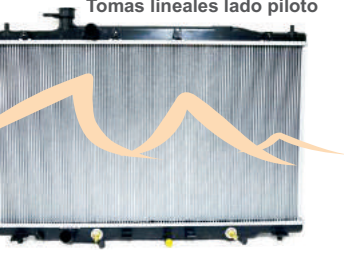
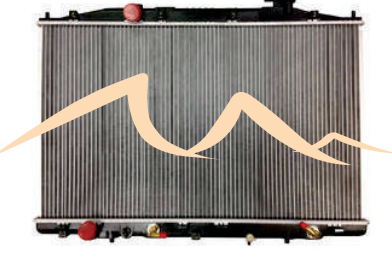
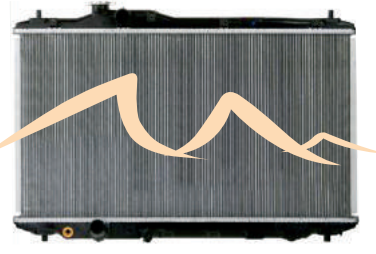
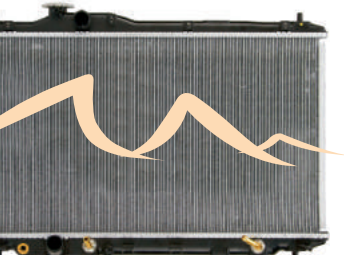
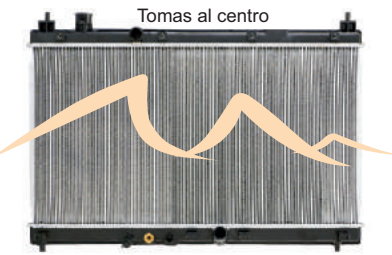
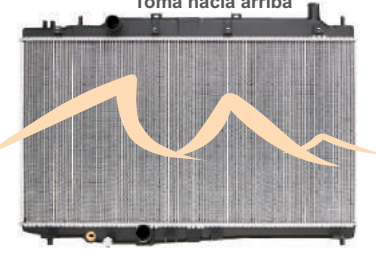
<p>13065 DPI HONDA</p> <p>Tomas lineales lado piloto</p>  <p>Base para sensor</p> <p>PILOT/RIDGELINE 09-14 V6 3.5</p> <p>PANAL: 21 5/8" X 30 1/8" X 1" CS: 2" X 31 1/4" CI: 2" X 31 1/4" EDA: SI 5 Placas EDAM: NO</p> <p>ENTRADA: 1 1/4" SALIDA: 1 1/4"</p> <p>046</p>	<p>13068 DPI HONDA</p>  <p>Base para sensor</p> <p>FIT 09-13 L4 1.5</p> <p>PANAL: 13 3/4" X 28 7/16" X 5/8" CS: 1 9/16" X 29 1/4" CI: 1 9/16" X 29 1/4" EDA: SI Concentrico EDAM: NO</p> <p>ENTRADA: 1 1/8" SALIDA: 1 1/8"</p> <p>047</p>	<p>13155 DPI HONDA</p> <p>Toma lineales lado piloto</p>  <p>Toma inferior de candado</p> <p>CR-V 10-11 L4 2.4</p> <p>PANAL: 16 3/4" X 28 11/16" X 1 1/6" CS: 1 7/16" X 30 1/16" CI: 2" X 30 1/16" EDA: NO EDAM: NO CONDENSADOR: AC3599</p> <p>ENTRADA: 1 5/16" SALIDA: 1 1/4"</p> <p>048</p>
<p>13161 DPI HONDA</p> <p>Tomas lineales lado piloto</p>  <p>Toma inferior de abrazadera</p> <p>CR-V 10-11 L4 2.4</p> <p>PANAL: 16 3/4" X 28 11/16" X 1 1/16" CS: 1 7/16" X 30 1/16" CI: 2" X 30 1/16" EDA: SI Concentrico EDAM: NO CONDENSADOR: AC3599</p> <p>ENTRADA: 1 5/16" SALIDA: 1 1/4"</p> <p>049</p>	<p>13208 DPI HONDA</p>  <p>Tomas mismo lado piloto</p> <p>ODYSSEY 11-15 V6 3.5</p> <p>PANAL: 17 3/4" X 30 1/8" X 5/8" (16) CS: 1 1/4" X 31 1/8" CI: 1 7/8" X 31 1/8" EDA: SI 14 3/4"</p> <p>ENTRADA: 1 5/16" SALIDA: 1 5/16"</p> <p>050</p>	<p>13221 DPI HONDA/ACURA</p>  <p>Toma de abrazadera</p> <p>CIVIC 2014 /ILX 13-14 L4 1.8/2.0/2.4</p> <p>PANAL: 14 3/4" x 26 3/8" x 5/8" CS: 1 7/16" X 27 13/16" CI: 2" X 27 13/16" EDA: NO EDAM: NO CONDENSADOR: AC3976</p> <p>ENTRADA: 1 1/4" SALIDA: 1 5/16"</p> <p>051</p>
<p>13257 DPI HONDA/ACURA</p>  <p>CIVIC/ILX 12-15 L4 1.5/1.8</p> <p>PANAL: 14 3/4" X 26 7/16" X 11/16" CAB. SUP.: 1 7/16" X 27 7/16" CAB. INF.: 1 7/16" X 27 7/16" EDA: SI CONCENTRICO</p> <p>TOMAS: ENTRADA: 1 1/4" SALIDA: 1 1/4"</p> <p>CONDENSADOR: AC3976</p> <p>052</p>	<p>13451 DPI HONDA</p> <p>Tomas al centro</p>  <p>Base sensor</p> <p>FIT 15-17 L4 1.5</p> <p>PANAL: 14 3/4" X 27 1/8" X 5/8" CS: 1 3/8" X 27 13/16" CI: 1 3/8" X 27 13/16" EDA: NO</p> <p>ENTRADA: 1 1/8" SALIDA: 1 1/8"</p> <p>053</p>	<p>13539 DPI HONDA</p> <p>Toma hacia arriba</p>  <p>Base sensor</p> <p>HR-V 16-17 L4 1.8</p> <p>PANAL: 14 3/4" X 26 5/16" X 5/8" CS: 1 5/16" X 27 3/8" CI: 1 5/16" X 27 3/8" EDA: NO EDAM: NO</p> <p>ENTRADA: 1 1/4" SALIDA: 1 1/4"</p> <p>054</p>

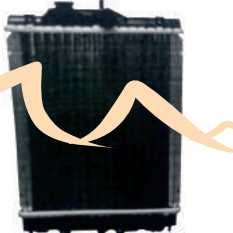
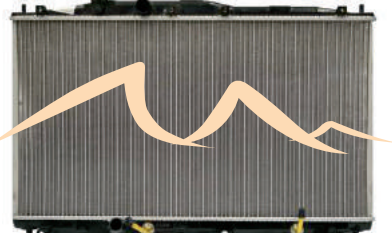
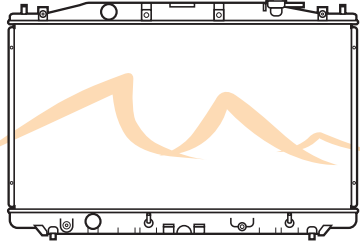
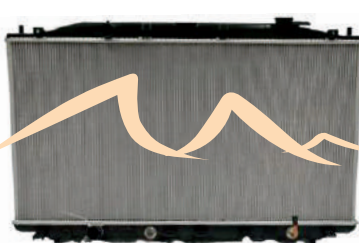
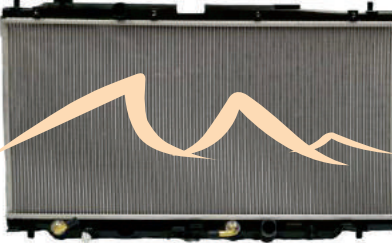
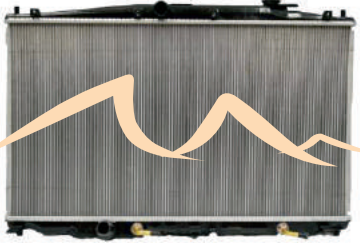
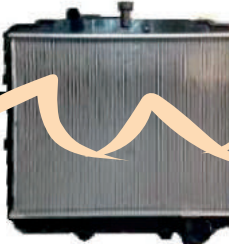
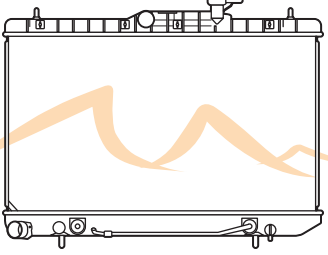
<p>M2274-26C ACURA/HONDA</p> <p>Toma al centro</p>  <p>Tubo mecánico</p> <p>CIVIC 92-00 / EL 97-00</p> <p>DPI 1290 / 6206 PHAR L4 1.5/1.6</p> <p>PANAL: 13 3/4" X 13 3/8" X 1" CAB. SUP.: 1 7/8" X 14 9/16" CAB. INF.: 1 7/8" X 14 9/16" ENF. TRANS.: SI ENF. MOTOR: NO</p> <p>TOMAS: ENTRADA: 1 1/8" SALIDA: 1 1/8"</p> <p>055</p>	<p>M2274-26N ACURA/HONDA</p> <p>Toma al centro</p>  <p>Tubo mecánico</p> <p>CIVIC 92-00 / EL 97-00</p> <p>DPI 1290 / 6206 PHAR L4 1.5/1.6</p> <p>PANAL: 13 3/4" X 13 3/8" X 1" CAB. SUP.: 1 7/8" X 14 9/16" CAB. INF.: 1 7/8" X 14 9/16" ENF. TRANS.: NO ENF. MOTOR: NO</p> <p>TOMAS: ENTRADA: 1 1/8" SALIDA: 1 1/8"</p> <p>056</p>	<p>LHRP176 HONDA</p>  <p>ODYSSEY 05-06</p> <p>V6 3.5 A.T.</p> <p>PANAL: 16 3/4" X 30 1/4" X 5/8" (16mm) CS: 1 3/8" X 31 3/8" CI: 1 13/16" X 31 3/8" EDA: SI</p> <p>ENTRADA: 1 1/4" SALIDA: 1 1/4"</p> <p>057</p>
<p>LHRP349-1R HONDA/ACURA</p>  <p>ROX 2013/ACCORD 08-12</p> <p>V6 3.5</p> <p>DPI 2989</p> <p>PANAL: 15 3/4" X 30 11/32" X 5/8" (16 mm) CS: 31 9/32" X 1 9/32" CI: 31 9/32" X 1 9/32" EDA: SI EDAM: CONDENSADOR: AC3669</p> <p>ENTRADA: 1 1/4" SALIDA: 1 1/4"</p> <p>058</p>	<p>LHRP555 HONDA</p>  <p>ACCORD 08-14/CROSSTOUR 12-14</p> <p>L4 2.4</p> <p>DPI 2990</p> <p>PANAL: 15 3/162 X 30 1/8" X 5/8" CS: 1 9/32" X 31 5/16" CI: 1 7/8" X 31 5/16" EDA: SI</p> <p>ENTRADA: 1 1/4" SALIDA: 1 1/4"</p> <p>CONDENSADOR: AC3669</p> <p>059</p>	<p>LHRP556 HONDA</p>  <p>FIT 09-13</p> <p>L4 1.5</p> <p>DPI 13068</p> <p>PANAL: 13 3/4" X 28 3/16" X 5/8" CS: 1 5/16" X 29 1/4" CI: 1 9/16" X 29 1/4"</p> <p>ENTRADA: 1 1/8" SALIDA: 1 1/8"</p> <p>060</p>
<p>LHRP557 HONDA</p>  <p>ODYSSEY 10-13</p> <p>L4 2.4</p> <p>PANAL: 16 47/64" X 29 17/32" X 1" CS: 1 15/16" X 30 15/32" CI: 1 15/16" X 30 15/32" EDA: SI</p> <p>ENTRADA: 1 1/4" SALIDA: 1 1/4"</p> <p>061</p>	<p>A034-28N HYUNDAI/DODGE</p> <p>Gollete al centro</p>  <p>Toma Escuadra</p> <p>H100 STD 99-07</p> <p>L4 2.5/2.6</p> <p>8178 PHAR</p> <p>PANAL: 15 3/4" X 22 7/16" X 1 1/8" CAB. SUP.: 23 5/16" X 2 1/8" CAB. INF.: 23 5/16" X 2 1/8" ENF. TRANS.: NO ENF. MOTOR: NO</p> <p>TOMAS: ENTRADA: 1 5/16" SALIDA: 1 5/16"</p> <p>02/14</p> <p>062</p>	<p>A2600-13C HYUNDAI</p>  <p>Toma inferior hacia afuera</p> <p>ATTITUD/ACCENT/VERNA 00-06</p> <p>L4 1.5/1.6</p> <p>PANAL: 13 3/16" X 25 5/16" X 5/8" (16 mm) CS: 1 3/8" X 26 1/4" CI: 1 3/4" X 26 1/4" EDA: SI EDAM: NO</p> <p>ENTRADA: 1 5/16" SALIDA: 1 5/16"</p> <p>063</p>

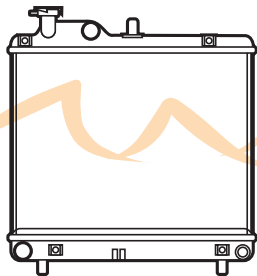
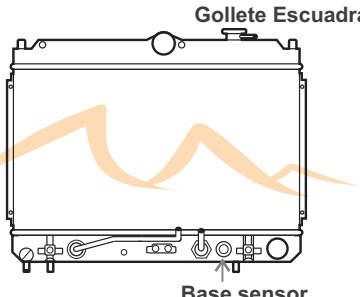
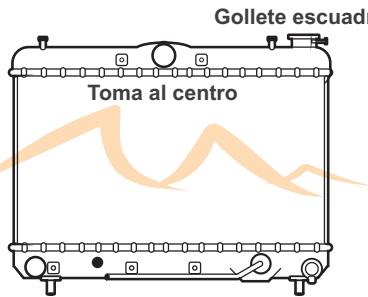
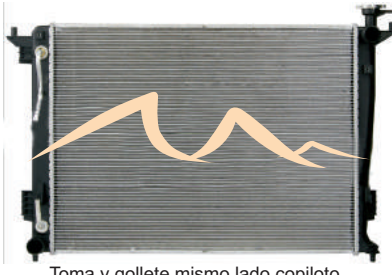
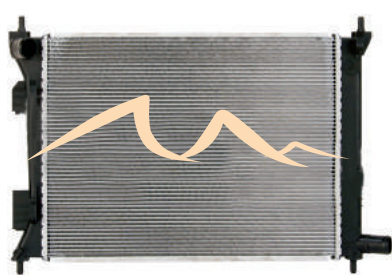
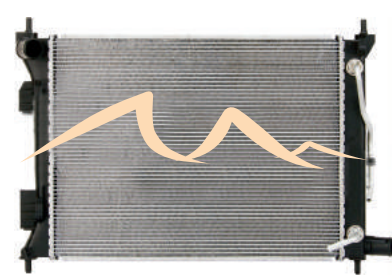
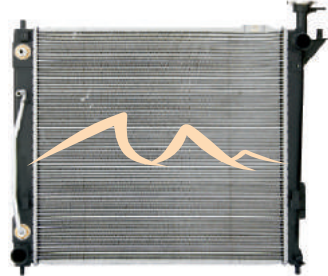
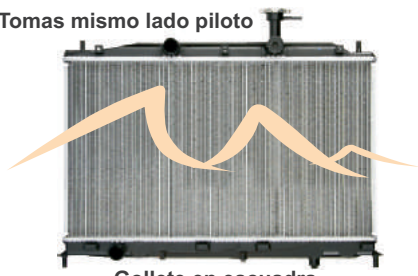
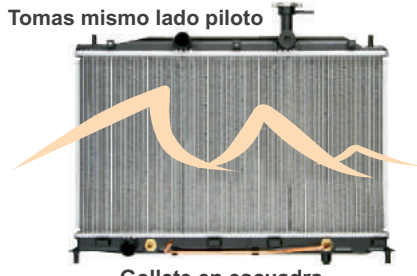
<p>A6031-28N HYUNDAI/CHRYSLER/DODGE</p>  <p>6031 PHAR L4 1.0i</p> <p>PANAL: 14" X 15 17/32" X 1 1/8" CS: 2" X 15 7/8" CI: 2" X 15 7/8"</p> <p>ENTRADA: 1 1/8" SALIDA: 1 1/8"</p> <p>ENFRIADOR: NO</p> <p>064</p>	<p>1823 DPI HYUNDAI</p>  <p>Gollete Escuadra Base sensor</p> <p>SONATA 95-98 L4 2.0 V6 3.0</p> <p>PANAL: 15 3/4" X 26 3/4" X 1 1/4" (32 mm) CS: 1 3/4" X 27 1/4" CI: 1 3/4" X 27 1/4"</p> <p>ENTRADA: 1 3/8" SALIDA: 1 3/8"</p> <p>EDA: SI EDAM: NO</p> <p>065</p>	<p>1897 DPI HYUNDAI</p>  <p>Gollete escuadra Toma al centro</p> <p>ELANTRA/TIBURON 96-01 L4 1.8/2.0</p> <p>PANAL: 14 3/4" X 26 1/4" X 5/8" (16 mm) CS: 1 3/8" X 27 1/4" CI: 1 5/8" X 27 1/4"</p> <p>ENTRADA: 1 1/4" SALIDA: 1 1/4"</p> <p>EDA: SI EDAM: NO NOTAS: Disponible en A/T & M/T</p> <p>066</p>
<p>13150 DPI HYUNDAI/KIA</p>  <p>Toma y gollete mismo lado copiloto</p> <p>TUCSON/SPORTAGE 10-15 L4 2.0/2.4</p> <p>PANAL: 25 1/4" X 18 13/16" X 5/8" (16) CS: 1 13/16" X 19 5/16" CI: 1 13/16" X 19 5/16"</p> <p>ENTRADA: 1 7/16" SALIDA: 1 7/16"</p> <p>EDA: SI 14 1/4"</p> <p>067</p>	<p>13252 DPI DODGE/HYUNDAI</p>  <p>ATTITUD/ACCENT-VELOSTER/KIA RIO 12-16 L3 1.2 / L4 1.4/1.6</p> <p>PANAL: 19 11/16" X 14 1/2" X 5/8" CAB. SUP.: 1 7/16" X 15 7/8" CAB. INF.: 1 7/16" X 15 7/8"</p> <p>TOMAS: ENTRADA: 1 3/8" SALIDA: 1 5/16"</p> <p>Enfriador: NO</p> <p>068</p>	<p>13253 DPI DODGE/HYUNDAI</p>  <p>ATTITUD/ACCENT/KIA RIO 12-16 L3 1.2 / L4 1.4/1.6</p> <p>PANAL: 19 11/16" X 14 1/2" X 5/8" CAB. SUP.: 1 15/16" X 15 7/16" CAB. INF.: 1 15/16" X 15 7/16"</p> <p>TOMAS: ENTRADA: 1 3/8" SALIDA: 1 15/16"</p> <p>Enfriador: NO</p> <p>069</p>
<p>13373 DPI HYUNDAI</p>  <p>Toma junto a gollete</p> <p>SANTA FE 13-17 L4 2.0</p> <p>PANAL: 20 5/64" X 18 13/16" X 7/8" CAB. SUP.: 1 27/32" X 19 5/16" CAB. INF.: 1 27/32" X 19 5/16"</p> <p>TOMAS: ENTRADA: 1 3/8" SALIDA: 1 3/8"</p> <p>Enfriador: SI</p> <p>070</p>	<p>2896 DODGE/HYUNDAI</p>  <p>Tomas mismo lado piloto Gollete en escuadra</p> <p>ATTITUDE/VERNA/ACCENT 06-10 L4 1.5/1.6</p> <p>PANAL: 14 9/16" X 25 3/8" X 5/8" (16mm) CAB. SUP.: 1 13/16" X 25 7/8" CAB. INF.: 1 13/16" X 25 7/8"</p> <p>TOMAS: ENTRADA: 1 3/8" SALIDA: 1 3/8"</p> <p>ENF. TRANS.: SI ENF. MOTOR: NO</p> <p>071</p>	<p>2896-2 DODGE/HYUNDAI</p>  <p>Tomas mismo lado piloto Gollete en escuadra</p> <p>ATTITUDE/VERNA/ACCENT 06-10 L4 1.5/1.6</p> <p>PANAL: 14 9/16" X 25 3/8" X 5/8" (16mm) CAB. SUP.: 1 13/16" X 25 7/8" CAB. INF.: 1 13/16" X 25 7/8"</p> <p>TOMAS: ENTRADA: 1 3/8" SALIDA: 1 3/8"</p> <p>ENF. TRANS.: NO ENF. MOTOR: NO</p> <p>072</p>

LHRP185

HYUNDAI

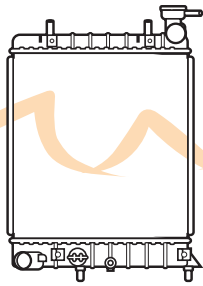

ACCENT/VERNA 1999

L4 1.6i

PANAL: 13 3/16" X 12 1/2" X 5/8" (16 mm)
 CS: 12 25/32" X 1 1/2" ENTRADA: 1 5/16"
 CI: 12 25/32" X 1 1/2" SALIDA: 1 5/16"
 EDA: NO
 EDAM:

073

LHRP532

HYUNDAI/DODGE

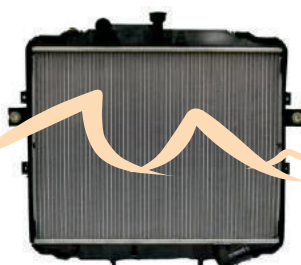

Motor Diesel

H100 06-11

L4 2.5

PANAL: 17 33/64" X 22 3/4" X 1 13/32"
 CS: 2 7/16" X 23 1/8" ENTRADA: 1 3/8"
 CI: 2 7/16" X 23 1/8" SALIDA: 1 3/8"
 EDA: NO

074

LHRP589-1

DODGE/HYUNDAI

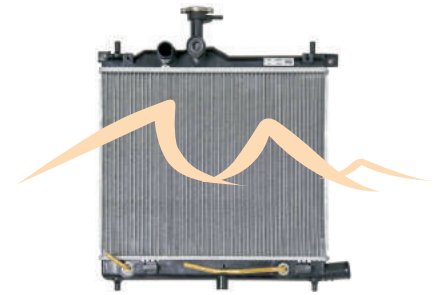

GRAND I10 15-16

1.0/1.6

PANAL: 13 3/4" X 17 1/4" X 1"
 CAB. SUP.: 1 13/16" X 17 25/32" TOMAS:
 CAB. INF.: 1 13/16" X 17 25/32" ENTRADA: 1 1/8"
 Enfrizador: SI SALIDA: 1 1/8"

075

LHRP665-2

HYUNDAI

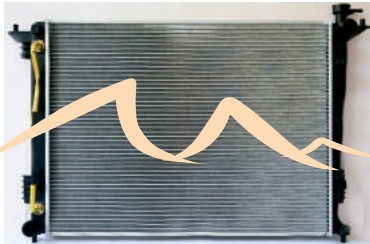

Tomas y gollete mismo lado copiloto

Lx35 09-15

L4 2.0

PANAL: 25" X 18 7/8" X 1" (26)
 CS: 1 7/8" X 19 1/4" ENTRADA: 1 7/16"
 CI: 1 7/8" X 19 1/4" SALIDA: 1 7/16"
 EDA: SI 14 1/2"

076

My
PHAR

www.phar.com.mx

**PRUEBA NUESTRA
VERSION IMPRESA
EN LINEA**

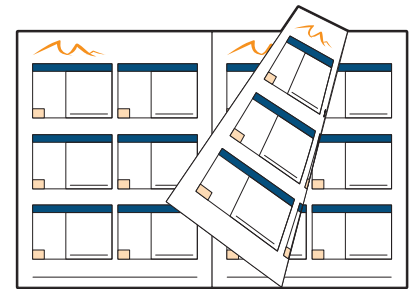

www.phar.com.mx

**Escanea nuestro código
QR con tu smartphone**

**Descarga la aplicación
desde tu Smartphone
en: www.2dscan.com**

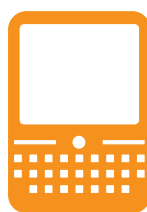



Radiadores

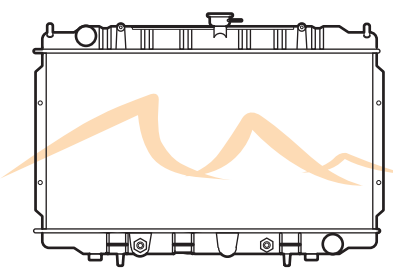
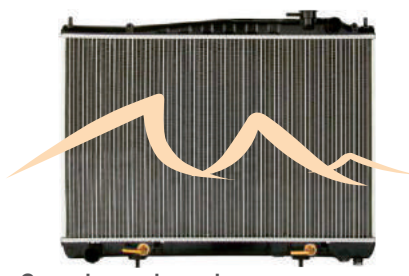
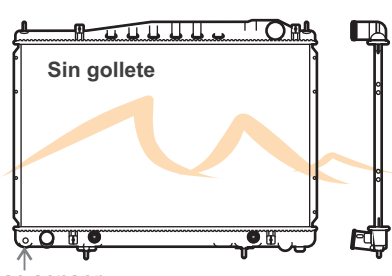
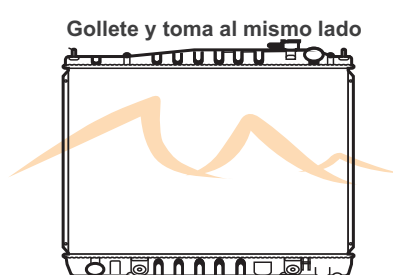
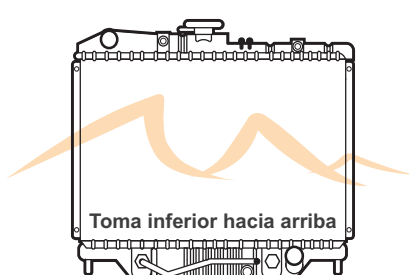
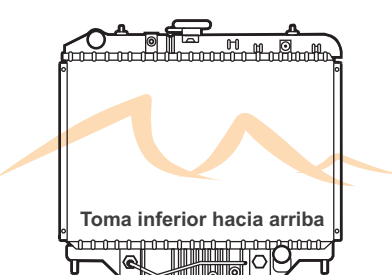
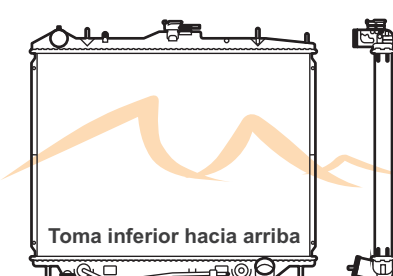
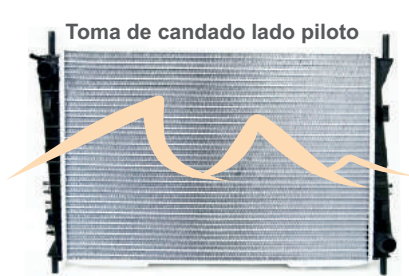
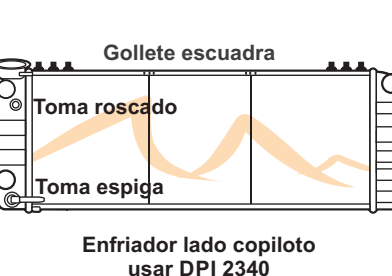

PHAR

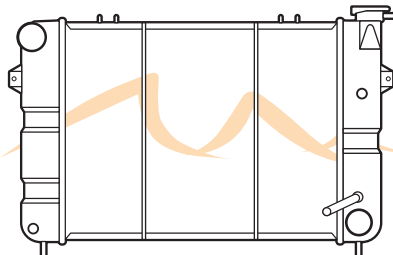
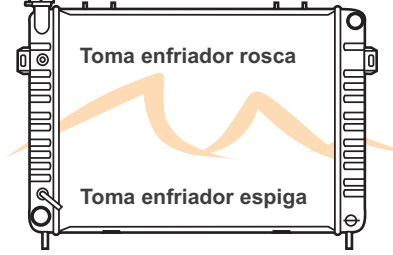
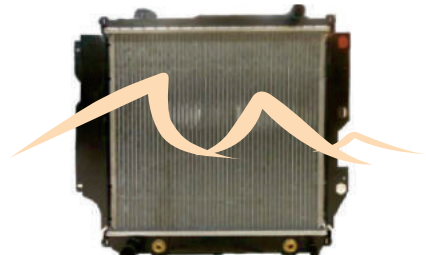
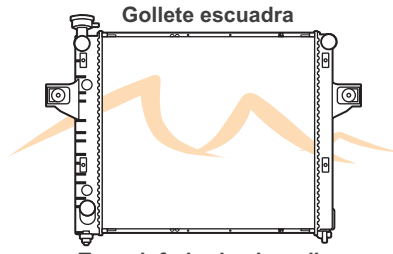
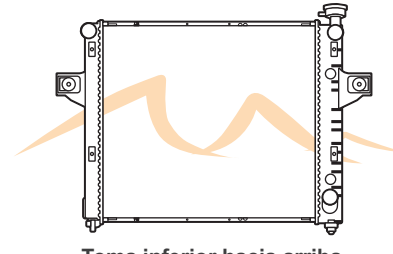
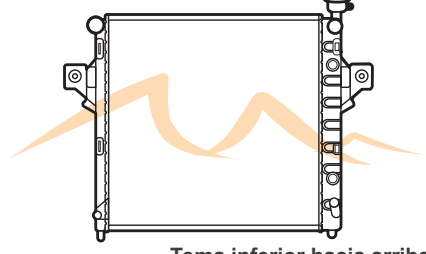
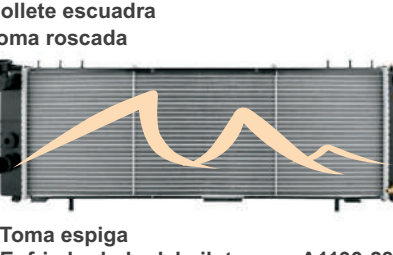
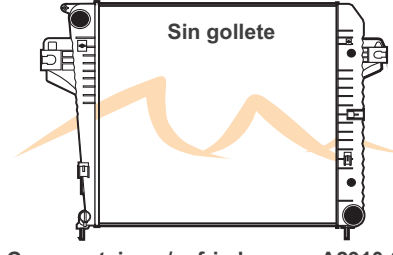
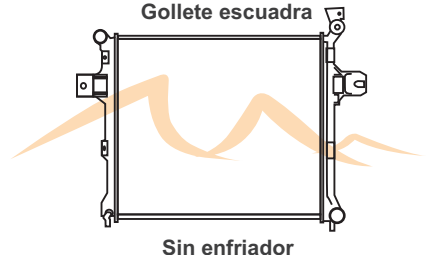
- **INFINITI**
- **ISUZU**
- **JAGUAR**
- **JEEP**

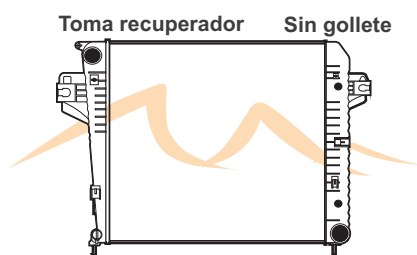
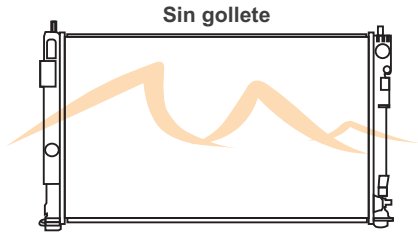
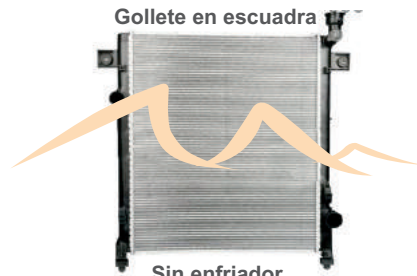
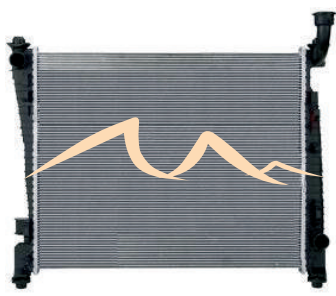
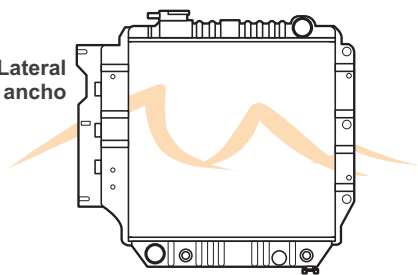
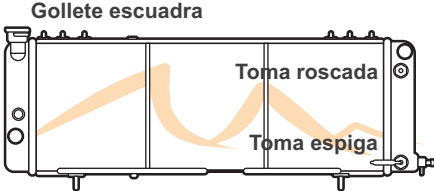
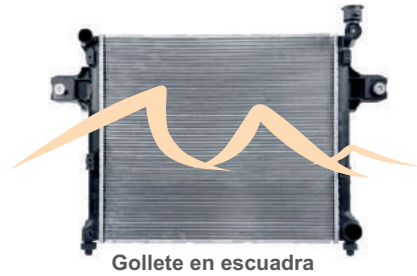
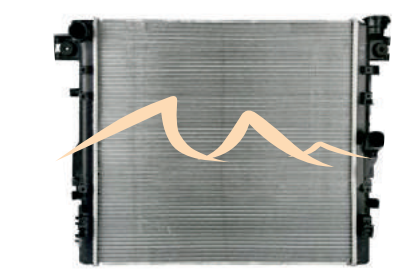
<p>1752 DPI INFINITI / NISSAN</p>  <p>MAXIMA/i130 95-00</p>	<p>2054 DPI INFINITI / NISSAN</p>  <p>Q45 96-01</p>	<p>2426 DPI INFINITI</p>  <p>Q45/M45 02-06</p>
<p>6025 PHAR V6 3.0</p> <p>PANAL: 15 3/4" X 27 1/8" X 1" (26 mm) CS: 2" X 28 1/8" ENTRADA: 1 3/8" CI: 2" X 28 1/8" SALIDA: 1 3/8" EDA: 11 7/8" EDAM: NO NOTAS: Puede usar ST: 2181</p> <p style="text-align: right;">001</p>	<p>6025 PHAR V8 4.1/4.5</p> <p>PANAL: 17 11/16" X 27 13/64" X 1 5/16" CS: 1 7/8" X 28 1/16" CI: 2 1/4" X 28 1/16" EDA: SI Concéntrico EDAM: NO</p> <p style="text-align: right;">002</p>	<p>6025 PHAR V8 4.5</p> <p>PANAL: 17 11/16" X 27" X 5/8" (16 mm) CS: 1 7/8" X 28 1/16" CI: 1 7/8" X 28 1/16" EDA: 14 3/4" EDAM: NO</p> <p style="text-align: right;">003</p>
<p>2459 DPI INFINITI / NISSAN</p>  <p>PATHFINDER 01-04/QX4 01-03</p>	<p>1571 DPI ISUZU / HONDA</p>  <p>PASSAPORT 94-97/RODEO 93-01</p>	<p>2195 DPI ISUZU / HONDA</p>  <p>PASSAPORT/RODEO 98-04</p>
<p>6104 PHAR V6 3.5</p> <p>PANAL: 19 3/4" X 27 3/16" X 1" (26 mm) CS: 1 15/16" X 28 1/8" ENTRADA: 1 3/8" CI: 2 7/16" X 28 1/8" SALIDA: 1 3/8" EDA: 14 3/4" Concéntrico EDAM: NO</p> <p style="text-align: right;">004</p>	<p>6104 PHAR V6 3.2/3.5</p> <p>PANAL: 16 3/4" X 24 1/4" X 5/8" (16 mm) CS: 2" X 25" ENTRADA: 1 1/2" CI: 2" X 25" SALIDA: 1 1/2" EDA: SI EDAM: NO</p> <p style="text-align: right;">005</p>	<p>6104 PHAR V6 3.2/3.5</p> <p>PANAL: 16 3/4" X 24 1/4" X 1 1/4" (32 mm) CS: 2 1/16" X 25 1/16" ENTRADA: 1 1/2" CI: 2 1/16" X 25 1/16" SALIDA: 1 1/2" EDA: 13 3/4" EDAM: NO</p> <p style="text-align: right;">006</p>
<p>2445 DPI ISUZU</p>  <p>AXIOM 02-04</p>	<p>2622 DPI JAGUAR</p>  <p>X-TYPE 02-08</p>	<p>A1193-28C JEEP</p>  <p>CHEROKEE 91-01</p>
<p>6104 PHAR V6 3.5</p> <p>PANAL: 16 3/4" X 24" X 1 7/16" (36 mm) CS: 2 1/16" X 25 1/16" ENTRADA: 1 1/2" CI: 2 1/16" X 25 1/16" SALIDA: 1 1/2" EDA: 13 3/4" EDAM: NO</p> <p style="text-align: right;">007</p>	<p>6104 PHAR V6 2.5/3.0</p> <p>PANAL: 24 7/16" X 17 1/16" X 1 1/16" CS: 2 1/8" X 17 1/2" CI: 2 1/8" X 17 1/2" EDA: NO EDAM: NO</p> <p style="text-align: right;">008</p>	<p>DPI 1193 L4 2.5 L6 4.0</p> <p>PANAL: 30 13/16" X 10" X 1 1/8" CS: 2 3/4" X 10 3/4" CI: 2 3/4" X 10 3/4" EDA: SI</p> <p style="text-align: right;">009</p>

<p>A1394-28C JEEP</p>  <p>GRAND CHEROKEE 93-97</p> <p>2219 PHAR V8 5.2</p> <p>PANAL: 22 1/8" X 19 7/8" X 1 1/8" CS: 2 1/4" X 20 1/4" ENTRADA: 1 1/2" CI: 2 1/4" X 20 1/4" SALIDA: 1 3/4" EDA: 12" EDAM: NO</p> <p style="text-align: right;">010</p>	<p>A1396-28C JEEP</p>  <p>Toma enfriador rosca Toma enfriador espiga</p> <p>GRAND CHEROKEE 93-97</p> <p>DPI 1396 / 2222 PHAR L6 4.0</p> <p>PANAL: 22 1/4" X 19 7/8" X 1 1/8" CS: 2 1/4" X 20 1/4" ENTRADA: 1 1/4" CI: 2 1/4" X 20 1/4" SALIDA: 1 1/2"</p> <p>ENFRIADOR: SI</p> <p style="text-align: right;">011</p>	<p>A2101-28C JEEP</p>  <p>WRANGLER / TJ 97-06</p> <p>DPI 2760/2102 L4 2.4/2.5 L6 4.0</p> <p>PANAL: 18 1/8" X 19 1/4" X 1 1/8" CAB. SUP.: 20 1/4" X 2 9/16" CAB. INF.: 20 1/4" X 2 9/16" ENF. TRANS.: SI ENF. MOTOR: NO</p> <p>TOMAS: ENTRADA: 1 1/2" SALIDA: 1 1/4"</p> <p style="text-align: right;">012</p>
<p>A2262-28C JEEP</p>  <p>Gollete escuadra Toma inferior hacia arriba</p> <p>GRAND CHEROKEE 99-04</p> <p>DPI 2262 / 7006 PHAR L6 4.0</p> <p>PANAL: 23 1/2" X 21 7/8" X 1 1/8" CS: 2 3/8" X 22 9/16" ENTRADA: 1 1/2" CI: 2 3/8" X 22 9/16" SALIDA: 1 1/2"</p> <p>ENFRIADOR: SI 1048136</p> <p style="text-align: right;">013</p>	<p>A2263-28P6 JEEP</p>  <p>Gollete escuadra Toma inferior hacia arriba</p> <p>GRAND CHEROKEE 99-00</p> <p>DPI 2263 / 7008 PHAR V8 4.7</p> <p>PANAL: 23 1/2" X 21 7/8" X 1 1/8" CS: 2 3/8" X 22 9/16" ENTRADA: 1 1/2" CI: 2 3/8" X 22 9/16" SALIDA: 1 1/2"</p> <p>ENFRIADOR: SI 1048136</p> <p style="text-align: right;">014</p>	<p>A2336-28C JEEP</p>  <p>Gollete escuadra Toma inferior hacia arriba</p> <p>GRAND CHEROKEE 01-04</p> <p>DPI 2336 / 7035 PHAR V8 4.7</p> <p>PANAL: 23 3/16" X 20 5/16" X 1 1/8" CS: 2 3/8" X 21 1/8" ENTRADA: 1 1/2" CI: 2 3/8" X 21 1/8" SALIDA: 1 1/2"</p> <p>ENFRIADOR: SI 6 PLACAS</p> <p style="text-align: right;">015</p>
<p>A2340-28C JEEP</p>  <p>Gollete escuadra Toma roscada Toma espiga Enfriador lado del piloto usar A1193-28C</p> <p>CHEROKEE 91-01 SPORT</p> <p>L6 4.0</p> <p>PANAL: 30 13/16" X 10" X 1 1/8" CAB. SUP.: 11 5/16" X 2 7/8" CAB. INF.: 11 5/16" X 2 7/8" ENF. TRANS.: SI ENF. MOTOR: NO</p> <p>TOMAS: ENTRADA: 1 1/2" SALIDA: 1 5/16"</p> <p style="text-align: right;">016</p>	<p>A2481-28P5 JEEP</p>  <p>Toma de recuperador Sin gollete Con montajes p/enfriador usar A2910-28C</p> <p>LIBERTY 02-06</p> <p>DPI 2481 / 7020 PHAR V6 3.7</p> <p>PANAL: 20" X 20" X 1 1/8" CS: 2 9/16" X 21" CI: 2 9/16" X 21"</p> <p>ENFRIADOR: SI 757019 CONDENSADOR: AC3058</p> <p>ENTRADA: 1 1/2" SALIDA: 1 3/4"</p> <p style="text-align: right;">017</p>	<p>A2839-28N JEEP</p>  <p>Gollete escuadra Sin enfriador</p> <p>CHEROKEE 05-10/COMANDER 06-10</p> <p>DPI 2839 V6 3.0/3.7 V8 4.7/6.1</p> <p>PANAL: 23 1/4" X 21 5/8" X 1 1/8" CS: 2 1/2" X 21 3 1/6" CI: 2 1/2" X 21 3/16"</p> <p>ENFRIADOR: NO CONDENSADOR: AC3247</p> <p>ENTRADA: 1 1/2" SALIDA: 1 3/4"</p> <p style="text-align: right;">018</p>

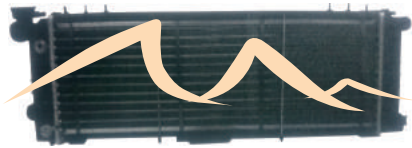
<p>A2910-28P5 JEEP</p>  <p>Toma recuperador Sin gollete</p> <p>Sin montajes p/enfriador usar A2481-28C</p> <p>LIBERTY 02-06</p> <p>DPI 2810 / 2910 PHAR V6 3.7</p> <p>PANAL: 20" X 19 7/8" X 1 1/8" CS: 2 9/16" X 21" CI: 2 9/16" X 21"</p> <p>ENTRADA: 1 1/2" SALIDA: 1 13/16"</p> <p>ENFRIADOR: SI, 757019</p> <p>019</p>	<p>A2951-13N JEEP/CHRYSLER/DODGE</p>  <p>Sin gollete</p> <p>COMPAS 07-13/PATRIOT/AVENGER 07-13/CALIBER</p> <p>DPI 2951 L4 1.8/2.0/2.4 V6 2.7/3.5/3.6</p> <p>PANAL: 27 5/8" X 16 4/5" X 1/2" CS: 1 13/16" X 16 11/16" CI: 1 13/16" X 16 11/16"</p> <p>ENTRADA: 1 3/8" SALIDA: 1 3/8"</p> <p>ENFRIADOR: NO CONDENSADOR: AC3586</p> <p>020</p>	<p>A13071-28N JEEP</p>  <p>Gollete en escuadra</p> <p>Sin enfriador</p> <p>LIBERTY 08-13</p> <p>DPI 2810 / 2910 PHAR V6 3.7</p> <p>PANAL: 19 13/16" X 23 1/8" X 1 1/8" CS: 1 13/16" X 23 15/16" CI: 1 13/16" X 23 15/16"</p> <p>ENTRADA: 1 1/2" SALIDA: 1 3/4"</p> <p>EDA: NO EDAM: NO</p> <p>021</p>
<p>A13200-13N DODGE/JEEP</p>  <p>DURANGO 11-14 / GRAND CHEROKEE 11-15</p> <p>DPI-13200 V6 3.6 / V8 5.7</p> <p>PANAL: 25 1/16" X 20 9/16" X 1/2" CAB. SUP.: 1 5/8" X 21 5/8" CAB. INF.: 1 5/8" X 21 5/8"</p> <p>ENTRADA: 1 1/2" SALIDA: 1 1/2"</p> <p>ENFRIADOR: NO CONDENSADOR: AC3893</p> <p>022</p>	<p>1682 DPI JEEP</p>  <p>Lateral ancho</p> <p>WRANGLER 87-95</p> <p>DPI 1682 / 1111 PHAR L4 2.5 L6 4.0/4.2</p> <p>PANAL: 18 1/2" X 20" X 1 1/4" (32 mm) CS: 2 1/2" X 20 1/2" CI: 2 1/2" X 20 1/2"</p> <p>ENTRADA: 1 1/4" SALIDA: 1 1/4"</p> <p>EDA: SI</p> <p>023</p>	<p>2340 DPI JEEP</p>  <p>Gollete escuadra</p> <p>Toma roscada</p> <p>Toma espiga</p> <p>Enfriador lado del piloto usar A1193-28C</p> <p>CHEROKEE/WAGONER 91-01</p> <p>DPI 2340 L6 4.0</p> <p>PANAL: 31" X 11 1/8" X 1 1/2" CS: 2 3/4" X 10 3/4" CI: 2 3/4" X 10 3/4"</p> <p>ENTRADA: 1 1/4" SALIDA: 1 1/2"</p> <p>EDA: 7 1/2" EDAM: NO</p> <p>024</p>
<p>2840 DPI JEEP</p>  <p>Gollete en escuadra</p> <p>GRAND CHEROKEE 05-10/COMMANDER 06-10</p> <p>V8 5.7</p> <p>PANAL: 23 1/4" X 20 3/8" X 1 1/4" CS: 2 1/2" X 21 1/16" CI: 2 1/2" X 21 1/16"</p> <p>ENTRADA: 1 3/8" SALIDA: 1 13/16"</p> <p>EDA: NO EDAM: NO CONDENSADOR: AC3247</p> <p>025</p>	<p>2957 DPI JEEP</p>  <p>WRANGLER 07-11</p> <p>V6 3.6/3.8</p> <p>PANAL: 22" X 21 1/4" X 1" CS: 1 13/16" X 21 1/8" CI: 1 13/16" X 21 1/8"</p> <p>ENTRADA: 1 1/2" SALIDA: 1 1/2"</p> <p>EDA: NO EDAM: NO</p> <p>026</p>	<p>AT2340-28C JEEP</p>  <p>CHEROKEE 91-01 SPORT</p> <p>L6 4.0</p> <p>PANAL: 30 13/16" X 10" X 1 1/8" CAB. SUP.: 11 5/16" X 2 7/8" CAB. INF.: 11 5/16" X 2 7/8"</p> <p>ENF. TRANS.: SI ENF. MOTOR: NO</p> <p>TOMAS: ENTRADA: 1 1/2" SALIDA: 1 5/16"</p> <p>027</p>

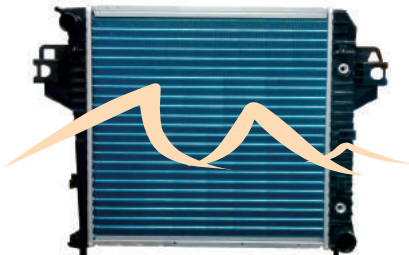
M1193-26C	JEEP	M2340-26C	JEEP	M2481-26P5	JEEP
Aluminio mecánico		Aluminio mecánico		Toma de recuperador	Sin gollete
					
Gollete en escuadra y sensor lado piloto		Gollete en escuadra y base para sensor lado piloto		Con montajes p/enfriador usar M2910-26P5	
CHEROKEE 91-01		CHEROKEE/WAGONER 91-01		LIBERTY 02-06	
L6 2.5/4.0		L6 4.0		V6 3.7	
PANAL: 30 13/16" X 10" X 1" CS: 11 1/4" X 2 3/4" CI: 11 1/4" X 2 3/4" EDA: SI 7 1/2"		PANAL: 30 13/16" X 10" X 1" CS: 11 1/4" X 2 3/4" CI: 11 1/4" X 2 3/4" EDA: SI 7 1/2"		PANAL: 20" X 19 3/4" X 1" CAB. SUP.: 20 13/16" X 2 3/8" CAB. INF.: 20 13/16" X 2 3/8" ENFRIADOR: SI 12" CONDENSADOR: AC3058	
028		029		030	

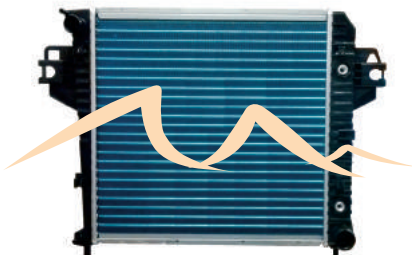
M2910-26P5	JEEP
Toma de recuperador	Sin gollete
	
Sin montajes p/enfriador usar M2481-26P5	
LIBERTY 02-06	
V6 3.7	
PANAL: 20" X 19 3/4" X 1" CAB. SUP.: 20 13/16" X 2 3/8" CAB. INF.: 20 13/16" X 2 3/8" ENFRIADOR: SI 12"	
TOMAS: ENTRADA: 1 1/2" SALIDA: 1 13/16"	
031	



www.phar.com.mx

**PRUEBA NUESTRA
VERSION IMPRESA
EN LINEA**



www.phar.com.mx

NOTAS

NOTAS



Large lined area for notes, with a decorative orange wave graphic at the bottom.

Radiadores

PHAR

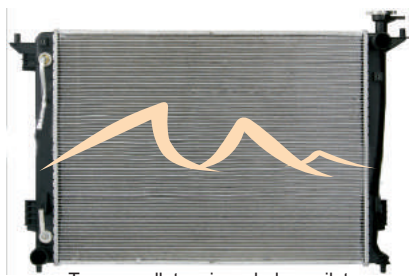
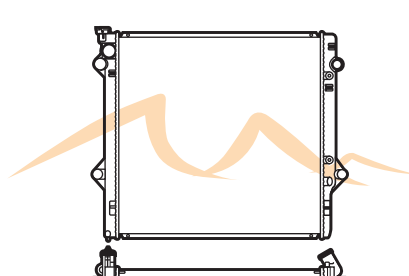
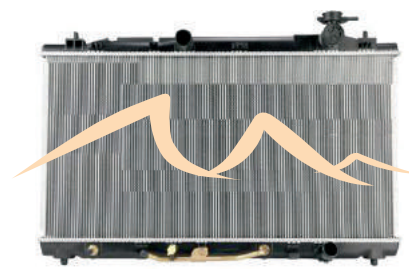
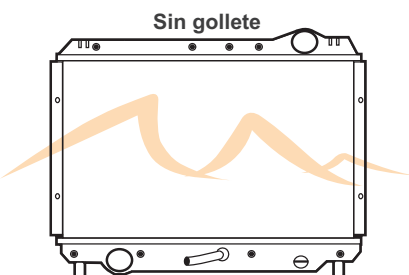
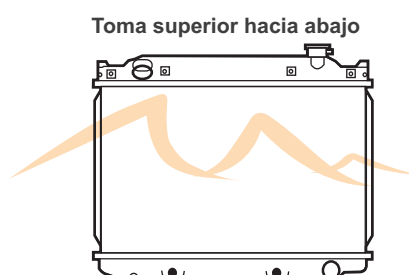
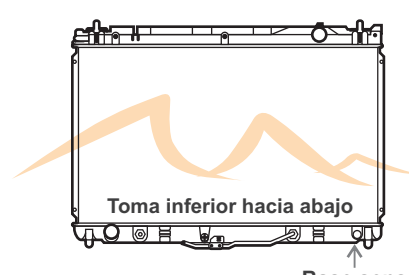
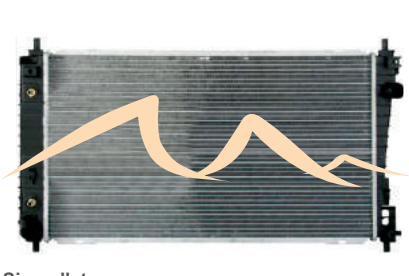
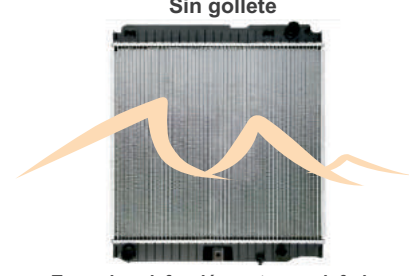
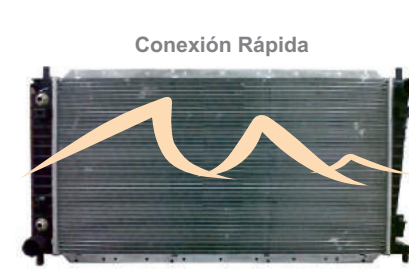
- **KIA**
- **LEXUS**
- **LINCOLN**
- **MACK**

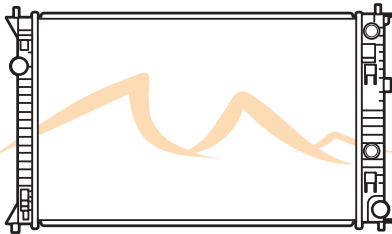
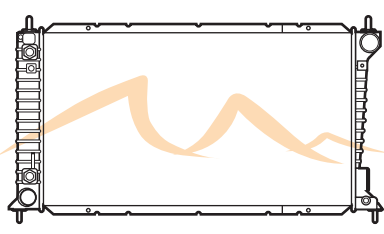
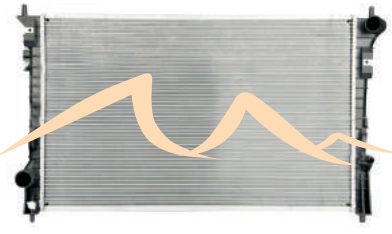
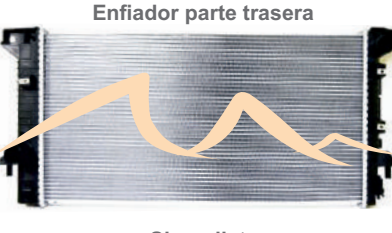
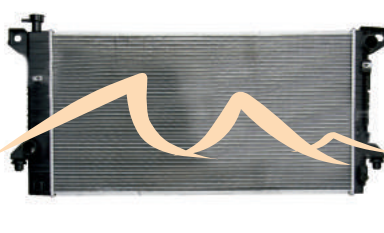
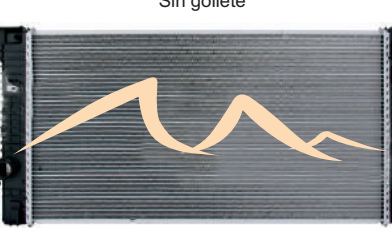
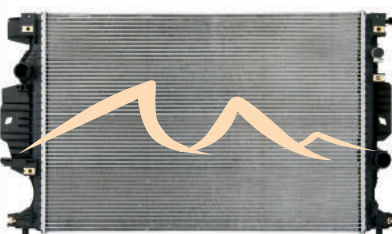
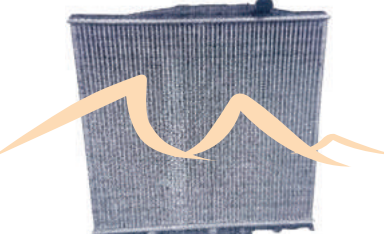
<p>13150 DPI HYUNDAI/KIA</p>  <p>Toma y gollete mismo lado copiloto</p> <p>TUCSON/SPORTAGE 10-15 L4 2.0/2.4</p> <p>PANAL: 25 1/4" X 18 13/16" X 5/8" (16) CS: 1 13/16" X 19 5/16" ENTRADA: 1 7/16" CI: 1 13/16" X 19 5/16" SALIDA: 1 7/16" EDA: SI 14 1/4"</p> <p>001</p>	<p>A2581-28C LEXUS/TOYOTA</p>  <p>4 RUNNER 03-09/GX470 03-09 V8 4.7</p> <p>PANAL: 25 5/8" X 23 1/8" X 1 1/8" CS: 2 1/8" X 24 3/16" ENTRADA: 1 1/2" CI: 2 1/8" X 24 3/16" SALIDA: 1 1/2" EDA: SI</p> <p>002</p>	<p>A13035-13C LEXUS/TOYOTA</p>  <p>CAMRY 07-11/ES350 07-12 L4 2.4/V6 3.5</p> <p>PANAL: 15 3/4" X 28 5/16" X 1/2" CS: 1 7/8" X 31 1/4" ENTRADA: 1 3/8" CI: 1 7/8" X 31 1/4" SALIDA: 1 3/8" EDA: 14 3/4" 752817-M</p> <p>003</p>
<p>1746 DPI LEXUS/TOYOTA</p>  <p>Sin gollete</p> <p>AVALON 94-99/CAMRY/ES300 94-96 V6 3.0</p> <p>PANAL: 16 3/4" X 28 1/4" X 1 1/8" (28 mm) CS: 1 7/8" X 29" ENTRADA: 1 3/8" CI: 1 7/8" X 29" SALIDA: 1 3/8" EDA: 14 3/4" EDAM: NO</p> <p>004</p>	<p>1918 DPI LEXUS/TOYOTA</p>  <p>Toma superior hacia abajo</p> <p>LAND CRUISER 93-97/LX450 96-97 L6 4.5</p> <p>PANAL: 16 3/4" X 27 7/8" X 2" (49 mm) CS: 2 11/16" X 28 5/16" ENTRADA: 1 1/2" CI: 2 11/16" X 28 5/16" SALIDA: 1 9/16" EDA: SI EDAM: NO NOTAS: Puede usar 1917</p> <p>005</p>	<p>2435 DPI LEXUS/TOYOTA</p>  <p>Toma inferior hacia abajo</p> <p>CAMRY 02-06/ES300 02-03 V6 3.0/3.3</p> <p>PANAL: 15 3/4" X 30" X 5/8" (16 mm) CS: 1 7/8" X 29 3/4" ENTRADA: 1 5/16" CI: 1 7/8" X 29 3/4" SALIDA: 1 5/16" EDA: 14 3/4" EDAM: NO</p> <p>Base sensor</p> <p>006</p>
<p>A1729-28C LINCOLN</p>  <p>Sin gollete</p> <p>CONTINENTAL 95-02 V8 4.6</p> <p>PANAL: 29 7/8" X 16 13/16" X 1/8" CS: 1 7/8" X 17 3/16" ENTRADA: 1 1/2" CI: 3 1/16" X 17 3/16" SALIDA: 1 1/2" EDA: NO EDAM: NO</p> <p>007</p>	<p>A2603-28N LINCOLN</p>  <p>Sin gollete</p> <p>Toma de calefacción en tanque inferior</p> <p>AVIATOR 03-05 V8 4.6</p> <p>PANAL: 21 3/4" X 23 5/8" X 1 1/8" CS: 1 15/16" X 23 15/16" ENTRADA: 1 1/2" CI: 1 15/16" X 23 15/16" SALIDA: 1 1/2" ENFRIADOR: NO</p> <p>008</p>	<p>A2719-44P7 LINCOLN/FORD</p>  <p>Conexión Rápida</p> <p>LOBO/F150/F250/F350 03-04/NAVIGATOR/BLACKWOOD 03,05,06 V8 4.6/5.4</p> <p>PANAL: 31 13/16" X 16 13/32" X 1 3/4" CAB. SUP: 17 1/8" X 3" T. ENTRADA: 1 3/4" CAB. INF: 17 1/8" X 3" T. SALIDA: 1 3/4" ENFRIADOR: SI 12" 7 PLACAS</p> <p>CONDENSADOR: AC3092</p> <p>009</p>

<p>A2856-28C LINCOLN/FORD/MERCURY</p>  <p>FUSION 06-09/ MILAN 06-09/ ZEPHYR 06 L4 2.3 V6 3.0</p> <p>PANAL: 25 5/8" X 16 3/4" X 1 1/8" CS: 2 3/16" X 18" CI: 2 3/16" X 18" EDA: SI</p> <p>ENTRADA: 1 1/2" SALIDA: 1 1/2"</p> <p>010</p>	<p>2819 DPI LINCOLN/FORD</p>  <p>V8 4.6/5.4</p> <p>PANAL: 31 7/8" X 16 7/8" X 1 7/16" (36 mm) CS: 3 1/8" X 17 7/8" CI: 2" X 17 7/8" EDA: 12" 7 PLACAS EDAM: NO</p> <p>ENTRADA: 1 1/4" SALIDA: 1 1/4"</p> <p>011</p>	<p>2937 DPI FORD/MERCURY/LINCOLN</p>  <p>EDGE/TAURUS/MKS/MKX/SABLE 07-15 DPI 2937 V6 3.5/3.7</p> <p>PANAL: 28 3/4" X 17 3/4" X 1" CAB. SUP.: 1 13/16" X 18 3/16" CAB. INF.: 1 13/16" X 18 3/16" Enfriador: NO</p> <p>TOMAS: ENTRADA: 1 1/2" SALIDA: 1 1/2"</p> <p>CONDENSADOR: AC3678 012</p> <p>Doble toma lado piloto</p>
<p>13045 DPI LINCOLN/FORD</p>  <p>EXPEDITION/NAVIGATOR 07-09 V8 5.4</p> <p>PANAL: 31 1/2" X 16 1/2" X 1 1/4" CS: 2 5/8" X 17 9/16" CI: 2 5/8" X 17 9/16" EDA: NO EDAM: SI 7 Placas CONDENSADOR: AC3618</p> <p>Enfriador parte trasera</p> <p>Sin gollete</p> <p>013</p>	<p>13099 DPI FORD/LINCOLN</p>  <p>EXPEDITION 09-14/F-SERIES 150, 250 09-10/ LOBO 2010/NAVIGATOR 09-14/MARK LT 2010 V8 4.6/5.4/6.2</p> <p>PANAL: 31 1/2" X 16 1/2" X 1 1/4" CAB. SUP.: 2 9/16" X 17 5/8" CAB. INF.: 2 9/16" X 17 5/8" Enfriador: SI</p> <p>TOMAS: ENTRADA: 1 1/2" SALIDA: 1 9/16"</p> <p>CONDENSADOR: AC3618 014</p>	<p>13226 DPI FORD/LINCOLN</p>  <p>F-150/LOBO/MARK LT 11-14 V6 3.5/3.7 / V8 5.0</p> <p>PANAL: 31 1/2" X 16 7/16" X 1 1/4" (32) CS: 2 9/16" X 17 5/8" CI: 2 9/16" X 17 5/8" EDA: SI PLACAS</p> <p>Enfriador atrás lado piloto</p> <p>Sin gollete</p> <p>CONDENSADOR: AC3618/AC3975 015</p>
<p>13321 DPI FORD/LINCOLN</p>  <p>FUSION/MKZ 13-16 L4 1.5/1.6/2.0/2.5</p> <p>PANAL: 26 7/16" X 18" X 1" (26) CS: 1 5/8" X 18 9/16" CI: 1 5/8" X 18 9/16" EDA: NO</p> <p>Tomas de abrazadera</p> <p>ENTRADA: 1 7/16" SALIDA: 1 7/16"</p> <p>016</p>	<p>ATE8075-44P5 MACK/VOLVO</p>  <p>CNX VISION/VN SERIES AUT 800040, VOL40, 239311, 80040WF,2001-4605</p> <p>PANAL: 43 3/8" X 36 1/2" X 5" CAB. SUP.: 35 7/8" X 3 3/16" CAB. INF.: 35 7/8" X 3 3/16" Enfriador: SI</p> <p>TOMAS: ENTRADA: 2 1/2" SALIDA: 2 1/2"</p> <p>017</p>	 <p>www.phar.com.mx</p>

NOTAS

Large lined area for notes, with a decorative orange wave graphic at the bottom.

Radiadores

PHAR

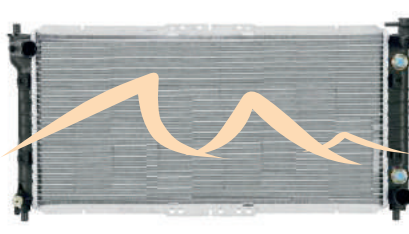
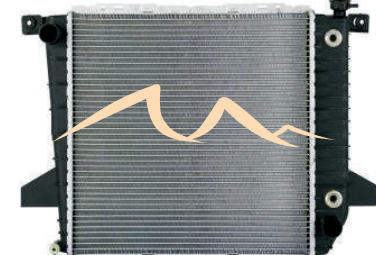
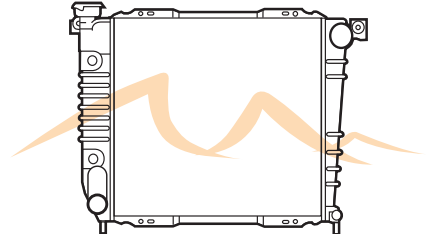
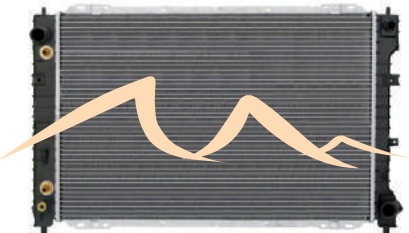
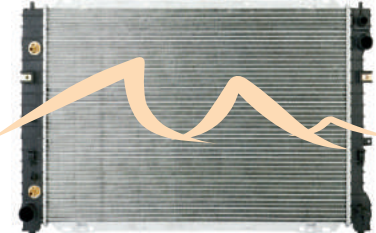
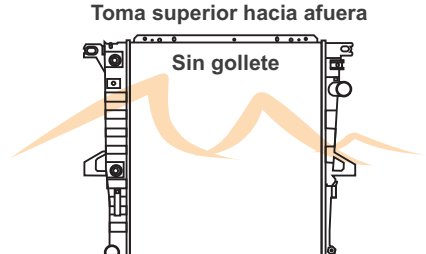
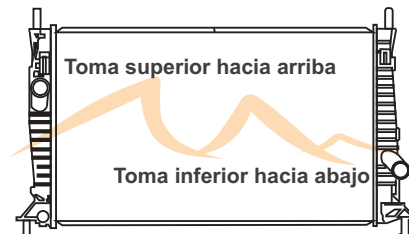
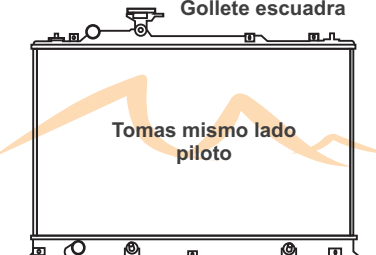
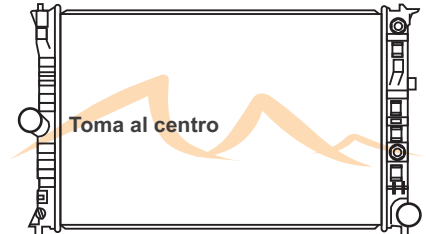

- **MAZDA**
- **MERCEDES BENZ**
- **MINI**
- **MITSUBISHI**

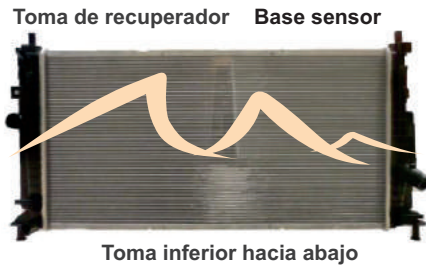
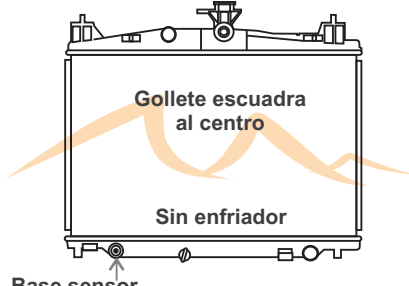
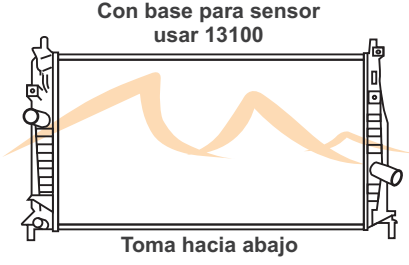
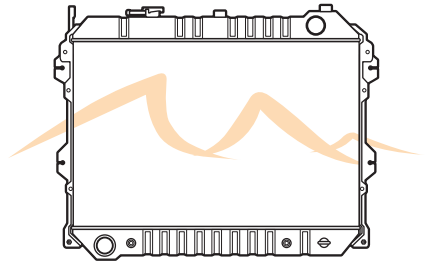
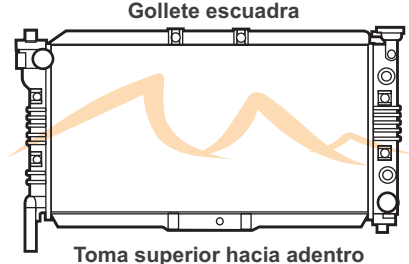
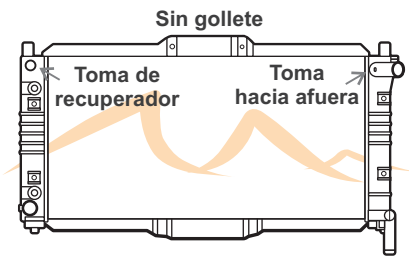
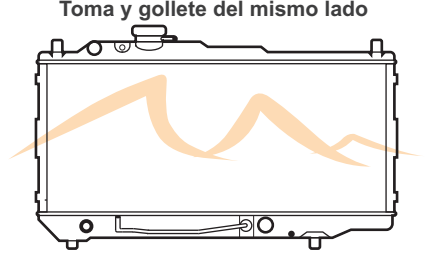
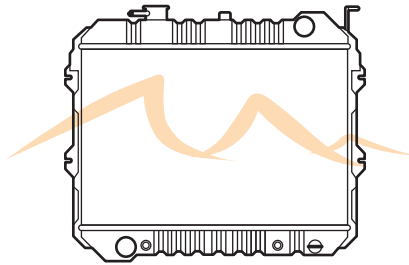
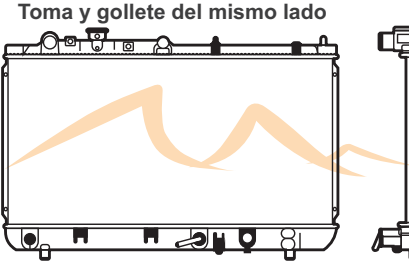
<p>A1323-28C MAZDA</p>  <p>626 93-97/MX-6 92-97 L4 2.0/2.2</p> <p>PANAL: 27 1/8" X 12 3/8" X 1 1/8" CAB. SUP.: 13 11/16" X 1 15/16" CAB. INF.: 13 11/16" X 1 15/16" ENF. TRANS.: SI ENF. MOTOR: NO</p> <p>TOMAS: ENTRADA: 1 3/8" SALIDA: 1 3/8"</p> <p>001</p>	<p>A1726-28C FORD/MAZDA</p>  <p>RANGER 95-97/F100 96-97/MAZDA B2300 95-97 L4 2.3</p> <p>5639 PHAR / DPI 1726</p> <p>PANAL: 18" X 17 7/8" X 1 1/8" CAB. SUP.: 18 7/16" X 1 3/4" CAB. INF.: 18 7/16" X 3 1/16"</p> <p>ENFRIADOR: SI NOTAS: Con montaje de aletas</p> <p>TOMAS: ENTRADA: 1 1/2" SALIDA: 1 1/2"</p> <p>002</p>	<p>A1735-28C MAZDA/FORD</p>  <p>Toma inferior hacia abajo</p> <p>33000/RANGER/EXPLORER/PICK UP 85-94 L4 2.3</p> <p>DPI 1735 / 5634 PHAR</p> <p>PANAL: 18" X 17 3/4" X 1 1/8" CS: 1 7/8" X 18 1/2" CI: 3" X 18 1/2"</p> <p>ENFRIADOR: SI 756347</p> <p>ENTRADA: 1 1/2" SALIDA: 1 1/2"</p> <p>003</p>
<p>A2306-26C FORD/MAZDA</p>  <p>ESCAPE 01-04/ TRIBUTE DX 01-04 L4 2.0</p> <p>PANAL: 27 9/16" X 17 3/4" X 1" CAB. SUP.: 18 1/2" X 1 13/16" CAB. INF.: 18 1/2" X 1 13/16" ENFRIADOR: SI 12"</p> <p>TOMAS: ENTRADA: 1 3/8" SALIDA: 1 3/8"</p> <p>Tomas de calefacción y recuperador</p> <p>004</p>	<p>A2307-26C FORD/MAZDA</p>  <p>ESCAPE 01-08 / TRIBUTE DX 01-06 V6 3.0</p> <p>PANAL: 27 9/16" X 17 3/4" X 1" CAB. SUP.: 18 1/2" X 1 13/16" CAB. INF.: 18 1/2" X 1 13/16" ENFRIADOR: SI 12"</p> <p>TOMAS: ENTRADA: 1 1/4" SALIDA: 1 1/2"</p> <p>Toma de calefacción Toma entrada de motor</p> <p>005</p>	<p>A2470-28C MAZDA/FORD</p>  <p>Toma superior hacia afuera Sin gollete</p> <p>B2300 01-10 / RANGER 01-12 L4 2.3</p> <p>DPI 2470 / 6214 PHAR</p> <p>PANAL: 20 3/4" X 23 1/4" X 1 1/8" CS: 3" X 23 3/4" CI: 3" X 23 3/4"</p> <p>ENFRIADOR: SI</p> <p>ENTRADA: 1 1/2" SALIDA: 1 1/2"</p> <p>006</p>
<p>A2696-28N MAZDA</p>  <p>MAZDA 3 04-09 L4 2.0/2.3</p> <p>DPI 2696</p> <p>PANAL: 27" X 15 3/8" X 1 1/8" CS: 1 13/16" X 15 15/16" CI: 1 13/16" X 15 15/16"</p> <p>ENTRADA: 1 3/8" SALIDA: 1 3/8"</p> <p>ENFRIADOR: NO</p> <p>Toma superior hacia arriba Toma inferior hacia abajo</p> <p>007</p>	<p>A2918-28C MAZDA</p>  <p>Gollete escuadra</p> <p>CX-7 07-12 L4 2.3/2.5</p> <p>DPI 2918</p> <p>PANAL: 17 11/16" X 29 1/4" X 1 1/8" CS: 2" X 30 9/16" CI: 2" X 30 9/16" EDA: SI</p> <p>ENTRADA: 1 1/4" SALIDA: 1 1/4"</p> <p>Tomas mismo lado piloto</p> <p>008</p>	<p>A13088-28C MAZDA</p>  <p>Toma al centro</p> <p>MAZDA 6 "09-10" L4 2.5 V6 3.7</p> <p>DPI 13089</p> <p>PANAL: 25 3/4" X 16 7/8" X 1 1/8" CS: 2 5/16" X 18 1/8" CI: 2 5/16" X 18 1/8"</p> <p>ENTRADA: 1 1/2" SALIDA: 1 1/2"</p> <p>EDA: SI</p> <p>009</p>

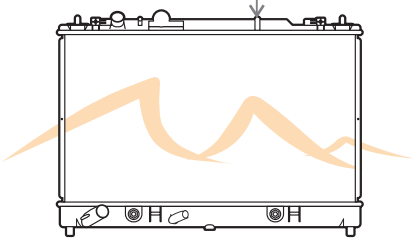
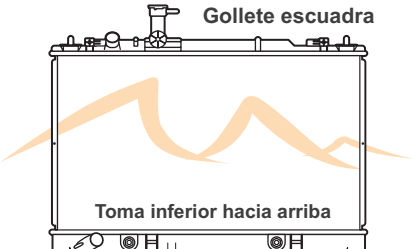
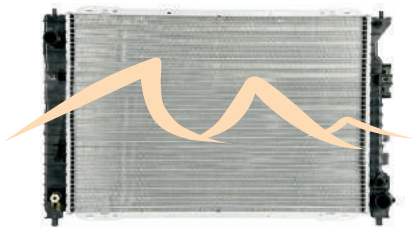
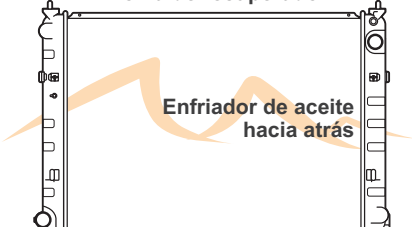
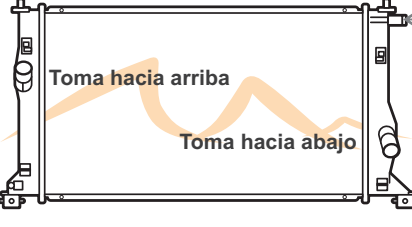
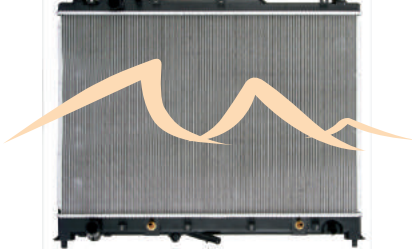
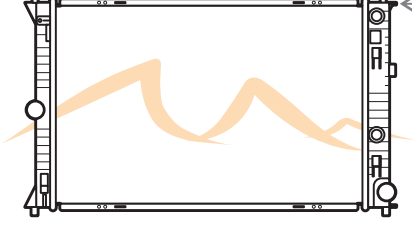
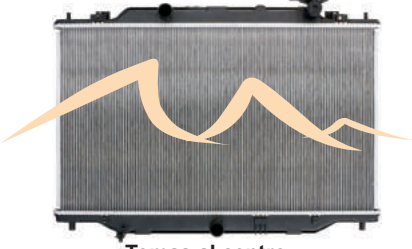
<p>A13100-13N MAZDA</p>  <p>Toma de recuperador Base sensor</p> <p>Toma inferior hacia abajo</p> <p>3 SPORT 10-12</p> <p>DPI 13100 L4 2.0/2.3/2.5</p> <p>PANAL: 26 1/2" X 14 1/8" X 1/2" CAB. SUP.: 15 7/16" X 1 21/32" CAB. INF.: 15 7/16" X 1 21/32" ENF. TRANS.: NO ENF. MOTOR: NO</p> <p>TOMAS: ENTRADA: 1 3/8" SALIDA: 1 3/8"</p> <p>010</p>	<p>A13233-13N MAZDA</p>  <p>Gollete escuadra al centro</p> <p>Sin enfriador</p> <p>Base sensor</p> <p>MAZDA 2 11-15</p> <p>DPI 13233 L4 1.5</p> <p>PANAL: 13 3/4" X 20 1/2" X 1/2" CS: 1 7/8" X 22 15/16" CI: 1 7/8" X 22 15/16" EDA: NO</p> <p>ENTRADA: 1 1/8" SALIDA: 1 1/8"</p> <p>011</p>	<p>A13262-13N MAZDA</p>  <p>Con base para sensor usar 13100</p> <p>Toma hacia abajo</p> <p>MAZDA 3 11-13</p> <p>DPI 13262 L4 2.0/2.3/2.5 M/T</p> <p>PANAL: 26 3/8" X 14 1/4" X 1/2" CS: 1 7/8" X 15 1/2" CI: 1 7/8" X 15 1/2" EDA: NO</p> <p>ENTRADA: 1 5/16" SALIDA: 1 5/16"</p> <p>012</p>
<p>1244 DPI MAZDA</p>  <p>MPV VAN 89-95</p> <p>6124 PHAR L4 2.6 V6 3.0</p> <p>PANAL: 16 7/8" X 25 9/16" X 5/8" (16 mm) CS: 1 7/8" X 26 1/4" CI: 1 7/8" X 26 1/4" EDA: 13 3/4" EDAM: NO MAQ: 2.6 L4/3.0 V6</p> <p>ENTRADA: 1 3/8" SALIDA: 1 5/8"</p> <p>013</p>	<p>1323 DPI MAZDA</p>  <p>Gollete escuadra</p> <p>Toma superior hacia adentro</p> <p>626/MX6 92-97</p> <p>6124 PHAR L4 2.0/2.2</p> <p>PANAL: 27 1/8" X 13 1/2" X 1" (26 mm) CS: 1 7/8" X 13 5/8" CI: 1 7/8" X 13 5/8" EDA: 8 7/8" EDAM: NO NOTAS: CBR Reemplazo 1509</p> <p>ENTRADA: 1 3/8" SALIDA: 1 3/8"</p> <p>014</p>	<p>1326 DPI MAZDA</p>  <p>Sin gollete</p> <p>Toma de recuperador Toma hacia afuera</p> <p>MX-6/626 (26 AT) 93-97</p> <p>6124 PHAR V6 2.5</p> <p>PANAL: 27 1/8" X 13 1/2" X 1" (26 mm) CS: 1 7/8" X 13 5/8" CI: 1 7/8" X 13 5/8" EDA: 8 7/8" EDAM: NO</p> <p>ENTRADA: 1 1/2" SALIDA: 1 1/2"</p> <p>015</p>
<p>1704 DPI MAZDA</p>  <p>Toma y gollete del mismo lado</p> <p>323/PROTEGE 95-98</p> <p>6124 PHAR L4 1.5/1.8</p> <p>PANAL: 12 3/4" X 27 1/4" X 5/8" (16 mm) CS: 2" X 28 1/8" CI: 2" X 28 1/8" EDA: 13 3/4" EDAM: NO</p> <p>ENTRADA: 1 1/8" SALIDA: 1 1/8"</p> <p>016</p>	<p>2063 DPI MAZDA</p>  <p>MPV 96-98</p> <p>6124 PHAR V6 3.0</p> <p>PANAL: 19 5/8" X 25 1/2" X 1 1/4" (32 mm) CS: 1 7/8" X 26 5/16" CI: 1 7/8" X 26 5/16" EDA: 13 3/4" EDAM: NO NOTAS: Substituye ST. 2178</p> <p>ENTRADA: 1 3/8" SALIDA: 1 3/8"</p> <p>017</p>	<p>2303 DPI MAZDA</p>  <p>Toma y gollete del mismo lado</p> <p>PROTEGE 99-03</p> <p>6124 PHAR L4 1.6/1.8/2.0</p> <p>PANAL: 12 13/16" X 26 11/16" X 5/8" (16 mm) CS: 1 7/8" X 27 7/16" CI: 1 7/8" X 27 7/16" EDA: 13 3/4" EDAM: NO</p> <p>ENTRADA: 1 1/8" SALIDA: 1 1/8"</p> <p>018</p>

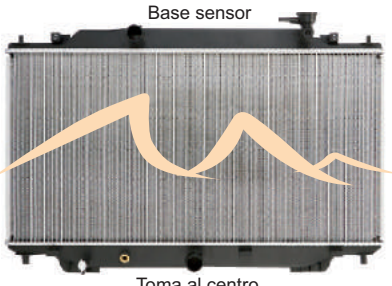
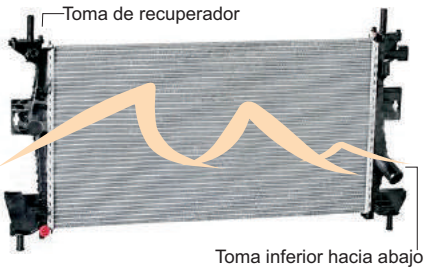
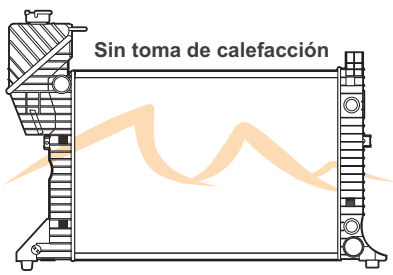
<p>2330 DPI MAZDA</p> <p>Toma de recuperador</p>  <p>MPV 00-01 V6 2.5</p> <p>PANAL: 27 3/16" X 18 1/16" X 5/8" (16 mm) CS: 1 7/8" X 19" CI: 1 7/8" X 19" EDA: 11 13/16" EDAM: NO</p> <p>ENTRADA: 1 1/4" SALIDA: 1 1/2"</p> <p>019</p>	<p>2672 DPI MAZDA</p> <p>Toma de recuperador</p>  <p>MAZDA 6 03-08 V6 3.0</p> <p>PANAL: 14 7/8" X 28 11/16" X 1" (26 mm) CS: 1 7/8" X 29 13/16" CI: 1 7/8" X 29 13/16" EDA: SI</p> <p>ENTRADA: 1 1/4" SALIDA: 1 1/4"</p> <p>020</p>	<p>2673 DPI MAZDA</p> <p>Gollete escuadra</p>  <p>MAZDA 6 03-08 L4 2.3</p> <p>PANAL: 14 7/8" X 28 11/26" X 5/8" (16 mm) CS: 1 7/8" X 29 13/16" CI: 1 7/8" X 29 13/16" EDA: 13 3/4" EDAM: NO</p> <p>ENTRADA: 1 1/4" SALIDA: 1 1/4"</p> <p>021</p>
<p>2762 DPI FORD/MERCURY/MAZDA</p>  <p>ESCAPE/TRIBUTE/MARINER 05-08 DPI 2762 L4 2.3</p> <p>PANAL: 27 9/16" X 17 5/8" X 5/8" CAB. SUP.: 1 13/16" X 18 3/8" CAB. INF.: 1 13/16" X 18 3/8" Enfriador: NO</p> <p>TOMAS: ENTRADA: 1 1/4" SALIDA: 1 7/16"</p> <p>022</p>	<p>2768 DPI MAZDA</p> <p>Toma de recuperador</p>  <p>MPV 02-06 V6 3.0</p> <p>PANAL: 27 3/16" X 18 13/16" X 1" CS: 1 7/8" X 19" CI: 1 7/8" X 19" EDA: SI</p> <p>ENTRADA: 1 1/4" SALIDA: 1 1/2"</p> <p>023</p>	<p>2894 DPI MAZDA</p> <p>Toma de recuperador</p>  <p>MAZDA 5 06-10 L4 2.3</p> <p>PANAL: 25 9/16" X 14 1/2" X 5/8" (16 mm) CS: 1 9/16" X 15 3/4" CI: 1 9/16" X 15 3/4" EDA: SI EDAM: NO</p> <p>ENTRADA: 1 5/16" SALIDA: 1 5/16"</p> <p>024</p>
<p>2986 DPI MAZDA</p>  <p>CX-9 07-15 V6 3.5/3.7</p> <p>PANAL: 19 11/16" X 29 5/16" X 1" CAB. SUP.: 1 7/8" X 30 1/2" CAB. INF.: 1 7/8" X 30 1/2" Enfriador: SI CONCENTRICO</p> <p>TOMAS: ENTRADA: 1 3/8" SALIDA: 1 3/8"</p> <p>025</p>	<p>13089 DPI MAZDA</p> <p>Toma de recuperador</p>  <p>MAZDA 6 09-10 L4 2.5 V6 3.7</p> <p>PANAL: 25 3/4" X 16 9/16" X 5/8" (16 mm) CS: 18" X 2 1/8" CI: 18" X 2 1/8" EDA: SI</p> <p>ENTRADA: 1 1/2" SALIDA: 1 1/2"</p> <p>026</p>	<p>13317 DPI MAZDA</p> <p>Gollete en escuadra</p>  <p>CX-5 13-16 L4 2.0/2.5</p> <p>PANAL: 16 3/4" X 28 5/8" X 5/8" CAB. SUP.: 1 7/8" X 29 11/16" CAB. INF.: 1 7/8" X 29 11/16" Enfriador: NO</p> <p>TOMAS: ENTRADA: 1 3/8" SALIDA: 1 3/8"</p> <p>027</p>

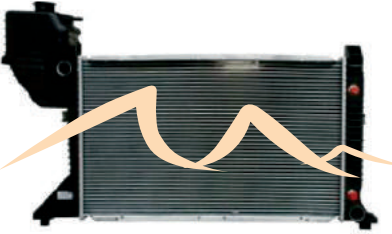
13404 DPI	MAZDA	LHRP841	MAZDA	A007-44C	MERCEDES BENZ
	Base sensor Toma al centro		Toma de recuperador Toma inferior hacia abajo		Sin toma de calefacción
3 14-16 L4 2.0/2.5		3 10-13 L4 1.6/1.8		SPRINTER L5 2.7 V6 3.0/3.5	
PANAL: 14 3/4" X 29 1/8" X 5/8" CS: 1 11/32" X 29 9/16" CI: 1 11/32" X 29 9/16" EDA: NO ENTRADA: 1 5/16" SALIDA: 1 5/16"		PANAL: 26 1/2" X 14 1/4" X 5/8" (16) CS: 1 1/4" X 14 9/16" CI: 1 1/4" X 14 9/16" EDA: NO ENTRADA: 1 3/8" SALIDA: 1 3/8"		PANAL: 26 13/16" X 15 15/16" X 1 3/4" CS: 2 3/8" X 17 1/16" CI: 2 3/8" X 17 1/16" ENFRIADOR: 756621 NOTAS:	
028		029		030	

A2796-28C	MERCEDES BENZ	A2796-44C	MERCEDES BENZ	2290 DPI	MERCEDES BENZ
			Con toma de calefacción		Toma de recuperador Montajes sujeción Toma de calefacción
SPRINTER 04-09		SPRINTER 04-09		E320 98-02	
DPI 2796 L5 2.7 V6 3.0		DPI 2796 L5 2.7 V6 3.0/3.5		V6 3.2	
PANAL: 26 9/16" X 15 3/8" X 1 1/8" CAB. SUP.: 17 1/16" X 2 7/16" CAB. INF.: 17 1/16" X 2 7/16" ENFRIADOR: SI, 10 3/4" 752796-M 07/15 ENTRADA: 1 5/16" SALIDA: 1 9/16"		PANAL: 26 13/16" X 15 15/16" X 1 3/4" CS: 2 3/8" X 17 1/16" CI: 2 3/8" X 17 1/16" ENFRIADOR: SI ENTRADA: 1 3/8" SALIDA: 1 3/8"		PANAL: 25 1/4" X 19 1/4" X 1 1/4" (32 mm) CS: 2 1/2" X 20 1/8" CI: 2 1/2" X 20 1/8" EDA: 12 5/16" 3 PLACAS EDAM: NO ENTRADA: 1 1/2" SALIDA: 1 1/2"	
031		032		033	

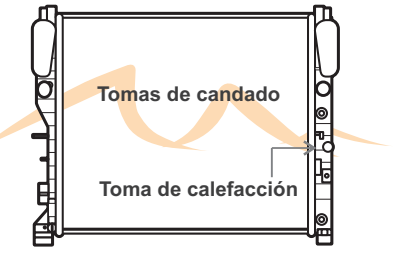
2337 DPI	MERCEDES BENZ	2751 DPI	MERCEDES BENZ	2868 DPI	MERCEDES BENZ
	Tomas de candado		Toma tipo candado		Tomas de candado Toma de calefacción
C280/C350/C230/C240/C320 01-07		CLK350 08-09/SLK300 09-11/SLK350 08-11		E320/E350 03-06/06-09	
L4 1.8 / V6 2.5/2.6/3.0/3.2/3.5 / V8 5.4		V6 3.0/3.5 / V8 5.5		L6 3.2 V6 3.2/3.5	
PANAL: 25 9/16" X 16 5/16" X 1" (26 mm) CS: 2 5/8" X 17 3/4" CI: 2 5/8" X 17 3/4" EDA: SI ENTRADA: 1 3/8" SALIDA: 1 3/8"		PANAL: 25 9/16" X 15 11/16" X 7/8" CS: 1 11/16" X 16 3/8" CI: 1 11/16" X 16 3/8" EDA: SI ENTRADA: 1 7/8" SALIDA: 1 7/8"		PANAL: 25 1/4" X 18 1/4" X 7/8" (22 mm) CS: 2" X 18 9/16" CI: 2" X 18 9/16" EDA: SI (8 PLACAS) ENTRADA: 1 1/2" SALIDA: 1 1/2"	
034		CONDENSADOR: AC3760 035		036	

13254 DPI	MERCEDES BENZ	2747 DPI	MINI	A2410-28C	MITSUBISHI/CHRYSLER/DODGE
SPRINTER 07-13 V6 3.0/3.5		MINI COOPER 02-06 L4 1.6		SEBRING / STRATUS / CIRRUS 01-06 / ECLIPSE 00-05 DPI 2410 V6 2.7/3.0	
PANAL: 26 3/4" X 16 1/16" X 1 1/4" CAB. SUP.: 1 15/16" X 16 11/32" CAB. INF.: 1 15/16" X 16 11/32" Enfriador: SI		PANAL: 22 5/8" X 15 7/8" X 1" (26 mm) CS: 1 7/16" X 16 1/8" CI: 1 7/16" X 16 1/8" EDA: NO		PANAL: 13 3/4" X 27 5/8" X 1/2" CS: 1 7/8" X 29" CI: 1 7/8" X 29" EDA: SI	
037		038		039	

A2675-13C	MITSUBISHI	A2675-28C	MITSUBISHI	A2842-13C	MITSUBISHI
ENDEAVOR 04-11 DPI 2675 V6 3.8		ENDEAVOR 04-11 DPI 2675 V6 3.8		ECLIPSE 06-12 DPI 2842 L4 2.4 V6 3.8	
PANAL: 19 11/16" X 29 5/16" X 1/2" CS: 1 7/8" X 30 1/2" CI: 1 7/8" X 30 1/2" EDA: SI		PANAL: 19 11/16" X 29 13/16" X 1 1/8" CS: 1 7/8" X 30 1/2" CI: 1 7/8" X 30 1/2" EDA: SI		PANAL: 13 3/4" X 29 3/8" X 1/2" CS: 1 9/16" X 30 5/16" CI: 1 9/16" X 30 5/16" EDA: SI	
040		041		042	

A2883-28C	MITSUBISHI/DODGE	A2978-28N	MITSUBISHI	A2979-13N	MITSUBISHI
RAM 05-10/ RAIDER 06-09		LANCER 08-15 / OUTLANDER 07-09 DPI 2978 L4 2.0/2.4 V6 3.0		LANCER 04-14 / OUTLANDER 10-13 DPI 2979 L4 2.0/2.4 V6 3.0	
PANAL: 17 3/4" X 21 1/8" X 1 1/8" CS: 1 7/8" X 22 15/16" CI: 2 1/8" X 22 15/16" EDA: SI		PANAL: 27 9/16" X 16" X 1 1/8" CAB. SUP.: 1 13/16" X 17" CAB. INF.: 1 13/16" X 17" ENF. TRANS.: NO ENF. MOTOR: NO		PANAL: 27 9/16" X 15 9/16" X 1/2" CAB. SUP.: 17" X 1 11/16" CAB. INF.: 17" X 1 11/16" ENFRIADOR: NO 05/15	
043		044		045	

1145 DPI MITSUBISHI/EAGLE/PLYMOUTH

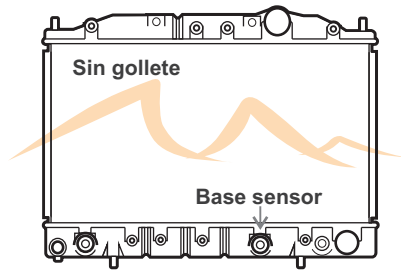

LASER/TALON/ECLIPSE 90-94
L4 1.8/2.0

PANAL: 13 3/4" X 26 1/8" X 1 1/4" (32 mm)
CS: 2" X 27"
CI: 2" X 27"
EDA: 12 3/4"
EDAM: NO

ENTRADA: 1 3/8"
SALIDA: 1 3/8"

046

1393 DPI MITSUBISHI/EAGLE/PLYMOUTH

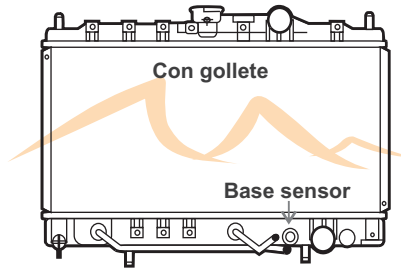

COIT 93-95/SUMMIT/MIRAGE 93-96
L4 1.5/1.8

PANAL: 14 3/4" X 26 1/4" X 1" (26 mm)
CS: 1 7/8" X 26 3/4"
CI: 1 7/8" X 26 3/4"
EDA: 13 3/4"
EDAM: NO

ENTRADA: 1 3/8"
SALIDA: 1 3/8"

NOTAS: Substitute M/T 1956

047

1906 DPI MITSUBISHI

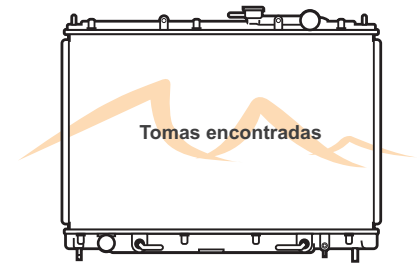

DIAMANTE 97-04
V6 3.5

PANAL: 15 3/4" X 28 1/4" X 1 1/16"
CS: 1 7/8" X 28 15/16"
CI: 1 7/8" X 28 15/16"
EDA: 14 3/4"
EDAM: NO

ENTRADA: 1 3/8"
SALIDA: 1 3/8"

048

1907 DPI MITSUBISHI

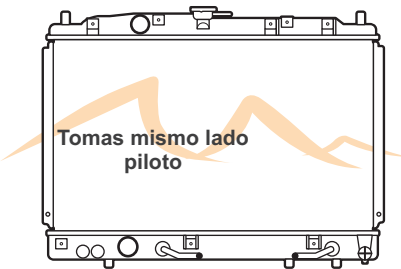

MIRAGE 97-02
L4 1.5/1.8

PANAL: 14 3/4" X 26 1/8" X 5/8" (16 mm)
CS: 1 3/8" X 26 3/4"
CI: 1 7/8" X 26 3/4"
EDA: 11 3/4"
EDAM: NO

ENTRADA: 1 3/8"
SALIDA: 1 3/8"

049

2023 DPI MITSUBISHI/EAGLE

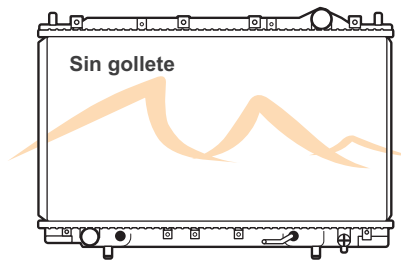

TALON 95-98/SEBRING/ECLIPSE 95-97/95-99
L4 2.0/2.4

PANAL: 13 3/4" X 26 5/8" X 1 1/4"
CS: 2" X 27 1/2"
CI: 2" X 27 1/2"
EDA: 13 3/4"
EDAM: NO

ENTRADA: 1 3/8"
SALIDA: 1 3/8"

050

2024 DPI MITSUBISHI

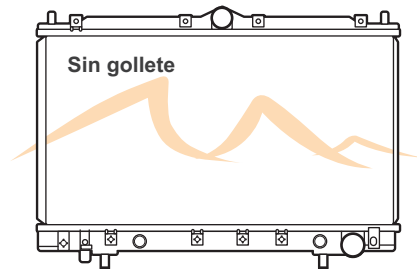

TALON/ECLIPSE 95-98/95-99
L4 2.0

PANAL: 13 3/4" X 26 5/8" X 1 1/8" (28 mm)
CS: 2" X 27 1/2"
CI: 2" X 27 1/2"
EDA: 13 3/4"
EDAM: NO

ENTRADA: 1 3/8"
SALIDA: 1 3/8"

051

2071 DPI MITSUBISHI

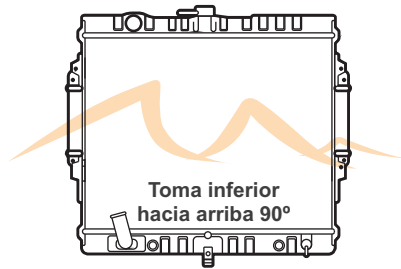

MONTERO SPORT 95-96
V6 3.0

PANAL: 16 3/4" X 23 1/2" X 1 1/4" (32 mm)
CS: 2 9/16" X 23 11/16"
CI: 2 9/16" X 23 11/16"
EDA: 11 13/16" Concéntrico
EDAM: NO

ENTRADA: 1 3/8"
SALIDA: 1 3/8"

052

2073 DPI MITSUBISHI

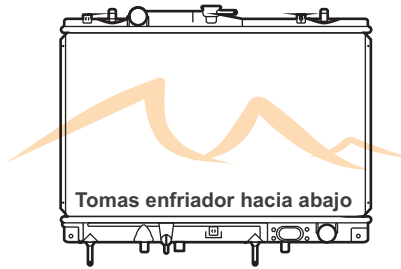

MONTERO SPORT 97-99
L4 2.4

PANAL: 14 3/4" X 25 1/8" X 1" (26 mm)
CS: 2 3/16" X 25 15/16"
CI: 2 3/16" X 25 15/16"
EDA: 13 3/4"
EDAM: NO

ENTRADA: 1 3/8"
SALIDA: 1 3/8"

053

2278 DPI MITSUBISHI

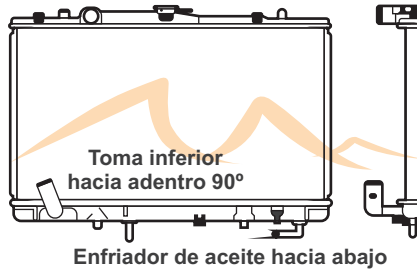





MONTERO SPORT 97-03
V6 3.0/3.5

PANAL: 16 3/4" X 25 1/8" X 1" (26 mm)
CS: 2 3/16" X 25 15/16"
CI: 2 3/16" X 25 15/16"
EDA: 13 3/4"
EDAM: NO

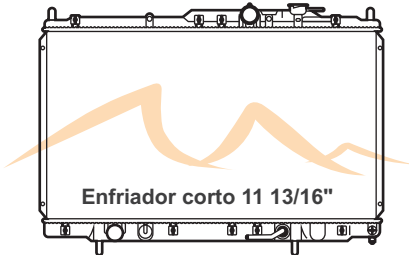
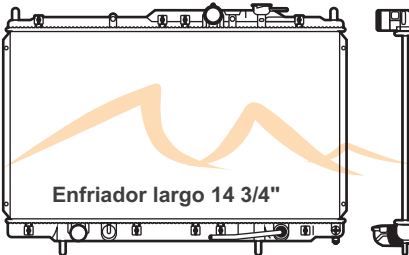
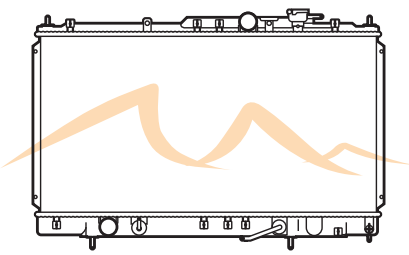
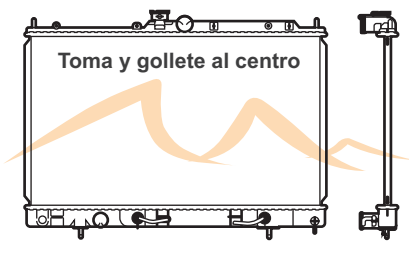
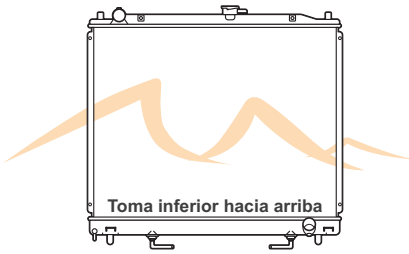
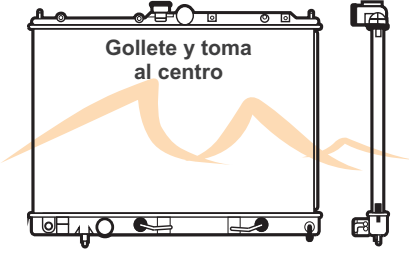
ENTRADA: 1 3/8"
SALIDA: 1 3/8"

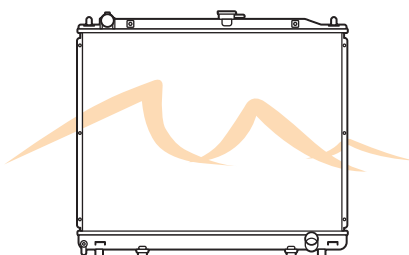
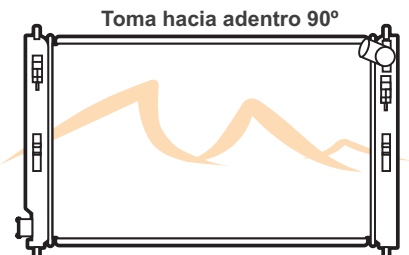
054

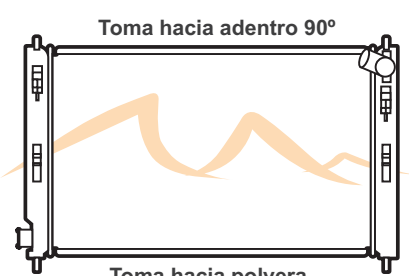
<p>2300 DPI MITSUBISHI</p>  <p>Enfriador corto 11 13/16"</p> <p>GALANT 99-02 L4 2.4</p> <p>PANAL: 14 3/4" X 28 1/4" X 5/8" (16 mm) CS: 1 7/8" X 28 15/16" ENTRADA: 1 3/8" CI: 1 7/8" X 28 15/16" SALIDA: 1 3/8" EDA: 11 13/16" EDAM: NO</p> <p style="text-align: right;">055</p>	<p>2301 DPI MITSUBISHI</p>  <p>Enfriador largo 14 3/4"</p> <p>GALANT 99-02 L4 2.4</p> <p>PANAL: 14 3/4" X 28 1/4" X 5/8" (16 mm) CS: 1 7/8" X 28 15/16" ENTRADA: 1 3/8" CI: 1 7/8" X 28 15/16" SALIDA: 1 3/8" EDA: 14 3/4" EDAM: NO</p> <p style="text-align: right;">056</p>	<p>2406 DPI MISTUBISHI</p>  <p>ECLIPSE 2000 L4 2.4</p> <p>PANAL: 13 3/4" X 27 7/8" X 5/8" (16 mm) CS: 1 7/8" X 28 15/16" ENTRADA: 1 3/8" CI: 1 7/8" X 28 15/16" SALIDA: 1 3/8" EDA: 11 7/8" EDAM: NO</p> <p style="text-align: right;">057</p>
<p>2448 DPI MITSUBISHI</p>  <p>Toma y gollete al centro</p> <p>LANCER 02-07 L4 2.0/2.4</p> <p>PANAL: 14 3/4" X 28" X 5/8" (16 mm) CS: 1 27/32" X 28" ENTRADA: 1 3/8" CI: 1 27/32" X 28" SALIDA: 1 3/8" EDA: 11 7/8" Concéntrico EDAM: NO</p> <p style="text-align: right;">058</p>	<p>2468 DPI MITSUBISHI</p>  <p>Toma inferior hacia arriba Enfriador de aceite hacia abajo</p> <p>MONTERO 01-02 V6 3.5</p> <p>PANAL: 19 11/16" X 27 3/8" X 5/8" (16 mm) CS: 1 9/16" X 28 5/16" ENTRADA: 1 3/8" CI: 1 15/16" X 28 5/16" SALIDA: 1 3/8" EDA: 15 3/8" EDAM: NO</p> <p style="text-align: right;">059</p>	<p>2617 DPI MITSUBISHI</p>  <p>Gollete y toma al centro</p> <p>OUTLANDER 03-06 L4 2.4</p> <p>PANAL: 16 3/4" X 27" X 1" (26 mm) CS: 1 7/8" X 28 1/16" ENTRADA: 1 13/32" CI: 1 7/8" X 28 1/16" SALIDA: 1 13/32" EDA: 11 13/16" EDAM: NO</p> <p style="text-align: right;">060</p>
<p>2676 DPI MITSUBISHI</p>  <p>Toma y gollete al centro</p> <p>M/T LANCER EVOL 03-06 L4 2.0</p> <p>PANAL: 14 3/4" X 27" X 1/4" (36 mm) CS: 2 1/16" X 28 1/16" ENTRADA: 1 13/32" CI: 2 1/16" X 28 11/16" SALIDA: 1 13/32" EDA: NO EDAM: NO</p> <p style="text-align: right;">061</p>	<p>2752 DPI MITSUBISHI</p>  <p>MONTERO 03-06 V6 3.8</p> <p>PANAL: 19 11/16" X 27 3/8" X 1" (26 mm) CS: 1 9/16" X 28 5/16" ENTRADA: 1 3/8" CI: 1 9/16" X 28 5/16" SALIDA: 1 3/8" EDA: 15 3/8" EDAM: NO</p> <p style="text-align: right;">062</p>	<p>2978 DPI MISTUBISHI</p>  <p>Toma hacia adentro 90° Toma hacia polvera</p> <p>LANCER 07-13/OUTLANDER 07-09 L4 2.0/2.4 V6 3.0</p> <p>PANAL: 27 9/16" X 15 13/16" X 1" (26 mm) CS: 1 7/8" X 16 15/16" ENTRADA: 1 3/8" CI: 1 7/8" X 16 15/16" SALIDA: 1 3/8" EDA: NO</p> <p style="text-align: right;">063</p>

2979 DPI	MITSUBISHI	13469 DPI	MITSUBISHI	LHRP169	MITSUBISHI
 <p>Toma hacia adentro 90°</p> <p>Toma hacia polvera</p>		 <p>Toma junto al gollete</p>		 <p>Tomas hacia adentro 45°</p>	
OUTLANDER 10-13/RUR 11-13/LANCER 04-13		MIRAGE 14-17		L200 (TRITON) 2006	
L4 2.0/2.4 V6 3.0		L3 1.2		V6 3.5 A.T.	
PANAL: 27 9/16" X 15 13/16" X 5/8" (16 mm) CS: 1 7/8" X 16 15/16" CI: 1 7/8" X 16 15/16" EDA: NO EDAM: NO		PANAL: 14 3/4" X 18 3/4" X 5/8" CS: 1 5/16" X 19 13/16" CI: 1 9/16" X 19 13/16" EDA: NO		PANAL: 20 11/16" X 25 1/8" X 1" (26mm) CS: 1 7/8" X 25 31/32" CI: 1 7/8" X 25 31/32" EDA: NO	
064		065		066	

NOTAS

NOTAS



Radiadores

PHAR

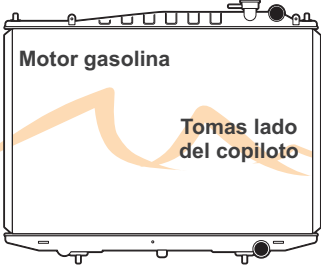
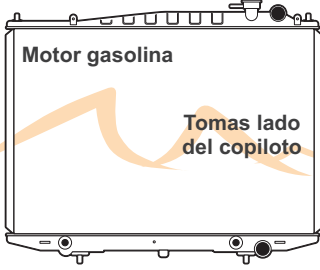
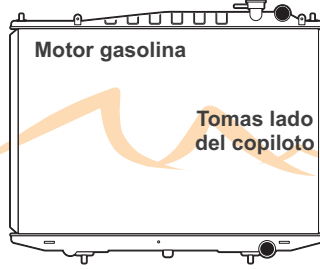
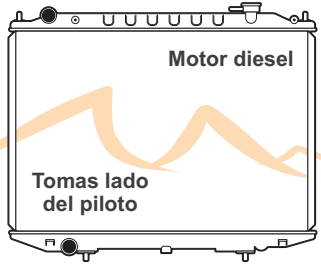
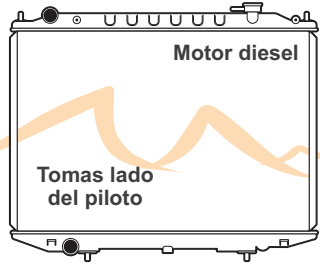
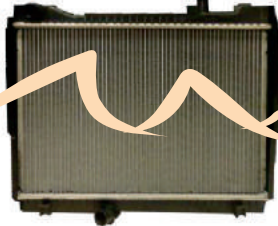
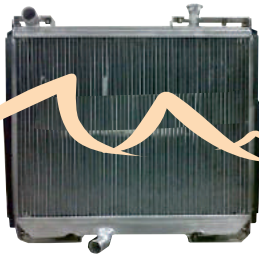
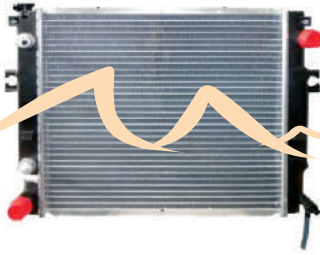
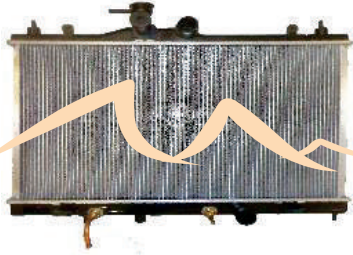

- **NISSAN**
- **OLDSMOBILE**
- **PEUGEOT**

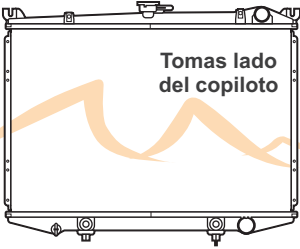
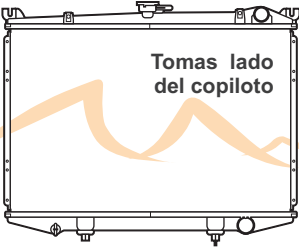
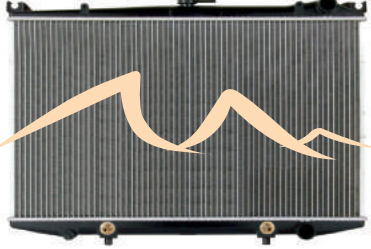
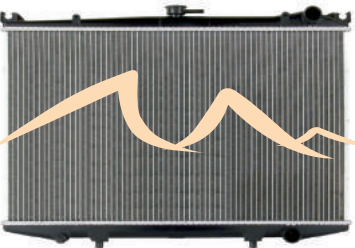
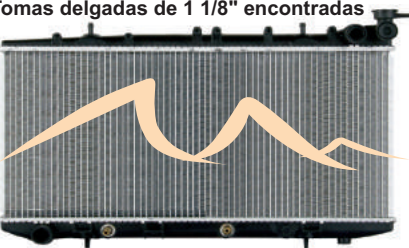
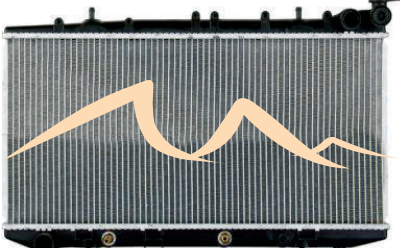
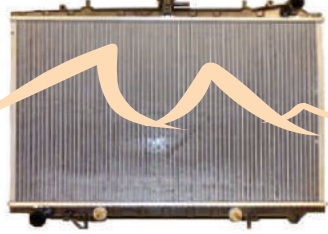
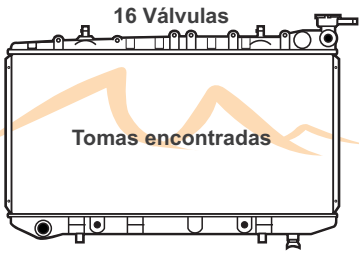
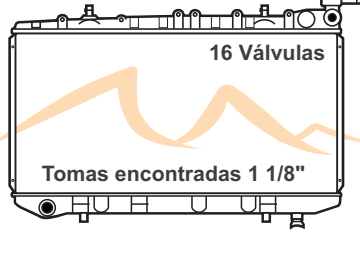

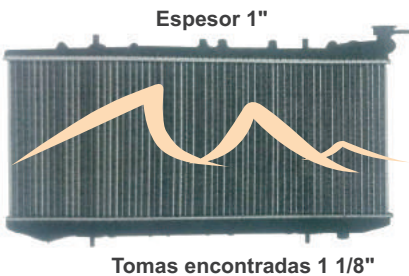
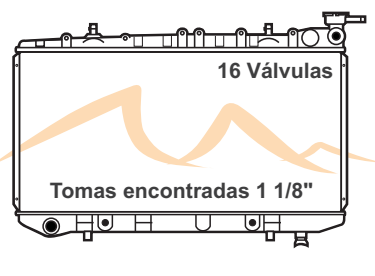
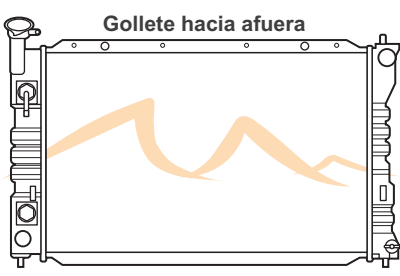
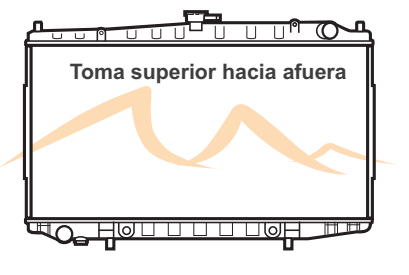
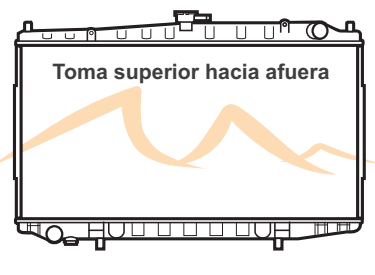
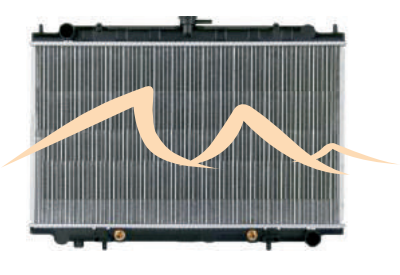
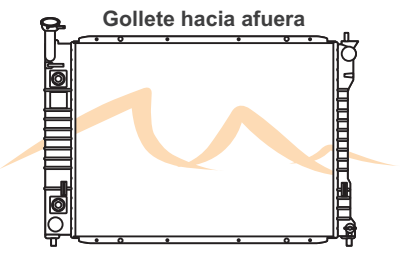
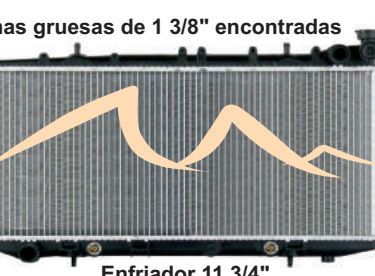
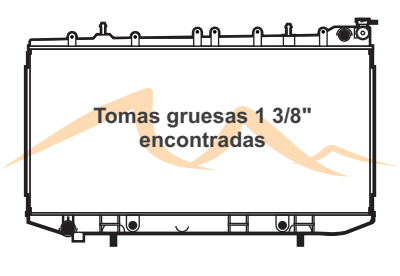
<p>A001-13N NISSAN</p>  <p>Motor gasolina Tomas lado del copiloto</p> <p>D-22 PICK UP GASOLINA 08-12 M/T L4 1.6/1.8/2.2i/2.4/2.5</p> <p>PANAL: 17 3/4" X 27 1/2" X 1/2" CS: 1 13/16" X 28 1/16" ENTRADA: 1 5/16" CI: 1 7/8" X 28 1/8" SALIDA: 1 3/8"</p> <p>ENFRIADOR: NO</p> <p style="text-align: right;">001</p>	<p>A001-28C NISSAN</p>  <p>Motor gasolina Tomas lado del copiloto</p> <p>D-22 PICK UP GASOLINA 08-12 A/T L4 1.6/1.8/2.2i</p> <p>PANAL: 17 3/4" X 27 1/2" X 1 1/8" CS: 1 13/16" X 28 1/16" ENTRADA: 1 5/16" CI: 1 7/8" X 28 1/8" SALIDA: 1 3/8"</p> <p>ENFRIADOR: SI</p> <p style="text-align: right;">002</p>	<p>A001-28N NISSAN</p>  <p>Motor gasolina Tomas lado del copiloto</p> <p>D-22 PICK UP GASOLINA 08-11 M/T L4 1.6/1.8/2.2i/2.4/2.5</p> <p>PANAL: 17 3/4" X 27 1/2" X 1 1/8" ENTRADA: 1 13/16" X 28 1/16" ENTRADA: 1 5/16" SALIDA: 1 7/8" X 28 1/8" SALIDA: 1 3/8"</p> <p>ENFRIADOR: NO</p> <p style="text-align: right;">003</p>
<p>A002-13N NISSAN</p>  <p>Motor diesel Tomas lado del piloto</p> <p>D-22 PICK UP DIESEL 08-12 M/T L4 2.5</p> <p>PANAL: 17 3/4" X 27 1/2" X 1/2" CS: 1 7/8" X 28 1/8" ENTRADA: 1 3/8" CI: 1 7/8" X 28 1/8" SALIDA: 1 3/8"</p> <p>ENFRIADOR: NO</p> <p style="text-align: right;">004</p>	<p>A002-28N NISSAN</p>  <p>Motor diesel Tomas lado del piloto</p> <p>D-22 PICK UP DIESEL 08-12 M/T L4 2.5</p> <p>PANAL: 17 3/4" X 27 1/2" X 1 1/8" CS: 1 7/8" X 28 1/8" ENTRADA: 1 3/8" CI: 1 7/8" X 28 1/8" SALIDA: 1 3/8"</p> <p>ENFRIADOR: NO</p> <p style="text-align: right;">005</p>	<p>A027-28N NISSAN</p>  <p>A027-44N Todo Aluminio Toma 45° lado piloto</p> <p>CABSTAR 07-08 L4 2.5</p> <p>PANAL: 17 3/8" X 22 3/8" X 1 1/8" CAB. SUP.: 2 5/16" X 23 9/16" ENTRADA: 1 3/8" CAB. INF.: 2 5/16" X 23 9/16" SALIDA: 1 3/8"</p> <p>ENFRIADOR: NO</p> <p style="text-align: right;">006</p>
<p>A027-44N NISSAN</p>  <p>Incluye laterales de Sujeción</p> <p>CABSTAR 07-08 L4 2.5 Diesel</p> <p>PANAL: 17 3/4" X 22 53/64" X 1 3/4" CS: 23 1/4" X 2 1/8" ENTRADA: 1 3/8" CI: 23 1/4" X 2 1/8" SALIDA: 1 3/8"</p> <p>ENFRIADOR: NO</p> <p style="text-align: right;">007</p>	<p>A038-44P7 TOYOTA</p>  <p>MONTACARGAS (TUV:SY 1221215)</p> <p>PANAL: 17 3/4" X 17 3/16" X 1 3/4" CAB. SUP.: 2 11/16" X 18 5/16" ENTRADA: 1 5/16" CAB. INF.: 2 11/16" X 18 5/16" SALIDA: 1 5/16"</p> <p>ENFRIADOR: SI, 10 3/4" 113-150</p> <p style="text-align: right;">008</p>	<p>A047-13C NISSAN</p>  <p>TIIDA 07-13 L4 1.6/1.8</p> <p>LHRP173</p> <p>PANAL: 14 15/16" X 22 7/8" X 1/2" CAB. SUP.: 1 7/16" X 24 9/16" ENTRADA: 1 3/8" CAB. INF.: 1 13/16" X 24 9/16" SALIDA: 1 3/8"</p> <p>ENFRIADOR: 8" 752428-M</p> <p style="text-align: right;">009</p>

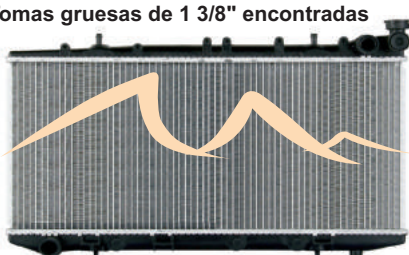
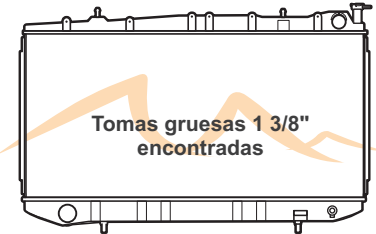
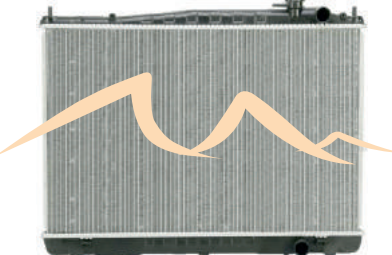
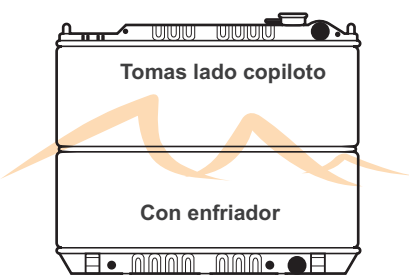
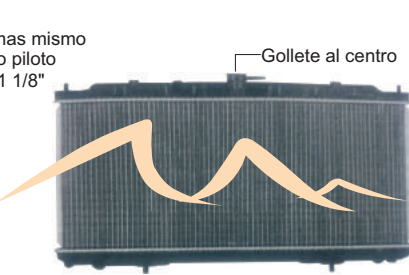
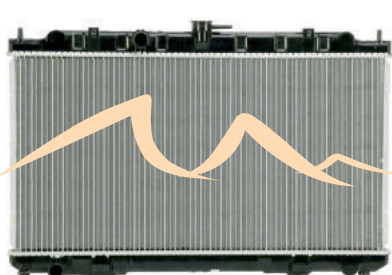
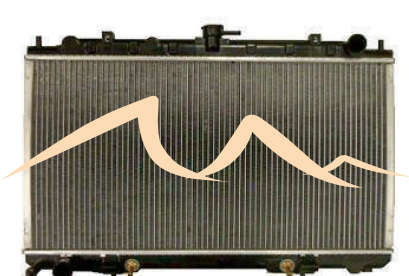
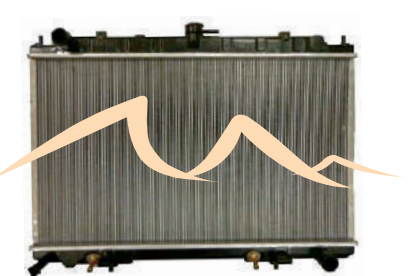
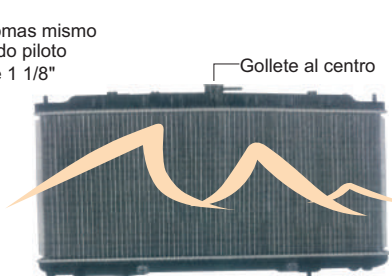

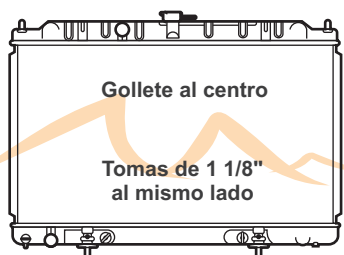
<p>A0314-13C NISSAN</p>  <p>Tomas lado del copiloto</p> <p>HARD BODY 86-09/PICK UP D-21 96-97</p> <p>DPI 314 / 5569 PHAR L4 2.4 V6 3.0</p> <p>PANAL: 16 7/8" X 25 1/2" X 1/2" CS: 1 7/8" X 26 1/4" CI: 1 7/8" X 26 1/4"</p> <p>ENTRADA: 1 3/8" SALIDA: 1 3/8"</p> <p>ENFRIADOR: SI</p> <p style="text-align: right;">010</p>	<p>A0314-13N NISSAN</p>  <p>Tomas lado del copiloto</p> <p>HARD BODY D-21/PICK UP 86-09</p> <p>DPI 314 / 5569 PHAR M/T L4 2.4 V6 3.0</p> <p>PANAL: 16 7/8" X 25 1/2" X 1/2" CS: 1 7/8" X 26 1/4" CI: 1 7/8" X 26 1/4"</p> <p>ENTRADA: 1 3/8" SALIDA: 1 3/8"</p> <p>ENFRIADOR: NO</p> <p style="text-align: right;">011</p>	<p>A0314-26C NISSAN</p>  <p>Tomas lineales mismo lado copiloto</p> <p>PICK UP D21 86-94/PATHFINDER 87-95/PICK UP 95-04</p> <p>5569 PHAR L4 2.4 / V6 3.0</p> <p>PANAL: 16 7/8" X 25 13/16" X 1" CS: 1 7/8" X 26 1/4" CI: 1 7/8" X 26 1/4"</p> <p>ENTRADA: 1 3/8" SALIDA: 1 3/8"</p> <p>ENFRIADOR: SI</p> <p style="text-align: right;">012</p>
<p>A0314-26N NISSAN</p>  <p>Tomas lineales mismo lado copiloto</p> <p>PICK UP D21 86-94/PATHFINDER 87-95/PICK UP 95-04</p> <p>5569 PHAR L4 2.4 / V6 3.0</p> <p>PANAL: 16 7/8" X 25 13/16" X 1" CS: 1 7/8" X 26 1/4" CI: 1 7/8" X 26 1/4"</p> <p>ENTRADA: 1 3/8" SALIDA: 1 3/8"</p> <p>ENFRIADOR: NO</p> <p style="text-align: right;">013</p>	<p>A1152-26C NISSAN</p>  <p>Tomas delgadas de 1 1/8" encontradas</p> <p>Enfriador 7 7/8"</p> <p>SENTRA 91-99/ 200sx 95-98/ TSURU 91-15/ TSUBAME 95-04</p> <p>5571 PHAR L4 1.6/1.8/2.0</p> <p>PANAL: 12 3/8" X 25 3/8" X 1" CAB. SUP.: 26 3/8" X 1 7/8" CAB. INF.: 26 3/8" X 1 7/8"</p> <p>ENFRIADOR: SI</p> <p>TOMAS: ENTRADA: 1 1/8" SALIDA: 1 1/8"</p> <p style="text-align: right;">014</p>	<p>A1152-28C NISSAN</p>  <p>Tomas delgadas de 1 1/8" encontradas</p> <p>SENTRA 91-99 / 200SX 95-98/TSURU 91-15/TSUBAME 95-04</p> <p>5571 PHAR L4 1.6/1.8/2.0</p> <p>PANAL: 12 3/8" X 25 1/2" X 1 1/8" CS: 1 7/8" X 26 3/8" CI: 1 7/8" X 26 3/8"</p> <p>ENTRADA: 1 1/8" SALIDA: 1 1/8"</p> <p>ENF. TRANS: SI 751152-MP</p> <p style="text-align: right;">015</p>
<p>A1242-28C NISSAN</p>  <p>Gollete al centro</p> <p>300ZX 89-96/MAXIMA 89-94</p> <p>DPI 1242 / 5579 PHAR V6 3.0</p> <p>PANAL: 15 3/4" X 27" X 1 1/8" CS: 1 7/8" X 28" CI: 1 7/8" X 28"</p> <p>EDA: 11 3/4" EDAM: NO NOTAS: 1 Línea usar 48</p> <p>ENTRADA: 1 3/8" SALIDA: 1 3/8"</p> <p style="text-align: right;">016</p>	<p>A1426-13C NISSAN</p>  <p>16 Válvulas</p> <p>Tomas encontradas</p> <p>SENTRA/TSURU 93-09</p> <p>DPI 1426 / 5570 PHAR L4 1.6/1.8/2.0 16V.</p> <p>PANAL: 12 5/8" X 25 1/2" X 1/2" CS: 1 3/4" X 26" CI: 1 3/4" X 26"</p> <p>ENTRADA: 1 1/8" SALIDA: 1 1/8"</p> <p>ENFRIADOR: SI 756621 NOTAS: 16 VALVULAS</p> <p style="text-align: right;">017</p>	<p>A1426-13N NISSAN</p>  <p>16 Válvulas</p> <p>Tomas encontradas 1 1/8"</p> <p>SENTRA/TSURU 93-09</p> <p>DPI 1456 / 5570 PHAR M/T L4 1.6/2.0 16V.</p> <p>PANAL: 12 5/8" X 25 1/2" X 1/2" CS: 1 3/4" X 26" CI: 1 3/4" X 26"</p> <p>ENTRADA: 1 1/8" SALIDA: 1 1/8"</p> <p>ENFRIADOR: NO NOTAS: 16 VALVULAS</p> <p style="text-align: right;">018</p>

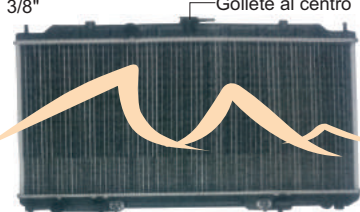
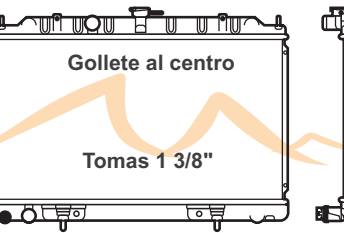
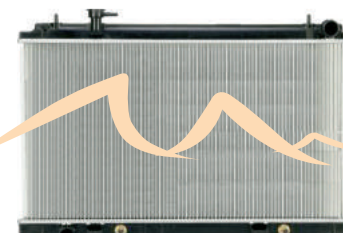
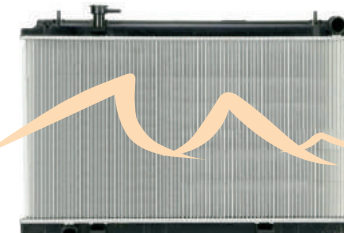
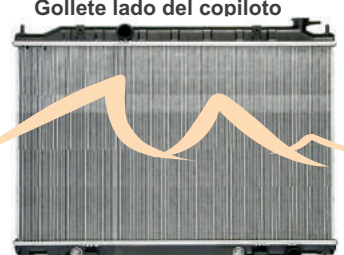
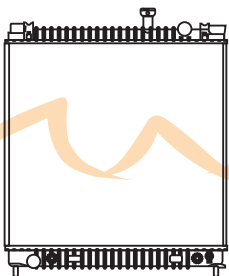
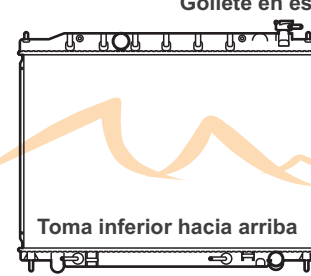

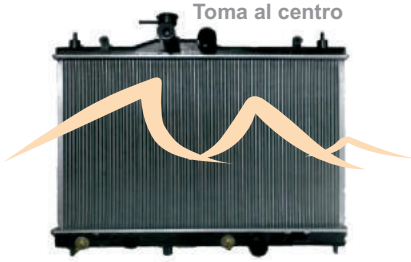
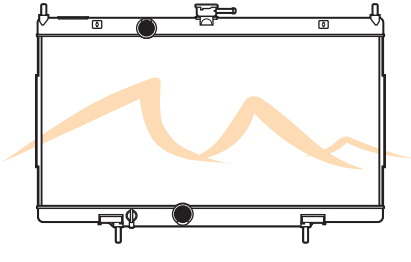
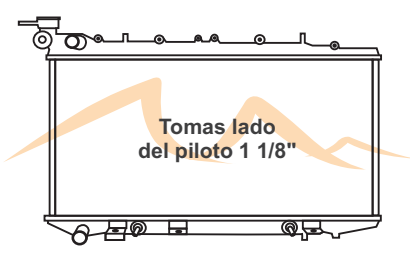
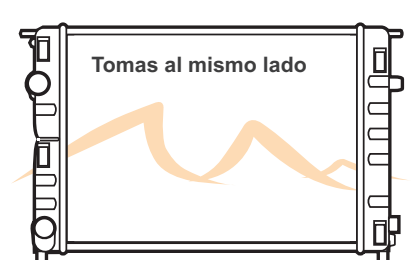
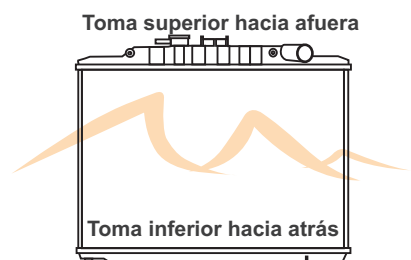
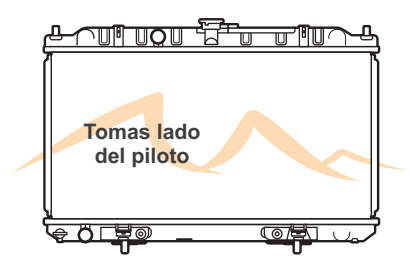
<p>A1426-26N NISSAN</p>  <p>Espeor 1"</p> <p>Tomas encontradas 1 1/8"</p> <p>SENTRA/TSURU 93-09 L4 1.6/2.0</p> <p>PANAL: 12 5/8" X 25 1/2" X 1" CAB. SUP.: 26 1/4" X 1 13/16" CAB INF.: 26 1/4" X 1 13/16" ENF. TRANS.: NO</p> <p>TOMAS: ENTRADA: 1 1/8" SALIDA: 1 1/8"</p> <p>019</p>	<p>A1426-26C NISSAN</p>  <p>16 Válvulas</p> <p>Tomas encontradas 1 1/8"</p> <p>SENTRA/TSURU 93-09 L4 1.6/2.0 16V.</p> <p>DPI 1426 / 5570 PHAR</p> <p>PANAL: 12 5/8" X 25 1/2" X 1 1/8" CS: 1 3/4" X 26" CI: 1 3/4" X 26"</p> <p>ENTRADA: 1 1/8" SALIDA: 1 1/8"</p> <p>ENFRIADOR: SI 756621 NOTAS: 16 VALVULAS</p> <p>020</p>	<p>A1511-28C NISSAN/MERCURY</p>  <p>Gollete hacia afuera</p> <p>QUEST/VILLAGER 93-95 V6 3.0</p> <p>DPI 1511</p> <p>PANAL: 25 3/8" X 18 1/4" X 1 1/8" CS: 1 7/8" X 18 1/2" CI: 3 1/8" X 18 1/2"</p> <p>ENTRADA: 1 3/8" SALIDA: 1 3/8"</p> <p>ENFRIADOR: SI</p> <p>021</p>
<p>A1573-28C NISSAN/MERCURY</p>  <p>Toma superior hacia afuera</p> <p>A/T ALTIMA 93-00 L4 2.4</p> <p>DPI 1573 / 5575 PHAR</p> <p>PANAL: 15 1/8" X 27 1/8" X 1 1/8" CS: 1 7/8" X 28 1/8" CI: 1 7/8" X 28 1/8"</p> <p>ENTRADA: 1 3/8" SALIDA: 1 3/8"</p> <p>ENFRIADOR: SI 756621 NOTAS: PANAL GRUESO</p> <p>022</p>	<p>A1573-28N NISSAN</p>  <p>Toma superior hacia afuera</p> <p>M/T ALTIMA 93-00 L4 2.4</p> <p>DPI 1573 / 5575 PHAR</p> <p>PANAL: 15 1/8" X 27 1/8" X 1 1/8" CS: 1 7/8" X 28 1/8" CI: 1 7/8" X 28 1/8"</p> <p>ENTRADA: 1 3/8" SALIDA: 1 3/8"</p> <p>ENFRIADOR: NO NOTAS:</p> <p>023</p>	<p>A1752-28C NISSAN</p>  <p>INFINITI 96-99/MAXIMA 95-99 V6 3.0</p> <p>DPI 1752 / 6025 PHAR</p> <p>PANAL: 15 3/4" X 26 3/4" X 1 1/8" CS: 2" X 28 1/8" CI: 2" X 28 1/8"</p> <p>ENTRADA: 1 3/8" SALIDA: 1 3/8"</p> <p>ENFRIADOR: SI</p> <p>024</p>
<p>A1924-28C NISSAN/MERCURY</p>  <p>Gollete hacia afuera</p> <p>QUEST/VILLAGER 96-98 V6 3.0</p> <p>DPI 1924 / 6030 PHAR</p> <p>PANAL: 25 3/8" X 18 3/8" X 1 1/8" CS: 3" X 18 1/2" CI: 3" X 18 1/2"</p> <p>ENTRADA: 1 3/8" SALIDA: 1 3/8"</p> <p>ENFRIADOR: SI</p> <p>025</p>	<p>A1976-26C NISSAN</p>  <p>Tomas gruesas de 1 3/8" encontradas</p> <p>Enfriador 11 3/4"</p> <p>SENTRA / LUCINO / TSURU 94-00 L4 1.6/1.8/2.0</p> <p>6217 PHAR</p> <p>PANAL: 12 3/8" X 25 3/8" X 1" CAB. SUP.: 26 3/8" X 1 7/8" CAB. INF.: 26 3/8" X 1 7/8" ENFRIADOR: SI</p> <p>TOMAS: ENTRADA: 1 3/8" SALIDA: 1 3/8"</p> <p>026</p>	<p>A1976-28C NISSAN</p>  <p>Tomas gruesas 1 3/8" encontradas</p> <p>A/T SENTRA/LUCINO/TSURU 94-00 L4 1.6/1.8/2.0</p> <p>DPI 1976 / 6217 PHAR</p> <p>PANAL: 12 1/2" X 25 17/32" X 1 1/8" CS: 1 7/8" X 26 1/4" CI: 1 7/8" X 26 1/4"</p> <p>ENTRADA: 1 3/8" SALIDA: 1 3/8"</p> <p>MAQ. 98 1.6 LT. L4/MAQ. 122 2.0 LT. L4 ENFRIADOR: 756621</p> <p>027</p>

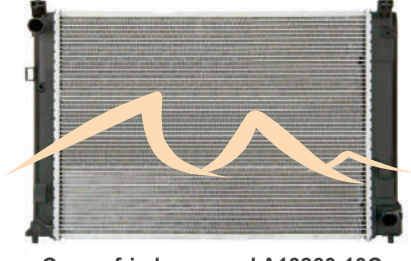
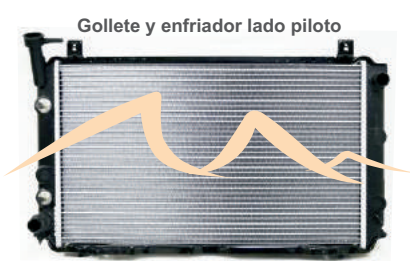

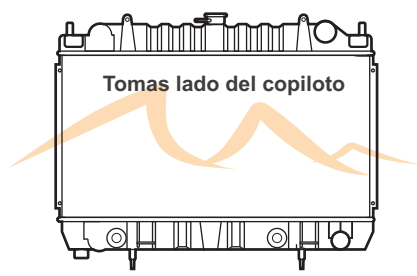
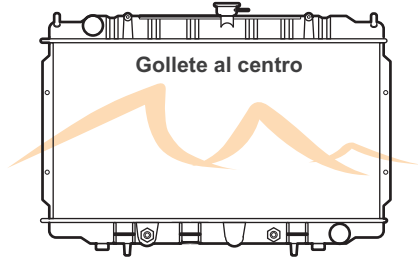

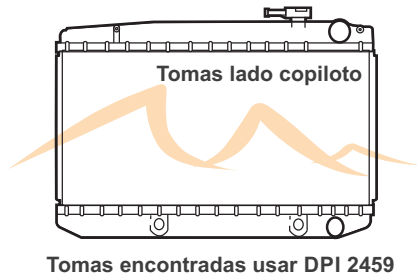
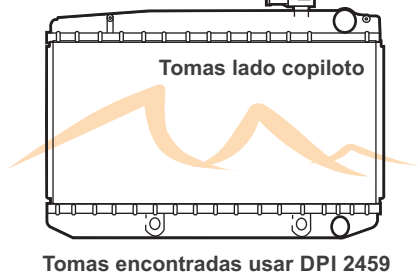
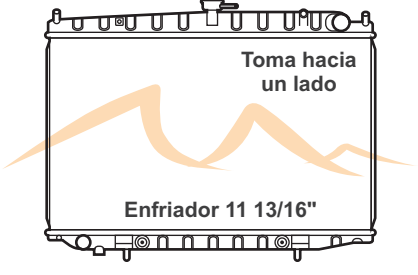
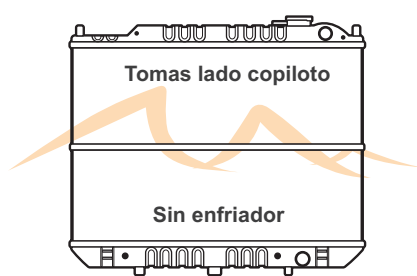
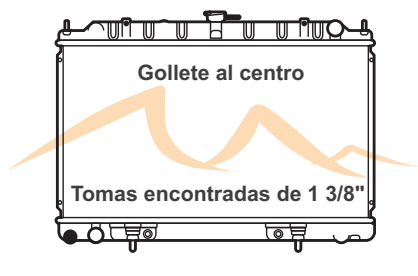
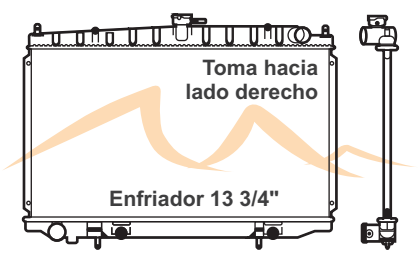

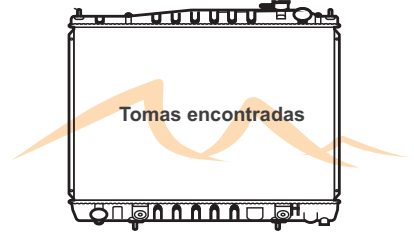
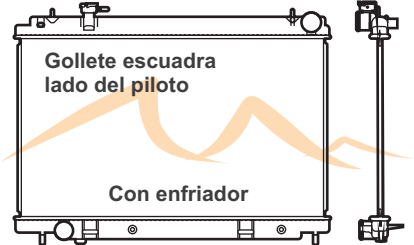
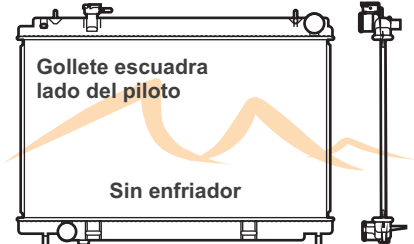
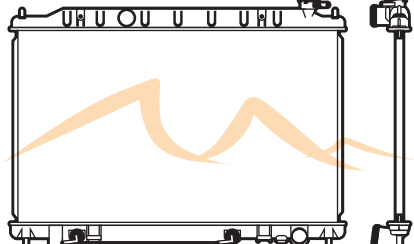
<p>A1978-26N NISSAN</p> <p>Tomas gruesas de 1 3/8" encontradas</p>  <p>SENTRA / LUCINO / TSURU 94-00 6217 PHAR L4 1.6/1.8/2.0</p> <p>PANAL: 12 3/8" X 25 3/8" X 1" CAB. SUP.: 26 3/8" X 1 7/8" CAB. INF.: 26 3/8" X 1 7/8" ENFRIADOR: NO</p> <p>TOMAS: ENTRADA: 1 3/8" SALIDA: 1 3/8"</p> <p>028</p>	<p>A1978-28N NISSAN</p>  <p>Tomas gruesas 1 3/8" encontradas</p> <p>M/T SENTRA/LUCINO/TSURU 94-00 DPI 1978 / 6217 PHAR L4 1.6/1.8/2.0</p> <p>PANAL: 12 1/2" X 25 17/32" X 1 1/8" CS: 1 7/8" X 26 1/4" CI: 1 7/8" X 26 1/4"</p> <p>ENTRADA: 1 3/8" SALIDA: 1 3/8"</p> <p>ENFRIADOR: NO</p> <p>029</p>	<p>A2151-28N NISSAN</p>  <p>XTERRA 00-04/FRONTIER 98-04 PHAR 6216 V6 3.3 / L4 2.4</p> <p>PANAL: 17 5/8" X 26 7/8" X 1 1/8" CAB. SUP.: 28" X 1 13/16" CAB. INF.: 28" X 1 13/16" ENF. TRANS.: NO ENF. MOTOR: NO</p> <p>TOMAS: ENTRADA: 1 3/8" SALIDA: 1 3/8"</p> <p>030</p>
<p>A2215-28C NISSAN</p>  <p>Tomas lado copiloto</p> <p>Con enfriador</p> <p>FRONTIER 00-04/XTERRA 98-04 L4 2.4 V6 3.3</p> <p>PANAL: 17 11/16" X 28 1/8" X 1" (26 mm) CS: 1 7/8" X 28 1/16" CI: 2 1/4" X 28 11/16" EDA: 14 3/4" EDAM: NO</p> <p>ENTRADA: 1 3/8" SALIDA: 1 3/8"</p> <p>031</p>	<p>A2327-13N NISSAN</p>  <p>Tomas mismo lado piloto de 1 1/8"</p> <p>Gollete al centro</p> <p>Sin enfriador</p> <p>SENTRA 00-06 L4 1.8</p> <p>PANAL: 14 1/8" X 26 7/8" X 1/2" CS: 28 1/16" X 1 7/8" CI: 28 1/16" X 1 7/8" EDA: NO</p> <p>ENTRADA: 1 1/8" SALIDA: 1 1/8"</p> <p>032</p>	<p>A2327-28N NISSAN</p>  <p>SENTRA 00-06 DPI 2327/ 6105 PHAR L4 1.8</p> <p>PANAL: 14 1/8" X 27 1/16" X 1 1/8" CS: 1 7/8" X 28 1/16" CI: 1 7/8" X 28 1/16" ENFRIADOR: NO</p> <p>ENTRADA: 1 1/8" SALIDA: 1 1/8"</p> <p>033</p>
<p>A2328-28C NISSAN</p>  <p>SENTRA 00-01 L4 2.0</p> <p>PANAL: 14 1/8" X 26 27/32" CS: 1 7/8" X 28 1/16" CI: 1 7/8" X 28 1/16" EDA: SI</p> <p>ENTRADA: 1 3/8" SALIDA: 1 3/8"</p> <p>034</p>	<p>A2329-28C NISSAN/INFINITI</p>  <p>MAXIMA 00-03 / I30, I35 00-04 V6 3.0/3.5</p> <p>PANAL: 15 3/4" X 27 1/16" X 1 1/8" CS: 1 3/8" X 28 1/8" CI: 1 13/16" X 28"</p> <p>ENTRADA: 1 3/8" SALIDA: 1 3/8"</p> <p>EDA: SI EDAM: NO</p> <p>035</p>	<p>A2346-13C NISSAN</p>  <p>Tomas mismo lado piloto de 1 1/8"</p> <p>Gollete al centro</p> <p>SENTRA 00-06 L4 1.8</p> <p>PANAL: 14 1/8" X 26 7/8" X 1/2" CS: 28 1/16" X 1 7/8" CI: 28 1/16" X 1 7/8" EDA: SI 11 7/8"</p> <p>ENTRADA: 1 1/8" SALIDA: 1 1/8"</p> <p>036</p>

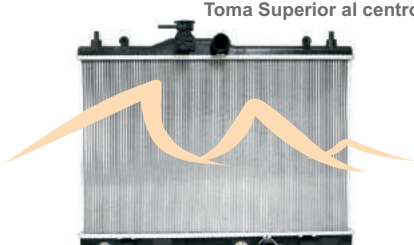
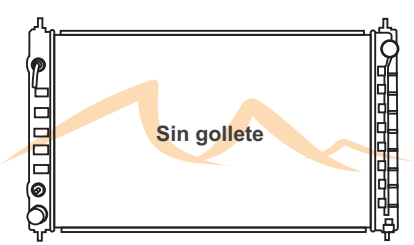

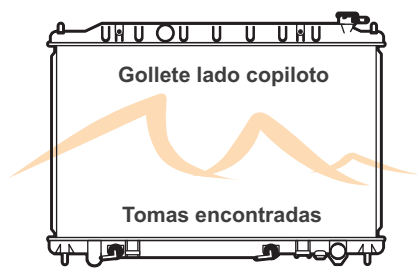
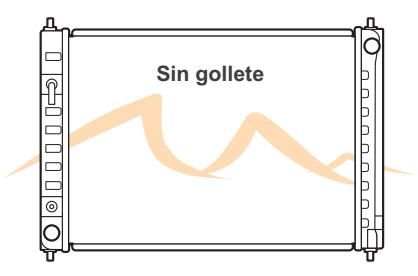
<p>A2346-28C NISSAN</p>  <p>Gollete al centro Tomas de 1 1/8" al mismo lado</p> <p>A/T SENTRA 00-06 L4 1.8</p> <p>DPI 2346 / 6105 PHAR</p> <p>PANAL: 14 1/8" X 27" X 1 1/8" CS: 1 7/8" X 28 1/16" CI: 1 7/8" X 28 1/16"</p> <p>ENTRADA: 1 1/8" SALIDA: 1 1/8"</p> <p>ENFRIADOR: SI</p> <p>037</p>	<p>A2414-28C NISSAN</p>  <p>Tomas encontradas usar DPI 2415</p> <p>ALTIMA 02-06 L4 2.5</p> <p>DPI 2414</p> <p>PANAL: 15 3/4" X 29 1/4" X 1 1/8" CS: 1 27/32" X 29 27/32" CI: 1 27/32" X 29 27/32"</p> <p>ENTRADA: 1 3/8" SALIDA: 1 3/8"</p> <p>ENFRIADOR: SI CONDENSADOR: AC3057</p> <p>038</p>	<p>A2469-13C NISSAN</p>  <p>Tomas mismo lado piloto de 1 3/8" Gollete al centro</p> <p>SENTRA 02-06 L4 2.5</p> <p>DPI 2469 / 6105 PHAR</p> <p>PANAL: 14 1/8" X 26 7/8" X 1/2" CS: 28 1/16" X 1 7/8" CI: 28 1/16" X 1 7/8" EDA: SI 11 7/8"</p> <p>ENTRADA: 1 3/8" SALIDA: 1 3/8"</p> <p>039</p>
<p>A2469-28C NISSAN</p>  <p>Gollete al centro Tomas 1 3/8"</p> <p>A/T SENTRA 02-06 L4 2.5</p> <p>DPI 2469 / 6105 PHAR</p> <p>PANAL: 14 1/16" X 27 3/16" X 1 1/8" CAB. SUP.: 29 13/16" X 1 7/8" CI: 1 15/16" X 28 1/8"</p> <p>ENTRADA: 1 3/8" SALIDA: 1 3/8"</p> <p>ENFRIADOR: SI</p> <p>040</p>	<p>A2576-13C NISSAN</p>  <p>BASE/TOURING 03-06/TRACK 04-06 BASE 03-06/ ENTHUSIAST 04-06/350Z 03-06 V6 3.5</p> <p>DPI 2576</p> <p>PANAL: 15 3/4" X 28 7/16" X 1/2" CAB. SUP.: 1 7/8" X 29 13/16" CAB. INF.: 1 7/8" X 29 13/16"</p> <p>ENF. TRANS.: SI ENF. MOTOR: NO</p> <p>TOMAS: ENTRADA: 1 3/8" SALIDA: 1 3/8"</p> <p>041</p>	<p>A2577-13N NISSAN</p>  <p>350Z 03-05/BASE/TOURING 03-06 PERFORMANCE 03-05/TRACK/ENTHUSIAST 04-06 V6 3.5</p> <p>DPI 2577</p> <p>PANAL: 15 3/4" X 28 7/16" X 1/2" CAB. SUP.: 1 7/8" X 29 13/16" CAB. INF.: 1 7/8" X 29 13/16"</p> <p>ENF. TRANS.: NO ENF. MOTOR: NO</p> <p>TOMAS: ENTRADA: 1 3/8" SALIDA: 1 3/8"</p> <p>042</p>
<p>A2692-28C NISSAN</p>  <p>Gollete lado del copiloto</p> <p>QUEST 04-09 V6 3.5</p> <p>DPI 2692</p> <p>PANAL: 17 3/4" X 28 1/2" CAB. SUP.: 29 13/16" X 1 7/8" CAB. INF.: 29 7/8" X 1 13/16"</p> <p>ENF. TRANS.: SI ENF. MOTOR: NO</p> <p>TOMAS: ENTRADA: 1 3/8" SALIDA: 1 3/8"</p> <p>043</p>	<p>A2691-44C NISSAN/INFINITI</p>  <p>Qx56 04-10/PATHFINDER 04/ARMADA/TITAN V8 5.6</p> <p>DPI 2691</p> <p>PANAL: 23 5/8" X 26 3/4" X 1 3/4" CS: 3" X 27 3/8" CI: 3" X 27 3/8"</p> <p>ENTRADA: 1 3/8" SALIDA: 1 3/8"</p> <p>ENFRIADOR: SI CONDENSADOR: AC3239</p> <p>044</p>	<p>A2578-28C NISSAN</p>  <p>Gollete en escuadra Toma inferior hacia arriba</p> <p>MURANO 03-07 V6 3.5</p> <p>DPI 2578</p> <p>PANAL: 17 11/16" X 28 11/16" X 1 1/8" CS: 1 7/8" X 29 13/16" CI: 1 7/8" X 29 13/16"</p> <p>ENTRADA: 1 13/32" SALIDA: 1 13/32"</p> <p>ENFRIADOR: SI</p> <p>045</p>

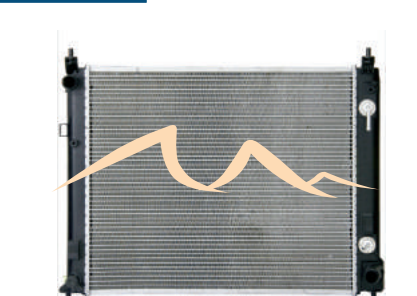
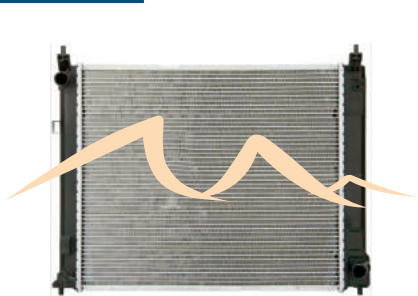

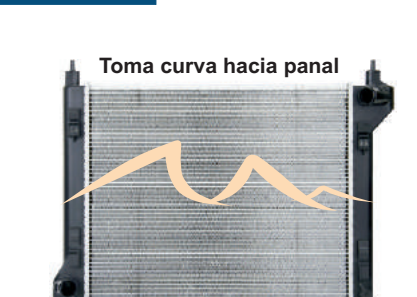
<p>A2981-13C NISSAN</p>  <p>Toma al centro</p> <p>TIIDA 07-11 / VERSA 07-11</p> <p>DPI 2981 L4 1.6/1.8</p> <p>PANAL: 14 15/16" X 23 1/8" X 1/2" CAB. SUP.: 1 3/8" X 24 3/16" ENTRADA: 1 3/8" CAB. INF.: 1 7/8" X 24 3/16" SALIDA: 1 3/8"</p> <p>ENFRIADOR: SI CONDENSADOR: AC3594 046</p>	<p>A2998-13N NISSAN</p>  <p>M/T SENTRA 07-12</p> <p>DPI 2998 L4 2.0/2.5</p> <p>PANAL: 14 3/4" X 27 1/4" X 1/2" CS: 1 3/16" X 27 3/16" ENTRADA: 1 3/8" CI: 1 3/16" X 27 3/16" SALIDA: 1 3/8"</p> <p>ENFRIADOR: NO CONDENSADOR: AC3628 047</p>	<p>A5571-28C NISSAN</p>  <p>Tomas lado del piloto 1 1/8"</p> <p>A/T TSURU III 94-02</p> <p>5571 PHAR L4 1.6 8V</p> <p>PANAL: 12 5/8" X 24 3/4" X 1 1/8" CS: 1 13/16" X 26 1/4" ENTRADA: 1 1/8" CI: 1 13/16" X 26 5/16" SALIDA: 1 1/8"</p> <p>ENFRIADOR: SI NOTA: 8 VALVULAS 048</p>
<p>A6207-28N NISSAN/RENAULT</p>  <p>Tomas al mismo lado</p> <p>M/T CLIO/PLATINA 02-07</p> <p>6207 PHAR L4 1.6</p> <p>PANAL: 18 7/8" X 15 5/16" X 1 1/8" CS: 1 5/8" X 16 1/4" ENTRADA: 1 1/4" CI: 1 5/8" X 16 1/4" SALIDA: 1 1/4"</p> <p>MAQ. 110 1.6 LT. L4 16 VAL. ENFRIADOR: NO 049</p>	<p>A6212-28N NISSAN</p>  <p>Toma superior hacia afuera Toma inferior hacia atrás</p> <p>URVAN 02-08</p> <p>6212 PHAR I4 2.4/2.5</p> <p>PANAL: 14 3/16" X 21 9/16" X 1 1/8" CS: 2 X 22 3/8" ENTRADA: 1 3/8" CI: 2 X 22 3/8" SALIDA: 1 3/8"</p> <p>ENFRIADOR: NO NOTA: 12 VALVULAS 050</p>	<p>A6218-28C NISSAN</p>  <p>Tomas lado del piloto</p> <p>X-TRAIL 01-07</p> <p>6218 PHAR L4 2.0/2.3/2.5</p> <p>PANAL: 17 3/4" X 27 1/8" X 1 1/8" CS: 1 7/8" X 28" ENTRADA: 1 3/8" CI: 1 7/8" X 28" SALIDA: 1 3/8"</p> <p>ENFRIADOR: SI 756381 051</p>
<p>A13260-13C NISSAN</p>  <p>Sin enfriador usar A13261-13N</p> <p>MARCH 15-17/MICRA 15-17/NOTE 14-17/ TIIDA 12-17/VERSA 12-17</p> <p>L4 1.6/1.8</p> <p>PANAL: 20" X 16 3/16" X 1/2" CAB. SUP.: 1 13/16" X 17 5/8" TOMAS: CAB. INF.: 1 13/16" X 17 5/8" ENTRADA: 1 1/8" ENFRIADOR: SI 10 1/2" SALIDA: 1 1/8" 052</p>	<p>A13261-13N NISSAN</p>  <p>Con enfriador usar el A13260-13C</p> <p>MARCH 15-17/MICRA 15-17/NOTE 14-17/ TIIDA 12-17/VERSA 12-17</p> <p>L4 1.6/1.8</p> <p>PANAL: 20" X 16 3/16" X 1/2" CAB. SUP.: 1 13/16" X 17 5/8" TOMAS: CAB. INF.: 1 13/16" X 17 5/8" ENTRADA: 1 1/8" ENFRIADOR: NO SALIDA: 1 1/8" 053</p>	<p>0788 DPI NISSAN</p>  <p>Gollete y enfriador lado piloto</p> <p>SENTRA/PULSAR/TSURU 89-90</p> <p>L4 1.6</p> <p>PANAL: 23 1/8" X 13 3/4" X 1" CS: 2 1/16" X 14 3/8" ENTRADA: 1 1/8" CI: 2 1/16" X 14 3/8" SALIDA: 1 1/8" EDA: SI Concentrico EDAM: NO 054</p>

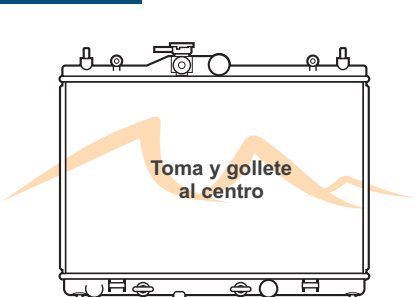
<p>1751 DPI NISSAN</p>  <p>Tomas lado del copiloto</p> <p>240SX 95-98 L4 2.4</p> <p>PANAL: 14 1/4" X 25 3/8" X 1" (26 mm) CS: 1 7/8" X 26 1/4" ENTRADA: 1 3/8" CI: 1 7/8" X 26 1/4" SALIDA: 1 3/8" EDA: 13 3/4" EDAM: NO</p> <p>055</p>	<p>1752 DPI NISSAN/INFINITI</p>  <p>Gollete al centro</p> <p>MAXIMA/i130 95-00 V6 3.0</p> <p>PANAL: 15 3/4" X 27 1/8" X 1" (26 mm) CS: 2" X 28 1/8" ENTRADA: 1 3/8" CI: 2" X 28 1/8" SALIDA: 1 3/8" EDA: 11 7/8" EDAM: NO NOTAS: Puede usar ST: 2181</p> <p>056</p>	<p>2054 DPI NISSAN / INFINITI</p>  <p>Conexiones de espiga</p> <p>Q45 96-01 V8 4.1/4.5</p> <p>PANAL: 17 11/16" X 27 5/16" X 1 5/16" CS: 1 7/8" X 28 1/16" ENTRADA: 1 3/8" CI: 2 1/4" X 28 1/16" SALIDA: 1 3/8" EDA: SI Concentrico EDAM: NO</p> <p>057</p>
<p>2055 DPI NISSAN/INFINITI</p>  <p>Tomas lado copiloto</p> <p>Tomas encontradas usar DPI 2459</p> <p>Qx4 97-00/PATHFINDER 96-00 V6 3.3</p> <p>PANAL: 19 3/4" X 27 1/4" X 2" (49 mm) CS: 1 7/8" X 28" ENTRADA: 1 3/8" CI: 2 1/4" X 28" SALIDA: 1 3/8" EDA: SI EDAM: NO NOTAS: Panel delgado usar 2075</p> <p>058</p>	<p>2075 DPI NISSAN</p>  <p>Tomas lado copiloto</p> <p>Tomas encontradas usar DPI 2459</p> <p>PATHFINDER 96-00 V6 3.3</p> <p>PANAL: 19 3/4" X 27 1/4" X 1" (26 mm) CS: 1 3/8" X 26 1/4" ENTRADA: 1 3/8" CI: 1 7/8" X 26 1/4" SALIDA: 1 3/8" EDA: 14 3/4" EDAM: NO NOTAS: Puede usar 2 Lineas 2055</p> <p>059</p>	<p>2150 DPI NISSAN</p>  <p>Toma hacia un lado</p> <p>Enfriador 11 13/16"</p> <p>ALTIMA 00-01 L4 2.4</p> <p>PANAL: 14 7/8" X 27 3/16" X 5/8" (16 mm) CS: 1 15/16" X 28 1/8" ENTRADA: 1 3/8" CI: 1 15/16" X 28 1/8" SALIDA 1 1/4" EDA: 11 13/16" EDAM: NO NOTAS: Panel delgado</p> <p>060</p>
<p>2151 DPI NISSAN</p>  <p>Tomas lado copiloto</p> <p>Sin enfriador</p> <p>FRONTIER/XTERRA 98-04/00-04 L4 2.4 V6 3.3</p> <p>PANAL: 17 11/16" X 28 1/8" X 1" (26 mm) CS: 1 7/8" X 28 1/8" ENTRADA: 1 3/8" CI: 2 1/4" X 28 1/16" SALIDA: 1 3/8" EDA: NO EDAM: NO</p> <p>061</p>	<p>2328 DPI NISSAN</p>  <p>Gollete al centro</p> <p>Tomas encontradas de 1 3/8"</p> <p>SENTRA 00-01 L4 2.0</p> <p>PANAL: 14 3/16" X 27 15/16" X 5/8" (16 mm) CS: 1 7/16" X 28 1/16" ENTRADA: 1 3/8" CI: 1 7/8" X 28 1/16" SALIDA: 1 3/8" EDA: 11 13/16" EDAM: NO</p> <p>062</p>	<p>2333 DPI NISSAN</p>  <p>Toma hacia lado derecho</p> <p>Enfriador 13 3/4"</p> <p>ALTIMA 00-01 L4 2.4</p> <p>PANAL: 14 7/8" X 27 3/16" X 5/8" (16 mm) CS: 1 15/16" X 28 3/16" ENTRADA: 1 3/8" CI: 1 5/16" X 28 1/16" SALIDA: 1 3/8" EDA: 13 3/4" EDAM: NO</p> <p>063</p>

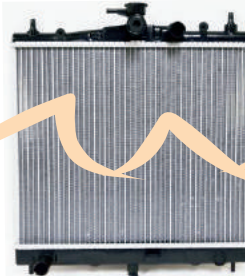
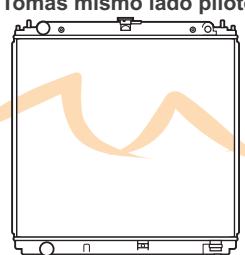
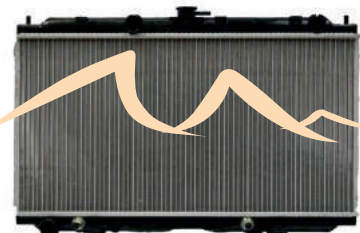
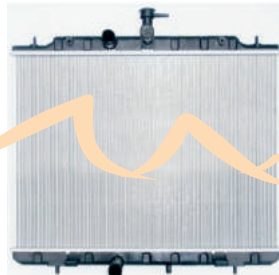
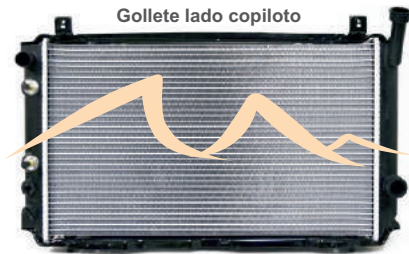
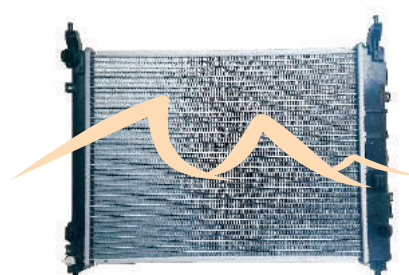
<p>2415 DPI NISSAN</p>  <p>Tomas al mismo lado usar A2414-28C</p> <p>MAXIMA 04-06/ALTIMA 02-06 V6 3.5</p> <p>PANAL: 15 3/4" X 29 1/4" X 5/8" (16 mm) CS: 1 27/32" X 29 27/32" ENTRADA: 1 3/8" CI: 1 27/32" X 29 27/32" SALIDA: 1 3/8" EDA: 13 3/4" EDAM: NO CONDENSADOR: AC3057</p> <p style="text-align: right;">064</p>	<p>2459 DPI NISSAN/INFINITI</p>  <p>Tomas encontradas</p> <p>Tomas mismo lado usar DPI 2075</p> <p>PATHFINDER 01-04/QX4 01-03 V6 3.5</p> <p>6104 PHAR</p> <p>PANAL: 19 3/4" X 27 3/16" X 1" (26 mm) CS: 1 15/16" X 28 1/8" ENTRADA: 1 3/8" CI: 2 7/16" X 28 1/8" SALIDA: 1 3/8" EDA: 14 3/4" Concéntrico EDAM: NO</p> <p style="text-align: right;">065</p>	<p>2576 DPI NISSAN</p>  <p>Gollete escuadra lado del piloto</p> <p>Con enfriador</p> <p>A/T 350Z 03-06 V6 3.5</p> <p>PANAL: 15 3/4" X 28 11/16" X 5/8" (16 mm) CS: 1 7/8" X 29 3/16" ENTRADA: 1 13/32" CI: 1 7/8" X 29 3/16" SALIDA: 1 13/32" EDA: 14 3/4" EDAM: NO</p> <p style="text-align: right;">066</p>
<p>2577 DPI NISSAN</p>  <p>Gollete escuadra lado del piloto</p> <p>Sin enfriador</p> <p>M/T 350Z 03-06 V6 3.5</p> <p>PANAL: 15 3/4" X 28 11/16" X 5/8" (16 mm) CS: 1 7/8" X 29 3/16" ENTRADA: 1 13/32" CI: 1 7/8" X 29 3/16" SALIDA: 1 13/32" EDA: NO EDAM: NO NOTAS: ST.</p> <p style="text-align: right;">067</p>	<p>2693 DPI NISSAN</p>  <p>Tomas encontradas</p> <p>MAXIMA 04-06 V6 3.5</p> <p>PANAL: 15 3/4" X 28 11/16" X 5/8" (16 mm) CS: 1 7/8" X 29 3/16" ENTRADA: 1 13/32" CI: 1 7/8" X 29 3/16" SALIDA: 1 13/32" EDA: 13 3/4" EDAM: NO</p> <p style="text-align: right;">068</p>	<p>2807 DPI NISSAN/SUZUKI</p>  <p>Tomas encontradas</p> <p>FRONTIER/EQUATOR 09-12/PATHFINDER/XTERRA 05-13 V6 4.0 V8 5.6</p> <p>PANAL: 23 5/8" X 27 3/16" X 1 1/4" (32 mm) CS: 2 1/4" X 28 1/16" ENTRADA: 1 3/8" CI: 2 1/4" X 28 1/16" SALIDA: 1 3/8" EDA: SI EDAM: NO CONDENSADOR: AC3239/AC3331</p> <p style="text-align: right;">069</p>
<p>2808 DPI NISSAN/SUZUKI</p>  <p>Tomas mismo lado</p> <p>FRONTIER 05-13/EQUATOR 09-12 A/T L4 2.5</p> <p>PANAL: 23 5/8" X 27 3/16" X 5/8" (16 mm) CS: 2 1/4" X 28 1/16" ENTRADA: 1 3/8" CI: 2 1/4" X 28 1/16" SALIDA: 1 3/8" EDA: SI EDAM: NO CONDENSADOR: AC3331</p> <p style="text-align: right;">070</p>	<p>2981 DPI NISSAN</p>  <p>Toma Superior al centro</p> <p>Enfriador largo</p> <p>VERSA 07-11 L4 1.6/1.8</p> <p>PANAL: 14 15/16" X 23 1/8" X 11/16" CS: 1 7/16" X 25 1/16" ENTRADA: 1 3/8" CI: 2" X 25 1/16" SALIDA: 1 3/8" EDA: SI Concéntrico 11 13/16" EDAM: NO</p> <p style="text-align: right;">071</p>	<p>2988 DPI NISSAN</p>  <p>Sin gollete</p> <p>ALTIMA 07-13 / MAXIMA 09-13 L4 2.5</p> <p>DPI 2988</p> <p>PANAL: 26 3/8" X 15 5/8" X 11/16" CS: 2" X 17 5/16" ENTRADA: 1 3/8" CI: 2" X 17 5/16" SALIDA: 1 3/8" EDA: SI 752988-M</p> <p>CONDENSADOR: AC3639</p> <p style="text-align: right;">072</p>

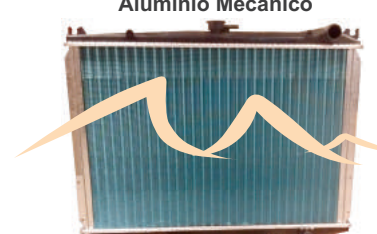
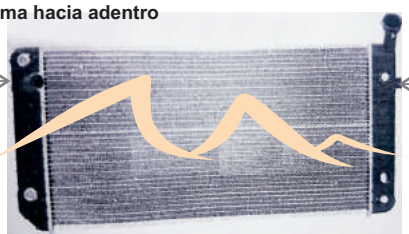
<p>13005 DPI NISSAN</p>  <p>Gollete lado copiloto Tomas encontradas</p> <p>MAXIMA 07-08 V6 3.5</p> <p>PANAL: 15 3/4" X 28 11/16" X 5/8" (16 mm) CS: 1 7/8" X 29 13/16" ENTRADA: 1 5/16" CI: 1 7/8" X 29 13/16" SALIDA: 1 5/16" EDA: SI</p> <p>CONDENSADOR: AC3057 073</p>	<p>13039 DPI NISSAN</p>  <p>Sin gollete</p> <p>QUEST 11-13/MURANO 2009 V6 3.5</p> <p>PANAL: 26 1/2" X 17 3/4" X 1" (26mm) CS: 19" X 1 3/4" ENTRADA: 1 3/8" CI: 19" X 1 3/4" SALIDA: 1 3/8" EDA: SI</p> <p>CONDENSADOR: AC3774 074</p>	<p>13047 DPI NISSAN</p>  <p>Tomas mismo lado</p> <p>M/T ROGUE 08-13 L4 2.5</p> <p>PANAL: 17 11/16" X 27 1/16" X 5/8" CS: 1 13/16" X 28 1/16" ENTRADA: 1 3/8" CI: 1 13/16" X 28 1/16" SALIDA: 1 3/8" EDA: NO</p> <p>CONDENSADOR: AC3680 075</p>
<p>13260 DPI NISSAN</p>  <p>VERSAT/IIIDA 12-15 L4 1.6/1.8 AUT</p> <p>PANAL: 20" X 16 1/2" X 5/8" (16) CS: 1 13/16" X 17 9/16" ENTRADA: 1 1/8" CI: 1 13/16" X 17 9/16" SALIDA: 1 1/8" EDA: SI CONCENTRICO</p> <p>076</p>	<p>13261 DPI NISSAN</p>  <p>VERSAT/IIIDA/NOTE 12-15 L4 1.6/1.8 STD</p> <p>PANAL: 20 1/16" X 16 1/2" X 5/8" (16 MM) CS: 1 13/16" X 17 9/16" ENTRADA: 1 1/8" CI: 1 13/16" X 17 9/16" SALIDA: 1 1/8" EDA: NO</p> <p>077</p>	<p>13264 DPI NISSAN</p>  <p>Tomas hacia dentro de panel</p> <p>JUKE 11-15 L4 1.6</p> <p>PANAL: 19 7/8" X 16 7/8" X 1" CAB. SUP.: 1 13/16" X 17 5/8" CAB. INF.: 1 13/16" X 17 5/8" Enfriador: NO</p> <p>TOMAS: ENTRADA: 1 7/16" SALIDA: 1 7/16"</p> <p>CONDENSADOR: AC3968 078</p>
<p>13365 DPI NISSAN</p>  <p>Toma curva hacia panel</p> <p>SENTRA 13-16 L4 1.8</p> <p>PANAL: 20 1/16" X 16 1/16" X 5/8" CAB. SUP.: 2" X 17" CAB. INF.: 2" X 17" Enfriador: NO</p> <p>TOMAS: ENTRADA: 1 3/8" SALIDA: 1 3/8"</p> <p>079</p>	<p>115433-16N DPI NISSAN</p>  <p>D23 NP 300 NAVARA 15-17 GASOLINA 2.5 / DIESEL 2.3</p> <p>PANAL: 28 7/16" X 19 1/4" X 5/8" CS: 1 7/8" X 20 1/4" ENTRADA: 1 3/8" CI: 1 7/8" X 20 1/4" SALIDA: 1 3/8" EDA: NO EDAM:</p> <p>080</p>	<p>LHRP173 NISSAN</p>  <p>Toma y gollete al centro</p> <p>TIIDA 07-13 L4 1.6/1.8</p> <p>PANAL: 15" X 23 15/16" X 5/8" (16 mm) CS: 24 5/8" X 1 7/16" ENTRADA: 1 3/8" CI: 24 5/8" X 1 7/16" SALIDA: 1 3/8" EDA: SI Concéntrico 8" EDAM:</p> <p>081</p>

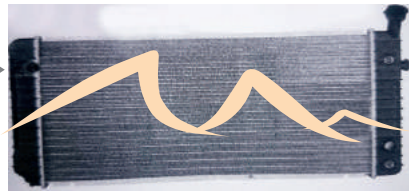
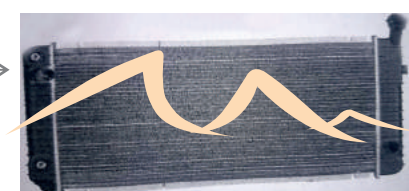
<p>LHRP287 NISSAN</p>  <p>MICRA/K12 05-07 L4 1.0/1.2/1.4</p> <p>PANAL: 14 5/16" X 17 5/8" X 5/8" CS: 1 13/32" X 18 1/2" CI: 1 13/16" X 18 1/2" EDA: NO EDAM: NO</p> <p>ENTRADA: 1 1/8" SALIDA: 1 1/8"</p> <p>082</p>	<p>LHRP305-2R NISSAN</p> <p>Tomas mismo lado piloto</p>  <p>PATHFINDER 05-13 IMPORTACION M/T L4 2.5</p> <p>PANAL: 23 5/8" X 27 3/16" X 1" (26 mm) CS: 28 3/32" X 1 7/8" CI: 28 3/32" X 1 7/8" EDA: NO EDAM:</p> <p>ENTRADA: 1 3/8" SALIDA: 1 3/8"</p> <p>083</p>	<p>LHRP444 NISSAN</p> <p>Gollete al centro</p>  <p>ALMERA 00-09 1.8/2.0 16V.</p> <p>PANAL: 14 3/16" X 27 1/2" X 5/8" (16mm) CS: 1 13/16" X 28 1/4" CI: 13/16" X 28 1/4" EDA: SI</p> <p>ENTRADA: 1 3/8" SALIDA: 1 3/8"</p> <p>084</p>
<p>LHRP527 NISSAN</p>  <p>X-TRAIL 08-11 L4 2.0 / V6 2.5</p> <p>PANAL: 17 3/4" X 27 1/16" X 5/8" CAB. SUP.: 1 7/16" X 28 1/16" CAB. INF.: 1 7/16" X 28 1/16" Enfriador: NO</p> <p>TOMAS: ENTRADA: 1 7/16" SALIDA: 1 7/16"</p> <p>085</p>	<p>LHRP810 NISSAN</p> <p>Gollete lado copiloto</p>  <p>TSURU II 87-91 L4 1.6</p> <p>PANAL: 23 1/8" X 13 11/16" X 5/8" CS: 2 1/16" X 14 5/16" CI: 2 1/16" X 14 5/16" EDA: SI Concentrico EDAM: NO</p> <p>ENTRADA: 1 1/8" SALIDA: 1 1/8"</p> <p>086</p>	<p>LHRP-1065-16 NISSAN</p>  <p>TIDDA/VERSA/NOTE 12-15 L4 1.6/1.8</p> <p>PANAL: 20 1/16" X 15 1/4" X 5/8" CAB. SUP.: 1 13/16" X 16 3/8" CAB. INF.: 1 13/16" X 16 3/8" Enfriador: NO</p> <p>TOMAS: ENTRADA: 1 1/8" SALIDA: 1 1/8"</p> <p>087</p>
<p>M0314-26C NISSAN</p> <p>Aluminio Mecánico</p>  <p>Tomas lineales mismo lado copiloto</p> <p>PICK UP D21 86-94/PATHFINDER 87-95/PICK UP 95-04 5569 PHAR L4 2.4 / V6 3.0</p> <p>PANAL: 16 7/8" X 24 7/8" X 1" CS: 1 7/8" X 26 1/4" CI: 1 7/8" X 26 1/4"</p> <p>ENTRADA: 1 3/8" SALIDA: 1 3/8"</p> <p>ENFRIADOR: SI</p> <p>088</p>	<p>M0314-26N NISSAN</p> <p>Aluminio Mecánico</p>  <p>Tomas lineales mismo lado copiloto</p> <p>PICK UP D21 86-94/PATHFINDER 87-95/PICK UP 95-04 5569 PHAR L4 2.4 / V6 3.0</p> <p>PANAL: 16 7/8" X 24 7/8" X 1" CS: 1 7/8" X 26 1/4" CI: 1 7/8" X 26 1/4"</p> <p>ENTRADA: 1 3/8" SALIDA: 1 3/8"</p> <p>ENFRIADOR: NO</p> <p>089</p>	<p>A1051-28C BUICK/CHEVROLET PONTIAC/OLDSMOBILE</p> <p>Toma hacia adentro</p>  <p>Base hacia polvera</p> <p>REGAL CUSTOM 90-93/ LUMINA 91-93/ GRAND PRIX 91-93/CUTLASS 91-93 DPI 1051 V6 3.1/3.4/3.8</p> <p>PANAL: 34 3/4" X 19 1/16" X 5" CAB. SUP.: 16 3/8" X 2 5/16" CAB. INF.: 16 3/8" X 2 5/16"</p> <p>TOMAS: ENTRADA: 1 5/16" SALIDA: 1 5/16"</p> <p>ENFRIADOR: SI DOBLE</p> <p>090</p>

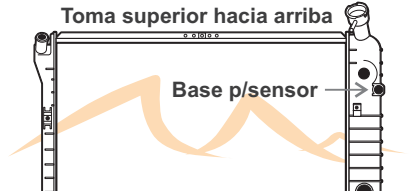
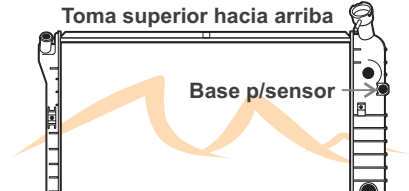
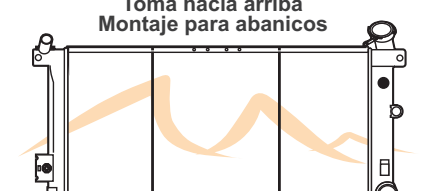
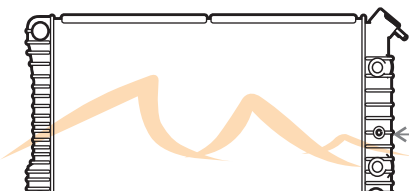
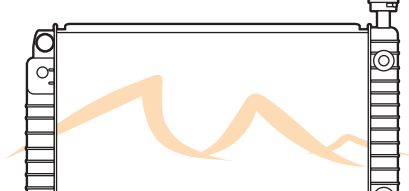
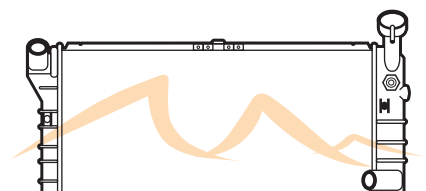
<p>A1206-28C BUICK/CHEVROLET PONTIAC/OLDSMOBILE</p> <p>Toma hacia adentro</p>  <p>Base sensor</p> <p>REGAL CUSTOM 90-93/ LUMINA 91-93/ GRAND PRIX 91-93/CUTLASS SUPREME 92</p> <p>DPI 1206 / PHAR 6009 V6 3.1</p> <p>PANAL: 34 3/4" X 19 1/16" X 5" CAB. SUP.: 16 3/8" X 2 5/16" CAB. INF.: 16 3/8" X 2 5/16"</p> <p>TOMAS: ENTRADA: 1 5/16" SALIDA: 1 5/16"</p> <p>ENFRIADOR: SI</p> <p>091</p>	<p>A1216-28C CHEVROLET PONTIAC/OLDSMOBILE</p> <p>Toma hacia adentro</p>  <p>Base sensor</p> <p>LUMINA 91-93/GRAND PRIX 91-93/CUTLASS SUPREME 92</p> <p>DPI 1216 V6 3.1/3.4</p> <p>PANAL: 34 3/4" X 19 1/16" X 5" CAB. SUP.: 16 3/8" X 2 5/16" CAB. INF.: 16 3/8" X 2 5/16"</p> <p>TOMAS: ENTRADA: 1 5/16" SALIDA: 1 5/16"</p> <p>ENFRIADOR: SI</p> <p>092</p>	<p>A1344-28C OLDSMOBILE / PONTIAC BUICK / CHEVROLET</p> <p>Enfriador lado piloto</p>  <p>Toma curva hacia adentro 90°</p> <p>SKYLARK/BERETTA/CORSICA 92-93 ACHIEVA/GRAND AM 92-93</p> <p>DPI 1344 / PHAR 2276 L4 2.2/2.3 V6 3.1</p> <p>PANAL: 25 15/16" X 15 1/8" X 1 1/8" CS: 16 7/16" X 2 5/16" CI: 16 7/16" X 2 5/16"</p> <p>ENTRADA: 1 5/16" SALIDA: 1 5/16"</p> <p>ENFRIADOR: SI 75999-M 03/15</p> <p>093</p>
<p>A1888-28P3 OLDSMOBILE/CHEVROLET/GMC</p> <p>Toma superior hacia arriba</p>  <p>Base p/sensor</p> <p>GRAND PRIX/VENTURE/SILHOUETTE 97-00</p> <p>DPI 1889 / 6109 PHAR V6 3.1/3.4/3.8</p> <p>PANAL: 30 1/2" X 15 5/16" X 1 1/8" CS: 2 7/16" X 16 9/16" CI: 2 7/16" X 16 9/16"</p> <p>ENTRADA: 1 5/16" SALIDA: 1 5/16"</p> <p>ENFRIADOR: SI</p> <p>094</p>	<p>A1889-13P3 OLDSMOBILE/CHEVROLET/GMC</p> <p>Toma superior hacia arriba</p>  <p>Base p/sensor</p> <p>TRANSPORT/VENTURE/SILHOUETTE 97-00</p> <p>DPI 1889 / 6109 PHAR V6 3.1/3.4/3.8</p> <p>PANAL: 30 1/2" X 14 7/8" X 1/2" CS: 2 7/16" X 16 9/16" CI: 2 7/16" X 16 9/16"</p> <p>ENTRADA: 1 5/16" SALIDA: 1 5/16"</p> <p>ENFRIADOR: SI</p> <p>095</p>	<p>A2728-13C OLDSMOBILE/GMC CHEVROLET/PONTIAC</p> <p>Toma hacia arriba Montaje para abanicos</p>  <p>AZTEK/VENTURE 3.4/IMPALA 03-05</p> <p>7033 PHAR / DPI 2728 V6 3.4/3.5</p> <p>PANAL: 30 1/2" X 15" X 1/2" CS: 2 1/2" X 15 3/8" CI: 2 1/2" X 15 3/8"</p> <p>ENTRADA: 1 5/16" SALIDA: 1 5/16"</p> <p>ENFRIADOR: SI CONDENSADOR: AC3050</p> <p>096</p>
<p>1202 DPI OLDSMOBILE/BUICK</p>  <p>Base para sensor</p> <p>88/BONEVILLE/REGENCY 91-99</p> <p>2415 PHAR V6 3.8</p> <p>PANAL: 30 1/2" X 17 1/4" X 1" (26 mm) CS: 2 1/2" X 18 3/4" CI: 2 1/2" X 18 3/4"</p> <p>EDA: 11 1/2" 4 PLACAS EDAM: NO</p> <p>NOTAS: Substituye 1684 WO/LCI PLUG</p> <p>097</p>	<p>1476 DPI OLDSMOBILE/CHEVROLET/GM</p>  <p>Base para sensor</p> <p>TRANSPORT/LUMINA APV 92-95</p> <p>1476 PHAR V6 3.8</p> <p>PANAL: 28 1/4" X 17 1/4" X 1 3/8" CS: 2 1/2" X 18 3/4" CI: 2 1/2" X 18 3/4"</p> <p>EDA: 11 1/2" 4 PLACAS EDAM: 11 1/2" 4 PLACAS</p> <p>ENTRADA: 1 1/4" SALIDA: 1 1/4"</p> <p>098</p>	<p>1518 DPI OLDSMOBILE/CHEVROLET/GM</p>  <p>Base para sensor</p> <p>LUMINA 94-97</p> <p>6019 PHAR V6 3.8</p> <p>PANAL: 30 1/2" X 15 X 1" CS: 2 1/2" X 16 5/8" CI: 2 1/2" X 16 5/8"</p> <p>EDA: 11 1/2" 4 PLACAS EDAM: NO</p> <p>ENTRADA: 1 5/16" SALIDA: 1 5/16"</p> <p>099</p>

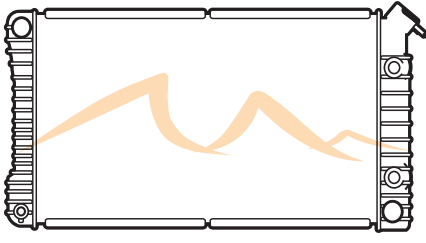
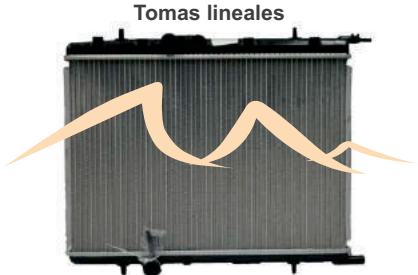
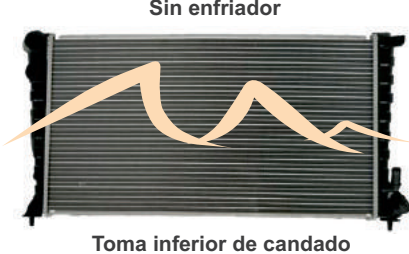
1684 DPI OLDSMOBILE/BUICK	LHRP099 PEUGEOT	LHRP184 PEUGEOT
		
LESABRE/REGENCY 96-99/97-98 V6 3.8	PARTNER 2004/307 02-03 MT L4 2.0	306 98-12 MT/AT L4 1.8/1.9/2.0
PANAL: 30 1/2" X 17 3/8" X 1" (26mm) CS: 2 1/4" X 18 5/8" ENTRADA: 1 5/16" CI: 2 1/4" X 18 5/8" SALIDA: 1 9/16" EDA: 11 1/2" 4 PLACAS EDAM: NO	PANAL: 14 7/8" X 21 9/16" X 1" (26mm) CS: 1 11/16" X 22 3/16" ENTRADA: 1 1/4" CI: 1 11/16" X 22 3/16" SALIDA: 1 1/4" EDA: NO	PANAL: 26 1/4" X 14 1/8" X 1 1/4" (32mm) CS: 1 7/8" X 14 15/16" ENTRADA: 1" CI: 1 7/8" X 14 15/16" SALIDA: 1 7/8" EDA: NO
100	101	102

LHRP291 CITROEN/PEUGEOT	LHRP451 PEUGEOT	LHRP480 PEUGEOT
		
206/C4 2004 MT L4 1.6	306 98-02 L4 1.6	207/307/PARTNER 98-00 16V / L4 1.6/2.0
PANAL: 14 7/8" X 21 9/16" X 1" (26mm) CS: 1 11/16" X 22 3/16" ENTRADA: 1 1/4" CI: 1 11/16" X 22 3/16" SALIDA: 1 1/4" EDA: NO	PANAL: 23 13/16" X 14 3/32" X 1 11/16" CS: 2 3/8" X 14 15/16" ENTRADA: 1 3/4" CI: 2 3/8" X 14 15/16" SALIDA: 1 3/4" EDA: NO EDAM: NO	PANAL: 14 7/8" X 21 9/16" X 1" CS: 1 11/16" X 22 3/16" ENTRADA: 1 1/4" CI: 1 11/16" X 22 3/16" SALIDA: 1 1/4" EDA: NO EDAM: NO
103	104	105

PG-009 **PEUGEOT**



206 98-04
L4 1.1/1.4/1.6

PANAL: 14 7/8" X 21 1/2" X 1" (26mm)
CS: 1 13/16" X 22 3/8" ENTRADA: 1 1/4"
CI: 1 13/16" X 22 3/8" SALIDA: 1 1/4"
EDA: NO

106

My PHAR

www.phar.com.mx

**PRUEBA NUESTRA
VERSION IMPRESA
EN LINEA**



www.phar.com.mx



NOTAS

Large lined area for notes, with a decorative orange wave graphic at the bottom.

Radiadores

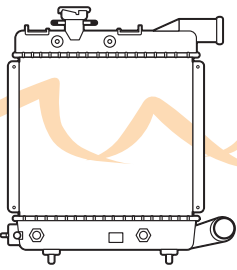
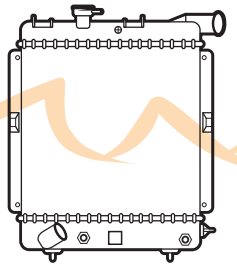
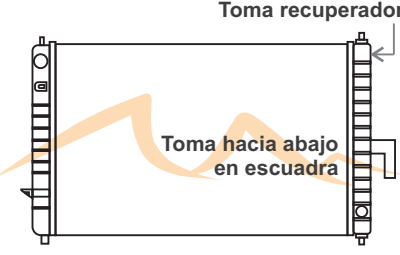
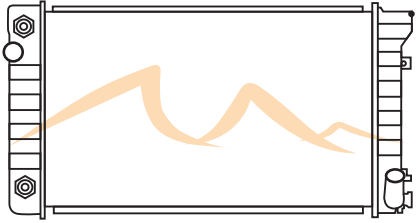
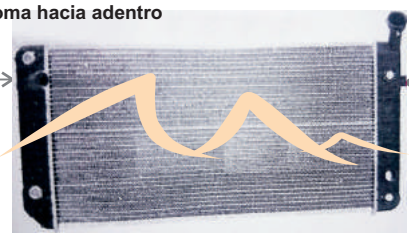
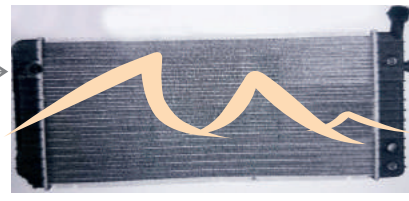
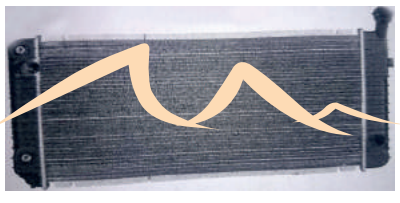
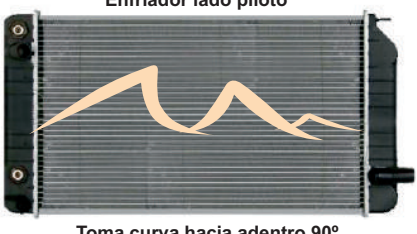

PHAR

- **PLYMOUTH**
- **PONTIAC**
- **PORSCHE**

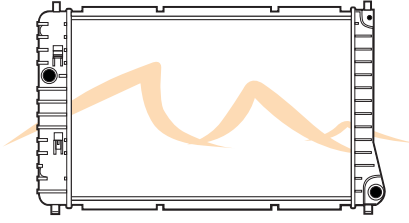
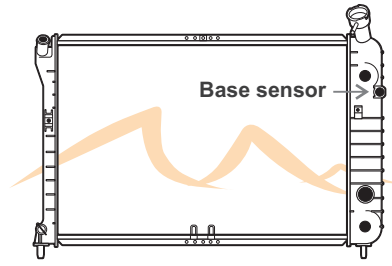
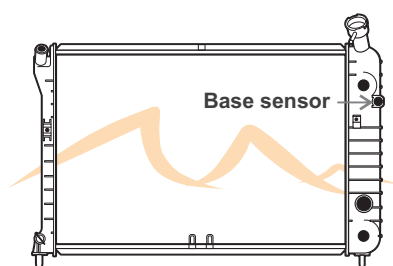
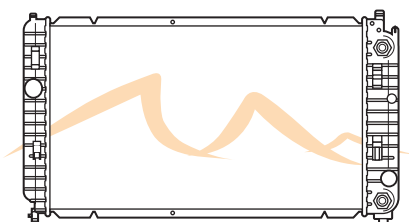
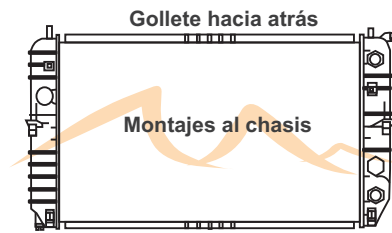
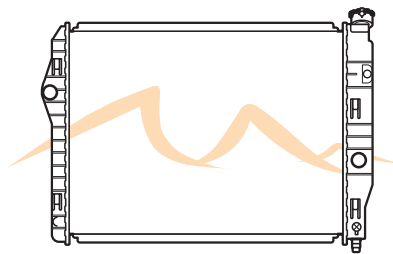
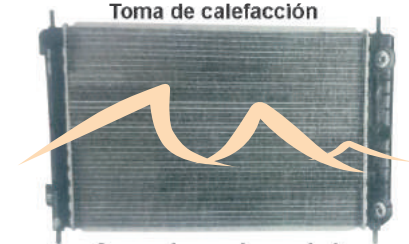
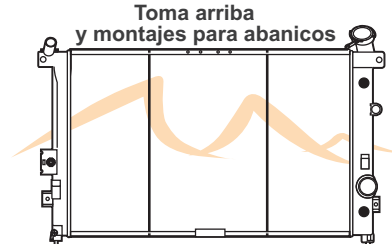
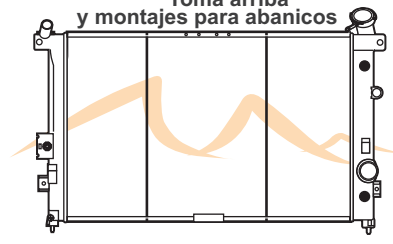
<p>A1125-28C PLYMOUTH/CHRYSLER/DODGE</p>  <p>VOYAGER 90-92/CARAVAN 90-92/TOWN COUNTRY 90-92 2227 PHAR / DPI 1125 L4 2.5 V6 3.0/3.3</p> <p>PANAL: 15 7/8" X 16 1/8" X 1 1/8" CS: 2 1/2" X 16 15/16" CI: 2 1/2" X 16 15/16" EDA: SI</p> <p>ENTRADA: 1 1/4" SALIDA: 1 1/4"</p> <p>001</p>	<p>A1387-44C PLYMOUTH/DODGE</p>  <p>CARAVAN 90-92/ VOYAGER 90-92</p> <p>6007 PHAR / DPI 1387 V6 3.0</p> <p>PANAL: 15 7/8" X 16" X 1 3/4" CS: 2 1/2" X 16 15/16" CI: 2 1/2" X 16 15/16" EDA: SI</p> <p>ENTRADA: 1 9/16" SALIDA: 1 1/4"</p> <p>NOTAS: Parte inferior de la manguera al lado del conductor</p> <p>002</p>	<p>A009-28N PONTIAC</p>  <p>Toma recuperador Toma hacia abajo en escuadra</p> <p>MATIZ 01-04</p> <p>7019 PHAR L4 1.0</p> <p>PANAL: 18" X 11 9/16" X 1 1/8" CS: 2" X 12 1/2" CI: 2" X 12 1/2"</p> <p>ENTRADA: 1 1/8" SALIDA: 1 1/8"</p> <p>ENFRIADOR: NO</p> <p>003</p>
<p>A0768-28C PONTIAC/CHEVROLET</p>  <p>CAVALIER 89-94 / SUNBIRD 91-94</p> <p>2208 PHAR / DPI 768 V6 2.8/3.1</p> <p>PANAL: 23 1/2" X 14" X 1 1/8" CS: 2 1/2" X 15 3/4" CI: 2 1/2" X 15 3/4"</p> <p>ENTRADA: 1 5/16" SALIDA: 1 5/16"</p> <p>ENFRIADOR: SI</p> <p>004</p>	<p>A1051-28C BUICK/CHEVROLET PONTIAC/OLDSMOBILE</p>  <p>Toma hacia adentro Base hacia polvera</p> <p>REGAL CUSTOM 90-93/ LUMINA 91-93/ GRAND PRIX 91-93/CUTLASS 91-93</p> <p>DPI 1051 V6 3.1/3.4/3.8</p> <p>PANAL: 34 3/4" X 19 1/16" X 5" CAB. SUP.: 16 3/8" X 2 5/16" CAB. INF.: 16 3/8" X 2 5/16"</p> <p>ENFRIADOR: SI DOBLE</p> <p>TOMAS: ENTRADA: 1 5/16" SALIDA: 1 5/16"</p> <p>005</p>	<p>A1206-28C BUICK/CHEVROLET PONTIAC/OLDSMOBILE</p>  <p>Toma hacia adentro Base sensor</p> <p>REGAL CUSTOM 90-93/ LUMINA 91-93/ GRAND PRIX 91-93/CUTLASS SUPREME 92</p> <p>DPI 1206 / PHAR 6009 V6 3.1</p> <p>PANAL: 34 3/4" X 19 1/16" X 5" CAB. SUP.: 16 3/8" X 2 5/16" CAB. INF.: 16 3/8" X 2 5/16"</p> <p>ENFRIADOR: SI</p> <p>TOMAS: ENTRADA: 1 5/16" SALIDA: 1 5/16"</p> <p>006</p>
<p>A1216-28C CHEVROLET PONTIAC/OLDSMOBILE</p>  <p>Toma hacia adentro Base sensor</p> <p>LUMINA 91-93/GRAND PRIX 91-93/CUTLASS SUPREME 92</p> <p>DPI 1216 V6 3.1/3.4</p> <p>PANAL: 34 3/4" X 19 1/16" X 5" CAB. SUP.: 16 3/8" X 2 5/16" CAB. INF.: 16 3/8" X 2 5/16"</p> <p>ENFRIADOR: SI</p> <p>TOMAS: ENTRADA: 1 5/16" SALIDA: 1 5/16"</p> <p>007</p>	<p>A1344-28C PONTIAC / OLDSMOBILE BUICK/CHEVROLET</p>  <p>Enfriador lado piloto Toma curva hacia adentro 90°</p> <p>SKYLARK/BERETTA/CORSICA 92-93 ACHIEVA/GRAND AM 92-93</p> <p>DPI 1344 / PHAR 2276 L4 2.2/2.3 V6 3.1</p> <p>PANAL: 25 15/16" X 15 1/8" X 1 1/8" CS: 16 7/16" X 2 5/16" CI: 16 7/16" X 2 5/16"</p> <p>ENFRIADOR: SI 75999-M 03/15</p> <p>ENTRADA: 1 5/16" SALIDA: 1 5/16"</p> <p>008</p>	<p>A1485-28C PONTIAC / GM</p>  <p>No incluye toma de calefacción y base p/sensor</p> <p>CAMARO/FIRE BIRD 93-02</p> <p>2417 PHAR V6 3.4/3.8</p> <p>PANAL: 24 3/4" X 17 1/4" X 1" (26 mm) CS: 2 1/2" X 18 3/4" CI: 2 1/2" X 18 3/4"</p> <p>ENTRADA: 1 5/16" SALIDA: 1 5/16"</p> <p>ENFRIADOR: SI</p> <p>009</p>

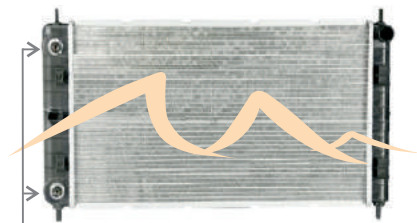
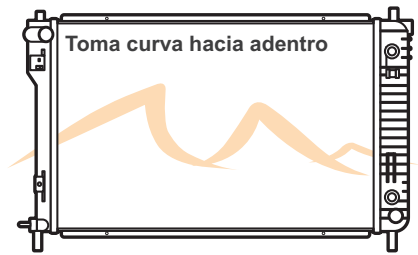
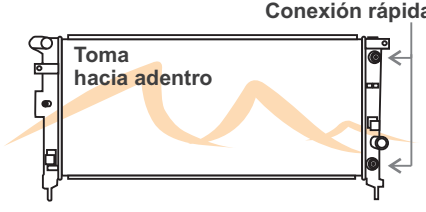
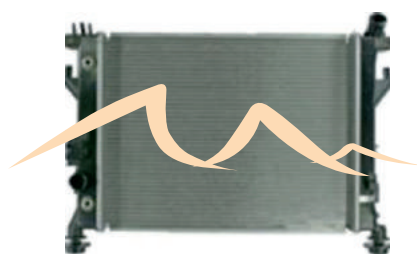
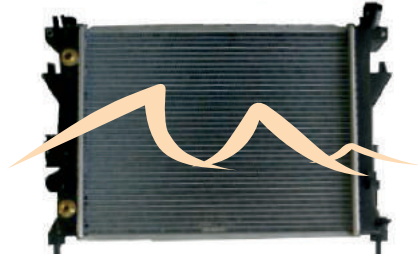
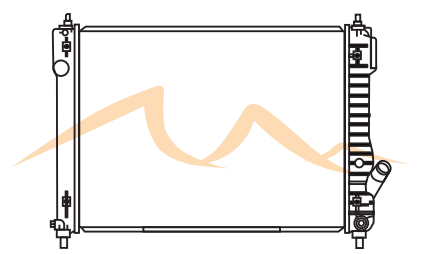
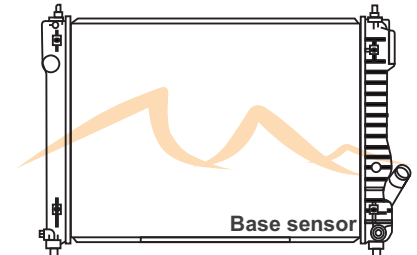
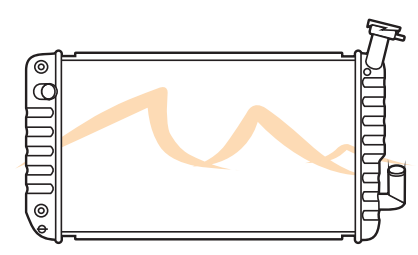
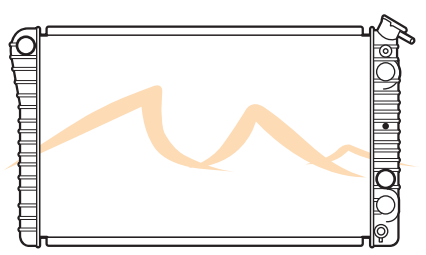
<p>A1687-28N PONTIAC/CHEVROLET</p>  <p>SUNFIRE 95-02/CAVALIER 95-03 2207 PHAR / DPI 1687 L4 2.2/2.3/2.4</p> <p>PANAL: 25 7/8" X 15" X 1 1/8" CS: 2 1/2" X 16 5/8" CI: 2 1/2" X 16 5/8"</p> <p>ENTRADA: 1 5/16" SALIDA: 1 5/16"</p> <p>ENFRIADOR: NO</p> <p style="text-align: right;">010</p>	<p>A1888-28P3 PONTIAC/OLDSMOBILE CHEVROLET/GMC</p>  <p>GRAND PRIX/VENTURE/SILHOUETTE 97-03 6109 PHAR / DPI 1888 V6 3.1/3.4/3.8</p> <p>PANAL: 30 1/2" X 15 5/16" X 1 1/8" CS: 2 7/16" X 16 9/16" CI: 2 7/16" X 16 9/16"</p> <p>ENTRADA: 1 5/16" SALIDA: 1 5/16"</p> <p>ENFRIADOR: SI</p> <p style="text-align: right;">011</p>	<p>A1889-13P3 PONTIAC/OLDSMOBILE CHEVROLET/GMC</p>  <p>GRAND PRIX/TRANSPORT/VENTURE/SILHOUETTE 97-00 6109 PHAR / DPI 1889 V6 3.1/3.4/3.8</p> <p>PANAL: 30 1/2" X 14 7/8" X 1/2" CS: 2 7/16" X 16 9/16" CI: 2 7/16" X 16 9/16"</p> <p>ENTRADA: 1 5/16" SALIDA: 1 5/16"</p> <p>ENFRIADOR: SI</p> <p style="text-align: right;">012</p>
<p>A2264-13C PONTIAC/CHEVROLET</p>  <p>GRAND AM 99-05/MALIBU 97-03 6018 PHAR / DPI 2264 L4 2.4 V6 3.1/3.4</p> <p>PANAL: 25 7/8" X 14 7/16" X 1/2" CS: 2 1/16" X 15 1/2" CI: 2 1/16" X 15 1/2"</p> <p>ENTRADA: 1 5/16" SALIDA: 1 5/16"</p> <p>ENFRIADOR: SI 3 PLACAS</p> <p style="text-align: right;">013</p>	<p>A2348-13C PONTIAC/BUICK</p>  <p>BONNEVILLE 00-05/ LASABRE 00-05 DPI 2438 V6 3.8</p> <p>PANAL: 30 5/8" X 15 1/8" X 1/2" CS: 2 3/8" X 17 7/16" CI: 2 3/8" X 17 7/16"</p> <p>ENTRADA: 1 5/16" SALIDA: 1 9/16"</p> <p>ENFRIADOR: SI</p> <p style="text-align: right;">014</p>	<p>A2365-28N PONTIAC/CHEVROLET</p>  <p>FIREBIRD 98-99/CAMARO</p> <p>PANAL: 24 13/16" X 17 1/2" X 1 1/8" CS: 2 7/16" X 18 3/4" CI: 2 7/16" X 18 3/4"</p> <p>ENTRADA: 1 5/16" SALIDA: 1 5/16"</p> <p>ENFRIADOR: NO</p> <p style="text-align: right;">015</p>
<p>A2727-28P3 CHEVROLET/PONTIAC/SATURN</p>  <p>MALIBU/G6/AURA 04-10 V6 3.5/3.9</p> <p>PANAL: 26 3/4" X 14 1/16" X 1 1/8" CAB. SUP.: 14 15/16" X 1 7/8" CAB. INF.: 14 15/16" X 1 7/8" ENF. TRANS.: 11 1/2"</p> <p>TOMAS: ENTRADA: 1 5/16" SALIDA: 1 5/16"</p> <p>CONDENSADOR: AC3279</p> <p style="text-align: right;">016</p>	<p>A2728-13C PONTIAC/CHEVROLET/BUICK</p>  <p>AZTEK 01-05/MONTANA/VENTURE/ RENDEZVOUS 02-07/UPLANDER 05-06 DPI 2728 / 7033 PHAR V6 3.4/3.5</p> <p>PANAL: 30 1/2" X 15" X 1/2" CS: 2 1/2" X 15 3/8" CI: 2 1/2" X 15 3/8"</p> <p>ENTRADA: 1 5/16" SALIDA: 1 5/16"</p> <p>ENFRIADOR: SI CONDENSADOR: AC3050</p> <p style="text-align: right;">017</p>	<p>A2728-28C PONTIAC/CHEVROLET/BUICK</p>  <p>MONTANA/RENDEZVOUS 02-07/ AZTEK 01-05/VENTURE/UPLANDER 05-06 DPI 2728 / 7033 PHAR V6 3.4/3.5</p> <p>PANAL: 30 1/2" X 15" X 1 1/8" CS: 2 1/2" X 15 3/8" CI: 2 1/2" X 15 3/8"</p> <p>ENTRADA: 1 5/16" SALIDA: 1 5/16"</p> <p>ENFRIADOR: SI CONDENSADOR: AC3050</p> <p style="text-align: right;">018</p>

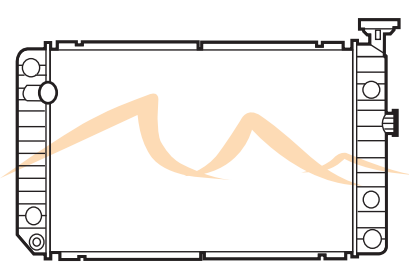
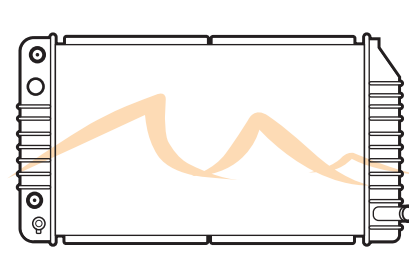
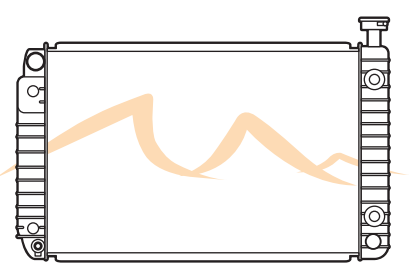
<p>A2864-28C CHEVROLET/PONTIAC/SATURN</p>  <p>Conexiones de candado</p> <p>MALIBU 08-12/ G6 06-10/AURA 07-09</p> <p>DPI 2864 L4 2.4/ V6 3.6</p> <p>PANAL: 26 3/4" X 14 5/8" X 1 1/8" CAB. SUP.: 14 7/8" X 1 7/8" CAB. INF.: 14 7/8" X 1 7/8"</p> <p>TOMAS: ENTRADA: 1 5/16" SALIDA: 1 5/16"</p> <p>ENFRIADOR: SI CONDENSADOR: AC3279</p> <p>019</p>	<p>A2879-28C PONTIAC/CHEVROLET/GMC</p>  <p>Toma curva hacia adentro</p> <p>EQUINOX 06-09 /TORRENT 06-09</p> <p>DPI 2879 L4 2.4/ V6 3.4</p> <p>PANAL: 26" X 16 1/4" X 1 1/8" CS: 2 3/8" X 17 1/16" CI: 2 3/8" X 17 1/16" EDA: SI</p> <p>ENTRADA: 1 5/16" SALIDA: 1 5/16"</p> <p>020</p>	<p>A2881-28C PONTIAC/CHEVROLET/GMC/BUICK</p>  <p>Conexión rápida</p> <p>Toma hacia adentro</p> <p>MONTANA 06-08/TERRAZA/UPLANDER 06-08</p> <p>DPI 2881 L4 2.4/ V6 3.9</p> <p>PANAL: 30 1/2" X 15" X 1 1/8" CS: 2 1/2" X 15 3/8" CI: 2 1/2" X 15 3/8"</p> <p>ENTRADA: 1 1/4" SALIDA: 1 1/4"</p> <p>ENFRIADOR: SI</p> <p>021</p>
<p>A2969-13C PONTIAC/SATURN</p>  <p>SOLSTICE 06-09/SKY 07-10</p> <p>DPI 2969 L4 2.0/2.4</p> <p>PANAL: 19 1/4" X 14 5/8" X 1/2" CS: 2 7/16" X 15 3/8" CI: 2 7/16" X 15 3/8"</p> <p>ENTRADA: 1 5/16" SALIDA: 1 5/16"</p> <p>ENFRIADOR: SI</p> <p>022</p>	<p>A13050-28C PONTIAC/SATURN</p>  <p>SOLSTICE 07-09/SKY 07-10</p> <p>DPI 13050 L4 2.0</p> <p>PANAL: 19 1/4" X 14 25/32" X 1 1/8" CAB. SUP.: 2 3/8" X 15 1/2" CAB. INF.: 2 3/8" X 15 1/2"</p> <p>TOMAS: ENTRADA: 1 5/16" SALIDA: 1 5/16"</p> <p>ENF. TRANS.: SI ENF. MOTOR: NO</p> <p>023</p>	<p>A13097-28C PONTIAC/CHEVROLET/GMC/SUZUKI</p>  <p>SWIFT+ 2009/AVEO 09-13/G3 09-10</p> <p>DPI 13097 L4 1.6</p> <p>PANAL: 23 1/2" X 16 3/8" X 1 1/8" CS: 1 13/16" X 17 1/4" CI: 1 13/16" X 17 1/4"</p> <p>ENTRADA: 1 5/16" SALIDA: 1 5/16"</p> <p>ENFRIADOR: SI</p> <p>024</p>
<p>A13097-28N PONTIAC/CHEVROLET/GMC/SUZUKI</p>  <p>Base sensor</p> <p>SWIFT 09/AVEO 09-13/G3 09</p> <p>DPI 13097 L4 1.6</p> <p>PANAL: 23 1/2" X 16 3/8" X 1 1/8" CS 1 13/16" X 17 1/4" : CI 1 13/16" X 17 1/4" :</p> <p>ENTRADA: 1 5/16" SALIDA: 1 5/16"</p> <p>ENFRIADOR: NO</p> <p>025</p>	<p>0333 DPI PONTIAC/CHEVROLET/GM</p>  <p>BERETTA/CORSICA 87-91/TEMPEST 87-89</p> <p>2405 PHAR L4 2.0 V6 2.8</p> <p>PANAL: 26" X 15" X 1 3/8" CS: 2 1/2" X 16 1/2" CI: 2 1/2" X 16 1/2" EDA: 11 1/2" EDAM: NO</p> <p>ENTRADA: 1 5/16" SALIDA: 1 5/16"</p> <p>026</p>	<p>0951 DPI PONTIAC/CHEVROLET/GM</p>  <p>CAMARO/P SERIES 26 A 82-92/89-90</p> <p>L4 2.5 V6 3.1/3.8 V8 5.0/5.7</p> <p>PANAL: 26 1/4" X 17 1/4" X 1 3/8" CS: 2 1/2" X 18 5/8" CI: 2 1/2" X 18 5/8" EDA: 11 1/2" EDAM: NO</p> <p>ENTRADA: 1 5/16" SALIDA: 1 9/16"</p> <p>027</p>

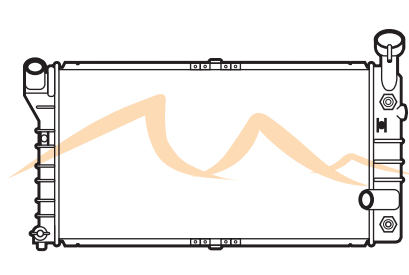
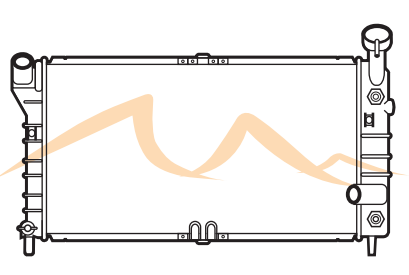
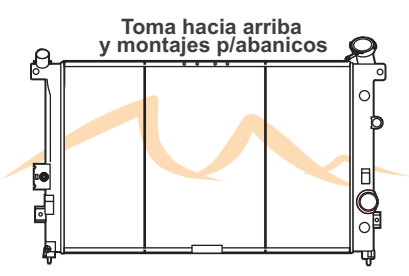
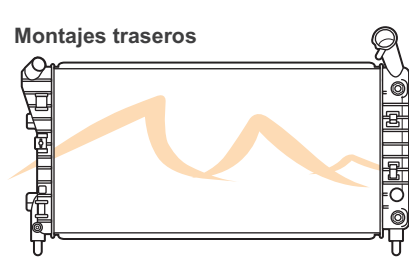
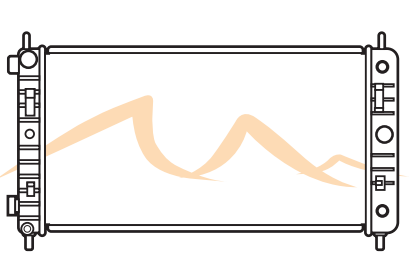
<p>1206 DPI PONTIAC/CHEVROLET/GM/BUICK</p>  <p>REGAL 91-93/GRAND PRIX/LUMINA/CUTLASS 91-93</p> <p>6009 PHAR V6 3.1</p> <p>PANAL: 28 1/4" X 15" X 1" (26 mm) CS: 2 1/2" X 16 1/2" ENTRADA: 1 5/16" CI: 2 1/2" X 16 1/2" SALIDA: 1 5/16" EDA: 11 1/2" 4 PLACAS EDAM: NO</p> <p>028</p>	<p>1344 DPI PONTIAC/CHEVROLET/GM/BUICK</p>  <p>BERETTA/CORSICA 92-94/SKYLARK/GRAND AM 92-93</p> <p>2276 PHAR L4 2.2/2.3 V6 3.1</p> <p>PANAL: 26" X 15" X 1 3/8" CS: 2 1/2" X 16 1/2" ENTRADA: 1 5/16" CI: 2 1/2" X 16 1/2" SALIDA: 1 5/16" EDA: 11 1/2" 3 PLACAS EDAM: NO NOTAS: Puede usar 1341</p> <p>029</p>	<p>1476 DPI PONTIAC/CHEVROLET/GM/OLDSMOBILE</p>  <p>SILHOUETTE 92-95/TRANS SPORT/LUMINA APV 92-95</p> <p>6009 PHAR V6 3.8</p> <p>PANAL: 28 1/4" X 17 1/4" X 1 3/8" CS: 2 1/2" X 18 3/4" ENTRADA: 1 1/4" CI: 2 1/2" X 18 3/4" SALIDA: 1 1/4" EDA: 11 1/2" 4 PLACAS EDAM: 11 1/2" 4 PLACAS</p> <p>030</p>
<p>1486 DPI PONTIAC/CHEVROLET/GM</p>  <p>CAMARO/TRANS AM 93-02</p> <p>V8 5.7</p> <p>PANAL: 28 1/4" X 17 1/4" X 1 3/8" CS: 2 3/8" X 18 5/8" ENTRADA: 1 1/4" CI: 2 3/8" X 18 5/8" SALIDA: 1 1/4" EDA: 11 1/2" EDAM: NO</p> <p>031</p>	<p>1519 DPI PONTIAC/CHEVROLET/GM/BUICK</p>  <p>REGAL 94-96/GRAND PRIX/LUMINA 94-01</p> <p>6019 PHAR V6 3.1/3.4/3.8</p> <p>PANAL: 30 1/2" X 15" X 5/8" (16 mm) CS: 2 1/2" X 16 5/8" ENTRADA: 1 5/16" CI: 2 1/2" X 16 5/8" SALIDA: 1 5/16" EDA: 11 1/2" 4 PLACAS EDAM: NO</p> <p>032</p>	<p>2251 DPI PONTIAC/CHEVROLET/GM</p>  <p>GRAND PRIX/LUMINA/MONTECARLO 96-01</p> <p>V6 3.1/3.4/3.8</p> <p>PANAL: 30 1/2" X 15 5/16" X 1" (26 mm) CS: 2 7/16" X 16 9/16" ENTRADA: 1 5/16" CI: 2 7/16" X 16 9/16" SALIDA: 1 5/16" EDA: 11 1/2" 4 PLACAS EDAM: NO</p> <p>033</p>
<p>2562 DPI PONTIAC/CHEVROLET/GM/BUICK</p>  <p>MONTANA/RENDEZVOUS 02-07/AZTEK/VENTURE 01-05</p> <p>7033 PHAR V6 3.4/3.8</p> <p>PANAL: 30 7/16" X 14 13/16" X 5/8" (16 mm) CS: 2 3/8" X 15 1/2" ENTRADA: 1 5/16" CI: 2 3/8" X 15 1/2" SALIDA: 1 5/16" EDA: 11" 8 PLACAS EDAM: NO CONDENSADOR: AC3050</p> <p>034</p>	<p>2710 DPI PONTIAC/CHEVROLET/GM/BUICK</p>  <p>GRAND PRIX 04-08/IMPALA/MONTECARLO 04-05</p> <p>7033 PHAR V6 3.4/3.8</p> <p>PANAL: 30 1/2" X 14 9/16" X 5/8" (16 mm) CS: 1 7/8" X 14 15/16" ENTRADA: 1 5/16" CI: 1 7/8" X 14 15/16" SALIDA: 1 5/16" EDA: SI EDAM: NO</p> <p>035</p>	<p>2727 DPI PONTIAC/CHEVROLET/GM</p>  <p>G6/MALIBU 05-06/04-06</p> <p>V6 3.5</p> <p>PANAL: 26 3/4" X 14 1/2" X 1" (26 mm) CS: 1 7/8" X 14 15/16" ENTRADA: 1 5/16" CI: 1 7/8" X 14 15/16" SALIDA: 1 3/8" EDA: SI EDAM: NO</p> <p>036</p>

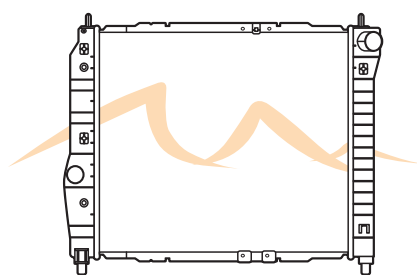
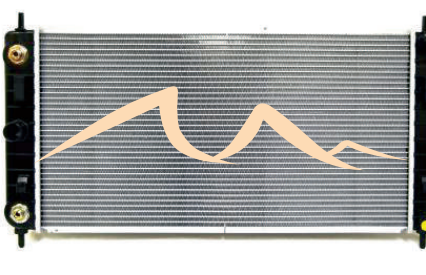
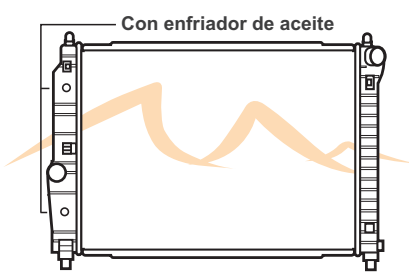
<p>2774 DPI PONTIAC/CHEVROLET/GM/SUZUKI</p>  <p>SWIFT+/G3 07-08/AVEO 04-08 L4 1.6</p> <p>PANAL: 18 7/8" X 16 3/8" X 5/8" (16 mm) CS: 1 13/16" X 17 5/16" ENTRADA: 1 5/16" CI: 1 13/16" X 17 5/16" SALIDA: 1 5/16" EDA: SI EDAM: NO</p> <p>037</p>	<p>2864 DPI CHEVROLET/PONTIAC SATURN</p>  <p>MALIBU 08-12/ G6 6-10/ AURA 07-09 L4 2.4 V6 3.6</p> <p>PANAL: 26 3/4" X 14 5/8" X 1 5/16" CS: 2 1/16" X 15 1/16" ENTRADA: 1 5/16" CI: 2 1/16" X 15 1/16" SALIDA: 1 5/16" EDA: SI 3 Placas EDAM: NO</p> <p>038</p>	<p>2873 DPI PONTIAC/CHEVROLET/GM/SUZUKI</p>  <p>Con enfriador de aceite</p> <p>SWIFT+/G3 07-08/AVEO 04-08 L4 1.4/1.5/1.6</p> <p>PANAL: 23 5/8" X 16 3/8" X 5/8" (16 mm) CS: 2" X 17 9/16" ENTRADA: 1 3/8" CI: 2" X 17 9/16" SALIDA: 1 3/8" EDA: 10" 3 PLACAS EDAM: NO</p> <p>039</p>
--	--	---

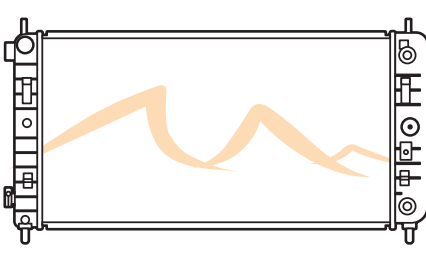
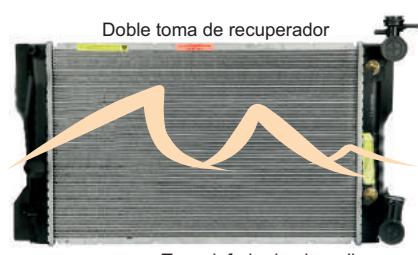
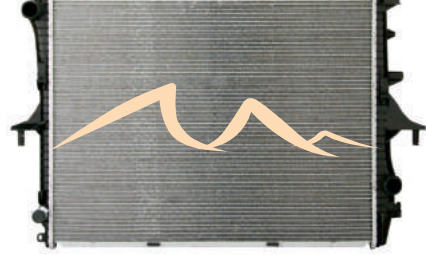
<p>2972 DPI PONTIAC/CHEVROLET/GM</p>  <p>MALIBU/G6 06-10</p> <p>PANAL: 26 3/4" X 14 1/4" X 1" (26 mm) CS: 1 7/8" X 14 15/16" ENTRADA: 1 5/16" CI: 1 7/8" X 14 15/16" SALIDA: 1 5/16" EDA: SI (3 PLACAS)</p> <p>040</p>	<p>13049 DPI TOYOTA/PONTIAC</p>  <p>Doble toma de recuperador</p> <p>Toma inferior hacia arriba</p> <p>COROLLA/MATRIX/VIBE 09-13 L4 2.4</p> <p>PANAL: 23 11/16" X 14 7/8" X 1" (26) CS: 1 7/8" X 15 3/4" ENTRADA: 1 3/8" CI: 1 7/8" X 15 3/4" SALIDA: 1 3/8" EDA: SI CONCENTRICO</p> <p>041</p>	<p>A2756-44N AUDI/PORSCHE/VW</p>  <p>Tomas de candado</p> <p>Q7 06-15/CAYENNE 03-10/TOUAREG 04-10 V6 3.0/3.2/3.6 / V8 4.1/4.2/4.5/4.8 / V10 4.9/5.0</p> <p>PANAL: 28" X 21 1/4" X 1 3/4" CAB. SUP.: 2 3/8" X 22 7/8" CAB. INF.: 2 3/8" X 22 7/8" ENF. TRANS.: NO</p> <p>TOMAS: ENTRADA: 1 1/2" SALIDA: 1 1/2"</p> <p>CONDENSADOR: AC3294</p> <p>042</p>
--	--	---

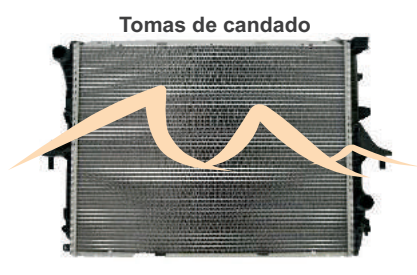
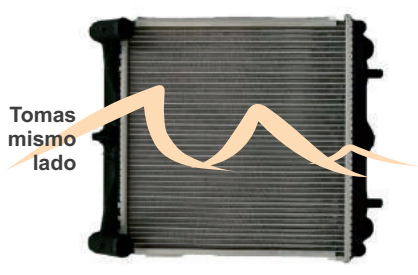
<p>LHRP429 PORSCHE/AUDI/VW</p>  <p>Tomas de candado</p> <p>CAYENNE 03-10/Q7 07-13/TOUREG 04-10 DPI 2756 V6 3.0/3.2/3.6 V8 4.2/4.5/4.8 V10 4.9/5.0</p> <p>PANAL: 27 15/16" X 21 9/16" X 1 11/16" CS: 2 9/32" X 22 13/16" ENTRADA: 1 3/4" CI: 2 9/32" X 22 13/16" SALIDA: 1 3/4" EDA: NO</p> <p>043</p>	<p>LHRP593 PORSCHE</p>  <p>Tomas mismo lado</p> <p>BOXSTER 00-06 / 911 99-04 DPI 2289 H6 2.7/3.2/3.4/3.6</p> <p>PANAL: 13 3/16" x 14 1/8" x 1 1/4" (32mm) CS: 1 13/16" X 14 11/16" ENTRADA: 1 5/16" CI: 1 13/16" X 14 11/16" SALIDA: 1 5/16" EDA: NO</p> <p>044</p>
--	---

PRUEBA NUESTRA VERSION IMPRESA EN LINEA







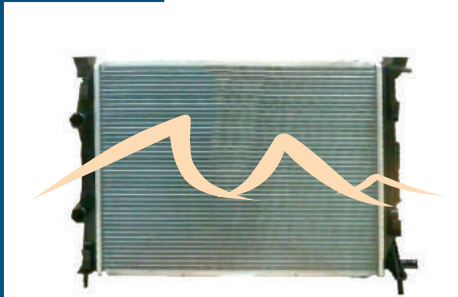
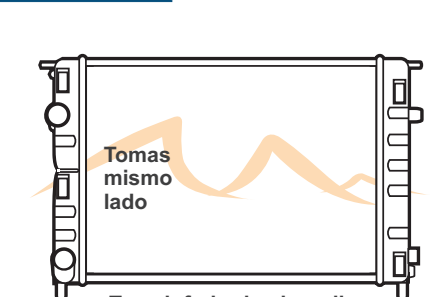
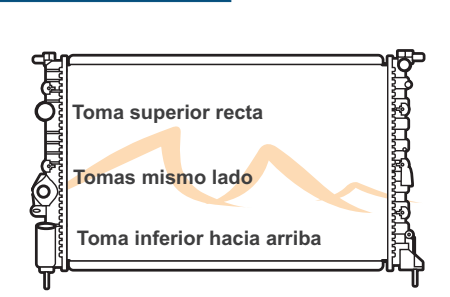
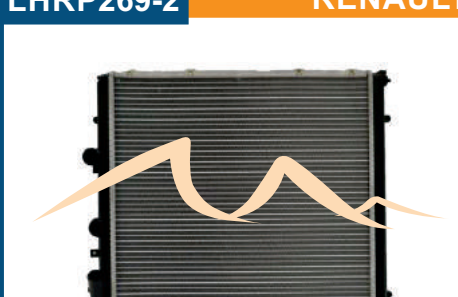
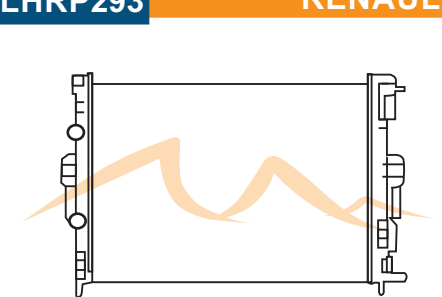

www.phar.com.mx

Radiadores

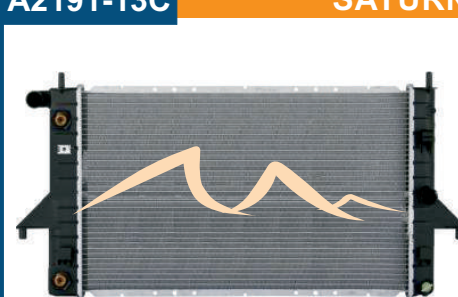
PHAR

- **RENAULT**
- **SATURN**
- **SCION**

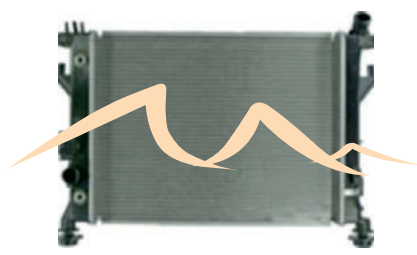
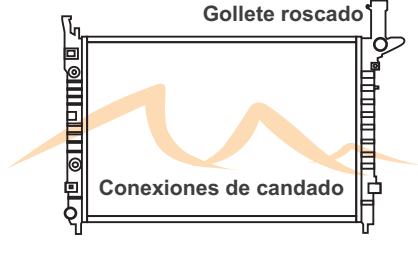
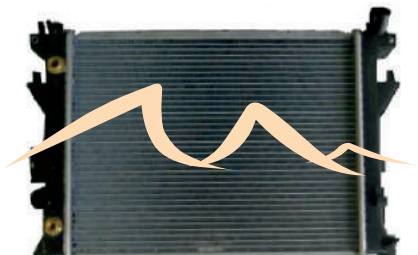
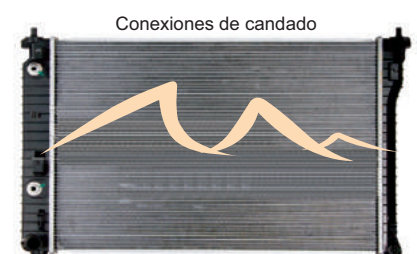
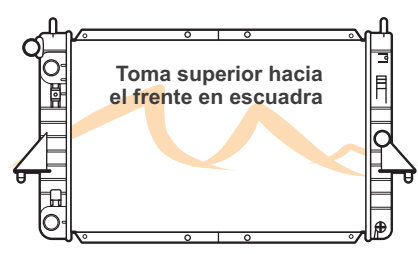
<p>A024-28N RENAULT</p>  <p>MEGANE 03-08 L4 1.5/1.8/2.0</p> <p>PANAL: 23 1/8" X 17 1/4" X 1 1/8" CS: 1 7/8" X 18 3/8" CI: 1 7/8" X 18 3/8" EDA: NO EDAM: NO</p> <p>ENTRADA: 1 1/4" SALIDA: 1 1/4"</p> <p>001</p>	<p>A6207-28N RENAULT/NISSAN</p>  <p>Tomas mismo lado</p> <p>Tomainferior hacia arriba</p> <p>CLIO/PLATINA 02-04 16V L4 1.4/1.6</p> <p>6207 PHAR</p> <p>PANAL: 18 7/8" X 15 5/16" X 1 1/8" CS: 1 5/8" X 16 1/4" CI: 1 5/8" X 16 1/4" MAQ. 110 1.6 LT. L4 16 VAL. ENFRIADOR: NO</p> <p>ENTRADA: 1 1/4" SALIDA: 1 1/4"</p> <p>002</p>	<p>LHRP110-16MT RENAULT</p>  <p>Toma superior recta</p> <p>Tomas mismo lado</p> <p>Toma inferior hacia arriba</p> <p>SCENIC 02-06/MEAGNE 02-06/CLIO II L4 1.6</p> <p>PANAL: 22 7/16" X 14 1/8" X 5/8" (16 mm) CS: 1 11/16" X 14 15/16" CI: 1 11/16" X 14 15/16" EDA: NO EDAM:</p> <p>ENTRADA: 1 1/4" SALIDA: 1 1/4"</p> <p>003</p>
<p>LHRP269-2 RENAULT</p>  <p>CLIO II/KANGOO 00-03 L4 1.5/1.9</p> <p>PANAL: 18 13/16" X 17 1/4" X 1 1/4" (32mm) CS: 2 3/8" X 18 1/16" CI: 2 3/8" X 18 1/16" EDA: NO</p> <p>ENTRADA: 1 5/16" SALIDA: 1 5/16"</p> <p>004</p>	<p>LHRP293 RENAULT</p>  <p>MEGANE/SCENIC 03-08 1.5/1.6</p> <p>PANAL: 23 1/8" X 17 1/4" X 1 5/16" (34mm) CS: 1 7/8" X 18 5/32" CI: 1 7/8" X 18 5/32" EDA: NO</p> <p>ENTRADA: 1 1/4" SALIDA: 1 1/4"</p> <p>005</p>	<p>RT0040-24M RENAULT</p> <p>ALUMINIO MECÁNICO</p>  <p>MEGANE 06-09 L4 1.6/2.0</p> <p>RT 0040</p> <p>PANAL: 23" X 16 1/4" X 7/8" CS: 16 1/4" X 1 3/4" CI: 16 1/4" X 1 3/4" ENFRIADOR: NO</p> <p>ENTRADA: 1 1/4" SALIDA: 1 1/4"</p> <p>006</p>
<p>A2191-13C SATURN</p>  <p>Sc1 94-02 / SL BASE 94-02 L4 1.9</p> <p>DPI-2191</p> <p>PANAL: 23 9/16" X 13 15/16" X 1/2" CAB. SUP.: 2 5/16" X 15 3/8" CAB. INF.: 2 5/16" X 15 3/8" ENFRIADOR: SI, 11 1/2" 756383-M</p> <p>ENTRADA: 1 1/4" SALIDA: 1 1/4"</p> <p>007</p>	<p>A2727-28P3 CHEVROLET/PONTIAC/SATURN</p>  <p>Toma de calefacción</p> <p>Conecciones de candado</p> <p>MALIBU/G6/AURA 04-10 V6 3.5/3.9</p> <p>CONDENSADOR: AC3279</p> <p>PANAL: 26 3/4" X 14 1/16" X 1 1/8" CAB. SUP.: 14 15/16" X 1 7/8" CAB. INF.: 14 15/16" X 1 7/8" ENF. TRANS.: 11 1/2"</p> <p>TOMAS: ENTRADA: 1 5/16" SALIDA: 1 5/16"</p> <p>008</p>	<p>A2864-28C CHEVROLET/PONTIAC/SATURN</p>  <p>Conecciones de candado</p> <p>MALIBU 08-12/ G6 06-10/AURA 07-09 L4 2.4/ V6 3.6</p> <p>DPI 2864</p> <p>PANAL: 26 3/4" X 14 5/8" X 1 1/8" CAB. SUP.: 14 7/8" X 1 7/8" CAB. INF.: 14 7/8" X 1 7/8"</p> <p>TOMAS: ENTRADA: 1 5/16" SALIDA: 1 5/16"</p> <p>ENFRIADOR: SI CONDENSADOR: AC3279</p> <p>009</p>

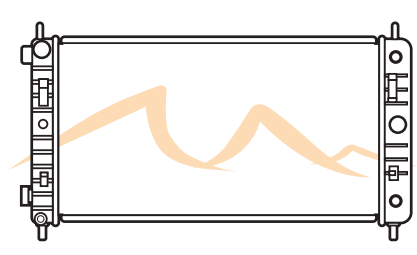
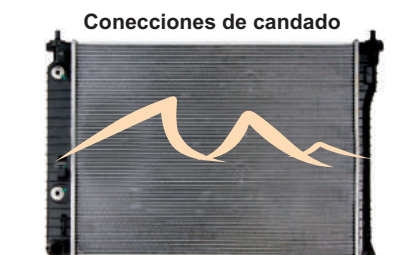
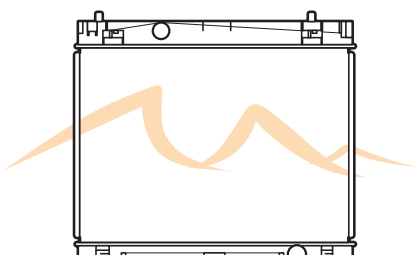
<p>A2969-13C SATURN/PONTIAC</p>  <p>SOLSTICE 00-09/SKY 07-10</p> <p>DPI 2969 L4 2.0/2.4</p> <p>PANAL: 19 1/4" X 14 5/8" X 1/2" CS: 2 7/16" X 15 3/8" CI: 2 7/16" X 15 3/8"</p> <p>ENTRADA: 1 5/16" SALIDA: 1 5/16"</p> <p>ENFRIADOR: SI</p> <p>010</p>	<p>A13007-28C SATURN/CHEVROLET/GMC/BUICK</p>  <p>ENCLAVE 08-13 / TRAVERSE 09-13 / ACADIA 07-13 / OUTLOOK 07-10</p> <p>DPI 13007 V6 3.6</p> <p>PANAL: 27 1/2" X 18 3/4" X 1 1/8" CS: 2 5/16" X 19 15/16" CI: 2 5/16" X 19 15/16"</p> <p>ENTRADA: 1 5/16" SALIDA: 1 5/16"</p> <p>ENFRIADOR: SI CONDENSADOR: AC13007</p> <p>011</p>	<p>A13050-28C SATURN/PONTIAC</p>  <p>SKY 07-10/SOLSTICE 07-09</p> <p>L4 2.0</p> <p>PANAL: 19 1/4" X 14 25/32" X 1 1/8" CAB. SUP.: 2 3/8" X 15 1/2" CAB. INF.: 2 3/8" X 15 1/2"</p> <p>ENF. TRANS.: SI ENF. MOTOR: NO</p> <p>TOMAS: ENTRADA: 1 5/16" SALIDA: 1 5/16"</p> <p>012</p>
<p>A13057-28C CHEVROLET/SATURN</p>  <p>CAPTIVA 08-16/VUE 08-10</p> <p>L4 1.5/1.6</p> <p>PANAL: 26 3/8" X 19 3/4" X 1 1/8" CS: 2 1/2" X 20 3/4" CI: 2 1/2" X 20 3/4"</p> <p>ENTRADA: 1 5/16" SALIDA: 1 5/16"</p> <p>EDA: SI</p> <p>013</p>	<p>2191 DPI SATURN</p>  <p>S-SERIES 94-02</p> <p>L4 1.9</p> <p>PANAL: 23 5/8" X 14" X 5/8" (16 mm) CS: 2 1/8" X 15 3/8" CI: 2 1/8" X 15 3/8"</p> <p>ENTRADA: 1 1/4" SALIDA: 1 1/4"</p> <p>EDA: SI EDAM: NO</p> <p>014</p>	<p>2608 DPI SATURN/PONTIAC/CHEVROLET</p>  <p>COBALT 07-10/G5 07-10/ION 03-07</p> <p>L4 2.0/2.2/2.4</p> <p>PANAL: 26 3/4" X 14 1/8" X 5/8" (16 mm) CS: 2 1/4" X 15 1/2" CI: 2 1/4" X 15 1/2"</p> <p>ENTRADA: 1 3/4" SALIDA: 1 3/4"</p> <p>EDA: 11 1/2" 4 PLACAS EDAM: NO</p> <p>015</p>
<p>2727 DPI SATURN/CHEVROLET/GM</p>  <p>AURA 07-08/G6/MALIBU 05-06/04-06</p> <p>V6 3.5/3.9</p> <p>PANAL: 26 3/4" X 14 1/2" X 1" (26 mm) CS: 1 7/8" X 14 15/16" CI: 1 7/8" X 14 15/16"</p> <p>ENTRADA: 1 5/16" SALIDA: 1 3/8"</p> <p>EDA: SI EDAM: NO</p> <p>016</p>	<p>13057 DPI CHEVROLET/SATURN</p>  <p>CAPTIVA SPORT/VUE 08-15</p> <p>L4 2.4 / V6 3.0 / 3.5 / 3.6</p> <p>PANAL: 26 1/2" X 19 3/4" X 1" CAB. SUP.: 2 1/2" X 20 11/16" CAB. INF.: 2 1/2" X 20 11/16"</p> <p>Enfriador: SI</p> <p>TOMAS: ENTRADA: 1 5/16" SALIDA: 1 5/16"</p> <p>017</p>	<p>A2889-13N SCION/TOYOTA</p>  <p>YARIS 06-12/ XD 08-11</p> <p>L4 1.5</p> <p>PANAL: 13 3/4" X 18 5/8" X 1/2" CS: 1 1/4" X 19 15/16" CI: 1 9/16" X 19 15/16"</p> <p>ENTRADA: 1 1/4" SALIDA: 1 1/4"</p> <p>EDA: SI</p> <p>CONDENSADOR: AC3580</p> <p>018</p>

A2890-13C SCION/TOYOTA

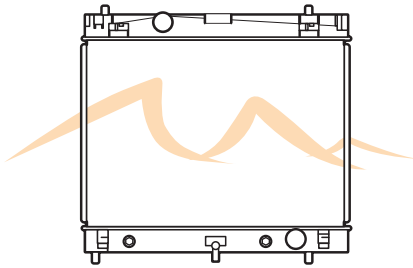

YARIS 06-12/XD 08-11
L4 1.3/1.8

PANAL: 13 3/4" X 18 5/8" X 1/2"
CS: 1 1/4" X 19 15/16" ENTRADA: 1 1/4"
CI: 1 9/16" X 19 15/16" SALIDA: 1 1/4"
EDA: SI

CONDENSADOR: AC3580

019

**PRUEBA NUESTRA
VERSION IMPRESA
EN LINEA**

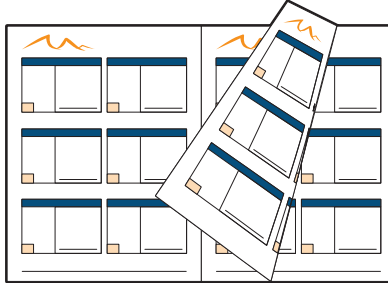

www.phar.com.mx

**My
PHAR**

www.phar.com.mx





NOTAS

Radiadores

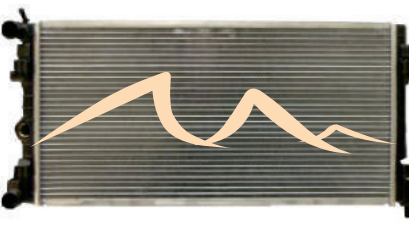
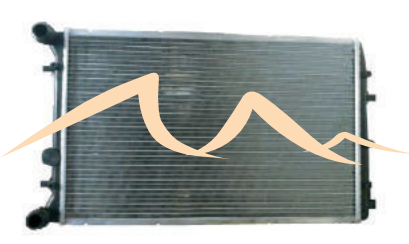
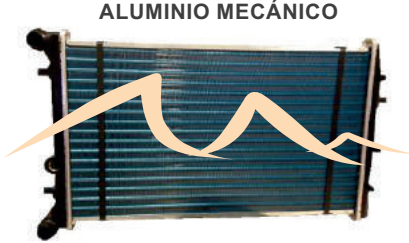
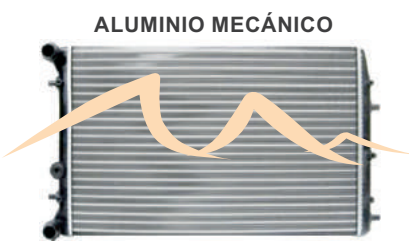
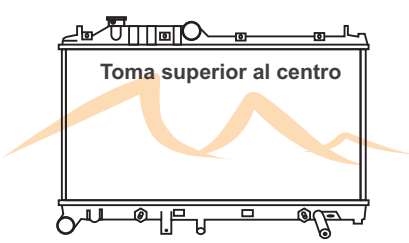
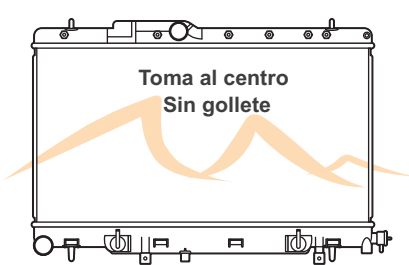
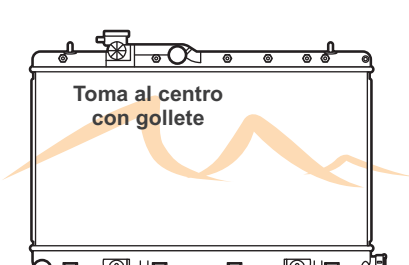
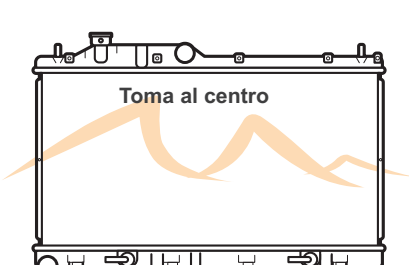
PHAR

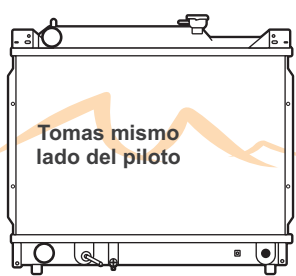
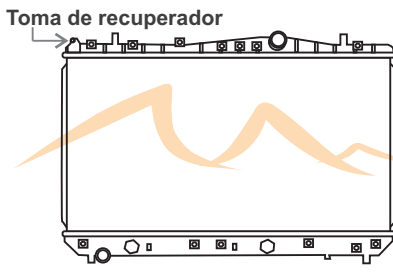
- **SEAT**
- **SUBARU**
- **SUZUKI**

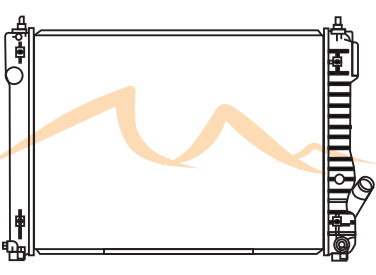
<p>A020-28N AUDI/SEAT/VW</p>  <p>Toma de candado lado piloto</p> <p>A3/LEON/TOLEDO/GOLF 05 L4 1.4/1.9/2.0</p> <p>PANAL: 25 1/2" X 15 5/8" X 1 1/8" CAB. SUP.: 1 11/16" X 16 3/8" CAB. INF.: 1 11/16" X 16 3/8" ENF. TRANS.: NO ENF. MOTOR: NO</p> <p>TOMAS: ENTRADA: 1 5/16" SALIDA: 1 5/16"</p> <p>001</p>	<p>A025-28N SEAT/AUDI/VW</p>  <p>IBIZA 02-10/A1 11-12/POLO 13-14/VENTO 14-15 L4 1.8/1.9/1.6</p> <p>PANAL: 25 1/2" X 12 3/8" X 1 1/8" CS: 1 15/16" X 13 3/8" CI: 1 15/16" X 13 3/8"</p> <p>ENFRIADOR: NO</p> <p>ENTRADA: 1 1/4" SALIDA: 1 1/4"</p> <p>002</p>	<p>A045-28N SEAT</p>  <p>IBIZA / CORDOBA 03-07 L4 1.4/1.6/2.0</p> <p>ST0010-24M</p> <p>PANAL: 24 3/4" X 15 3/16" X 1 1/8" CAB. SUP.: 16 15/16" X 1 5/8" CAB. INF.: 16 15/16" X 1 5/8"</p> <p>ENFRIADOR: NO</p> <p>ENTRADA: 1 1/4" SALIDA: 1 1/4"</p> <p>003</p>
<p>M045-26N SEAT</p>  <p>ALUMINIO MECÁNICO</p> <p>IBIZA/CORDOBA 02-07 L4 1.4/1.6/2.0</p> <p>ST 0010-24M</p> <p>PANAL: 24 3/4" X 14 15/16" X 1 CS: 16 15/16" X 1 5/8" CI: 16 15/16" X 1 5/8"</p> <p>ENFRIADOR: NO</p> <p>ENTRADA: 1 1/4" SALIDA: 1 1/4"</p> <p>004</p>	<p>ST0010-24M SEAT</p>  <p>ALUMINIO MECÁNICO</p> <p>IBIZA/CORDOBA 99-04 L4 1.8/2.0</p> <p>ST 0010</p> <p>PANAL: 24 3/4" X 16 1/4" X 7/8" CS: 16 1/2" X 1 3/4" CI: 16 1/2" X 1 3/4"</p> <p>ENFRIADOR: NO</p> <p>ENTRADA: 1 1/4" SALIDA: 1 1/4"</p> <p>005</p>	<p>A2777-13C SUBARU</p>  <p>Toma superior al centro</p> <p>FORESTER 09-13 / OUTBACK 05-09 / LEGACY 05-09 / IMPREZA 08-13 H4 2.0/2.5</p> <p>DPI 2777</p> <p>PANAL: 13 3/8" X 27" X 1/2" CS: 1 7/16" X 28 1/8" CI: 1 7/16" X 28 1/8"</p> <p>ENFRIADOR: SI</p> <p>ENTRADA: 1 9/16" SALIDA: 1 9/16"</p> <p>006</p>
<p>2450 DPI SUBARU</p>  <p>Toma al centro Sin gollete</p> <p>IMPREZA 02-03 H4 2.0</p> <p>PANAL: 13 3/8" X 27 3/16" X 1" (26 mm) CS: 1 15/16" X 28 1/8" CI: 2 7/16" X 28 1/8" EDA: 14 3/4" Concéntrico EDAM: NO</p> <p>ENTRADA: 1 1/2" SALIDA: 1 1/2"</p> <p>007</p>	<p>2703 DPI SUBARU/SAAB</p>  <p>Toma al centro con gollete</p> <p>9-2X 05-06/IMPREZA 03-07/BAJA 04-06 H4 2.0/2.5</p> <p>PANAL: 13 3/8" X 27" X 1" (26 mm) CS: 1 7/8" X 28 1/16" CI: 2 1/4" X 28 1/16"</p> <p>ENFRIADOR: SI</p> <p>ENTRADA: 1 1/2" SALIDA: 1 1/2"</p> <p>008</p>	<p>2778 DPI SUBARU</p>  <p>Toma al centro</p> <p>OUTBACK/LEGACY 05-09 H4 2.5</p> <p>PANAL: 13 3/8" X 27" X 5/8" (16 mm) CS: 1 7/16" X 28 1/16" CI: 1 7/16" X 28 1/16"</p> <p>ENFRIADOR: SI</p> <p>ENTRADA: 1 9/16" SALIDA: 1 9/16"</p> <p>009</p>

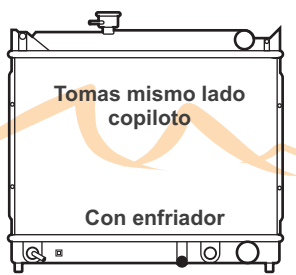
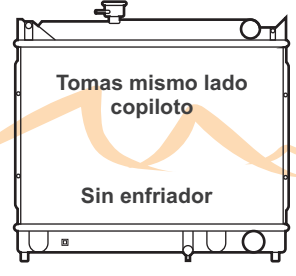
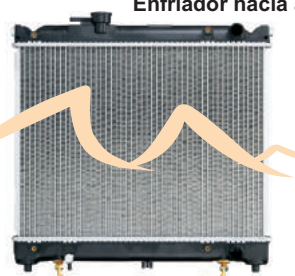
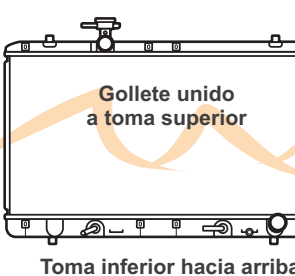
<p>A2087-28C SUZUKI</p>  <p>Tomas mismo lado del piloto</p> <p>TRACKER/GRAND VITARA 96-97/99-00</p> <p>DPI 2807 L4 1.6/1.8/2.0 V6 2.5/2.7</p> <p>PANAL: 16 3/4" X 20 3/4" X 1" (26 mm) CS: 1 7/8" X 21 3/8" ENTRADA: 1 1/4" CI: 1 7/8" X 21 3/8" SALIDA: 1 1/4" EDA: 13 3/4" EDAM: NO</p> <p>010</p>	<p>A2788-13C CHEVROLET/GMC/SUZUKI</p>  <p>Toma de recuperador</p> <p>RENO/FORENZA 04-08/OPTRA 04-07</p> <p>L4 2.0</p> <p>PANAL: 14 7/8" X 28 5/8" X 1 1/2" CS: 1 13/16" X 28 3/16" ENTRADA: 1 3/8" CI: 2" X 28 3/16" SALIDA: 1 3/8" EDA: SI EDAM: NO</p> <p>011</p>	<p>A2920-13C SUZUKI</p>  <p>Toma en orilla hacia arriba Lado del piloto</p> <p>GRAND VITARA 06-13</p> <p>DPI 2920 L4 2.4 V6 2.7/3.2</p> <p>PANAL: 17 9/16" X 25 3/4" X 3 1/4" CS: 1 7/8" X 28 1/4" ENTRADA: 1 3/8" CI: 1 7/8" X 28 1/4" SALIDA: 1 3/8"</p> <p>ENFRIADOR: SI, 752920-M</p> <p>012</p>
<p>A13097-28N SUZUKI/CHEVROLET/GMC</p>  <p>SWIFT 2009/AVEO 09-11/G3 09</p> <p>DPI 13097 L4 2.0/ L6 2.5/3.0</p> <p>PANAL: 23 1/2" X 16 3/8" X 1 1/8" CS: 1 13/16" X 17 1/4" ENTRADA: 1 5/16" CI: 1 13/16" X 17 1/4" SALIDA: 1 5/16"</p> <p>ENFRIADOR: NO</p> <p>013</p>	<p>1444 DPI SUZUKI/GEO</p>  <p>Gollete y tomas lado del piloto</p> <p>SWIRT/METRO 89-94</p> <p>L3 1.0 L4 1.3/1.6</p> <p>PANAL: 12 3/4" X 13" X 1" (26 mm) CS: 2" X 13 3/4" ENTRADA: 1 1/8" CI: 2" X 13 3/4" SALIDA: 1 1/8" EDA: 8" EDAM: NO</p> <p>014</p>	<p>1864 DPI SUZUKI/CHEVROLET/GEO</p>  <p>Tomas mismo lado copiloto Con enfriador</p> <p>SIDEKICK 92-98/TRACKER 93-98</p> <p>A/T L4 1.6</p> <p>PANAL: 16 3/4" X 19 1/4" X 1" (26 mm) CS: 2" X 19 7/8" ENTRADA: 1 1/8" CI: 2" X 19 7/8" SALIDA: 1 1/8" EDA: 12 3/4" EDAM: NO NOTAS: Substituye ST. 2088</p> <p>015</p>
<p>2088 DPI SUZUKI/CHEVROLET/GEO</p>  <p>Tomas mismo lado copiloto Sin enfriador</p> <p>SIDEKICK/TRACKER M/T 96-97/96-98</p> <p>M/T L4 1.6</p> <p>PANAL: 16 3/4" X 20 3/4" X 1" (26 mm) CS: 1 7/8" X 21 3/8" ENTRADA: 1 1/4" CI: 1 7/8" X 21 3/8" SALIDA: 1 1/4" EDA: NO EDAM: NO</p> <p>016</p>	<p>2089 DPI GEO/SUZUKI</p>  <p>Enfriador hacia abajo</p> <p>TRACKER X-90 94-98</p> <p>DPI 2089 / 6132 PHAR L4 1.6</p> <p>PANAL: 14 7/8" X 19 3/16" X 1 1/4" CAB. SUP.: 1 15/16" X 19 15/16" CAB. INF.: 1 15/16" X 19 15/16" Enfriador: NO</p> <p>TOMAS: ENTRADA: 1 1/8" SALIDA: 1 1/8"</p> <p>017</p>	<p>2451 DPI SUZUKI</p>  <p>Gollete unido a toma superior Toma inferior hacia arriba</p> <p>AERIO 02-07</p> <p>L4 2.0/2.3</p> <p>PANAL: 13 3/4" X 28 1/4" X 1" (26 mm) CS: 1 7/8" X 28 15/16" ENTRADA: 1 5/16" CI: 1 7/8" X 28 5/16" SALIDA: 1 5/16" EDA: SI</p> <p>018</p>

2774 DPI SUZUKI/CHEVROLET/GM/PONTIAC

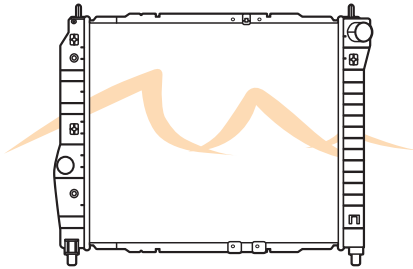

SWIFT 04-08/G3 05-08/AVEO 04-08

L4 1.6

PANAL: 16 3/8" X 18 7/8" X 5/8" (16 mm)
 CS: 1 13/16" X 17 5/16" ENTRADA: 1 5/16"
 CI: 1 13/16" X 17 5/16" SALIDA: 1 5/16"
 EDA: SI
 EDAM: NO

019

2788 DPI SUZUKI/CHEVROLET/GMC

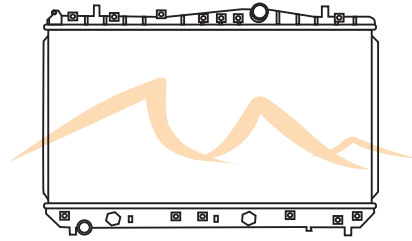

RENO/FORENZA/OPTRA 04-07

L4 2.0

PANAL: 14 5/8" X 27 1/2" X 5/8" (16 mm)
 CS: 1 13/16" X 28 1/4" ENTRADA: 1 5/16"
 CI: 2" X 28 1/4" SALIDA: 1 1/2"
 EDA: SI
 EDAM: NO

020

2873 DPI SUZUKI/CHEVROLET/GM/PONTIAC

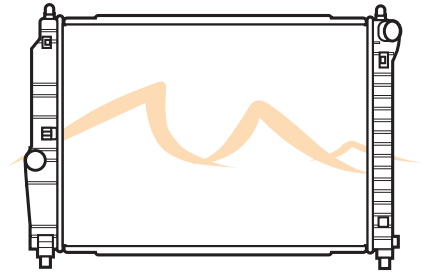

SWIFT 04-08/G3 05-08/AVEO 04-08

L4 1.6

PANAL: 23 5/8" X 16 3/8" X 5/8" (16 mm)
 CS: 1 13/16" X 17 1/4" ENTRADA: 1 3/8"
 CI: 1 13/16" X 17 1/4" SALIDA: 1 3/8"
 EDA: 10" 3 PLACAS
 EDAM: NO

021

2980 DPI

SUZUKI

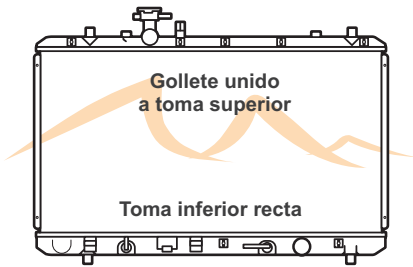

Sx4 07-09

L4 2.0

PANAL: 14 3/4" X 27 15/16" X 1" (26 mm)
 CS: 1 13/16" X 28 15/16" ENTRADA: 1 5/16"
 CI: 1 13/16" X 28 15/16" SALIDA: 1 5/16"
 EDA: SI

022

13136 DPI

SUZUKI

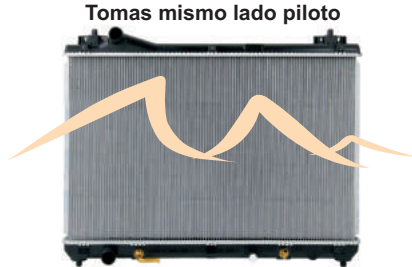

GRAND VITARA 09-15

L4 2.4

PANAL: 17 11/16" X 27 3/16" X 5/8"
 CAB. SUP.: 1 15/16" X 28 3/16" TOMAS:
 CAB. INF.: 1 15/16" X 28 3/16" ENTRADA: 1 5/16"
 Enfriador: NO SALIDA: 1 5/16"

023

My
PHAR

www.phar.com.mx

Escanea nuestro código QR con tu smartphone

Descarga la aplicación desde tu Smartphone en: www.2dscan.com

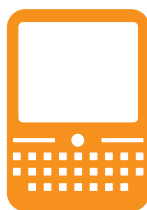

Radiadores



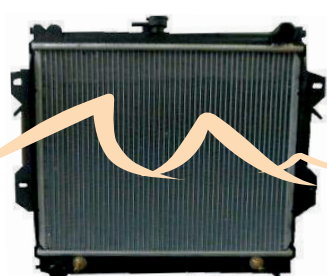
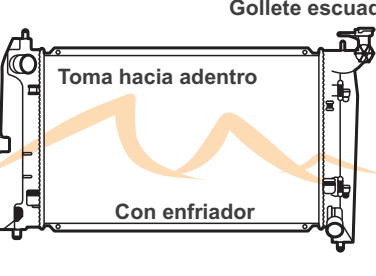
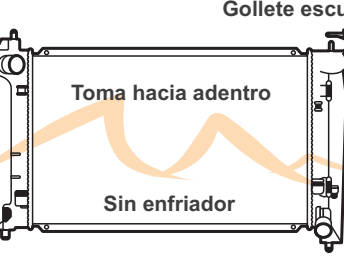
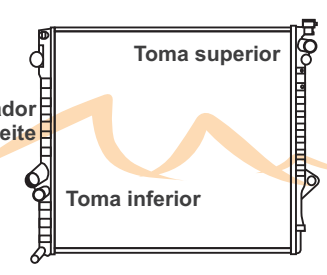
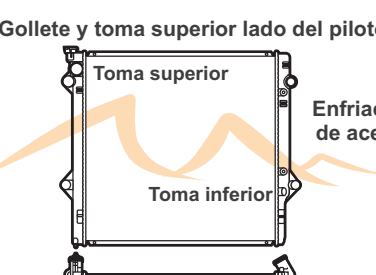
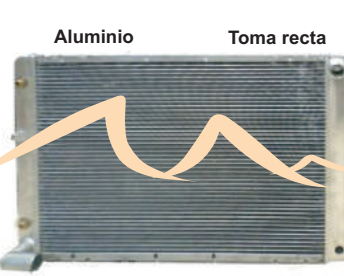
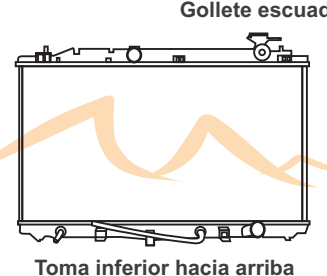
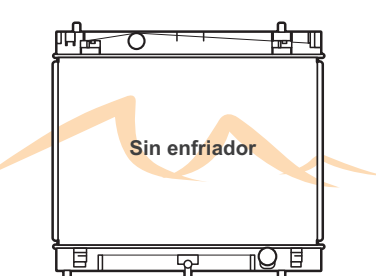

PHAR

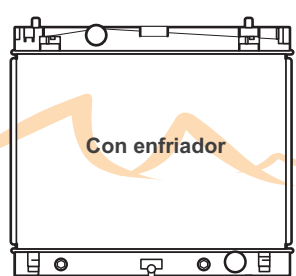
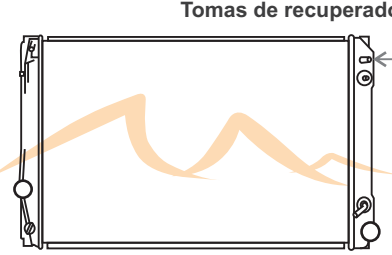
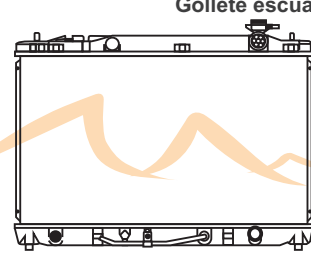
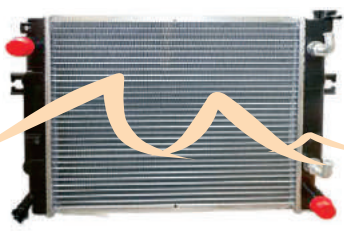
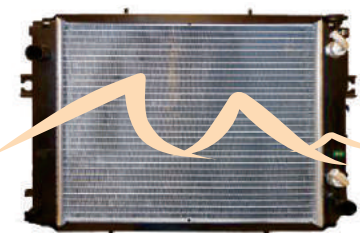
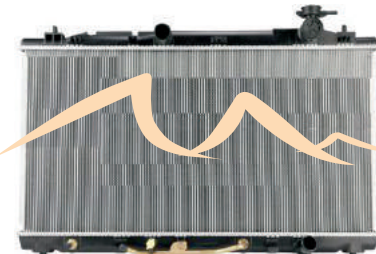
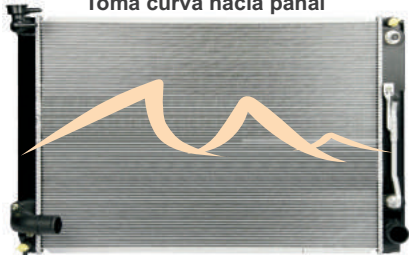
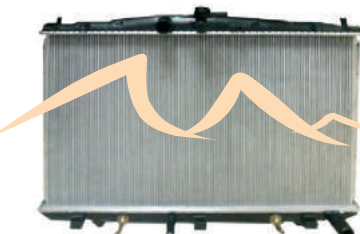
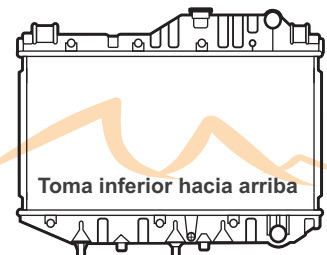
· TOYOTA

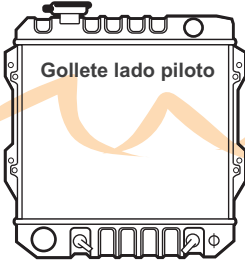
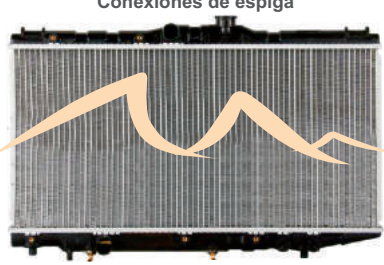
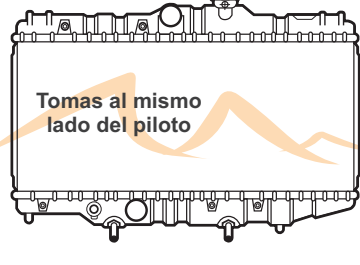
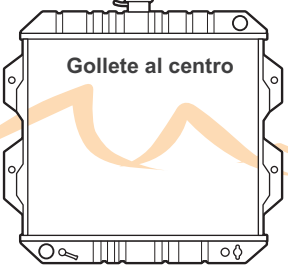
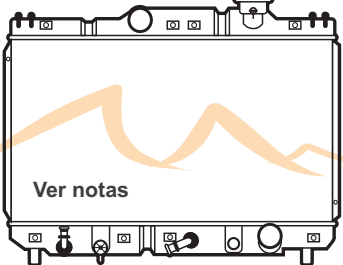
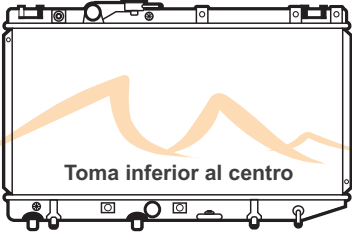
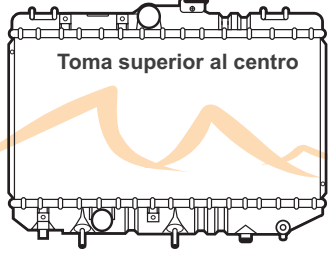
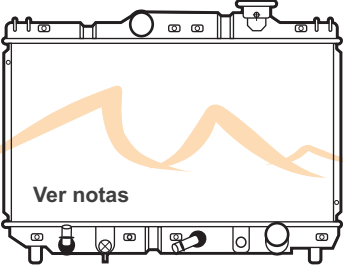
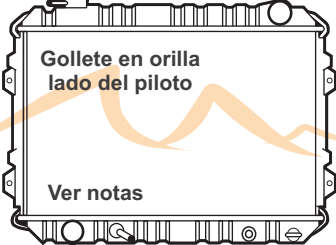

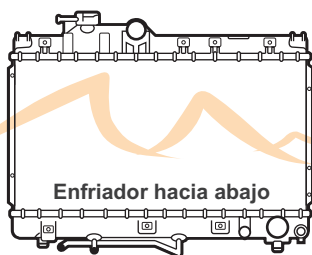
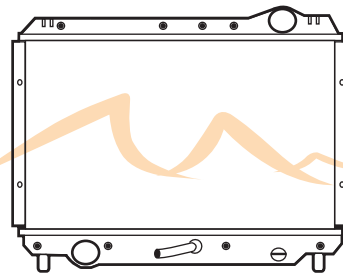
<p>A012-44P7 TOYOTA</p>  <p>Enfriadores 11" entre centros 8 placas 8" entre centros 10 placas</p> <p>Incluye conexiones</p> <p>Doble enfriador</p> <p>MONTACARGAS 90-11</p> <p>L4 2.2 Gasolina L6 4.3 Gas Lp, Diesel</p> <p>PANAL: 20 3/4" X 18" X 1 3/4" CS: 2 11/16" X 18 1/4" CI: 2 11/16" X 18 1/4"</p> <p>ENTRADA: 1 5/16" SALIDA: 1 5/16"</p> <p>ENFRIADOR: SI TOC: 113150 EOC: 750012-M // OEM:16410V335071/336071</p> <p>001</p>	<p>A0945-28C TOYOTA</p>  <p>SERIES PICK UP 85-95/4 RUNNER 92-95</p> <p>L4 2.4</p> <p>PANAL: 15 3/4" X 19 5/8" X 1 1/8" CAB. SUP.: 2 1/4" X 20 3/4" CAB. INF.: 2 1/4" X 20 3/4"</p> <p>ENF. TRANS.: SI ENF. MOTOR: NO</p> <p>CONDENSADOR: AC3932</p> <p>TOMAS: ENTRADA: 1 5/16" SALIDA: 1 5/16"</p> <p>002</p>	<p>A2428-28C TOYOTA/PONTIAC</p>  <p>Gollete escuadra</p> <p>Toma hacia adentro</p> <p>Con enfriador</p> <p>VIBE 03-08/MATRIX/COROLLA 03-08</p> <p>DPI 2428 L4 1.8</p> <p>PANAL: 23 5/8" X 13 11/16" X 1 1/8" CS: 1 5/16" X 14 5/8" CI: 1 5/16" X 14 5/8"</p> <p>ENTRADA: 1 3/8" SALIDA: 1 3/8"</p> <p>ENFRIADOR: SI</p> <p>003</p>
<p>A2432-28N TOYOTA/PONTIAC</p>  <p>Gollete escuadra</p> <p>Toma hacia adentro</p> <p>Sin enfriador</p> <p>VIBE 03-08/MATRIX/COROLLA 03-08</p> <p>DPI 2432 L4 1.8</p> <p>PANAL: 23 5/8" X 13 11/16" X 1 1/8" CS: 1 5/16" X 14 5/8" CI: 1 9/16" X 14 5/8"</p> <p>ENTRADA: 1 5/16" SALIDA: 1 5/16"</p> <p>ENFRIADOR: NO</p> <p>004</p>	<p>A2580-28C TOYOTA</p>  <p>Toma superior</p> <p>Enfriador de aceite</p> <p>Toma inferior</p> <p>4RUNNER 03-09 / FJ CRUSIER 07-13</p> <p>DPI 2580 V6 4.0</p> <p>PANAL: 25 9/16" X 23 1/4" X 1 1/8" CS: 2 1/4" X 24 7/16" CI: 2 1/4" X 24 7/16"</p> <p>ENTRADA: 1 3/8" SALIDA: 1 3/8"</p> <p>ENFRIADOR: SI</p> <p>005</p>	<p>A2581-28C TOYOTA/LEXUS</p>  <p>Gollete y toma superior lado del piloto</p> <p>Toma superior</p> <p>Enfriador de aceite</p> <p>Toma inferior</p> <p>4 RUNNER 03-09/GX470 03-09</p> <p>DPI 2581 V8 4.7</p> <p>PANAL: 25 5/8" X 23 1/8" X 1 1/8" CS: 2 1/8" X 24 3/16" CI: 2 1/8" X 24 3/16"</p> <p>ENTRADA: 1 1/2" SALIDA: 1 1/2"</p> <p>EDA: SI</p> <p>006</p>
<p>A2681-13C TOYOTA</p>  <p>Aluminio Toma recta</p> <p>Toma curva hacia panel</p> <p>SIENNA 04-06</p> <p>DPI 2681 V6 3.3</p> <p>PANAL: 26 3/8" X 18 1/2" X 1/2" CS: 1 7/16" X 20 1/4" CI: 1 7/16" X 20 1/4"</p> <p>ENTRADA: 1 3/8" SALIDA: 1 1/2"</p> <p>EDA: SI 752920-M</p> <p>CONDENSADOR: AC3284</p> <p>007</p>	<p>A2817-13C TOYOTA</p>  <p>Gollete escuadra</p> <p>Toma inferior hacia arriba</p> <p>CAMRY 05-11/ AVALON 05-13</p> <p>DPI 2817 L4 2.4 V6 3.5</p> <p>PANAL: 15 3/4" X 29 7/8" X 1/2" CS: 1 9/16" X 30 7/8" CI: 1 9/16" X 30 7/8"</p> <p>ENTRADA: 1 3/8" SALIDA: 1 3/8"</p> <p>ENFRIADOR: SI</p> <p>008</p>	<p>A2889-13N TOYOTA/SCION</p>  <p>Sin enfriador</p> <p>M/T YARIS 06-13/ XD 08-13</p> <p>DPI 2889 L4 1.5/1.8</p> <p>PANAL: 13 3/4" X 18 5/8" X 1/2" CS: 1 1/4" X 19 15/16" CI: 1 9/16" X 19 15/16"</p> <p>ENTRADA: 1 1/4" SALIDA: 1 1/4"</p> <p>EDA: SI</p> <p>CONDENSADOR: AC3580</p> <p>009</p>

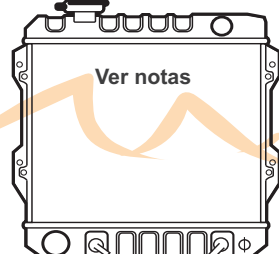
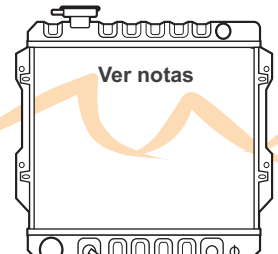
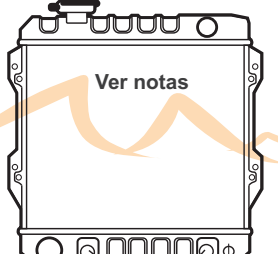
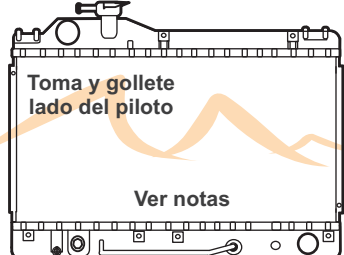

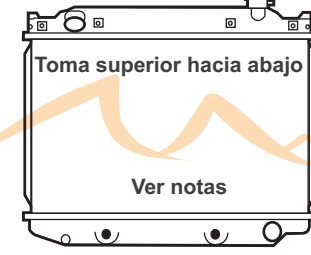
<p>A2890-13C TOYOTA/SCION</p>  <p>Con enfriador</p> <p>A/T YARIS 06-13/XD 08-13</p> <p>DPI 2890 L4 1.5/1.8</p> <p>PANAL: 13 3/4" X 18 5/8" X 1/2" CS: 1 1/4" X 19 15/16" CI: 1 9/16" X 19 15/16" EDA: SI</p> <p>CONDENSADOR: AC3580</p> <p>ENTRADA: 1 1/4" SALIDA: 1 1/4"</p> <p>010</p>	<p>A2893-28C TOYOTA</p>  <p>Tomas de recuperador</p> <p>RAV 4 06-12</p> <p>DPI 2890 L4 2.5 V6 3.5</p> <p>PANAL: 26 1/2" X 17" X 1 1/8" CS: 1 9/16" X 18 1/4" CI: 1 9/16" X 18 1/4" EDA: SI</p> <p>CONDENSADOR: AC3575</p> <p>ENTRADA: 1 1/2" SALIDA: 1 1/2"</p> <p>011</p>	<p>A2917-13C TOYOTA</p>  <p>Gollete escuadra</p> <p>Toma inferior hacia arriba</p> <p>CAMRY 07-11</p> <p>DPI 2917 L4 2.4 V6 3.5</p> <p>PANAL: 15 3/4" X 28 5/16" X 1/2" CS: 1 7/16" X 29 13/16" CI: 2" X 29 13/16"</p> <p>ENFRIADOR: SI, 752817-M</p> <p>ENTRADA: 1 3/8" SALIDA: 1 3/8"</p> <p>012</p>
<p>A8042-44P7 TOYOTA</p>  <p>MONTACARGAS 90-11</p> <p>PHAR CAVTU-8042-3 L4 2.2 L6 4.3</p> <p>PANAL: 17 3/4" X 17 3/16" X 1 3/4" CAB. SUP.: 2 11/16" X 18 5/16" CAB. INF.: 2 11/16" X 18 5/16"</p> <p>ENFRIADOR: SI, 10 3/4" 113-150</p> <p>ENTRADA: 1 5/16" SALIDA: 1 5/16"</p> <p>013</p>	<p>A8043-44P7 TOYOTA</p>  <p>MONTACARGAS 07-11</p> <p>PHAR CAVTU-8043-3</p> <p>PANAL: 19 5/8" X 17 3/4" X 1 3/4" CAB. SUP.: 3 3/8" X 17 1/2" CAB. INF.: 3 3/8" X 17 1/2"</p> <p>ENFRIADOR: SI, 10 3/4" 113-150</p> <p>ENTRADA: 1 5/16" SALIDA: 1 5/16"</p> <p>014</p>	<p>A13035-13C LEXUS/TOYOTA</p>  <p>CAMRY 07-11/ES350 07-12</p> <p>PANAL: 15 3/4" X 28 5/16" X 1/2" CS: 1 7/8" X 31 1/4" CI: 1 7/8" X 31 1/4" EDA: 14 3/4" 752817-M</p> <p>ENTRADA: 1 3/8" SALIDA: 1 3/8"</p> <p>015</p>
<p>A13076-13C TOYOTA</p>  <p>Toma curva hacia panel</p> <p>Tomas lineales</p> <p>SIENNA 07-10</p> <p>DPI 13076 V6 3.5</p> <p>PANAL: 26 1/2" X 18 13/16" X 1/2" CAB. SUP.: 1 9/16" X 19 7/8" CAB. INF.: 1 9/16" X 19 7/8"</p> <p>ENFRIADOR: SI</p> <p>CONDENSADOR: AC3284</p> <p>TOMAS: ENTRADA: 1 9/16" SALIDA: 1 1/2"</p> <p>016</p>	<p>A13116-13C TOYOTA</p>  <p>Gollete al centro</p> <p>SIENNA 11-14</p> <p>DPI 13116 L4 2.7 V6 3.5</p> <p>PANAL: 17 5/8" X 29 3/4" X 1/2" CAB. SUP.: 31 1/4" X 1 7/8" CAB. INF.: 31 1/4" X 1 7/8"</p> <p>ENFRIADOR: SI, 14 3/4" 752817-M</p> <p>ENTRADA: 1 3/8" SALIDA: 1 3/8"</p> <p>CONDENSADOR: AC3869</p> <p>017</p>	<p>0021 DPI TOYOTA/LEXUS</p>  <p>Toma inferior hacia arriba</p> <p>Enfriador hacia abajo</p> <p>Es250 90-91/CAMRY 87-91</p> <p>DPI 0021 V6 2.5</p> <p>PANAL: 12 7/8" X 27" X 1 1/4" (32 mm) CS: 2" X 27 7/8" CI: 2" X 27 7/8" EDA: 10 3/4" EDAM: NO</p> <p>ENTRADA: 1 5/16" SALIDA: 1 1/4"</p> <p>018</p>

<p>0050 DPI TOYOTA</p>  <p>Gollete lado piloto</p> <p>PICK UP/4 RUNNER 88-95 V6 3.0</p> <p>PANAL: 18 3/4" X 20 3/4" X 2" (49 mm) CS: 2 1/2" X 21" CI: 2 1/2" X 21" EDA: 12 1/2" EDAM: NO CONDENSADOR: AC3932</p> <p>019</p>	<p>0537 DPI TOYOTA</p>  <p>Conexiones de espiga</p> <p>COROLLA 88-92/GEO PRIZM 89-92 L4 1.6</p> <p>PANAL: 12 7/8" X 26 5/16" X 5/8" CS: 2" X 27 1/8" CI: 2" X 27 1/8" EDA: SI Concentrico 8 7/8" EDAM: NO</p> <p>020</p>	<p>0539 DPI TOYOTA/GEO</p>  <p>Tomas al mismo lado del piloto</p> <p>PRIZM 89-92/COROLLA 88-92 L4 1.5</p> <p>4674 PHAR</p> <p>PANAL: 12 3/4" X 26 3/8" X 1 1/4" (32 mm) CS: 2" X 27" CI: 2" X 27" EDA: 8 7/8" EDAM: NO</p> <p>021</p>
<p>0945 DPI TOYOTA</p>  <p>Gollete al centro</p> <p>4 RUNNER/PICK UP 84-95/84-95 L4 2.4</p> <p>PANAL: 15 3/4" X 20 3/4" X 1 1/4" (32 mm) CS: 1 7/8" X 20 7/8" CI: 1 7/8" X 20 7/8" EDA: 14 3/8" EDAM: NO</p> <p>022</p>	<p>1318 DPI TOYOTA</p>  <p>Ver notas</p> <p>CAMRY 92-96 L4 2.2</p> <p>PANAL: 16 3/4" X 28 1/4" X 5/8" (16 mm) CS: 1 3/8" X 29" CI: 2" X 29" EDA: 14 3/4" EDAM: NO NOTAS: Puede usar HD 2 Lineas 1428</p> <p>023</p>	<p>1319 DPI TOYOTA</p>  <p>Toma inferior al centro Enfriador de aceite hacia abajo</p> <p>TERCEL/PASEO 91-95 L4 1.5</p> <p>PANAL: 12 3/4" X 27 1/2" X 1" (26 mm) CS: 1 7/8" X 28 1/8" CI: 1 7/8" X 28 1/8" EDA: 8 7/8" EDAM: NO</p> <p>024</p>
<p>1409 DPI TOYOTA/GEO</p>  <p>Toma superior al centro Enfriador hacia abajo</p> <p>COROLLA/PRIZM 93-97 L4 1.6/1.8</p> <p>PANAL: 13 3/4" X 27 1/2" X 1" (26 mm) CS: 1 7/8" X 28 1/4" CI: 1 7/8" X 28 1/4" EDA: 8 7/8" EDAM: NO NOTAS: Substituye 1436/1462</p> <p>025</p>	<p>1428 DPI TOYOTA</p>  <p>Ver notas</p> <p>CAMRY 94-96 L4 2.2</p> <p>PANAL: 16 3/4" X 28 1/4" X 1 1/4" (32 mm) CS: 1 7/8" X 28 15/16" CI: 1 7/8" X 28 15/16" EDA: 14 3/4" EDAM: NO NOTAS: Substituye 1 linea 1318</p> <p>026</p>	<p>1512 DPI TOYOTA</p>  <p>Gollete en orilla lado del piloto Ver notas</p> <p>T-100 93-98 L4 2.7 v6 3.0/3.4</p> <p>PANAL: 17 5/8" X 27 1/2" X 2" (49 mm) CS: 2 1/4" X 28 1/4" CI: 2 1/4" X 28 1/4" EDA: 16 3/4" EDAM: NO NOTAS: Puede usar 2090</p> <p>027</p>

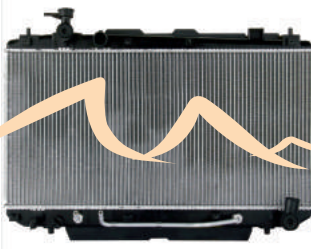
<p>1575 DPI TOYOTA</p>  <p>CELICA 94-99 L4 2.2</p> <p>PANAL: 13 3/4" X 25 3/8" X 1" (26 mm) CS: 2" X 26" CI: 2 X 26" EDA: 8 7/8" EDAM: NO</p> <p>ENTRADA: 1 1/4" SALIDA: 1 1/4"</p> <p>028</p>	<p>1746 DPI TOYOTA/LEXUS</p>  <p>AVALON 95-99/CAMRY/ES300 94-96 V6 3.9</p> <p>PANAL: 16 3/4" X 28 1/4" X 1 1/8" (28 mm) CS: 1 7/8" X 29" CI: 1 7/8" X 29" EDA: 14 3/4" EDAM: NO</p> <p>ENTRADA: 1 3/8" SALIDA: 1 3/8"</p> <p>029</p>	<p>1750 DPI TOYOTA</p>  <p>TERCEL/PASEO 95-99 L4 1.5</p> <p>PANAL: 12 3/4" X 25 1/4" X 1" (26 mm) CS: 1 7/8" X 26" CI: 1 7/8" X 26" EDA: 8 7/8" EDAM: NO</p> <p>ENTRADA: 1 1/8" SALIDA: 1 1/8"</p> <p>030</p>
<p>1755 DPI TOYOTA</p>  <p>TACOMA 95-04 L4 2.7 V6 3.4</p> <p>PANAL: 22 5/8" X 25 1/4" X 1 1/4" (32 mm) CS: 2 1/16" X 25 3/4" CI: 2 1/16" X 25 3/4" EDA: 16 3/4" EDAM: NO NOTAS: ALTO 22 5/8"</p> <p>ENTRADA: 1 3/8" SALIDA: 1 3/8"</p> <p>031</p>	<p>1774 DPI TOYOTA</p>  <p>8033 PHAR L4 2.4/2.7 V6 3.4</p> <p>PANAL: 20 5/8" X 25 1/4" X 1 1/4" (32 mm) CS: 2 1/16" X 25 3/4" CI: 2 1/16" X 25 3/4" EDA: 16 3/4" EDAM: NO NOTAS: ALTO 20 5/8"</p> <p>ENTRADA: 1 3/8" SALIDA: 1 3/8"</p> <p>032</p>	<p>1778 DPI TOYOTA</p>  <p>8034 PHAR L4 2.7 V6 3.4</p> <p>PANAL: 18 5/8" X 25 1/4" X 1 1/4" (32 mm) CS: 2 1/16" X 25 3/4" CI: 2 1/16" X 25 3/4" EDA: 16 3/4" EDAM: NO NOTAS: También en 36 mm (1 7/16") 1 Línea</p> <p>ENTRADA: 1 3/8" SALIDA: 1 3/8"</p> <p>033</p>
<p>1859 DPI TOYOTA</p>  <p>RAV4 96-98 L4 2.0</p> <p>PANAL: 13 3/4" X 27 3/4" X 1" (26 mm) CS: 1 5/8" X 28 3/8" CI: 2" X 28 3/8" EDA: 15 3/4" EDAM: NO NOTAS: Puede substituir ST. 1860</p> <p>ENTRADA: 1 1/4" SALIDA: 1 1/4"</p> <p>034</p>	<p>1917 DPI TOYOTA/LEXUS</p>  <p>LX 450 96-97/LAND CRUISER 93-97 L6 4.5</p> <p>PANAL: 16 3/4" X 28 5/8" X 2" (49 mm) CS: 2 3/4" X 29 1/4" CI: 2 3/4" X 29 1/4" EDA: 15 3/8" EDAM: NO</p> <p>ENTRADA: 1 1/2" SALIDA: 1 5/8"</p> <p>035</p>	<p>1918 DPI TOYOTA/LEXUS</p>  <p>LAND CRUISER 93-97/LX450 95-98 L6 4.5</p> <p>PANAL: 16 3/4" X 28 5/8" X 2" (49 mm) CS: 2 11/16" X 28 3/8" CI: 2 11/16" X 28 3/8" EDA: SI EDAM: NO NOTAS: Puede usar 1917</p> <p>ENTRADA: 1 1/2" SALIDA: 1 9/16"</p> <p>036</p>

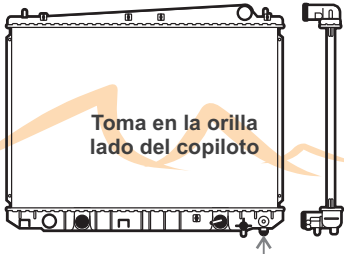
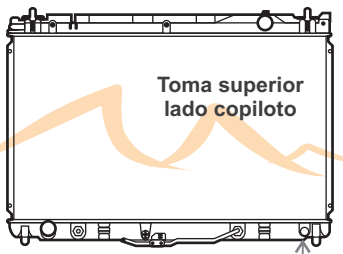
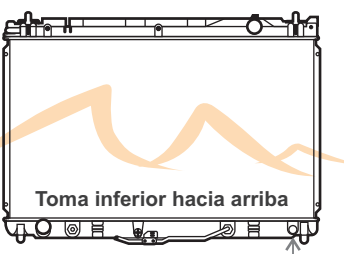
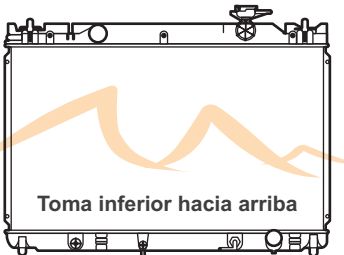
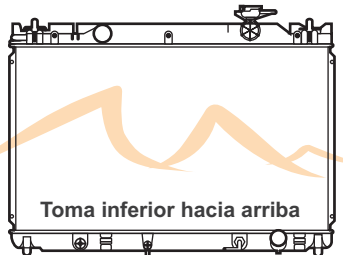
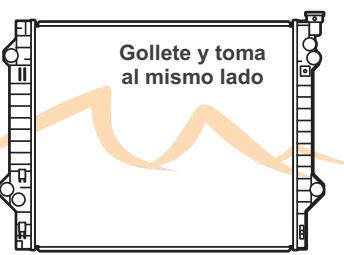
1998 DPI	TOYOTA	2004 DPI	TOYOTA	2090 DPI	TOYOTA
4 RUNNER 96-02		CAMRY 97-01		T-100 94-98	
L4 2.7 V6 3.4		V6 3.0		L4 2.7 V6 3.0/3.4	
PANAL: 22 5/8" X 25 1/4" X 1" (26 mm) CS: 1 7/8" X 26" ENTRADA: 1 3/8" CI: 1 7/8" X 26" SALIDA: 1 3/8" EDA: 14 3/4" EDAM: NO		PANAL: 15 3/4" X 29" X 1 1/4" (32 mm) CS: 1 15/16" X 29 3/4" ENTRADA: 1 3/8" CI: 1 15/16" X 29 3/4" SALIDA: 1 3/8" EDA: NO EDAM: NO NOTAS: 26 MT		PANAL: 17 5/8" X 27 5/8" X 1 1/4" (32 mm) CS: 1 15/16" X 28 3/16" ENTRADA: 1 3/8" CI: 1 15/16" X 28 3/16" SALIDA: 1 3/8" EDA: SI EDAM: NO NOTAS: Puede usar 1512	
037		038		039	
2198 DPI	TOYOTA/GEO	2292 DPI	TOYOTA	2304 DPI	TOYOTA
COROLLA/PRIZM 98-02		RAV-4 98-00		ECHO 00-05	
L4 1.6		L4 2.0		L4 1.5	
PANAL: 13 3/4" X 25 1/4" X 5/8" (16 mm) CS: 1 7/8" X 25 11/16" ENTRADA: 1 1/4" CI: 1 7/8" X 25 11/16" SALIDA: 1 1/4" EDA: 8 7/8" EDAM: NO		PANAL: 13 3/4" X 27 3/8" X 1" CAB. SUP.: 1 7/8" X 28 5/16" CAB. INF.: 1 7/8" X 28 5/16" Enfriador: NO		PANAL: 13 11/16" X 18 13/16" X 5/8" CS: 1 5/16" X 19 15/16" ENTRADA: 1 1/4" CI: 1 9/16" X 19 15/16" SALIDA: 1 1/4" EDA: SI 8 7/8" EDAM: NO	
040		041		042	
2305 DPI	TOYOTA	2320 DPI	TOYOTA	2321 DPI	TOYOTA
A/T YARIS 1300 00-04		A/T TUNDRA 00-06		A/T TUNDRA 00-06	
1.3		V6 3.4/4.0		V8 4.7	
PANAL: 13 3/4" X 19 3/16" X 5/8" (16 mm) CS: 1 5/16" X 19 15/16" ENTRADA: 1 1/4" CI: 1 9/16" X 19 15/16" SALIDA: 1 1/4" EDA: 8 7/8" EDAM: NO		PANAL: 21 5/8" X 28 5/16" X 1 7/16" (36 mm) CS: 2 3/16" X 28 1/4" ENTRADA: 1 5/16" CI: 2 3/16" X 28 1/4" SALIDA: 1 1/2" EDA: 14 3/4" EDAM: NO		PANAL: 22 5/8" X 28 5/16" X 1 7/16" (36 mm) CS: 2 3/16" X 28 1/4" ENTRADA: 1 1/2" CI: 2 3/16" X 28 1/4" SALIDA: 1 1/2" EDA: 14 3/4" EDAM: NO	
043		044		045	

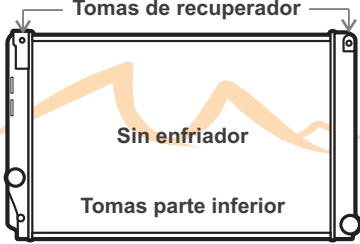
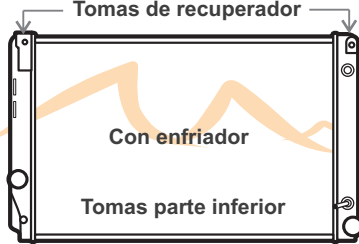
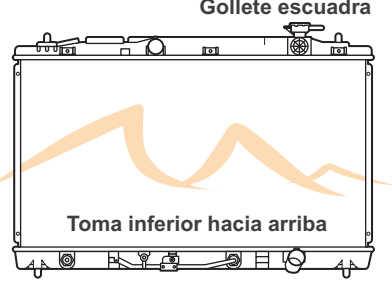
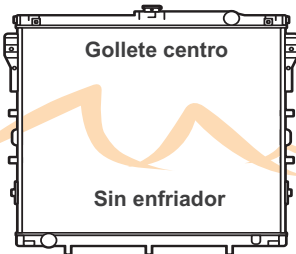
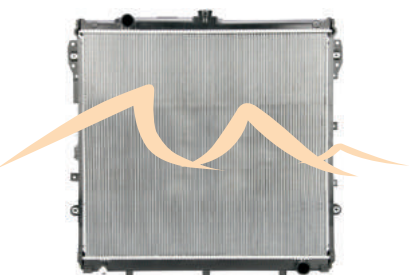
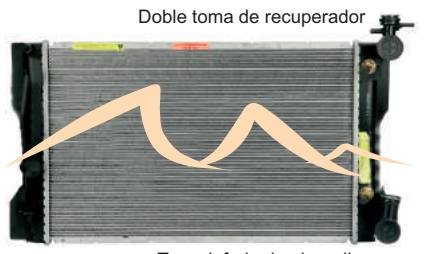
<p>2322 DPI TOYOTA</p>  <p>Similar al 2320 pero sin enfriador</p> <p>M/T TUNDRA 00-04 V6 3.4/4.0</p> <p>PANAL: 21 5/8" X 28 5/16" X 1 7/16" (36 mm) CS: 2 3/16" X 28 1/4" ENTRADA: 1 5/16" CI: 2 3/16" X 28 1/4" SALIDA: 1 1/2" EDA: NO EDAM: NO</p> <p>046</p>	<p>2403 DPI TOYOTA</p>  <p>Toma interior en escuadra</p> <p>RAV-4 01-05 L4 2.0/2.4</p> <p>DPI 2403</p> <p>PANAL: 14 3/4" X 29" X 1" CAB. SUP.: 1 7/16" X 29 7/8" CAB. INF.: 1 7/16" X 29 7/8" Enfriador: NO</p> <p>TOMAS: ENTRADA: 1 3/8" SALIDA: 1 5/16"</p> <p>047</p>	<p>2411 DPI TOYOTA</p>  <p>Gollete en escuadra y toma al mismo lado</p> <p>Base sensor</p> <p>RAV4 01-03 L4 2.0</p> <p>PANAL: 14 3/4" X 30" X 1" (26mm) CS: 1 1/2" X 30 ENTRADA: 1 5/16" CI: 1 1/2" X 30 SALIDA: 1 5/16" EDA: 15 3/8" Concéntrico EDAM: NO</p> <p>048</p>
<p>2427 DPI TOYOTA</p>  <p>Toma en la orilla lado del copiloto</p> <p>Base sensor</p> <p>SIENNA 01-03 V6 3.0</p> <p>PANAL: 17 11/16" X 28 1/4" X 1" (26 mm) CS: 2 1/16" X 29 3/8" ENTRADA: 1 3/8" CI: 2 1/16" X 29 3/8" SALIDA: 1 3/8" EDA: 14 3/4" EDAM: NO</p> <p>049</p>	<p>2434 DPI TOYOTA/LEXUS</p>  <p>Toma superior lado copiloto</p> <p>Base sensor</p> <p>CAMRY 02-06/SOLARA 02-08/ES330 02-06 V6 3.0/3.3</p> <p>PANAL: 15 3/4" X 28 11/16" X 1" (26 mm) CS: 1 7/8" X 29 3/4" ENTRADA: 1 5/16" CI: 1 7/8" X 29 3/4" SALIDA: 1 5/16" EDA: 14 3/4" EDAM: NO</p> <p>050</p>	<p>2435 DPI TOYOTA/LEXUS</p>  <p>Toma inferior hacia arriba</p> <p>Base sensor</p> <p>CAMRY 02-06/ES300 02-03 V6 3.0/3.3</p> <p>PANAL: 15 3/4" X 30" X 5/8" (16 mm) CS: 1 7/8" X 29 3/4" ENTRADA: 1 5/16" CI: 1 7/8" X 29 3/4" SALIDA: 1 5/16" EDA: 14 3/4" EDAM: NO</p> <p>051</p>
<p>2436 DPI TOYOTA</p>  <p>Gollete escuadra</p> <p>Toma inferior hacia arriba</p> <p>SOLARA 04-08/CAMRY 02-06 L4 2.4</p> <p>PANAL: 15 3/4" X 30" X 1" (26 mm) CS: 1 7/8" X 29 3/4" ENTRADA: 1 5/16" CI: 1 7/8" X 29 3/4" SALIDA: 1 5/16" EDA: SI Concéntrico</p> <p>052</p>	<p>2437 DPI TOYOTA</p>  <p>Gollete escuadra</p> <p>Toma inferior hacia arriba</p> <p>SOLARA 04-08/CAMRY 02-06 L4 2.4</p> <p>PANAL: 15 3/4" X 29 1/16" X 5/8" (16 mm) CS: 1 5/16" X 29 3/4" ENTRADA: 1 5/16" CI: 1 7/8" X 29 3/4" SALIDA: 1 5/16" EDA: 14 3/4" EDAM: NO</p> <p>053</p>	<p>2802 DPI TOYOTA</p>  <p>Gollete y toma al mismo lado</p> <p>TACOMA 05-13 L4 2.7 V6 4.0</p> <p>PANAL: 25 9/16" X 21 1/8" X 7/8" (22 mm) CS: 1 7/8" X 22 1/16" ENTRADA: 1 3/8" CI: 1 7/8" X 22 1/16" SALIDA: 1 3/8" EDA: SI</p> <p>CONDENSADOR: AC3393</p> <p>054</p>

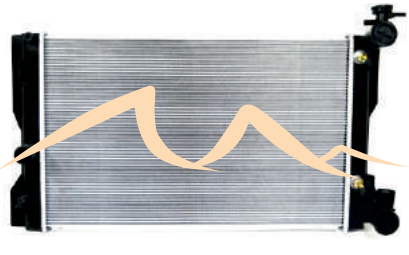
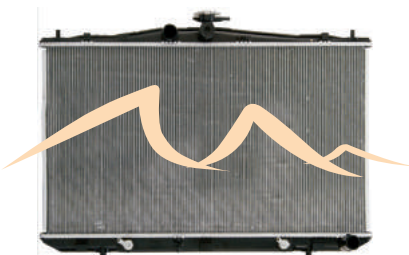
<p>2891 DPI TOYOTA</p>  <p>Tomas de recuperador</p> <p>Sin enfriador</p> <p>Tomas parte inferior</p> <p>M/T RAV4 06-11 L4 2.4/2.5</p> <p>PANAL: 26 3/8" X 15 13/16" X 5/8" (16 mm) CS: 1 9/16" X 16 3/4" ENTRADA: 1 1/2" CI: 1 9/16" X 16 3/4" SALIDA: 1 1/2"</p> <p>CONDENSADOR: AC3575 055</p>	<p>2892 DPI TOYOTA</p>  <p>Tomas de recuperador</p> <p>Con enfriador</p> <p>Tomas parte inferior</p> <p>A/T RAV4 06-13 L4 2.4/2.5 V6 3.5</p> <p>PANAL: 26 3/8" X 15 13/16" X 5/8" (16 mm) CS: 1 9/16" X 16 3/4" ENTRADA: 1 1/2" CI: 1 9/16" X 16 3/4" SALIDA: 1 1/2" EDA: SI</p> <p>CONDENSADOR: AC3575 056</p>	<p>2919 DPI TOYOTA/LEXUS</p>  <p>Gollete escuadra</p> <p>Toma inferior hacia arriba</p> <p>ES350/VENZA 07-12/09-13 V6 3.5</p> <p>PANAL: 15 3/4" X 30 1/8" X 1" (26 mm) CS: 1 9/16" X 31 1/2" ENTRADA: 1 3/8" CI: 1 9/16" X 31 1/2" SALIDA: 1 3/8" EDA: 14 3/4" EDAM: NO MAQ: 3.5 V6 057</p>
<p>2992 DPI TOYOTA</p>  <p>Gollete centro</p> <p>Sin enfriador</p> <p>M/T TUNDRA 07-13 V6 4.0 V8 4.7</p> <p>PANAL: 25 9/16" X 27 15/16" X 5/8" (16 mm) CS: 1 7/8" X 29" ENTRADA: 1 3/8" CI: 1 7/8" X 29" SALIDA: 1 3/8" EDA: NO</p> <p>058</p>	<p>2994 DPI TOYOTA</p>  <p>SEQUOIA/TUNDRA 07-14 V8 4.6/5.7</p> <p>PANAL: 25 9/16" X 27 11/16" X 1 1/4" CAB. SUP.: 2 3/16" X 29" CAB. INF.: 2 3/16" X 29" Enfriador: NO</p> <p>TOMAS: ENTRADA: 1 1/2" SALIDA: 1 1/2"</p> <p>059</p>	<p>13049 DPI TOYOTA/PONTIAC</p>  <p>Doble toma de recuperador</p> <p>Toma inferior hacia arriba</p> <p>COROLLA/MATRIX/VIBE 09-13 L4 2.4</p> <p>PANAL: 23 11/16" X 14 7/8" X 1" (26) CS: 1 7/8" X 15 3/4" ENTRADA: 1 3/8" CI: 1 7/8" X 15 3/4" SALIDA: 1 3/8" EDA: SI CONCENTRICO</p> <p>060</p>
<p>13076 DPI TOYOTA</p>  <p>SIENNA 07-10 V6 3.5</p> <p>PANAL: 26 9/16" X 18 13/16" X 7/8" CAB. SUP.: 1 9/16" X 19 15/16" CAB. INF.: 1 9/16" X 19 15/16" Enfriador: SI</p> <p>TOMAS: ENTRADA: 1 9/16" SALIDA: 1 9/16"</p> <p>CONDENSADOR: AC3284 061</p>	<p>13106 DPI TOYOTA</p>  <p>COROLLA/MATRIX 09-14 L4 1.8</p> <p>PANAL: 23 5/8" X 14 9/16" X 15 3/4" CS: 1 5/16" X 15 3/4" ENTRADA: 1 3/8" CI: 1 9/16" X 15 3/4" SALIDA: 1 3/8" EDA: SI 9 13/16" Concentrico EDAM: NO</p> <p>062</p>	<p>13117 DPI TOYOTA</p>  <p>SIENNA 11-15 V6 3.5</p> <p>PANAL: 17 11/16" X 30 3/16" X 5/8" CAB. SUP.: 1 7/8" X 31 1/4" CAB. INF.: 1 7/8" X 31 1/4" Enfriador: SI</p> <p>TOMAS: ENTRADA: 1 5/16" SALIDA: 1 5/16"</p> <p>CONDENSADOR: AC3869 063</p>

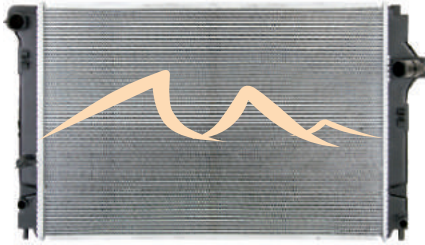
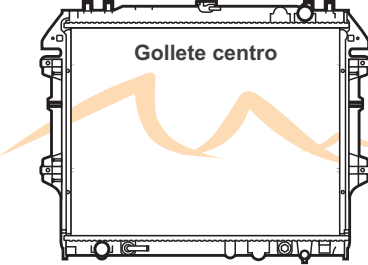
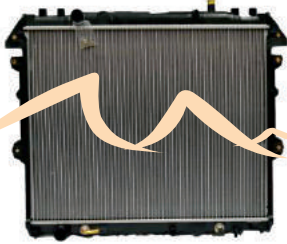
13319 DPI	TOYOTA	LHRP189-26AT	TOYOTA	LHRP234	TOYOTA
 <p>Toma hacia adentro</p>		 <p>Gollete centro</p>		 <p>Tomas lineales</p> <p>Tomas mismo lado de piloto</p>	
PRIUS C 12-16		A/T HILUX 05-08		HILUX 2004	
L4 1.5		L4 2.7		L4 2.5	
PANAL: 23 7/16" X 15 13/16" X 5/8" CAB. SUP.: 1 5/16" X 16 7/8" CAB. INF.: 1 5/16" X 16 7/8" Enfriador: NO		PANAL: 19 11/16" X 25 1/2" X 1" (26 mm) CS: 1 7/8" X 26 3/4" CI: 1 7/8" X 26 3/4" EDA: SI EDAM:		PANAL: 20 5/8" X 25 1/2" X 1 1/4" (32mm) CS: 1 7/8" X 26 3/4" CI: 1 7/8" X 26 3/4" EDA: SI	
TOMAS: ENTRADA: 1 1/4" SALIDA: 1 1/4"		ENTRADA: 1 3/8" SALIDA: 1 3/8"		ENTRADA: 1 3/8" SALIDA: 1 1/2"	
064		065		066	

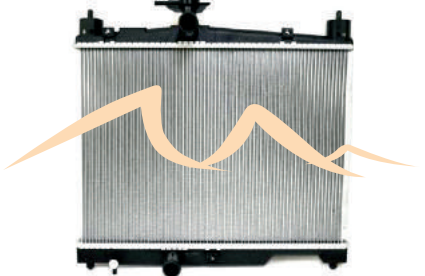
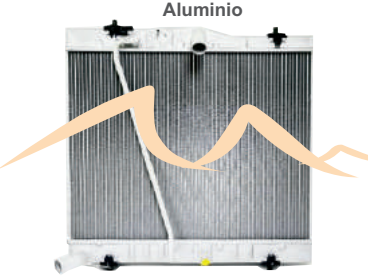
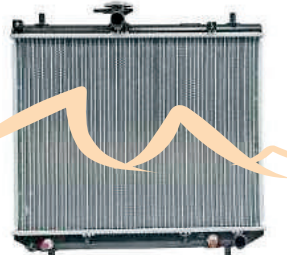
LHRP373	TOYOTA	LHRP515	TOYOTA	LHRP710-2	TOYOTA
		 <p>Aluminio</p>		 <p>Toma y gollete al centro</p>	
YARIS 99-08		HI-ACE 06-09		AVANZA 08-12	
L4 1.0/1.3		L4 2.7		L4 1.5	
PANAL: 13 25/32" X 18 13/16" X 5/8" CS: 1 5/16" X 19 15/16" CI: 1 9/16" X 19 15/16" EDA: NO EDAM: NO		PANAL: 20 1/16" X 25 15/16" X 1 7/16" CS: 2 3/8" X 26 13/16" CI: 2 3/8" X 26 13/16" EDA: NO EDAM: NO		PANAL: 16 13/16" X 21 5/8" X 1" CAB. SUP.: 1 7/8" X 22 7/8" CAB. INF.: 1 7/8" X 22 7/8" Enfriador: SI	
ENTRADA: 1 1/4" SALIDA: 1 1/4"		ENTRADA: 1 1/2" SALIDA: 1 1/2"		TOMAS: ENTRADA: 1 5/16" SALIDA: 1 5/16"	
067		068		069	

Escanea nuestro código QR con tu smartphone

Descarga la aplicación desde tu Smartphone en: www.2dscan.com

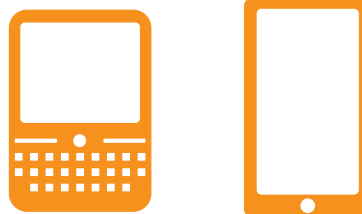



NOTAS

Lined area for notes, featuring a large orange graphic at the bottom.



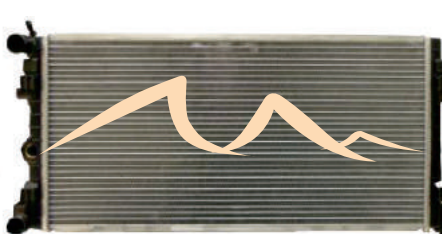
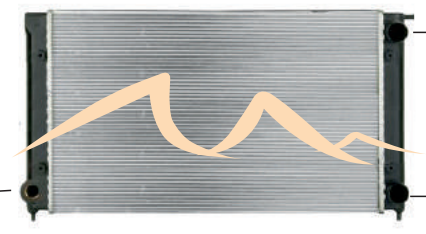
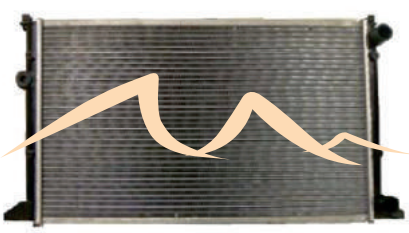
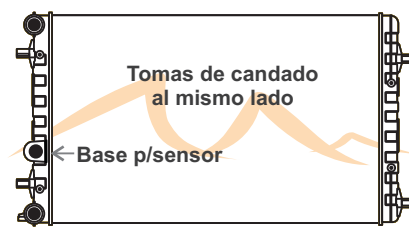
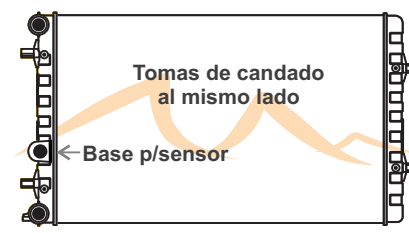

Radiadores

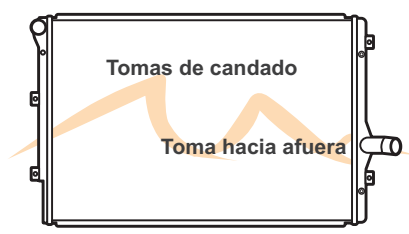
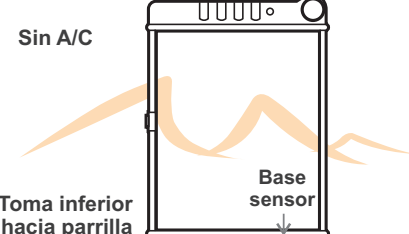
PHAR

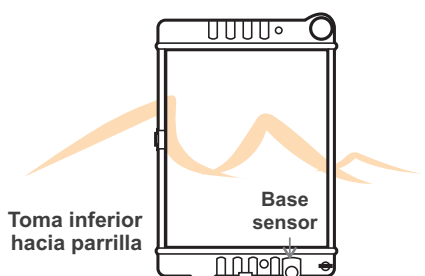
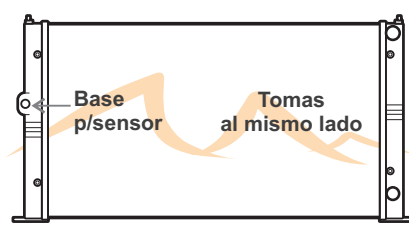
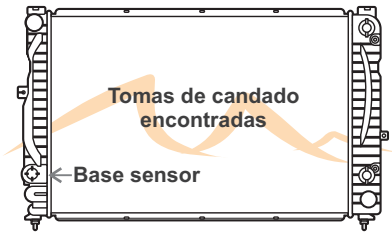
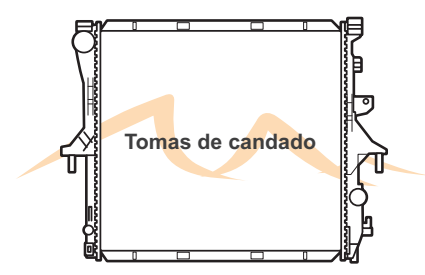
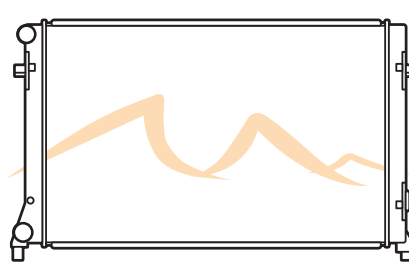
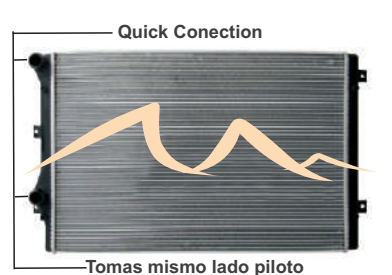
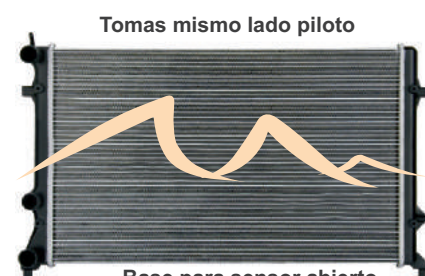
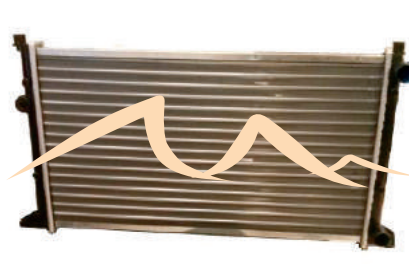
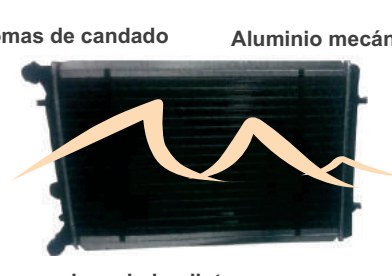
- **VOLKSWAGEN**
- **VOLVO**

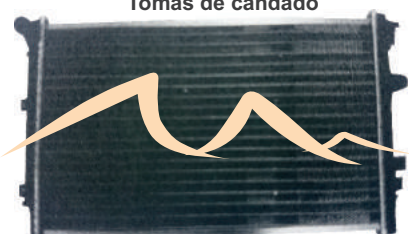
<p>A020-28N AUDI/SEAT/VW</p>  <p>Toma de candado lado piloto</p> <p>A3/LEON/TOLEDO/GOLF 05 L4 1.4/1.9/2.0</p> <p>PANAL: 25 1/2" X 15 5/8" X 1 1/8" CAB. SUP.: 1 11/16" X 16 3/8" CAB. INF.: 1 11/16" X 16 3/8" ENF. TRANS.: NO ENF. MOTOR: NO</p> <p>TOMAS: ENTRADA: 1 5/16" SALIDA: 1 5/16"</p> <p>001</p>	<p>A025-28N SEAT/AUDI/VW</p>  <p>IBIZA 02-10/A1 11-12/POLO 13-14/VENTO 14-15 L4 1.8/1.9/1.6</p> <p>PANAL: 25 1/2" X 12 3/8" X 1 1/8" CS: 1 15/16" X 13 3/8" CI: 1 15/16" X 13 3/8"</p> <p>ENFRIADOR: NO</p> <p>ENTRADA: 1 1/4" SALIDA: 1 1/4"</p> <p>002</p>	<p>A0837-28N VOLKSWAGEN</p>  <p>Base sensor Tomas mismo lado copiloto</p> <p>JETTA 80-92 / GOLF 80-92 L4 1.6/1.7/1.8/2.0</p> <p>5799 PHAR</p> <p>PANAL: 20 9/16" X 11 31/32" X 1 1/8" CS: 1 7/8" X 12 11/16" CI: 1 7/8" X 12 11/16"</p> <p>ENFRIADOR: NO</p> <p>ENTRADA: 1 1/4" SALIDA: 1 1/4"</p> <p>EDAM: NO</p> <p>003</p>
<p>A1557-28N VOLKSWAGEN</p>  <p>GOLF 93-98/CABRIO 95-02/JETTA 93-02 6024 PHAR L4 1.8/1.9/2.0</p> <p>PANAL: 24 5/8" X 13 31/32" X 1 1/8" CS: 1 7/8" X 14 7/8" CI: 1 7/8" X 14 7/8"</p> <p>ENFRIADOR: NO</p> <p>004</p>	<p>A2241-28N VOLKSWAGEN</p>  <p>Tomas de candado al mismo lado</p> <p>Base p/sensor</p> <p>BEETLE 98-11 DPI 2241 / 7029 PHAR L4 1.8/1.9/2.0 L5 2.5</p> <p>PANAL: 25 1/2" X 14 7/8" X 1 1/8" CS: 2" X 15" CI: 2" X 15"</p> <p>ENFRIADOR: NO</p> <p>ENTRADA: 1 1/4" SALIDA: 1 1/4"</p> <p>005</p>	<p>A2265-28N VOLKSWAGEN/AUDI</p>  <p>Tomas de candado al mismo lado</p> <p>Base p/sensor</p> <p>JETTA/GOLF 00-10/TT-QUATRO 00-06 DPI 2265 / 7005 PHAR L4 1.8/1.9/2.0 V6 1.4/2.8/3.2</p> <p>PANAL: 25 5/16" X 16 1/2" X 1 1/8" (28 mm) CS: 1 5/8" X 16 5/16" CI: 1 5/8" X 16 5/16"</p> <p>ENFRIADOR: NO</p> <p>ENTRADA: 1 1/4" SALIDA: 1 1/4"</p> <p>006</p>
<p>A2756-44N AUDI/PORSCHE/VW</p>  <p>Tomas de candado</p> <p>Q7 06-15/CAYENNE 03-10/TOUAREG 04-10 V6 3.0/3.2/3.6 / V8 4.1/4.2/4.5/4.8 / V10 4.9/5.0</p> <p>PANAL: 28" X 21 1/4" X 1 3/4" CAB. SUP.: 2 3/8" X 22 7/8" CAB. INF.: 2 3/8" X 22 7/8"</p> <p>ENF. TRANS.: NO</p> <p>TOMAS: ENTRADA: 1 1/2" SALIDA: 1 1/2"</p> <p>CONDENSADOR: AC3294</p> <p>007</p>	<p>A2822-28N VOLKSWAGEN/AUDI</p>  <p>Tomas de candado</p> <p>Toma hacia afuera</p> <p>JETTA 06-13/TT-QUATRO 06-13/PASSAT 06-08/A3 DPI 2822 L4 1.8/2.0</p> <p>PANAL: 25 5/8" X 18 1/4" X 1 1/8" (25 mm) CS: 2" X 18 13/16" CI: 2" X 18 13/16"</p> <p>ENFRIADOR: NO</p> <p>ENTRADA: 1 1/4" SALIDA: 1 1/4"</p> <p>CONDENSADOR: AC3255/AC3493/AC3889</p> <p>008</p>	<p>A6040-28N VOLKSWAGEN</p>  <p>Sin A/C</p> <p>Toma inferior hacia parrilla</p> <p>Base sensor</p> <p>POINTER 98-10 6040 PHAR L4 1.8/2.0</p> <p>PANAL: 18 1/2" X 12" X 1 1/8" CS: 2 1/4" X 12 7/8" CI: 2 1/4" X 12 7/8"</p> <p>ENFRIADOR: NO</p> <p>ENTRADA: 1 1/4" SALIDA: 1 1/4"</p> <p>009</p>

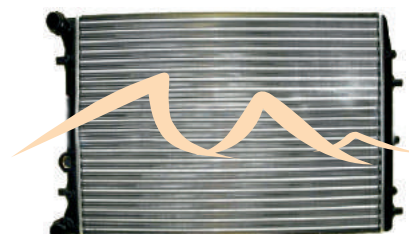
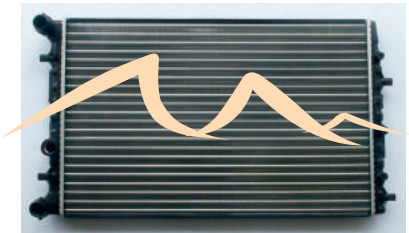
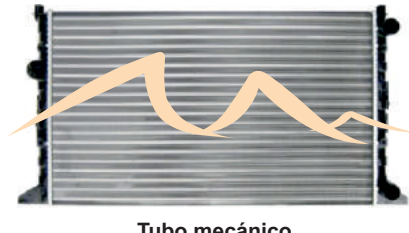
<p>A6040-44N VOLKSWAGEN</p>  <p>Toma inferior hacia parrilla</p> <p>Base sensor</p> <p>POINTER 98-08</p> <p>6040 PHAR L4 1.8/2.0</p> <p>PANAL: 18 1/2" X 12" X 1 3/4" CS: 2 1/4" X 12 7/8" CI: 2 1/4" X 12 7/8" ENFRIADOR: NO</p> <p>ENTRADA: 1 1/4" SALIDA: 1 1/4"</p> <p>010</p>	<p>1557 DPI VOLKSWAGEN</p>  <p>Base p/sensor</p> <p>Tomas al mismo lado</p> <p>GOLF/GTI/JETTA/CABRIO 93-98</p> <p>6024 PHAR L4 1.8/1.9/2.0</p> <p>PANAL: 24 3/4" X 14 7/8" X 1 1/4" (32 mm) CS: 1 7/8" X 12 3/4" CI: 1 7/8" X 12 3/4" EDA: NO</p> <p>ENTRADA: 1 1/4" SALIDA: 1 1/4"</p> <p>011</p>	<p>2648 DPI VOLKSWAGEN/AUDI</p>  <p>Tomas de candado encontradas</p> <p>Base sensor</p> <p>S4/QUATTRO/PASSAT/A6 98-04</p> <p>L4 1.8 / V6 2.7/2.8</p> <p>PANAL: 24 7/8" X 15 11/16" X 1 3/16" CS: 1 9/16" X 16 9/16" CI: 1 9/16" X 16 9/16" EDA: 11 3/4" Concéntrico EDAM: NO</p> <p>ENTRADA: 1 3/8" SALIDA: 1 3/8"</p> <p>012</p>
<p>2872 DPI VOLKSWAGEN</p>  <p>Tomas de candado</p> <p>TOUAREG 05-08</p> <p>V10 5.0 TDi</p> <p>PANAL: 27 15/16" X 21 5/8" X 1 11/16" CS: 2 1/2" X 22 3/16" CI: 2 1/2" X 22 3/16" EDA: NO</p> <p>ENTRADA: 1 1/2" SALIDA: 1 1/2"</p> <p>013</p>	<p>2995 DPI VOLKSWAGEN/AUDI</p>  <p>JETTA 05-10/GOLF 10-13/TT-QUATRO 07-08</p> <p>L4 2.0 L5 2.5 V6 3.2</p> <p>PANAL: 25 9/16" X 15 3/4" X 1 5/16" CS: 2" X 16 13/16" CI: 2" X 16 13/16" EDA: NO EDAM: NO CONDENSADOR: AC3255</p> <p>ENTRADA: 1 1/4" SALIDA: 1 1/4"</p> <p>014</p>	<p>13212 DPI AUDI/VOLKSWAGEN</p>  <p>Quick Conection</p> <p>Tomas mismo lado piloto</p> <p>PASSAT/JETTA/BEETLE EOS/TT/QUATRO 09-15</p> <p>L4 1.4/1.8/2.0</p> <p>PANAL: 25 5/8" X 17 1/2" X 1 1/4" (32mm) CAB. SUP.: 1 13/16" X 17 1/8" CAB. INF.: 1 13/16" X 17 1/8" ENF. TRANS.: NO ENF. MOTOR: NO CONDENSADOR: AC3255/AC3493</p> <p>TOMAS ENTRADA: 1 1/4" SALIDA: 1 1/4"</p> <p>015</p>
<p>13215 DPI VOLKSWAGEN</p>  <p>Tomas mismo lado piloto</p> <p>Base para sensor abierto</p> <p>JETTA BICENTENARIO/GOLF/BEETLE 11-15</p> <p>L4 2.0/L5 2.5</p> <p>PANAL: 25 1/2" X 16 1/8" X 1" (26mm) CAB. SUP.: 1 11/16" X 16 1/4" CAB. INF.: 1 11/16" X 16 1/4" ENF. TRANS.: NO ENF. MOTOR: NO CONDENSADOR: AC3889</p> <p>TOMAS ENTRADA: 1 3/8" SALIDA: 1 3/8"</p> <p>016</p>	<p>M1557-26N VOLKSWAGEN</p>  <p>JETTA 93-02/GOLF 93-98/CABRIO 95-02/CABRIOLET 92-93</p> <p>6024 PHAR L4 1.8/1.9/2.0</p> <p>PANAL: 24 5/8" X 14 3/16" X 1" CS: 1 7/8" X 14 7/8" CI: 1 7/8" X 14 7/8" EDA: NO</p> <p>ENTRADA: 1 1/4" SALIDA: 1 1/4"</p> <p>017</p>	<p>M2265-26N AUDI/VOLKSWAGEN</p>  <p>Tomas de candado</p> <p>Aluminio mecánico</p> <p>Tomas mismo lado piloto</p> <p>JETTA/GOLF 00-10/TT/QUATRO 00-06</p> <p>L4 1.8/1.9/2.0 / V6 1.4/2.8/3.2</p> <p>PANAL: 25 1/2" X 14 15/16" X 1" CAB. SUP.: 16 15/16" X 1 5/8" CAB. INF.: 16 15/16" X 1 5/8" ENF. TRANS.: NO</p> <p>TOMAS ENTRADA: 1 1/4" SALIDA: 1 1/4"</p> <p>018</p>

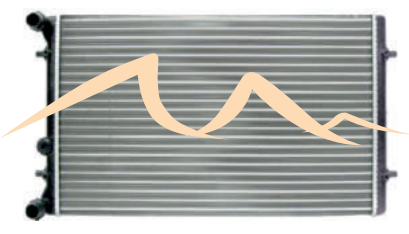
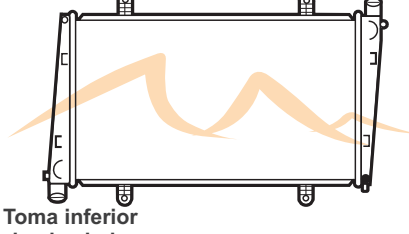
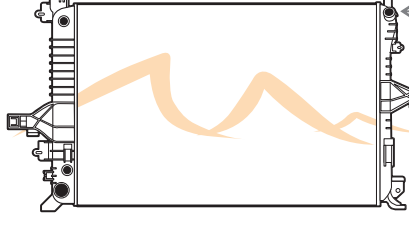
<p>M13272-26N VOLKSWAGEN LHRP596</p> <p>Tomas de candado</p>  <p>Tubo mecánico</p> <p>Tiguan 10-15</p> <p>DPI 13272 L4 1.4/2.0</p> <p>PANAL: 25 5/8" X 16 5/8" X 1" CAB. SUP.: 1 5/8" X 17 3/4" CAB. INF.: 1 5/8" X 17 3/4" ENF. TRANS.: NO ENF. MOTOR: NO</p> <p>TOMAS: ENTRADA: 1 1/4" SALIDA: 1 1/4"</p> <p>019</p>	<p>LHRP596 VOLKSWAGEN LHRP487-2</p> <p>Tomas de candado</p>  <p>Tomas de candado</p> <p>TIGUAN 07-14</p> <p>DPI 13272 L4 1.4/2.0</p> <p>PANAL: 25 9/16" X 17 1/2" X 1" (26mm) CS: 1 7/8" X 17 7/8" CI: 1 7/8" X 17 7/8" EDA: NO</p> <p>ENTRADA: 1 1/4" SALIDA: 1 1/4"</p> <p>020</p>	<p>LHRP487-2 VOLKSWAGEN</p>  <p>LUPO/POLO/GOL/CROSS FOX 05-12</p> <p>L4 1.2/1.4</p> <p>PANAL: 16 13/16" X 16 1/16" X 7/8" CAB. SUP.: 1 11/16" X 16 5/16" CAB. INF.: 1 11/16" X 16 5/16" Enfriador: NO</p> <p>TOMAS: ENTRADA: 1 1/4" SALIDA: 1 1/4"</p> <p>021</p>
<p>LHRP488-1 VOLKSWAGEN</p> <p>Tomas de candado</p>  <p>GOL/LUPO/CROSS FOX 05-09</p> <p>L4 1.4/1.6/1.8/1.9</p> <p>PANAL: 24 7/8" X 16 1/8" X 7/8" CAB. SUP.: 1 5/8" X 16 5/8" CAB. INF.: 1 5/8" X 16 5/8" Enfriador: NO</p> <p>TOMAS: ENTRADA: 1 1/4" SALIDA: 1 1/4"</p> <p>022</p>	<p>1557-26N VOLKSWAGEN</p> <p>ALUMINIO MECÁNICO</p>  <p>Tubo mecánico</p> <p>GOLF 93-98/JETTA 93-02/CABRIO 95-02/CABRIOLET 92-93</p> <p>6024 PHAR L4 1.8/1.9/2.0</p> <p>PANAL: 21 5/8" X 14 3/16" X 1" CS: 14 7/8" X 1 7/8" CI: 14 7/8" X 1 7/8" ENFRIADOR: NO</p> <p>ENTRADA: 1 1/4" SALIDA: 1 1/4"</p> <p>023</p>	<p>1557-32M VOLKSWAGEN</p> <p>ALUMINIO MECÁNICO</p>  <p>GOLF/JETTA 93-99</p> <p>6024 PHAR / VW 0020 L4 1.8/1.9/2.0</p> <p>PANAL: 21 5/8" X 14 7/8" X 1 1/4" CS: 14 7/8" X 2" CI: 14 7/8" X 2" ENFRIADOR: NO</p> <p>ENTRADA: 1 1/4" SALIDA: 1 1/4"</p> <p>024</p>
<p>2265-24M VOLKSWAGEN</p> <p>ALUMINIO MECÁNICO</p>  <p>GOLF/JETTA 99-05</p> <p>7005 PHAR / VW 0030 L4 1.8/1.9/2.0 V6 2.8</p> <p>PANAL: 23 5/8" X 18" X 1 1/4" (32 mm) CS: 18 3/4" X 1 11/16" CI: 18 3/4" X 1 11/16" EDA: NO</p> <p>ENTRADA: 1 3/8" SALIDA: 1 3/8"</p> <p>025</p>	<p>2400 DPI VOLVO</p> <p>Toma superior hacia arriba</p>  <p>Toma inferior hacia abajo</p> <p>S40/V40 00-04</p> <p>7026 PHAR L4 1.9</p> <p>PANAL: 24 1/2" X 12 13/16" X 1" (26 mm) CS: 1 7/8" X 14" CI: 1 7/8" X 14" EDA: 11" Concéntrico EDAM: NO</p> <p>ENTRADA: 1 1/4" SALIDA: 1 1/4"</p> <p>026</p>	<p>2805 DPI VOLVO</p> <p>Toma superior hacia arriba</p>  <p>S60/S80 01-06/99-04</p> <p>L5 2.4/2.5 L6 2.8/2.9</p> <p>PANAL: 24 3/8" X 16 9/16" X 1 9/16" CS: 2 5/16" X 16 3/8" CI: 2 5/16" X 16 3/8" EDA: SI</p> <p>ENTRADA: 1 1/2" SALIDA: 1 1/2"</p> <p>027</p>

2878 DPI

VOLVO

13315 DPI

VOLVO

ATE8075-44P5

MACK/VOLVO

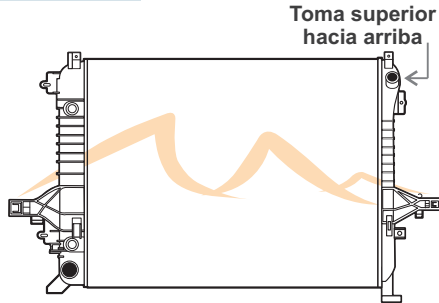

Toma superior
hacia arriba

S80 2011/XC90 03-13

L5 2.5 L6 2.9/3.2 V8 4.4

PANAL: 24 3/8" X 21 1/8" X 1 3/8"
CS: 2 3/16" X 21 7/8"
CI: 2 3/16" X 21 7/8"
EDA: SI Concéntrico

ENTRADA: 1 1/2"
SALIDA: 1 1/2"

028

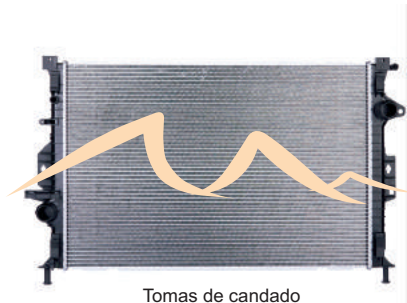

Tomas de candado

S60/S80/V60/V70/XC60/XC70 08-15

L4 2.0/2.5 / L6 3.0/3.2 / V8 4.4

PANAL: 26 3/8" X 18 3/8" X 1" (26)
CS: 1 5/8" X 18 7/16"
CI: 1 5/8" X 18 7/16"
EDA: NO

ENTRADA: 1 1/2"
SALIDA: 1 1/2"

029

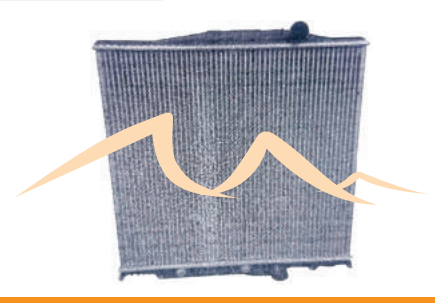

**CNX VISION/VN SERIES AUT 800040,
VOL40, 239311, 80040WF,2001-4605**

PANAL: 43 3/8" X 36 1/2" X 5"
CAB. SUP.: 35 7/8" X 3 3/16"
CAB. INF.: 35 7/8" X 3 3/16"
Enfriador: SI

TOMAS:
ENTRADA: 2 1/2"
SALIDA: 2 1/2"

030

NOTAS

A6205	CASE	A8356	CASE
A-108N	SERIES L 570, 580, 590, RETRO / TRACTOR	A-108N	BACKHOE
PANAL: 18 9/16" X 19 5/8" X 4 1/4" T. ENTRADA: 1 3/4" T. SALIDA: 2 1/4" ENFRIADOR: NO REFERENCIAS: NORTHERN 219952, 4500475T OEMS: 234876A1, 239739A1	ALUMINIO 	PANAL: 21 9/16" X 18 1/32" T. ENTRADA: 4 7/8" X 18 1/8" T. SALIDA: 4 7/8" X 18 1/8" ENFRIADOR: NO REFERENCIAS:	ALUMINIO
001		002	

A8065	FORD / STERLING	A8067	FORD / STERLING FREIGHTLINER
AT-44N	94-97 L/LA/LN/LS/LT8000/LN7000 SERIES	AT-44N	SERIES 95-00/98-07/ SERIES CLASCA/FLD 98-07
PANAL: 34 7/8" X 25" X 1 3/4" T. ENTRADA: 2 1/2" T. SALIDA: 2" ENFRIADOR: NO REFERENCIAS:	ALUMINIO 	PANAL: 35 15/16" X 38 1/2" X 1 3/4" T. ENTRADA: 2 1/2" T. SALIDA: 2 1/2" ENFRIADOR: NO REFERENCIAS:	ALUMINIO
003		004	



A6120	FREIGHTLINER	A8047	FREIGHTLINER
ACTA-44N/ACA-44N	TRACTOCAMIÓN 98-02 CENTURY CLASS COLUMBIA	AT-44N	CENTURY CLASS COLUMBIA 98-02
PANAL: 36" X 30 23/64" T. ENTRADA: 2 1/2" T. SALIDA: 2 1/2" ENFRIADOR: NO REFERENCIAS: 437157TNP	ALUMINIO 	PANAL: 35" X 30" T. ENTRADA: 2 1/2" T. SALIDA: 2 1/2" ENFRIADOR: NO REFERENCIAS:	ALUMINIO
005		006	

A8059	FREIGHTLINER	A8059	FREIGHTLINER
COLUMBIA		COLUMBIA	
<p>ACTS/ACS ACTA-44N/ACA-44N</p> <p>PANAL: 41 15/16" X 31 1/16" T. ENTRADA: 2 1/2" T. SALIDA: 2 1/2" ENFRIADOR: NO REFERENCIAS: 800022 FRE22 239336 SRM8056-F FRE22F</p>		<p>AT-44N</p> <p>PANAL: 41 3/4" X 31 3/8" T. ENTRADA: 2 1/2" T. SALIDA: 2 1/2" ENFRIADOR: NO REFERENCIAS:</p>	
<p>ALUMINIO</p>		<p>ALUMINIO</p>	
CON O SIN CORAZA			
007		008	

A8107	INTERNATIONAL	A8238	FREIGHTLINER/STERLING
SERIES 8100 - SERIES 4900 - 500 SFA		AT-44N	
<p>A-44N</p> <p>PANAL: 35 1/2" X 27 3/4" T. ENTRADA: 2 9/16" T. SALIDA: 2 9/16" ENFRIADOR: NO REFERENCIAS:</p>		<p>PANAL: 45 1/2" X 37 5/8" T. ENTRADA: 2 1/2" T. SALIDA: 2 1/2" ENFRIADOR: YES 758238 REFERENCIAS: 800040 VOL40 239311 80040WF 2001-4605</p>	
<p>ALUMINIO</p>		<p>ALUMINIO</p>	
009		010	

A8453	FREIGHTLINER	A5967	INTERNATIONAL
AT-44N		SERIES 2500, 2600, 8200, 9200, 9300, 9400	
<p>PANAL: 35 3/4" X 37 5/8" T. ENTRADA: 2 1/2" T. SALIDA: 2 1/2" ENFRIADOR: SI 758238 REFERENCIAS:</p>		<p>ACTS-44N</p> <p>PANAL: 41" X 27 3/4" T. ENTRADA: 2 1/2" T. SALIDA: 2 1/2" ENFRIADOR: NO REFERENCIAS:</p>	
<p>ALUMINIO</p>		<p>ALUMINIO</p>	
011		012	

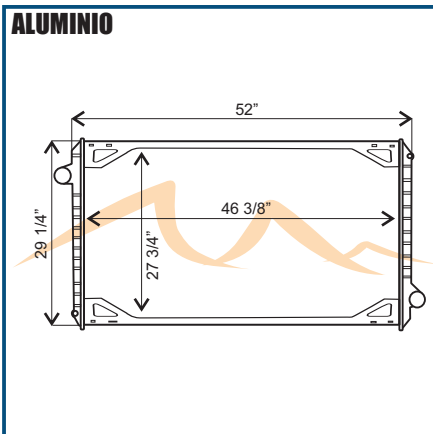
A6125	INTERNATIONAL/NAVISTAR	A8090	INTERNATIONAL
AT-60N	DT-466 02-03/ 4200-4300-4400	AT-60N	08-10/PROSTAR 03-07/ 9900I/9900IX/9200I/9400I/8600
PANAL: 20 1/2" X 24 3/16" X 2 3/8" T. ENTRADA: 2 1/4" T. SALIDA: 2 1/4" ENFRIADOR: NO REFERENCIAS: NO	ALUMINIO 	PANAL: 33 9/16" X 26 1/16" T. ENTRADA: 2 1/2" T. SALIDA: 2 1/2" ENFRIADOR: NO REFERENCIAS: NO	ALUMINIO 
013		014	

A8240	INTERNATIONAL	A8053	MACK
A-44N	SERIES 9800	AT-44N	CX600/CH600/MR600/FMD700/R600ST 1985/1989-05
PANAL: 46 3/4" X 27 3/4" T. ENTRADA: 2 9/16" T. SALIDA: 2 9/16" ENFRIADOR: NO REFERENCIAS: NO	ALUMINIO 	PANAL: 29" X 38 29/32" T. ENTRADA: 2" T. SALIDA: 2 1/2" ENFRIADOR: NO REFERENCIAS: NO	ALUMINIO 
015		016	

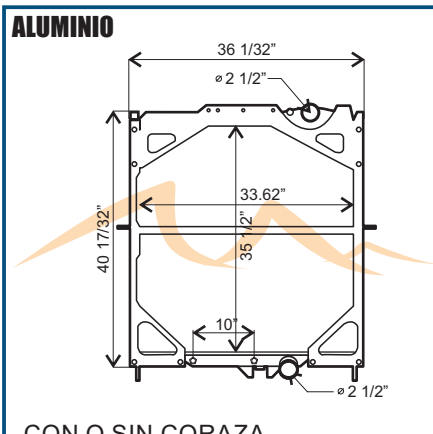
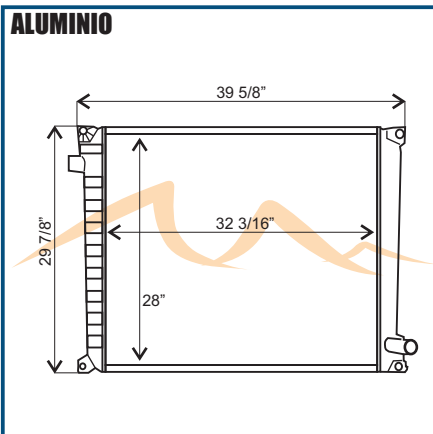
A8075	MACK/VOLVO	A8091	MACK
ACTS-44P5/ACS-44P5 CNX VISION/VN SERIES AUT		ACTA-44N/ACA-44N	CX/ZXN 612
PANAL: 35 1/2" X 33.62" T. ENTRADA: 2 1/2" T. SALIDA: 2 1/2" ENFRIADOR: YES 758075 REFERENCIAS: 800040 VOL40 239311 80040WF 2001-4605	ALUMINIO 	PANAL: 32 3/16" X 28" T. ENTRADA: 2" T. SALIDA: 2" ENFRIADOR: NO REFERENCIAS: NO	ALUMINIO 
017	AT CON O SIN CORAZA	018	

<p>A8197</p> <p>AT-44N</p> <p>PANAL: 27 1/2" X 33 1/2" X 1 3/4" T. ENTRADA: 2" T. SALIDA: 2 1/2" ENFRIADOR: NO REFERENCIAS:</p>	<p>MACK</p> <p>02-08 CV GRANITE/CV 700/500/ 87-04 RD SERIES/ RD 600S/600SX</p> <p>ALUMINIO</p> 	<p>A8062</p> <p>AT-44N</p> <p>PANAL: 34 3/4" X 15 17/32" X 1 3/4" T. ENTRADA: 2 1/4" T. SALIDA: 2 1/4" ENFRIADOR: NO REFERENCIAS:</p>	<p>PETERBILT / KENWORTH</p> <p>SERIES 300 03-07/T300, T800 03-07</p> <p>ALUMINIO</p> 
019		020	

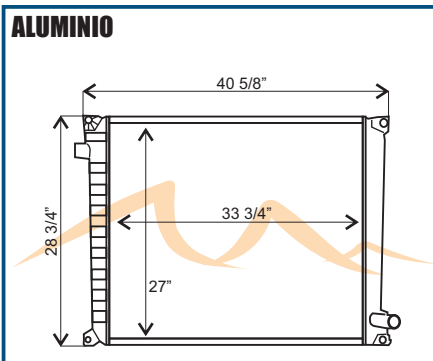
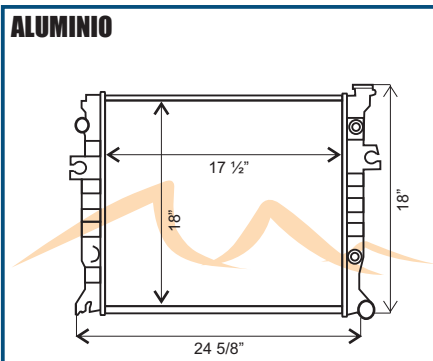
<p>A8039</p> <p>AT-44N</p> <p>PANAL: 33 3/4" X 27" T. ENTRADA: 2 1/4" T. SALIDA: 2 1/4" ENFRIADOR: NO REFERENCIAS:</p>	<p>SCANIA</p> <p>P94/P114/P144/P124 95-03</p> <p>ALUMINIO</p> 	<p>A8042</p> <p>A-44P7</p> <p>PANAL: 17 1/2" X 18" T. ENTRADA: 1 3/8" T. SALIDA: 1 3/8" ENFRIADOR: YES 113-150 REFERENCIAS:</p>	<p>TOYOTA</p> <p>MONTACARGAS</p> <p>ALUMINIO</p> 
021		022	

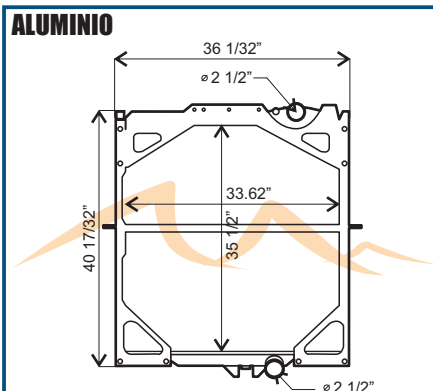
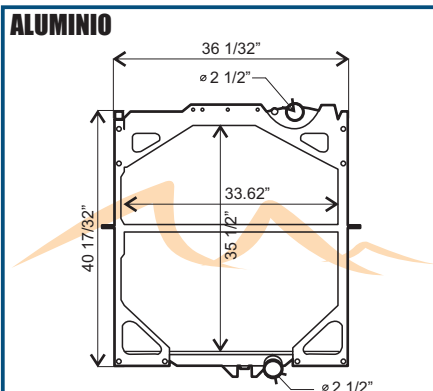
<p>A6003</p> <p>ACTS-60N</p> <p>PANAL: 35 1/2" X 33.62" T. ENTRADA: 2 1/2" T. SALIDA: 2 1/2" ENFRIADOR: NO REFERENCIAS: 8000-09 VOL09 2001-4603 239381 8000-09 WF 239332, VOL09F</p>	<p>VOLVO</p> <p>TRACTOCAMIÓN 00-03</p> <p>ALUMINIO</p> 	<p>A6003</p> <p>ACTS-44N</p> <p>PANAL: 35 1/2" X 33.62" T. ENTRADA: 2 1/2" T. SALIDA: 2 1/2" ENFRIADOR: NO REFERENCIAS: 8000-09 VOL09 2001-4603 239381 8000-09 WF 239332, VOL09F</p>	<p>VOLVO</p> <p>TRACTOCAMIÓN 00-03</p> <p>ALUMINIO</p> 
023	MT	024	MT
			CON CORAZA

A8035

VOLVO

ACTS-44N

AUTOBUS 7550 2003

PANAL:
35 1/2" X 27 1/4"
T. ENTRADA:
2 1/2"
T. SALIDA:
2 1/2"
ENFRIADOR:
NO
REFERENCIAS:

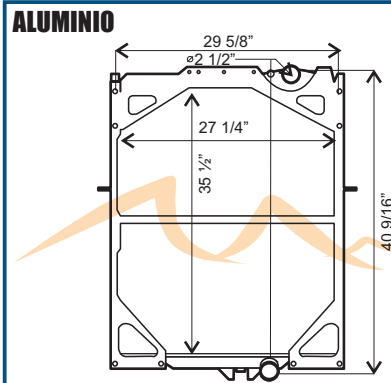

025

MT

WITH FRAME

A8075

VOLVO / MACK

ACTS-44P5/ACS-44P5 CNX VISION/VN SERIES AUT

PANAL:
35 1/2" X 33.62"
T. ENTRADA:
2 1/2"
T. SALIDA:
2 1/2"
ENFRIADOR:
YES 758075
REFERENCIAS:
800040
VOL40
239311
80040WF
2001-4605

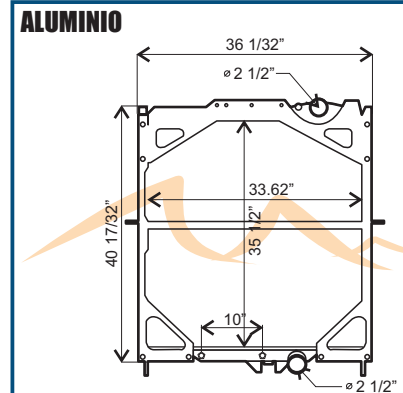

026

AT

CON O SIN CORAZA

A8202

VOLVO

A-44N

AUTOBUS VOL18,800018

PANAL:
28 3/8" X 34"
T. ENTRADA:
2 1/2"
T. SALIDA:
2 1/2"
ENFRIADOR:
NO
REFERENCIAS:

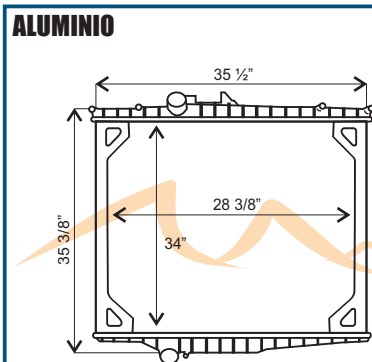

027

AA059-60N

CINCINNATI

AGRICOLA MAQUINA 5.71 GM

PANAL:
24 11/16" X 25 15/16" X 2 3/8"
T. ENTRADA:
1 1/2"
T. SALIDA:
1 3/4"
ENFRIADOR:
NO
CABECERAS:
3.385" X 25.945"
3.385" X 25.945"

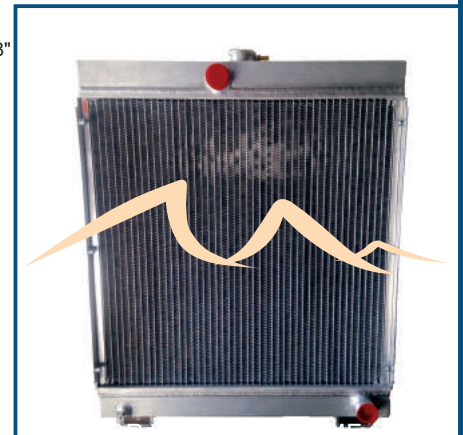

028

AA061-58N

INGERSOLL RAND

OIL COOLER

PANAL:
49 1/2" X 51 13/16" X 2 1/4"
T. ENTRADA:
ROSCA 1 1/2"-11 1/2"
T. SALIDA:
ROSCA 1 1/2"-11 1/2"
ENFRIADOR:
NO
REFERENCIAS:
39924048

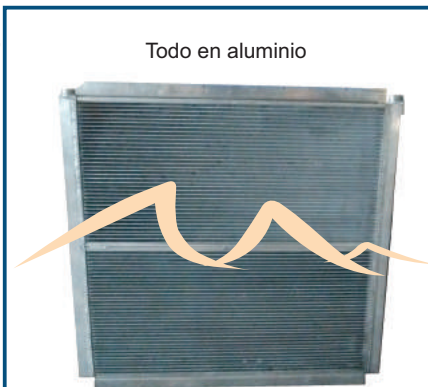

029

AA062-58N

OESSE

**COMPRESOR DE AIRE COMPRIMIDO
INTERCAMBIADOR DE CALOR**

PANAL:
19 1/4" X 21 15/16" X 2 1/4"
T. ENTRADA:
ROSCA 1 1/4" 12 HILOS NPT
T. SALIDA:
BRIDA CON ESTRADA DE 1"
ENFRIADOR:
NO
REFERENCIAS:
MUSTRA HC40121.01

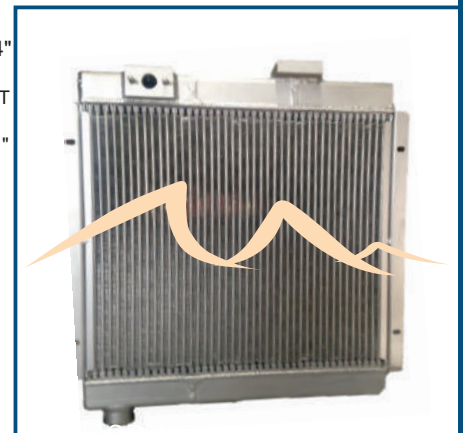

030

BBCAC-001

INTERNATIONAL 4900 JOROBADO 4300-4900

CORE SIZE:
23" X 29 1/8" X 1 3/4"
INLET:
3 1/2"
OUTLET:
3 1/2"
RADIADOR:
3975 90-02

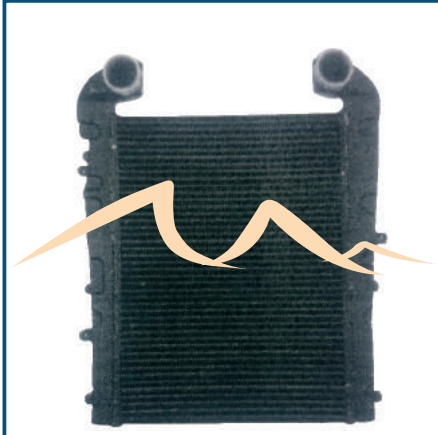

001

DICAC-001

POSTENFRIADOR DINA

PANAL:
30 5/16" X 24 11/16" X 1 3/4"
T. ENTRADA:
4"
T. SALIDA:
4"
RADIADOR:
8181 07-10

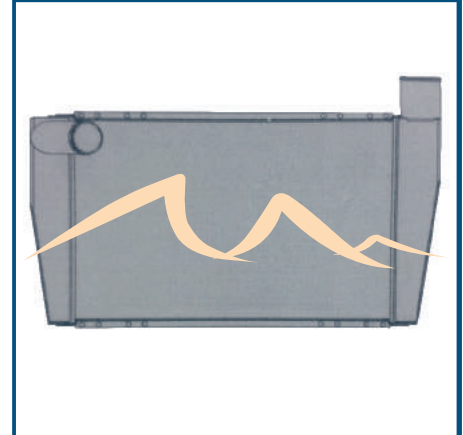

002

DOCAC-001

2008 DODGE RAM 5500 PICKUP/2003-2009 DODGE RAM PICKUP

CORE SIZE:
27 1/2" X 24 1/4" X 1 3/4"
INLET:
3 1/2"
OUTLET:
3 1/2"
RADIADOR:
A2711-44C

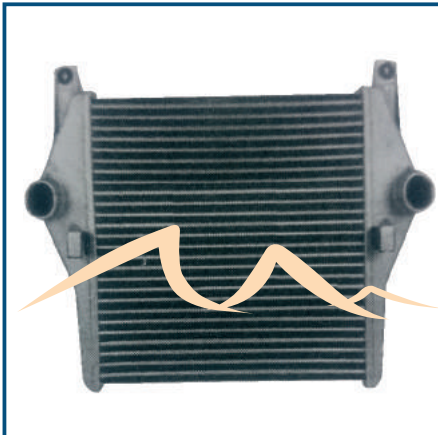

003

FRCAC-001

CLAS M2 07/C11299-00/C120 97-01/CLAS CST 112 97-03 COLUMBIA 03-11

PANAL:
36 13/16" X 26 3/4" X 1 3/4"
T. ENTRADA:
4"
T. SALIDA:
4"
RADIADOR:
8024

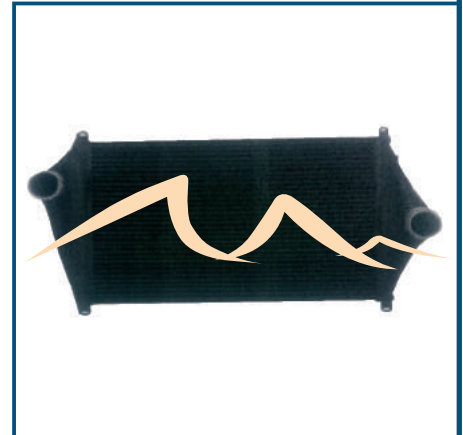

004

FRCAC-002

FLD11264ST 92/FLD12064ST 89-92/FLD12064TX 94

PANAL:
30 1/2" X 21 3/8" X 1 3/4"
T. ENTRADA:
4"
T. SALIDA:
4"
RADIADOR:
5603 93-99

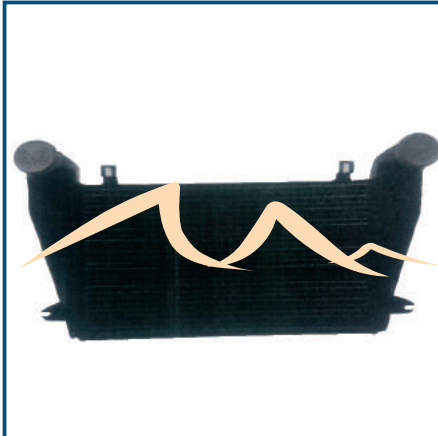

005

FRCAC-003

CLASSIC 120 06-07/COLUMBIA 112 06-07/FL60 BASE 94-03
STERLING FL SERIES 60-80

PANAL:
25 1/8" X 26 13/16" X 1 3/4"
T. ENTRADA:
3 1/2"
T. SALIDA:
3 1/2"
RADIADOR:
8024

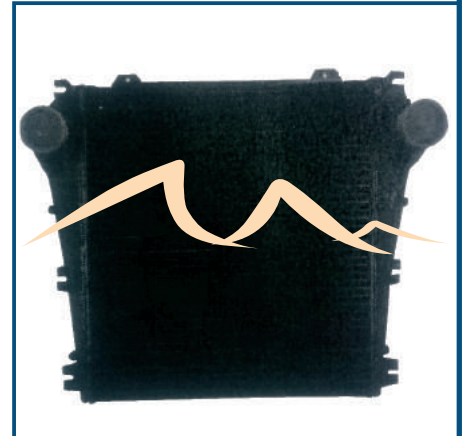

006

FRCAC-004

B2 BASE 06-08/CENTURY CLAS C112 98-00/COLUMBIA 04-05 FLD120

PANAL:
30 1/2" X 21 3/8" X 1 3/4"
T. ENTRADA:
4"
T. SALIDA:
4"
RADIADOR:
5603 93-99

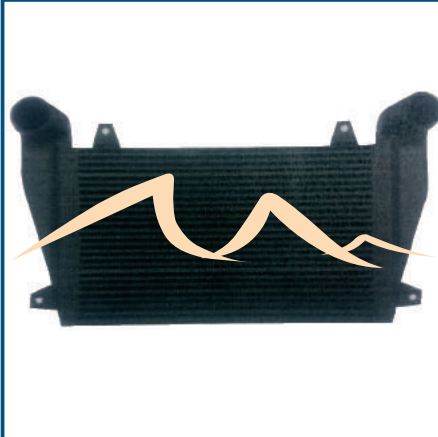

007

FRCAC-005

FLD 112 SERIES 95-02

PANAL:
36 13/16" X 22 3/16" X 1 3/4"
T. ENTRADA:
4"
T. SALIDA:
4"
RADIADOR:
8022

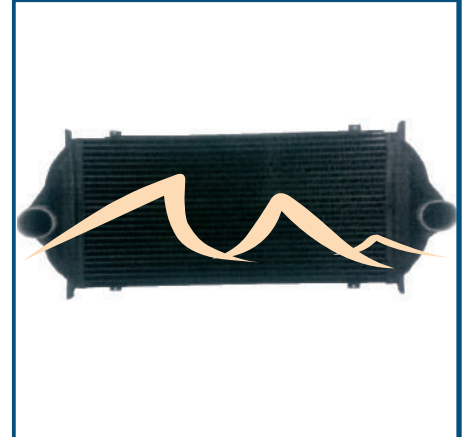

008

FRCAC-008

COLUMBIA-C112-C120/CENTURY CLASS/FLD120 ARGOSY 2000-2006
STERLING AT9500/7500/8500

PANAL:
36 13/16" X 26 3/4" X 1 3/4"
T. ENTRADA:
4"
T. SALIDA:
4"
RADIADOR:
8059

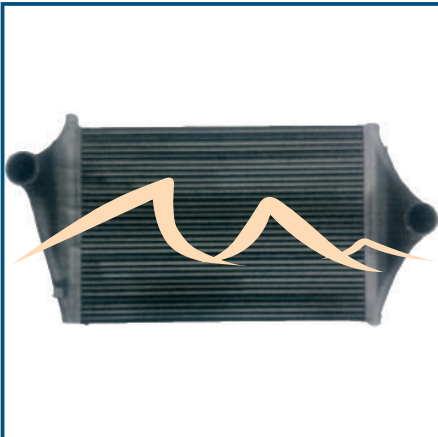

009

FRCAC-009

FLD 112, 120 "98-03" M2 106

CORE SIZE:
36 3/4" X 22 1/2" X 1 3/4"
INLET:
4"
OUTLET:
4"
RADIADOR:
8022 03-07

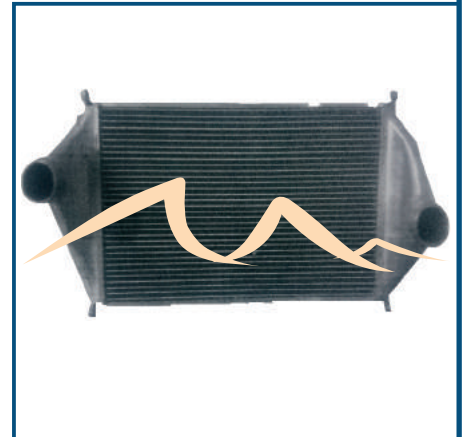

010

FRCAC-010

B2 BASE 06-08/BUSINESS CLAS M2 07-08/M2 106 BASE 04-07

PANAL:
27 1/2" X 14" X 2 1/4"
T. ENTRADA:
3 1/2"
T. SALIDA:
3 1/2"

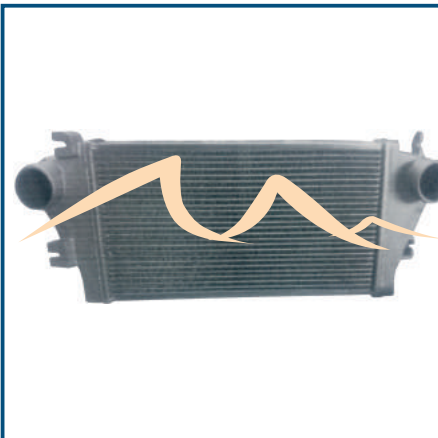

011

FRCAC-011

CASCADIA 08-13/FLD 08-09/STERLING AT 9500 08-09 800068

PANAL:
34 3/4" X 25" X 2 1/4"
T. ENTRADA:
4"
T. SALIDA:
4"

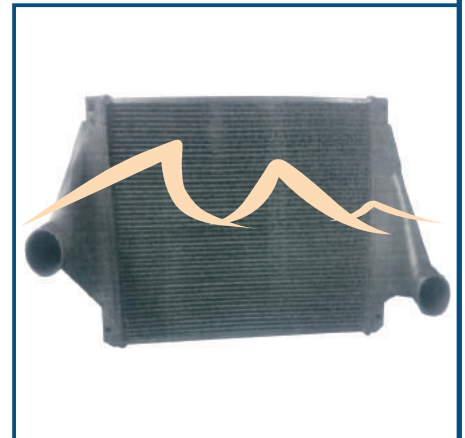

012

GMCAC-001

CHEVROLET CHARGE AIR COOLER KODIAK

CORE SIZE:
30 7/8" X 25 15/16" X 1 3/4"
INLET:
6 1/2"
OUTLET:
6 1/2"
RADIADOR:
6036 90-97

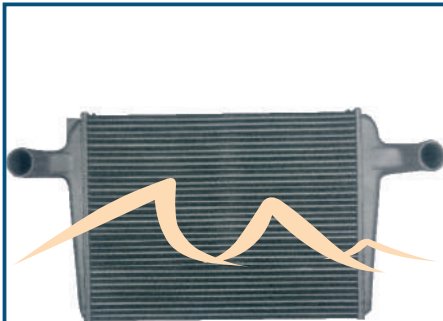

013

GMCAC-002

CHEVROLET CHARGE AIR COOLER KODIAK

CORE SIZE:
30 7/8" X 23 13/16" X 1 3/4"
INLET:
8 1/2"
OUTLET:
8 1/2"
RADIADOR:
6235 90-97

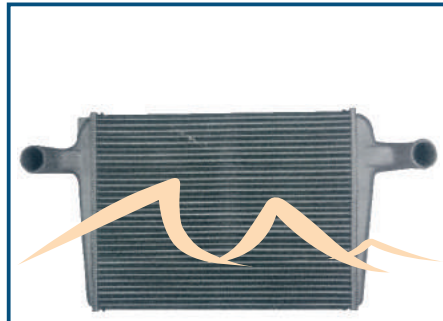

014

HYCAC-001

SUPER AERO CITY 14-15

PANAL:
34 3/4" X 21 1/2" X 2 1/4"
T. ENTRADA:
3 1/2"
T. SALIDA:
3 1/2"

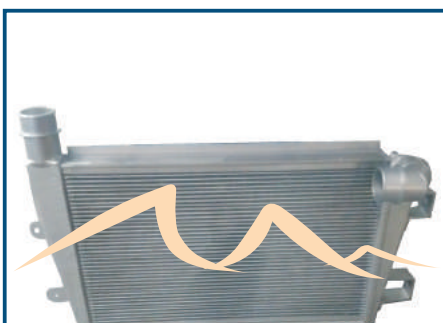

015

INCAC-001

INTERNATIONAL 2555 BASE 94-02/2574 BASE 95-03/2654 BASE 99-00
EAGLE 9100 9100i 98-03 9200 9200i 97-03 9400 9400i 97-06 9900 99-07

PANAL:
41" X 24 13/16" X 1 3/4"
T. ENTRADA:
4"
T. SALIDA:
4"
RADIADOR:
5967 94-03

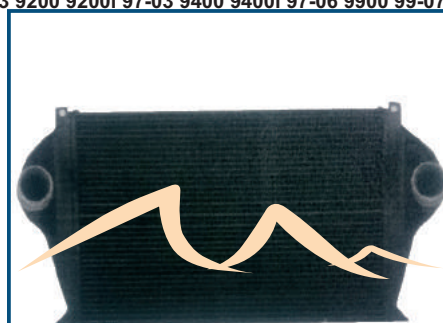

016

INCAC-002

INTERNATIONAL VENTANA BUS 94-06 4900 94-99

CORE SIZE:
22 13/16" X 12 1/16" X 2 1/4"
INLET:
4"
OUTLET:
4"
RADIADOR:
3973 / 3974 94-99

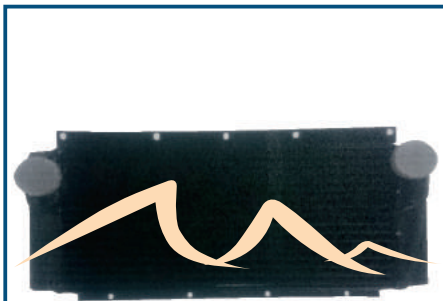

017

INCAC-005

INTERNATIONAL AUTOBUS 94-04

CORE SIZE:
23 X 12 5/8" X 2 1/4"
INLET:
3"
OUTLET:
3"
RADIADOR:
8175 / 8193

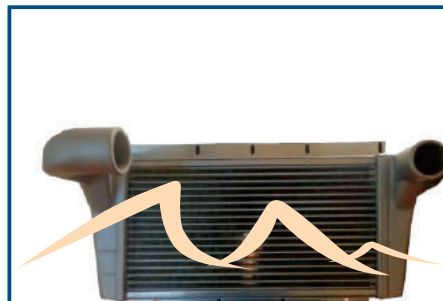

018

INCAC-006

INTERNATIONAL 8000 07-10/PROSTAR PRO 08-11 GAGLE 9100i 9200i 9400i 9900i 07-09

PANAL:
39 1/4" X 11 9/16" X 3 3/4"
T. ENTRADA:
4"
T. SALIDA:
4"
RADIADOR:
8143



019

INCAC-007

SERIES PROSTAR 08-12 EAGLE 9100i 9200i 9400i 9900i 07-09

PANAL:
39 3/4" X 13 1/16" X 3 3/4"
T. ENTRADA:
4"
T. SALIDA:
4"
RADIADOR:
8343



020

INCAC-010

BASE 3700, 7600, 8600, 9200i, 9400i 03, 9900, 9900i, 9900ix 99-07

PANAL:
30 1/4" X 15 5/16" X 3 3/4"
T. ENTRADA:
4"
T. SALIDA:
4"

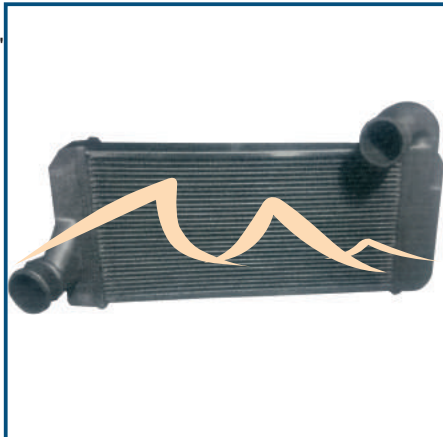

021

INCAC-011

INTERNATIONAL 4700-7300 SERIES 02-07

PANAL:
27 7/8" X 9 3/4" X 3 3/4"
T. ENTRADA:
3"
T. SALIDA:
3 1/2"

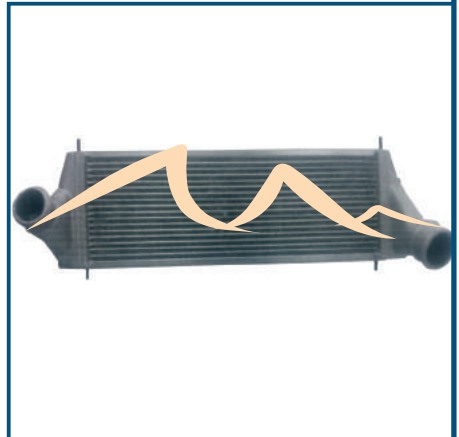

022

INCAC-015

BASE 7000, 7300, 7400, 7500, 7600 WORKSTAR 08-10

PANAL:
46 3/4" X 24 9/16" X 1 3/4"
T. ENTRADA:
4"
T. SALIDA:
4"
RADIADOR:
8201

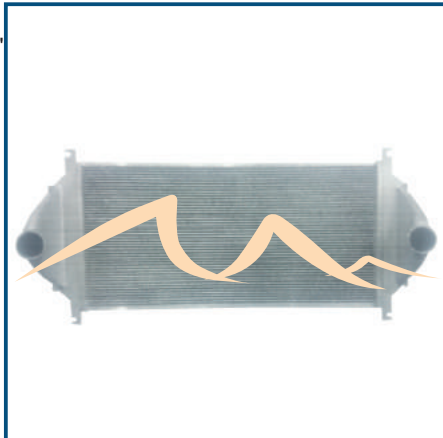

023

KECAC-001

T800 BASE 2006-2007

PANAL:
28 7/16" X 27 7/16" X 1 3/4"
T. ENTRADA:
4"
T. SALIDA:
4"
RADIADOR:
5594 / 6213 44-10



024

KECAC-002

K100 90"/T2000 99-06/T300 96-05/T600A 06-07

PANAL:
28 7/16" X 27 7/16" X 1 3/4"
T. ENTRADA:
4"
T. SALIDA:
4"
RADIADOR:
5599 / 6213 94-10

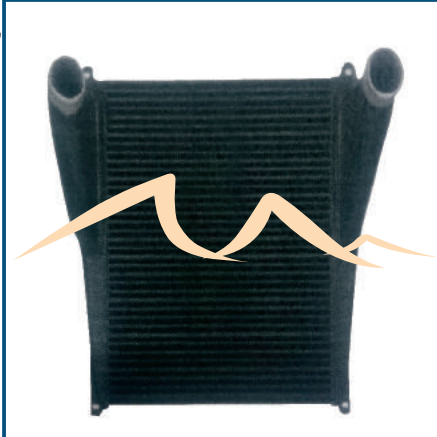

025

KECAC-003

KENWORTH T-2000 97-07/T800 02-03

PANAL:
39 7/16" X 25 1/16" X 1 3/4"
T. ENTRADA:
4"
T. SALIDA:
4"
RADIADOR:
8061



026

KECAC-004

KENWORTH T-300 95-05/T400 95-98 T800 04-07

PANAL:
37" X 17 1/16" X 1 3/4"
T. ENTRADA:
4"
T. SALIDA:
4"
RADIADOR:
5736

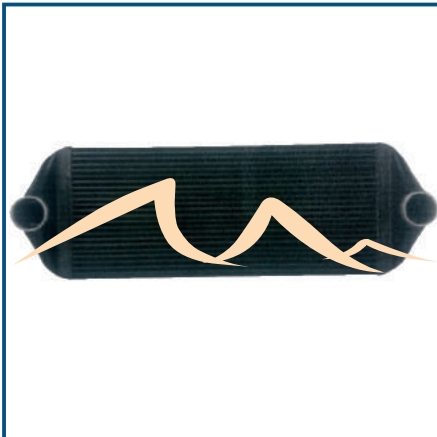

027

KECAC-005

T800H/T800W/W900B 96-03/C500B 07-12

PANAL:
34 7/8" X 22 7/8" X 2 1/4"
T. ENTRADA:
4"
T. SALIDA:
4"
RADIADOR:
8048

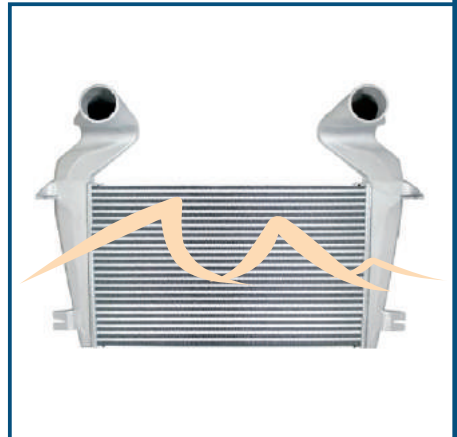

028

KECAC-006

KENWORTH T660 08-13/W900 81-11

PANAL:
29 1/4" X 31 1/32" X 1 3/4"
T. ENTRADA:
4"
T. SALIDA:
4"
RADIADOR:
8174

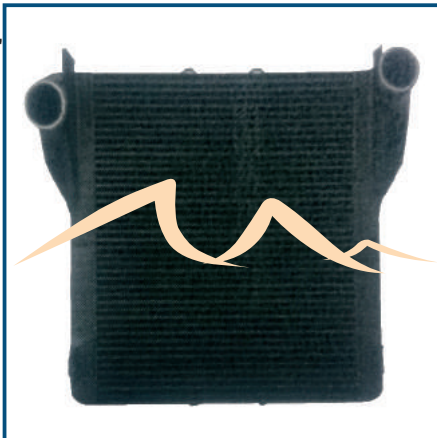

029

KECAC-007

KENWORTH T300-T370/PETERBILT 330, 335, 340

PANAL:
37" X 16 1/16" X 1 3/4"
T. ENTRADA:
4"
T. SALIDA:
4"
RADIADOR:
8289 / 8287 08-11

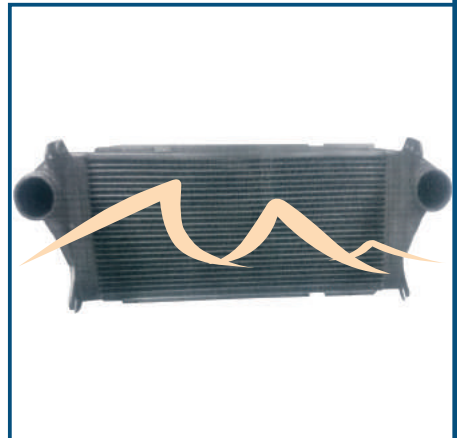

030

KECAC-010

KENWORTH T300 03-07/T800 07/W900 83
PETERBILT 330 03-07/335 05-07/340 07

PANAL:
32 3/8" X 9 3/16" X 3 3/4"
T. ENTRADA:
3 9/16"
T. SALIDA:
3 9/16"
RADIADOR:
8062



031

MECAC-001

MOTOR: 924

PANAL:
23 1/2" X 23 11/16" X 2 1/4"
T. ENTRADA:
3 1/8"
T. SALIDA:
3 1/8"
RADIADOR:
8207 09-10



032

MECAC-002

MOTOR: 904/906

PANAL:
30" X 20 7/8" X 2 3/4"
T. ENTRADA:
3 15/16"
T. SALIDA:
3 15/16"
RADIADOR:
6238 03-07

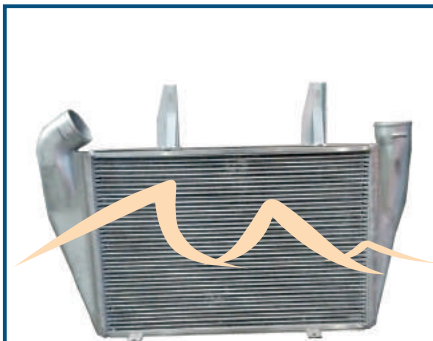

033

NBCAC-001

FLEXLINES/NOVA BUS METRO TRANSIT BUSES

CORE SIZE:
25" X 20 3/8" X 1 3/4"
INLET:
4"
OUTLET:
4"

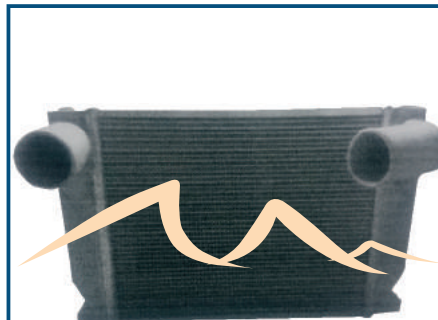

034

PBCAC-001

PETERBILT 357-377-379-385

CORE SIZE:
33 5/8" X 29 15/16" X 1 3/4"
INLET:
4 1/8"
OUTLET:
4 1/8"
RADIADOR:
8036 89-07

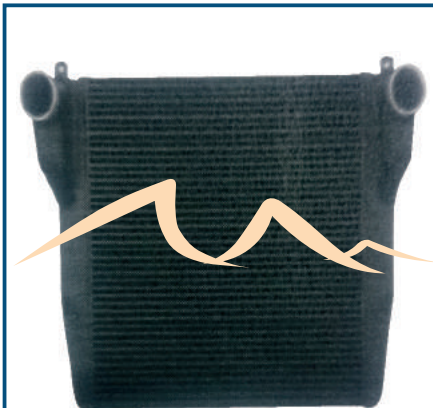

035

VOCAC-001

VN SERIES 86-07

PANAL:
34 1/4" X 36 1/16" X 1 3/4"
T. ENTRADA:
4"
T. SALIDA:
4"
RADIADOR:
6003 00-08

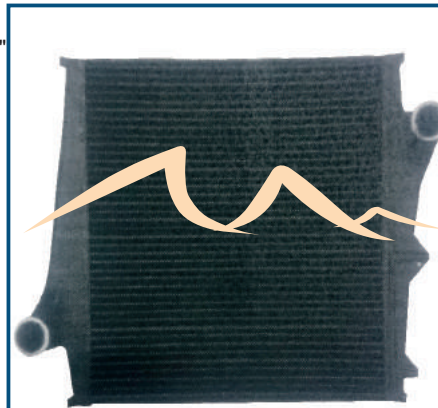

036

VOCAC-002

VN SERIES 99-07

PANAL:
34 1/4" X 36 1/16" X 1 3/4"
T. ENTRADA:
4"
T. SALIDA:
4"
RADIADOR:
6003 00-09

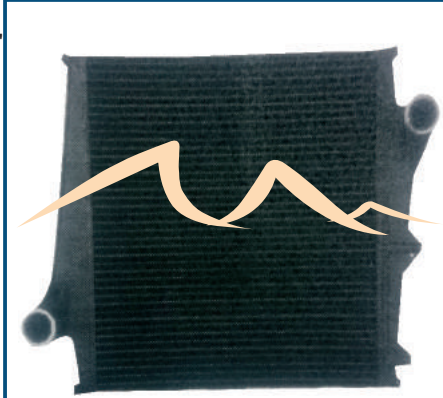

**PRUEBA NUESTRA
VERSION IMPRESA**

EN LÍNEA
www.phar.com.mx

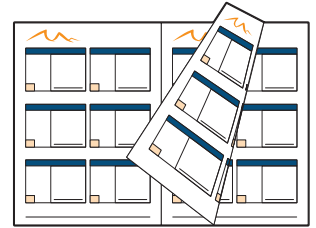

037

NOTAS

A large area with horizontal lines for taking notes, set against a light orange background.

NOTAS

Large lined area for notes.

AC3000

CHRYSLER

INTREPID/CONCORDE/LHS/300M 98-04

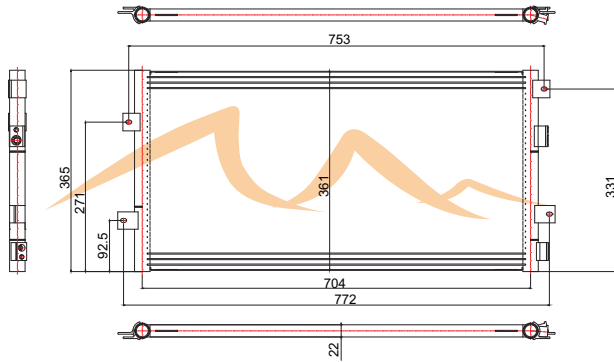

Radiador: 2184 / 2183

OEM: 4758305AB

AC3014

CHEVROLET/GMC

COLORADO/CANYON 04-12

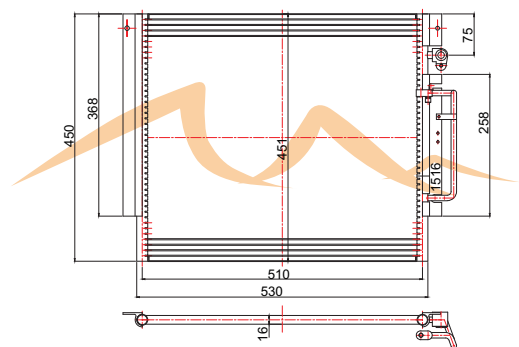

Radiador: 2707

OEM: 890191470

AC3026

CHEVROLET/GMC/CADILLAC

SUBURBAN/TAHOE/YUKON/ESCALADE 00-05

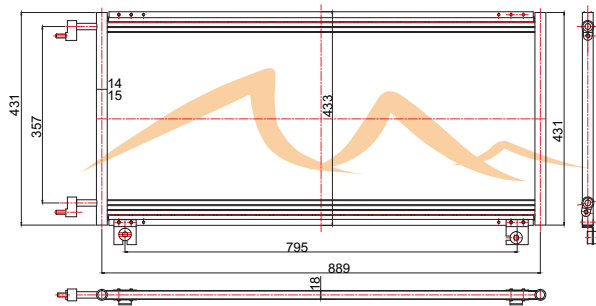

Radiador: 2334 / 2370 / 2423

OEM: 25807797

AC3050

CHEVROLET/OLDSMOBILE/PONTIAC

VENTURE/SILHOUETTE/AZTEK/MONTANA 01-05
BUICK RENDEZVOUS/TERRAZA 02-07
SATURN RELAY 05-06
CHEVROLET UPLANDER 01-05

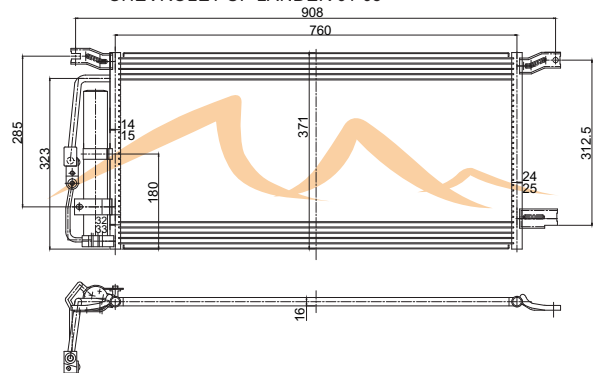

Radiador: 2562 / 2728

OEM: 10339103

AC3057

NISSAN

ALTIMA 02-06/MAXIMA 04-08

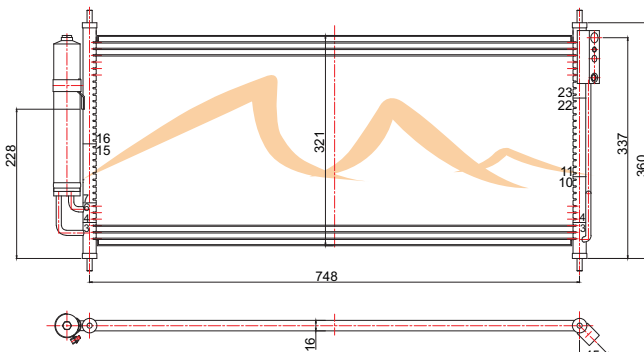

Radiador: 2414 / 2415 / 13005

OEM: 921007Y000

AC3058

JEEP

LIBERTY 02-05

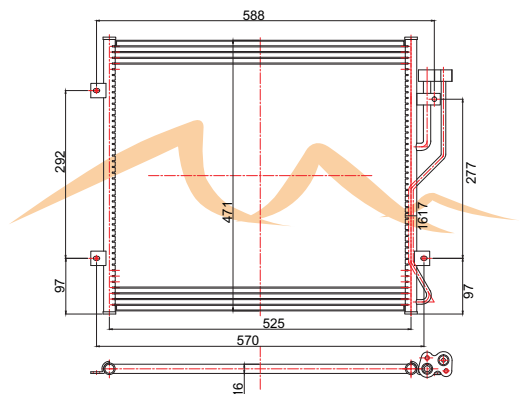

Radiador: 2481 / 2482

OEM: 5183560AA

AC3092

FORD

F-150/F-250/LOBO 04-08

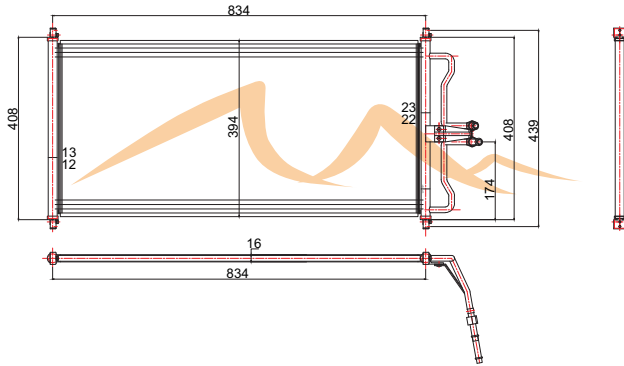

Radiador:2719 / 2596 / 2886

OEM: 7L3Z19712A

AC3112

HONDA

CRV 02-06/ELEMENT 03-11

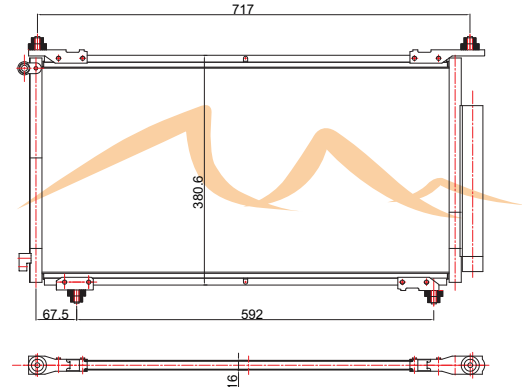

Radiador:2443

OEM: 80110SCVA01

AC3182

HONDA/ACURA

MDX 01-06/PILOT 03-08

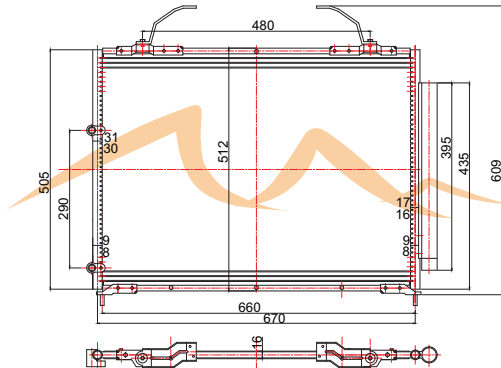

Radiador:2417 / 2740 / 2956

OEM: 80110SNAA01

AC3237

CHRYSLER/DODGE

300/CHARGER/CHALLENGER 05-12 V6/V8/SRT

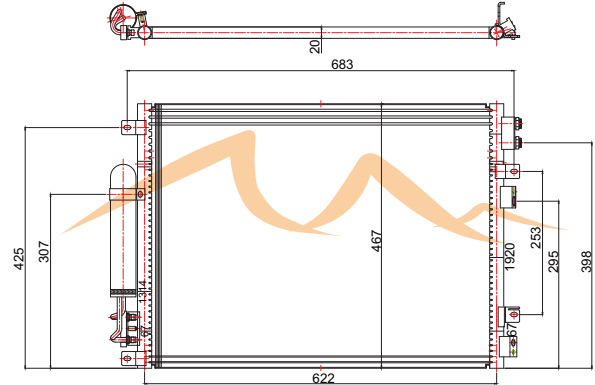

Radiador:2766 / 2767 / 3512

OEM: 5137693AB

AC3239

NISSAN

TITA 03-05/ARMADA 04-15/PATHFINDER 08-12/INF Qx566 04-10

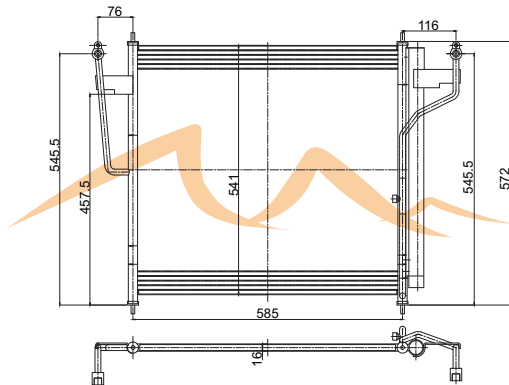

Radiador:2691 / 2807

OEM: 92100-ZC10A

AC3246

HONDA

ODYSSEY 05-10

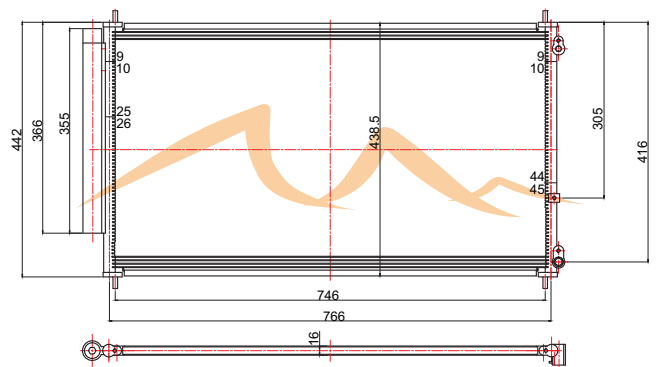

Radiador:2806

OEM: 80110SHJA01

AC3247

JEEP

GRAND CHEROKEE V6/V8/SRT 05-10/COMMANDER 06-10

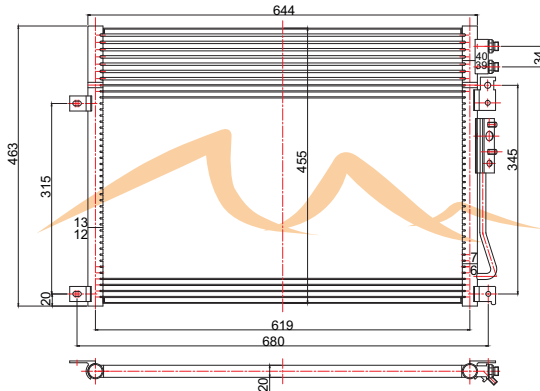

Radiador: 2839 / 2840

OEM: 55116928AA

AC3255

VOLKSWAGEN/AUDI

A3 03-13/TT 07-13/BORA 06-10/EOS 07-14/GOLF 06-14/JETTA 06-10

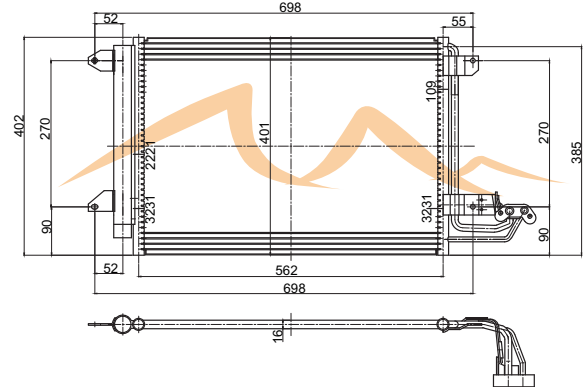

Radiador: 2822 / 2995 / 3212 / 13444 / 13030

OEM: 1K0820411Q

AC3279 CHEVROLET/PONTIAC

CONDENSER MALIBU/MAXX 04-12/PONTIAC G6 05-10

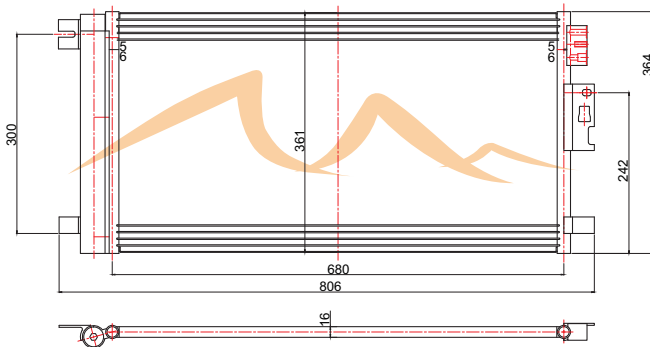

Radiador: 2765 / 2727 / 2864

OEM: 20820058

AC3284

TOYOTA

SIENNA 04-10

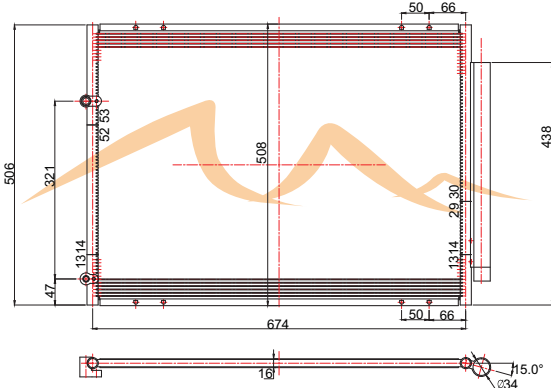

Radiador: 13076 / 2681 / 2925

OEM: 8846108010

AC3294 VOLKSWAGEN/AUDI/PORSHE

Q7 07-15/CAYENNE 03-10/TOUAREG 04-10

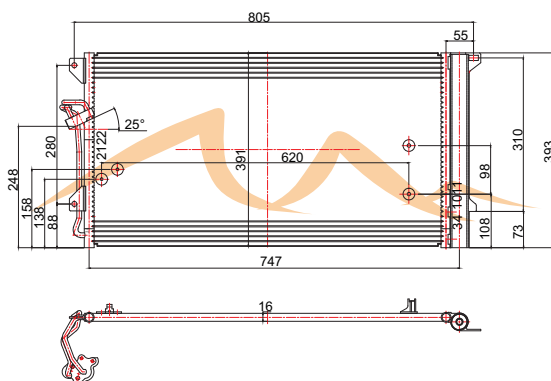

Radiador: 2756

OEM: 4L0260401A

AC3331

NISSAN

FRONTIER/XTERRA 05-15/PATHFINDER 05-12

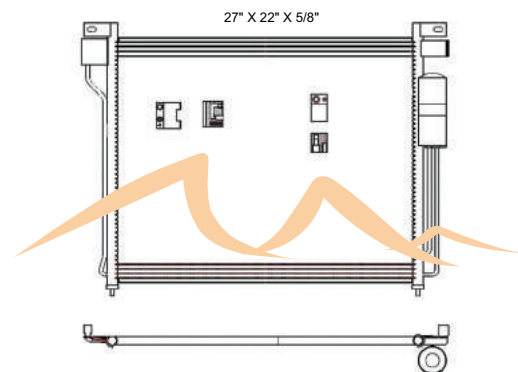

Radiador: 2807 / 2808

OEM: 92100EA500

AC3362

FORD

MUSTANG 05-09

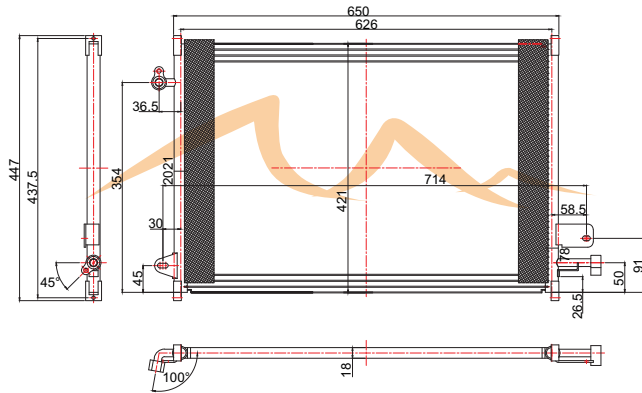

Radiador:2789

OEM: 6R3Z19712AA

AC3393

TOYOTA

TACOMA 05-12

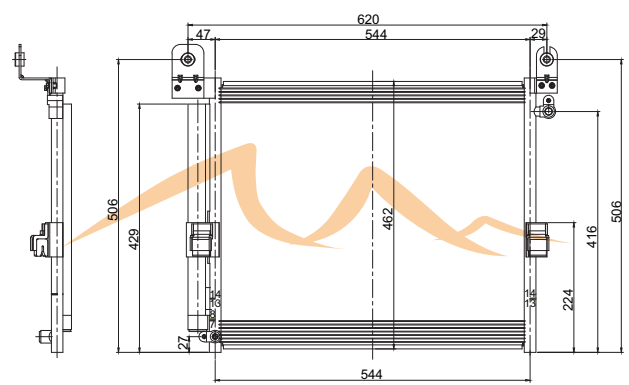

Radiador:2802

OEM: 8846004210

AC3493

VOLKSWAGEN

PASSAT 4 Y 6 CIL. 06-10/CC 09-16

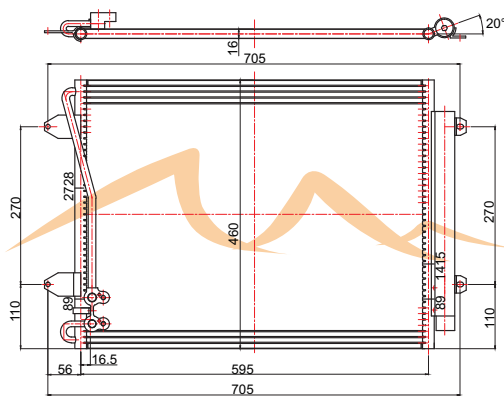

Radiador:2822 / 2964 / 13212

OEM: 3C0820411B

AC3525

HONDA/ACURA

CIVIC/CSX 06-11

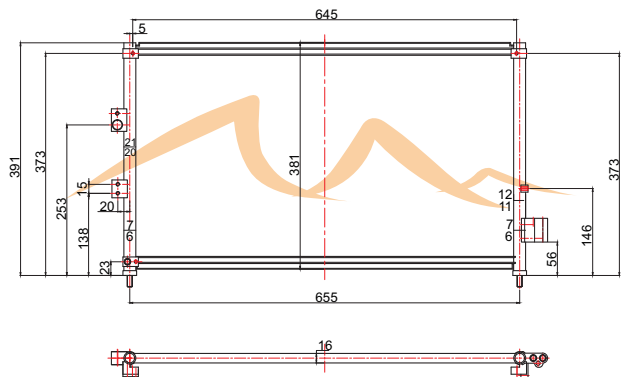

Radiador:2922 / 2923 / 2927

OEM: 80110SNA01

AC3569

HONDA

CIVIC COUPE ONLY/ALL ENGINES 06-11

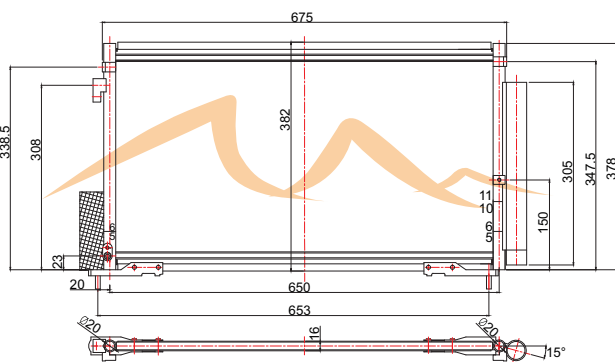

Radiador:2922 / 2927

OEM: 80102SVAA12

AC3575

TOYOTA

RAV 4 06-12

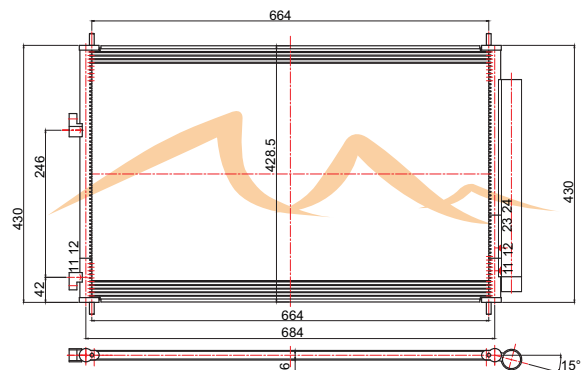

Radiador:2891 / 2892 / 2893

OEM: 8846042100

AC3580 TOYOTA

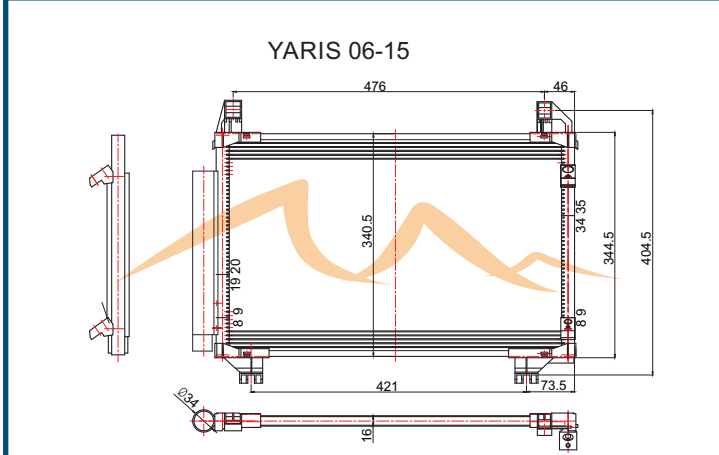

Radiador: 2890 / 2889 OEM: 8846052130

AC3586 CHRYSLER/DODGE

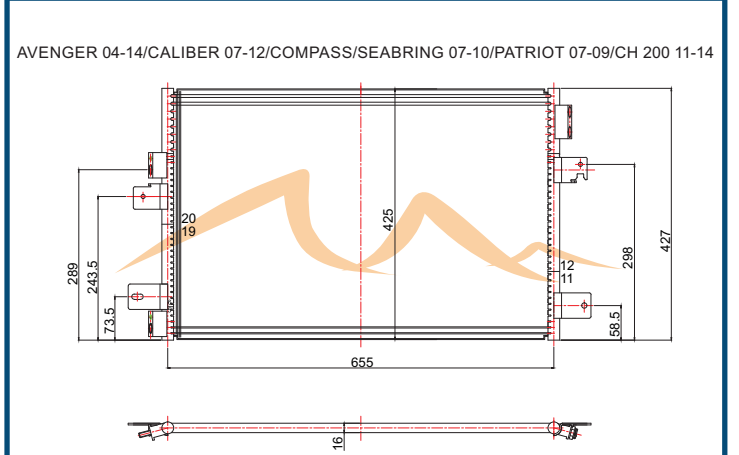

Radiador: 2951 OEM: 68004053AA

AC3594 NISSAN

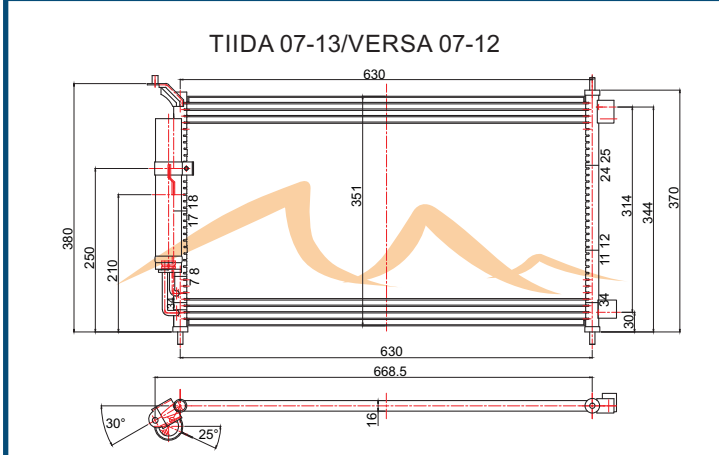

Radiador: 2981 / 3002 OEM: 92100ZW40A

AC3599 HONDA

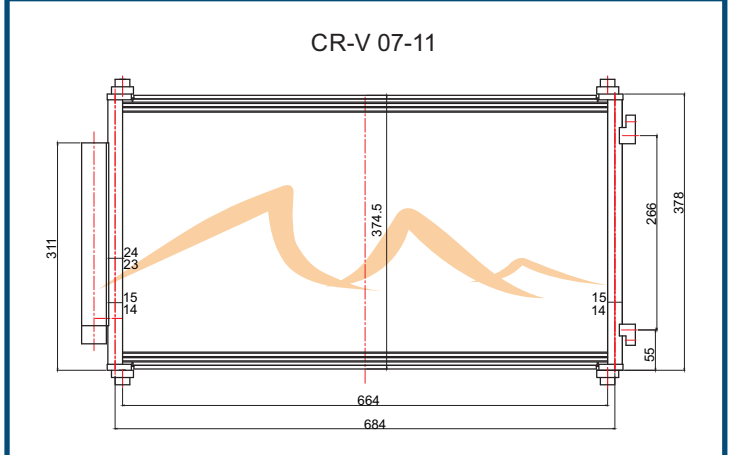

Radiador: 2954 / 13031 / 13155 / 13161 OEM: 80110SWAA01

AC3618 FORD/LINCOLN

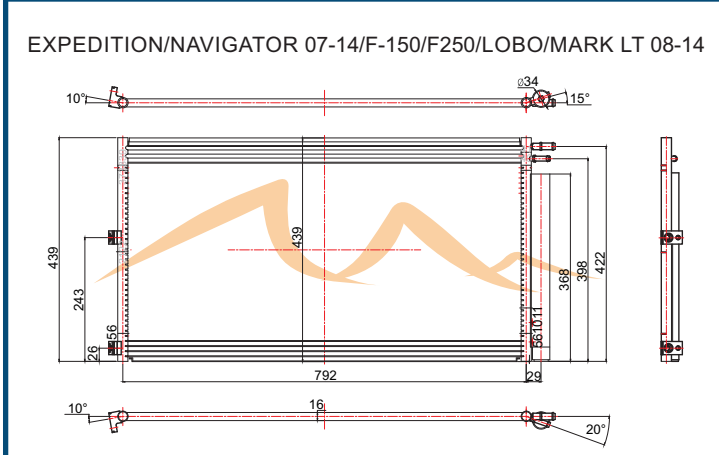

Radiador: 13045 / 13099 / 13226 / 13229 OEM: 7L1Z19712A

AC3628 NISSAN

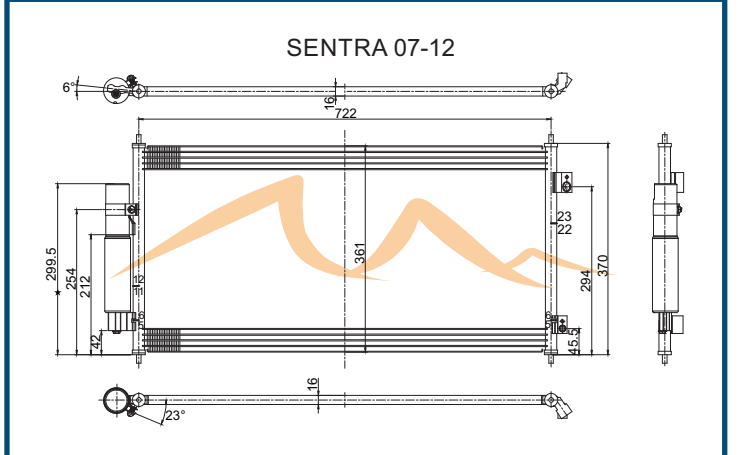

Radiador: 2998 OEM: 92100ZE80A

AC3639

NISSAN

ALTIMA 07-15/MAXIMA 09-14

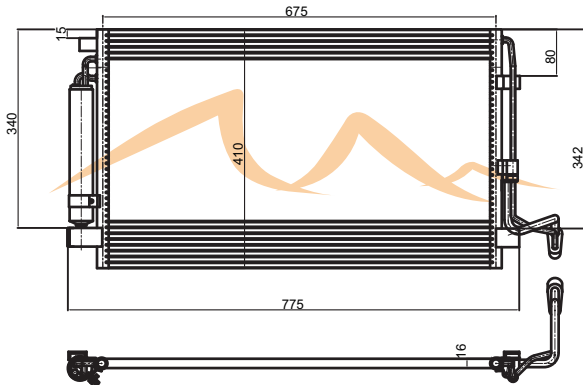

Radiador:2988

OEM: 92100ZN50B

AC3649

CHEVROLET/BUICK

ENCLAVE 08-16/TRaverse 09-16/ACADIA 07-16

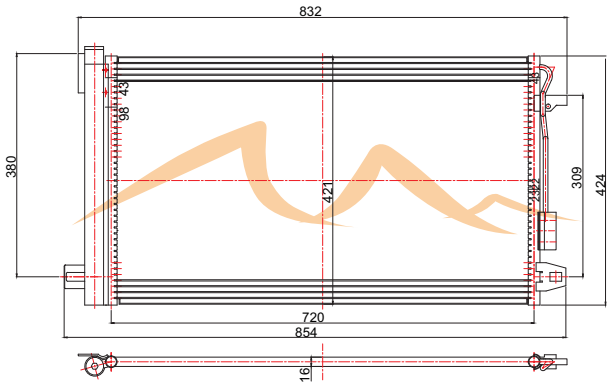

Radiador:13007

OEM: 25975431

AC3669

HONDA

ACCORD 08-12/CROSSTOUR 10-15

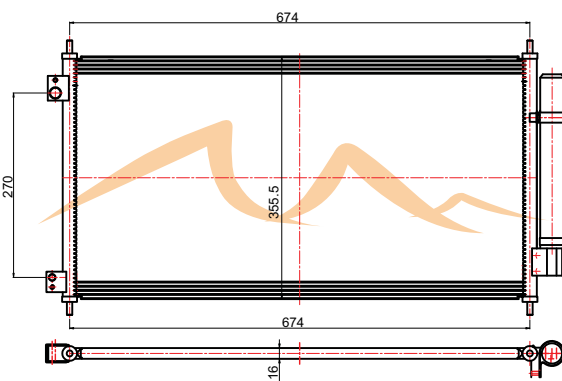

Radiador:LHRP555 / LHRP 349-1R

OEM: 80110TA0A01

AC3672

FORD

FOCUS A/T 08-11

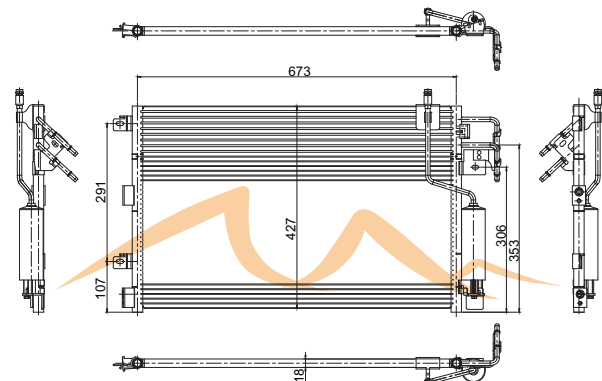

Radiador:13087

OEM: AS4Z19712A

AC3678

FORD/LINCOLN

FLEX 09-12/TAURUS 08-16/MKS 09-12/MKT 10-12/SABLE 08-09

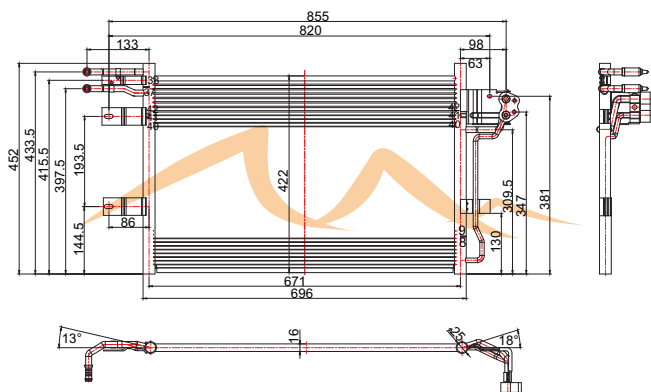

Radiador:2937 / 13185

OEM: 8G1Z19712A

AC3680

NISSAN

ROGUE 08-12

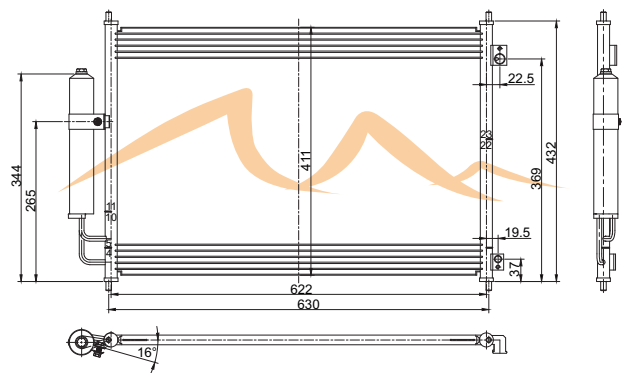

Radiador:13047

OEM: 92100JG000

AC3682 CHRYSLER/DODGE

CARAVAN/TOWN AND COUNTRY 08-16

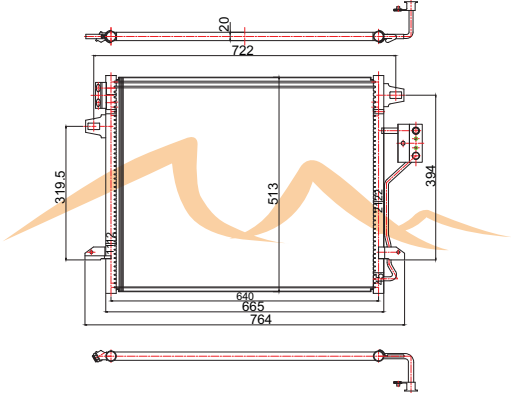

Radiador:13063

OEM: 4677782AA

AC3760 MERCEDES BENZ

C CLASS 08-14/SERIE "E" 10-15/GLK 10-15/SLK 12-16/SLS 11-14

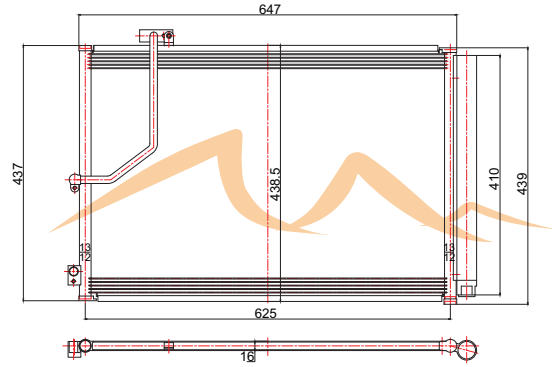

Radiador:2751 / 13162

OEM: 2045000254

AC3771 HONDA

PILOT 09-15

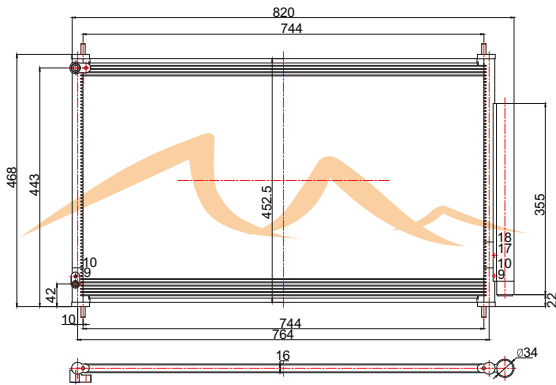

Radiador:13065

OEM: 80110SZAA01

AC3774 NISSAN

MURANO 08-14/QUEST 11-16

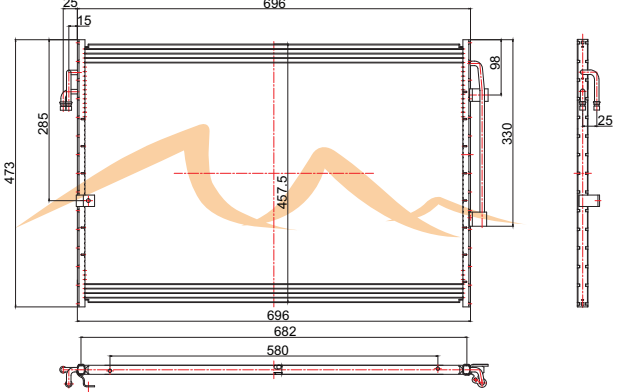

Radiador:13039

OEM: 921101AA0A

AC3782 FORD/MERCURY/MAZDA

ESCAPE 09-12/TRIBUTE 09-11/MARINER 09-11

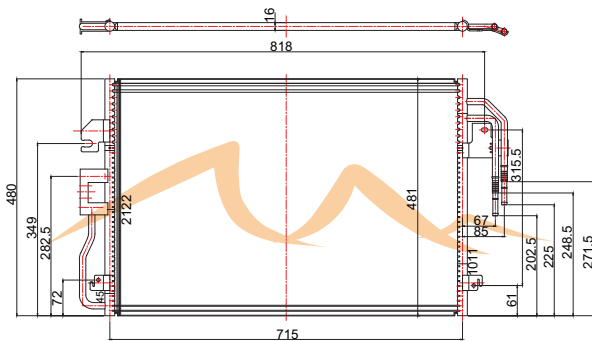

Radiador:13060 / 13041

OEM: 9L8Z19712A

AC3789 CHEVROLET/GMC

EQUINOX 10-15/TERRAIN 10-16

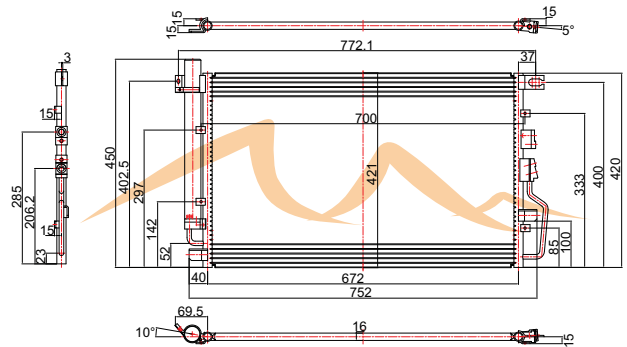

Radiador:13103

OEM: 20839794

AC3794 CHEVROLET/BUICK/CADILLAC

LACROSSE 10-16/REGAL/VERANO 12-16/XTS 13-16/CRUZE 11-15/IMPALA 14-16/MALIBU

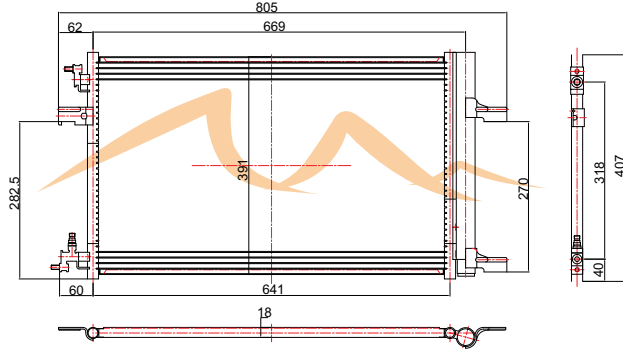

Radiador: 13146 / 13197 / 13471 / 13246

OEM: 22869501

AC3869

TOYOTA

SIENNA/LEXUS Rx350 11-15

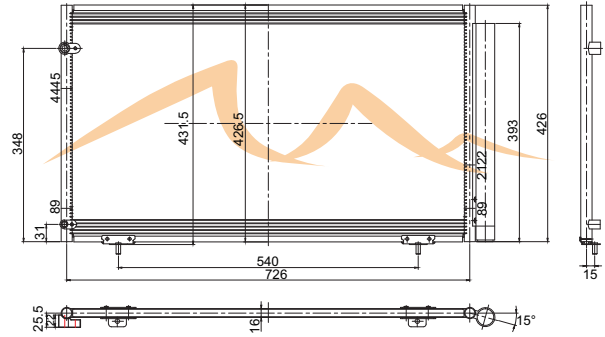

Radiador: 13116 / 13117

OEM: 8846008020

AC3881

FORD

FIESTA 08-13

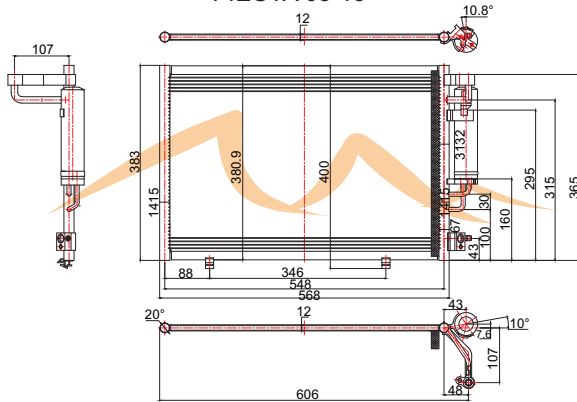

Radiador: 13201

OEM: BE8Z19712A

AC3889

VOLKSWAGEN

BEETLE 12-15/GOLF 11-13/JETTA 11-15

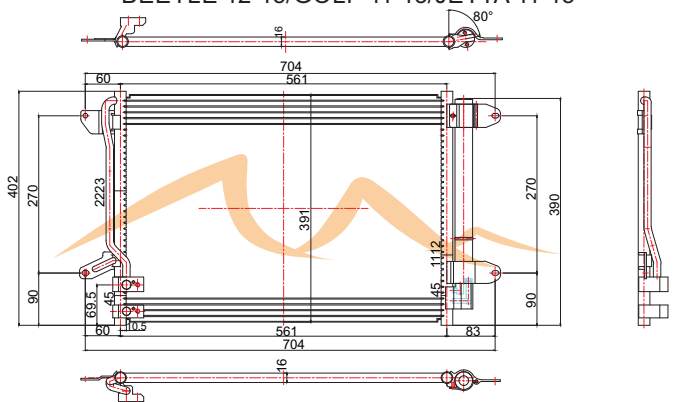

Radiador: 13215 / 2822 / 3444

OEM: 5C0820411

AC3893

DODGE/JEEP

DURANGO 11-15/GRAND CHEROKEE 10-15

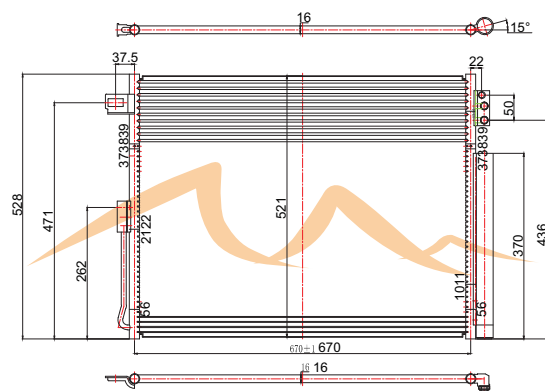

Radiador: 13200

OEM: 55038003AE

AC3897

CHRYSLER/DODGE

300/CHALLENGER/CHARGER 09-16

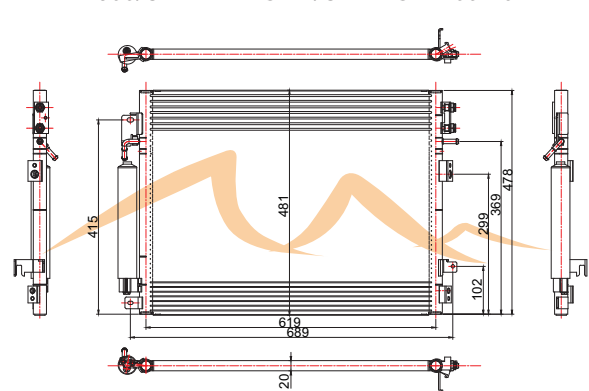

Radiador: 13157 / 13158 / 13512

OEM: 68050127AB

AC3932

TOYOTA

PICKUP 89-93

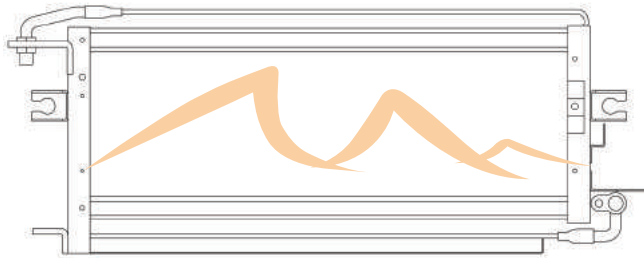

10 3/4" X 21" X 1"

Radiador:0945 / 0050 / 1190 / 0147

OEM: 8846035130

AC3968

NISSAN

JUKE 11-16

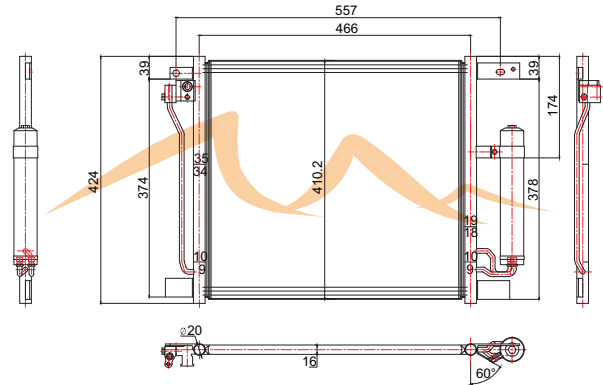

Radiador:13264

OEM: 921103DD0A

AC3975

FORD/LINCOLN

EXPEDITION 15-16/F150 13-14/NAVIGATOR 15-16

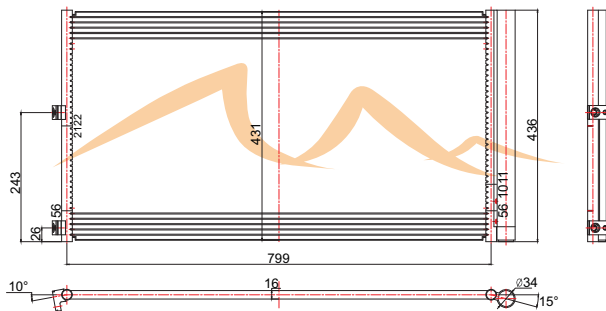

Radiador:13228 / 13229 / 13226

OEM: BL3Z19712A

AC3976

HONDA

CIVIC 1.8L - 2.4L 12-15

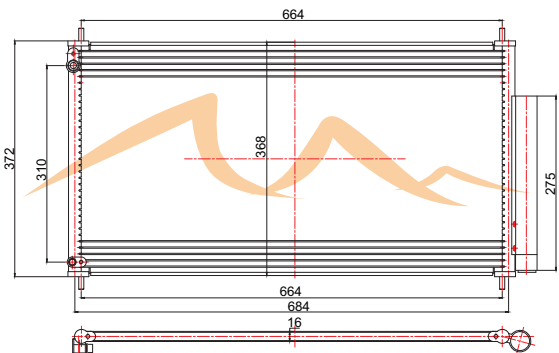

Radiador:13257 / 13221

OEM: 80110TS4T01

AC3995

TOYOTA/LEXUS

ES-350 13-16/CAMRY 12-16/AVALON HYBRID 13-15

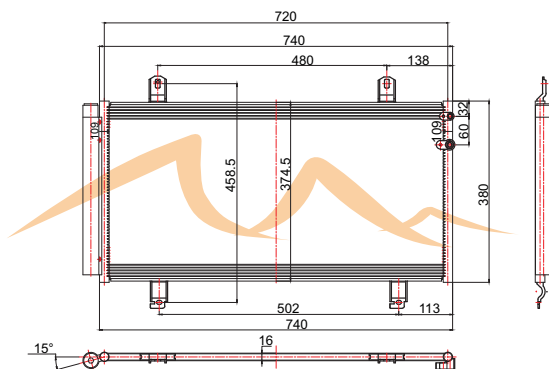

Radiador:13269 / 13270 / 13338

OEM: 8846033170

AC3997

HONDA

CRV 12-16

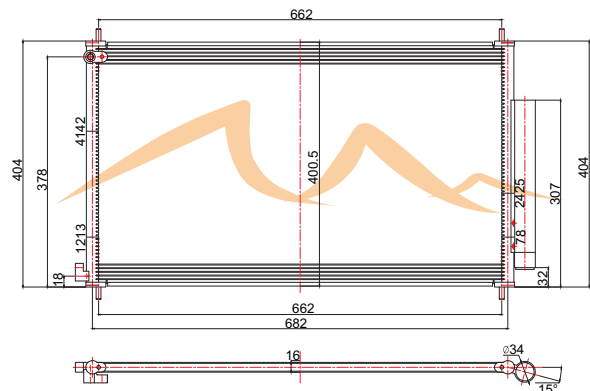

Radiador:13314

OEM: 80110T0AA01

CONDENSADORES

AC4953 CHEVROLET/CADILLAC

ESCALADE 02-15/AVALANCHE 02-13/CHEYENNE 07-13/SILVERADO 95-13
HUMMER H2

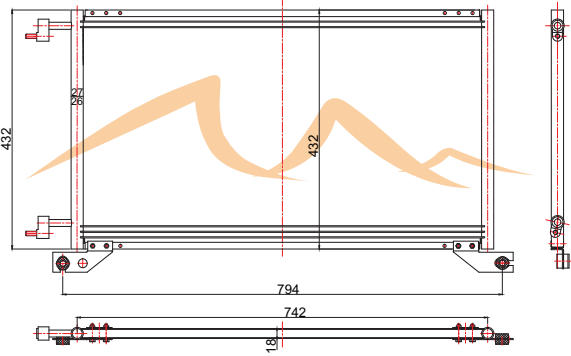

AC4957 CHRYSLER/DODGE

CARAVAN/VOYAGER/TOWN AND COUNTRY 01-04

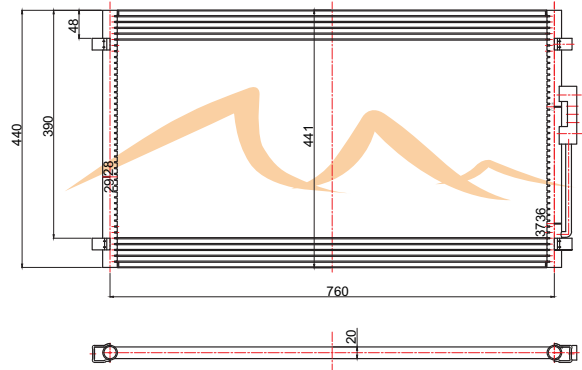

Radiador: 2311 / 2312

OEM: 48092274D

AC4977 HONDA

CIVIC/ACURA EL 01-05

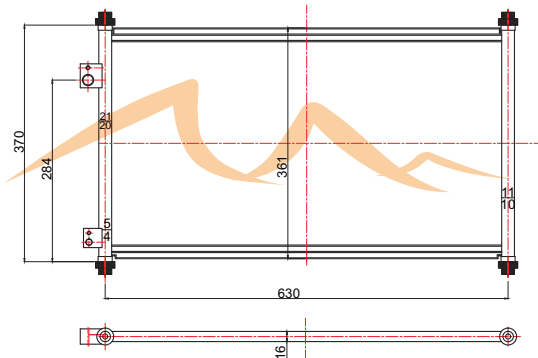

Radiador: 2354

OEM: 80100S87A00

PRUEBA NUESTRA VERSION IMPRESA

EN LÍNEA
www.phar.com.mx

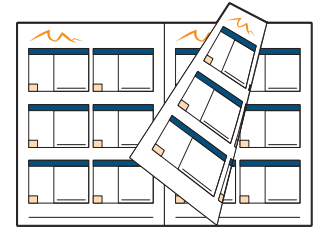

NOTAS

CODIGO	APLICACION	AÑOS	DIBUJO /PAGINA	CODIGO	APLICACION	AÑOS	DIBUJO /PAGINA
1318	CAMRY L4 2.2	92-96	023/140	2088	SIDEKICK/TRACKER M/T L4 1.6	96-97/96-98	016/135
1319	TERCEL/PASEO L4 1.5	91-95	024/140	2089	TRACKER X-90 L4 1.6	94-98	017/135
1323	626/MX6 SPORT COUPE L4 2.0/2.2	92-97	14/101	2090	T-100 L4 2.7 V6 3.0/3.4	93-98	039/142
1326	MX-6/626 (26 AT) V6 2.5	93-97	15/101	2148	ACCORD L4 2.3	98-02	030/83
1344	BERETTA/CORSICA L4 2.2/2.3 V6 3.1	92-94	029/127	2150	ALTIMA L4 2.4	99-02	060/116
1392	CARAVAN/VOYAGER V6 3.0	93-95	060/52	2151	FRONTIER/XTERRA L4 2.4 V6 3.3	98/00-04	061/116
1393	MIRAGE/LOLT L4 1.5/1.8	93-96	47/105	2191	S-SERIES L4 1.9	94-02	014/131
1409	COROLLA L4 1.6/1.8	93-97	025/140	2195	PASSAPORT/RODEO V6 3.2/3.5	98-03	031/83
1428	CAMRY L4 2.2	92-96	026/140	2198	PRIZM/COROLLA L4 1.8	98-02	040/142
1444	SIDEKICK/TRACKER/SWIFT L4 1.0/1.4/1.6	88-94	014/135	2203	ACCORD L4 2.3	98-02	032/83
1453	F-SERIES/BRONCO V8 5.0/5.8	85-97	100/73	2251	LUMINA/MONTECARLO V6 3.1/3.4/3.8	96-01	033/127
1474	DE VILLE V8 4.9	91-93	031/23	2265-24M	GOLF/JETTA L4 1.8/1.9/2.0 V6 2.8	99-05	025/150
1476	TRANS SPORT/LUMINA APV V6 3.8	92-95	98/120	2270	ODISSEY/OASIS L4 2.3 V6 3.5	99-03	033/83
1486	CAMARO/TRANS AM V8 5.7	93-02	108/37	2278	MONTERO SPORT V6 3.0/3.5	97-03	54/105
1489	G SERIES VANS V6 4.3 V8 5.0/5.7	92-93	109/38	2285	540i/740i M5/Z8 V8 4.4/5.0	97-03/95-01	031/17
1512	T-100 L4 2.7 V6 3.0/3.4	93-98	027/140	2290	E320 V6 3.2	98-02	33/103
1518	LUMINA/CUTLASS/KESAL V6 3.1/3.8	94-97	99/120	2291	RAM V8 5.9	98-02	064/53
1519	LUMINA/CUTLASS/GRAND PRIX V6 3.1/3.4/3.8	94-01	015/21	2292	RAV-4 L4 2.0	98-00	41/142
1522	PICK UP SUBURBAN C/K SERIES V8 5.0/5.7	96-99	112/38	2300	GALANT L4 2.4	99-02	55/106
1532	S-10/BLAZER/ JIMMY/SONOMA V6 4.3	93-94	113/38	2301	GALANT V6 3.0	99-02	56/106
1557	GOLF/GTI/JETTA/CABRIO L4 1.8/1.9/2.0	92-02	011/149	2303	PROTEGE 5 L4 1.6/1.8/2.0	99-03	18/101
1568	INTEGRA L4 1.8	94-01	004/14	2304	ECHO L4 1.5	00-05	042/142
1571	RODEO/PASSAPORT V6 3.2/3.5	93-01	027/82	2305	YARIS 1300/ECHO L4 1.5	00-05	043/142
1575	CELICA L4 2.2	94-99	028/141	2316	SUBURBAN AT. V8 5.0/5.7	96-99	124/39
1682	WRANGLER L4 2.5 L6 4.0/4.2	87-95	023/92	2317	ESCALADE/C/K SERIES/TAHOE/SILVERADO V8 5.0/5.7	96-00	125/39
1684	LESABRE/REGENCY V6 3.8	91-99	100/121	2320	TUNDRA V6 3.4/4.0	00-06	044/142
1692	PICK UP V6 4.3 V8 5.0/5.7	95-97	114/38	2321	TUNDRA V8 4.7	00-06	045/142
1694	SUBURBAN/ C/K SERIES V8 5.0/5.7	94-95	115/38	2322	TUNDRA V6 3.4	00-04	046/143
1696	PICK UP/SUBURBAN V8 7.4	94-00	116/38	2328	SENTRA L4 2.0	00-01	062/116
1704	323/PROTEGE L4 1.5/1.8	95-98	16/101	2330	MPV VAN V6 2.5	00-01	19/102
1707	B SERIES RAM VAN V6 3.9 V8 5.2/5.9	94-03	061/52	2333	ALTIMA L4 2.4	00-01	063/116
1706	G SERIES VAN EXPRESS V6 4.3 V8 5.7/7	93-96	117/38	2337	C230, C240, C320 V6 2.5/3.0/3.2/3.5	01-06	34/103
1709	DAKOTA V6 3.9 V8 5.2	92-96	062/52	2340	CHEROKEE/WAGONER L6 4.0	91-01	024/92
1721	RANGER/B4000 PICK UP V6 4.0	95-97	101/73	2343	IMPALA V6 3.1/3.4/3.8	99-02	017/21
1726	RANGER/B2300 L4 2.3	95-97	102/73	2355	CIVIC L4 1.7	01-05	034/83
1746	CAMRY/ES300/AVALON V6 3.0	94-99	004/96	2370	ESCALADE/YUKON/TAHOE V8 6.0/6.2	02/00-06	032/23
1750	TERCEL/PASEO L4 1.5	95-99	030/141	2384	NUBRIA L4 2.0/2.4	1999	003/58
1751	240SX L4 2.4	95-98	055/116	2400	S40/V40 L4 1.9	99-04	026/150
1752	MAXIMA /i 130 V6 3.0	95-00	056/116	2403	RAV-4 L4 2.0/2.4	01-05	047/143
1755	TACOMA L4 2.7 V6 3.7	95-04	031/141	2406	ECLIPSE L4 2.4	2000	57/106
1774	TACOMA L4 2.4/2.7 V6 3.4	95-04	032/141	2411	RAV4 L4 2.0	01-03	048/143
1778	TACOMA L4 2.4/2.7 V6 3.4	95-04	033/141	2415	ALTIMA V6 3.5	02-06	064/117
1786	ASTRO/SAFARI VAN V6 3.8	96-97	118/39	2417	MDX/PILOT V6 3.5	03-04	006/114
1788	G-SERIES VAN V6 4.3 V8 5.0	93-96	119/39	2426	Q45/M45 V8 4.5	02-06	003/90
1792	SUBURBAN/TAHOE/ C/K SERIES V8 5.0/5.7	94-99	120/39	2427	SIENNA V6 3.0	01-03	049/143
1815	ODYSSEY/OASIS L4 2.2/2.3	95-98	028/83	2434	CAMRY/ES330/SOLARA V6 3.0/3.3	02-08	050/143
1823	SONATA L4 2.0 V6 3.0	95-98	065/87	2435	CAMRY/ES300 V6 3.0/3.3	02-06	051/143
1841	328/M3 2.5 152 L6 2.0/2.5/3.0	96-07/95-99	030/17	2436	CAMRY/SOLARA L4 2.4	02-08	052/143
1859	RAV4 L4 2.0	96-98	034/141	2437	CAMRY L4 2.4	02-06	053/143
1864	TRACKER/SIDEKICK L4 1.6	92-98	015/135	2438	STRATUS/ECLIPSE L4 2.4	01-06/01-05	065/53
1892	AVENGER/SEBRON V6 2.5	95-00	063/52	2445	AXIOM V6 3.5	02-04	007/90
1897	ELANTRA/TIBURON (ST. & AT.) L4 1.8/2.0	96-01	066/87	2448	LANCER L4 2.0/2.4	02-07	58/106
1906	DIAMANTE V6 3.5	97-04	48/105	2450	IMPREZA H4 2.0	02-03	007/134
1907	MIRAGE L4 1.5/1.8	97-02	49/105	2451	AERIO L4 2.0/2.3	00-07	018/135
1912	RL V6 3.5	96-04	005/14	2459	QX4/PATHFINDER V6 3.5	01-04	65/117
1917	LAND CRUISER L6 4.5	93-97	035/141	2468	MONTERO V6 3.5	01-02	059/106
1918	LAND CRUISER L6 4.5	95-98	036/141	2513	SEVILLE STS/SLS V8 4.6	01-04	033/23
1998	4 RUNNER L4 2.7 V6 3.4	96-02	037/142	2517	EL DORADO V8 4.6	01-02	034/23
2004	CAMRY (26 MT) V6 3.0	97-01	038/142	2556	A4/A4 QUATTRO L4 1.8/2.0	03-06	019/16
2018	EXPLORER/RANGER V6 4.0	97-04	103/73	2557	A4/A4 QUATTRO L4 1.8/2.0	02-06	020/16
2023	SERVING/ECLIPSE L4 2.0	95-97/99	50/105	2562	AZTEK/VENTURE/UPLANDER V6 3.4/3.5	01-05	034/127
2024	TALON/ECLIPSE L4 2.0	95-98/99	51/105	2563	TRAIL BLAZER/ENVOY/RAINIER V8 5.3/6.0	04-05	018/21
2034	A4/PASSAT/54 L4 1.8 V6 2.8	96-04	018/15	2569	ACCORD L4 2.4	03-04	036/83
2042	G SERIES VAN EXPRESS V6 4.3/ V8 5.0/7	96-99/99-02	121/39	2572	CIVIC/HYBRID L4 1.3	03-05	037/84
2044	EXPRESS G SERIES VAN V6 4.3/ V8 5.0/5.7	99-02/96-98	122/39	2574	CIVIC L4 2.0	02-05	038/84
2051	CRV L4 2.0	97-01	029/83	2576	350Z (AT.) V6 3.5	03-06	066/117
2054	Q45 V8 4.1/4.5	96-01	57/116	2577	350Z (ST.) V6 3.5	03-04	067/117
2055	PATHFINDER V6 3.3	96-00	058/116	2590	A4/A4 QUATTRO V6 3.0 3.2	02-11	021/16
2063	MPV V6 3.0	96-98	17/101	2594	X5 01-06 L6 3.0	01-06	032/17
2071	MONTERO SPORT V6 3.0	97-99	52/105	2599	ACCORD 4 CIL. L4 2.4	03-05	039/84
2073	MONTERO SPORT L4 2.4	97-00	53/105	2608	ION 1-2-3 L4 2.0/2.2/2.4	03-04	015/131
2075	PATHFINDER V6 3.3	96-00	059/116	2610	CROWN VICTORIA/LINCOLN TOWN CAR/GRAND MARQUIS V8 4.6	03-04	104/73

CODIGO	APLICACION	AÑOS	DIBUJO /PAGINA	CODIGO	APLICACION	AÑOS	DIBUJO /PAGINA
M1273-26C	ESCORT/TRACER L4 1.8/1.9/2.0	91-02	140/77	LHRP429	CAYENNE/TOUREG/Q7 V6 3.0/3.2/3.6 V8 4.2/4.5/4.8 V10 4.9/5.0	03-10/07-13	43/128
M1274-26N	ESCORT/TRACER L4 1.8/1.9/2.0	91-02/91-99	141/77	LHRP437	PUNTO L4 1.2/1.4 M-T	00-05	006/58
M1557-26N	JETTA/GOLF/CABRIO/CABRIOLET L4 1.8/1.9/2.0	93-02/93-98 95-02/92-93	017/149	LHRP444	ALMERA 1.8/2.0i 16V	00-09	084/119
M1850-26C	GRAND VOYAGER/TOWN COUNTRY/CARAVAN/VOYAGER L4 2.4 /V6 3.0/3.3/3.8	96-00	078/54	LHRP451	306 L4 1.6	98-02	104/121
M1862-26C	CARAVAN/VOYAGER/TOWN COUNTRY L4 2.4 V6 3.0/3.3/3.8	96-00	079/54	LHRP470	CRUZE L4 1.6/1.8 16V.	09-13	149/42
M2138-26C	MUSTANG V6 3.8/3.9	97-04	142/77	LHRP480	207/307/PARTNER L4 1.6	98-00	105/121
M2139-26C	MUSTANG V8 4.6	97-04	143/77	LHRP487-2	LUPO/POLO/GOL/CROSS FOX 1.2/1.4	05-12	021/150
M2140-26C	ESCORT Zx2 L4 2.0	00-00	144/77	LHRP488-1	GOL/LUPO/CROSS FOX L4 1.4/1.6/1.8/1.9	05-09	022/150
M2141-26C	F-SERIES/EXPEDITION/LOBO V8 4.2/4.6	97-98 01-02	145/78	LHRP499-26M	MONDEO L4 2.0/2.2 TDCi/TDDi	00-04	132/76
M2258-26P7	FREESTAR/WINDSTAR/MONTEREY V6 3.0/3.8/3.9/4.2	94-97 95-03	146/78	LHRP500	MONDEO V6 2.5/3.0 A.T.	00-02	133/76
M2265-26N	JETTA/GOLF/TT/QUATRO L4 1.8/1.9/2.0 V6 2.8	00-10	018/149	LHRP515	HILUX L4 2.5	2004	068/145
M2274-26C	CIVIC/EL L4 1.5/1.6	92-00	012/015	LHRP527	X-TRAIL L4 2.0 / V6 2.5	08-11	085/119
M2274-26N	CIVIC/EL L4 1.5/1.6	92-00	013/015	LHRP532	H-100 L4 2.5 MOTOR DIESEL	06-11	074/88
M2296-26N	FOCUS L4 2.0/2.3	00-07	147/78	LHRP555	ACCORD/CROSS TOUR L4 2.4	08-14/12-14	059/86
M2311-26N	CARAVAN/GRAND CARAVAN/VOYAGER/TOWN&COUNTRY V6 3.3/3.8	01-04	080/054	LHRP556	FIT L4 1.5	09-13	060/86
M2340-26C	CHEROKEE/WAGONER L6 4.0	91-01	029/93	LHRP557	ODYSSEY L4 2.4	10-13	061/86
M2362-26C	SX 2.0/NEON L4 2.0	00-04	081/054	LHRP568	X6 L6 3.0 V8 4.4	10-13	036/17
M2363-26C	NEON/SX 2.0	03-04	082/055	LHRP583	X5 L6 3.0 V8 4.4	07-13	037/18
M2363-26N	NEON/SX 2.0 L4 2.0	00-04	083/055	LHRP589-1	GRAND I10 1.0/1.6	15-16	077/54
M2420-26C	CHEVY C2/CONFORT/MONZA 1.2/1.4/1.6	98-04	151/042	LHRP593	BOXTER/911 H6 2.7/3.2/3.4/3.6	00-06/99-04	044/128
M2420-26N	CHEVY C2/CONFORT/MONZA 1.2/1.4/1.6	98-04	152/042	LHRP596	TIGUAN L4 1.4/2.0	07-14	020/150
M2481-26P5	LIBERTY V6 3.7	02-06	030/93	LHRP614	OPEL MERIVA L4 1.4/1.6/1.8	03-10	146/042
M2818-26P7	EXPEDITION/F-SERIES/MARK LT/LOBO/NAVIGATOR V6 4.2 V8 4.6/5.4	05-08	148/78	LHRP624-16	AVEO L4 1.6/16V	09-11	147/042
M2845-26C	NEON/SX 2.0 L4 2.0	2005	084/055	LHRP665-2	Lx35 L4 2.0	09-15	076/88
M2910-26P5	LIBERTY V6 3.7	02-06	031/93	LHRP703	MONDEO V6 2.5/3.0 A.T.	00-02	134/76
M6031-26N	ATOS L4 1.0i	01-04	085/55	LHRP704	MONDEO V6 2.5/3.0 A.T.	00-02	135/76
M6039-26C	CHEVY C2/CONFORT/MONZA 1.4/1.6	98-04	153/042	LHRP710-2	AVANZA L4 1.5	08-12	69/145
M6039-26N	CHEVY C2/CONFORT/MONZA 1.4/1.6	98-04	154/043	LHRP733	PANDA L4 1.4i	12-15	007/58
M6118-26C	VOYAGER/TOWN & COUNTRY/CARAVAN L4 2.4 V6 3.8	96-00	086/55	LHRP810	TSURU II L4 1.6	88-91	086/119
M7023-26N	CORSA/TORNADO 1.8 16V. ALUMINIO MECÁNICO	04-06	155/43	LHRP841	3 L4 1.6/1.8	10-13	29/103
M7024-26C	ASTRA L4 1.8/2.0 16V	91-01	156/43	LHRP946	RANGER 3.2L SUPER DIESEL	11-15	136/77
M7024-26N	ASTRA L4 1.8/2.0 16V	02-08	157/43	LHRP15010	PUNTO III/GRANDE 1.3	05-08	008/58
M7040-26N	ATOS L4 1.0i	05-12	087/55	TRACTOCAMIÓN ALUMINIO-PLÁSTICO 152			
M13272-26N	TIGUAN L4 1.4/2.0	10-15	019/150	POST-ENFRIADORES 157			
MTc8238-52P5	CASCADIA L6 12.8/14.8	07-08	137/77				
MT2311-26N	CARAVAN/GRAND CARAVAN/VOYAGER/TOWN&COUNTRY V6 3.3/3.8	01-04	088/055				
OL0010-24M	CHEVY/JOY POP 1.1/1.6 16V. ALUMINIO MECÁNICO	94-03	160/43				
OL0100-24M	CORSA/TORNADO 1.8 16V. ALUMINIO MECÁNICO	04-06	161/43				
PG-009	206 L4 1.1/1.4/1.6	98-04	106/121				
RT0040-24M	MEGANE L4 1.6/2.0 ALUMINIO MECÁNICO	06-09	006/130				
ST0010-24M	IBIZA/CORDOBA L4 1.8/2.0 ALUMINIO MECÁNICO	99-04	005/134				
1557-26N	GOLF/JETTA/CABRIO/CABRIOLET L4 1.8/1.9/2.0 AM	92-02/95-02	017/149				
1557-32M	GOLF/JETTA L4 1.8/1.9/2.0 ALUMINIO MECÁNICO	93-99	024/150				
2265-24M	GOLF/JETTA L4 1.8/1.9/2.0 V6 2.8 ALUMINIO MECÁNICO	99-05	025/150				
7024-24M	ASTRA/ZAFIRA 2.0/2.2 16V ALUMINIO MECÁNICO	02-08	158/43				
7024-32M	ASTRA/ZAFIRA 2.0/2.2 16V. ALUMINIO MECÁNICO	02-08	159/43				
LHRP025-2R	MONDEO FORD L41.8/2.0/2.5	00-02	129/76				
LHRP099	PARTNER/307 M/T L4 2.0	04/02-03	101/121				
LHRP110-16MT	MEGANE/CLIO/SCENIC II L4 1.6	02-06	003/130				
LHRP0133-16MT	PALIO 1.2i 16V	2004	009/58				
LHRP0152-26MT	CORSA/TORNADO 1.4 16V.	04-06	148/42				
LHRP0158-26MT	ATOS V6 3.8	00-04	076/54				
LHRP-1065-16	TIDDA/VERSA/NOTE L4 1.6/1.8	12-15	087/119				
LHRP169	L200 (TRITON) V6 3.5	05-06	066/107				
LHRP173	TIIDA L4 1.6/1.8	07-13	081/118				
LHRP176	ODYSSEY V6 3.5 A.T.	05-06	057/86				
LHRP184	306 M.T./A.T. L4 1.8/1.9/2.0	08-12	120/121				
LHRP185	ACCENT/VERNA L4 1.6i	1999	073/88				
LHRP189-26AT	HILUX L4 2.7	05-08	065/145				
LHRP205-2R	FIESTA/IKON FORD L4 1.6	00-02	130/76				
LHRP234	HILUX L4 2.5	2004	066/145				
LHRP269-2	KANGOO L4 1.5/1.9	00-03	004/130				
LHRP287	MICRA/K12 L4 1.0/1.2/1.4	05-07	082/119				
LHRP289	307/C4 L4 1.6/1.8/2.0	00-08	001/58				
LHRP291	206/C4 MT L4 1.6	2004	103/121				
LHRP293	MEGANE/SCENIC L4 1.6	02-06	005/130				
LHRP305-2R	PATHFINDER V6 4.0 V8 5.6	2005	083/119				
LHRP348-2R	MONDEO FORD L4 1.8	2007	131/76				
LHRP349-1R	ACCORD/ROX V6 3.5	08-12/13	058/86				
LHRP373	HILUX L4 2.5	2004	067/145				
LHRP404	OPEL MERIVA 1.7 DTI	03-10	145/42				

INFORMACIÓN FINAL

PHAR presenta la información de este catálogo como un servicio a sus clientes y demás usuarios.

Sin embargo debido a que **PHAR** proporciona información de una industria en constante crecimiento, no podemos garantizar la exactitud o confiabilidad de la información contenida en este catálogo.

Le recomendamos encarecidamente que siempre verifique la información específica sobre los números de las piezas.

Provedora de Herramientas y Accesorios para Radiador S.A. de C.V.

Todos nuestros paneles y radiadores están elaborados con materias de primera calidad, garantizando así su perfecto funcionamiento por periodo de 1 año* a partir de la fecha de nuestra factura.

*Considerando la siguiente escala:

MESES	%
0-6	100
7	90
8	80
9	70
10	60
11	50
12	40

NO procederá en los siguientes casos:

- A)** Cuando el producto presente golpes físicos y/o defectos por mal uso, negligencia o condiciones de operación mayores a las condiciones para las cuales el producto fue diseñado.
- B)** Cuando presente ataques de productos químicos, gases, líquidos o temperaturas extremas.
- C)** Cuando sea reparado o alterado fuera de **PHAR S.A. de C.V.** sin previa autorización.

PHAR S.A. de C.V. se obliga por esta garantía a reparar, reemplazar o cubrir únicamente el valor del producto en cuestión.

En ningún caso se cubrirá materiales, mano de obra o partes suministradas, ni daños incidentales o consecuencias derivadas de ninguna garantía.

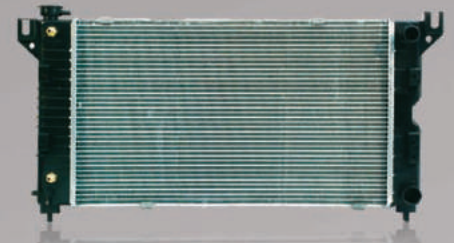

ELECTRÓLISIS

La Electrólisis es de las causas más importantes de desperfectos en el radiador, se provoca cuando el ph es demasiado elevado o cuando un cable eléctrico se encuentra mal aterrizado a tierra o en mal estado. Para prevenir, realizar la prueba para detectar corriente eléctrica circulando a través del radiador. (Use un voltímetro para realizar la prueba).



CONTAMINACIÓN Y ADITIVOS

La contaminación y los aditivos pueden obstruir el paso y reducir la capacidad de transferencia térmica. El uso de anticongelante concentrado o la mezcla de dos tipos de estos producirá sedimentos en el sistema. Utilizar una mezcla de 50% de agua desfilada y 50% de anticongelante concentrado o un anticongelante con la mezcla preparada desde el fabricante.



NIVEL DEL PH

Un nivel inadecuado de ph en el sistema provocará la calcificación de los tubos, que causara una disminución de la circulación y aumentará la temperatura. El objetivo del mantenimiento preventivo es evitar esta situación.



TAPÓN DE PRESURIZACIÓN

El tapón mantiene constante la presión del sistema para evitar que el líquido llegue a ebullición, también debe controlar la circulación del líquido hacia el tanque de sobre flujo. Revisar el buen estado del tapón, se recomienda reemplazar al instalar un radiador nuevo.



REVISIÓN DEL TERMOSTATO

El termostato se debe reemplazar durante los mantenimientos en los cuales se cambia el anticongelante del sistema. La instalación del termostato con el rango de temperatura adecuado se debe realizar para optimizar el rendimiento del radiador y el del combustible.



DESGASTE EXTERIOR EXCESIVO

El desgaste exterior excesivo del radiador se debe al paso del tiempo y a los residuos del camino. El daño de las aletas reducirá la capacidad de enfriamiento. En estos casos reemplazar el radiador.



La garantía NO aplica en las siguientes condiciones.

- 1 Golpes físicos
- 2 Defectos por mal uso y/o instalación
- 3 Condiciones de operación mayores para las cuales el producto fue diseñado
- 4 Ataques de productos químicos o temperaturas extremas
- 5 Electrólisis
- 6 Cuando sea reparado por el cliente.
- 7 No usar anticongelante, o que sea de mala calidad.

