

Accessory

HYPRO SERIES

Spray Gun

3381-0043L
3381-0043

Form L-0346
3/07



3381-0043L
Specifications

Max. Pressure:600 PSI
Max. Capacity:11 gpm
Barrel Length:18"
Port:3/8" and 1/2" Hose Barb

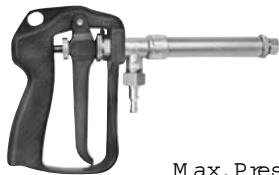

3381-0043
Specifications

Max. Pressure:600 PSI
Max. Capacity:11 gpm
Barrel Length:7"
Port:3/8" and 1/2" Hose Barb

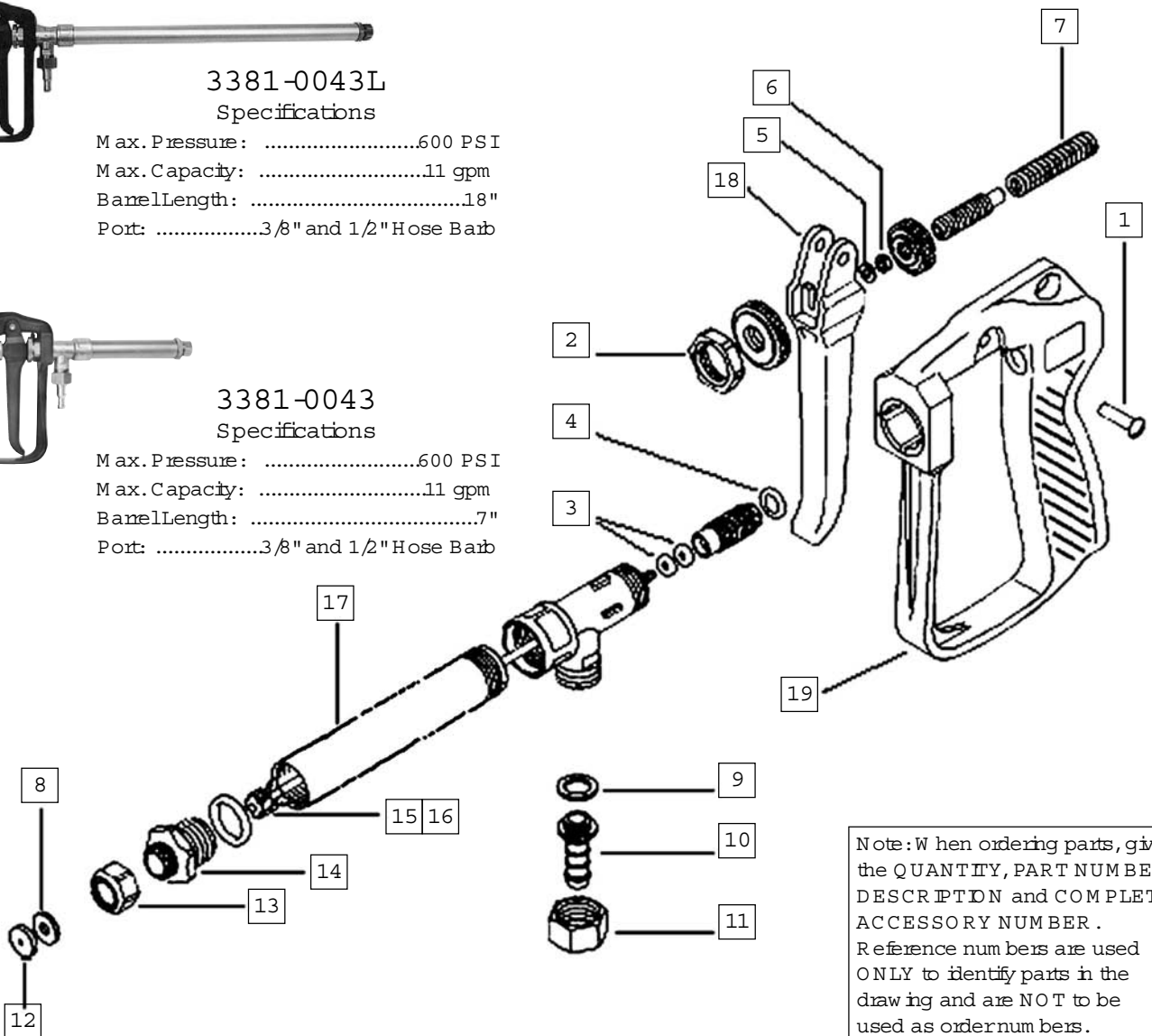

Note: When ordering parts, give the QUANTITY, PART NUMBER, DESCRIPTION and COMPLETE ACCESSORY NUMBER. Reference numbers are used ONLY to identify parts in the drawing and are NOT to be used as order numbers.

These parts are ONLY available as 3430-0435 KIT

Ref. No.	Part No.	Description
1	9920-35.1508.4	Pin
2	9920-35.301.27	Nut
3	9920-27.602.39	O-ring (quantity: 2)
4	9920-260.602.14	O-ring
5	9920-35.1506.20	Washer
6	9920-27.301.28	Nut
7	9920-27.1003.25	Spring
8	9920-27.601.34	Gasket
9	9920-162.601.6	Gasket

Ref. No.	Part No.	Description
10	9920-162.1502.2	Hose Barb
11	9920-162.605.21	Ring Nut
12	AM T-15015	Standard Nozzle Ceramic Tip 1.5 (other nozzles available, see chart on back)
13	9920-27.605.48	Ring Nut
14	9920-35.1701.11	Brass Reducing Nipple
15	9920-31.204.36	Rod & Core for 7" Barrel
16	9920-32.204.37	Rod & Core for 18" Barrel
17	9920-35.1703.67	18" Barrel
18	9920-35.902.9	Trigger
19	9920-35.802.22	Handle

Performance Chart for Model 3381-0043L and Model 3381-0043 Spray Guns

SPRAY GUN NOZZLES FOR 3381-0043 AND 3381-0043L GUNS

Part no.	Orifice	Performance	45 PSI		100 PSI		150 PSI		200 PSI		300 PSI		450 PSI		600 PSI	
			Cone	Straight	Cone	Straight	Cone	Straight	Cone	Straight	Cone	Straight	Cone	Straight	Cone	Straight
AMT-15010 replaces 9920-61.1802.45	1.0mm	GPM spray angle throw, ft	0.24 30° 3.2	0.24 - 8.2	0.35 30° 4.9	0.37 - 13.0	0.40 40° 6.5	0.45 - 18.0	0.53 40° 6.5	0.60 - 18.5	0.57 40° 6.5	0.60 - 19.5	0.70 40° 7.2	0.75 - 21.0	0.83 38° 8.2	0.90 - 23.0
AMT-15012 replaces 9920-61.1802.46	1.2mm	GPM spray angle throw, ft	0.35 32° 3.9	0.38 - 9.8	0.55 35° 5.5	0.55 - 14.5	0.60 42° 7.2	0.65 - 20.0	0.80 42° 7.2	0.93 - 21.0	0.88 42° 7.2	0.90 - 22.0	1.10 40° 8.2	1.20 - 23.5	1.30 40° 8.2	1.40 - 25.5
AMT-15015 replaces 9920-61.1802.47	1.5mm	GPM spray angle throw, ft	0.40 32° 3.9	0.50 - 11.5	0.62 35° 6.5	0.80 - 14.5	0.73 45° 8.2	0.93 - 23.0	0.95 45° 8.2	1.25 - 24.0	1.00 42° 8.2	1.30 - 24.5	1.30 42° 8.2	1.70 - 26.0	1.50 42° 10.0	1.95 - 28.0
AMT-15018 replaces 9920-61.1802.48	1.8mm	GPM spray angle throw, ft	0.50 40° 4.9	0.75 - 13.0	0.73 42° 6.5	1.20 - 16.5	0.85 50° 8.2	1.35 - 26.0	1.15 45° 8.2	1.75 - 27.0	1.20 50° 8.2	1.90 - 28.0	1.60 48° 9.8	2.30 - 31.0	1.75 48° 10.0	2.80 - 33.0
AMT-15020 replaces 9920-61.1802.55	2.0mm	GPM spray angle throw, ft	0.73 40° 4.9	1.10 - 14.5	1.05 42° 6.5	1.60 - 19.5	1.30 55° 8.2	1.90 - 29.5	1.50 55° 8.2	2.40 - 30.5	1.60 55° 8.2	2.50 - 31.0	1.90 53° 9.8	3.00 - 34.0	2.20 50° 10.0	3.50 - 36.0
AMT-15023 replaces 9920-61.1802.68	2.3mm	GPM spray angle throw, ft	0.90 40° 4.9	1.40 - 16.5	1.30 42° 6.5	1.90 - 24.5	1.50 55° 10.0	2.30 - 32.0	2.00 55° 10.0	3.20 - 35.0	2.10 55° 10.0	3.30 - 36.0	2.70 53° 9.8	4.10 - 38.0	3.10 51° 10.5	4.80 - 39.0
9920-35.1802.56	4.0mm	GPM throw, ft														

* Figures are guidelines for vertical throw. Performance will vary with wind velocity.

Repair Parts: O-ring Repair Kit 3430-0435 is available to replace all o-rings within guns.



HYPRO®

**Pentair Water
SPRAY GROUP**

375 Fifth Avenue NW • New Brighton, MN 55112
Phone: (651) 766-6300 • 800-424-9776 • Fax: 800-323-6496
www.hypropumps.com