

Dec 12th, 3:00 PM

4th International Conference on Events (ICE) Conference Proceedings

Mathilda van Niekerk
University of Central Florida, mathilda.vanniekerk@ucf.edu

Ubaldo (Dino) Couto
Institute for Tourism Studies, dino@ift.edu.mo

Find similar works at: <https://stars.library.ucf.edu/ice2017>
University of Central Florida Libraries <http://library.ucf.edu>

This Event is brought to you for free and open access by the Rosen College of Hospitality Management at STARS. It has been accepted for inclusion in 4th International Conference on Events (ICE) 2017 by an authorized administrator of STARS. For more information, please contact STARS@ucf.edu.

van Niekerk, Mathilda and Couto, Ubaldo (Dino), "4th International Conference on Events (ICE) Conference Proceedings" (2017). *4th International Conference on Events (ICE) 2017*. 11.
<https://stars.library.ucf.edu/ice2017/2017/tuesday/11>



CONFERENCE PROCEEDINGS



BEYOND THE
waves

4th International Conference on Events (ICE)
December 12-14 2017



UCF

Rosen College of
Hospitality Management

UNIVERSITY OF CENTRAL FLORIDA

UCF, Orlando, Florida, USA

Conference proceedings of Beyond the Waves: The 4th International Conference on Events (ICE2017)

Editors: Mathilda Van Niekerk & Ubaldino Couto
Production secretary: Wendy Tang

Rosen College of Hospitality Management
University of Central Florida
9907 Universal Boulevard
Orlando
Florida 32819
United States of America



Rosen College of Hospitality Management

UNIVERSITY OF CENTRAL FLORIDA

Published December 2017 by Rosen College of Hospitality Management

© Rosen College of Hospitality Management 2017

All rights reserved. No part of this publication may be reproduced, stored in a retrieval system, or transmitted, in any form or by any means, mechanical, photocopying, recording or otherwise, without the prior permission of the publisher.

Beyond the Waves: The 4th International Conference on Events (ICE2017)

12-14 December 2017

Rosen College of Hospitality Management
University of Central Florida
9907 Universal Boulevard
Orlando
Florida 32819
United States of America

Organised by



Co-organised by



Support by



Topgolf



This conference is dedicated to all researchers who tirelessly work to advance our knowledge, and to practitioners in festivals and events who put together great shows for our enjoyment and needs.

This conference also reaffirms the international collaborations and years of friendship built across borders, oceans and cultures.

We count on you to uphold the tradition and to create a memorable experience together.

Previous ICE conferences:

- Making Waves, Bournemouth University, United Kingdom, 3-5 July 2013
- Changing Gear, Sheffield Hallam University, United Kingdom, 2-4 July 2014
- Making Waves in Macao, Institute for Tourism Studies, Macao, 7-9 September 2015

Contents

Contents.....	4
Foreword.....	7
Welcome from conference hosts.....	8
Welcome from Bournemouth University	9
Welcome from Institute for Tourism Studies (IFT)	10
About us.....	11
About ICE2017	13
Programme	14
Introductory keynote – How to go beyond the waves: Moving from hedonic to utilitarian events....	19
Abraham Pizam	19
Keynote – The evolution of festivals & events in a changing world	20
Steven Wood Schmader, CFE	20
Keynote – Introduction to OCCC, what is happening in the MICE Industry? The importance of working with educational institutions	21
Kathleen Canning	21
Keynote – Making sense of our business engagement: illusions, aspirations and achievements	22
Rhodri Thomas.....	22
Keynote – Designing the event management curriculum for the future	23
Donald Getz.....	23
Keynote – Taking events and festival journals to SSCI status.....	24
Fevzi Okumus	24
Research and Grants Panel	25
Robertico Croes.....	25
Leonardo A. N. Dioko	25
Karin Weber	Error! Bookmark not defined.
Rhodri Thomas	Error! Bookmark not defined.
Industry Panel	26
Suzanne Neve.....	26
Jason Siegel	26
Adrienne Six	26
Kirk Wingerson.....	26
Curriculum Panel.....	27
Deborah Breiter Terry.....	27
Ubaldo Couto	27
Caroline Jackson.....	27

Kelly Semrad	27
Editors Panel	28
Alan Fyall	28
Judith Mair	28
Fevzi Okumus	28
Rhodri Thomas	28
Abstracts and Extended Abstracts	29
AUTHENTICITY AND CULTURAL SUSTAINABILITY AT THE OSUN OSOGBO FESTIVAL, NIGERIA	29
FESTIVAL IMAGE: RELATIONSHIPS BETWEEN THE DIMENSIONS OF SATISFACTION, IMAGE, AND SOURCES OF INFORMATION OF THE BRAZILIAN BEER FESTIVAL.....	33
HOW DO PLANNERS AND ATTENDEES EXPERIENCE A CONVENTION IN REAL TIME?	37
THE FUTURE OF FESTIVAL DESIGN IN AN EMERGING HAPPINESS ECONOMY	41
IMPORTANT CONTEMPORARY MOTIVATORS AND INHIBITORS IN ASSOCIATION DELEGATES' CONFERENCE ATTENDANCE CHOICE	44
EFFICIENT USE OF DATA RESOURCES USING THE EXAMPLE OF MEETINGS AND EVENTS INDUSTRY MANAGEMENT IN POLAND	47
THE "ALE" IN FEMALE: THE FEMININE VOICE AT A CRAFT BEER FERMENTATION FEST.....	52
SPENDING BEHAVIOR AND MUSIC INTEREST IN SIDS: THE CASE OF THE ARUBA SUMMER MUSIC FESTIVAL.....	56
THE POWER OF EWOM FOR MUSIC FESTIVALS IN THE EXPERIENCE ECONOMY	60
"THIS BLOWS!" – THE IMPACT OF EXTREME WEATHER ON SPORTING EVENTS: THE CASE OF THE CAPE TOWN CYCLE TOUR	63
HOW TO SECURE FUNDING FOR A CONVENTION CENTER AND CVBS: THE CASES OF THE STATE OF FLORIDA AND JAPAN.....	66
A BOURDIEUSIAN CRITIQUE OF EVENT PROFESSIONALISATION	71
THE GESTALT OF EVENT CREATIVITY?.....	73
FESTIVAL SUSTAINABILITY: A LONG-TERM HOLISTIC PERSPECTIVE.....	75
CARNIVAL EVENT EXPERIENCE IN BRAZIL	77
SCALE DEVELOPMENT TO MEASURE THE CO-CREATION EXPERIENCE, AND RESULTING VALUE IN ART EXHIBITIONS	80
A STUDY OF THE EMOTIONS EXPERIENCED BY ATTENDEES AND NON-ATTENDEES: EVIDENCE FROM THE TOUR DE FRANCE.....	83
FOSTERING COMMUNITY SUPPORT FOR MEGA EVENTS: A NARRATIVE INQUIRY OF SOCIAL IMPACTS EXPERIENCED AS A RESULT OF HOSTING THE FIFA 2010 WORLD CUP IN CAPE TOWN, SOUTH AFRICA	86
THE ECLECTIC ECONOMICS OF MUSIC FESTIVALS OCCURRING IN SMALL ISLAND DESTINATIONS..	89
THE ROLE OF SOCIAL INFLUENCE ON EXPO ATTENDEE BEHAVIOR UTILIZING VIDEO TRACKING	92

A LONGITUDINAL STUDY OF THE LONG-TERM EVENTS IMPACTS FOR WEYMOUTH UK FROM HOSTING EVENTS FOR LONDON 2012	95
DO MEGA EVENTS CAUSE CHANGE IN COUNTY OR DESTINATION IMAGE? THE CASE OF 2016 OLYMPIC GAMES IN BRAZIL	98
Full papers.....	102
DEVELOPING LEADERS FOR A COLLABORATIVE WORKFORCE: THE CHALLENGE FOR EVENT MANAGEMENT TRAINING IN HIGHER EDUCATION	102
SUPPORT FOR GREEN CONFERENCES ONLY LIP SERVICE – SO WHAT CAN BE DONE?.....	111
HOLIDAY EFFECTS ON THE STOCK PRICE OF THE AMUSEMENT PARK AND ATTRACTIONS INDUSTRY IN THE UNITED STATES.....	126
PARTICIPATING AND NON-PARTICIPATING RESIDENT PERCEPTIONS AND ATTITUDES TOWARDS MACAO’S DRUNKEN DRAGON FESTIVAL	133
THREATS TO SAFEGUARDING TRADITIONAL CULTURAL FESTIVALS IN MACAO	144
HOSTING THE SUMMER OLYMPICS ASSOCIATED WITH WORSENING INCOME INEQUALITY—A PRELIMINARY ANALYSIS.....	156
TOWARD UNSUPERVISED MACHINE LEARNING TECHNIQUE TO DISCOVER THE KEY TOPICS INFLUENCE EXHIBITION VISITOR ENGAGEMENT IN SOCIAL MEDIA: A CASE STUDY FROM TAIWAN	164
RESEARCH ON THE DESTINATION TOURIST TRUST AND ITS INFLUENCE ON TOURISM IMAGE	174
IS HIGHER ATTENDANCE, THE BETTER? – EXAMINING THE IMPACTS OF MEETING SIZE ON ATTENDEES’ PSYCHOLOGICAL RESPONSES AND CONSEQUENCE BEHAVIOR.....	195
THE ROLE OF AN OFFICIAL WEBSITE FOR INTERNATIONAL CONVENTION CENTERS IN E-MARKETING ERA	206
CORPORATE SOCIAL RESPONSIBILITY AND ITS IMPACT ON EMPLOYEE ORGANIZATIONAL IDENTIFICATION AND ORGANIZATIONAL COMMITMENT: A PERSPECTIVE OF CHINESE BRAND HOTEL EMPLOYEES	215
OVERWHELMING OR EXCITING: AN ACTION STUDY OF CONFERENCE ATTENDEE EXPERIENCE....	235

Foreword

What makes you happy in life? A question that I have been asking myself very often the past few years. Is it your family? Your work? Surely, we all will have different answers, but I believe that for many of us here attending ICE 2017, it is the excitement that events bring to our lives.

For some, it might be walking into a stadium, smelling the fresh cut grass and feeling the anticipation of the crowd. For others, opening the doors to the convention center and seeing the faces as different attendees enter through the doors. Maybe your happy place is being at a music festival and dancing and singing with your favorite artist. We all love creating events, pushing ourselves to the limits to create an event that will “wow” the people. Seeing our clients being happy and satisfied, that is what makes us happy.

ICE 2017 was created with love and passion, but it will depend on you how much you are going to enjoy it. This is the time to see friends, make new friends and share the knowledge and experiences that we have gained from doing research. Enjoy each and every session with us, experience Orlando through the social activities we have planned and laugh and relax while you are visiting the happiest place on earth.

Enjoy the hospitality of Rosen College and ICE 2017 and if you need anything we are here to assist you.



Mathilda Van Niekerk
Chair of the Organizing Committee, ICE2017

Welcome from conference hosts

You are about to embark on an exciting adventure at the Beyond the Waves: the 4th International Conference on Events (ICE2017).

On behalf of the Organizing Committee, welcome. It is our pleasure to host you at UCF's Rosen College of Hospitality Management; the largest facility ever built for hospitality management education and the largest such program in the country. The conference provides a dynamic, interactive and international platform for academics and practitioners to explore and debate the latest issues and trends in event research and practice.

We received 50 abstracts for oral and poster presentations and were very pleased with the number of high-quality proposals submitted. The reviewing process involved 50 recognized international scholars as well as members of the Executive, Organizing and Scientific Committees. We sincerely appreciate the authors and reviewers who invested significant time and effort to provide and evaluate topics for this conference. We would also like to thank the committee members for their contributions.

In addition to the keynote presentations, parallel sessions, industry panels and research reviews, please remember to join us for our excursions to the Orange County Convention Center, Top Golf, the Amway Center, Planet Hollywood at Disney Springs and Cirque du Soleil "La Nouba", which takes its final bow at the end of December.

We hope you enjoy your time in Orlando, which welcomed a record-breaking 66 million visitors in 2016. Thank you for joining us and we look forward to our discussions!



Dr Abraham Pizam
Dean
Rosen College of Hospitality Management

Conference Co-Chair, ICE2017



Dr Robertico Croes
Associate Dean: Administration & Finance
Rosen College of Hospitality Management

Conference Co-Chair, ICE2017

Welcome from Bournemouth University

On behalf of Bournemouth University I would like to wish Rosen College of Hospitality Management, UCF, Orlando, Florida every success in organising the 4th International Conference on Events (ICE2017). Following the success of the first International Conference on Events in Bournemouth and the second in Sheffield, the third at the Institute for Tourism Studies, Macao, the event aims to enhance further the ever-growing academic domains of event studies and event management which continue to offer exciting diversity for research and education as evidenced by the range of conference themes. I am sure the academic and industry keynote speakers will set a stimulating and reflective tone to the conference and encourage debate and collaboration.

I would like to take this opportunity to thank our academic partners – Rosen College of Hospitality Management at the University of Central Florida, USA; the Institute for Tourism Studies, Macao; Griffith University, Australia; and other supporters from the industry.

Special thanks must go to the organisers of this conference, Dr Abraham Pizam, Dr Robertico Croes, Dr Mathilda Van Niekerk, Dr Jae Yeon Hahm, Dr Marissa Orłowski, Dr Alan Fyall, Ubaldino Couto, Dr Julie Whitfield and Dr Caroline Jackson.

We all know that without their effort and commitment as the Organising Committee, ICE2017 would not have happened.

Have a great experience at ICE2017!



Professor Stephen Tee
Executive Dean, Faculty of Management
Bournemouth University, United Kingdom

Co-Organiser, ICE2017

Welcome from Institute for Tourism Studies (IFT)

On behalf of the Institute for Tourism Studies (IFT), I'd like to welcome all delegates to Beyond the Waves: the 4th International Conference on Events (ICE2017). I wish to extend my gratitude to the host, Rosen College of Hospitality Management at the University of Central Florida, as well as co-organiser Bournemouth University. I would also like to take this opportunity to thank the committee members Dr Abraham Pizam, Dr Robertico Croes, Dr Mathilda Van Niekerk, Dr Jae Yeon Hahm, Dr Marissa Orlowski, Dr Alan Fyall, Dr Julie Whitfield, Dr Caroline Jackson and Ubaldino Couto for their hard work and dedication in putting together what will be another successful, inspiring and thought-provoking meeting.

Looking at the previous conferences, from Making Waves in Bournemouth in 2013 to Making Waves in Macao in 2015, and this time Beyond the Waves in Orlando, I am looking very forward to how far the waves will take us next. Many collaborations were made, friendship rekindled, and a strong network within event studies strengthened through the ICE conferences. Finally, I thank you for your continuous support and participation in the conference, particularly the paper reviewers, session chairs, panellists and keynote speakers. I am sure the research work presented in the conference, the keynote speeches, site visits and social activities will be beneficial and stimulating for all.

I wish every success for the conference and everyone a fruitful, memorable and enjoyable time. Have a great one!



Dr Fanny Vong
President
Institute for Tourism Studies, Macao

Co-Organiser, ICE2017

About us

ICE COMMITTEE

Julie Whitfield

Founder, Bournemouth University, UK

Caroline Jackson

Founder, Bournemouth University, UK

Ubaldino Couto

2015 Host, Institute for Tourism Studies, Macao

Mathilda van Niekerk

2017 Host, University of Central Florida, USA

ORGANISING COMMITTEE

Abraham Pizam

Co-Chairperson, University of Central Florida, USA

Robertico Croes

Co-Chairperson, University of Central Florida, USA

Mathilda van Niekerk

Chair, Organising Committee, University of Central Florida, USA

Jae Yeon Hahm

Co-Chair, Organising Committee, University of Central Florida, USA

Marissa Orlowski

Co-Chair, Organising Committee, University of Central Florida, USA

Alan Fyall

Chair, Scientific Committee, University of Central Florida, USA

Murat Kizildag

Co-Chair, Scientific Committee, University of Central Florida, USA

Ubaldino Couto

ICE Committee, Institute for Tourism Studies, Macao

Julie Whitfield

Founder, Bournemouth University, UK

Caroline Jackson

Founder, Bournemouth University, UK

SCIENTIFIC COMMITTEE

Alan Fyall, *University of Central Florida, USA*

Allan Jepson, *Hertfordshire University, UK*

Arend Hardorff, *NHTV Breda University of Applied Science, Netherlands*

Asli Tasci, *University of Central Florida, USA*

Caroline Jackson, *Bournemouth University, UK*

Charles Arcodia, *Griffith University, Australia*

Daniel Turner, *University of the West of Scotland, UK*

Deborah Breiter, *University of Central Florida, USA*

Donald Getz, *University of Calgary, Canada*

Emma Wood, *Leeds Beckett University, UK*

George Fenich, *East Carolina University, USA*

Ivana Rihova, *Edinburgh Napier University, UK*

Jee Yeon Hahm, *University of Central Florida, USA*

Judith Mair, *University of Queensland, Australia*

Julie Whitfield, *Bournemouth University, UK*

Karin Weber, *Hong Kong Polytechnic University, Hong Kong*

Kelly Semrad, *University of Central Florida, USA*

Krzysztof Celuch, *Warsaw School of Tourism and Hospitality Management, Poland*

Leonardo Dioko, *Institute for Tourism Studies, Macao*

Liu Chunzhang, *Donghua University, China*

Manuel Rivera, *University of Central Florida, USA*

Marisa de Brito, *NHTV Breda University of Applied Science, Netherlands*

Mathilda van Niekerk, *University of Central Florida, USA*

Miguel Moital, *Bournemouth University, UK*

Rhodri Thomas, *Leeds Beckett University, Leeds, UK*

Richard Shipway, *Bournemouth University, UK*

Robertico Croes, *University of Central Florida, USA*

Sevil Sonmez, *University of Central Florida, USA*

Sherry Tan, *Institute for Tourism Studies, Macao*

Sunny Lee, *University of South Australia, Australia*

Ubaldo Couto, *Institute for Tourism Studies, Macao*

Vern Biaett, *High Point University, USA*

About ICE2017

The 4th International Conference on Events (ICE) 2017: Beyond the Waves, will take place from 12-14 December 2017 at Rosen College of Hospitality Management, Orlando, Florida, USA. Rosen College of Hospitality Management is a centre of excellence in hospitality, tourism and event research and education. The conference provides a dynamic, interactive and international platform for academics and practitioners to explore and debate the latest issues and trends in event research and practice. The conference offers a unique networking opportunity for scholars, industry experts, practitioners, government officials and policy makers to exchange ideas and information, and explore how to enhance research and knowledge sharing through partnerships.

THEMES

A key feature of the conference will be the inclusion of a number of keynote addresses and panel discussions on issues concerning events. In addition, the following themes will be offered during breakout sessions in the form of presentations and discussions:

- Management models for events and festivals
- Safety and security for events and festivals
- Smart events and festivals
- Innovations in events and festivals
- Information Communication Technology for events and festivals
- Environmental sustainability for events and festivals
- Corporate social responsibility (CSR)
- Supply side and demand side approaches
- Stakeholder centric approach
- Integrated and environmental sustainable approach for events and festivals
- Strategic planning processes for events and festivals
- Developing events and festivals as tourist attractions
- Healthy food choices during events
- Policies and politics of events
- Events education and professionalization
- Creativity and events
- Design and production
- Event philosophy and psychology
- Event experiences
- MICE
- Impacts and legacies (Beyond the Waves)

Programme

Tuesday, December 12, 2017

- 16:00 Bus departs from Rosen Shingle Creek Hotel to Orange County Convention Center (OCCC) and to Amway Center
- 16:30-18:30 Visit to Orange County Convention Center (OCCC) and Technology Presentation
- 17:00-18:00 Visit to Amway Center
- 18:00-19:00 Travel to Topgolf Orlando from Amway Center and pick up delegation at OCCC
- 18:45 Bus departs from Rosen Shingle Creek Hotel to Topgolf
- 19:00-21:00 Welcome Reception at Topgolf Orlando
- 21:00 Bus back to Rosen Shingle Creek Hotel

Wednesday, December 13, 2017

- 08:00-13:00 Registration open at Rosen College of Hospitality Management
- 08:15-08:45 Bus depart from Rosen Shingle Creek Hotel to Rosen College of Hospitality Management
- 09:00-09:30 Official opening by conference chairs and introduction to the Tourism, Events and Attraction (TEA) Department of Rosen College (Robertico Croes, Associate Dean and Sevil Sonmez, Chair of TEA Department, Rosen College of Hospitality Management, University of Central Florida (USA) – **(Room 111)**)
- 09:30-10:00 **Introductory Keynote:** How to go beyond the waves: Moving from hedonic to utilitarian events - Dean Abraham Pizam, Dean, Rosen College of Hospitality Management, University of Central Florida (USA) - **(Room 111)**
- 10:00-10:30 **Keynote:** The evolution of festivals & events in a changing world - Steven Wood Schmader, President and CEO, International Festival and Events Association (USA) - **(Room 111)**
- 10:30-11:15 **Research and Grants Panel- (Room 111)** **Moderator: Sevil Sonmez**
- Robertico Croes – Rosen College of Hospitality Management, University of Central Florida (USA)
 - Leonardo (Don) Dioko – Institute for Tourism Studies (Macau)
 - Rhodri Thomas – Leeds Beckett University (UK)
 - Karin Weber – Hong Kong Polytechnic University (Hong Kong)
- 11:15-11:45 Tea/Coffee Break (Disney Dining Room/Courtyard)

11:45-12:15 **Keynote:** Introduction to OCCC, what is happening in the MICE Industry? The importance of working with educational institutions – Kathie Canning: Executive Director, Orange County Convention Center (USA) - **(Room 111)**

12:15-13:00 **Industry Panel - (Room 111)** **Moderator: Robertico Croes**

- Suzanne Neve – CEO, Florida Festivals & Events Association (FFEA) (USA)
- Jason Siegel – CEO, Central Florida Sports Commission (USA)
- Adrienne Six – Director of Event Sales, Topgolf Orlando (USA)
- Kirk Wingerson – Marketing Division Manager, City of Orlando (USA)

13:00-14:00 Lunch (Disney Dining Room) and announcement of the Best Paper Award

14:00-15:25 **Parallel Sessions:** Presentations (20 min presentation, 5 min questions, 5 change)

	Cultural Festivals and Education Session Chair: Leonardo (Don) Dioko	Impacts of Events and Festivals Session Chair: Robertico Croes	MICE Session Chair: Julie Whitfield
Rooms	Room 205	Room 207	Room 209
14:00-14:25	Developing leaders for a collaborative workforce: The challenge for event management training in higher education L Baker-Malungu* Institute for Tourism Studies, Macao	The economic benefits of Caribbean Carnival: The case of Curacao D. Daal*, C. Campagnard, M. Rivera Curacao Tourist Board, Curacao Tourist Board, Curacao, University of Central Florida, USA	Toward unsupervised machine learning technique to discover the key topics influence exhibition visitor engagement in social media: A case study from Taiwan C.L. Huh * Fu-Jen Catholic University, Taiwan
14:30-14:55	Authenticity and cultural sustainability at the Osun Osogbo Festival, Nigeria K.D. Aleshinloye *, K.M. Woosnam, M.A. Ribeiro, J. Jiang University of Central Florida, University of Georgia, USA, University of Surrey, UK, Frostburg State University, USA	Is higher attendance, the better? Examining the impacts of meeting size on attendees' psychological responses and consequence behavior T. Lu*, W, Wei, L. Wu, J. Swanson, D. Getz University of Kentucky, USA, University of Central Florida, USA, Temple University, USA, University of Kentucky, USA, University of Calgary, Canada	How do planners and attendees experience a convention in real time? M. Beardsley*, M. Uysal Virginia Tech University, USA
15:00-15:25	Carnival event experience in Brazil L Marques*, C. Borba Universidade Aberta, Portugal, Universidade Federal de Pernambuco, Brazil	Spending behavior and music interest in SIDS: The case of the Aruba Summer Music Festival R. Croes, M. Rivera, K. Semrad, M. Kelly* University of Central Florida, USA, University of Central Florida, USA, University of Central Florida, USA, Aruba Tourism Authority, Aruba	The role of social influence on expo attendee behavior utilizing video tracking E. Olson* Iowa State University, USA

- 15:30-16:00 Tea/Coffee Break (Disney Dining Room/Courtyard) (Poster Session)
- 16:00-16:30 **Keynote:** Making sense of our business engagement: illusions, aspirations and achievements – Professor Rhodri Thomas, Dean, School of Events, Tourism & Hospitality Management, Leeds Beckett University (UK) - **(Room 111)**
- 16:30-17:00 Summary, reflection and questions of day one of the conference - **(Room 111)**
- 17:15-17:30 Bus depart from Rosen College to Rosen Shingle Creek Hotel
- 18:00 Bus depart from Rosen Shingle Creek Hotel to Disney Springs for night on the town
- 18:30-20:30 Dinner – Planet Hollywood at Disney Springs
- 21:00-22:30 Entertainment – Cirque du Soleil “La Nouba” show at Disney Springs
- 23:00 Bus depart from Disney Springs to Rosen Shingle Creek Hotel

Thursday, December 14, 2017

- 08:00-12:00 Registration open at Rosen College of Hospitality Management
- 08:15-08:45 Bus depart from Rosen Shingle Creek Hotel to Rosen College
- 09:00-09:30 **Keynote:** Designing the event management curriculum for the future - Donald Getz, University of Calgary (Canada) - **(Room 111)**
- 09:30-10:15 **Curriculum Panel - (Room 111)** **Moderator: Donald Getz**
- Deborah Breiter Terry – Rosen College of Hospitality Management, University of Central Florida (USA)
 - Ubaldino (Dino) Couto – Institute for Tourism Studies (Macau)
 - Caroline Jackson – Bournemouth University (UK)
 - Kelly Semrad – Rosen College of Hospitality Management, University of Central Florida (USA)
- 10:15-10:45 Tea/Coffee Break (Disney Dining Room/Courtyard)
- 10:45-11:15 **Keynote:** Taking events and festival journals to SSCI status - Fevzi Okumus, CFHLA Preeminent Chair Professor, Rosen College of Hospitality Management, University of Central Florida (USA) **(Room 111)**
- 11:15-12:00 **Editors Panel - (Room 111)** **Moderator: Mathilda van Niekerk**
- Alan Fyall – Rosen College of Hospitality Management, University of Central Florida (USA): Journal of Destination Marketing and Management

- Judith Mair – University of Queensland (Australia): International Journal of Event and Festival Management
- Fevzi Okumus – Rosen College of Hospitality Management, University of Central Florida (USA): International Journal of Contemporary Hospitality Management (IJCHM), Journal of Hospitality and Tourism Insights (JHTI)
- Rhodri Thomas – Leeds Beckett University (UK): Journal of Policy Research in Tourism, Leisure & Events

12:15-14:10 **Parallel Sessions:** Presentations (20 min presentation, 5 min questions, 5 change)

	Events <i>Session Chair: Karin Weber</i>	Event and Festival Planning <i>Session Chair: Rhodri Thomas</i>	Motivation and Satisfaction <i>Session Chair: Alan Fyall</i>
Rooms	Room 205	Room 207	Room 209
12:15-12:40	Fostering community support for mega events: A narrative inquiry of social impacts experienced as a result of hosting the FIFA 2010 World Cup in Cape Town, South Africa R. Musikavanhu* <i>Bournemouth University, UK</i>	Festival sustainability: A long-term holistic perspective J. Mair* <i>The University of Queensland, Australia</i>	Festival image: Relationships between the dimensions of satisfaction, image, and sources of information of the Brazilian Beer Festival S.J.G. dos Anjos*, F.D. Zucco, C.B. Kraus, T.D. Santos <i>Universidade do Vale do Itajaí – UNIVALI, Universidade do Vale do Itajaí – UNIVALI, Universidade do Vale do Itajaí – UNIVALI, Universidade Regional de Blumenau – FURB, Brazil</i>
12:45-13:10	A longitudinal study of the long-term events impacts for Weymouth UK from hosting events for London 2012 D. Sadd* <i>Bournemouth University, UK</i>	Threats to safeguarding cultural festivals in Macao U. Couto*, P.K.L. Chan <i>Institute for Tourism Studies, Macao</i>	A study of the emotions experienced by attendees and non-attendees: Evidence from the Tour de France D. May*, G. Berridge, E. Kitchen, G. Sullivan <i>Sheffield Hallam University, University of Surrey, Leeds Beckett University, Coventry University, UK</i>
13:15-13:40	A Bourdieusian critique of event professionalisation C. Jackson* <i>Bournemouth University, UK</i>	Participating and non-participating residents' perceptions and attitudes towards Macao's Drunken Dragon Festival S. Choi*, U. Couto, S.S. Imon <i>Institute for Tourism Studies, Macao</i>	Important contemporary motivators and inhibitors in association delegates' conference attendance choice J. Cassar, A. Chapman, J. Whitfield* <i>Bournemouth University, UK</i>
13:45-14:10	"This Blows!" – The impact of extreme weather on sporting events: The case of the Cape Town Cycle Tour J. Giddy* <i>University of Johannesburg, South Africa</i>	The power of EWOM for music festivals in the experience economy K. Semrad*, R. Croes, M. Rivera <i>University of Central Florida, USA</i>	Research on the destination tourist trust and its influence on tourism image J. Liu, Z. Wang, S. Fang, S. Li* <i>Anhui Normal University, China Anhui Normal University, China Xiangtan University, China Anhui Normal University, China</i>

14:15-15:15 Lunch (Disney Dining Room/Courtyard)

15:15-17:40 **Parallel Sessions:** Presentations (20 min presentation, 5 min questions, 5 change)

	Mega Events & Music Festivals <i>Session Chair: Ubaldino (Dino) Couto</i>	Event and Festival Design <i>Session Chair: Judith Mair</i>	MICE <i>Session Chair: Caroline Jackson</i>
Rooms	Room 205	Room 207	Room 209
15:15-15:40	Hosting the summer Olympics and its effect on income inequality: A preliminary assessment L. Dioko* <i>Institute for Tourism Studies, Macao</i>	The future of festival design in an emerging happiness economy V. Biaett* <i>Nido R. Qubein School of Communication High Point University, USA</i>	The role of an official website for international convention centres in e-marketing era X. Tan*, D. Wu <i>Institute for Tourism Studies, Macao</i>
15:45-16:10	Do mega events cause change in county or destination image? The case of 2016 Olympic Games in Brazil A. Tasci, J. Hahm*, D. Breiter Terry <i>University of Central Florida, USA</i>	Scale development to measure the co-creation experience, and resulting value in art exhibitions E. Mathis*, M. van Niekerk, F. Okumus, M. Rivera <i>University of Central Florida, USA</i>	Efficient use of data resources using the example of meetings and events industry management in Poland K. Celuch*, E. Dziedzic <i>Warsaw School of Tourism and Hospitality Management, Warsaw School of Economics, Poland</i>
16:15-16:40	Experience and spending behavior in SIDS: The case of the Aruba Soul Beach Music Festival R. Croes*, M. Rivera, K. Semrad, V. Shapoval <i>University of Central Florida, USA</i>	The gestalt of event creativity? C. Jackson* J. Morgan, C. Laws <i>Bournemouth University, UK</i> <i>University of Westminster, UK</i> <i>University of Westminster, UK</i>	Overwhelming or exciting: An action study of conference attendee experience J. Wiitala*, J. Hahm, D. Breiter Terry <i>University of Central Florida, USA</i>
16:45-17:10	The eclectic economics of music festivals occurring in small island destinations K. Semrad*, R. Croes, M. Rivera <i>University of Central Florida, USA</i>	The “ale” in female: The feminine voice at a craft beer fermentation fest W. Coetzee*, C Lee <i>University of Otago, New Zealand</i>	Support for green conferences only lip service—so what can be done? K. Bock, L. Dioko, J. Whitfield* <i>Institute for Tourism Studies, Macao</i> <i>Bournemouth University, UK</i>
17:15-17:40	Holiday effects on the stock price of the amusement park and attractions industry in the United States C. Chiu* <i>National Ilan University, Taiwan</i>	Corporate social responsibility and its impact on employee organizational identification and organizational commitment: A perspective of Chinese brand hotel employees S. Li*, Z. Wang, M. Wang, J. Liu <i>Anhui Normal University, China</i>	How to secure funding for a convention center and CVBs: The cases of the State of Florida and Japan T. Hara, K. Fakuda* <i>University of Central Florida, USA</i>

17:45-19:00 Closing Reception in the Rosen College Courtyard

18:00-19:15 Bus depart from Rosen College to Rosen Shingle Creek Hotel

Introductory keynote – How to go beyond the waves: Moving from hedonic to utilitarian events

Abraham Pizam



*Dean, Rosen College of Hospitality Management,
University of Central Florida*

Dr. Abraham Pizam is Dean and Linda Chapin Eminent Scholar Chair in Tourism Management in the Rosen College of Hospitality Management, at the University of Central Florida, Orlando, Florida, U.S.A. Professor Pizam is widely known in the field of Hospitality and Tourism Management and has conducted research projects, lectured, and served as a consultant in more than 30 countries. He has held various academic positions, in the U.S.A, U.K., France, Austria, Australia, New-Zealand, Singapore, Israel and Switzerland, has authored more than 160 scientific publications and ten books, is the Editor-in-Chief of the International Journal of Hospitality Management and serves on the editorial boards of 20 academic journals. Professor Pizam has conducted consulting and research projects for a variety of international, national and regional tourism organizations.

Keynote – The evolution of festivals & events in a changing world

Steven Wood Schmader, CFEE



President and CEO, International Festivals & Events Association (IFEA World)

Steven Wood Schmader, CFEE, is the President & CEO of the International Festivals & Events Association (IFEA World), which celebrates 62 years as the “Premiere Association Supporting and Enabling Festival & Event Professionals Worldwide” in 2017. The IFEA operates with a vision of a globally united industry that touches lives in a positive way through celebration and is the presenting body of the IFEA World Festival & Event City Award, which recognizes those global markets that provide and leverage the most positive partnerships between events and the cities that host them. Schmader also serves as the publisher and editor of “ie: the business of international events” and the Founding Director of the IFEA’s Event Management School at the Oglebay National Training Center in West Virginia. Schmader’s 40-year professional career includes the creation, management and production of large citywide festivals, sporting events, government events, parades, airshows and Millennium celebrations. In his role with the IFEA he works in partnership with global event professionals and organizations, government entities, sponsors, tourism agencies, media and academic institutions, to raise the bar and brand of our common industry, today and into the future. Schmader is an author and highly-rated speaker on industry issues and trends.

Keynote – Introduction to OCCC, what is happening in the MICE Industry? The importance of working with educational institutions

Kathleen Canning



Executive Director, Orange County Convention Center (OCCC)

Kathleen “Kathie” Canning joined the Orange County Convention Center (OCCC) in 1985. Kathie provides invaluable assistance in the sales, service planning and development for the Center’s three expansion projects. In December 2002, Kathie was promoted to the position of Deputy General Manager. In this role, she assists in the operation and management of the Convention Center. In 2012, Orange County Mayor Teresa Jacobs appointed Kathie to the executive director position. Canning will continue to direct and supervise all aspects of finance, marketing and operations of the facility. Kathie is an active member of the Professional Convention Management Association (PCMA), the International Association of Exhibitions and Events (IAEE), the International Association of Assembly Managers (IAAM) and Meeting Planners International (MPI). During her career, Kathie has devoted her time to many not-for-profit organizations including The United Way Leadership Club, Orlando Chamber of Commerce and the Orlando Convention and Visitors Bureau. Kathie graduated from York College in New York City with a bachelor’s degree in Education, and received her master’s degree from Adelphi University. In addition to her work at the OCCC, Kathie is an adjunct instructor at the University of Central Florida’s Rosen School of Hospitality Management in Orlando, Florida.

Keynote – Making sense of our business engagement: illusions, aspirations and achievements

Rhodri Thomas



Professor, Tourism and Events Policy, Dean, School of Events, Tourism, and Hospitality Management, Leeds Beckett University, UK

Rhodri Thomas is Professor of Tourism and Events Policy and Dean of the School of Events, Tourism and Hospitality Management at Leeds Beckett University, UK. Originally trained as an economist, he now engages in inter-disciplinary policy-related research in the context of the tourism, hospitality and events sectors. Rhodri has acted as a 'specialist expert' on policy issues for the OECD, the European Commission and for government departments and other agencies in the UK and elsewhere. He has completed several Economic and Social Research Council (ESRC) grant and non-grant funded projects and is a member of their Peer Review College. His Chair was supported by the Institute of Travel and Tourism (ITT) for five years. Rhodri is the Editor-in-Chief of the Journal of Policy Research in Tourism, Leisure and Events, a Coordinating Editor for the International Journal of Hospitality Management and an Academic Editor for Sustainability. He sits on the Editorial Boards of several leading journals including Tourism Management and the International Journal of Contemporary Hospitality Management.

Keynote – Designing the event management curriculum for the future

Donald Getz



Professor Emeritus of Tourism, Haskayne School of Business, University of Calgary

Don Getz is a professor in the Tourism and Hospitality Management program at the Haskayne School of Business. He holds a BES from the University of Waterloo, an MA from Carlton University, and a PhD from the University of Edinburgh. Before joining the University of Calgary, Dr. Getz began his teaching career as an assistant professor at the University of Waterloo in the Department of Recreation and Leisure Studies. Don is an ongoing visiting professor of Events Management at Griffith University in Australia, and an ongoing visiting professor at Sheffield- Hallam University in England. Dr. Getz teaches international tourism, planning and policymaking, resort management and event management. His ongoing research involves special-interest tourism (i.e. wine) and event-related issues such as management, event tourism, and events and culture. The research that Dr. Getz conducts often has a particular focus on the effects or impacts of tourism and recreation on people, the environment, and the economy.

Keynote – Taking events and festival journals to SSCI status

Fevzi Okumus



CFHLA Preeminent Chair Professor, Rosen College of Hospitality Management, University of Central Florida

Dr. Fevzi Okumus is the CFHLA Preeminent Chair Professor within the Hospitality Services Department at the University of Central Florida's Rosen College of Hospitality Management. He joined the Rosen College in 2005. He was the founding Chair of the Hospitality Services Department from 2007-2013. He received his PhD in Strategic Hotel Management from Oxford Brookes University, UK. He has a Master of Science degree in International Hotel Management from Oxford Brookes University, UK and a Bachelor of Science degree in hospitality and tourism from Cukurova University, Turkey. He worked in the hotel industry in various functional areas and roles before becoming an educator. Dr. Okumus' teaching and consultancy areas include hotel/lodging management, strategic management, leadership development, international hospitality management and introduction to hospitality and tourism. His research areas include competitive advantage, sustainability and green practices, strategy implementation, knowledge management, hotel/lodging management, crisis management, destination marketing, information technology and developing countries. He has over 230 academic publications (over 100 refereed journal articles, three books, 12 book chapters and 85 conference presentations and reports). According to GoogleScholar, as of October 2017, his publications have received over 4347 citations and he has an h-index of 33. He chaired/co-chaired and served on numerous PhD dissertation and master thesis committees. He secured competitive grants, contracts and scholarships totaling an amount of \$500,000. He is the Editor-in-Chief of the *International Journal of Contemporary Hospitality Management (IJCHM)*, which has an Impact Factor of 3.196 and is considered one of the top hospitality and tourism journal in the field. He is also the Co-Founding Editor of the *Journal of Hospitality and Tourism Insights*. He serves on the editorial boards of 24 international journals. He is a frequent speaker at international conferences. He is a Visiting Professor at San Yet Sen University's Business School in Guangzhou, China. Dr. Okumus has received numerous awards and recognitions including "The Michael D. Olsen Research Award" in 2016; "The University of Central Florida Scroll & Quill Society Award" in 2017 and the "CFHLA Preeminent Chair Professor" again in 2017.

Research and Grants Panel



Robertico Croes

*Professor
Associate Dean, Administration & Finance
Rosen College of Hospitality Management
University of Central Florida, USA*



Leonardo A. N. Dioko

*Professor
Director of IFT Tourism Research Center
Institute for Tourism Studies, Macao*



Rhodri Thomas

*Professor, Tourism and Events Policy
Dean, School of Events, Tourism, and Hospitality
Management
Leeds Beckett University, UK*



Karin Weber

*Associate Professor
School of Hotel and Tourism Management
The Hong Kong Polytechnic University, Hong Kong*

Industry Panel



Suzanne Neve

*CEO
Florida Festivals & Events Association*



Jason Siegel

*CEO
Central Florida Sports Commission*



Adrienne Six

*Director of Event Sales
Topgolf Orlando*



Kirk Wingerson

*Marketing Division Manager
City of Orlando*

Curriculum Panel



Deborah Breiter Terry

*Rosen College of Hospitality Management
University of Central Florida, USA*



Ubaldino Couto

Institute for Tourism Studies, Macao



Caroline Jackson

Bournemouth University, UK



Kelly Semrad

*Rosen College of Hospitality Management
University of Central Florida, USA*

Editors Panel



Alan Fyall

*Rosen College of Hospitality Management
University of Central Florida, USA*

Journal of Destination Marketing and Management



Judith Mair

University of Queensland, Australia

*International Journal of Event and Festival
Management*



Fevzi Okumus

*Rosen College of Hospitality Management
University of Central Florida, USA*

*International Journal of Contemporary Hospitality
Management*

Journal of Hospitality and Tourism Insights



Rhodri Thomas

*School of Events, Tourism, and Hospitality
Management, Leeds Beckett University, UK*

Journal of Policy Research in Tourism, Leisure & Events

Abstracts and Extended Abstracts

AUTHENTICITY AND CULTURAL SUSTAINABILITY AT THE OSUN OSOGBO FESTIVAL, NIGERIA

KAYODE D. ALESHINLOYE

University of Central Florida, USA

KYLE M. WOOSNAM

University of Georgia, USA

MANUEL A. RIBEIRO

University of Surrey, UK

JINGXIAN JIANG

Frostburg State University, USA

PURPOSE

Many communities in most parts of the world have increased efforts in promoting and sustaining their cultural identities through the creation of cultural festivals, as both national and international tourist markets continue to grow. Festivals are used to celebrate community values, ideologies, identities and overall community fabric (Getz, Andersson, & Carlsen, 2010). Such events provide ample opportunities for residents to showcase their rich intangible heritage, local traditions, ethnic backgrounds and cultural landscapes for tourists to experience an authentic cultural atmosphere and provide opportunities for interacting with local residents (McKercher, Mei, & Tse, 2006). Nowadays, due to the dynamic and highly competitive nature of tourism markets, destinations are continually improving their offerings to gain modest advantages in the jostle of tourists seeking authentic experiences. As such, cultural festivals are one of the complimentary activities planners and managers use to broaden the scope of tourist appeal within many emerging destinations (Herrero, Sanz, Bedate, & del Barrio, 2012).

Tourists' quest for authentic experiences and residents' desire to produce them has led to a complicated power play within destinations regarding what is authentic or not. In a cultural festival setting, the narratives are very important not only to the tourists whose primary mission is to witness the event unadulterated but also the residents who are aware and want to maintain their values and traditions. The power play among stakeholders arises when the cultural festival is being extended and marketed to an international community where some of narratives will be won and lost, as in the case of the Osun Osogbo festival being a UNESCO world heritage site (WHS). The ancient Osun Grove, where the annual Osun Osogbo Festival is held, gained WHS designation in 2005 at the UNESCO Convention in Durban, South Africa, which made it the second such WHS in Nigeria. Undoubtedly, the designation has aroused international interest in the traditional event, evident with the presence of diverse international guests. Most especially, diasporic Africans living in the United States and Caribbean countries utilize the festival to reaffirm their identities through spiritual and religious development (Murphy & Sanford, 2001).

The purpose of this present study is two-fold: 1) to investigate the impacts of authenticity from the political and cultural perspective in the pre- and post-designation of the Osun Cultural Festival by UNESCO in assessing the long-term sustainability of the festival's traditionpractice

and customs and to 2) examine the conflicts, tensions, and struggles among key stakeholders (e.g., government, Osun traditionalists/cultural custodians, residents, tourism agencies, and the sponsors) in the planning, organization, and evaluation of the annual festival.

DESIGN/ METHODOLOGY/APPROACH

Data for this study were collected in the ancient city of Osogbo, State of Osun, Nigeria in August, 2014 during the annual celebration of the Osun Osogbo Festival. The target populations for this study were residents of Osogbo, tourists to the annual Osun Osogbo Cultural Festival (OOCF), and stakeholders directly involved with the planning, implementation, and evaluation of the festival. Data were collected using both qualitative and quantitative research methodologies. For the qualitative portion of the study, some key stakeholders were identified within the community for an in-depth face-to-face interview concerning their views and perspectives about the festival. The interviews were recorded, transcribed, and analyzed in efforts to identify major emergent themes. In the analysis, the raw data was reduced and grouped into the meaningful patterns or themes using content analysis before drawing conclusions and verification. Residents and tourists were asked a series of open-ended questions within a survey instrument. As such, the qualitative data can be considered embedded within a more quantitative survey; also known as an “embedded mixed research” design (Creswell, 2013).

Quantitative data were collected from two samples using different sampling strategies. For residents, a cluster sampling strategy was used while for tourists, a systematic random sampling strategy was utilized. Of the 628 residents contacted, 147 declined to accept the questionnaire (76.6% survey acceptance rate). Of the 481 distributed, 470 questionnaires were completed by residents (97.7% survey completion rate). The overall response rate for Osogbo residents was 74.8%. Among the tourists, a total of 665 were intercepted, with 175 declining to participate (73.2% survey acceptance rate). Of the 480 distributed, 461 questionnaires were completed by tourists (96.0% survey completion rate). The overall response rate among tourists was 70.4%.

FINDINGS

Sample descriptives for residents and tourists (i.e., gender, age, marital status, education, and attendance) are presented below in Table 1. Findings from the study indicated that Osogbo residents and tourists to the Grove and the Osun Osogbo Festival see each as a protected sacred place for cultural significance, creative arts, and as a unique symbol for the Yoruba people and blacks in diaspora. More importantly, both consider the UNESCO world heritage site designation as a valuable asset in the promotion, popularity and global appeal of the cultural festival. Additionally, 53.6% of the visitors agreed that the WHS designation influenced their decision to visit the festival.

A majority of the Osogbo residents (57.8%) however indicated that the WHS designation had no impact on them personally while also stressing that their opinions were not considered in the process of Osun becoming a WHS.

Overall, mixed perceptions among residents exist regarding the events occurring at the Sacred Grove and during the Festival. While some sees it as means to preserving the culture and tradition of the black race, others view it as an act of idol worshipping which, as they claim, should not be encouraged.

Table 1
DESCRIPTIVE SUMMARY OF PARTICIPANTS

Variable	Residents (%)	Tourists (%)
Gender ($n_{residents} = 470$; $n_{tourists} = 461$)		
Female	50.9	46.2
Male	49.1	53.8
Age ($n_{residents} = 470$, $M_{residents} = 30.6$ years; $n_{tourists} = 461$, $M_{tourists} = 32.9$ years)		
18-29	58.3	45.7
30-39	21.5	28.5
40-49	12.1	16.1
50-59	4.7	6.7
≥ 60	3.4	3.0
Marital status ($n_{residents} = 470$; $n_{tourists} = 460$)		
Single	54.9	43.6
Married	41.1	51.2
Divorced	2.1	3.0
Widowed	1.5	2.0
Others	0.4	0.2
Education ($n_{residents} = 470$; $n_{tourists} = 461$)		
Primary/ elementary school	5.1	1.3
Secondary/high school certificate/ diploma	36.8	27.5
Technical, vocational or trade school	10.9	20.4
Four-year college	34.9	40.6
Master's degree	9.8	8.9
Ph.D./M.D./professional	2.6	1.3
First time to OOF ($n_{residents} = 463$; $n_{tourists} = 461$)		
No ($M_{number\ of\ previous\ times\ (residents)} = 8.3$; $M_{number\ of\ previous\ times\ (tourists)} = 7.6$)	61.7	62.5
Yes	36.8	37.5

In addressing the main purpose of the study, findings indicated that though the locals appreciate the government effort in the funding and promotion of the festival, they are also of the opinion that they have little control in decision making and their voice is not heard nor represented in planning. Residents' concern is premised on the fact that the event is being staged for the tourists' appeal, with the government focusing more on entertainment and cultural exposition, neglecting the religious/spiritual aspect. Since the UNESCO world heritage site designation in 2005, the state government (through the Ministry of Tourism), the federal agencies, and the major sponsors have asserted greater control in the planning, implementation, and evaluation of the annual festival with little to no contribution from the local residents.

RESEARCH LIMITATIONS/IMPLICATIONS

This study adopted a comprehensive approach in explaining the authenticity and cultural sustainability of the Osun festival using both quantitative and qualitative methodologies (Kim & Jamal, 2007) but the research team was limited by time constraints, lack of available key stakeholders with whom to speak, and other sundry issues in interviewing a much larger set of people. Unfortunately, the timing of the festival also coincided with the outbreak of the Ebola virus in 2014, greatly impacting many international tourists' from participating in the events during the two-week festival.

PRACTICAL IMPLICATIONS

Understandably, due to poor financial resources, the festival organizers in most developing countries rely solely on the government and sponsors for funding the events (Lentz, 2001), but in doing so, they are losing control of the originality and organization of the festival. The government markets the festival to the international community as means of displaying local culture and tradition, entertainment, and religion/spirituality but the locals believe that the religious aspect, being the most important, has been relegated to the background. Festival managers should ensure that all the stakeholders are fully involved and their views held in high esteem in the planning, implementation, and evaluation of the festival (Muller & Pettersson, 2006).

ORIGINALITY/VALUE

This study marks the first time the issues of authenticity and cultural sustainability at the Osun Osogbo festival have been addressed providing the foundation in which subsequent work using other theoretical models should be utilized.

REFERENCES

- Creswell, J. W. (2013). *Research design: Qualitative, quantitative, and mixed methods approaches*. Sage publications.
- Getz, D., Andersson, T., & Carlsen, J. (2010). Festival management studies: Developing a framework and priorities for comparative and cross-cultural research. *International Journal of Event and Festival Management* 1(1), 29-59.
- Herrero, L. C., Sanz, J. Á., Bedate, A. & del Barrio, M. J. (2012). Who Pays More for a Cultural Festival, Tourists or Locals? A Certainty Analysis of a Contingent Valuation Application. *International Journal of Tourism Research* 14(5), 495-512.
- Kim, H., & Jamal, T. (2007). Touristic quest for existential authenticity. *Annals of Tourism Research*, 34(1), 181-201.
- Lentz, C. (2001). Local Culture in the National Arena: The Politics of Cultural Festivals in Ghana. *African Studies Review*, 44(3), 47-72
- Mckercher B., Mei, W. S., & Tse, S.M. (2006). Are short duration cultural festivals tourist attractions? *Journal of Sustainable Tourism* 14(1), 55-66.
- Murphy, J.M., & Sanford, M. (2001). *Osun across the waters: A Yoruba goddess in Africa and the Americas*. Indiana University Press.
- Müller, D. K., & Pettersson, R. (2006). Sámi heritage at the winter festival in Jokkmokk, Sweden. *Scandinavian Journal of Hospitality and Tourism*, 6(1), 54-69.

FESTIVAL IMAGE: RELATIONSHIPS BETWEEN THE DIMENSIONS OF SATISFACTION, IMAGE, AND SOURCES OF INFORMATION OF THE BRAZILIAN BEER FESTIVAL

SARA JOANA GADOTTI DOS ANJOS
Universidade do Vale do Itajai, Brazil

FABRICIA DURIEUX ZUCCO
Universidade do Vale do Itajai, Brazil

CAMILA BELLI KRAUS
Universidade do Vale do Itajai, Brazil

THIAGO DOS SANTOS
Universidade Regional de Blumenau, Brazil

PURPOSE

To analyze the image of the Beer Brazilian Festival and the correlation between the variables.

DESIGN/ METHODOLOGY/APPROACH

We analyze in two different periods the correlations between satisfaction, image of the event, and sources of information of the Brazilian Beer Festival, that took place in Blumenau, Santa Catarina (Brazil), from the perception of people who attended this event in 2013 and 2017.

This is a quantitative research using a survey method. The data collection instrument was a self-administered, structured questionnaire, based on the theoretical-methodological approach of Deng, Li & Shen (2013) and Xiang & Gretzel (2010).

The study population consists of people who attended the Brazilian Beer Festival, distributed over eight days of the event (four days in 2013 and four in 2017), totaling 67,734 people. We used non-probability convenience sampling to select 507 respondents in 2013 and 508 respondents in 2017, totaling 1,016 individuals.

The analyses were performed using the mean and standard deviation (descriptive statistics), factor analysis and structural equation modeling (multivariate statistics).

FINDINGS

Prior to factor analysis we applied the Kaiser-Meyer-Olkin (KMO) measure of sampling adequacy and the Bartlett's Test of Sphericity (BTS) to verify the suitability of data for factor analysis. KMO value is 0.92. According to Hair Jr. et al. (2005) values higher than 0.70 are acceptable. The BTS value is 6889.155. Both values indicate the suitability of data for factor analysis.

We conducted exploratory factor analysis through principal components with standard varimax rotation. In this article we adopt the following criteria: factor extraction with eigenvalues greater than 1 and communalities greater than 0.50

In this way, we present factor analysis (Table 1) in which all statements have values greater than the criteria established by Hair Jr. et. al. (2005), since the communalities are greater than 0.50. We excluded the variables Q4, Q12 and Q21 (highlighted in red) from the construct since the values of factors are less than 0.50.

Table 1
FACTOR ANALYSIS OF CONSTRUCT IMAGE OF THE EVENT (2013+2017)

Variables	Factor 1	Factor 2	Factor 3
Q1 – The visit to the Festival satisfied my curiosity.	0.36	0.154	0.596
Q2 – The Beer Festival has good security.	0.248	0.268	0.549
Q3 – The staff of the Beer Festival is well prepared.	0.389	0.15	0.566
Q4 – The venue has good and clean restrooms.	0.277	0.334	0.453
Q5 – The visit has broadened my horizons, giving me the opportunity to experience different cultures.	0.634	0.063	0.338
Q6 – The shows at the Festival are appealing and interesting.	0.587	0.222	0.123
Q7 – Beer drinking spots are good and adequate.	0.565	0.125	0.492
Q8 – The variety of beer is appealing.	0.192	0.137	0.69
Q9 – Rest areas at the Festival are sufficient.	0.152	0.751	0.024
Q10 – It is easy to buy tickets and enter the Festival.	0.046	0.561	0.33
Q11 – The Festival is equipped with a good air conditioning system.	0.056	0.758	0.104
Q12 – The promotion of the Beer Festival is effective and wide-reaching.	0.232	0.369	0.265
Q13 - The variety of beer is not appealing.	0.32	0.031	0.531
Q14 – I learn about new cultures by attending the Beer Festival.	0.714	0.094	0.103
Q15 – The services provided at the Festival are high-quality.	0.57	0.308	0.353
Q16 – The space at the venue is adequate for the number of visitors.	0.248	0.676	0.197
Q17 – The concept of the Beer Festival is unique and innovative.	0.672	0.262	0.007
Q18 – Staff at the Beer Festival are friendly and helpful.	0.541	0.239	0.305
Q19 – The visit to the Festival brings me closer to my family and friends.	0.571	0.1	0.151
Q20 - The queues at the ticket booths are organized.	0.38	0.569	0.147
Q21 – The theme of the Festival fits the city of Blumenau.	0.335	0.334	0.407

Extraction method: Principal component analysis.

Rotation method: Varimax with Kaiser normalization.

Rotation converged in 5 iterations

From the rotation matrix and significance of variables within the factors of the construct we renamed the new sets. The first indicates the attractions of the event, culture, shows, and services provided at the festival. The second factor, includes 5 variables related to the infrastructure of the festival. The third factor is composed of 6 variables that represent the visitor experience.

Using structural equation modeling (SEM) we verified the relationship between the scales. This technique, according to Hair et al. (2005), combines factor analysis and linear regression for statistical verification of possible relationships between constructs.

Figure 1
MODELING (2013+2017)

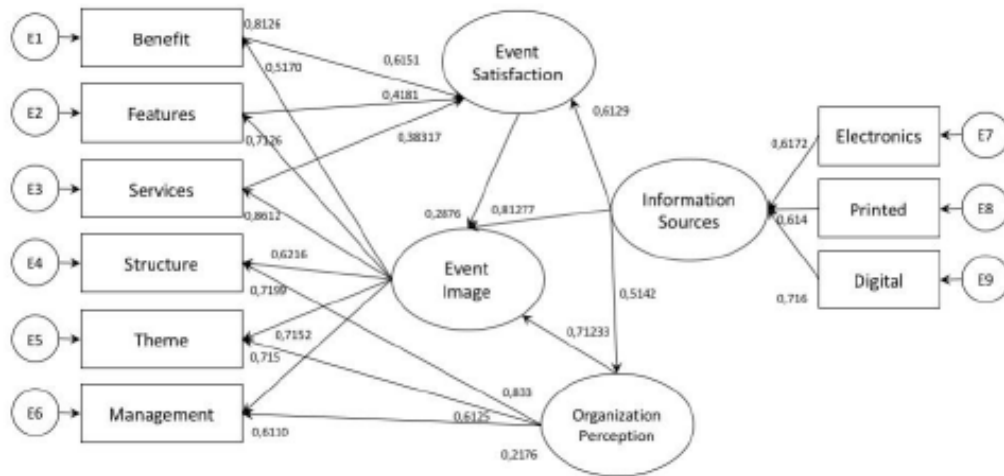

From the structural equation modeling (SEM) we verify that the Image of the Event (81%) is the best representation of sources of information. The Perception of the Organization has influence of 83% on Services provided at the event and Satisfaction with the event is best represented by the dimension of Benefits, with 61%.

We verify that Digital is the best representation of sources of information, with 71%, i.e. the internet, including all the portals and social media, has the greatest impact on the public regarding the dissemination of the event. Print media (newspaper, billboard, leaflets, etc.) represent 61%. Services (86%) represent best the scale of the Image of the Event. Following, we have Benefits (81%), Infrastructure (71%), Theme (71%), Convenience (71%), and Management (17%).

RESEARCH LIMITATIONS/ IMPLICATIONS

The results are a first approach to the research problem. Although the study refers to a particular socio-economic, geographic, and cultural context, we believe that the results - as research hypotheses - may be applicable to other markets with similar characteristics, since the analyzed variables can be applied in different contexts.

PRATICAL IMPLICATIONS

This study provides a practical contribution to festival image given that it relates the attributes of the image to the sources of information and behavior of the public. In this sense, the knowledge of the regional situation and possible implications for the development of local tourism and the positioning of the Brazilian Beer Festival as a tourism product.

ORIGINALITY/ VALUE

The study provides valuable information regarding new combinations of theoretical analysis factors for festivals image. This work presents a methodological combination of the assessment of the image of a festival by analyzing two editions of the event with an interval of 4 years.

REFERENCES

Deng, C. Q., Li, M., & Shen, H. (2013). Developing a Measurement Scale for Event Image. *Journal of Hospitality & Tourism Research*, 39(2), 245–270.

Hair Jr., J. F., Black, W. C., Anderson, R. E., & Tatham, R. L. (2005). *Análise multivariada de dados*. Bookman. Porto Alegre: Bookman.

Xiang, Zheng & Gretzel, Ulrike. (2010). Role of social media in online travel information search. *Tourism Management*, 31(2), 179-188.

HOW DO PLANNERS AND ATTENDEES EXPERIENCE A CONVENTION IN REAL TIME?

MEGHAN BEARDSLEY

Virginia Tech University, USA

MUZZO UYSAL

Virginia Tech University, USA

PURPOSE

Events are temporary ecosystems reflecting the world. A large segment of this industry is meetings (e.g. conventions, conferences, tradeshows, exhibitions, congresses). Meetings contributed over \$115 billion to US GDP in 2014 (CIC, 2014), and are economic drivers and contributors to the host community's multiplier effect. Conventions are a meeting type that are multi-faceted (e.g. educational sessions, social functions), potentially large-scale, and is this study's context. The anticipated issues for meetings are being able to engage individuals in a multidimensional space and designing targeted experiences (MPI, 2016). Getz (2008, 2016) declared that events literature has matured as a result of various disciplines (i.e. anthropology, sociology, economics), but there is a fundamental lack of theoretical development specifically within the field. Researchers seek to holistically understand the event experience.

Getz challenged the use of conceptualizing events because of the multiplicity of experiences possible at a specific event (Lunt, 2012). He endorsed the phenomenological approach for understanding this range. This allows for a holistic perspective of a phenomenon from the individual experiencing it, and is underutilized in events research. Ziakas and Boukas (2014) stated there is limited research on an event's experiential dimensions and meanings, and believe phenomenology is a sound philosophical framework for this. Understanding live, on-site experiences using phenomenology will provide insight. Previous research assessed individuals in post-experience phases, which may have been impacted by participant memory. This study's purpose is to understand a convention participant's on-site convention experience by employing a phenomenological approach.

LITERATURE REVIEW

Events transform a static environment into a meaningful experience (Page & Connell, 2014). Ryan (1997) sought to understand the meaning of experiences and apply it to a tourism context that was inclusive of special events. A few experience-centered theories have emerged. In psychology, Csikszentmihalyi (1990) touched on experience as an achievement of 'flow'. People seek intrinsically rewarding experiences leading to optimal arousal and flow that can lead to engagement, accomplishment, or transformation (Csikszentmihalyi, 1990). Pine and Gilmore (1998) introduced the 'experience economy', which involves four dimensions: absorption, immersion, and active/passive participation.

An event creates a liminoid zone separating itself from normal life (Ziakas & Boukas, 2014). Common factors of a liminoid zone include involvement, engagement, and reversion to normal life, sense of change, accomplishment, renewal, transformation, and relief/loss in order for an event to be special and memorable (Getz, 2012; Ziakas & Boukas, 2014). This complements Csikszentmihalyi's theory of flow.

People execute complementary processes to make sense of their world (Gergen, 1985). This sense-making process is called social constructionism, and has roots in symbolic interactionism. Symbolic interactionism is one of three primary approaches in sociology, and evaluates the multiple construction dimensions of social reality through an individual's autonomous activities (Rossman, 2003). Essentially, each individual at an event will leave with a different understanding based on how they socially constructed the experience. This study applies these two theories to defend the study's approach.

Proposed research questions:

1. How do convention participants interpret their on-site experience?
2. What roles do convention components (e.g. sessions, social functions) play in the overall experience?

METHODOLOGY

Phenomenology looks at participants' direct experiences and interpretations of the phenomenon, which in this case is a convention experience. Interpretive Phenomenological Analysis (IPA) and Experience Sampling Method (ESM) will be used. IPA is an in-depth analysis that connects personal accounts and subjective experience with symbolic interactionism (Smith & Eatough, 2007). ESM specializes in measuring experiences in real time via scheduled prompts. Using ESM addresses concerns regarding memory (Hektner, Schmidt, & Csikszentmihalyi, 2007).

Participants/Convention

A criterion purposive sampling method will be employed. The sample will consist of convention-specific planners/attendees. IRB protocol will be followed, and participants will be recruited via the convention's website.

Criteria for identifying convention:

1. Multi-day
2. Multi-faceted (e.g. concerts, breakouts, tradeshow, banquets)
3. Attendees from >50-miles away
4. Hosts >10,000 attendees
5. Social media component (e.g. Facebook, Instagram, Snapchat, Twitter, or app).

Examples of conventions: SxSW, IMEX, and Comic-Con.

Collection

Data will be collected via observation, semi-structured interviews, and diaries (via ESM pre-determined scheduled prompts). The researcher will collect observational notes to correlate. These prompts will be pilot tested by the researcher's peer to identify any issues like technical failure of the prompts, difficulty understanding prompts, or if the prompts are too frequent/infrequent.

Analysis

Data will be transcribed using NVivo and analyzed by:

1. Reading overall content
2. Developing codes/themes
3. Identifying similarities/differences
4. Constructing narrative

Researcher's Lens

The researcher has reflexivity due to employment and experience as planner/attendee.

Trustworthiness

Trustworthiness will be verified by: triangulation (multiple sources/data types), credibility (member checks), transferability (findings in rich, thick detail), dependability (audit trail of research design/analysis), and confirmability (external research auditor to assess practices) (DeCrop, 2004).

DISCUSSION, LIMITATIONS, & IMPLICATIONS

Data will be collected at a convention in the fall and shaped into a narrative. The dimensions discussed by Getz (2012) and Ziakas and Boukas (2014) including socializing, sense of change, accomplishment engagement, involvement, transformation, and memorability are some anticipated themes as found in the literature. The limitations include selective nonresponse to ESM signals, dependence on research subjectivity, participant deceit, and the results are unlikely to be replicated given the context.

Events researchers must explore experiences further, and phenomenology can help. An approach exploring real-time planner/attendee perspectives provides insight into the experience, and highlights meanings and issues that occur on-site that may not be remembered. This narrative may lead into managerial implications like identifying gaps in attendee needs. This may lead towards enhancing attendee's satisfaction impacting future behaviors like return intention or word-of-mouth.

REFERENCES

Convention Industry Council. (2014). Fact sheet. The Economic Significance of Meetings to the U.S. Economy. Retrieved from <http://www.conventionindustry.org/>

Csikszentmihalyi, M. (1990). *Flow: The psychology of optimal experience* (1st ed.). New York, NY: Harper & Row.

DeCrop, A. (2004). Trustworthiness in qualitative tourism research. In J. Phillimore & L. Goodson (Eds.), *Qualitative research in tourism: Ontologies, epistemologies, and methodologies*, 156-169. New York, NY: Routledge.

Gergen, K. J. (1985). The social constructionist movement in modern psychology. *American Psychologist*, 40(3), 266. doi:10.1037/0003-066x.40.3.266

Getz, D. (2008). Event tourism: Definition, evolution, and research. *Tourism Management*, 29(3), 403-428. doi:10.1016/j.tourman.2007.07.017

Getz, D., & Page, S. J. (2016). *Event studies: Theory, research and policy for planned events*. New York, NY: Routledge.

Hektner, J.M., Schmidt, J.A., & Csikszentmihalyi, M. (2007). *Experience sampling method: Measuring the quality of everyday life*. Thousand Oaks, CA: SAGE Publications.

Lunt, T. (2012). Typologies and event studies. In S.J Page & J Connell (Eds.), *The routledge handbook of events*, 47-56. New York, NY: Routledge.

Meeting Professionals International. (2016). *Future of meetings final report*. Retrieved from <http://www.mpiweb.org/store/product/6736>

Page, S., & Connell, J. (Eds.). (2014). *The routledge handbook of events*. New York, NY: Routledge.

Pine, B. J., & Gilmore, J. H. (1998). Welcome to the experience economy. *Harvard Business Review*, 76(4), 97-105.

Rossmann, J.R. (2003). *Recreation programming: Designing leisure experiences*. Sagamore Publishing.

Ryan, C. (1997). *The tourist experience: A new introduction*. 2nd ed. Cassel. Smith, J.A &

Eatough, V. (2007). Interpretative phenomenological analysis. In E. Lyons & A. Coyle (Eds.), *Analysing qualitative data in psychology*, 51-64. London, UK: SAGE Publications.

Ziakas, V., & Boukas, N. (2014). Contextualizing phenomenology in event management research: Deciphering the meaning of event experiences. *International Journal of Event and Festival Management*, 5(1), 56-73. doi:10.1108/IJEFM-08-2012-00230(2).pdf

THE FUTURE OF FESTIVAL DESIGN IN AN EMERGING HAPPINESS ECONOMY

VERN BIAETT

High Point University, USA

The design and production of events was concentrated on the delivery of quality products and services until it was expanded to include an experience paradigm (Berridge, 2006) following the identification of experience makers (Toffler, 1970) and the acknowledgement of experience industries (O'Sullivan & Spangler, 1998) and the experience economy (Pine & Gilmore, 1999). With the emergence of a modernistic "Happiness Economy" (Gerritsen & Von Olderen, 2014, p.20) the next challenge for festival managers will be to add the orchestration of happiness to the current event design equation.

Familiarity with the historical antecedents of festivity provides a gateway and starting place to understanding this undertaking. The earliest humans spontaneously engaged in turbulent festive activity. This form of highly physical, emotional, sensual, and collaborative play-like celebration (Biaett, 2017) gave rise to mankind's original thoughts of community and well-being (Huizinga, 1955). Progressing civilizations organized festivity, but retained much of its organic essence as church and state leaders allowed, and viewed as beneficial, the release of surplus physical energy and bottled-up emotions. With the Industrial Revolution the turbulent elements of organic festivity disappeared when leisure was restructured as a time to conserve energy for labor (Krause, 1971). The physical, emotional, and sensual turbulence of riotous holiday celebration was supplanted with the passivity and spectatorship of new social gatherings, concerts, circuses, sporting events, markets, and parades. Starting in the 1950's, objective business management approaches further influenced the design of festivity. Pseudo-events were developed to generate media coverage (Boorstin, 1961) and festivals were coveted as redevelopment tools for rural America (Wilson et al. 2001) and strategies for urban regeneration (Foley et al., 2012). Fueled by sponsorship, revenue generation, and social media, festivals were turned in to engines of economic impact (Jackson et al., 2005) and drivers of product and place branding (De Bres & Davis, 2001; Derrett, 2003). The transcendent festive experience, with its spirit of equality, solidarity, and contextual social structure (Turner, 1982), was superseded by mercantile and marketing activity intended to generate revenue and gain attention. Modern festivity became socially and psychologically removed from its turbulent and communal historic organic roots, key factors for the orchestration of happiness.

Well-being is described as something an individual recognizes through one's personal behavior (Campbell, 1981) and at the same time as a term best used for groups (Brummer & Sarot, 1996). Some feel well-being arises from long term life factors (Diener, 2000) while others believe well-being cannot surface only from life circumstances (Campbell, 1981). Diametric viewpoints about the delineation of well-being aside, there exists wide agreement surrounding the descriptions for happiness, satisfaction, and morale (Mannell & Kleiber, 1997). Happiness is that part of well-being represented by present temporary feelings, satisfaction a positive/negative life evaluation gleaned from past experiences, and morale the positive/negative predictions of one's future. Rhetorically connecting these templates to festivity, Cox (1969) shares a revelation that pure festivity occurs during times of fleeting celebration grounded in past memories and future dreams. Similar to the parallel relationship of events and experiences (Berridge, 2006) there is a direct correlation between festivity and happiness.

With these ideas in mind, event managers would be wise to embrace the philosophy of Roger Caillois (1961) who expressed festivity as a period of excess and chaos during which the inbred and boisterous modules of life are temporarily expressed. Happiness arises from organic turbulent festive activity, not spectatorship, not shopping, and not marketing activity. Happiness providing festive environments should be designs that inspire participants to engage in spontaneous physical and collaborative activities such as communal dancing, chanting, singing, clapping, pulling, jumping, or hugging with consequential outcomes of unexpected delight. These environments must concurrently infuse guest's senses. Festivals ought to simultaneously stimulate the brain's visual cortex and primate subdivision with light to make it appear to flicker and pulsate, include scents and smells to inaugurate and invoke strong memories, and vary the level and intensity of sound to arouse and initiate sonic overloads. Altering the modalities of vibration, balance, and temperature are also part of this sensory mix. Finally, designs elements should place visitor emotions on a rollercoaster ride of high peaks, low valleys, sharp turns, and erratic speeds. The choreographing of happiness necessitates adventures of surprise, fear, joy, vulnerability, hesitancy, romance, courage, thrill, mystery, and more to leave participants mentally fatigued.

It is envisioned that employing the organic turbulent factors of festivity in the design of festivals will result in a transformative, liminal, and communal sense of happiness. One not must create a specific experience or sense of happiness as much as foster these to happen. In conclusion, this is only the beginning of the deliberation, reflection, and research that must go into a complete understanding how the design of festivals might proceed in an emergent happiness economy.

REFERENCES

Berridge, G. (2007). *Events Design and Experience*. Burlington, MA: Elsevier.

Biaett, V. (2017). Festivity, Play, Well-Being ... Historical and Rhetorical Relationships: Implications for Communities. In R. Phillips, C. Wong (Eds.) *Handbook of Community Well-Being Research*, pp. 189-198. Dordrecht, Netherlands: Springer.

Boorstin, D. (1961). *The image: A guide to pseudo-events in America*. New York: Harper and Row.

Brummer, V. & Sarot, M. (1996). *Happiness, well-being, and the meaning of life: A dialog of social science and religion*. Kampen, the Netherlands: Pharos Publishing House.

Caillois, R. (1961). *Man, play, and games*. Glencoe, IL: Free Press of Glencoe.

Campbell, A. (1981). *The sense of well-being in America: Recent patterns and trends*. New York: McGraw-Hill.

Coalter, F. (1990). Analyzing leisure policy. In: I.P. Henry (Ed.), *Management and Planning in the Leisure Industries* (pp. 149-178). Basingstoke, UK: Macmillan.

Cox, H. (1969). *The feast of the fools*. Cambridge, MA: Harvard University Press

De Bres, K., & Davis, J. (2001). Celebrating group and place identity: a case study of a new regional festival. *Tourism Geographies*, 3(3), 326-337.

- Derrett, R. (2003). Making sense of how festivals demonstrate a community's sense of place. *Event Management*, 8(1), 49-58
- Diener, E. (2000). Subjective well-being: The science of happiness, and a proposal for national index. *American Psychologist*, 55, 34-43.
- Foley, M., McGillivray, D., & McPherson, G. (2012). *Event policy: From theory to strategy*. New York: Routledge.
- Gerritsen, D. & Van Olderen, R. (2014). *Events as a strategic marketing tool*. Oxfordshire, UK: CABI.
- Huizinga, J. (1955). *Homo ludens: A study in the play element in culture*. Boston: Beacon Press.
- Jackson, J., Houghton, M., Russell, R., & Triandos, P. (2005). Innovations in measuring economic impacts of regional festivals: A do-it-yourself kit. *Journal of Travel Research*, 43(4), 360-367.
- Krause, R. (1971). *Recreation and leisure in modern society*. New York: Appleton- Century Crofts.
- Mannell, R. & Kleiber, D. (1997). *A social psychology of leisure*. State College, PA: Venture Publishing Inc.
- O'Sullivan, E.L., & Spangler, K.J. (1998). *Experience marketing: Strategies for the new millennium*. State College, PA: Venture Publishing.
- Pine, B. & Gilmore, J. (1999). *The experience economy: Work is theatre and every business is a stage*. Boston: Harvard Business School Press.
- Toffler, A. (1970). *Future Shock*. New York: Bantam Books.
- Turner, V. (1982). *Celebration: Studies in festivity and ritual*. Washington, DC: Smithsonian Institution Press.
- Wilson, S., Fesenmaier, D.R., Fesenmaier, J., & Van Es, J.C. (2001). Factors for success in rural tourism development. *Journal of Travel Research*, 40(2), 132.

IMPORTANT CONTEMPORARY MOTIVATORS AND INHIBITORS IN ASSOCIATION DELEGATES' CONFERENCE ATTENDANCE CHOICE

JAMES CASSAR

Bournemouth University, UK

ANYA CHAPMAN

Bournemouth University, UK

JULIE WHITFIELD

Bournemouth University, UK

Conference Tourism is considered a lucrative tourism niche that brings a number of benefits to successful host destinations (Horváth 2011). This has led to fierce competition between host destinations (Hussain et al. 2014). The success of an association conference is often measured by meeting or exceeding attendance predictions (Ramirez et al. 2013). The association delegate may thus be considered the end client of both the conference organiser and the hosting destination (Jago and Deery 2005) as delegates choose whether to attend a conference or not (Tanford et al. 2012). A number of motivating and inhibiting factors, which planners and destinations constantly attempt to understand, direct the delegates' attendance choice.

This study explores the factors that have an impact on the association delegate's choice of attending a conference and attempts to classify them in order of importance. The data, collected from association delegates, was collected through a self-administered quantitative questionnaire survey and utilised a Likert scale technique to measure the extent of importance of each variable. The questionnaire was carried out at six different international association conferences held in Malta between February 2016 and March 2017, hosting 2050 delegates cumulatively.

A total of 285 delegate responses were collected. The questionnaire included 144 variables of which 82 were potential motivators and 62 were potential barriers to conference attendance. Factor Analysis tests were carried out on the motivators and barriers that scored highest (mean ≥ 4) in order to examine the structure of the factors that mostly affect conference attendance decision making. The Principal Component Analysis (PCA) with orthogonal rotation (VARIMAX) and Kaiser Normalization was employed. By channelling the variables into larger factors the most significant factors that deserve to be prioritised by destinations were singled out.

The results have reaffirmed the significance of a number of traditionally important factors while it also exposed increased importance given to emergent factors. The conventional motivators that this study has reconfirmed importance of included the educational improvement element, conference-related factor and socialisation factor. This thus supports findings in other similar studies (Severt et al. 2007; Zhang et al. 2007; Yoo and Chon 2008; Ryan et al. 2008; Yoo and Zhao 2010; Tanford et al. 2012; Ramirez et al. 2013). Likewise, traditionally important inhibitors to attendance were also identified in this study. Expectedly, cost emerged as one of the barriers. Lack of sanitation, both at the accommodation venue and at the destination, was also considered a problem by delegates. This factor has also been highlighted in other conference literature frequently being referred to as 'hygiene' (Ryan et al. 2008; Yoo and Chon 2008).

This study also revealed a much stronger delegate reliance on technology than previously predicted. The variables forming the technology component factor were rated as the most

important amongst both the motivating and inhibiting variables. Fast Wi-Fi was identified as the strongest motivator to delegate attendance while lack of Wi-Fi at the conference venue was considered the strongest inhibiting variable, followed by slow Wi-Fi in second place. Lack of Wi-Fi at the accommodation venue was also ranked as an important barrier, making the Technology-related factor the strongest by far. Wi-Fi has been identified before, mostly in studies amongst millennials (Fenich et al. 2014), but the importance given to it varied according to continent of origin of respondents. Furthermore this study reveals the importance of the availability of power supplies for delegates which past studies have failed to identify altogether.

Finally, this study reaffirms the importance delegates give to the destination's safety. While safety in general has been conventionally considered important by delegates (Mair and Thompson 2009) this study reveals the importance given by delegates to the specific safety issue of terrorism within the safety factor. Authors (Crouch and Louviere 2004) have predicted the possible increase in importance delegates would give to such variable, but it has not been highlighted in delegate attendance studies.

Such findings imply that the immense importance given to technology indicates that variables such as Wi-Fi and power supplies have become a pre-requisite, rather than an add-on to the conference experience. This study's results suggest that conference organisers and destinations should pro-act in terms of technology and ensure that their destination and venues satisfy the increasing technological needs of the delegates. Increased research on other important technology variables is also being suggested. Furthermore the increased need to connect online by delegates suggests that the future structure of the conference might change, possibly increasing breaks to ensure that all delegates are satisfying their need to connect, and being able to concentrate during the sessions themselves. Planners should also increasingly use technology to the conference's advantage, by increasing communication through apps and introducing interactive seminar speeches. With regards to terrorism, a destination needs to uphold its reputation as being safe. Studying the duration of negative effects following terrorist attacks might be beneficial when planning promotional strategies, such as increasing levels of security and offering guarantees against terrorism.

REFERENCES

Crouch, G. I., & Louviere, J. J. (2004). The determinants of convention site selection: A logistic choice model from experimental data. *Journal of travel research*, 43(2), 118-130.

Fenich, G. G. (2001). Towards a conceptual framework for assessing community attractiveness for conventions. In *Journal of Convention & Exhibition Management* (Vol. 3, No. 1, pp. 45-64). Taylor & Francis Group.

Horvath, Z. (2011). The economic impacts of conference tourism in Siofok, the "capital" of Lake Balaton. *GeoJournal of Tourism and Geosites*, 4(1), 75-86.

Hussain, K., Ragavan, N. A., Kumar, J., & Nayve Jr, R. M. (2014). Micro-impacts and Benefits of Business Tourism in Malaysia: A Case Study of Kuala Lumpur Convention Centre. *Asia-Pacific Journal of Innovation in Hospitality and Tourism (APJIHT)*, 3(1), 1-24.

Jago, L. K., & Deery, M. (2005). Relationships and factors influencing convention decision-making. In *Journal of Convention & Event Tourism* (Vol. 7, No. 1, pp. 23-41). Taylor & Francis Group.

- Mair, J. (2010). Profiling conference delegates using attendance motivations. In *Journal of Convention & Event Tourism*, 11 (3) 176-194.
- Mair, J., & Thompson, K. (2009). The UK association conference attendance decision-making process. *Tourism Management*, 30(3), 400-409.
- Ramirez, D., Laing, J., & Mair, J. (2013). Exploring intentions to attend a convention: a gender perspective. *Event Management*, 17(2), 165-178.
- Ryan, C., Crotts, J., & Litvin, S. (2008). Convention center management—Influencing the attendee experience: The case of Charleston convention center. *Tourism Analysis*, 13(2), 157-169.
- Severt, D., Wang, Y., Chen, P. J., & Breiter, D. (2007). Examining the motivation, perceived performance, and behavioral intentions of convention attendees: Evidence from a regional conference. *Tourism Management*, 28(2), 399-408.
- Tanford, S., Montgomery, R., & Nelson, K. B. (2012). Factors that influence attendance, satisfaction, and loyalty for conventions. In *Journal of Convention & Event Tourism* , 13, (4) 290-318.
- Yoo, J. J. E., & Chon, K. (2008). Factors affecting convention participation decision-making: Developing a measurement scale. *Journal of Travel Research*, 47(1), 113-122.
- Yoo, J. J. E., & Zhao, X. (2010). Revisiting determinants of convention participation decision making. *Journal of Travel & Tourism Marketing*, 27(2), 179-192.
- Zhang, H. Q., Leung, V., & Qu, H. (2007). A refined model of factors affecting convention participation decision-making. *Tourism Management*, 28(4), 1123-1127.

EFFICIENT USE OF DATA RESOURCES USING THE EXAMPLE OF MEETINGS AND EVENTS INDUSTRY MANAGEMENT IN POLAND

KRZYSZTOF CELUCH

Warsaw School of Tourism and Hospitality Management, Poland

EWA DZIEDZIC

SGH Warsaw School of Economics, Poland

INTRODUCTION

The main purpose is to showcase the results specifying the number, sizes of meetings and events organized in Poland in 2013 and to show their economic value. In addition, the research presents a profile of participants, the characteristics of the meetings organized by the recommended organizers. The research consists of 18100 meetings and events, which are shown in quantitative and qualitative terms. In addition, there is another analysis of cities and regions and the continuation of research into profiles of participants of meetings held in Poland.

THEORETICAL FOUNDATION(S) / REVIEW OF THE LITERATURE

A “meeting” can be defined as a gathering of several or many people in one place and/or at the same time in order to discuss, exchange views and experiences, debate, present products, share knowledge and ideas, as well as to learn and motivate. The meeting in question might be arranged on a one-off basis or regularly, with certain seasonality. As defined by Convention Industry Council (CIC), the term refers to a gathering that fulfils the criteria of 10 or more participants meeting for a minimum of four hours in a contracted venue/destination [Measuring..., 2006].

The acceptance of these assumptions determines what types of meetings will constitute the subject of research into the industry. As “meetings industry” also tends to be used as a synonym of business tourism, it is worth emphasising the fundamental difference between the two terms. The scope of business tourism, understood as a synonym of business trips, encompasses also individual business trips, whose participants do not attend meetings (as defined by CIC) and thus cannot be comprehended as part of business tourism [Borodako et al., 2015, p. 13]. The meetings industry, on the other hand, also involves aspects that remain outside the scope of business tourism. Meetings, after all, might have a local character and then do not require their participants to travel and/or leave their place of residence and seek overnight accommodation. In other words, these cases are distinguished by the lack of features determining the emergence of tourism. The discussed meetings have local participants gathering in one place, usually people personally involved in a given issue or interested in the discussed subject matter exerting a direct or indirect impact on themselves or their surroundings. The “MICE” acronym (or “MICE tourism”) is another term of English origin that until recently has been widely applied in foreign and domestic studies. The acronym was formed by combining the first letters of the words Meetings, Incentive, Conventions, Exhibitions or Meetings, Incentive, Congresses, Events, thus indicating which categories of meetings it encompasses. The name first became highly popular in literature on the subject, but recently is increasingly less frequent owing to a certain semantic awkwardness for English speakers [Berbeka et al. 2009, p. 13]. For people insufficiently informed about business tourism, the “MICE” term might create an inappropriate picture of the market, as a consequence reducing its economic rank [Fullforms, 2013]. In addition, the emergence of new

types of meetings, which fall outside the scope defined by the big four, also contributed to “MICE tourism” losing its relevance.

RESEARCH METHODOLOGY

The analysis presented in this research is traditionally based on standards adopted in the study of tourism related to meetings "Measuring the Economic Importance of the Meetings Industry Developing a Tourism Satellite Account Extension" developed by the World Tourism Organization (UNWTO) and affiliated members. According to the UNWTO standards statistical studies take into account meetings and events meeting such conditions as: participation of a minimum of 10 participants, duration of at least half a day, i.e. four hours and more, the place (facility) in which the meeting takes place was paid specifically for this purpose.

Methodology is obviously a factor of crucial importance for the credibility of results. It is essential to take into consideration the expenditures of both the supply and demand sides of the market, paying particular attention not to examine the same streams twice.

The IO analysis was frequently applied in works dedicated to the economic contribution of domestic and international meetings [Rutherford and Kreck, 1994; Mistilis and Dwyer, 1999; Dwyer et al., 2000; Kim et al., 2003; Lee, 2006; Kim and Chon, 2009; Lee et al., 2013]. The main goal of the models is to measure the co-dependency of particular industries within a given economy [Miller and Blair, 2009]. It remains debatable whether the expenditures of local residents should also be taken into account. The opponents point out that we are dealing with a mere redistribution of resources [Southwick et al., 2009], which is not synonymous with making an economic impact. According to other opinions, the expenses of local residents contribute to the creation of new jobs and thus should be taken into consideration [Dae-Kwan et al., 2015]. Early research conducted back in the 1990s [Falk and Pizam, 1991; Braun and Rungeling, 1992; Lee, 2006] focused exclusively on the expenditures of participants. This approach was inspired by the complex character of the meetings industry and problems with arranging the research process [Dwyer, 2002; Lee et al., 2013].

The first comprehensive approach was aimed at estimating the impact of the meetings industry in Orlando, Florida, and encompassed direct and indirect multipliers and an analysis of the industry's interrelationships [Braun, 1992]. The study was expanded by Dwyer and Forsyth [1996], whose research framework was intended to estimate the overall impact and featured induced multiplying factors next to direct and indirect multipliers. In addition, Mistilis and Dwyer [1999] attempted to evaluate the MICE impact on a region, but focused on indicating the differences between urban and nonurban areas.

RESEARCH FINDINGS

The research contains a presentation of expenditure profile of participants in business meetings in 2013. A total of 500 surveys were obtained from participants of the fair and 189 participants of congresses. Among the surveyed participants of congresses, foreigners prevailed (50%), and among the attendees of the fairs Polish residents living outside the voivodeship in which the place of the fair was located (60%).

The average duration of the congresses, during which the study was conducted amounted to 3,857 day, and the average length of stay of the participant - 4.35 days (+/- 7.6%). This means that some of the participants lived in the place of congress longer than its duration. The

estimated average number of nights in accommodation is 2.88 (+/-12.9%). The average daily expenditure on accommodation amounted to PLN 204.2 (+/-13.1). When it comes to spending on food, shopping and transportation, the obtained estimates are characterized by little precision. What is interesting is that less than 37% of the respondents declared using food services.

When it comes to the average duration of the fair, during which the study was carried out, it amounted to 3,514 days and estimated time of participation in the fair by their participants is 2.69 (+/-4.7%). The average number of nights associated with participation in trade fairs is 1.44 (+9%). This relatively small value stems from the fact that a large proportion of the guests are inhabitants of the voivodeship where they are taking place. The average daily expenditure on accommodation rated for participants of the fair is at PLN 86.8 (+/-12.3%). In the case of the fairs, the data collected allow a relatively precise estimate of the daily expenditure on food and beverage services and for the use of cars and taxis. The former amounted to PLN 25.6 (+/-19.9%) and the other PLN 23.7 (+/-15.1%).

CONCLUSION AND IMPLICATIONS

A key message from the research is, first and foremost, the estimated number of nights purchased by participants in the meetings and events in 2013, which is approx. 5,19 million, accounting for approx. 15.9% of total accommodation provided that year in Poland. The sales volume of accommodation services is established using the previously presented estimates of the number of nights and information concerning the estimates of expenditure on accommodation services

amounting to PLN 230 per night. The volume of sales of accommodation services assessed in this way amounted to approx. PLN 1 195 million (approx. 6%). If we use sales volume ratio per working person, we can calculate that the meetings industry has contributed to the creation of jobs for more than 7700 people. Its added value is about PLN 580 million on a national scale.

REFERENCES

Alcover, A., Alemany, M., Jacob, M., Payeras, M., Garcia, A., and Martinez-Ribes, L. (2011), 'The economic impact of yacht charter tourism on the Balearic economy', *Tourism Economics*, Vol 17, No 3, pp 625–638.

Borodako K., Berbeka J., Rudnicki M., 2015, *Zarządzanie innowacjami w przemyśle spotkań*, C.H. Beck, Warszawa 2015.

Braun, B.M., and Rungeling, B. (1992), 'The relative economic impact of convention and tourist visitors on a regional economy: a case study', *International Journal of Hospitality Management*, Vol 11, No 1, pp 65–71.

Braun, B.M., Xander, J.A., and White, K.R. (2002), 'The impact of the cruise industry on a region's economy: a case study of Port Canaveral, Florida', *Tourism Economics*, Vol 8, No 3, pp 281–288.

Celuch K., (2014), *Przemysł spotkań. Wiedza, produkt, motywacja*, Szkoła Główna Turystyki i Rekreacji, Warszawa

Celuch K. Raport Przemysł spotkań i wydarzeń w Polsce, Poland Convention Bureau POT, Warszawa, 2012 - 2016

Celuch, K. Przemysł spotkań. Wiedza, produkt, motywacja, Warszawa 2014, s. 14 – 15

Celuch K., Leksykon przemysłu spotkań, Biblioteka Meeting Plannera 2015, str. 35
Raport Polskiej Izby Przemysłu Targowego, Targi w Polsce w 2014 roku.

CIC (2011), 'The economic significant of meetings to the U.S. economy' (<http://www.pcma.org/resources/research/study-the-economic-significance-ofmeetings-to-the-us-economy.htm>, accessed 25 March 2012).

Convention Industry Council (CIC) (2005), Economic Impact Study: The Economic Impact Of Conventions, Exhibitions, Meetings And Incentive Travel, CIC, Alexandria, VA.

Crompton, J.L., Lee, S., and Shuster, T.J. (2001), 'A guide for undertaking economic impact studies:the Springfest example', Journal of Travel Research, Vol 40, No 1, pp 79–87.

Dae-Kwan K., Hak-Jun K., Sang-Min L. , Yeongbae Ch., Soo-Yeop S., An estimation of the contribution of the international meeting industry to the Korean national economy based on input– output analysis, Tourism Economics, 2015, 21 (3), 649–667.

Deery, M., Jago, L., Fredline, L., and Dwyer, L. (2005), The National Business Events Sector: an Evaluation of the Australian Business Events Sector, Common Ground, Melbourne.

Dwyer, L. (2002), 'Economic contribution of conventions', in Weber, K., and Chon, K., eds, Convention Tourism: International Research and Industry Perspectives, Haworth Press, Binghamton, pp 21–36.

Dwyer, L., Deery, M., Jago, L., Spurr, R., and Fredline, L. (2007), 'Adapting the tourism satellite account conceptual framework to measure the economic importance of the meetings industry', Tourism Analysis, Vol 12, pp 247–255.

Dwyer, L., Mellor, R., Mistilis, N., and Mules, T. (2000), 'A framework for assessing tangible and intangible impacts of events and conventions', Event Management, Vol 6, No 1, pp 175-189.

Falk, E.T., and Pizam, A. (1991), 'The United States' meetings market', International Journal of Hospitality Management, Vol 10, No 2, pp 111–118.

Kashian, R., and Pfeifer-Luckett, R. (2011), 'The economic impact of organized camps', Tourism Economics, Vol 17, No 4, pp 905–916.

Kim, S.S., and Chon, K. (2009), 'An economic impact analysis of the Korean exhibition industry', International Journal of Tourism Research, Vol 11, No 3, pp 311–318.

Kim, S.S., Chon, K., and Chung. K. (2003), 'Convention industry in South Korea: an economic impact analysis', Tourism Management, Vol 24, No 5, pp 533–541.

Korea Tourism Organization (KTO) (2008), *Economic Impacts of International Convention Held In 2007*, Governmental report, Seoul.

Lee, C., Lee, M., and Yoon, S. (2013), 'Estimating the economic impact of convention and exhibition business, using a regional input–output model: a case study of the Daejeon Convention Center in South Korea', *Asia Pacific Journal of Tourism Research*, Vol 18, No 4, pp 330–353.

Lee, M. (2006), 'Analytical reflections on the economic impact assessment of convention and special events', *Journal of Convention & Event Tourism*, Vol 8, No 3, pp 71–85.

Mistilis, N., and Dwyer, L. (1999), 'Tourism gateways and regional economies: the distributional impacts of MICE', *International Journal of Tourism Research*, Vol 1, No 6, pp 441–457.

Murillo Viu, J., Romaní Fernández, J., and Suriñach Caralt, J. (2008), 'The impact of heritage tourism on an urban economy: the case of Granada and the Alhambra', *Tourism Economics*, Vol 14, No 2, pp 361–376.

Rutherford, D.G., and Kreck, L.A. (1994), 'Conventions and tourism: financial add-on or myth? Report of a study in one state', *Journal of Travel & Tourism Marketing*, Vol 3, No 1, pp 49–63.

Saayman, M., and Rossouw, R. (2011), 'The significance of festivals to regional economies: measuring the economic value of the Grahamstown National Arts Festival in South Africa', *Tourism Economics*, Vol 17, No 3, pp 603–624

Southwick, R., Bergstrom, J., and Wall, C. (2009), 'The economic contributions of human-powered outdoor recreation to the US economy', *Tourism Economics*, Vol 15, No 4, pp 709–733.

Tohmo, T. (2005), 'Economic impacts of cultural events on local economies: an input–output analysis of the Kausinen Folk Music Festival', *Tourism Economics*, Vol 11, No 3, pp 431–451.

Weber, K., and Ladkin, A. (2004), 'Trends affecting the convention industry in the 21st century', *Journal of Convention & Event Tourism*, Vol 6, No 4, pp 47–63.

THE “ALE” IN FEMALE: THE FEMININE VOICE AT A CRAFT BEER FERMENTATION FEST

WILLEM COETZEE

University of Otago, New Zealand

CRAIG LEE

University of Otago, New Zealand

PURPOSE

The modern economy has been characterised by a shift from a product/service-based economy to an experience-based economy valuing the delivery of memorable and high-quality experiences to customers which in turn determine a business' ability to generate revenue (Pine & Gilmore, 1999). Thus, to stage an experience at events, it is imperative to identify the needs and motivations of attendees. However, it is important to be cognizant that tourists' different interests and backgrounds lead to diverse interpretations for a single tourist product (Kim, Ritchie & McCormick, 2012; Ooi, 2005). Kruger & Saayman (2015) are of the opinion that regarding interpretation, women and men are involved differently in the construction and consumption of events. Swain (1995) states that gendered realities shape marketing, guests' motivations, and hosts' actions. Learning about the interests and activities from a gendered perspective is thus vital to the planning and marketing of tourism products (Meng & Uysal, 2008). The failure to fully recognise and integrate gender perspectives with the design and marketing of tourist products would lead to gender-blind marketing and consumer dissatisfaction (Kruger & Saayman, 2015). This can also be said for marketing of events, such as a beer festival.

Beer may not come to mind as a warm and welcoming environment for women in management. Indeed, few other mainstream industries utilize advertising as openly hostile to women. In contrast to the 2% CEO positions held by women in Fortune 500 firms, 20% of U. S. large and medium sized malt brewing companies are headed by women. Regarding craft beer festivals, South Florida hosted the first-ever festival celebrating women in the brewing industry on Memorial day Weekend (May 28, 2017) in FAT Art District. This festival hosted a large selection of female-run breweries from local female run establishments. The event organiser stated that according to their research women are responsible for 32% of craft beer consumption figures in the USA. According to the Editor of Beverage World, Jeff Cioletti, the craft beer/female connection is obviously nothing new, especially when you look at the leaders behind notable breweries. Women craft beer aficionados have been an increasingly prominent force through blogs like thebeerchicks.com; drinkwiththewench.com and BeerGoggins.com and endeavours such as Ladies of Craft Beer. "Women are a large and growing market for craft breweries," said Taste of Brew's event director Jennifer Hernandez. "It is exciting to see the passion and excitement that full-flavored craft beers are generating among women attending Taste of Brews." In this article the author question if women in New Zealand share the same enthusiasm for craft beer.

The purpose of this article is to extend existing gender research by segmenting visitors to a local craft beers festival, namely the Dunedin Craft Beer and Food Festival (DCBF) in New Zealand, using gender as a segmentation base. An online survey was conducted the day after the festival and 436 completed questionnaires were included in the analysis. Independent t-tests as well as two-way frequency tables were used to profile attendees and to compare the differences between females and males who attended the festival. The results suggest that

there are enough differences regarding gender preferences to event organisers to pay attention to when organising events such as a craft beer festival. The results further suggest that craft beer is as popular with female connoisseurs as it is with the male beer drinkers.

METHODOLOGY

An online survey was undertaken the day after the festival. Attendees could only purchase tickets online, and the researcher used that database to distribute the questionnaire to all the email address used when purchasing the tickets. A total of 436 completed questionnaires were received back on Qualtrics with an almost equal number regarding gender (Female N=202 / Male N=234. In populations of 5 000 (N), the respondents would be seen as representative and result in a 95% level of confidence with a $\pm 5\%$ sample error. The questionnaire was divided into two section where section A captured demographic details and section B captured motivational factors measuring items on a 5-point Likert scale. The questionnaire was validated by using content validity (literature analysis); face validity (statistical consultation); construct validity (factor analysis) and reliability (Cronbach's alpha). Data was analysed on SPSS and exploratory principle axis factor analysis, using PCA with Varimax rotation on the motivation item.

FINDINGS

Almost equal percentages of female/male respondents were present. The factor analysis identified seven factors and these were labelled according to characteristics in Table 1. The results indicated that to create a memorable experience, men place significantly higher importance than women on quality alcoholic beverages. Women placed significantly higher importance for a memorable experience compared to men. When asked to rate on a 5-point scale of importance on why they attended the DCBF, men placed significantly higher importance than women on the following reasons why they attended the beer festival; meet people with similar interests; have beer; try new beers; exchange ideas; learn about craft beer; experience a range of beers and compare my home brewed beers with others. Women placed significantly higher importance than men on the following reasons why they attended the beer festival: to see my favourite artist/performer; attend as many local festivals as possible; enjoy the music; relax from daily stress: escape from my busy everyday environment; do something exciting; to see The Black Seeds and because it is a local Dunedin event. An important finding to emerge in this study is males are just concerned about the beer, while women consider some other factors. The results are significant for three important reasons why attendees attended the festival (mean score higher than 4): to have fun (4.33); to try new beers (4.19) and to experience a range of different beers (4.20).

PRACTICAL IMPLICATIONS

This research had investigated the difference between males and females at a type of festival that is often perceived as a male dominated event. The study set out to explore different factors that might influence experiences. The purpose of the present research was to extend existing gender research by segmenting visitors to a local craft beers festival (DCBF) using gender as a segmentation base. The study has shown that there are significant differences between the sexes. However, the findings are subject to at least two limitations. The most significant were that the research was done at only one beer festival and results cannot be generalised to all beer festivals. It is therefore recommended that this research should be conducted over a period as well as difference beer festivals in different destinations. Further research should be done to investigate the gender segmentation at other beer festivals, and future research should

concentrate on Event Experience Scales to better understand a universal scale to measure experiences at festivals. Another limitation is that the research excludes participants that would classify as neither male nor female.

VALUE

The value of this research is to assist organiser to create memorable experiences for different genders at beer festivals. Experience seeking are different among different gender groups and that women are a new emerging market in a market that used to be dominated by males.

Table 1
RESULTS OF FACTOR ANALYSIS AND GENDER COMPARISON

Motivation factors and Items	Loading	Male (N=234)		Female (N=202)				
		Mean	SD	Mean	SD	df	t-value	p
Factor 1: Experiencing Beer								
To try new beers	.902	4.50	.765	3.83	1.182	334.938	-6.892	.000
Experience a range of different beers	.893	4.46	.813	3.89	1.136	357.664	-5.896	.000
To have beer	.797	4.26	.877	3.61	1.246	353.764	-6.222	.000
To taste local beverages	.659	3.90	1.025	3.79	1.002	434	-1.176	.240
Learn about craft beer	.601	3.39	1.119	3.15	1.202	434	-2.117	.035
To experience new things	.464	3.81	.977	3.84	1.029	434	.352	.725
Factor 2: Local event experience								
To attend many local festivals possible	.759	2.11	1.087	2.45	1.246	402.078	3.008	.003
The festival is unique	.662	3.15	1.219	3.29	1.154	434	1.210	.227
It is an annual commitment	.646	2.35	1.385	2.33	1.464	434	-.106	.916
Because it is a Dunedin event	.645	3.18	1.208	3.49	1.156	434	2.769	.006
This festival is value for money	.511	3.24	1.002	3.33	1.081	434	.968	.334
For nostalgic reasons	.452	1.79	1.002	1.82	1.098	434	.218	.827
Factor 3: Socialization and fun								
It is a sociable event	.777	3.71	.890	3.88	.930	434	1.960	.051
Spend time with family and friends	.759	3.48	1.045	3.61	1.124	434	1.260	.208
To socialise	.669	3.45	1.048	3.54	1.070	434	.852	.395
To be with people enjoying themselves	.622	3.23	1.078	3.25	1.181	434	.240	.810
To have fun	.571	4.32	.760	4.35	.732	434	.422	.673
Factor 4: Music & Artist affiliation								
To see The Black Seeds	.884	2.32	1.266	2.78	1.460	400.880	3.468	.001
To enjoy the music	.794	3.04	1.275	3.53	1.286	434	3.996	.000
To see my favourite artist / performer	.785	1.71	1.045	2.19	1.326	380.139	4.219	.000
Factor 5: Ideas Factory								
Exchange ideas with brewers	.802	1.83	1.114	1.62	1.040	434	-1.979	.048
Compare my home-brewed beer	.714	1.82	1.228	1.56	1.106	433.210	-2.254	.025
To see the seminars	.709	1.71	.943	1.71	.869	434	-.751	.453
To meet people with similar interests	.468	2.82	1.248	2.52	1.251	434	-2.429	.016
Factor 6: Relaxation								
To escape from busy every day environment	.432	2.96	1.263	3.23	1.300	434	2.200	.028
To relax from daily stress	.856	3.15	1.182	3.39	1.167	434	2.096	.037
To be seen by others	.847	1.42	.761	1.45	.930	434	.391	.696
Factor 7: Food experience								
To taste unique cuisine	.841	3.37	1.066	3.47	1.155	434	.879	.380
To try a range of foods	.823	3.42	1.129	3.55	1.180	434	1.186	.236

REFERENCES

- Kim, J. H., Ritchie, J. B., & McCormick, B. (2012). Development of a scale to measure memorable tourism experiences. *Journal of Travel Research*, 51(1), 12-25.
- Kruger, M., & Saayman, M. (2015). Attendance at the U2 Concert: Is it a Case of "This is a Man's World?". *Event management*, 19(1), 15-32.
- Meng, F., & Uysal, M. (2008). Effects of gender differences on perceptions of destination attributes, motivations, and travel values: An examination of a nature-based resort destination. *Journal of Sustainable Tourism*, 16(4), 445-466.

Pine, B. J., & Gilmore, J. H. (1999). *The experience economy: work is theatre & every business a stage*. Harvard Business Press.

Ooi, C. S. (2005). A theory of tourism experiences. In *Experiencescapes*.

SPENDING BEHAVIOR AND MUSIC INTEREST IN SIDS: THE CASE OF THE ARUBA SUMMER MUSIC FESTIVAL

ROBERTICO CROES

University of Central Florida, USA

MANUEL RIVERA

University of Central Florida, USA

KELLY SEMRAD

University of Central Florida, USA

VALERIYA SHAPOVAL

University of Central Florida, USA

PURPOSE

This study investigates the relationship between spending behavior and tourism motives to attend a music festival. In recent times, there has been a notable worldwide increase in the production of festival events. This increase has revealed new social realities and needs for tourism destination managers to address. Music festivals are unique special events of short duration and have been a key aspect of tourism to expand the tourist base of destinations. Richards and Wilson (2007) have provided a descriptor to characterize the process of introducing festivals as tourist attractions in a destination portfolio as the “festivalization” of tourism.

Studies have examined the utility, or economic benefits that result from music festivals. The most common assessment applied to determine the economic efficacy of music festivals is the impact approach. This approach ascertains the spending of tourists, organizers, and changes in businesses resulting from the festival production as estimated via the local economy (Thrane, 2002). However, literature has largely overlooked the examination of tourists’ motivations to attend music festivals (Bowen and Daniels, 2005; Pegg and Patterson, 2010). Yet, the extant literature has identified several motivations to attend music festivals including - mainly the enjoyment of the music (Abreau-Novais and Arcodia, 2013). What is lacking in the literature is the investigation of the links between tourists’ motivations and spending. Further, even a scant examination of this potential association in a small island destination (SID) context is conspicuously lacking.

The study pertains to the SID of Aruba and centers on four research questions:

1. Are tourism expenditures related to music festival motives?
2. How are tourism expenditures related to music festival motives?
3. Is there a spending difference amongst different types of music festival tourists?
4. Is there a difference in motives to attend a music festival amongst different festival tourists?

DESIGN/METHODOLOGY/APPROACH

SIDs expend efforts to curb seasonality and to increase demand by organizing cultural events (Croes and Semrad, 2015). The Aruba Tourism Authority (ATA) has created and sponsored an extensive events portfolio that includes several music festivals (Rivera et al, 2015). The major

aim of this music festival portfolio is to reduce seasonality, discover potential market segments, strengthen loyalty, and enhance the destination image (Croes et al., 2011). Aruba has successfully mitigated seasonality effects with the inclusion of the Aruba Summer Music Festival (ASMF). The ASMF is one of the most successful music festivals that the ATA has added to its events portfolio. The music festival takes place at the end of June or early July and draws nearly 10,000 attendees. Its music theme is centered on celebrating Latin music, which includes all the Latin music genres and aims to attract international Latin music aficionados from the USA and Latin America and the Caribbean.

The research design consists of a survey instrument to acquire information from respondents attending a music festival in Aruba. The survey design is grounded in a theoretical framework founded on “the experience economy” of Pine and Gilmore that reflects the overall tourist experience while at a music festival. The survey queries the reason for attending the festival, how respondents evaluate their festival experiences, isolates respondents’ demographic profiles, and asks about their spending.

Motive is defined as a multidimensional construct that refers to the driving force that relates to a person’s behavior (Croes and Lee, 2015). The construct was measured using three items:

“Music is the motive for attending the festival.”

“This year’s artists have a special appeal to me that motivates me to attend.”

“My motive for attending the festival is to join my friends/family.”

A 7-point Likert scale is used to measure the construct and is anchored from 1 (Completely Disagree) to 7 (Completely Agree).

Economic impact is defined as “the economic contribution of a given industry or activity on a defined geographical area or community” (Davies, Coleman and Ramchandani, 2013). The construct is measured by the following tourist spending categories while on the island to attend the music festival: tickets (entry fee), lodging, car rental, transportation to the festival, food and beverage, gasoline, festival souvenirs, shopping, taxi, nightlife (bars and pubs), casino, and other spending. In addition, the survey included a question regarding the tourist party size.

The study applies an ordinary least squares (OLS) regression analysis to estimate three models following Thrane (2002). Each model consists of the three motives as independent variables. The study considers two groups of tourists: 1) those who reported that music was a very important motive to attend, and 2) those who considered music of lesser importance.

Model 1 applies a linear specification. The expectation is that this linear model may be problematic due to heteroscedasticity. Model 2 is specified as a semi logarithmic regression to resolve potential heteroscedasticity as:

$$\text{Log Expi} = a + \sum bY_i + e_i$$

Finally, model 3 also includes several intervening variables that may shape the relationship between motivation and spending. Variables include: age, gender, income, source market, education, party size, and length of stay. The model is specified as follows:

$$\text{Log Expi} = a + bY_i + \sum c_j X_{ij} + e_i$$

FINDINGS

Data were collected in June of 2017 over a two night period and 390 surveys were intercepted. Overall, respondents were from Generation Y with the majority being females (63.1%). Nearly 80% had an income exceeding \$75,000.00 and were highly educated. 73.2% reported they have visited the destination before, while only 36.8% were repeat attendees of the festival. Nearly 60% of respondents came to the island with the main purpose of attending the festival.

The main motive to attend the festival was the artists' lineup (89%), followed by music genre (88%), and joining friends and relatives (84%). These results follow previous research regarding music festivals and tourism. The total direct spending was estimated based on the money tourists and organizers spent in the economy which totaled nearly \$6.2 million, and the spending per day per person was \$279.00. The average length of stay was nearly eight nights.

The study also found significant impact of the independent variables on spending behavior. Those who considered music as a very important motive to attend the festival spend more money than those who considered music of lesser importance. The intervening variables in the models had the expected results.

RESEARCH LIMITATIONS/IMPLICATIONS

The results suggest that motive may be more important than other factors in determining choice. The results also provide evidence that motivation may be related to the music festival. This means that a music festival will attract music aficionados whose motivation intensities may vary. The variation in motivation intensities seem to correlate with demographic characteristics and tourist behavior. The variation in motivation intensities may affect the music aficionado's spending level. Therefore, this study advances the hypothesis that motivation intensity influences the spending level of a music aficionado. This study also contributes to shedding light regarding how the association between motivation intensity and spending levels takes place in a SID.

The limitation of this study is related to the external validation of its findings. The study only focuses on one point in time (2017) and may have been influenced by randomness. The influence of context may have colored the results limiting the ability to apply the model to different contexts in defining the relationship between motives and spending.

PRACTICAL IMPLICATIONS

The main practical implication is that music festivals may be important for increasing and discovering tourist demand to a SID. Marketing strategies based on profiling through motivation intensity to attend a music festival can generate higher spending at a festival and destinations. Finally, evidence-based information sheds meaningful insights into marketing efforts and a rigorous assessment of the music festival benefits to justify financial assistance offered by SIDs' governments.

ORIGINALITY/VALUE

This study is the first examination of the relationship between tourists' motivations and spending at a small island destination music festival.

REFERENCES

- Abreau-Novais, M. & Arcodia, C. (2013). Music festival motivators for attendance: developing an agenda for research. *International Journal for Event Management*, 8(1), 34-48.
- Bowen, H. & Daniels, M. (2005). Does the music matter? Motivations for attending a music festival. *Event Management*, 9, 155-164.
- Croes, R., Rivera, M., Pizam, A, Olson, E., Lee, S. & Zhong, Y. (2011). *Winning the Future in the 21st Century: A Tourism Strategic Plan for Aruba of How to*. Aruba Tourism Authority. Dick Pope Sr. Institute for Tourism Studies: Orlando, FL.
- Croes, R., & Lee, S. (2015). Women at a Music Festival: Biological Sex defining Motivation and behavioral intentions. *Event Management*, 19(2), 275-289.
- Croes, R., & Semrad, K. (2015). The relevance of cultural tourism as the next frontier for small island destinations. *Journal of Hospitality and Tourism Research*, 39, 469-491.
- Davies, L., Coleman, R. & Ramchandani, G. (2013). Evaluating event economic impact: rigour versus reality? *International Journal of Event and Festival Management*, 4(1), 31-42.
- Pegg, S. & Patterson, I. (2010). Rethinking music festivals as a staged event: gaining insights from understanding visitor motivation and the experiences they seek. *Journal of Convention & Event Tourism*. 11(2), 85-99.
- Richards, G. & Wilson, J. (2007). *Tourism, creativity and development*. Routledge: London, UK.
- Rivera, M., Semrad, K., & Croes, R. (2015). The five E's in festival experience in the context of Gen Y: Evidence form a small island destination. *Revista Española de Investigación en Marketing ESIC (REIMKE)*, 19(2), 95-106.
- Thrane, C. (2002). Jazz festival visitors and their expenditures: linking spending patterns to musical interest. *Journal of Travel Research*, 40, 281-286.

THE POWER OF EWOM FOR MUSIC FESTIVALS IN THE EXPERIENCE ECONOMY

KELLY SEMRAD

University of Central Florida, USA

ROBERTICO CROES

University of Central Florida, USA

MANUEL RIVERA

University of Central Florida, USA

PURPOSE

The study investigates whether a music festival may be used as an experiential attraction to draw the Gen Y market segment to a small island destination (SID) as a cohort replacement for the baby boomer generation. It is well documented that the baby boomer generation comprises a large and important market segment in travel and tourism industries (Cleaver et al., 2000; Jang & Ham, 2009; Lehto et al., 2008). As Cohort replacement and generational succession are natural progressions of social life that influence consumer markets and product development (Alwin, 2002) it is important for destinations to supplement a fading segment with a replacement generation. Destination managers must learn to attract tourists of the next generation (Gen Y) through product development and promotional strategies. Thus, it is important for SID managers to realize what types of tourism products will appeal and lure Gen Y travelers.

DESIGN/METHODOLOGY/APPROACH

A total of 274 surveys were collected at a music festival occurring in Aruba. A purposive sampling technique was used to ensure that all respondents were from the Gen Y segment. The constructs used in the model include: education, entertainment, escapism, esthetics, and economic value (5E's). These constructs are considered predictors of memorable festival experiences, and memorable festival experiences are considered an antecedent for Gen Y tourists' eWOM for the festival and/or destination. The research hypotheses are as follows:

H₁: A positive relationship exists between the 5E's (overall experience) and memorable festival experience.

H₂: A positive relationship exists between memorable festival experience and electronic word of mouth (eWOM) for the festival.

The study applied a structural equation model (SEM) to test the causal relationships among the latent variables as proposed in the aforementioned research hypotheses.

FINDINGS

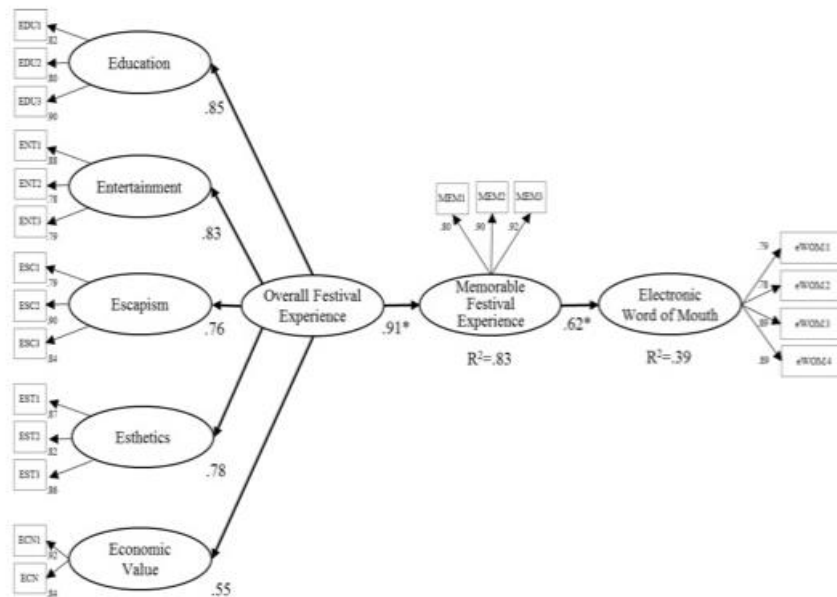

RESEARCH LIMITATIONS/IMPLICATIONS

The study is not without limitations. The results are driven by a quantitative case study analysis and should therefore be replicated in the context of different music festivals, destinations, and a larger representation of Gen Y tourists.

PRACTICAL IMPLICATIONS

The original 5E's in festival experience for the Gen Y framework provided the experiential domains that were necessary to create a memorable music festival occurring in SIDs. However, the original framework assessed whether a memorable music festival would influence the intention of Gen Y tourists to return and promote the festival and destination via traditional WOM. While WOM is a notable marketing asset for destination managers and festival organizers, it does not resonate with the Gen Y cohort like that of eWOM. Traditional WOM also does not provide the expansive market reach that eWOM offers to destination managers and festival organizers striving to reach international tourists by way of a cost-effective means (Bilgihan et al., 2013). Consequently, the current model, which includes eWOM as the dependent variable of interest, is deemed more appropriate for SID managers and festival organizers to reach music festival promotional goals while addressing specific market challenges of operating within a confined island economy.

ORIGINALITY/VALUE

This is the first study to advance the 5E's in festival experience for the Gen Y segment using eWOM.

REFERENCES

Bilgihan, A., Okumus, F., & Cobanoglu, C. (2013). Generation Y travelers' commitment to online social network websites. *Tourism Management*, 35, 13-22.

Cleaver, M., Green, C., & Muller, T. (2000). Using consumer behavior research to understand the baby boomer tourist. *Journal of Hospitality & Tourism Research*, 24(2), 274-287.

Jang, S. & Ham, S. (2009). A double-hurdle analysis of travel expenditure: Baby boomer seniors versus older seniors. *Tourism Management*, 30(3), 37-380.

Lehto, X., Jang, S., Achana, F., & O'Leary, J. (2008). Exploring tourism experience sought: A cohort comparison of Baby Boomers and the Silent Generation. *Journal of Vacation Marketing*, 14(3), 237-252.

Rivera, M., Semrad, K.J., & Croes, R. (2015b). The five E's in festival experience in the context of Gen Y: Evidence from a small island destination. *Revista Española de Investigación en Marketing ESIC*, 19(2), 95-106.

“THIS BLOWS!” – THE IMPACT OF EXTREME WEATHER ON SPORTING EVENTS: THE CASE OF THE CAPE TOWN CYCLE TOUR

JULIA GIDDY

University of Johannesburg, South Africa

PURPOSE

The purpose of this paper is to investigate the impact of extreme weather on tourism events through the perceptions of participants. Both the number and size of major sporting events have been growing globally as well as their economic contribution to host cities (Kurtzman, 2005). This has been done through a case study of a specific event, the Cape Town Cycle Tour, held in Cape Town, South Africa. The Cape Town Cycle Tour is the largest individually timed cycle race in the world, with upwards of 35,000 participants and extending 106 kilometres (Streicher & Saayman, 2010). This event is a major contributor to the economy of Cape Town due to both its size and prestige (Saayman & Saayman, 2012). In 2017, race organizers made the decision to cancel the event attributed to poor weather conditions, primarily extreme wind, just after the event had begun. This study seeks to not only examine participant perceptions of this cancellation but also the potential impact of cancellation on the success of the event in the future.

A number of studies have examined such events, several within the context of South Africa, however, they have focused on either economic aspects of these events or motivations of participants (e.g. Kotze, 2006; Saayman & Saayman, 2012; Streicher & Saayman, 2010). This study seeks to investigate a new dynamic necessary for the success of such events: the influence of extreme weather. Weather patterns have repeatedly been shown to influence tourists' experiences in a number of ways (Becken & Wilson, 2013). The significance of weather increases even more when considered in the context of sport tourism due to the importance of favourable weather conditions on the successful completion as well as the comfort of participants. In recent years, extreme weather patterns have become more common and are likely to continue to increase in number and magnitude based on future climate change predictions. Although a number of studies have examined the influence of weather (Becken & Wilson, 2013) and future climate change on tourism, more broadly (Hoogendoorn & Fitchett, 2016), the influence of weather patterns on the success of major sporting events, within a tourism framework, has not been given much attention.

DESIGN/METHODOLOGY/APPROACH

The primary data used in this paper were collected using a questionnaire distributed to those who were registered for and scheduled to participate in the 2017 Cape Town Cycle Tour. The questionnaire was distributed through online cycling portals and was also distributed to cycling clubs throughout South Africa. The questionnaire included both fixed-response and open-ended questions to elicit a range of information relevant in understanding personal experiences at the event. A total of 139 usable responses were obtained. Fixed-response data was analyzed using basic descriptive statistics while open-ended questions were analyzed, thematicized and categorized.

FINDINGS

Preliminary findings show that the majority of respondents were not from Cape Town (97%), indicating the significance of the event in attracting visitors and most (86%) travelled to Cape

Town specifically for the event. Most have participated in the event before (79%) with several having participated more than 10 times (22%). A number of respondents indicated negative experiences with weather during previous participation. Most respondents (62%) arrived at the start of the race, unaware that it was cancelled, however only 11% were able to begin the race before it was cancelled. Of those who began the race, they were only able to cycle a maximum of 20 kilometres. In terms of experiences at the event, there was mixed sentiment among respondents. There were a number of emotions used to describe the atmosphere at the start, both before and after cancellation. There was widespread disappointment but a number mentioned relief. Prior to cancellation several respondents mentioned feelings of anxiousness due to the weather they experienced getting to the start. Very few injuries were reported, but a number of respondents had been blown off their bicycles. Although the majority (80%) did feel that the weather was sufficiently bad to warrant cancellation, explanations often mentioned worse weather in previous years, particularly among those who had participated in the event in 2009, 2010 and 2015. In addition, a number of other obstacles occurred in Cape Town along the route on race day including fires and protesters barricading the route. A few respondents felt strongly that the wind was, indeed, a factor in cancellation but that these other incidents, particularly protests were also responsible. Interestingly, despite frustrations at the cancellation of the event, 75% of respondents stated that they would participate in the event in the future, while very few said they would not (11%) and the remaining were undecided.

RESEARCH LIMITATIONS/IMPLICATIONS

This study is an exploratory investigation into the impact of extreme weather on sporting events. It provided important insight into the potentially detrimental impacts of extreme weather on sporting events and associated revenue generated. The contribution of these findings to research on the topic of weather and tourism is also significant. Unlike other forms of tourism, according to these results, participants in major sporting events demonstrate a relatively strong sense of loyalty to the event. Furthermore, a single, or even several, negative experiences with weather do not appear to significantly influence future participation. Findings are, however, limited to a single event. A great deal of additional research is needed on the interaction between extreme weather and sporting events as there are significant potential consequences as weather patterns continue to become increasingly unpredictable under climate change predictions.

PRACTICAL IMPLICATIONS

There are many practical implications of these findings. Weather and climate are particularly important in the context of sporting events, since it can influence the safety, comfort and, overall well-being of participants, all of which are crucial for the continued success of major sporting events. It is important for race organizers and host destinations to consider a number of dynamics that will ensure the success of these types of races including changing weather patterns. In addition, the cancellation of the Cape Town Cycle Tour can have substantial financial consequences if these issues are not resolved in future races.

ORIGINALITY/VALUE

This study provides important insight into the impact of extreme weather on the events industry. As one of the largest individual sporting events in the world, the Cape Town Cycle Tour provides an important platform from which the investigation into the influence of extreme weather on events can be spring-boarded. As of yet, an evaluation of participant

reactions to the cancellation of an event of this magnitude due to weather conditions has yet to be published. Furthermore, it provides a unique perspective by discussing these issues within the context of South Africa, an emerging destination for major international sporting events.

REFERENCES

Becken, S. & Wilson, J. (2013). The Impacts of Weather on Tourist Travel. *Tourism Geographies*, 14(4), 620-639.

Hoogendoorn, G. & Fitchett, J.M. (2016). Tourism and Climate Change: A review of threats and adaptation strategies for Africa. *Current Issues in Tourism*, 1-19.

Kotze, N. (2006). Cape Town and the Two Oceans Marathon: The impact of sport tourism. *Urban Forum*, 17(3), 282-293.

Kurtzman, J. (2005). Economic impact: Sport tourism and the city. *Journal of Sport Tourism*, 10(1), 47-71.

Saayman, M. & Saayman, A. (2012). Determinants of Spending: A evaluation of three major sporting events. *International Journal of Tourism Research*, 14, 124-138.

Streicher, H. & Saayman, M. (2010). Travel Motives of Participants in the Cape Argus Pick n Pay Cycle Tour. *African Journal for Research in Sport, Physical Education and Recreation*, 32(1), 121-131.

HOW TO SECURE FUNDING FOR A CONVENTION CENTER AND CVBS: THE CASES OF THE STATE OF FLORIDA AND JAPAN

TADAYUKI HARA

University of Central Florida, USA

KAZUSHIGE FAKUDA

University of Central Florida, USA

INTRODUCTION

This paper aims to investigate how convention and visitor bureaus (CVBs, which can be synonymous to Destination Marketing Organizations) can secure sustainable sources of tourism funding to create convention centers and marketing activities through introducing and continuing the hotel room tax or related travel industry promotion tax (hereinafter, referred to as "tourist tax" in general, if not otherwise specified.). Specifically, this paper focuses on politics and geographic aspects of how tourism policy professionals can introduce the tourist tax by successfully avoiding, minimizing, and dealing with possible local oppositions about the tourist tax.

Firstly, this paper provides the classification frameworks for analyzing different CVBs funding through tourist tax. Secondly, this paper shows case studies of funding CVBs and tourism public infrastructure such as convention centers from tourist tax in Florida with the focus on political debate. Thirdly, this article offers Japanese case studies where Tokyo Metropolitan Government enacted the first hotel tax in 2002, and other major cities adopted or are considering introducing tourist taxes. Fourthly, we will analyze how hotel industry reacts to the introduction of tourist tax, applying Olson's (1971, 1982) theory, and how each county in Florida and how different Japanese cities started enacting hotel taxes.

SOME BACKGROUND: HOTEL TAXES

For local CVBs, having a convention center and promoting their destination are often a dream as a means of increasing tourism revenues. However, securing stable funding for these activities related to events would pose fiscal challenges to local governments. Most CVBs receive vast majority of their funding from public sources. To reduce public funding to offset operating deficits at CVBs and public tourism infrastructures in the United States, most local CVBs have relied on tourist tax as their stable revenue source without creating burdens on local residents. In fact, hotel room tax revenue is by far the leading source of funding to CVBs, providing more than 87% of CVBs, according to the annual International Association of Convention & Visitor Bureaus (IACVB) member survey (IACVB, 2015).

Tourist tax has sometimes been opposed by the state hotel industry. For example, in 1993, the state of Colorado abolished government financing from its annual budget as voters repealed the 0.2% tourism tax (Bonham and Mak, 1996). Although Krohn and Uddin (1991) had noted that hotel and tourism taxes would be strongly supported by the tourism industry when the tax revenue was exclusively for the development and marketing of tourism, some of the CVBs are struggling with opposition from the hotel industry for introducing and continuing tourist taxes.

PURPOSE

The purpose of this paper is to provide tourism policy practitioners with the framework to design the tourist tax and its allocation, and hypotheses of how they can avoid, minimize and deal with possible local opposition to the tourist tax.

DESIGN/METHODOLOGY/APPROACH

This paper introduces cases from Florida and Japan with a focus on political processes and a geographical aspect. In order to analyze different CVBs funding through tourist tax, this paper uses the following classification frameworks: the level of the government and expenditure of tourist tax revenue.

(1) The level of the government

Theoretically, three levels of governmental and nongovernmental organizations can levy tourist tax in a country: Central (federal in the United States), regional (a state in the United States), and local municipal units such as county, city or town, or village.

(2) Tax revenue allocation

Within the government's budgeting system, there are broadly two types of revenue allocations: general purpose or tourism-related purpose.

With regard to tourism expenditure, it could be used for tourism development or tourism-related social policies. The tourism development includes constructing, expanding, and renewing convention centers, whereas tourism related social policy intends to compensate local governments for the expanded services demanded by their visitors (Kitchen and Slack 2003).

There is another way to categorize different types of tourism expenditure: geographic dependency. Geographically dependent expenditure means that the expenditure only contributes to a limited geographic area specifically.

FINDINGS

These US and Japanese narratives give us some hypotheses about how to deal with opposition to the tourist tax from the tourism industry.

Firstly, the tourism industry is more likely to support the tourism tax if

1. the revenue from the tourist tax is used for tourism-related purposes, instead of general purpose
2. the income is used for geographic dependent purposes such as building a convention center within their jurisdiction, and
3. the revenue is used for tourism development rather than tourism related social policy.

Secondly, regardless of the first point, the tourism industry in a particular city might oppose the tourist tax if the relative room rate of the hotel was excessive compared with other similar sites. If similar tourist destinations have a similar tourist tax it won't affect the influx of tourists to the city in question. For example, in Florida, the introduction of the tourism development

tax has spread from Hillsborough and Orange County to counties with similarly robust tourist industries, such as Miami-Dade and West Palm County. This happened despite these areas being quite far away from, geographically. However, less well-known counties can also impose the same tourist tax of places like Orange County because they are close in proximity.

Figure 1
COUNTIES INTRODUCED TOURIST DEVELOPMENT TAX PRIOR 1980

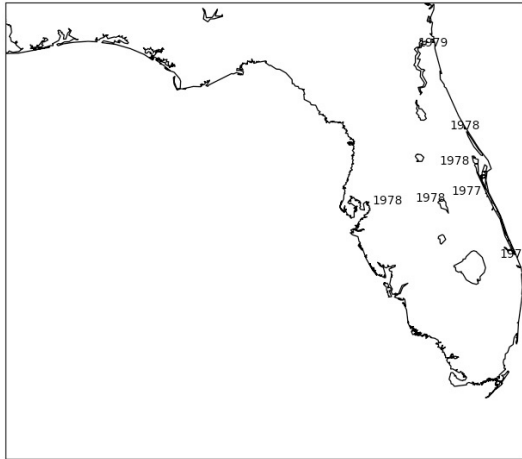

Figure 2
COUNTIES WITH THE TOURIST DEVELOPMENT TAX PRIOR TO 1985

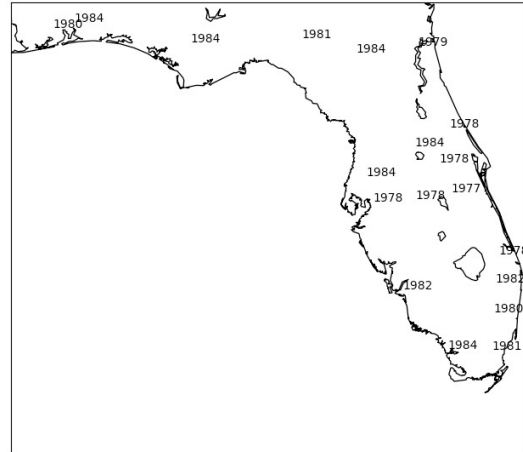

Figure 3
COUNTIES WITH THE TOURIST DEVELOPMENT TAX PRIOR TO 1990

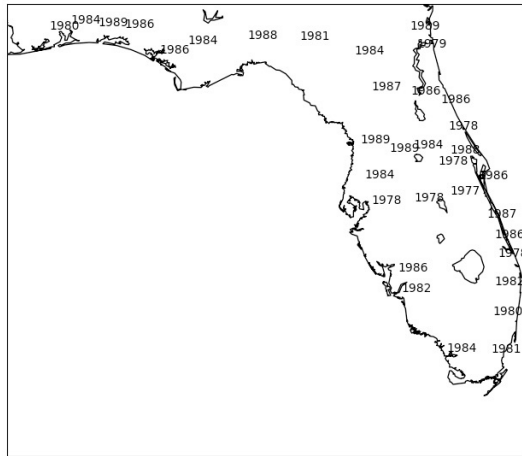
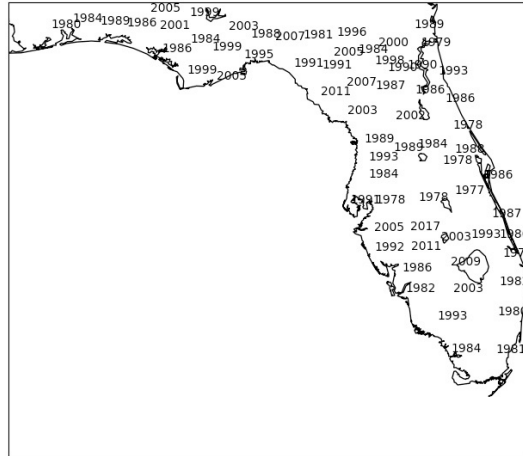
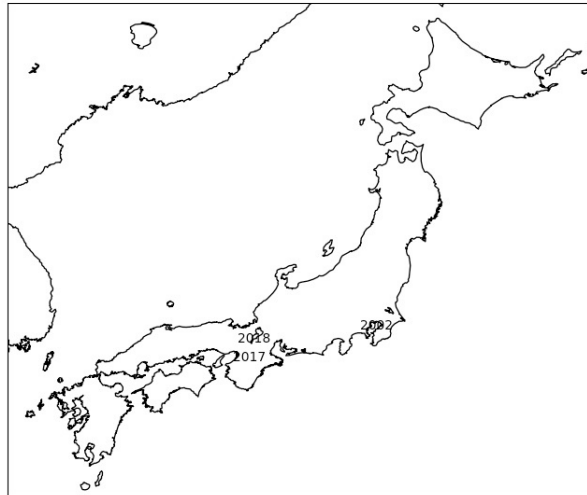

Figure 4
COUNTIES WITH THE TOURIST DEVELOPMENT TAX PRIOR TO 2017



In the case of Japan, Tokyo Metropolitan Government frequently argued that other major cities (New York, Paris, etc.) also had room tax, in order to convince legislators that it was a good idea to introduce this tax to Tokyo. In 2002 the tax was introduced to Tokyo and following this, Osaka began plans to introduce the tax. Osaka introduced this tax in 2017 and Kyoto should follow suit by 2018. Furthermore, other cities in Japan (with a smaller influx of tourists) are thinking about introducing this tax.

Figure 5
PREFECTURES AND CITIES IN JAPAN THAT INSTIGATED, (OR PLAN TO INSTIGATE) THE TOURIST TAX FROM 2002 ONWARDS.



These patterns could be explained by tax theories. In practice, the market contains externalities including tax competition (Avi-Yonah, 2000). The fact that the tourism development tax is spreading from Orange County and Hillsborough County to less known counties with regard to tourism, demonstrates the theory that smaller jurisdiction levies a lower tax rate (Bucovetsky, 1991). This theory is further demonstrated by Tokyo's decision to follow the tax policies of Paris and New York, and by having this decision emulated by Osaka and Kyoto

RESEARCH LIMITATIONS/IMPLICATIONS

This paper is a narrative case study of Florida and Japan, and it has limitations of external validity as such. This paper is intended for tourism professionals with practical frameworks of designing tourist tax and its allocation, and offers ideas as to how they can avoid, minimize and deal with possible local oppositions regarding the tourist room tax. Thus, further research is necessary to improve the validity of the frameworks and ideas.

PRACTICAL IMPLICATIONS

For tourism policy practitioners who intend to design the tourist tax to fund a convention center:

1. The tourist tax should be introduced in the smallest jurisdiction of the location of the proposed convention center because a convention center only contributes to a limited geographic area specifically.
2. The revenue from the tourist tax is restricted only for tourism-related purposes instead of general purposes
3. The revenue should be used exclusively for tourist development, such as funding public infrastructures for tourism (convention centers etc.) in order to avoid opposition from the tourism industry.

Governments can facilitate effective implementation of these conditions in their legislature as in the case of State of Florida Cities with a strong tourism industry might be able to increase their tourist taxes so that other cities with a less competitive tourism industry can introduce or increase tourist taxes.

ORIGINALITY/VALUE

The geographical analysis of the tourist tax gives us practical implications for practitioners. The frameworks of analyzing tourist tax and its revenue allocation gives us practical implications of how to design the tourist tax to fund a convention center, which is categorized as a geographically dependent expenditure. The introduction of Japanese narratives regarding hotel taxes might fuel the discussions of tourism tax in academia.

REFERENCES

Avi-Yonah R. S. 2000. "Globalization, Tax Competition, and the Fiscal Crisis of the Welfare State." *Harvard Law Review* 113:1575–1676.

Bucovetsky, S., 1991, Asymmetric tax competition, *Journal of Urban Economics* 30, 167- 181.

M.N. Gade, L.C. Adkins.(1990). Tax exporting and state revenue structures. *National Tax Journal*, 43 (1990), pp. 39-52

International Association of Convention & Visitor Bureaus. (2015). 2015 DMO ORGANIZATIONAL & FINANCIAL PROFILE STUDY

Krohn, F. B., and Z. Uddin (1991). "Anatomy of an Occupancy Tax: Failure by Omission . . .an Application to Regional Tourism." *Journal of Professional Services Marketing*, 7 (2): 183-90.

Nikkei Shimbun, October 8, 2017, "Sudden Emergence of Discussion on Accommodation Tax due to surge of inbound visitors" (in Japanese) "訪日客増えたから「宿泊税」各地でにわか導入機運"

A BOURDIEUSIAN CRITIQUE OF EVENT PROFESSIONALISATION

CAROLINE JACKSON

Bournemouth University, UK

PURPOSE

Traditional models of becoming an events professional have dominated the academic literature on the process of professionalisation. This paper uses Bourdieu's concepts to critique my understanding of the demand for and current position of the event professional. It particularly utilises Bourdieu's conceptualisation of 'field' to understand the agents and issues involved in this complex phenomenon. The focus is on the challenges of supporting a professionalisation agenda.

DESIGN/METHODOLOGY/APPROACH

This paper is based upon a theoretical discussion around the findings of an interpretive phenomenological study of 24 interviews undertaken across leaders from event companies, associations and education providers in the UK. The author is positioned across all three of these areas and uses Bourdieu's concepts of habitus, capital and field to explore the relationships and issues of adopting a traditional approach to professionalisation. The methodological approach is an important part of the discussion on the way that professionalisation is viewed and researched. The positivist approach preferred in practice is questioned but also utilized by Bourdieu to bridge the object-subject divide.

FINDINGS

The Professionalisation in Events research identified 4Ps – Policy, People and Professional Practice and that these blended together the 2Es – Experience and Education. The findings in this paper however are more discursive than definitive. The aim is to question but also to inform decisions on policy, practice and research that go beyond traditional and utilitarian approaches. For the first time it puts events and those involved in events into a socially constructed paradigm that explores the individual and organisational concerns of legitimacy, validity, recognition and reward.

RESEARCH LIMITATIONS/IMPLICATIONS

This study is part of an action research project that involves the researcher playing an active part in the review of policy and practice of event professionalisation within the event sector in the UK. Given the situated context of events in the UK the findings of this paper may not be directly applicable to other event fields. However, the approach may afford others a different lens through which to explore this and other event-related topics.

PRACTICAL IMPLICATIONS

The use of Bourdieu's work to critique the findings, to date, of the Professionalisation in Events research project offers a different perspective and alternative issues to discuss with practitioners and academics. It goes beyond the human capital arguments of individual recognition and reward to the organisational and socially constructed questions of a unified profession with clear structures, benchmarks and identity.

ORIGINALITY/VALUE

Using Bourdieu's concepts of habitus, capital and field offer a means of challenging and exploring the notion of professionalisation in the event sector. It also offers a different approach to researching event phenomena.

THE GESTALT OF EVENT CREATIVITY?

CAROLINE JACKSON

Bournemouth University, UK

JAMES MORGAN

Westminster University, UK

CHANTAL LAWS

Westminster University, UK

PURPOSE

This paper identifies the gestalt characteristics of creativity within outdoor events. It focuses on the creation and production of events and not on the event itself or the way that it is experienced. It is therefore interested in the processes and attributes of working in outdoor events, within various roles and responsibilities. The concept of gestalt helps to identify the defining features of a phenomenon that unfolds over a period of time.

DESIGN/METHODOLOGY/APPROACH

The Creativity in Events research project included a mixed-methods approach that identified the nature and understanding of outdoor events through interviewing 10 providers of different types of outdoor events. These were identified as cultural festivals, music festivals, outdoor sporting events, outdoor trade shows and outdoor corporate events. From these the salient characteristics of creativity were identified and transformed into a survey of people undertaking different job roles from Director to volunteer across the sector. Overall 233 useable questionnaires provided the data that was analysed to identify whether the outdoor event sector was creative and in what ways, across the different roles.

FINDINGS

This paper is an overall summary of the main characteristics identified through both the qualitative and quantitative stages of the research project. It approaches the results of these from an overarching meta-analysis based on gestalt principles. Six facets of event creativity were identified. These were: fluency, originality, imagination, elaboration, environment and complexity. The characteristics of divergent and convergent practices, alongside cognitive and affective features offered a complex but gestalt understanding of creativity in outdoor events. These featured collaboration across the creative event process; the creative familiarity offered by the necessity of compliance, and the necessity to be both pragmatic and creative.

RESEARCH LIMITATIONS/IMPLICATIONS

The gestalt concept itself recognizes that not all characteristics of a phenomenon, such as creativity, are constant and that there are highs and lows and potentially conflicting attributes. In attempting to identify and research the creativity of events results in a reduction and shaping of something quite messy and complex. Only in this way though can certain characteristics be recognised and further explored. Otherwise we just leave events as something that is only learnt through practice and experience.

PRACTICAL IMPLICATIONS

A better understanding of creativity in events is important for improving practice, education and research. The processes and practices developed and taught need to recognise both the divergent and convergent approaches. The work environment and collaborations are necessary to support the success of outdoor events.

ORIGINALITY/VALUE

Whilst the importance of creativity in the production of events has been recognized, there has been little research undertaken as to its characteristics. Creativity itself has predominantly been researched within the individual, with some emphasis on the organisation but very little on a whole sector.

FESTIVAL SUSTAINABILITY: A LONG-TERM HOLISTIC PERSPECTIVE

JUDITH MAIR

The University of Queensland, Australia

PURPOSE

This paper aims to present a new way to envisage sustainability. In the past, our ancestors were used to the idea that they would be involved in things that they would personally never see completed. The builders of the medieval cathedrals in Europe understood that they were working on something for future generations, and that the benefits of their labour would accrue to their descendants. In our modern fast-paced world, where we demand instant gratification, this notion has been lost. We look to products and services (including tourism and events) to meet our immediate needs, but we don't give enough thought to the long term implications of our short term demands.

DESIGN/METHODOLOGY/APPROACH

The paper draws on a case study of the Woodford Folk Festival in Queensland, Australia, which has a 500 year vision. Methods used include document analysis, interviews and participant observation.

FINDINGS

The findings demonstrate that where a festival organiser has a clear vision, even when this vision is radically different to the type of vision that most festivals produce, this can encourage and enthuse other stakeholders to become involved. The overall sustainability of the festival, and the site it occupies, revolves around this clearly articulated vision. The festival site is being replanted with native trees (over 100,000 to date) and this has brought benefits to native wildlife too. An important component of this is that the planting is done by festival-goers, as part of their commitment both to the festival and to the site, thus demonstrating buy-in from attendees. The festival has invested in an onsite wastewater treatment plant, and an onsite water filtration plant, and has created a visual arts studio and workshop for local and visiting artists. This shows that the festival is concerned not only with the natural environment, but also with the local and wider arts and music community. The festival also works closely with the local Indigenous community, the Jinibara Nation, and they are consulted on, and involved in, every decision the festival takes. Finally, the festival has a year-round volunteer program, allowing volunteers to maintain their connection with the festival and the site beyond the usual volunteer experience during a festival or event. These findings allow us to take a much longer term perspective on sustainability than is normal, and present a learning opportunity for other festivals.

RESEARCH LIMITATIONS/IMPLICATIONS

The paper is exploratory and qualitative in nature, therefore empirical testing would be needed to confirm its applicability to other festivals and events. It should also be noted that the findings of this paper reflect a festival which owns its own site and therefore some aspects of the findings cannot be easily translated to other festivals which simply hire a venue or site. Nonetheless, the findings of this paper allow us to begin to construct a different view of the concept of festival sustainability and longevity.

PRACTICAL IMPLICATIONS

The practical implications of this paper center around the fact that this festival is acting as a pioneer in the field of long term sustainability aspirations. Whilst other festivals may not want to take such an extended view of their sustainability, nonetheless, Woodford offers a range of potential lessons in sustainability for other festival organisers to learn from.

ORIGINALITY/VALUE

The paper is the first to examine how a 500 year vision can influence perspectives on sustainability as well as practical steps towards achieving this sustainable vision.

CARNIVAL EVENT EXPERIENCE IN BRAZIL

LENIA MARQUES

Universidade Aberta, Portugal

CARLA BORBA

Universidade Federal de Pernambuco, Brazil

PURPOSE

This paper aims to provide insights into the experience of Carnival in Brazil, using an events studies framework. There are studies on the practices of Carnival from a cultural studies perspective, and a few from an events management perspective. However, the experiential side of this popular event has yet to be understood. Carnival is a very popular event in the Brazil, and it's a moment where people can express creativity, even months ahead of the event, by, among others preparing their own costumes to wear during the celebrations. The present research aims at investigating the Carnival experience from a visitor's perspective, bringing insights on the importance of different elements of the individual experience.

DESIGN/METHODOLOGY/APPROACH

This paper uses a quantitative approach, drawn from the Event Experience Scale (EES) which was developed as a tool for measuring event experiences (Geus et al. 2015; Richards, 2017). The results are part of an ongoing study in which this tool has been used in different events in the UK, the Netherlands, Portugal, Spain, Mexico and Brazil. Data was collected with an online questionnaire, using the full scale in 2016, and the reduced scale in 2017. It was therefore a convenience sampling and snowball approach, and mainly use of social media for the research. In total, there were 600 complete responses, 250 for 2016, and 350 for 2017.

FINDINGS

Findings show that Carnival is a moment of high levels of excitement, and, overall, the results point out to a highly positive experience. From the findings it is also clear that participation of locals is an important factor and correlates significantly to a more positive experience.

Although Carnival participants are from all ages, most respondents are between 20 and 59 years. The respondents in both years are mostly from Brazil (over 98%), which is not surprising as it is a strong cultural festival. As compared to four other events, Carnival in Brazil has a strong identity emphasis (Richards, 2017). This also explains why the results point out to a high percentage of respondents being involved in the celebration year after year (67% for 2016 and 64% for 2017 answered that Carnival is part of their life since they could remember).

Although there's a high participation level, there are clearly different levels of involvement which also affect the experience in most dimensions. Probably due to a slightly change in the channels in collecting data, only in the 2017 data we can see two different groups which statistically different, with 68,67% answering they were actively art of a Carnival group ("bloco"). This means people from the group are going to be involved in pre-parties, social media groups, using the same t-shirt, having a reserved are, among other specificities. The fact of belonging to a "bloco" affects the overall experience, as respondents are more active and engaged emotionally, physically and cognitively.

Moreover, creative dimensions are systematically higher in the group of people belonging to a Carnival group. The two highest means in both groups relate to the appreciation of Carnival as a creative event (6.46 and 6.79 out of a 7 point Likert scale) and the active playfulness (with 6.50 and 6.16 out of 7). The difference between the groups in having new ideas and feeling creative is significant and it implies that creativity levels and creative outputs are more likely to be produced when people belong to a group.

RESEARCH LIMITATIONS/IMPLICATIONS

As data were mainly collected through social media, they should be interpreted bearing in mind that the sampling method may allow bias. The access of survey through social media possibly limits responses from high socio-economic class. Also it might be limited in terms of the lifestyle choices and range of age, as there are many people above 50 who are also involved in specific Carnival groups for over 30 years and who don't necessarily use social media.

PRACTICAL IMPLICATIONS:

As Finkel (2004) points out, and in line with the results, Carnival in Brazil does not match what the author calls "McFestivalisation", or "excessive sameness" (Leenders, van Telgen, Gemser, & Van der Wurff, 2005) of festivals since the consumer is co-creator of their own experience.

Event visitors, including the Carnival respondents, value their subjective experience, the ambience and feel of an event, more than the program offered (Kooistra, 2011).

The creative element is important, mainly the passive appreciation of creativity and playfulness, which can be worked at different levels when organising Carnival, for all audiences. As for the creative element, clearly there is space to develop products and appeal to developing Carnival experiences which have a more participatory activity – in a Carnival group – since this will increase the levels of creativity and creative feel, as well as the overall experience in all its dimensions.

There is also potential for development in terms of destination management, with high involvement of people in creative events, being not only a strong driver for attracting people to the location, but also an important element for identity.

In fact, creativity plays an important role in the involvement of the community as well as in the distinctive character of the event, which makes it specific in the destination.

In comparison with other events, Carnival in Brazil presents strong emotional dimensions, related for example with strong levels of excitement (Richards, 2017). This result in itself can be brought to attention in creating and optimising social and emotional capital.

For event organisers and policy makers, these results focused on the experience can potentially provide the platform for facilitating improved Carnival experiences as well as using these as assets in placemaking strategies.

Based on the results, paths for further development and quality of the Carnival experience can be highlighted, in a way that policy makers and other stakeholders can re-think ways to improve the event experience in a creativity framework.

ORIGINALITY/VALUE

Despite the fact that much has been written about Carnival, in particular in the field of Cultural Studies and Sociology, only a few studies have been focusing on the event itself, in particular from an experiential perspective. This paper bridges the gap in its insights on understanding Carnival as an event experience in its multiple dimensions.

REFERENCES

De Geus, S; Richards, G.; Toepoel, V. (2015). Conceptualisation and Operationalisation of Event and Festival Experiences: Creation of an event experience scale. *Scandinavian Journal of Hospitality and Tourism*, 16 (3), 274-296.

Finkel, R. (2004). McFestivalisation? The Roles of Combined Arts Festival in the UK Cultural Economy. Paper presented at the Journeys of Expression III: Tourism and Festivals as Transnational Practice, Innsbruck.

Kooistra, S. (2011, August 13). Festivalgangerwilintimiteit. *De Volkskrant*.

Leenders, M. A. A. M., van Telgen, J., Gemser, G., & Van der Wurff, R. (2005). Success in the Dutch music festival market: The role of format and content. *International Journal on Media Management*, 7(3-4), 148-157.

Richards, G.; Santana, A. (2017). Measuring event experiences: An international view. *Experiencias turísticas de festivales y eventos*. El Sauzal (Tenerife, Spain), PASOS, RTPC.

SCALE DEVELOPMENT TO MEASURE THE CO-CREATION EXPERIENCE, AND RESULTING VALUE IN ART EXHIBITIONS

ELAINE MATHIS

University of Central Florida, USA

MATHILDA VAN NIEKERK

University of Central Florida, USA

FEVZI OKUMUS

University of Central Florida, USA

MANUAL RIVERA

University of Central Florida, USA

INTRODUCTION

This study desires to test the relationships between event design, service design, co-creation, cognitive experience, affective experience, and value. In doing so, scales to measure co-creation and value will be created as so far no studies nor measurement models have been able to capture such complex constructs. The context of this study will be art exhibitions. Art exhibitions have the ability to break down barriers between art exhibition attendees and event designers so that the two actors may interact together and create something new, which results in added value.

PURPOSE

The purpose of this study is to develop and test a scale that can measure the co-creation experience and resulting value in an art exhibition. In doing so it can be ensured that all future researchers are utilizing the same scale in which to measure co-creation and assess the various impacts it may have in different contexts.

THEORETICAL FOUNDATION/LITERATURE REVIEW

The idea of co-creation is to “set free and combine the creative energies of many people, so that it transforms both their individual experience and the economics of the organization that enabled it,” (Gouillart, 2010; Mathis, 2013). The concept of co-creation stems from the service-dominant logic proposed by Vargo and Lusch (2007). As opposed to its counterpart goods-dominant logic, service-dominant logic is focused on the exchange of service. Under service-dominant logic, one service is exchanged for another service as actors contribute to the creation process by sharing knowledge and resources (Durugbo & Pawar, 2014). Through this interaction, a unique experience is developed, wherein a more beneficial product or service is made, and value is added since resources are shared by all involved willing resource integrating actors, here forth referred to as actors. Service-dominant logic embraces the ideals of experiences to involve all actors in the customization, personalization, and invention of new services (Durugbo & Pawar, 2014).

A challenge is that there is not one scale to measure the entire co-creation process and it has scarcely been applied to the events industry (Cova, Dali, & Zwick, 2011; Gronroos, 2011; Prahalad & Ramaswamy, 2004; Saarijarvi & Kuusela, 2013; Vargo & Lusch, 2007). The main point of holding an event is to create a platform for the co-creation of unique and memorable

experiences (Miettinen, Valtonen & Markuksela, 2015). To create this platform the event and service designs must be carefully planned and executed to provide all actors with the needed tools, access, and information to become immersed in the event experience.

RESEARCH METHODOLOGY

This study will be both qualitative and quantitative in nature and will utilize a two-phase approach (Creswell, 2007; Sirakaya-Turk & Uysal, 2011). As co-creation and value remain undefined, first a qualitative study will be used in order to better develop and define the constructs. In this method, a questionnaire may be developed. The questionnaire will lead into the quantitative portion of the study, where characteristics of co-creation within art exhibitions will be measured so that a scale measuring the co-creation experience within art exhibits may be created and tested.

The qualitative portion of the study consists of observations and interviews. One art exhibit was selected to observe how attendees were co-creating within the event. After the event, attendees were interviewed about their experience.

After the qualitative portion of the study, a survey will be created which will consist of measurement items derived from the interviews and observations. The survey will include questions focusing on event design, service design, co-creation, cognitive experience, affective experience, and value. While exact measurement items cannot be created until the qualitative study is conducted, it is thought that Likert-type scales will be best to capture these dimensions. This survey will be sent out to actors who attended art exhibitions in order to broaden the research sample from those who participated in the diaries and interviews. In doing so, a more representative sample of the population will be able to rate the event design, service design, their ability to co-create, and the outcomes experienced from participating in such an activity, including any value created.

EXPECTED FINDINGS

The data for the study has yet to be collected. It is expected that each hypothesis in this study will be significant and supported. Through the development of measurement models, it will be identified which attributes are needed to design an art exhibition to facilitate co-creation. It is believed the proper design will facilitate and encourage co-creation. In such a design, art exhibitions will become a platform for learning and creating unique experiences. It is predicted that the results of actor co-creation within art exhibitions will result in greater participation, creativity, performance, overall experience, and value. The implementation of co-creation within art exhibitions will help events move toward a more attendee-centered focus and put the attention on the quality of experiences, as it is in the experiences where value can be added (Axelsen & Arcodia, 2004).

By capturing the co-creation process, effects on the overall event experience can be studied so that the relationship is identified, though it is believed that this relationship will be a positive one. Measuring co-creation and the overall experience, will let researchers determine what are the outcomes of such efforts. As it is hypothesized that co-creation and positive experiences lead to enhanced value, this relationship can be tested and the types of resulting value can also be measured.

CONCLUSIONS & IMPLICATIONS

Having the proper event design will ensure that all actors have the needed tools and resources to interact with other actors and contribute their own ideas, which will enable co-creation. By identifying how to plan an art exhibition which embodies co-creation, many events and designers can restructure their experiences so that they can encourage co-creation by knowing how to structure events and invite actors into the co-creation process. As a result, the co-creation process can be applied more often and value will be added for all participating actors.

This study will provide a better understanding of the co-creation experience including what attendees need to co-create, how to design a platform for co-creation, and how attendees co-create during an art exhibition. This will be accomplished through the development of a scale to measure the co-creation experience and resulting value within art exhibitions, after a qualitative study, survey, and refinement of measurement models for the study constructs. By identifying the constructs to measure co-creation, cognitive experience, affective experience and value, the event design and service design may be planned to stimulate true co-creation, welcoming the interaction and input from all actors.

It is expected that enhanced value will be able to positively influence the event industry as better services, events, and other offerings will emerge. If people frequently request similar experiences, then these experiences can become standard and the needs of many will be met with a simple change in practice. Co-creation will change service encounters as actors will become aware of their vital role in the service delivery process, as well as know that they are welcome to come into the process to help shape their experiences through offering their own ideas and personal resources.

A STUDY OF THE EMOTIONS EXPERIENCED BY ATTENDEES AND NON-ATTENDEES: EVIDENCE FROM THE TOUR DE FRANCE

DARYL MAY

Sheffield Hallam University, UK

GRAHAM BERRIDGE

University of Surrey, UK

ELIZA KITCHEN

Leeds Beckett University, UK

GAVIN SULLIVAN

Coventry University, UK

Previous studies of impacts and experiences of sports events have largely focussed on the economic benefits to a region or city or the immediate feel good social factor. The study of other impacts is less prevalent but has recently begun to attract the attention of researchers with a number of studies looking at various socio-cultural impacts (Bull & Lovell, 2007). Whereas many tend to focus on either pre or post event data, others have begun to explore the immediately conscious or in-situ experience of attending an event. This paper contributes to this work by examining how spectator emotions vary over time considering the affective pre, during and post viewing and participation experience with reference to influence of context of attending or watching stages one and two of the 2014 Tour de France in Yorkshire.

The Tour de France is an annual sporting occasion and each year it alternatively traverses a clockwise or anticlockwise route through France. Unusually for a hallmark event it also has a history of partnerships with hosts outside of France (Berridge, 2012). For the 2014 version there were three stages in the UK. Two were held in Yorkshire and a third ran from Cambridge and finished in London. According to the post-event evaluation conducted by Leeds City Council and partners (2014), 3.5 million unique spectators watched the race over the three stages.

Specifically, in relation to the Tour de France there is a paucity of literature on social or cultural impacts. Referring to the after-effects or legacy of an event, Berridge (2012a) discussed image formation and policy impact (2012b) of the 2007 Tour de France. More recently Balduck, Maes and Buelens (2011) considered residents' perceptions both pre- and post-event by identifying the social impacts that predict residents' willingness to host the Tour de France in the future. In contrast, Leeds City Council and partners (2014) report on the impact of the 2014 event focusses upon economic benefit and legacy, although there is some mention of cultural contribution on the day in terms of artistic output.

The population for collecting data was spectators who had watched a stage of the Tour de France live either on the road side, in a spectator hub or on television. A self-completed questionnaire hosted on an on-line website was used to collect data. Self-completed questionnaires have been widely used to assess participant motivation to attend other general festival and event research (Getz, 2012) (see for example Nicholson and Pearce, 2011; Van Zyl and Botha, 2004; Kim et. al., 2010; Richards and Wilson, 2004) and in assessing sport based event spectators and fandom (for example Wann, 1995; Madrigal, 2003). A total of 188 respondents participated in the online questionnaire.

The PANAS scale (Merz et al., 2013) was used to collect information on the respondent's feelings before, during and after the race. This scale was used to measure the affective experience of the attendees, asking participants to indicate the degree to which they experienced each feeling on a scale of 1-5 with 5 being 'strongly agree'. Consistent with other studies, (de Carvalho et al., 2013), factor analysis was undertaken using Maximum Likelihood and Varimax rotation. The purpose of the factor analysis was to explore any clusters of emotions before, during and after the races.

The vast majority watched the event by the roadside with the highest positive value feelings of 'Interested, Excited and Enthusiastic' occurring during the live action. Negative feelings were more variable but a highest rating for 'Afraid' increased during the event, suggesting feelings of not wanting to miss anything (action). The paper indicates that further exploration of the emotions experienced before, during and after an event is required in order to more fully understand the complexity of the numerous factors that can influence this.

For those planning and staging such events it suggests that the regularity of occurrence should be a factor when designing component experiential moments and overall experience. In the case of cycling and similar multi-stage or multi-site events the mapping (route) and layout of the active spectator and participant arena can be carefully constructed to provide potential emotional hot spots.

REFERENCES

Balduck, A.-L., Meas, M., & Buelens, M. (2011). The social impact of the Tour de France: Comparisons of residents pre- and post-event perceptions. *European Sport Management Quarterly*, 11(2), 91-113.

Berridge, G. (2012). Event experience: a case study of differences between the way in which organizers plan an event experience and the way in which guests receive the experience. *Journal of Park and Recreation Administration*, 30(3), 7-23.

Berridge, G. (2012a). The promotion of cycling in London: The impact of the 2007 Tour de France Grand Depart on the image and provision of cycling in the capital. *Journal of Sport & Tourism*, 17(1), 43-61.

Berridge, G. (2012b). The impact of the 2007 Tour de France Grand Depart on cycling in London: a review of social and cultural legacy. In Bonham, J. & Lumb, P. *Australian Cycling Conference 2012 : Proceedings of the 4th Australian Cycling Conference RiAus, Adelaide 16-17 January 2012*. Australian Cycling Conference, Adelaide, 42-56.

Bull, C. J., & Lovell, J. (2007). The impact of hosting major sporting events on local residents: An analysis of the views and perceptions of Canterbury residents in relation to the Tour de France 2007. *Journal of Sport and Tourism*, 12(3-4), 229-248.

de Carvalho, H. W., Andreoli, S. B., Lara, D. R., Patrick, C. J., Quintana, M. I., Bressan, R. A., . . . Jorge, M. R. (2013). Structural validity and reliability of the Positive and Negative Affect Schedule (PANAS): Evidence from a large Brazilian community sample. *Revista Brasileira de Psiquiatria*, 35, 169-172.

Getz, D. (2005). *Event management and event tourism*, 2nd ed. New York : Cognizant Communication.

Kim, Y. G., Suh, B. W., & Eves, A. (2010) The relationships between food-related personality traits, satisfaction, and loyalty among visitors attending food events and festivals. *International Journal of Hospitality Management*, 29(2), 216-226.

Leeds City Council (2014). *Three Inspirational Days*.

Madrigal, R. (2003). Investigating an evolving leisure experience: Antecedents and consequences of spectator affect during a live sporting event. *Journal of Leisure Research*, 35(1), 23-48.

Merz, E. L., Malcarne, V. L., Roesch, S. C., Ko, C. M., Emerson, M., Roma, V. G., & Sadler, G. R. (2013). Psychometric properties of Positive and Negative Affect Schedule (PANAS) original and short forms in an African American community sample. *Journal of affective disorders*, 151(3), 942-949.

Nicholson, R. E., & Pearce, D. G. (2001). Why do people attend events: A comparative analysis of visitor motivations at four South Island events. *Journal of Travel Research*, 39(4), 449-460

Richards, G., & Wilson, J. (2004). The impact of cultural events on city image: Rotterdam, cultural capital of Europe 2001. *Urban studies*, 41(10), 1931-1951

Social Research Associates (2007) *The Tour de France- The Grand Depart 2007 Research Summary*. London: TFL.

Wann, D. L. (1995). Preliminary validation of the sport fan motivation scale. *Journal of Sport & Social Issues*, 19(4), 377-396.

Van Zyl, C. I. N. Á., & Botha, C. (2004). Motivational factors of local residents to attend the Aardklop National Arts Festival. *Event management*, 8(4), 213-222

FOSTERING COMMUNITY SUPPORT FOR MEGA EVENTS: A NARRATIVE INQUIRY OF SOCIAL IMPACTS EXPERIENCED AS A RESULT OF HOSTING THE FIFA 2010 WORLD CUP IN CAPE TOWN, SOUTH AFRICA

RUTENDO MUSIKAVANHU
Bournemouth University

PURPOSE

This paper uses some results from the author's PhD thesis and aims to explore, understand and interpret the social impacts experienced in Green Point, Cape Town during the FIFA 2010 World Cup; it provides knowledge on how the event influenced a legacy of community togetherness, and how community experiences from this event impact community support for mega events in this African society.

Mega events have become popular because of their universal appeal, grandiose nature and capacity to engender lasting legacies that offer the host community an opportunity to unite in celebration, generate international exposure and develop the locale (Roche, 2002). These reasons make hosting mega events appealing not only to developing countries beset with social issues (e.g. South Africa and the enduring effects of the apartheid era), but also to developed countries. Germany, for instance, through the FIFIA 2006 World Cup achieved positive social impacts that contributed to the lasting legacy of social unification and reimagining of the destination (Kersting, 2007). Thus, mega events have developed into one of the most significant discussions in festival studies (Maharaj, 2015).

Whilst social impacts can positively affect quality of life, mega events can also produce negative social impacts that result in overcrowding, marginalisation and gentrification (Preuss, 2015). For instance, Cooper (2012) found that gentrification during the London 2012 Olympics caused an increase in housing value, thus displacing lower-income community members. Therefore, negative social impacts can upset social wellbeing and result in the loss of community support through event criticism, protests and lack of community cooperation. Despite the possible negative effects, meaningful mega events remain effective vehicles that provide a festive atmosphere where positive social impacts can be realised, local cultures displayed, communities rebuilt and a sense of togetherness engendered; thus fostering community support for mega events.

This study aims to explore, interpret and understand community support for mega events in Green Point. In pursuit of this objective, this study recognises the host community's willingness to lend an event the uniqueness of their location and distinct way of life, as a form of community support (Collredo-Mansfeld, 2011). Gaining these unique features can help the event to distinguish itself from other events, and afford the event an occasion to showcase the uniqueness of the host community's way of life. Therefore, it is of importance to understand the nature of social impacts experienced in Green Point, exploring the extent to which a legacy of community togetherness was created, and the extent those experiences have affected community support of future mega events. The knowledge interpreted from this exploration is to provide the reader an experience-based perspective that communicates the significance of hosting the 2010 World Cup in Green Point, contributing an understanding to what happened, when it happened, where it happened, the characters involved and the objective of the action. The interpretive process provides meaningful insight towards understanding the social reality of the experience; contributing new understanding of community support.

DESIGN/METHODOLOGY/APPROACH

This study used narrative inquiry to explore and recapitulate people's lived experiences from the FIFA 2010 World Cup in Green Point. The approach follows the assemblies of qualitative methodology, and provided the researcher a different platform to access people's lived experiences, gaining unreserved access to their thoughts and outlooks. The sample composition consisted of 17 respondents based on purposive sampling. Green Point was the host community and its community members were the individuals most influenced by the social impacts of the event in the city of Cape Town. Narrative stories ordinarily yield rich data and therefore, this sample composition was enough to gain far-reaching stories. The researcher asked a single open-ended question following the unstructured nature of narratives stories, and did not interrupt because the goal was to listen to the story, with the exception of probing questions to encourage further conversation. This was to the benefit of the researcher because unsolicited information that was invaluable to this exploration was gathered.

FINDINGS

The findings in this study lend authority to the knowledge that mega events can be hosted by communities from developing nations toward achieving positive social impacts such as unity and communal pride; thus promising a lasting legacy of social restoration and togetherness. The knowledge uncovered is significant in revealing how the community of Green Point was bound together over the shared experience of the 2010 World Cup. Additionally, the effect of togetherness was observed to be a reduction in social resistance toward mega events, and instead, a perceived increase in community support for mega events.

RESEARCH LIMITATIONS/IMPLICATIONS

This study makes a methodological contribution to the exploration of community experiences of mega events through the use of narrative inquiry. This approach contributes storytelling as a means to sense making of social behaviour through the interpretation of community experiences. By gaining an understanding of community feelings and outlooks from stories attached to the experience of the FIFA World Cup in a developing nation, new interpretations that can contribute to a different understanding of mega events' social impacts and legacies have been generated. This provides an understanding of how community support might be fostered for future mega events. It is important to note that although the researcher would have liked to hear the stories of community members living across the entirety of Green Point, limitations in resources and time meant that only the experiences of a subset of the population could be collected.

PRACTICAL IMPLICATIONS

The task to identify the legacy effect from social impacts of mega events remains important to researchers, policy makers and practitioners because the ability to identify and interpret meaning in experiences of community members can contribute knowledge toward understanding how communities can be bound together over the experience of a mega event. Moreover, this knowledge can provide understanding to how social impacts affect community support for mega events.

ORIGINALITY/VALUE

This study shows that hosting worthy mega events in developing nations can result in a community that shares a communal sense of pride and togetherness. The findings reveal that effective mega events leave the host community motivated to support the hosting of additional mega events because of the positive social impacts experienced; thus upholding the idea that if hosted properly, the positive impacts and useful benefits such as social togetherness and willingness to host more mega events will be generated.

REFERENCES

Colloredo-Mansfeld, R. (2011). Work, cultural resources, and community commodities in the global economy. *Anthropology of Work Review*, 32(2), 51-62.

Cooper, J. (2012, July 1st). Price rise for 'affordable' housing puts Olympic legacy under threat. *The Independent*. Retrieved from: <http://www.independent.co.uk/> [Accessed 14th June 2017].

Kersting, N. (2007). Sport and national identity: A Comparison of the 2006 and 2010 FIFA World Cups. *Politikon*, 34(3), 277-293.

Maharaj, B. (2015). The turn of the south? Social and economic impacts of mega-events in India, Brazil and South Africa. *Local Economy*, 30(8), 983-999.

Preuss, H. (2015). A framework for identifying the legacies of a mega sport event. *Leisure Studies*, 34(6), 643-664.

Roche, M. (2002). *Mega events and modernity: Olympics and expos in the growth of global culture*. Routledge.

THE ECLECTIC ECONOMICS OF MUSIC FESTIVALS OCCURRING IN SMALL ISLAND DESTINATIONS

KELLY SEMRAD

University of Central Florida, USA

ROBERTICO CROES

University of Central Florida, USA

MANUEL RIVERA

University of Central Florida, USA

PURPOSE

The purpose of this study is to examine the economic benefits that a music festival may bring to a confined economy when observed within the theoretical lens of the eclectic economics paradigm and the internationalization theory by way of the OLI framework. Traditionally, the concepts of eclectic economics and the internationalization theory are applied within the context of manufacturing goods where corporations seek to determine if the manufacturing process will bring the firm comparative advantages pertaining to ownership, location, and internationalization (OLI framework) (Ferdinand and Williams, 2013). The framework is used to determine if it is best for a firm to produce a product itself or contract the production to a third party (Hill, 1999).

The eclectic economics paradigm, internationalization theory, and the OLI framework all function from the assumption that most businesses will avoid transactions in the open market when internal transactions carry lower costs and/or increased economic gains (Clark et al., 1997; Dunning, 2000). While it may be unusual to apply manufacturing frameworks to the tourism industry, a service industry with experience-based products (e.g. music festivals), the research will demonstrate that confined economies must also determine if the production of a tourism event will generate positive economic gains and whether those gains may be achieved via open market or internal transactions thus qualifying the use of the OLI framework.

DESIGN/METHODOLOGY/APPROACH

The Curaçao North Sea Jazz Festival (CNSJF)

This is a longitudinal survey case study that includes a five-year assessment (2010-2014) for the CNSJF. Curaçao is a small island located in the Caribbean. Over the last decade, the tourism industry's growth has stagnated and its continued contribution to the wider economy has become a growing concern to Curaçao government officials. Therefore, activities that increase foreign exchange earnings through ownership, location, and internationalization (OLI) are desired opportunities to increase economic growth on the island. The CNSJF is considered one such opportunity.

The O-advantages are measured through income bearing activities such as total international tourist arrivals and the share of repeat attendees to the festival. The Ladvantages are measured by the destination's production of the festival and the attendees' consumption of tourism related products so that tourists may attend the CNSJF. The attendees' length of stay and purpose of travel to Curaçao constitutes this measurement. The I-advantages are measured by inward and outward movements. Inward movements

are analyzed through the backward economic linkages and indirect economic impact; whereas the outward movements are assessed through the forward economic linkages and direct economic impact.

An I-O Model was used to capture the internationalization benefits of the CNSJF for Curaçao. The I-O model was provided by the Curaçao Bureau of Statistics and consists of an 11x11 matrix based on the 2008 National Accounts. The foundational notation of the I-O model used follows Miller and Blair (1985 p. 102) and is expressed as $X = (I - A)^{-1} Y$. Where Y represents the final demand; A is a square matrix defining the relations of production; and $(I - A)^{-1}$ is the Leontief inverse matrix. The I-O model provides multipliers that may be used as the first step to quantify the effects of demand change that may influence the internationalization benefits for a destination.

The Leontief multipliers are the first set of multipliers and reveal backward linkages within the economy that reflect partial economic activities (i.e., purchases from one sector to that of others) and the potential for inward internationalization movement. The backward linkage multiplier follows Cai et al., (2006) and will be denoted as BL and is given by $BL_i = 1 + e'(I - A_{ij})^{-1} A_{ji}$, where 1 represents the initial unit output change in industry i , while e is a sub vector that aggregates the elements of ΔX_j . In order to compare the BL s across industries a BL index is referenced. The corresponding BL index is calculated by dividing the Leontief multiplier by the average multiplier for all industries and is expressed as $BL_i / \sum_k BL_k / k$.

Because the Leontief multipliers are grounded on demand pull considerations they are not able to capture the forward linkages (FL s). Therefore, the study also applied the Ghosh model to calculate the FL s as a form of the potential outward movement of internationalization. The FL s are the economic transactions that occur between the vendors and the CNSJF attendees. As suggested by Cai et al., (2006) the Ghosh forward multiplier was used and is given by $FL_i = 1 + B_{ij} (I - B_{ij})^{-1} e$. The corresponding FL index is calculated by dividing the Ghosh multiplier by the average Ghosh multiplier and is expressed as $FL_i / \sum_k FL_k / k$.

These multipliers and indices will measure the absolute and relative strength of the BL s and FL s vis-à-vis other industries.

FINDINGS

A total of 1,940 CNSJF attendees completed the participant intercept survey from 2010-2014. The study found that the CNSJF sufficed the three main comparative advantage factors observed within the eclectic economics paradigm. The O-advantages captured a relative position of the potential internationalization benefits for the destination, the Ladvantages conferred Curaçao's internationalization strength by examining the consumption, duration, and the longitudinal vitality of repeat CNSJF attendees to the island.

Traditionally, I-advantages are recognized when the product is consumed on a global scale. Curaçao's I-advantages from the CNSJF come through the global distribution and consumption of the destination's offerings via international arrivals and foreign exchange earnings. Overall, the outward movement provided an initial I-advantage for Curaçao, but the inward movement I-advantage was a result of the dynamics between the sectors and the island's use of linkages. Both movements demonstrated a positive economic gain for the island.

RESEARCH LIMITATIONS/IMPLICATIONS

The study reveals two main limitations. The OLI Framework and the I-O technique are static in nature. Therefore, it is difficult to detect the dynamic evolution of the music festival as well how that evolution impacts the destination. In addition, the economic impact of the CNSJF stems from the specific configuration of the political and social factors present in Curaçao.

PRACTICAL IMPLICATIONS

When considering that Curaçao is a confined economy, the prospective ability for Curaçao to render the benefits of I-advantages involves sustaining the O and Ladvantages. It is important to note that in order for a destination to capture the Iadvantages, the O and L-advantages must be sustained and functional in order to initiate an outward movement that would then trigger the consequential positive inward movement. Thus, it seems imperative that the destination management organization efficiently craft complementary products that allow for the cohesive function of the OLIadvantages.

ORIGINALITY/VALUE

A primary contribution of this study is the objective measurement of the OLI Framework. Traditionally, OLI-advantages are measured subjectively by managers' perceptions (Dunning, 2000). This study evaluates the actual performance of the OLI-advantages.

REFERENCES

- Cai, J., Leung, P. and Mak, J. (2006). Tourism's forward and backward linkages. *Journal of Travel Research*, 45(1), 36-52.
- Dunning, J. (2000). The eclectic paradigm as an envelope for economic and business theories of MNE activity. *International Business Review*, 9(1), 163-190.
- Ferdinand, N. and Williams, N. (2013). International festivals as experience production systems. *Tourism Management*, 34(1), 202-210.
- Hill, C. (1999). *International business: Competing in the global marketplace*, (6th ed.) McGraw-Hill/Irwin, New York.
- Clark, C., Pugh, D., and Mallory, G. (1997). The process of internationalization in the operating firm. *International Business Review*, 6(6), 605-623.

THE ROLE OF SOCIAL INFLUENCE ON EXPO ATTENDEE BEHAVIOR UTILIZING VIDEO TRACKING

ERIC OLSON

Iowa State University, USA

PURPOSE

An exhibition/expo/tradeshow is a special event that brings together buyers (who have a specific need or want to be fulfilled) and sellers (of products and services). Social influence, how consumer behavior is impacted by others (Latane, 1981), lays a vital role in the information exchange process between trade show exhibitors and exhibitor attendees. For example, front-line exhibitors can be trained and motivated to interact, provide information, and consult with exhibitor attendees in order to increase the likeliness of the attendee being engaged with the product and service that is being displayed, with the ultimate goal of purchasing the product/service. Additionally, exhibitors may be able to control the social and expo environment itself (Lam, 2001) in order to impact exhibitor attendee's behavior. While social influence has been heavily examined in the retail industry (e.g. Argo, Dahl, & Manchanda, 2005), the role of social influence has not been examined in the exhibition industry. Furthermore, the interactions between buyers and sellers in an expo environment is an under researched area.

The aim of this research is to examine the role of social influence on exhibitor attendee behavior utilizing video tracking technology. Specifically, this study examined the role of touch frequency, crowding, talk frequency, and motivation on expo attendees' likeliness of favorable responses to an exhibitor.

DESIGN/METHODOLOGY/APPROACH

We suggest that an exhibitor attendee's likeliness of favorable responses will increase as (a) the number of touch points during the interaction increases; (b) the number of other attendees at the exhibit increases, (c) the length of the interaction between exhibitor and attendee increases, and (d) the speed the exhibitor attendee arrives to the exhibitor. In this study, the following variables were identified and monitored, since previous research has suggested that these variables can impact the social influence of exhibitor attendees (Zhang, Li, Raymond, & Leykin, 2014).

Table 1
TABLE OF VARIABLES EXAMINED IN THIS STUDY

Variable	Definition
Touch Frequency	Number of touch points (i.e. handshake) between exhibitor and exhibitor attendee
Crowding	Number of exhibitor attendees at the exhibitor booth
Talk Frequency	Length of discussion between exhibitor and attendee
Motivation	Speed which exhibitor attendee arrives exhibitor booth
Likeliness of Favorable Responses	Number of times exhibitor attendee leaves with promotion brochure, business card, leaves contact information

Note: Variable definitions from Zhang et al., (2014)

This study employed panoramic video technology to capture real-life interaction between a front-line exhibitor and an exhibitor attendee at consumer expo in the Midwest U.S. Specifically, the video captured the movement of the exhibitor attendee, the interaction between the exhibitor employees and attendee, and other variables in the exhibitor space

environment of one regional employer. The video camera was installed at an adjoining expo booth. Data was coded utilizing video tracking software based by two independently trained researchers. For example, for talk frequency, coders evaluated the number of times there was a handshake between the two parties. For crowding, the number of attendees was counted during the interaction between the attendee and the expo booth representative. Talk frequency was coded as the length of interaction and discussion between the exhibitor and the attendee. Motivation was coded as the speed at which the attendee arrived at the exhibitor booth (fast, medium, or slow). Likelihood of favorable responses was coded as a yes/no responses with yes indicating the attendee picked up a business card or promotional/marketing brochure or touched/interacted with the product at the display booth.

FINDINGS

During the four-hour exhibit, 109 interactions were observed, ranging from 1:30 minutes to 12:45 minutes. A logistic regression analysis was conducted to predict likelihood of favorable response with the four independent variables touch frequency, crowding, talk frequency, and motivation as predictors. A test of the full model was significant, indicating that the predictors as a set of reliable distinguished factors ($\chi^2 = 22.92$, $p < 0.0021$ with $df = 2$). R^2 of 0.421 indicated a relationship between prediction and group. Prediction success overall was 90%, and the Wald criterion demonstrated touch frequency ($p < 0.001$), crowding ($p < 0.001$), and talk frequency ($p = .014$) made a significant contribution of prediction. Motivation was not significant. Exp(B) values indicated that when touch frequency was raised by one unit (one handshake) the odds ratio is five times as large; when crowding was raised by one unit (one additional person) the odds ratio is three times as large; and when talk frequency was raised by one unit (30 seconds of talking) the odds ratio is twice as large.

RESEARCH LIMITATIONS/IMPLICATIONS

Although these initial findings are interesting, future research could also use experimental design to confirm findings by focusing on specific variables in the cause and effect relationship of the exhibitor and attendee relationship. Additionally, this study only focused on the previously discussed variables of touch frequency, crowding, talk frequency, and motivation; since additional environmental and external variables are embedded in an actual expo environment (e.g., product category, additional people in the environment, music, attractiveness of company employees, and day/time of the expo), future studies should be employed to examine how differing external variables impact expo interactions.

PRACTICAL IMPLICATIONS

For exhibitors, this study provides specific tactics for front-line exhibitors and the environment they operate in and provide insight to improve sales conversion rates, such as through the use of promotion, display, and interaction. Results suggest exhibitors can place a higher need on touch frequency (such as a handshake) to increase intentions, such as promoting the taking of a business card or product literature. Since favorable intentions increased when crowding occurs, exhibitors can attempt to increase more people at a booth or engage in small group discussion so others walking by may be impacted by the crowding impact (Argo, Dahl, & Manchanda, 2005). Findings also suggest that they are behavioral clues that an exhibitor can use to identify an exhibitor's higher need state and be more responsiveness to the discussion of the exhibitor's product.

ORIGINALITY/VALUE

The originality/value of this research is threefold. First, this study contributed to social interaction theory. Second, this study provides tactics and suggestions for businesses that use expos to enhance their marketing and sales initiatives. This research is original in utilizing a unique methodological contribution by using video technology to examine the underlying mechanisms of interactions at expo booths.

REFERENCES

- Argo, Jennifer, J., Dahl, D. W., & Manchanda, V. (2005). The influence of a mere social presence in a retail context. *Journal of Consumer Research*, 32(2), 207-212.
- Lam, S., Vandenbosch, M., Hulland, J., & Pearce, M. (2001). Evaluating promotions in shopping environments. *Marketing Science*, 20(2), 194-215.
- Latane, B. (1981). The psychology of social impact. *American Psychologist*, 36(4), 343-356.
- Zhang, X., Raymond, W. L., Burke, R. R., & Leykin, A. (2014). An examination of social influence on shopping behavior using video tracking data. *Journal of Marketing*, 78, 24-41.

A LONGITUDINAL STUDY OF THE LONG-TERM EVENTS IMPACTS FOR WEYMOUTH UK FROM HOSTING EVENTS FOR LONDON 2012

DEBBIE SADD

Bournemouth University, UK

Mega-events, include sporting events which are held on either a regular or one-off basis that have become a key tool in the tourism marketing strategies at international, national and regional levels through their primary function of providing tourism opportunities (Hall, 1992). Moreover, Smith (2009) recognized that the hosting of international events promotes esteem, allowing local people to display their skills, cultural attitudes and civic pride. These events are also extremely significant as “they may leave behind legacies which will impact on the host community far more widely than the immediate period in which the event actually took place” (Hall, 1992, p1).

This research project in a long-term study over 14 years of the social impacts of the hosting of events as part of London 2012 at a venue, 140 miles from London, Weymouth and Portland, Dorset. The original research was carried out in 2003, 8 years before the hosting, with the second data collection in 2017 (5 years after the event).

It was on the 6th July 2005 that the towns of Weymouth and Portland, Dorset heard that in 7 years’ time they would be hosting the sailing for the successful London 2012 Olympic Bid, although planning for this outcome had begun a few years previously. Sadd and Jackson (2006) wrote about the resident views prior to the Games taking place noting their fears and concerns.

Furthermore, Sadd (2008) wrote about Weymouth’s once in a lifetime opportunity from the hosting including the global exposure and chance to relaunch the areas identity, yet the research is showing little has changed, especially within the town itself. Many plans were suggested about developments including the Pavilion Peninsula and also the redevelopment of the waterfront esplanade, but it would appear that the town is somewhat indecisive as to whether they have benefited from the hosting of the sailing events for the main Games and the Paralympic Games. Furthermore, there are tensions about how it wants to position itself with regard to attracting visitors and income to the town.

The original research carried out in Weymouth during the summer of 2003 indicates that the local resident’s saw the most positive impact of tourism being the additional income it would bring to the town followed by reducing unemployment and then increasing awareness of the town and area. The residents only rated “improving infrastructure” as fourth out of five. However, from the point of view of negative impacts, the worst impact was the increase in prices seen in everything from housing to public amenities and general cost of living. Increases in pollution and crime levels were also cited as negative impacts by almost a fifth of the respondents. The second data set clearly shows that little has been done to improve facilities beyond those for the sailing community. A key theme emerging is around this:

The council lack a vision of any description in that they curtail any good suggestions e.g. green housing, festivals, need more sporting events,
Town is desperate for regeneration and improved facilities it lags well behind other towns and it needs to look to the future and not delve into a bygone era.
Having travelled more around the southwest recently, I am staggered at how poor the conditions are in Weymouth

The area is lovely but let own by the local council

Further in-depth analysis of the Weymouth Residents indicated in 2003 that 92.4% of respondents believed Government money, whether central or local, should fund improvements to the town's infrastructure as opposed to private funding, yet 88.6% have never been consulted on tourism developments, which is an interesting result as they are all members of the council's citizens panel. A further statistic of 82.1% of respondents do not feel that the views of the public were considered in tourism development, despite the presence of public consultation forums and the local community partnership. Some residents felt that the council places the wishes and needs of the tourists above those of the residents. In comparison, the second data set collected in 2017, shows that whilst there were strong indicators of improvements, the town still suffers from an identity and tries to cater to all sectors of the tourism market. Furthermore, a lot of investment has been placed into facilities for this limited market sector and not for the locals as it been invested in sporting facilities, although these are viewed as elitist and not for all sectors of society.

More consultation needed on plans when events take place, needs more events facilities such as a central entertainment venue such as a theatre.

Urgent action need to address the empty shops in the town centre why not have pop up art galleries

However, whilst the original research had a response rate of over 400, this second data set is small (n=107) as the citizens panel no longer exists and therefore to try and match the data set as near as possible, a door step delivery was made within the post codes form the original survey responses to match the geographical spread.

The statistical data is still being analyzed in comparison to the first data set and will be presented at the conference. However, it is the qualitative comments that are proving very interesting considering the original promises and vision for the area. When using thematic analysis and looking at global themes emerging are; the lack of vision from the council; poor transport management; conflicts between need for tourist and local impacts on residents ; Council not trusted to take any notice of local feelings.

Finally, in relation to the specific hosting of the Olympics, the responses are very disappointing;

Feel the Olympic have not helped/ not left anything for Weymouth and Portland

During the Olympics, the locals were encouraged to stay away with adverts saying town was going to be busy, the town was empty, second week better

Leading up to the Olympics the council seemed on the FastTrack however all improvements have slowed to a top now.

In conclusion, despite promises made and opportunities offered by the hosting of the sailing competitions, the town has not benefited in the ways expressed by the residents.

REFERENCES

Hall, C.M. (1992). Hallmark Tourist Events; Impacts, Management and Planning. London; Bellhaven Press

Sadd, D. (2008). Weymouth's once in a lifetime opportunity. In J. Ali-Knight, M. Robertson, A. Fyall, & A. Ladkin (Eds.), *International Perspectives of Festivals and Events: Paradigms of Analysis* (pp. 21-40). London: Elsevier.

Sadd, D., & Jackson, C. (2006). Planning for Resort Regeneration: The role of the Olympic 2012 bid for Weymouth and Portland, Dorset. In M. Robertson (Ed.), *Sporting Events and Event Tourism: Impacts, Plans and Opportunities* (pp. 43-64). University of Brighton, England: Leisure Studies Association.

Smith, A. (2009). Theorising the Relationship between Major Sport Events and Social Sustainability, *Journal of Sport & Tourism*, 14:2-3, 109-120

DO MEGA EVENTS CAUSE CHANGE IN COUNTY OR DESTINATION IMAGE? THE CASE OF 2016 OLYMPIC GAMES IN BRAZIL

ASLI TASCI

University of Central Florida, USA

JEEYEON HAHM

University of Central Florida, USA

DEBORAH BREITER-TERRY

University of Central Florida, USA

BACKGROUND OF THE STUDY

Over the years, destinations have recognized the fact that hosting an event promotes tourism development and change in tourists' perceived image of a destination (Getz, 2008; Jaffe & Nebenzahl, 1993; Kim & Morrison, 2005; Lee, Lee, & Lee, 2005; Xing & Chalip, 2006). Gartner (1993), in his comprehensive destination image formation framework, found that when a destination hosts an event, the destination image will change because of many related factors, such as media exposure, word of mouth, and so on. The Olympics or the FIFA World Cup are strong brands where the image of the event is known to transfer to destination image (Kotler & Gertner, 2002). These mega sports events bring significant media attention to the host countries. Understanding the massive and primarily positive impact of hosting a mega sports event on the country in terms of increasing awareness and visitation, host countries aim destination branding by developing associations with the event image (Kim, Kang, & Kim, 2014; Ritchie, 1984). Several studies have found a positive influence of mega sports events on destination image and visit intention (e.g., Kaplanidou & Gibson, 2010; Kaplanidou & Vogt, 2007). After hosting the 2006 FIFA World Cup, the German National Tourist Board confirmed that Germany successfully capitalized on the opportunity presented by the mega sports event to enhance its image (as cited in Florek & Insch, 2011). Also, football supporters from New Zealand showed a more favorable overall evaluation of Germany after the World Cup (Florek, Breitbarth, & Conejo, 2008). On the other hand, there are studies that found negative, mixed, or even no effects of hosting a mega sports event on destination image (e.g., Gallarza, Saura, & Garcí a, 2002; Kim, Gursoy, & Lee, 2006). Some studies reported negative externalities (e.g., traffic congestion, environmental damage) and mismanagement of the event, lack of adequate media management when there was negative publicity regarding the event, lack of interest and support from the media and event organizers in destination promotion, and the discrepancy between the event image and destination image (Getz & Fairley, 2003; Xing & Chalip, 2006). According to Gwinner and Eaton (1999), image transfer theory suggests a two-way transfer; meaning images of an event transfer to the destination image and at the same time, the event image can get enhanced or modified because of destination image. Therefore, the destination and the event may benefit from each other (Florek & Insch, 2011).

In cases where there is negative media coverage before or during a mega event, the image transfer on both the mega event and the destination may be in an undesirable direction. For example, the negative media coverage of Brazil due to several environmental and political issues that surfaced just before the Olympics might have caused a negative image for the event itself and the country, contrary to what is expected under normal conditions. The current study measures the change in image of both a mega event and the host destination, using the unique opportunity presented by the 2016 Olympic Games in Brazil.

METHODOLOGY

To test the study hypotheses, a longitudinal survey design was conducted with four groups of respondent in an online platform. A structured survey was designed on Qualtrics. The survey items included 7-point Likert scales (1=Extremely Poor, 7= Excellent) measuring country image (9 items), destination image (13 items), and Olympics image (10 items). Besides, 7-point importance scales (1=Extremely unimportant, 7=Extremely important) were used to measure the importance of information sources for destination image (6 items); the same scale was also used to measure the importance of information sources for the Olympics image (6 items). Also, questions regarding the past experience with the country and the Olympics, familiarity with and interest in the Olympics were also included along with the common sociodemographic questions in the end (gender, age, education level, marital status, residence state, annual income, and race).

A random sample was acquired from Amazon's Mechanical Turk (MTurk), an Internet survey marketplace of voluntary survey takers. In order to identify the change in interrelations among the Olympics image, destination image, and country image, the same questionnaire was administered in four different times, 1 month before the games (n=101), 1 month after the games (n=94), and 5 months after the games (n=98). One-way ANOVA tools of SPSS 23 were used to analyze the data.

Table 1
COMPARISON OF COUNTY IMAGE, DESTINATION IMAGE AND OLYMPIC GAMES
IMAGE FOR DIFFERENT GROUPS IN DIFFERENT TIMES OF MEASURE

Image Items	1 month before (n=101)	1 month after (n=94)	5 months after (n=98)	One-way ANOVA Test significan
Country Image				
Economic development	3.42	3.70	3.42	.183
Technological development	3.86	3.89	3.40	.006
Educational system	3.44	3.44	3.18	.254
Political stability	3.35	3.53	3.32	.442
Production of high quality products	3.61	3.78	3.26	.011
Standard of living	3.20	3.34	3.13	.544
Attention to societal well-being	3.01	3.32	3.33	.193
Diversity of cultural makeup	4.58	4.49	4.38	.577
Environmental awareness	3.38	3.47	3.14	.264
Destination Image				
Variety of natural attractions	5.03	5.06	4.93	.704
Scenic beauty	5.88	6.02	5.79	.192
Beaches/water attractions	5.60	5.67	5.53	.736
Amount of cultural/heritage attractions	5.44	5.43	5.49	.888
Variety of outdoor activities	5.65	5.65	5.62	.973
Weather conditions	5.34	5.43	5.53	.410
People's friendliness/hospitality	4.89	4.52	4.80	.077
Uniqueness of culture/customs	5.35	5.06	5.33	.153
Nightlife and entertainment opportunities	5.32	5.39	5.43	.795
Quality of accommodation facilities and services	4.48	4.70	4.47	.310
Quality of eatery facilities and services	4.59	4.73	4.62	.679
Value for money	4.66	4.46	4.60	.439
Olympic Games Image				
Attractiveness of the host destinations	4.87	5.23	5.19	.051
Overall quality of Olympic venues (e.g., arenas, stadiums, fields)	5.15	5.44	5.26	.203
Spectacle of ceremonies	5.51	5.47	5.69	.303
Overall contribution to the image of the destination	4.88	5.28	5.09	.071
Prestige of the Olympic Games	5.52	5.67	5.56	.664
Reflection of host culture in the Olympics	4.84	5.23	5.19	.035
Inclusiveness of all sports	5.08	5.19	5.22	.679
Equal opportunity for diverse athletes	5.46	5.49	5.56	.844
Contribution of the Olympic Games to social, cultural, and educational values	4.81	5.22	5.06	.097
Environmentally friendly practices of the Olympic Games	4.37	4.60	4.42	.542

RESULTS

Results in Table 1 showed that the country image, destination image and the event image remained stable until after the 5 months of the Olympic Games organization took place in Brazil. There are changes in two items of country image and one item of the event image that seemed anomaly rather than a pattern of change.

IMPLICATIONS

The results of this study imply that image in country, destination and event context is resistant to change in the short term up to 5 months. Further measures are needed in longer time frames in order to see where image change with a pattern is observed. For this reason, one more measure will be conducted at the 11-month interval in order to see if perceivable change exists. The results of this last measure will be presented at the conference along with implications.

REFERENCES

- Getz, D. (2008). Event tourism: Definition, evolution, and research. *Tourism Management*, 29(3), 403-428.
- Jaffe, E. D. & Nebenzahl, I. D. (1993). Global promotion of country image: Do the Olympics count? In Papadopoulos, N. & Heslop, L. A. (Eds.). *Product country images: Impact and role in international marketing* (pp. 433-452). New York: International Business Press.
- Kim, S. S. & Morrison, A. M. (2005). Change of images of South Korea among foreign tourists after the 2002 FIFA World Cup. *Tourism Management*, 26(2), 233-247.
- Lee, C.-K., Lee, Y.-K. & Lee, B. (2005). Korea's destination image formed by the 2002 World Cup. *Annals of Tourism Research*, 32(4), 839-858.
- Kotler, P., & Gertner, D. (2002). Country as brand, product, and beyond: A place marketing and brand management perspective. *Journal of Brand Management*, 9(4), 249-261.
- Kim, J., Kang, J. H., & Kim, Y. (2014). Impact of mega sport events on destination image and country image. *Sport Marketing Quarterly*, 23(3), 161-175.
- Ritchie, J. R. B. (1984). Assessing the impact of hallmark events: Conceptual and research issues. *Journal of Travel Research*, 23(1), 2-11.
- Kaplanidou, K. & Gibson, H. J. (2010). Predicting behavioral intentions of active event sport tourists: The case of a small-scale recurring sports event. *Journal of Sport & Tourism*, 15(2), 163-179.
- Kaplanidou, K., & Vogt, C. (2007). The Interrelationship between sport event and destination image and sport tourists' behaviours. *Journal of Sport & Tourism*, 12(3-4), 183-206.
- Florek, M. & Insch, A. (2011). When fit matters: Leveraging destination and event image congruence. *Journal of Hospitality Marketing & Management*, 20(3-4), 265-286.

Florek, M., Breitbarth, T., & Conejo, F. (2008). Mega event = mega impact? Traveling fans' experience and perceptions of the 2006 FIFA World Cup host nation. *Journal of Sport & Tourism*, 13, 199-219.

Gallarza, M. G., Saura, I. G., & Garcí a, H. C. (2002). Destination image: Towards a conceptual framework. *Annals of Tourism Research*, 29(1), 56-78.

Kim, H. J., Gursoy, D., & Lee, S.-B. (2006). The impact of the 2002 World Cup on South Korea: comparisons of pre- and post-games. *Tourism Management*, 27(1), 86-96.

Getz, D. & Fairley, S. (2003). Media management at sport events for destination promotion: Case studies and concepts. *Event Management*, 8, 127-139.

Gwinner, K. & Eaton, J. (1999). Building brand image through event sponsorship: The role of image transfer. *Journal of Advertising*, 28(4), 47-57.

Xing, X., & Chalip, L. (2006). Effects of hosting a sport event on destination brand: a test of co-branding and match-up models. *Sport Management Review*, 9(1), 49-78.

Full papers

DEVELOPING LEADERS FOR A COLLABORATIVE WORKFORCE: THE CHALLENGE FOR EVENT MANAGEMENT TRAINING IN HIGHER EDUCATION

LAURIE BAKER-MALUNGU

Institute for Tourism Studies, Macao

ABSTRACT

Although the employability of event organisers rest upon one's demonstrated ability to collaborate effectively as a member of a team, apply professional knowledge and skills honed through experience and display good communication and effective interpersonal skills, event managers must also possess advanced problem solving skills, consider creative and innovative ways to realise an event and demonstrate a degree of confidence that emits capacity. Undergraduate event management training programmes have developed pedagogic approaches that provide students with the knowledge, skills and competence in practice to successfully enter the industry upon graduation. There may, however, be limited opportunities for ambitious students to demonstrate qualities associated with industry leadership during the four years of higher education (HE). This exploratory case study considered the potential for a senior research dissertation requirement to enable students to co-create a learning experience worthy of demonstrating their leadership capacity. Through a qualitative approach which utilised content analysis of the thesis/project titles selected by event management students, who successfully completed this graduation requirement over the past two years (n=130), the research subject and topics of investigation provide insight into areas students were interested in investigating further. Three main areas of focus, which enabled students to demonstrate their understanding of the present event context, have emerged: perception/satisfaction of different stakeholders, event impacts, and innovation and development.

Keywords: MICE training, leadership development, competence in practice, events pedagogy

INTRODUCTION

A great planner is to the success of an event what a top of the league football coach is to a big win. By nature, successful event organisation and management requires the collaboration of a qualified team of individuals working toward the realisation of a singular vision. So how then, are event leaders trained and developed, and to what extent can higher education institutions (HEIs) raise the efficacy of future industry leaders in this field?

With a recent report from the World Travel and Tourism council (WTTC) suggesting that the current tourism and hospitality sector either directly or indirectly, supports one in eleven jobs worldwide in addition to a continued growth forecast of 3.3% for the industry annually until 2030; human resource development and qualification needs have increased pressure on higher education institutions (HEIs) to prepare graduates for employability (UNWTO, 2016). In that the management of the meeting, incentive travel, convention, and exhibition (MICE) events provide a unique opportunity for a destination to refresh its tourism product offerings - degree and professional certification programs in this field have rapidly emerged, spurring a race to maintain competitive advantage through delivery of quality programs. Identifying and satisfying students' needs and expectations via provision of quality learning opportunities, thereby enhancing employability skills, has become essential (Butt & Rehman, 2010). Political

and economic pressure to prepare graduates, who can cope with shifting requirements and constantly evolving technological advances, is a real challenge (Sigla, 2012). Due to the complexity of the workforce skills needed, combined with the demand for high quality service provisions, a number of scholars agree that HEI's are the best source for ensuring capacity development (Enberg, 2007; Eurico, Silva, & Valle, 2015).

Since authentic simulation of event management planning, execution and follow-up often involve teamwork or collaboration, this research explores the propensity for critical thinking, leadership and problem solving demonstrated by senior students through the conceptualization, execution and write-up of an individual research thesis as a graduation requirement. While the research dissertation is an established component of many undergraduate programmes, this study explores the potential it presents for undergraduate event management students to enhance their own employability.

LITERATURE REVIEW

Based on existing literature, there is sufficient documentation regarding the combination of pedagogic approaches recommended for providing undergraduate students with sufficient, knowledge, skills and competence – in practice, to confidently enter the workplace upon graduation. The presentation of industry relevant knowledge, constantly informed and updated by competent industry stakeholders, (Ayers, 2006; Butt & Rehman, 2010; Feng, Chiang, Su, & Yang, 2015), the acquisition of skills and hands-on experience with equipment and practices deemed valuable by current industry practice, (Baum, 2007; Borrajo et al., 2010; Butt & Rehman, 2010) and a variety of opportunities to utilise existing knowledge and skills in authentic problem solving and task production with enhancing complexity over the course of the programme (Aggett & Busby, 2011; Barron, 2007; Eurico et al., 2015) constitute curriculum components addressed in programmes deemed successful.

Figure 1
RELATIONSHIP BETWEEN LEARNING OUTCOMES (Nygaard & Holtham, 2008)

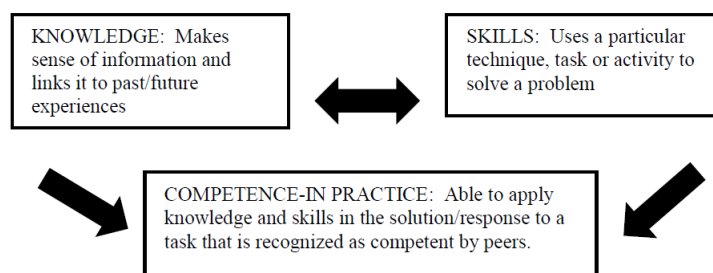

Knowledge (not information) is one outcome of the learning process through which the learner has the ability to perceive information, to create meaningful connections and to link these both to past experiences as well as projecting them to future scenarios. In this way, knowledge is not a limited possession of the learner, but is contextual and gains relevance when shared. While knowledge provides the basis through which we analyze problems and can determine the action required to solve problems – it is the application of skills (using a specific technique or performing a specific task or activity) that form these determined actions. Skills represent the second outcome of learning. The third outcome of learning has to do with the application of one's knowledge and skills to solve or address a task in such a way that is recognized as competent by relevant peers. Nygaard and Holtham (2008) identify this as 'competence-in-practice' (p. 15) and suggest it comprises three aspects: 1) to possess the competence to solve a problem in practice, 2) to possess the ability to apply one's competence and contextual

knowledge and 3) to be recognized as competent by more experienced peers in the social collectives through which one has membership (Fig. 1).

Internships, practical skills training and project based assessment constitute those programme elements that provide students not only the opportunity to garner relevant experience but to have their capacity recognised by key industry stakeholders. According to findings reported in an Australian study conducted by Ayers (2006), senior managers acknowledge the skills and maturity acquired through academic study in a HEI “...what education does is help to reinforce some of the person’s belief in their own ability, their own management skills, organisation skills etc.” (p. 24). Though even when a programme offers a good balance between professional knowledge, practical application of skills and real-world work experience through an internship, sufficient opportunity may not exist within a four-year programme for the majority of students in the cohort to demonstrate individual capacity to lead. Nor is it always the case that academic success directly translates to professional success. “Employers and their representatives consistently say that to succeed at work, most people in future must develop a range of personal and intellectual attributes beyond those made explicit in programmes of study in HEIs” (Harvey, 2010, p. 8). Nonetheless, there are obvious advantages for one who pursues an undergraduate degree to attain professional qualification over someone who enters the job market without it:

1. The scope and range of challenges one is exposed to in HE are wider, more varied and more rigorous (Baum, 2007).
2. The undergraduate student is encouraged and given opportunity to experiment with risk taking /entrepreneurial behavior without the threat of high stakes consequences (e.g. acquiring a low grade vs. a negative employment record) (Whitelaw & Wrathall, 2015).
3. HE provides a healthy combination of professional mentoring, industry networking and a platform to be recognised for achievement and not denounced for failure (Lydon, Dyer, & Bradley, 2014).

In order to provide sufficient opportunity for any student aspiring to demonstrate capacity in individual leadership, problem solving and critical thinking, this study investigates the potential presented in a research thesis/project required by one event management programme as a graduation requirement.

METHODOLOGY

An exploratory case study utilising a qualitative approach was employed in this investigation. The rationale for using a qualitative approach was ‘to enable a social enquiry focusing on the way people (in this case sr. students) interpret and attach meaning to the world around them’ (Holloway & Wheeler, 2002, p. 19). Lave and March (1975) introduced the idea of ‘thought experiment’ as a means of speculative model building whereby human behavior is compared to a form of art which in its creation requires a combination of discipline and playfulness and lends itself to a wide range of interpretation (p. 4). While considerable attention has been given to curriculum design, pedagogic effectiveness and deconstruction of components constituting employability in regard to higher education – far less attention has been placed on ways in which university students co-create their learning experience. Content analysis of research dissertation titles selected by different cohorts of fourth-year event management students at one HEI in Macao, who successfully completed their thesis/project assignment over the course of two academic years, were analyzed (n=130). The analysis sought to gain insight into areas of investigation that students chose to focus on in completing this capstone project. While a

dissertation title is limited in communicating the full scope and depth of the final product, it provided a glimpse into the research subject and premised the research objective. Through these snapshots, patterns in what students were investigating began to emerge.

It is noteworthy to mention that in the design of the thesis/project requirement of this institution, an opportunity for public recognition was built in. Ambitious students in this particular HEI were further incentivized by the chance to have their work published (ISSN) in an e-Proceedings, associated with the Tourism Education Student Summit event (TEd Summit) through which invited students present their research findings, to a panel of academics, industry leaders and the community at large, twice annually. Outstanding work is nominated by supervisors to present in the event and undergoes a double-blind review process to be invited (80% acceptance rate). Altogether 22% (n=28) of all event students referred to in this study, were successful in attaining this opportunity to present and publish.

FINDINGS AND DISCUSSION

In its commitment to prepare graduates for a leading role within the future of the events industry, senior students of this HEI were required to individually utilise scientific investigation to examine and critically analyse their surroundings in the form of an undergraduate research thesis, before graduation. The investigative process ensured that students engaged, under the guidance of a faculty supervisor, in conceptualising the research objective, designing the research plan, creating relevant instruments, and implementing the investigation. The final thesis/project represented a 7,000-10,000 word English dissertation in which the student was required to gather primary data which addressed the research objective. To assist in the fruition of this senior thesis/project, support services were set up, namely to assist with language coherence and provide support for research analysis queries. A closer analysis of dissertation titles indicate three main areas students focused their investigation on.

The first was in regard to the perception/satisfaction of different stakeholders (Table 1); students who followed this line of investigation sought to gain understanding of how different stakeholders such as local residents, event organisers, local suppliers, government officials and non-resident participants viewed events of different sizes, legacy and duration.

As suggested by Ruggeroni (2001) students pursuing an examination of this kind may have sought to immerse themselves to acquire authentic understanding about the tourism event market. To one who has chosen to enter the event industry, there is an obvious advantage in understanding what constitutes satisfaction and the different perceptions of event stakeholders, participants, attendees (local and non-local) as well as different segments of the market you will serve. Lydon et al. (2014) refer to this process as developing privileged insight. Market research can equip the professional with valuable information regarding factors contributing to satisfaction, intention to return or motivation to attend events. Of the 55 theses which explored stakeholder satisfaction or perception, a wide range of topics were included.

Small scale cultural festivals such as ‘The Drunken Dragon Festival,’ ‘Feast of the God Tou Tei,’ ‘Chinese New Year Parade,’ ‘A-Ma Festival’ or ‘Lusofonia’ which tend to be organised by community associations represent intangible heritage that preserve important traditions, and are essential to convey the unique identity of Macao to visitors. Alternatively, some students chose to focus their attention on annual events organised by the Macao Government Tourism Office (MGTO) for the purpose of attracting tourists: ‘The Macao Food Festival,’ ‘The Grand

Prix,' 'The International Music Festival,' 'International Fireworks Festival,' and 'The Macao Arts Fair' just to name a few are larger scale events supported by larger budgets, greater sponsorship involvement and wider media coverage. As well, some students focused on large commercial entertainment events organised by private hoteliers seeking to ensure competitiveness of their integrated resorts like 'Concerts in the Cotai Arena.'

Noticeable also were the lines of enquiry that sought to examine the opinion of event management peers and their experiences.

Table 1
STAKEHOLDER SATISFACTION & PERCEPTION

Satisfaction (n=35)		University Students	Macao Charity Bazaar
Research Subjects	Topics		
Attendees (n=7)	China Int'l Machine & Tool Exhibition	Visitors (n=3)	Lusofonia Festival
	Festivals in Macao		Macao Food Festival
	China Air-show		MICE Events (Loyalty)
	Music Events	Volunteers (n=2)	Macao Events (n=2)
	International Music Festival	Perception (n=20)	
	Cotai Arena Concerts	Research Subjects	Topics
	Macao Food Festival	Event Student	Event Management Programmes (Macao vs. China)
Event Students (n=5)	Programme Selection (n=2)	Local Resident (n=11)	Macao Art Fair
Exhibitors	Internship Selection		Macao Light Festival
	Macao MICE Industry (n=2)		Macao Grand Prix (n=3)
	Macao Food Festival		Macao Food Festival
Gen Y	Industry Employers		Chinese New Year Parade
Local Residents (n=12)	Drunken Dragon Festival		Food Events in Macao
	International Music Festival		Chinese New Year Celebrations
	Macao Food Festival (n=3)		International Music Festival
	Macao Arts Festival (n=2)		Macao Art Events
	Macao Art Fair (n=2)		Feast of the God Tou Tei
	Social Media Posting (Post Event)		A-Ma Festival
	International Fireworks Festival	Local Youth (n=3)	Macao Events
Wedding Ceremonies		Drunken Dragon Festival	
Participants (n=3)	Macao Grand Prix	Macao Couples	St. Valentine's Day
	Macao Food Festival	Non-Local Exhibitors	Macao MICE Industry
	Feast of God Tou Tei	Participants	Water Sport Events
		Youth	Green Event Experience

Another focal point pursued by students was event impacts (Table 2). Regardless of whether investigation guided them to understand more about positive or negative impacts, these research dissertations gave students the opportunity to think about logistics, analyse problems and often consider recommendations for either sustaining positive outcomes or mitigating negative ones. Similar to the process of knowledge exploration through critical analysis and problem solving recommended by Borrajo et al. (2010), examining the implications of events on the economy, transportation, communication, socio-cultural considerations, destination image or stakeholder experience enabled these students to attain a better understanding of the event industry.

Some students who followed this course of exploration, analysed the effectiveness of a variety of communication platforms used before, during and after the event such as 'billboards,' Facebook Fanpages / daily news,' 'online social networks' and 'word of mouth (WOM) communication' for events of differing scopes, scales and purposes. Another popular line of enquiry had to do with how especially large scale events affected societal routines,

examples of these topics included ‘road closures during Grand Prix,’ ‘cultural influence of international performances,’ ‘foreign celebrations such as MGM Oktoberfest,’ ‘impact of the Macao Food Festival on destination image’ and opportunities for ‘local athletes qualifying for the AFC Asian Cup.’

Concentration on event impacts provided these students with an accurate understanding of information that can advise them how to enhance positive impacts and prevent negative ones in future event planning. This knowledge places the recipient in a position of privilege within a project team. In essence the student researchers are creating authentic case studies, similar to those Jackson (2015) suggests as useful for training ‘the use of more realistic case studies with a structured framework to guide reasoning, analysis, diagnosis and decision making was considered by some to enhance valuable critical thinking and problem-solving skills’ (p. 16).

Table 2
EVENT IMPACTS

Event Impacts (n=32)			
Impact Subject/Source	Topics of Impact	Impact Subject/Source	Topics of Impact
Billboard Advertisements (n=2)	Macao Hotel Brand Image	Road Closure	Grand Prix
	MOA & Customer Attitude	Social (n=3)	Tam Kung Festival (cultural)
Destination Image	Macao Food Festival		Grand Prix
Economic	International Music Festival		Macao Arts Festival
Event Organisers	Music Concert	Socio-Cultural (n=7)	International Music Festival (n=2)
Facebook Fanpage/ Daily News	Macao Arts Festival Branding		Feast of God Tou Tei (cultural)
Local Football Players	Qualifying for AFC Asian Cup		MGM Macao Oktoberfest
Local Resident (Impulse Buying Behaviour)	Lunar New Year Fair		Chinese New Year Parade
Local Residents (n=9)	Macao Food Festival		Classical Music Concerts (as perceived by Organisers)
	Art Festival		Artmusing Summer Workshop
	HUSH Concert (local band)		Transportation
	Grand Prix (n=4)	Visitor Experience	Grand Prix
	Religious Festivals	WOM Communication	Macao Food Festival
Online Social Networks	Lusofonia		
	China Music Festival Attendance		

The third form of investigation focused on aspects of innovation and development (Table 3); students engaging in this research direction looked at improving or assessing aspects of event execution, identifying relationships among investigated elements, enhancing service provision, and incorporating innovation in regard to event management. The advantage of this form of investigation as advised by Sigla (2012) is to explore new potential while mitigating economic risk or loss.

Students pursuing this course of investigation worked to assign interpretation to observed patterns of behaviors either through identifying models, exploring potential for future development or considering a means through which existing reality could be assessed.

Table 3
INNOVATION AND DEVELOPMENT

Event Impacts (n=43)			
Research Objective	Topics Investigated	Research Objective	Topics Investigated
Authenticity Degradation	Feast of the Drunken Dragon	Evaluation (n=2)	Incentive Travel Market-Macao
Contribution	Portuguese Festivals and Events (cultural)		Macao's Potential Hallmark Events
Correlation	Traffic Management and Tourist Behaviour	Expenditure (Market Segmentation)	Macao International Music Festival
Creative Clusters (n=3)	Entrepreneurship	Impulse Purchase Behaviour	Macao Food Festival
	Macao International Sports Events (Sponsorship)	Legacy Management	2008 Beijing Olympic Games
	Elements of HUSH Concert (Green Event)	Loyalty Model (n=2)	Macao Grand Prix
Cultural Identity	Jiao Festival in Cheung Chau, HK		Macao Latin City Parade
Customer Arrival Patterns	McDonald's Macao	Potential (n=5)	Macao Latin City Parade (n=2)
Destination Rebranding	Macao Grand Prix		Macao as an Event Destination
Development	Macao's Cultural & Creative Industries		Tourism Event Industry in Macao
Diversification (n=2)	Macao Performing Arts Events		Religious Tourism in Macao
	Corporate Events		Potential for Co-Branding
Effectiveness	Promotional Video	Safeguarding	Procession of Our Lady of Fatima
Evaluation (n=8)	Macao Food Festival (n=2)	Success Indicators	Exhibitions in Business
	Macao Grand Prix	Sustainability (n=3)	The Feast of Drunken Dragon Festival
	Transportation in Event Logistics		Macao's Event Industry
	Macao Arts Festival		Macao Food Festival
	Event Management Education (HEI)	SWOT Analysis	Macao as a MICE Destination
	Event Management Curriculum (HEI)	Transmutation	MICE in Macao
	Macao's Exhibition Servicescape	Youth Education (n=2)	Traditional Chinese Festival of Macao
			Lunar New Year

Through the assignment, students were able to explicate aspects of ongoing practice, informed by extant theory learned throughout their study programme – a key learning outcome recommended by Whitelaw and Wrathall (2015). More than a quarter of these studies (n=15/43) considered how to measure different aspects of performance related to events. While students continue to focus on events similar to those previously identified as topics of investigation, they are utilising a different methodological approach. These theses sought to assess areas such as ‘exhibition servicescape,’ MGTO sponsored events (Grand Prix, Food Festival, Arts Festival...), diversification as it relates to corporate entertainment offerings or performing arts, and infrastructure such as transportation, professional training or event status. Another line of enquiry under this form concerned the development of models. These included five sustainability studies, which focused on a range of topics from preventing commercialisation of intangible heritage to ensuring environmental preservation in event execution; an additional six studies examined behavioral models which covered a range of topics from spending behavior, to arrival patterns to event loyalty and attendee revisit intention. Another fourteen studies considered potential growth areas – these ranged from

expanding the involvement of the creative industries, destination image adjustment, maximising value for cost through legacy management to the transmutation of the MICE industry of Macao.

CONCLUSION

This study suggests that an individual research investigation not only offered students a chance to demonstrate competence in practice, but empowered them to apply the professional knowledge and skills developed through the undergraduate study in a customized way, thereby co-creating their own learning experience. Future research can conduct a more thorough investigation of the thinking that went into each student's selection process, as reported by the student, and follow-up on the extent to which, if any, this exercise was perceived by the students as enhancing their future career prospects.

Where previous studies have looked at improving the implementation and/or pedagogic structure of events management training in higher education, this study is the first to explore the potential for demonstrating individual competence in practice through an individual academic assignment.

Based on the preliminary results of this study, HEI's can explore more ways in which individuals can be recognized for their individual leadership/management capacity within this team-oriented field of events management.

REFERENCES

Aggett, M., & Busby, G. (2011). Opting out of internship: Perceptions of hospitality, tourism and events management undergraduates at a British University. *The Journal of Hospitality Leisure Sport and Tourism*, 10(1), 106-113. doi:10.3794/johlste.101.310

Ayers, H. (2006). Education and opportunity as influences on career development: Findings from a preliminary study in Eastern Australian tourism. *Journal of Hospitality, Leisure, Sports & Tourism Education*, 5(1), 16-28.

Barron, P. (2007). Hospitality and tourism students' part-time employment: patterns, benefits and recognition. *Journal of Hospitality, Leisure, Sports & Tourism Education*, 6(2), 40-54.

Baum, T. (2007). Human resources in tourism: Still waiting for change. *Tourism Management*, 28(6), 1383-1399.

Borrajo, F., Bueno, Y., de Pablo, I., Santos, B., Fernandez, F., & Garcia, J. (2010). SIMBA: A simulator for business education and research. *Decision Support Systems*, 48(498-506).

Butt, B., & Rehman, K. (2010). A study examining the students satisfaction in Higher Education. *Procedia Social and Behavioral Sciences*, 2, 5446-5450.

Enberg, M. E. (2007). Educating the workforce for the 21st century: a cross-disciplinary analysis of the impact of the undergraduate experience on students' development of a pluralistic orientation. *Research in Higher Education*, 3(48), 283-317.

Eurico, S., Silva, J., & Valle, P. (2015). A model of graduates' satisfaction and loyalty in tourism higher education. *Journal of Hospitality, Leisure, Sports & Tourism Education*, 16, 30-42.

Feng, L., Chiang, M.-H., Su, Y., & Yang, C.-C. (2015). Making sense of academia–industry cooperative teaching. *Journal of Hospitality, Leisure, Sport & Tourism Education*, 16, 43-47. doi:10.1016/j.jhlste.2015.02.001

Harvey, L. (2010). New realities: The relationship between higher education and employment. *Tertiary Education and Management*, 6(1), 3-17.

Holloway, I., & Wheeler, S. (2002). The nature of qualitative research: Development and perspectives. Holloway, I. & Wheeler, S. *Qualitative Research in Nursing*. 2nd edition. Blackwell Science Ltd. USA. MPG Books Ltd, 3-25.

Jackson, D. (2015). Employability skill development in work-integrated learning: Barriers and best practice. *Studies in Higher Education*, 40(2), 350-367.

Lave, C., & March, J. (1975). *An introduction to models in the social sciences*. New York, NY: Harper & Row.

Lydon, J., Dyer, D., & Bradley, C. (2014). *Compete to prosper: Improving Australia's global competitiveness*. Melbourne: McKinsey.

Nygaard, C., & Holtham, C. (Eds.). (2008). *The need for learning-centred higher education*. Denmark: CBS Press.

Ruggeroni, C. (2001). Ethical education with virtual reality: Immersiveness and the knowledge transfer process. In G. R. F. Davide (Ed.), *Communications Through Virtual Technology: Identity, Community and Technology in the Internet Age*. Amsterdam: IOS Press.

Sigla, M. (2012). Exploiting Web 2.0 for new service development: Findings and implications from the Greek tourism industry. *International Journal of Tourism Research*, 14, 551-566.

UNWTO. (2016). UNWTO tourism highlights. Retrieved from Madrid, Spain: <http://www.e-unwto.org/doi/pdf/10.18111/9789284418145>

Whitelaw, P. A., & Wrathall, J. (2015). Developing practice oriented undergraduate courses in a quality framework: A case study; bachelor of event management. *Quality Assurance in Education*, 23(4), 395-409.

SUPPORT FOR GREEN CONFERENCES ONLY LIP SERVICE – SO WHAT CAN BE DONE?

KATHRIN BÖCK

Bournemouth University, UK

JULIE WHITFIELD

Bournemouth University, UK

LEONARDO DIOKO

Institute for Tourism Studies, Macao

ABSTRACT

Although support for making conferences more green and sustainable have grown over the years, such philanthropic considerations are overshadowed by the hard factors ultimately determining attendance to conferences. These include factors such as time and distance, the nature of the conference, and destination attractiveness. Environmental sustainability of the conference or the venue remains a poor influencing factor. This study therefore examines to what extent various ‘conference green attributes’ or sustainable interventions are related to hard factors and if so determine ways of influencing attendees to be more selective toward green conferences. The study explores this relationship in a sample of German conference attendees, with results indicating support for the status quo but also reveals some potential avenues for changing attendees’ preference for green conferences.

Keywords: green conferences, hard and soft factors, environmental sustainability

INTRODUCTION

Research undertaken in the field of conference tourism has revealed that delegates’ recognition of negative environmental impacts is increasing (Han 2014). Thus, staying competitive can be facilitated by implementing green practices into conferences (Han and Hwang 2016). Consequently, various studies have focused on the importance of greening on the supply side (Lee et al. 2013). German publications have put an emphasis on green meetings during the last few years (Wagner 2014; GCB 2016b) as well as the largest European fair for the meetings industry (taking place in Frankfurt) ‘Incorporating Meetings made in Germany - The Worldwide Exhibition for incentive travel, meetings and events’ (IMEX) has focused on greening and sustainability (Fink 2016). Research focusing on the conference participant however is still limited to special aspects and specific conference venues (Lee et al. 2013; Wong et al. 2014; Han and Hwang 2016). Therefore the aim of this article is to examine to what degree sustainable efforts of the supply side are important for delegates as well as if they even have an impact on their decision-making process to attend a conference.

LITERATURE REVIEW

Consumer behaviour and consumer decision-making

Consumer behaviour and consumer decision-making is a process of receiving and systemising information with the aim to make a decision and to consume a product or service (Moutinho 1987). Aspects underlying consumption are motives or needs which want to be satisfied and which result in a drive or action (Evans et al. 2009). The expectancy-value model (Fishbein

and Ajzen 1975) takes up this point and assumes that one's motivation to take action relies upon the expectancy whether the action will result in an incentive accompanied by a personal value or not (Roese and Sherman 2007). As research in the events industry is still limited parallels are often drawn to the tourism sector (Mair and Thompson 2009). So it was done with the research field of motivation and the 'theory of reasoned action' (TRA), one representative of the expectancy-value models (Yoo and Chon 2010). According to the TRA, a person's motivation to perform a specific behaviour can be attributed to its intention (Fishbein and Ajzen 1975). This intention is influenced by the person's own attitude towards an action as well as by subjective norms (Perugini and Bagozzi 2001, Prayag et al. 2013). Lortie and Castogiovanni (2015, p. 938) equate these subjective norms with a "social pressure" in form of attitudes or expectations that referent others have regarding the performance of a behaviour.

In further studies Ajzen (1985) discovered limitations in his theory and revised his work by adding the concept of perceived behavioural control (PBC) to the TRA. The new model was called 'theory of planned behaviour' (TPB) (Song et al. 2012) and is meanwhile described as one of the most applied theories in terms of foreseeing and explaining individual's behaviour (Lortie and Castogiovanni 2015). The TPB reflects that not only attitude towards behaviour and subjective norms is influencing a person's intention but also one's perception "[...] of the ease of performing certain behavior" (Horng et al. 2013, p. 196). Experiences act a part in the evaluation to what degree a future behaviour can be controlled and how easy or difficult the performance is perceived (Lortie and Castogiovanni 2015). The PBC can independently and directly influence behaviour (Armitage and Conner 2001).

One point of criticism regarding the TPB is that not all behaviours are rational (Planing 2014; Sniehotta et al. 2014). Unconscious influences on behaviour, like emotions, are neglected (Sheeran et al. 2013) and no cognitive or affective processes are taken into consideration (Arvola et al. 2008). Ajzen (2011) defends himself in stating that the model neither assumes that those beliefs are rational or without any influences nor does it represent accurate reality. Those beliefs can be irrational and biased by emotions like for instance anger, pride or guilt (ibid.). Apart from how people's beliefs are materialised, their perceptions of behavioural control as well as attitude and intentions eventually and automatically follow from those beliefs (Geraerts et al. 2008; Ajzen 2011).

The TPB conveys an understanding of the motives that lie behind a consumer's behaviour by analysing the variables which influence a consumer in the consideration of taking action or not (Schiffman and Kanuk 2004). While there has been a lot of research in the tourism market regarding the decision-making process of a leisure tourist (Mair and Thompson 2009), the field of business tourism and especially the conference industry has been mostly neglected so far (Abbey and Link 1994; MalekMohammadi and Mohamed 2011). Most studies in this area have focused on the supply side, which leaves the conference participant as an under researched field behind (Leach et al. 2008).

However, there has already been a development since Lee and Back (2005) stated that the lack of moderate and trustworthy theoretical framework in the field of conference participants' decision-making and the influencing factors constitute a real problem. This is shown by the amount of attendee-related studies in the conference market (Var et al. 1985; Oppermann and Chon 1997; Rittichainuwat et al. 2001; Severt et al. 2007; Zhang et al. 2007; Leach et al. 2008; Yoo and Chon 2008; Mair and Thompson 2009; Yoo and Zhao 2010). Studies have in common that they take the paradigm of cognitive decision-making as a starting point (Yoo and Chon 2010) which strengthen the argumentation of Arvola et al. (2008) regarding the influence of

emotions and bias into behaviour. The underlying factors are better known as ‘push’ and ‘pull’ factors (Oppermann and Chon 1997; MalekMohammadi and Mohamed 2011).

There has been done lots of research on examining the factors or attributes that ‘push’ or ‘pull’ and therefore, also like the TPB states, influences a consumer in taking action or not, specifically: influence participation in any meetings, incentives, conventions or exhibitions (MICE) or other related events (Whitfield et al. 2014a). However, respondents to interviews or questionnaires have mainly been meeting or/and event planners (Whitfield et al. 2014b). In order to increase attendance and to boost delegate satisfaction few studies have also dealt with factors which have an effect on the decision-making process of delegates whether to attend a conference (MalekMohammadi and Mohamed 2010; Targeted News Service 2015).

Attributes affecting conference participation decision-making

The current state of research presents one model of conference attributes by Zhang et al. (2007) which is based on Oppermann and Chon’s (1997) version. In comparing these two models it is noticeable that location factors have been divided into ‘attractiveness’ and ‘accessibility’ (Zhang et al. 2007). Moreover, Oppermann and Chon’s (1997) ‘intervening opportunities’ have been taken out and a ‘total cost factor’ has been added including ‘monetary cost’ and ‘time cost’ (ibid.). This approach is identical to Var et al.’s (1985) statement that costs have a strong influence on account of the constraint of resources. Conference factors (e.g. programme, networking, learning effects) and personal factors (e.g. time availability, previous experiences) have remained unchanged (Zhang et al. 2007). The most noticeable fact against the background of this article is the neglect of any attributes which are related to sustainability or ecology. Research in this area started around 2008 (Rogers 2008). However, it seems as if environmentally friendly practices have not been considered as influencing attributes when examining general impacts on the decision-making process. This is contrary to the fact that among researchers and industry professionals it can be identified a universal agreement regarding the fact that the trend towards implementing sustainable or green practices in conferences as well as in venues is growing (Rogers 2008; Smith-Christensen 2009; Thomson 2009; Merrilees and Marles 2011; Goldblatt 2012).

Green conference industry in Germany

Sustainability is defined as a central topic in the German conference industry and the implementation of green meetings into the meetings and conference industry has been set as one key objective by the German Convention Bureau (GCB) (GCB 2016b). In this context, several initiatives have been created to take sustainable practices into account (ibid.). In 2012, the German Convention Bureau (GCB) and the European Association of Event-Centres (EVVC) have initiated the ‘fairpflichtet – Sustainability Code of the German Event Industry’ which is described as a voluntary entrepreneurial commitment for managerial responsibility in the organisation and implementation of meetings and events (GCB and EVVC 2016a). But this is only one initiative besides others used in Germany: the Green Globe Certification Standard (Green Globe 2016a), ‘Sustainability Consultant’ seminars (GCB 2016c), the standard of the International Organization of Standardisation (ISO) ISO 20121 (ISO 2016a) or the German Sustainable Building Council (DGNB) certification (German Sustainable Building Council 2016a). During the last few years, companies or associations have also used the sustainability movement in the events and conference industry as a new opportunity for business (Moderer et al. 2012). The FAMAB communications association for fair architects, event agencies and event caterers has for example launched its own ‘sustainable company’ and ‘sustainable project’ certifications (FAMAB 2016).

Behind this background of the importance of sustainability in German conference industry, the central research questions of the study focuses on the perception and importance of sustainability on the side of the delegate: (a) determine the relative importance of environmental sustainability considerations in German conference attendees' decisions to attend conferences, and (b) determine the extent with which several environmental interventions—promoting the importance of green conferences, promoting the importance of green venues, promoting individual green attitudes and behaviors, and promoting company support for sustainable policies—affect the importance of various considerations (conference attributes, environmental sustainability, time, distance, and cost, as well as destination image and attractiveness) which German conference attendees consider when deciding to attend conferences.

METHODOLOGY

Data collection. An online survey of conference attendees in Germany was conducted between 12 July 2016 and 15 August 2016. The survey targeted delegates who have taken part in one or more domestic German conference during the last two years. For conducting the survey a mixed method of mail embedded URL and openweb based questionnaire was chosen. A pilot test was sent out to 15 random delegates. They were asked to both answer the questionnaire and to comment aspects like wording, ambiguous questions, layout, sequencing and length of the questionnaire. Based on these pilot responses the questionnaire was revised. Afterwards, 311 delegates from several participation lists of conferences in 2016 have been invited by a personalised email to take part in the survey, aiming to address them personally and create a higher response rate (Heerwegh et al. 2005; Trespacios and Perkins 2016). Further respondents were recruited via social business networks XING and LinkedIn. The survey URL was published in business events communities as well as it was mentioned in groups related to conferences and sustainability. Besides, the survey was supported by 'tw tagungswirtschaft' a German trade magazine and by veranstaltungsplaner.de a German MICE association via their social media channels as well as the online survey was integrated into their newsletter. In total, 134 delegates completed the questionnaire.

Measures. Four predictor and four dependent variables were included in the study. The four dependent variables were factors derived by principal components analysis conducted to reduce an original inventory of 9 items designed to capture various considerations determining respondents' decision to attend a conference. Respondents indicated how influential each item is in their decision to attend conferences using a 5-point Likert degree of influence scale anchored on each end by 5-very high influence and 1-very low influence. The original 9 items are listed in Table 2 below, arranged depending on the four derived principal components (PC) to which each loaded after factor analysis as is the post-varimax extraction correlation estimate of each item with the derived factors, as well as the % of variance accounted for by each of the four derived principal component. All assumptions required for factor analysis was met, with KMO sampling adequacy (.703) and Bartlett's test of sphericity resulting in significant test value (493.97, df=36). All 9 items inputted for analysis had MSA values greater than 0.50.

The predictor variables consisted of four summated scales each of which was comprised of several items. These include (1) the importance of green attributes in conferences, 12 items measured using a 4-point Likert scale (4-very important, 1-not very important), maximum 48 points, (2) the importance of green attributes in conference venues 5 items also measured using a 4-point Likert scale (4-very important, 1-not very important), maximum 20 points, (3)

individual attitudes about “greening” and traveling to a conference (7 items, 5-point agreement scale), maximum 35 points, and (4) company support for sustainability policies (2-items, 5-point agreement scale), maximum 10 points. Altogether, these four predictor variables represent environmental interventions or measures that can be used to improve conference attendees’ environmental considerations when deciding to attend a conference.

Analysis. As the aim of the study is to determine how environmental sustainability considerations can be enhanced for conference attendees when deciding to attend a conference (relative to other considerations such as the conference attributes, time, distance, cost, and destination attributes), separate multiple regression analyses were conducted for each of the four principal components which altogether comprise the different dimensions of considerations influencing attendees’ decision to attend a conference. Each principal component was therefore assigned as the dependent variable in separate multiple regression runs. The goal of the analysis was to quantify relative influence via the beta coefficients of the predictor variables (i.e., promoting green conference attributes, green conference venues, fostering attendees’ green attitudes and travel, and company support for sustainable policies).

FINDINGS

Sample profile. A total of 134 respondents with complete data were collected at the end of the survey period. Majority of the respondents (59%) attended between 1 to 2 conferences within the last year. The conferences were mostly (53%) corporate conferences followed by association conferences (37.3%). Slightly more than half the respondents were female (55.32%). More than half the survey respondents were young professionals or occupied lower line positions in their organizations and more than half the respondents belonged to the finance, media, or healthcare industries. See Table 1.

Importance of environmental sustainability of considerations. Mean ratings (and s.d.) for the different scale items loading onto each of the four factors were calculated and compared. The results are reported in the last two columns of Table 2. For this sample of German conference attendees, the most important factor influencing their decision to attend conferences is the conference attributes ($M = 4.28$, $SD = .67$). This is followed by time, distance, and cost considerations ($M = 3.76$, $SD = .87$) and considerations regarding the attractiveness, image, and safety of the destination ($M = 3.06$, $SD = .92$). Environmental sustainability rated the lowest among the four factors considered when attending conferences ($M = 2.51$, $SD = 1.04$).

Effectiveness of environmental interventions in influencing attendees’ decision to attend conferences. Separate multiple regression analysis was conducted with the four PC components inputted as dependent variables in each run. The four environmental interventions (importance of green conference, importance of green venues, individual green attitudes, and company support for sustainable policies) were inputted as predictor variables for all analyses. As the current inquiry involves an exploratory approach, the predictor variables were inputted in step-wise fashion.

The intercorrelation matrix between the different variables used in the analyses, as well as their respective means and standard deviation, are reported in Table 3. All assumptions necessary for conducting step-wise multiple regression were met: Collinearity statistics showed VIF values ranging from 1.085 (for company support for sustainable policies) to 2.087 (for individual green attitudes). Tolerance values ranged from .479 (individual green attitudes) to .921 (for company support for sustainable policies). Durbin-Watson value = 2.052, which indicates that the assumption for independent errors was met. Examination of the distribution

of residuals and P-P plots of standardized residuals revealed no anomalous patterns that would invalidate the model.

Table 1
SAMPLE CHARACTERISTICS OF GERMAN CONFERENCE ATTENDEES

		N	%
No. of conferences attended	1-2	79	59.0
	3-5	42	31.3
	More than 5	13	9.7
Type of conference attended	Corporate conference	71	53.0
	Association conference	50	37.3
	Governmental conference	13	9.7
Gender	Female	74	55.2
	Male	60	44.8
Position	Trainee / Apprentice / Intern / Working student	35	26.1
	Secretary/Assistant/Clerk in Charge/Project Leader	21	15.7
	Young professional	21	15.7
	Head of Division / Department	12	9.0
	Others	10	7.5
	Managing Director / Chairman of the Board	8	6.0
	Division Manager / Production Manager	7	5.2
	Director	4	3.0
	Authorised Officer with Procurement	4	3.0
	Owner	4	3.0
	CEO, CFO, COO etc.	3	2.2
	Managing Partner	3	2.2
	Vice Chairman / Member of the Board	1	.7
	Chairman / Member of the Supervisory Board	1	.7
	Industry	Finance / Insurance / Real Estate	29
Communication / Marketing / Media		24	17.9
Healthcare / Pharmaceutical industry		17	12.7
Food Services / Hotels / Tourism		13	9.7
Construction / Car industry / Transport / Logistics		9	6.7
Legal Services / Consulting		9	6.7
Research / Education		9	6.7
Telecommunications / IT / Technology		7	5.2
Others		6	4.5
Wholesale and Retail Trade		5	3.7
Energy / Environmental		3	2.2
Government / Civil Service		3	2.2

Table 2
FACTORS CONSIDERED IN DECISION TO ATTEND A CONFERENCE

Factors (extracted), scale item loadings, and post rotation correlation estimates	Component % of variance	Degree of influence*	
		Mean	s.d.
Conference attributes (PC2)	24.6	4.28	(.67)
(1) Programme, content, speakers (.55)			
(2) Networking opportunities (.89)			
(3) Professional advancement (.82)			
Time, distance, & cost (PC3)	10.8	3.76	(.87)
(4) Monetary and time cost (.69)			
(5) Travel distance (.82)			
Destination image, attractiveness, safety (PC4)	8.4	3.06	(.92)
(6) Attractiveness of destination/image (.73)			
(7) Safety/security of destination (.83)			
Environmental sustainability (PC1)	33.2	2.51	(1.04)
(8) Env. sustainability of conf. venue (.94)			
(9) Env. sustainability of conference (.95)			

*5-point scale, 5-very high influence and 1-very low influence

Table 3
 INTER-CORRELATION MATRIX (PEARSON) AND DESCRIPTIVE STATISTICS
 (N = 134)

	Importance of green conferences	Importance of green venues	Individual's green attitudes	Support from company for green meetings	PC1: Env. sustainability of conference & venue	PC2: Conf. attributes & career benefits	PC3: Time, distance, effort, & cost	PC4: Dest. Image (safety, appeal)
Importance of green conferences	1	0.6585	0.6736	0.2803	0.4867	0.0405	0.1629	0.0160
Importance of green venues	0.6585	1	0.5954	0.3756	0.4865	0.1641	0.1374	0.1866
Individual's green attitudes	0.6736	0.5954	1	0.3901	0.4680	0.0486	0.2748	0.0213
Support from company for green meetings	0.2803	0.3756	0.3901	1	0.3699	-0.0519	0.2394	0.2026
PC1: Env. sustainability of conference & venue	0.4867	0.4865	0.4680	0.3699	1			
PC2: Conference attributes & career benefits	0.0405	0.1641	0.0486	-0.0519		1		
PC3: Time, distance, effort, & cost	0.1629	0.1374	0.2748	0.2394			1	
PC4: Destination image (safety, appeal)	0.0160	0.1866	0.0213	0.2026				1
Mean	35.6045	15.0149	22.8731	5.8209	(For factors derived from PC analysis, Mean = 0 and SD = 1.0)			
Std. dev.	6.3873	2.8310	4.8812	1.8832				

Values in bold are Pearson correlations different from 0 with a significance level alpha=0.05

Table 4
Step-wise multiple regression results

	F1: Environmental sustainability of conference & venue	F2: Conference attributes & career benefits	F3: Time, distance, effort, & cost	F4: Destination Image (safety, appeal)
Model fit:				
R ²	0.3223	0.0269	0.0755	0.0411
F	20.6039	3.6537	10.7843	5.6512
Pr > F	< 0.0001	0.0581	0.0013	0.0189
Predictors and β coefficients :				
Importance of green conferences	0.282**			
Importance of green venues	0.223 *	0.058†		
Individual's green attitudes				
Support from company for green meetings	0.207**		0.275***	0.203*

*p < .05; **p < .01; ***p < .001; † p = 0.0581

The key results of the four step-wise multiple regression analyses are reported in Table 4 and revealed the following for this population of German conference attendees:

- Considerations surrounding environmental sustainability of conferences and venues was impacted significantly (F (3, 130)=20.6, p<.001, R2=.322) by the (perceived) importance of green conferences (β =.282), the (perceived) importance of green venues (β =.223), and company support for green meetings (β =.207). Surprisingly, the step-wise regression analysis eliminated individual's green attitudes and behavior as a significant variable impacting German attendees' considerations for environmental sustainability.

- Considerations about conference attributes (e.g., the speakers, programme, and content) and the benefits that accrue to one's career (e.g., networking opportunities and professional advancement) was only marginally modeled by the set of four predictor variables ($F(1, 132)=3.654$, $p=.058$, $R^2=.027$). Only (perceived) importance of green venues ($\beta=.058$, $t=1.911$, $p=.058$) showed marginal degree of impact on German attendees' decision to attend conferences. In general, however, none of the four environmental interventions could be said to impact greatly in changing the importance of this type of consideration.
- The importance of green conferences, green venues, and company support for green meetings were not significant at all in influencing German attendees consideration of time, distance, and cost when deciding to attend conferences ($F(1, 132)=10.78$, $p=.0013$, $R^2=.075$). For this particular consideration, only an individual's green attitudes (and behavior) exhibited significant impact ($\beta=.275$) upon considerations of time, distance, and cost.
- When it comes to considerations regarding the destination's attractiveness, image, and perceived safety and security, only company support for green meetings proved instrumental ($\beta=.203$) overall in influencing this type of consideration ($F(1, 132)=5.65$, $p=.0189$, $R^2=.041$).

DISCUSSION

The aforementioned results reveal that, despite conference attendees becoming generally more socially responsible and rating green attributes to be important (Lee et al, 2013), such benevolent considerations do not take primacy in the decision to attend conferences, at least in the sample of German conference attendees that this study examined.

The 'hard' factors surrounding conference attributes (e.g., the programme, content, speakers) and the benefits they confer to attendees' career advancement and networking opportunities remain the paramount and decisive considerations when attending a conference. Furthermore, it appears that such 'hard' factors are unalterable by any of the four environmentally sustainable interventions examined (i.e., increasing the perceived importance of green conferences, green venues; increasing individual attitudes, beliefs, and practices about green behavior; and increasing company support for green conferences). It appears that greening conferences and venues remain independent of and compartmentalized from the more self-serving considerations when attending conferences. However, the fact that the organisers' greening of conferences is supported by delegates shows that there is no outright rejection of environmental sustainability in conferences. It might be assumed that a phenomenon which has already appeared in several studies of tourism can be taken as an explanation: Consumers often behave differently in other surroundings by allowing themselves to escape the daily patterns (Barr et al. 2001; Prillwitz and Barr 2011). Thus, environmental sustainability patterns are covered by the mentioned 'hard' factors which are more important for delegates in that situation.

A closer examination of the raw median ratings of the importance of green attributes from the sample of German conference attendees in this study further elaborates on the aforementioned result. Table 5 reflects the general lack of willingness of German conference attendees to actively contribute to or spend time on sustainability especially if this is accompanied with personal restrictions (e.g. travel choice). These results support the statement that the general interest in conference sustainability remains low (Mykletun et al. 2014) and that the majority is not willing to inform themselves about the degree of greening of a conference. In studies about purchasing behaviour this phenomenon is explained by a

simple lack of time (Leire and Thidell 2005; Liobikiené et al. 2016). However it needs to be said that in general the majority (46.27% / 62) of delegates have a positive attitude towards green conferences, as their opinion was that a green conference is not accompanied by restrictions and therefore it is not true that a green conference can not reach the scope of a non-environmentally friendly conference. Nevertheless, the knowledge about greening is limited and an evaluation of attributes seems difficult as almost the same percentage (41.79% / 56) replied that they do not know if a green conference is accompanied with restrictions in scope and quality. This can be related to the fact that in Germany sustainability is a current topic but in politics the main emphasis has been put on economic or social sustainability whereas environmental sustainability has not arrived yet with all its facets in daily life (Kröger 2015).

Table 5
DESCRIPTIVE STATISTICS IMPORTANCE OF GREEN ATTRIBUTES FOR CONFERENCE

Green attributes for conferences	Median	s.d.
Hotels in walking distance	4.0	0.975
Organisers should green conference	4.0	0.962
Can go without conference bag	4.0	1.051
Greening cost should be incorporated in fee	4.0	1.095
Travel by train	3.5	1.140
Inform myself about the degree of greening in advance	2.0	1.136
Use car sharing	2.0	1.207

There is some cause for optimism in that three of the four considerations examined showed susceptibility to being influenced by environmental interventions, with estimates showing that attendees' considerations regarding the environmental sustainability of conferences and venues can be increased from .142 to .324 on the raw 5-point influence scale if a corresponding unit change in company support and perceived importance of green conferences and venues is achieved. As a positive side effect reasons of time, cost or distance can automatically lead to a greener behavior – a result which can interact with the factor that an individual's green attitude can enhance an attendee's consideration of time, cost, and distance when deciding upon a conference.

Finally, the findings show that an attendee's consideration of a destination's image, attractiveness, and safety can be influenced by company support for green conferences, which suggests that organizations—through their support for sustainable conferences—can help shape attendees' considerations of how attractive a destination can be when attending conferences. The research findings suggest that it is essential to use delegates' positive fundamental attitude towards greening a conference. It is important to carefully implement green alternatives without creating the impression that something is missing. The aim should be that delegates start to consider a green conference product as something normal because they are not used to something else anymore. As environmental sustainability becomes more and more important in daily life in Germany (DESTATIS 2014; Federal Environment Ministry 2014), greening conferences should be one part of this movement and should not offer an opportunity to escape the daily patterns (Prillwitz and Barr 2011). Furthermore, the “embryonic state” of conference sustainability (Merrilees and Marles 2011, p. 367) should be improved. Conference sustainability is often just implemented in order to do ‘something’ but not anchored as a long-time strategy. Thus, it cannot be communicated effectively and credible and will not increase the degree of importance of sustainability on the side of the delegate.

REFERENCES

- Abbey, J. R. and Link, C. K., 1994. The Convention and Meetings Sector: Its Operation and Research Needs. In: Ritchie, J.R.B. and Goeldner, C., eds. *Travel, Tourism and Hospitality Research: A Handbook for Managers and Researchers*. New York: John Wiley.
- Ajzen, I., 1985. From intentions to actions: a theory of planned behaviour. In: Kuhl, J., and Beckman, J., eds. *Action control: From cognition to behaviour* [online], Heidelberg: Springer, 11-39.
- Ajzen, I., 2011. The theory of planned behaviour: Reactions and reflections. *Psychology & Health* [online], 26 (9), 1113-1127.
- Armitage, C. J. and Conner, M., 2001. Efficacy of the theory of planned behaviour: a metaanalytic review. *British Journal of Social Psychology* [online], 40 (4), 471-499.
- Arvola, A., Vassallo, M., Dean, M., Lampila, P., Saba, A., Lähteenmäki, L. and Shepherd, R., 2008. Research Report: Predicting intentions to purchase organic food: The role of affective and moral attitudes in the Theory of Planned Behaviour. *Appetite* [online], 50, 443-454.
- Barr, S., Gilg, A.W. and Ford, N.J., 2001. A conceptual framework for understanding and analysing attitudes towards household waste management. *Environment and Planning A* [online], 33, 2025–2048.
- DESTATIS – Federal Statistical Office, 2014. Sustainable development in Germany – Indicator Report 2014 [online]. Translated by i7646023. Wiesbaden: DESTATIS.
- Evans, M., Jamal, A. and Foxall, G., 2009. *Consumer Behaviour* [online]. 2nd edition. Chichester: Wiley.
- Falassi, A. (1987). *Festival: Definition and morphology* Time out of Time: Essays on the Festival (pp. 1-10). Albuquerque, New Mexico: University of New Mexico Press.
- FAMAB, 2016. Sustainability [online]. Rheda-Wiedenbrück: FAMAB. Available from: <http://famab.de/famab/nachhaltigkeit> [Accessed 18 May 2016].
- Federal Environment Ministry, 2014. Environmental awareness in Germany 2014 – Results of a representative poll of citizens [online]. Translated by i7646023. Berlin: Federal Environment Ministry.
- Fink, K., 2016. Imex/Conventions: Finger always on the pulse. *Trade Fairs International – The International Trade Fair Magazine* [online], 02/2016.
- Fishbein, M. and Ajzen, I., 1975. *Belief, attitude, intention and behavior: An introduction to theory and research* [online]. Reading: Addison-Wesley.
- Geraerts, E., Bernstein, D., Merckelbach, H., Linders, C., Raymaekers, L. and Loftus, E., 2008. Lasting False Beliefs and Their Behavioral Consequences. *Psychological Science* [online], 19 (8), 749-753.

German Convention Bureau (GCB), 2016b. Green Meetings made in Germany [online]. Frankfurt: German Convention Bureau. Available from: <http://www.gcb.de/> [Accessed 16 May 2016].

German Convention Bureau (GCB), 2016c. The GCB Sustainability Consultant Seminar [online]. Translated by i7646023. Frankfurt: German Convention Bureau. Available from: <http://www.gcb.de/> [Accessed 16 May 2016].

German Convention Bureau (GCB) and European Association of Event-Centres (EVVC), 2016a. Fairpflichtet – Sustainability Code of the German Event Industry [online]. Translated by i7646023. Frankfurt: German Convention Bureau and European Association of Event-Centres. Available from: <http://www.fairpflichtet.de/de/home/> [Accessed 16 May 2016].

German Sustainable Building Council (DGNB), 2016a. The DGNB Criteria [online]. Available from: <http://www.dgnb-system.de/en/system/criteria/core14/> [Accessed 18 May 2016].

Goldblatt, S., 2012. The complete guide to greener meetings and events. New Jersey: John Wiley.

Green Globe, 2016a. Membership [online]. Redondo Beach: Green Globe. Available from: <http://greenglobe.com/germany/membership/> [Accessed 18 May 2016].

Han, H., 2014. The norm activation model and theory-broadening: Individuals' decisionmaking on environmentally-responsible convention attendance. *Journal of Environmental Psychology* [online], 40, 462-471.

Han, H. and Hwang, J., 2016. What motivates delegates' conservation behaviors while attending a convention? *Journal Of Travel And Tourism Marketing* [online], 1-17.

Heerwegh, D., Vanhove, T., Matthijs, K. and Loosveldt, G., 2005. The Effect of Personalization on Response Rates and Data Quality in Web Surveys. *International Journal Of Social Research Methodology: Theory & Practice* [online], 8 (2), 85-99.

Hornig, J.-S., Su, C.-S. and So, S.A., 2013. Segmenting Food Festival Visitors: Applying the Theory of Planned Behavior and Lifestyle. *Journal of Convention & Event Tourism* [online], 14, 193-216.

International Organization for Standardization (ISO), 2016a. ISO 20121 - Sustainable events [online]. Geneva: International Organization for Standardization. Available from: <http://www.iso.org/iso/iso20121> [Accessed 18 May 2016].

Kröger, M., 2015. Sustainable economising: Germany only in the sixth place. *Spiegel Online* [online], 8 September 2015. Available from: <http://www.spiegel.de> [Accessed 14 May 2016].

Leach, M., Liu, A. and Winsor, R., 2008. The impact of attitudes, word-of-mouth, and value congruence on conference participation: A comparison of attending and non-attending organizational members. *Journal Of Hospitality And Leisure Marketing* [online], 16 (3), 246-269.

Lee, M., and Back, K., 2005. A Review of Convention and Meeting Management Research 1990-2003: Identifying Statistical Methods and Subject Areas. *Journal of Convention and Event Tourism* [online], 7 (2), 1-12.

Lee, W., Barber, T. and Tyrrell, T., 2013. Green attendee's evaluation of green attributes at the convention centre: using importance-performance analysis. *Anatolia-An International Journal of Tourism and Hospitality Research* [online], 24 (2), 221-240.

Leire, C. and Thidell, Å., 2005. Product-related environmental information to guide consumer purchases - a review and analysis of research on perceptions, understanding and use among Nordic consumers', *Journal Of Cleaner Production* [online], 13, 1061-1070.

Liobikienė, G., Mandravickaitė, J. and Bernatoniene, J., 2016. Theory of planned behaviour approach to understand the green purchasing behavior in the EU: A cross-cultural study. *Ecological Economics* [online], 125, 38-46.

Lortie, J. and Castogiovanni, G., 2015. The theory of planned behavior in entrepreneurship research: What we know and future directions. *International Entrepreneurship And Management Journal* [online], 11 (4), 935-957.

Mair, J., and Thompson, K., 2009. The UK association conference attendance decisionmaking process. *Tourism Management* [online], 30, 400-409.

MalekMohammadi, A. and Mohamed, B. 2010. Convention Decision Making Modelling. *International Journal of Trade, Economics and Finance* [online], 1 (1), 54-57.

MalekMohammadi, A. and Mohamed, B., 2011. Applying consumer behaviour theory and grand models to attendees behaviour in conference industry. *Tourism & Management Studies* [online], 1, 151-159.

Merrilees, B. and Marles, K., 2011. Green Business Events: Profiling through a case study. *Event Management* [online], 15 (4), 361-372.

Moderer, A., Bloth, T. and Holbach, V., 2012. Green Meetings by the example of the Congress Centre Mainz. Translated by i7646023. In: Schreiber, M.-T., ed. *Congresses, Conferences and Events – Potentials, strategies and trends in the events industry* [online]. Translated by i7646023. München: Oldenbourg Wissenschaftsverlag, 187-194.

Moutinho, L., 1987. Consumer Behaviour in Tourism. *European Journal of Marketing* [online], 21 (10), 5-44.

Mykletun, R., Bartkeviciute, M. and Puchkova, Y., 2014. Green Meetings – Do They Matter to their Closest Stakeholders? *Scandinavian Journal Of Hospitality & Tourism* [online], 14 (3), 211-233.

Oppermann, M. and Chon, K., 1997. Convention participation decision-making process. *Annals Of Tourism Research* [online], 24 (1), 178-191.

Page, S. J., & Connell, J. (Eds.). (2011). *The Routledge Handbook of Events*. Abingdon, UK: Routledge.

Perugini, M. and Bagozzi, R., 2001. The role of desires and anticipated emotions in goal-directed behaviours: Broadening and deepening the theory of planned behaviour. *British Journal Of Social Psychology* [online], 40 (1), 79-98.

Planing, P., 2014. *Innovation Acceptance: The Case Of Advanced Driver-Assistance Systems* [online]. Wiesbaden: Springer Fachmedien.

Prayag, G., Hosany, S., Nunkoo, R. and Alders, T., 2013. London residents' support for the 2012 Olympic Games: The mediating effect of overall attitude. *Tourism Management* [online], 36, 629-640.

Prillwitz, J. and Barr, S., 2011. Moving towards sustainability? Mobility styles, attitudes and individual travel behaviour. *Journal Of Transport Geography* [online], 19, 1590-1600.

Rittichainuwat, B. N., Beck, J. and Lalopa, J., 2001. Understanding Motivations, Inhibitors, and Facilitators of Association Members in Attending International Conferences. *Journal of Convention & Exhibition Management* [online], 3 (3), 45-62.

Roese, N., and Sherman, J., 2007. Expectancy. In: Kruglanski, A.W. and Higgins, E.T. eds. *Social psychology: handbook of basic principles* [online]. 2nd edition. New York: Guilford Press.

Rogers, T., 2008. *Conferences And Conventions: A Global Industry* [online]. 2nd edition. Oxford: Butterworth-Heinemann.

Schiffman, L.G. and Kanuk, L.L., 2004. *Consumer Behavior*. 8th edition. Upper Saddle River: Pearson Education International.

Severt, D., Wang, Y., Chen, P. and Breiter, D., 2007. Examining the motivation, perceived performance, and behavioral intentions of convention attendees: Evidence from a regional conference. *Tourism Management* [online], 28 (2), 399-408.

Sheeran, P., Gollwitzer, P. M. and Bargh, J. A., 2013. Nonconscious processes and health. *Health Psychology* [online], 32, 460-473.

Smith-Christensen, C., 2009. Sustainability as a concept within events. In: Raj, R. and Musgrave, J., eds. *Event Management And Sustainability* [online]. Cambridge: CABI, 22-31.

Sniehotta, F., Presseau, J. and Araujo-Soares, V., 2014. Time to retire the theory of planned behaviour. *Health Psychology Review* [online], 8 (1), 1-7.

Song, H.J., Lee, C.K, Kang, S.K. and Boo, S., 2012. The effect of environmentally friendly perceptions on festival visitor's decision-making process using an extended model of goal-directed behavior. *Tourism Management* [online], 33, 1417-1428.

Targeted News Service, 2015. IAEE, PCMA and The Experience Institute Team Up on Comprehensive Study of the Behaviors Behind the Decision to Attend. Targeted News Service [online], 6 February 2015. Available from: <http://go.galegroup.com> [Accessed 2 May 2016].

Thomson, A., 2009. The Australian Centre for Event Management (ACEM) 5th International Event Management Research Conference. *Anatolia: An International Journal Of Tourism & Hospitality Research* [online], 20 (2), 474-478.

Trespalacios, J. and Perkins, R., 2016. Effects of Personalization and Invitation Email Length on Web-Based Survey Response Rates. *Techtrends* [online], 1-6.

Var, T., Cesario, F. and Mauser, G., 1985. Convention Tourism Modeling. *Tourism Management* [online], 6 (3), 195-204.

Wagner, A., 2014. It is not about renunciation. Translated by i7646023. *Tw Tagungswirtschaft – Special Edition ‘Green Meetings’* [online], 6-12.

Whitfield, J., Dioko, L. and Webber, D., 2014a. Scoring environmental credentials: a review of UK conference and meetings venues using GREENER VENUE framework. *Journal of Sustainable Tourism* [online], 22 (2), 299-318.

Whitfield, J., Dioko, L., Webber, D., and Zhang, L., 2014b. Attracting Convention and Exhibition Attendance to Complex MICE Venues: Emerging Data from Macao. *International Journal Of Tourism Research* [online], 16 (2), 169-179.

Wood, E. H. (2009). An Impact Evaluation Framework: Local Government Community Festivals. *Event Management*, 12(3-4), 171-185.

Yoo, J. and Chon, K., 2008. Factors Affecting Convention Participation Decision-Making: Developing a Measurement Scale. *Journal Of Travel Research* [online], 47 (1), 113-122.

Yoo, J. and Chon, K., 2010. Temporal changes in factors affecting convention participation decision. *International Journal Of Contemporary Hospitality Management* [online], 22 (1), 103-120.

Yoo, J. and Zhao, X., 2010. Revisiting determinants of convention participation decision making. *Journal Of Travel And Tourism Marketing* [online], 27 (2), 179-192.

Zhang, H., Leung, V. and Qu, H., 2007. A refined model of factors affecting convention participation decision-making. *Tourism Management* [online], 28 (4), 1123-1127.

HOLIDAY EFFECTS ON THE STOCK PRICE OF THE AMUSEMENT PARK AND ATTRACTIONS INDUSTRY IN THE UNITED STATES

CHIA-NING CHIU

National Ilan University, Taiwan

ABSTRACT

This study offers further evidence of the holiday effects on the stock price excess returns and volatility and additional insight into the impact on the amusement park and attractions industry in the United States. The GARCH model and dummy variables are adopted by this research to investigate pre- and post-holiday excess returns and volatility. The major empirical results are: first, excess returns and volatility do exist on the stock price of the amusement parks and attractions industry. Second, the excess volatility rate is higher than excess returns on the holiday effects. Third, all significant excess volatility are negative and the excess volatility often occurs in pre-holidays. Finally, different holiday's effects exist in the different amusement parks and attractions.

Keywords: holiday effects, excess returns, excess volatility, GARCH model

INTRODUCTION

According to the statistical figures from the International Association of Amusement Parks and Attractions (IAAPA), a total nationwide economic impact of \$219 billion in 2011 was generated from approximately 30,000 attractions, including amusement and theme parks, water parks, aquariums, zoos, family-oriented entertainment centers, science centers, museums, resorts, etc. The amusement and theme parks industry is a leader industry to create tons of non-exportable jobs. This industry not only directly creates more than 1.3 million jobs, but also indirectly offers 1 million jobs, which means that the whole industry generates a total job influence of 2.3 million. Except for full time jobs, the amusement and theme parks also provide more than 100,000 year-round and 500,000 seasonal employees with jobs. The report provided by Global Industry Analysts, Inc. predicts that global market for amusement and theme parks can hit US \$44.3 billion prior to 2020, because the global economy has been recovering, the middle class population in emerging countries has been growing, and international tourists' arrivals and travel and leisure outlay have been increasing. The report also forecasts that the coming retired baby boomers will become potential and lucrative consumer clusters for amusement and theme parks or entertainment/ leisure-related industry.

Although Asia-Pacific amusement and theme parks' market now is the fastest growing market with a CAGR of 12.2 %, the United States still represents the largest amusement and theme parks market in the world. Amusement and theme parks are a perfect holiday destination not only for children but also for adults. Furthermore, according to 2011 Amusement Park State of the Industry survey from IAAPA, 25 percent of Americans surveyed went to a theme or amusement park within the last 12 months, and around 43 % of Americans answered that they would plan to re-visit again within the next 12 months. Therefore, amusement and theme parks are popular holidays' destinations, and the ticket sales will be increased and influenced by holiday events. Heo and Lee (2009) summarized the features of the amusement and theme parks are high fixed cost, low variable cost, perishable inventory, etc. In this situation, a holiday event is a vital timing for ticket sales to maximize revenues.

In the United States, there are many holidays. As these holidays approach, amusement and theme parks hold many special celebrations, parades, and performances to welcome visitors with fabulous memories. Moreover, holidays not only have impacts on an amusement and theme park's revenue growth but also influence the stock's movements. Due to characteristics of amusement and theme parks, many marketing and business strategies can be utilized in holidays. Holidays not only affect the number of amusement and theme's visitors but also decide the price making of amusement park tickets with discounts. Furthermore, the number of visitors of amusement parks can also promote restaurants' sales, hotel guest rooms' revenues, souvenirs sales of amusement parks during holidays.

In the last few decades, many scholars have conducted research studies on the presence of calendar anomalies in economic and financial markets, which is against the efficient market hypothesis (EMH) supported by Fama (1970). Since Fama (1970) proposed the Efficient Markets Hypothesis (EMH), many related research studies have been widely conducted. However, behavioural finance scholars have not agreed because EHM cannot completely explain the holiday effects/ calendar effect such as Monday effect, January effect, and so on. Therefore, according to the theory of behaviour finance, the purpose of this study is to examine the excess returns and volatility in the amusement park ad attractions industry before and after the holiday in the United States. This study not only offers further evidence of the holiday effects on the stock price with a higher excess return and volatility, but also presents additional and different perspectives on the holiday effect phenomenon in the amusement park and attractions industry in the United States.

LITERATURE REVIEW

Since Disneyland first opened in California in 1955, the global amusement and theme park industry has been growing rapidly. Milman, Li, Wang, and Yu (2012) mentioned that there are roughly 189.1 million people had visited the top 25 amusement and theme parks worldwide by 2010. Alexander, MacLaren, O'Gorman, and White (2012) alluded to the theme park industry worldwide now with a growth mode, so it attracts thousands of people each single year. Thus, Dong and Siu (2013) stated that "the tourism industry is a major pillar of the world economy, and in some economies theme parks make a major contribution." For example, according to the statistical figures from Dong and Siu (2013), Disneyland Resort Hong Kong and Hong Kong Ocean Park, two major amusement parks, generate roughly US\$2 billion in 2011; this amount equals to around 0.9% of GDP in Hong Kong.

Anomalies on holiday events in the US stock market have been widely examined. For example, Lakonishok and Smidt (1988) examine the evidence of persistently abnormal returns around the turn of the week, the month, the year, and holidays. They also find that "the preholiday rate of return is 23 times larger than the regular daily rate of return, and holidays account for about 50 percent of the price increase in the DJIA." Pettengill (1989) documents the abnormal return patterns for stock market as holidays approach. The findings show that returns for trading days right prior to holidays are abnormally high. Ariel (1990) explores high stock returns before holidays. The results exhibit that "Over one third of the total return accruing to the market portfolio over the 1963-1982 period was earned on the eight trading days which each year fall before holiday market closings." Kim and Park (1994) examines the holiday effect on stock returns and provides additional insight in to the effects.

They found that abnormally high returns not only occur on the trading day before the holiday in all three major stock market in the United States: the NYSE, AMEX, and NASDAQ, but also exhibit in the United Kingdom and Japanese stock markets.

The holiday effect also has been examined outside of the United States. For example, Ziemba (1991) examined evidence on seasonal regularities in stock returns on the Tokyo Stock Exchange (TSE). The results from this study show that turn-of-the-month and first-half-of-the-month, turn-of-the-year, holiday effects on the TSE. Cadsby and Ratner (1992) examined the pre-holiday and turn-of-month effects on stock returns. They found that turn-of-month effects are statistically significant on stock returns in the UK, Switzerland, West Germany, Canada, and Australia. The pre-holiday effects did exhibit in Hong Kong, Japan, Canada, and Australia. Booth, Kallunki, and Martikainen (2001) employed Finnish data to examine the liquidity on the turn-of-month effects on stock returns. Their findings showed that there are higher returns on the turn-of-month than during the rest of the month. In addition, the liquidity increases internal trading, which means that the turn-of-month effects occur with the trading venue. Kunkel, Compton, and Beyer (2003) investigated 19 country stock market indexes on the turn-of-the-month effects. They found that there are 87% of the month return from the 4-day the turn-of-the month in the stock markets of 15 countries where holiday effects occurs. Additionally, these 15 countries account for 77% of the foreign market capitalization value. Gama and Vieira (2013) analyzed stock market behaviour to have further evidence on the holiday effects. Their results revealed a statistically significant negative liquidity effect and significant positive price effect during the Portuguese- specific national holidays that are associated with a typical trading day.

Milman (2010) thought amusement and theme parks are a fairly new concept of tourist attractions and tries to create amazing atmosphere of another relaxing and interesting place and time. The theme park industry has grown globally in recent decades and in general, global amusement and theme parks host over three million per year, indicating that this market is huge and continues growing up. As mentioned above, amusement and theme park industry is not only one of important industries for the economy, but also play a vital role for the leisure, recreation, tourism and hospitality industry. However, so far no one examines holiday effects on the amusement and theme park industry to determine how holidays or what degrees of holidays can bolster the amusement and theme park industry. This research would like to bridge this gap not only to examine the theory of behavioural finance but also to explore the holiday effects on the amusement and theme park industry.

DATA AND METHODOLOGY

The amusement and theme park companies this study chooses are all listed on the NYSE: Cedar Fair Entertainment Company (FUN), The Walt Disney Company (DIS), SeaWorld Parks & Entertainment (SEAS), and Six Flags (SIX). This study computes daily stock price returns for these four companies from the first trading day of 2014 to the last trading day of 2016. Standard & Poor's 500 Index (S&P 500) is adopted by this study as well.

The holidays in this study include the United States public holidays (New Year's Day, Martin Luther King Day, President's Day, Memorial Day, Independent Day, Labor Day, Columbus Day, Veterans Day, Thanksgiving Day, Christmas Day) and some non-public holidays (Valentine's Day, St. Patrick's Day, Easter Sunday, Mother's Day, Father's Day, Halloween, Election Day). Some public holidays are on Mondays such as Martin Luther King day, president's day, memorial day, labor day, and Columbus day; due to these public holidays

falling on Monday, people have three days off, which is a long weekend. In the United States Thanksgiving is always on Thursday, and the adjacent Friday, Black Friday, is made into a non-working day at some companies. For non-public holiday, some holidays are on specific

dates such as Valentine's Day, St. Patrick's Day, and Halloween. However, some holidays are always on Sunday such as Easter Sunday, Mother's day, and Father's day.

This study uses time series of daily stock returns for each company and Standard & Poor's 500 Index so it is important to know whether the time series are stationary or nonstationary; otherwise, spurious regressions might occur when nonstationary series are adopted in regression analysis, which means there are not genuine results from unrelated data. Therefore, this study employs Unit Root Tests to determine whether the series are stationary or nonstationary. The Augmented Dickey-Fuller test with three variations is applied in this study. The Augmented Dickey-Fuller (ADF) test 1 is no constant and no trend ($\Delta y_t = \gamma y_{t-1} + v_t$), test 2 is with constant but no trend ($\Delta y_t = \alpha + \gamma y_{t-1} + v_t$), and test 3 is with constant and with trend ($\Delta y_t = \alpha + \lambda t + \gamma y_{t-1} + v_t$). Then, the hypotheses are $H_0: \gamma = 0$ and $H_1: \gamma < 0$. In short, if $\gamma = 0$, the null hypothesis cannot be rejected, which means the series is nonstationary; otherwise, the null hypothesis can be rejected so the series is stationary.

After adopting unit root test, the Generalized Auto-Regressive Conditional Heteroscedasticity (GARCH) model is built for this study. The GARCH model offers a more flexible framework to capture various dynamic structures of conditional variance. This research takes many studies in the literature regarding holiday effects into consideration and defines pre-holiday as the day prior to the holiday and post-holiday as the day after the holiday. The holiday dummy variables are added into the equation:

$$R_t = \alpha + \sum_{j=1}^n \gamma_{j,t} D_{j,t} + \varepsilon_t \quad (1)$$

$$\varepsilon_t \sim N(0, \sigma_t^2), \quad (2)$$

where R_t is the difference in the stock return of the listed amusement and theme park companies and the returns of the S&P 500 index, $D_{j,t}$ is the dummy variable of the holiday, $\gamma_{j,t}$ shows the abnormal return that happens before and after the holiday, and ε_t is white noise. Likewise, the dummy variables are added into the variance equation:

$$\sigma_t^2 = c + \sum_{k=1}^q \alpha_k \varepsilon_{t-k}^2 + \sum_{i=1}^p \beta_i \sigma_{t-i}^2 + \sum_{j=1}^n \delta_{j,t} D_{j,t}, \quad (3)$$

where $\sum_{k=1}^q \alpha_k \varepsilon_{t-k}^2$ is the ARCH effect, $\sum_{i=1}^p \beta_i \sigma_{t-i}^2$ is the GARCH effect, $\delta_{j,t}$ represents the event-induced variance that occurs before and after the holiday, and n is the number of holidays. As mentioned before, γ is the excess return in the mean equation and δ is the excess return in the variance equation. The significance of them indicates which one has the holiday effect.

EMPIRICAL RESULTS

Table 1 shows that there is an 11.39% significant effect for excess return rates and 22.22% significant effect for excess volatility rate, including pre-holidays and post-holidays. This indicates that excess volatility rate is higher than excess returns for the holiday effects. In addition, Table 2 exhibits that there is a 5.83% positive and significant effect while 5.56% negative and significant impact. Both of these rates are not high. However, for excess

volatility, there is no positive and significant effect but there is a 22.22% negative and significant effect, which means all significant excess volatilities are negative. For the excess returns, there is an 8.33% significant rate for pre-holiday but post-holiday receives 14.44%. This implies that the excess return rate that exists in post-holidays is higher than the rate in

pre-holiday. However, for the excess volatility, pre-holiday accounts for 37.22% while post-holiday has 7.22%. This indicates that the excess volatility rate occurs in pre-holiday is way higher than the rate in post-holiday.

Table 1
EXCESS RETURNS AND VOLATILITY OF THE HOLIDAYS

Holiday	Excess Return				Excess Volatility			
	N of Sig	Rate	N of Insig	Total	N of Sig	Rate	N of Insig	Total
Pre-Martin	4	33.33%	8	12	4	33.33%	8	12
Post-Martin	4	33.33%	8	12	2	16.67%	10	12
Pre-Valentine	1	8.33%	11	12	5	41.67%	7	12
Post-Valentine	2	16.67%	10	12	1	8.33%	11	12
Pre-Patrick	1	8.33%	11	12	4	33.33%	8	12
Post-Patrick	2	16.67%	10	12	2	16.67%	10	12
Pre-Easter	0	0.00%	12	12	4	33.33%	8	12
Post-Easter	0	0.00%	12	12	0	0.00%	12	12
Pre-Mother	2	16.67%	10	12	4	33.33%	8	12
Post-Mother	3	25.00%	9	12	0	0.00%	12	12
Pre-Memorial	0	0.00%	12	12	2	16.67%	10	12
Post-Memorial	1	8.33%	11	12	1	8.33%	11	12
Pre-Father	0	0.00%	12	12	8	66.67%	4	12
Post-Father	2	16.67%	10	12	0	0.00%	12	12
Pre-Independent	0	0.00%	12	12	8	66.67%	4	12
Post-Independent	1	8.33%	11	12	2	16.67%	10	12
Pre-Labour	2	16.67%	10	12	6	50.00%	6	12
Post-Labour	1	8.33%	11	12	0	0.00%	12	12
Pre-Columbus	1	8.33%	11	12	7	58.33%	5	12
Post-Columbus	1	8.33%	11	12	1	8.33%	11	12
Pre-Halloween	0	0.00%	12	12	4	33.33%	8	12
Post-Halloween	1	8.33%	11	12	1	8.33%	11	12
Pre-Veterans	2	16.67%	10	12	4	33.33%	8	12
Post-Veterans	3	25.00%	9	12	0	0.00%	12	12
Pre-Thanksgiving	0	0.00%	12	12	1	8.33%	11	12
Post-Thanksgiving	3	25.00%	9	12	1	8.33%	11	12
Pre-Christmas	2	16.67%	10	12	5	41.67%	7	12
Post-Christmas	0	0.00%	12	12	0	0.00%	12	12
Pre-New Year Day	0	0.00%	12	12	1	8.33%	11	12
Post-New Year Day	2	16.67%	10	12	2	16.67%	10	12
Total	41	11.39%	319	360	80	22.22%	280	360

Table 2
THE SIGNIFICANCE OF PRE- AND POST-HOLIDAY BY POSITIVE AND NEGATIVE

		Pre-holiday	Post-holiday
Significate rate of ER	Positive	11/15	10/26
	Negative	4/15	16/26
Significate rate of EV	Positive	0/67	0/13
	Negative	67/67	13/13

DISCUSSION

This study contributes to both academia and industry. For the academia, this study can be examined by the theory of behavioural finance and can explain the holiday effects for amusement parks and attractions industry. The findings of this study also have crucial managerial implications in the industry because more people now take their days off than in the past. People realize leisure and recreation can enhance their quality of life. Therefore, taking part in leisure activities such as going to amusement parks or attractions is part of people's lives, especially in holidays with their family and children. Hence, it is important to examine what extent and how holiday effect phenomenon has an impact on the amusement parks and attractions industry. Additionally, through this study, these amusement parks companies can develop better marketing strategies and adjust business models for the specific dates to maximize their sales and also increase profits. Furthermore, this study can benefit the

shareholders of these amusement park companies because investors can determine the time to purchase or sell the stocks to earn money.

There are some limitations in this study. The companies that this study adopts are all publicly traded companies. The number of the publicly traded companies in the amusement parks and attractions industry is less than the number of publicly traded firms in other industries. Therefore, the sample of data collection in the amusement parks and attractions is not that big. Moreover, this study focuses on the holiday impacts on the stock price of the amusement parks and attractions industry and to determine whether different holidays can have different effects on the businesses of the amusement parks and attractions. However, this study does not consider whether different scales of companies with different revenue growth and financial situations. For the research implications, this study reveals that the “calendar effects” happen, which means that stock returns and volatilities can be predicted for certain days of the week, days of the month, or certain holidays of the year. In addition, this study examines the theory of behavioural finance; behavioural finance can bridge the knowledge gap left by the traditional financial and economic theory such as Efficient Market Hypothesis (EMH) that cannot explain an abnormal phenomenon in the stock market.

The examination of the holiday impacts on amusement parks and attractions is a novel idea because for the companies, they can realize what extent or how the holidays can bring the maximization of revenues and for the investors, they can know the right time to buy or sell their stocks for maximizing their personal financial management. This study also provides a new and different insight into the entertainment industry through holiday effects/ events.

REFERENCES

- Alexander, M., MacLaren, A., O’Gorman, K., & White, C. (2012). Priority queues: Where social justice and equity collide. *Tourism Management*, 33(4), 875-884.
- Ali, F., Kim, W. G., Li, J., & Jeon, H. M. (2016). Make it delightful: Customers' experience, satisfaction and loyalty in Malaysian theme parks. *Journal of Destination Marketing & Management*.
- Ariel, R. A. (1990). High stock returns before holidays: Existence and evidence on possible causes. *The Journal of Finance*, 45(5), 1611-1626.
- Booth, G. G., Kallunki, J. P., & Martikainen, T. (2001). Liquidity and the turn-of-the-month effect: evidence from Finland. *Journal of International Financial Markets, Institutions and Money*, 11(2), 137-146.
- Cadsby, C. B., & Ratner, M. (1992). Turn-of-month and pre-holiday effects on stock returns: Some international evidence. *Journal of Banking & Finance*, 16(3), 497-509.
- Cao, X. L., Premachandra, I. M., Bhabra, G. S., & Tang, Y. P. (2009). Firm size and the pre-holiday effect in New Zealand. *International Research Journal of Finance and Economics*, 32, 171-187.
- Dong, P., & Siu, N. Y. M. (2013). Servicescape elements, customer predispositions and service experience: The case of theme park visitors. *Tourism Management*, 36, 541-551.

Fama, E. F. (1970). Efficient capital markets: A review of theory and empirical work. *The Journal of Finance*, 25(2), 383-417

Gama, P. M., & Vieira, E. F. (2013). Another look at the holiday effect. *Applied Financial Economics*, 23(20), 1623-1633.

Heo, C. Y., & Lee, S. (2009). Application of revenue management practices to the theme park industry. *International Journal of Hospitality Management*, 28(3), 446-453.

Kim, C. W., & Park, J. (1994). Holiday effects and stock returns: Further evidence. *Journal of Financial and Quantitative Analysis*, 29(1), 145-157.

Kunkel, R. A., Compton, W. S., & Beyer, S. (2003). The turn-of-the-month effect still lives: the international evidence. *International Review of Financial Analysis*, 12(2), 207-221.

Lakonishok, J., & Smidt, S. (1988). Are seasonal anomalies real? A ninety-year perspective. *The Review of Financial Studies*, 1(4), 403-425.

Ma, J., Gao, J., Scott, N., & Ding, P. (2013). Customer delight from theme park experiences: The antecedents of delight based on cognitive appraisal theory. *Annals of Tourism Research*, 42, 359-381.

Milman, A. (2010). The global theme park industry. *Worldwide Hospitality and Tourism Themes*, 2(3), 220-237.

Milman, A., Li, X., Wang, Y., & Yu, Q. (2012). Examining the guest experience in themed amusement parks: Preliminary evidence from China. *Journal of Vacation Marketing*, 18(4), 313-325.

Pettengill, G. N. (1989). Holiday closings and security returns. *Journal of Financial Research*, 12(1), 57-67.

Ziemba, W. T. (1991). Japanese security market regularities: Monthly, turn-of-the-month and year, holiday and golden week effects. *Japan and the World Economy*, 3(2), 119-146.

PARTICIPATING AND NON-PARTICIPATING RESIDENT PERCEPTIONS AND ATTITUDES TOWARDS MACAO'S DRUNKEN DRAGON FESTIVAL

SUH-HEE CHOI

Institute for Tourism Studies, Macao

UBALDINO SEQUEIRA COUTO

Institute for Tourism Studies, Macao

SHARIF SHAMS IMON

Institute for Tourism Studies, Macao

ABSTRACT

Highlighting the rapid transformation of traditional local cultural festivals in general and their touristification in particular, this study focuses on the residents' perceptions and attitudes towards such festivals by utilizing Macao's Drunken Dragon Festival as a case. Perceptions of cultural, economic, social, and environmental impacts and attitudes towards transformation of the original form of the festival were asked to both participants and non-participants of the festival. Commonality and differences in perceptions and attitudes towards the festivals were identified across two resident groups of participants and non-participants. The results show that the participants were more positive than non-participants about its cultural, social and environmental impacts, but not about economic impacts. Also, the former were more supportive about holding the performances in more diverse venues yet they were more rigid about holding the festival on the original date. The study implies that promoting the festivals would increase participation of different groups of people, thus improving its status as the one that represents Macao's culture.

Keywords: Macao, Drunken Dragon Festival, traditional cultural festival, resident, perception, attitude

INTRODUCTION

In recent years, residents are acknowledged as one primary stakeholder group in the management of traditional festivals in that they affect and are affected by the decision making of how to organize and celebrate the festivals (Andersson & Getz, 2008; Reid & Arcodia, 2002). Furthermore, recently, many festivals are undergoing transformation in the process of being promoted as tourist attractions and incorporating diverse participants to seek sustainable development. Accordingly, understanding the residents' perceptions of the festivals and how they think about the transformation would provide insight into pursuing viable and sustainable management of this sort of local traditional festivals.

This study features Macao's Drunken Dragon Festival as a case. Understanding this case provides important implications in diverse aspects. First, since this festival was designated as the National Intangible Heritage of the People's Republic of China in 2012, the festival has undergone the pressure of commercialization and touristification (Laing & Frost, 2014; S. Lee & Kim, 2014) not only by the governmental organizations such as Macao Government

Tourist Office but also by the main organizers such as Macao Fresh Fish and Commercial Association, an association for fishmongers in this region. Accordingly, clarifying the direction of how much to maintain its original form and how much to incorporate the demands for

commercialization and tourism incorporation have been set as important agendas in recent years. Second, the participation of this festival has been still limited. Therefore, understanding of the stakeholders' differentiated perceptions and attitudes based on their involvement would provide further insights into how to consider the residents' voice differently depending on their participation and involvement. The purpose of this study, therefore, is to explore the residents' differentiated perceptions and attitudes towards Drunken Dragon Festival by participation.

LITERATURE REVIEW

Drunken Dragon Festival

The Drunken Dragon Festival, which originated from Guangdong Province, is known to have been celebrated for the last 100 years, and it has been undergoing a drastic transition in the last few years. Traditionally, the festival has been held at Sam Kai Vui Kun (i.e., Kuan Tai Temple), Mercado Almirante Lacerda (i.e., Red Market), Complexo Municipal do Mercado de S. Domingos (i.e., St. Dominic's Market), and Mercado Municipal do Bairro Iao Hon (i.e., Iao Hon Market). Different legends with regards to the Drunken Dragon exist, but the common version entails an intoxicated Buddhist monk slaying a dragon whose blood fell into the river and was drunk by villagers and miraculously ended the plague affecting the region. Various elements of the festivals such as religious rituals, prayers and offerings, the Drunken Dragon Dance as well as longevity meal distribution have been visually identifiable in these cultural spaces. In addition to these festive elements, a procession follows in the neighborhood to mark the devotion and auspicious dedication of honoring the Drunken Dragon (Macao Temple Civilization, 2017). The longevity rice is an auspicious meal for festival participants to consume and/or to take home; it is widely understood particularly by the elderly that the longevity meal brings good health and diligence to those who consume and thus very popular among elderly or those with children and grandchildren.

In the last few years, this festival has experienced drastic changes. Professional photographers have been invited during the festivals for distribution of better-quality pictures and the enhancement of its popularity. Seminars and exhibitions have been uniquely organized in recent years. For example, recently, the period of the festival programmes has been extended to more than one day. In 2017, Drunken Dragon Festival was celebrated in association with International Museum Day with the title of "The Mobile Museum – Red Market X Drunken Dragon Festival". Exhibitions and seminars in addition to the performances were jointly organized in order to enhance its awareness (Macao Government Cultural Affairs Bureau, 2017). Most of the events held as a part of this festival was conducted in Cantonese, reflecting that non-Cantonese-speaking residents and tourists may have limited opportunities to participate in the festival.

Residents' Perceptions and Attitudes toward Traditional Festivals

Resident perceptions have been the main topic in understanding the thought of the primary stakeholder of a region and in seeking the direction to effectively and sustainably manage and organize the festival. There were efforts in developing tools to measure impacts caused by festivals and events (Small, Edwards, & Sheridan, 2005; Wood, 2005), but to date no such

tool is universally adopted for use. The contexts have been on regional development, tourism development, festivals and events, and heritage conservation, which are largely in line with important themes in event studies (Getz & Page, 2016). Previous studies on residents'

perceptions of event impacts have been largely focused on mega events (Ritchie, Shipway, & Cleeve, 2009).

Perception and attitude studies have scrutinized the residents' perceived impacts of the festivals mostly in cultural, economic, social, and environmental aspects. Increasingly, research has moved from an emphasis on economic impacts to social and environmental aspects (Mair & Whitford, 2013). Firstly, the perceived cultural impacts have focused on the residents' perceptions about the cultural role of the festivals in its society in term of cultural enrichment (del Barrio, Devesa, & Herrero, 2012). For example, multicultural festivals have been known for its role in manifesting cultural diversity in today's modern societies (I. S. Lee, Arcodia, & Lee, 2012). Secondly, the economic functions of festivals have been considered as one indicator of sustainable contribution of the festival to the region (Chhabra, Sills, & Cabbage, 2003). This is particularly important for eventful cities that rely heavily on festivals and events as important elements within its tourism portfolio such as Macao (Richards & Palmer, 2010). Even though Drunken Dragon Festival is not intended to be for-profit, as residents may witness the transformation of the festival, especially its external involvement and influx of tourists and non-resident participants, they may acknowledge the economic role of this community festival. Thirdly, the role of community festivals as the opportunity to meet the community members as well as those from different communities is generally acknowledged. For instance, some authors examined the role of festivals in building social capital (Wilks, 2011). The potential of cultural festivals in achieving positive social goals were explored extensively by a number of authors (Arcodia & Whitford, 2006; Richards, de Brito, & Wilks, 2013). Drunken Dragon Festival, as a traditional community festival, has been acknowledged as bringing community members to the festival venue, providing opportunities to meet different people. Last, festival impact studies have shown interest in the environmental impact of the festival, mostly focusing on the hygiene issues.

Festivals and events have been known for their role in transforming residents' attitudes and behavior (Mair & Laing, 2013). While it is important to maintain the integrity and authenticity of the Drunken Dragon Festival, intervention by the local authorities to commercialize the festival for a higher touristic appeal is inevitable. It is therefore important to understand how residents perceive the transformation of Drunken Dragon Festival, if any, which in the long-run will potentially influence its support or opposition to the commercialization of the festival for tourism means.

Involvement as a Grouping Variable

This study posits that those who are highly involved with the festival as organizers or as participants—those who attend the festival as longevity meal preparers and recipients, spectators of the rituals and dances, and the participant of the seminars and exhibitions—may have different perceptions and attitudes towards the festival than those who have low levels of involvement—those who may have heard yet have not participated in the festival, or those who have not participated in the festival recently.

METHODOLOGY

Two sets of data were collected with a gap of two years. The resident sample among those who participated in the Drunken Dragon Festival was collected on the date when the Drunken Dragon Festival was being held—May 25, 2015, which was the eighth day of the fourth moon in that year. Festival participants were approached in the festival venues, including Red Market, St. Dominic's Market, and Iao Hon Market, while they were waiting to collect the

longevity meal. Non-participant resident sample was collected two years later during the Drunken Dragon Festival period. Traditional intercepting method was used to approach the resident non-participants. Data were collected around the market areas, including Red Market, St. Dominic's Market, Lourenco Market, and Patane Market, which are and are not the core venues of the festival. Trained student surveyors collected data in different venues during the three-day period of May 3, 5, and 6 in 2017. Four students who collected data at Red Market and St. Dominic's Market between 10 AM and 3 PM were at the venue where the main festival celebrations, including the rituals, the Drunken Dragon Dance, and the longevity meal distribution, and they were asked to more carefully sort out the participants of the festival. The festival was not being held during the other time slots.

The two sets of bilingual questionnaires were designed for the participants and the non-participants. First, in 2015, the first set of questionnaire for resident participants were developed in English and then was translated into Chinese. The Chinese translation was reviewed by three others who were bilingual in order to ensure that the translation was easily understood and the meanings were consistent. Then, in 2017, another set of questionnaire was developed based on the one used for the Macao residents. Most of the questions from the two-page survey questionnaire were maintained in order to facilitate the comparison of their perceptions and attitudes, and four more questions were added to fit with the context of non-participant residents. For this adjustment of the original questionnaire, a native Chinese with good command of English was hired to review the old questionnaire, adjust the translation, and translate a few additional items. The first part of the questionnaire included a screening question to identify Macao residents, participants and non-participants of the festival, and the awareness of the festival. The second part of the question asked previous participation of the festival. Non-participants of the current year were asked about the last year they participated in the festival as well as number of previous participation. The third part mainly asked about the perceive impacts of the festival, culturally, economically, socially and environmentally, in addition to other perceptual variable about current status of the festival and how they positively or negatively perceive about the current status of the festival. The next section focused on the residents' attitudes towards the transformation of the festival. Questions were asked with 7-point Likert scale, with 1=strongly disagree and 7=strongly agree. The last section captured the demographic profile of the participants, including their gender, age, mother tongue, religion, occupational categories, and educational level.

Descriptive analyses of the items about non-participants' understanding about the current situation and transition of Drunken Dragon Festival were conducted. In order to compare the residents' perceptions and attitudes towards the festival by participation, a series of independent samples t-tests were used to compare the significance in mean values across the two samples at the significance level of .05.

RESULTS AND DISCUSSION

Sample Profile

For the festival participant sample, the research team had collected 378 responses during the Drunken Dragon Festival period in 2015. For the non-participant sample, in order to adjust to time difference, among the responses collected in 2017, those who participated in the Drunken Dragon Festival in 2015, 2016, or in 2017 were excluded. A total of 312 responses, collected and finished validity check, were used for the final comparison across the two samples. There was one missing value for four items and for occupation. Instead of replacing the missing value with other values, the missing values were excluded.

The demographic profile of the two samples is summarized in Table 1. The percentage of male and female respondents was roughly balanced. About two-thirds of the respondents from the participant group and slightly more than a half of the entire respondents from the non-participant group were female. There were more younger respondents (i.e., those below 35-years-old) in the nonparticipant sample than the participant sample. About 44% of the respondents in the participating group and about 53% from the non-participant group were below 35. The sampling may reflect that it may be the older generation who are behaviorally more involved with the participation and regularly attend the festival especially to collect the longevity meal. Reflecting such a difference in age groups, there were much more retired respondents from the participant group (n=87; 23.0%) than non-participants (n=14, 4.5%) and there were more student respondents from the non-participants (n=92, 29.5) than the participant group (n=83, 33.0%).

There were more white collar and professional workers from the non-participants (n=82, 26.3%) than the participants (n=67, 17.7%), and a similar pattern was found among the self-employed (participant group: n=13, 3.4%, non-participant group: n=34, 10.9%). On the other hand, there were more blue collar workers among the festival participants (n=68, 18.0%) than non-participants (n=50, 16.0%). Respondents from the non-participant group were more highly educated (primary: n=32, 10.3%, secondary: n=146, 46.8%, tertiary: n=134, 42.9%) than the participants (primary: n=97, 25.7%, secondary: n=190, 50.3%; tertiary: n=91, 24.1%).

Table 1
DEMOGRAPHIC PROFILE OF THE TWO SAMPLES

		Participant		Non-participant	
		n	%	n	%
Gender	Male	133	35.2	139	44.6
	Female	245	64.8	173	55.4
Age	15-24	97	25.7	92	29.5
	25-34	70	18.5	75	24.0
	35-44	60	15.9	57	18.3
	45-54	56	14.8	51	16.3
	55-64	54	14.3	29	9.3
	65 or above	41	10.8	8	2.6
Occupation	White collar, professional	67	17.7	82	26.3
	Blue collar, skilled worker	68	18.0	50	16.0
	Domestic worker	12	3.2	19	6.1
	Student	83	22.0	92	29.5
	Retired	87	23.0	14	4.5
	Self-employed	13	3.4	34	10.9
	Unemployed	16	4.2	12	3.8
	Others	32	8.5	8	2.6
Education	Primary or below	97	25.7	32	10.3
	Secondary	190	50.3	146	46.8
	Tertiary	91	24.1	134	42.9
Total		378	100.0	312	100.0

Difference in the Context of Drunken Dragon Festival Participation

In order to understand the level of awareness of the cultural significance of the Drunken Dragon Festival and the festival organizers, two questions were asked: Level of awareness of the reason for celebration and that of the festival organizer. For both items, participants had significantly higher awareness at the significance level of .05. Participants had better understanding of the festival, and higher awareness of the organizer. The results imply that a lack of awareness of the significance and the organizers may partly explain why some do not

participate. Furthermore, participants had significantly higher sense of price about the festival than non-participants with the p-value less than .001.

In addition, participants had significantly higher interest in Macao’s cultural heritage, and they also had higher behavioural involvement in the Macao’s festival in general with p-values less than .001. The results shows that the participation in Drunken Dragon Festival is affiliated with the participants’ general interest in its local traditional festival and their activeness in participation in the local cultural festival. It is expected that those who attend Drunken Dragon Festival are the ones who are interested in the local traditional culture and who attend other traditional local festivals as well as this particular festival.

With regards to the question asking if they need to sacrifice or sacrificed time to attend the festival, the participants agreed more strongly than the non-participants, suggesting that those who are willing to participate are willing to invest time and effort to attend the festival. Interestingly, overall, non-participants slightly disagreed with the statement that they need to sacrifice time to attend, indicating that it is not the matter of time or distance that cause non-participation. The t-test results are summarized in Table 2.

Table 2
LEVEL OF AWARENESS OF THE FESTIVAL, AFFECTIVE EMOTION, GENERAL INVOLVEMENT, AND DEDICATION TO THE FESTIVAL

	Participant		Non-participant		p
	Mean	SD	Mean	SD	
Level of awareness					
Do not know why the Drunken Dragon Festival is celebrated	3.87	2.083	4.18	1.818	.036
Know the main festival organizer	4.09	2.198	3.64	1.889	.004
Affective emotion					
I’m proud that the Drunken Dragon Festival is held in Macao	5.47	1.531	4.78	1.465	<.001
General involvement					
Interested in preserving Macao’s cultural heritage in general	5.30	1.611	4.50	1.384	<.001
Usually attend traditional festivals in Macao	4.58	1.771	3.79	1.597	<.001
Dedication					
Sacrificed (or need to sacrifice) time to participate in and celebrate the Drunken Dragon Festival	4.95	1.756	3.65	1.700	<.001

Difference in Perceived Cultural Impact of the Festival by Participation

Participants agreed more strongly with the statements about the positive cultural impact of the festival as well as its cultural roles with the p-values less than .001. Participants perceived more strongly than non-participants that the festival reflects the participants’ cultural identity as well as the region’s culture. Furthermore, the participants perceived more strongly about its positive cultural impacts in contributing to maintaining its local traditions (participants: m=6.03, SD=1.176; non-participants: m=5.55, SD=1.343) and in enriching its culture (participants: m=5.80, SD=1.198; non-participants: m=5.23, SD=1.310). The results may imply that those who attend the festival recognize its cultural features and identity strongly enough by having a first-hand experience of the festival—witnessing the rituals and participating in the activities at the festival venue, thus strengthening and being reminded of the cultural role of the festival. Furthermore, the results also can be interpreted reversely: Those who are strongly involved in the festival and those who recognize its cultural characteristics and impacts may be willing to spend time to attend the festival in person. The results are summarized in Table 3.

Table 3
PERCEIVED CULTURAL IMPACT OF THE DRUNKEN DRAGON FESTIVAL BY PARTICIPATION

	Participant		Non-participant		p
	Mean	SD	Mean	SD	
Reflects cultural identity	5.12	1.572	4.27	1.452	<.001
Reflects Macao's culture	5.71	1.330	5.28	1.287	<.001
Maintains local traditions	6.03	1.176	5.55	1.343	<.001
Enriches Macao's culture	5.80	1.198	5.23	1.310	<.001
Meets the needs of the society to celebrate its culture	5.61	1.223	5.02	1.227	<.001

Difference in Perceived Economic Impact of the Festival by Participation

There was a significant difference in the mean values of the perceived economic impact in different groups of festival participants and non-participants with the p-values less than .001 for all related items. Interestingly, non-participants rather than participants strongly perceived about the economic benefits. This might have happened because, at the festival venue, the participants experience that there are no visible commercial activities being conducted as a part of this festival—there is no entrance fee; performances and rituals are open to public; and longevity meal is distributed for free. This is also reflected from the statement asking if the respondents perceive commercialized features of the festival. It is partially reflected in the statement asking about perceived commercialization: The participants, overall, slightly disagreed with the statement that the festival is commercialized. First-hand experience of the festival may cause them to realize that it is questionable if the festival is commercialized and it has economic contributions. The results about perceived economic impacts of the festival are summarized in Table 4.

Table 4
PERCEIVED ECONOMIC IMPACT OF THE DRUNKEN DRAGON FESTIVAL BY PARTICIPATION

	Participant		Non-participant		p
	Mean	SD	Mean	SD	
Is commercialized	3.49	1.815	4.13	1.490	<.001
Brings economic benefits to Macao	4.10	1.749	4.59	1.395	<.001
Brings economic benefits to the place where it is celebrated	4.18	1.749	4.72	1.342	<.001

Difference in Perceived Social Impact of the Festival by Participation

Overall, the non-participants perceived more strongly than the participants about the exclusive nature of the festival, with one of the items being significantly different in mean values with the p-value being less than .001. Non-participants may feel that the festival is relatively an exclusive one for those who are familiar with and affiliated with it. The results may indicate the reason for non-participation might be because they feel this festival is a small community festival, not the region-wide and nation-wide one which tends to be open to different groups in the society. The results are summarized in Table 5.

Table 5
PERCEIVED SOCIAL IMPACT OF THE DRUNKEN DRAGON FESTIVAL BY PARTICIPATION

	Participant		Non-participant		p
	Mean	SD	Mean	SD	
Is not participated by the entire Macao society	4.64	1.652	4.86	1.406	.054
The general public does not participate in the the Drunken Dragon Festival	3.90	1.749	4.46	1.409	<.001
Does not bring different people together	3.98	1.809	3.96	1.650	.916

Difference in Perceived Environmental Impact of the Festival by Participation

Respondents from the participant group were less negative about the perceived environmental impact of the festival. The participants were significantly less negative about the statement that the festival caused litter with the p-value less than .001 (Table 6). The results show that the first-hand experience about the festival enables the participants to perceive that the festival is environmentally decently managed than those who have not participated in the festival recently. Considering that previous participants are also in the sample, the festival may be environmentally controlled better recently than previous years.

Table 6
PERCEIVED ENVIRONMENTAL IMPACT OF THE DRUNKEN DRAGON FESTIVAL BY PARTICIPATION

	Participant		Non-participant		p
	Mean	SD	Mean	SD	
I don't think the Drunken Dragon Festival causes litter	4.57	1.768	3.53	1.532	<.001

Attitudes towards Transformation of the Drunken Dragon Festival

Transformation of the festival in general and the change of cultural space and time for celebration in this case is one of the ways to increase awareness of the festival among the non-participant residents and tourists. The results show that both participants and non-participants were positive about sacrificing spatial authenticity for enhanced awareness and image of the festival. However, both groups were negative about changing the date to celebrate the festival, indicating that one of the elements that make this traditional cultural festival more authentic than others may be because of the time that the festival is held. Because of that notion, the participants may strongly support keeping temporal authenticity (Table 7).

Table 7
ATTITUDES TOWARDS TRANSFORMATION OF THE DRUNKEN DRAGON FESTIVAL BY PARTICIPATION

	Participant		Non-participant		p
	Mean	SD	Mean	SD	
No problem with the Drunken Dragon Festival being held at other locations.	4.93	1.788	4.56	1.607	.004
No problem if the Drunken Dragon Festival performances are held in UNESCO World heritage sites	5.00	1.739	4.80	1.546	.123
No problem if the Drunken Dragon Festival performances are held at tourist venues.	4.67	1.916	4.50	1.703	.218
Should be held on the eighth day of the fourth moon.	5.65	1.564	5.04	1.379	<.001

Attitudes towards Social Incorporation of the Drunken Dragon Festival

Overall, the participants were significantly more positive about incorporating diversified participants and supporters than the non-participants. The results may imply, while non-participants perceive that the festival is more isolated, they feel less strongly that the festival should transform that much to incorporate those who tend to be excluded.

Table 8
ATTITUDES TOWARDS SOCIAL INCORPORATION OF THE DRUNKEN DRAGON
FESTIVAL BY PARTICIPATION

	Participant		Non-participant		p
	Mean	SD	Mean	SD	
Should encourage participation of people living in Macao with different cultural backgrounds	5.61	1.458	5.23	1.339	<.001
More tourists to participate	5.28	1.733	4.93	1.472	.005
The Drunken Dragon Festival should get external support	5.58	1.482	4.90	1.374	<.001

CONCLUSION

The purpose of this study was to explore the differentiated perceptions and attitudes towards traditional cultural festivals by examining a case of Drunken Dragon Festival in Macao. Interestingly, while the participants have positive perceptions about its cultural value and societal and environmental impact, they did not perceive that Drunken Dragon Festival is for profit. However, when they were asked about their attitudes towards future transformation, they were open-minded about sacrificing elements of authenticity and encouraging transformation by suggesting the festival to be promoted more extensively and to incorporate diverse groups of people while maintaining the date of this traditional festival. One possible reason is because young respondents were prevalent among the samples for this study. Young generation might not have very strong sentiments regarding authenticity and maintaining coherently the traditions and rituals of the festival. Rather, these young people could potentially feel by varying how the festival was celebrated could bring in new colour and vibrant to an otherwise traditional, mundane cultural celebration. Another explanation is the general population of Macao is generally born outside of Macao; in fact, the 2011 census shows that just over 40% of Macao's population was born in Macao, thus their cultural attachment – and in turn their views with regards to ensuring authenticity and traditions of the Drunken Dragon Festival is weak.

The study has implications in that, in order to enhance the participation in the Drunken Dragon Festival among the non-participants, it is crucial to let residents know the cultural significance of the festival as well as its characteristics. Educational programs could be incorporated in school curriculum so children grow up knowing local heritage and history rather than following a curriculum based in Hong Kong or other places as many schools do in Macao.

With such significance, it should be noted that the most critical limitation of this study is that the two samples were collected with two years of gaps. Future studies with better sampling methods may provide rooms for better understanding of the differentiated perceptions and attitudes towards this festival. Future studies also can be done not only on other different types of cultural festivals in Macao and overseas to see similar patterns can be found in other cases.

ACKNOWLEDGEMENT

This work was supported by the Institute for Tourism Studies, Macao (120/EST/2015 and 075/EST/2017).

REFERENCES

- Andersson, T. D., & Getz, D. (2008). Stakeholder management strategies of festivals. *Journal of Convention & Event Tourism*, 9(3), 199-220
- Arcodia, C., & Whitford, M. (2006). Festival attendance and the development of social capital. *Journal of Convention & Event Tourism*, 8(2), 1-18. doi:10.1300/J452v08n02_01
- Chhabra, D., Sills, E., & Cabbage, F. W. (2003). The significance of festivals to rural economies: Estimating the economic impacts of Scottish Highland Games in North Carolina. *Journal of Travel Research*, 41(4), 421-427. doi:10.1177/0047287503041004012
- del Barrio, M. J., Devesa, M., & Herrero, L. C. (2012). Evaluating intangible cultural heritage: The case of cultural festivals. *City, Culture and Society*, 3(4), 235-244. doi:10.1016/j.ccs.2012.09.002
- Getz, D., & Page, S. J. (2016). Progress and prospects for event tourism research. *Tourism management*, 52, 593-631.
- Laing, J., & Frost, W. (2014). *Rituals and traditional events in the modern world*. London; New York: Routledge.
- Lee, I. S., Arcodia, C., & Lee, T. J. (2012). Key characteristics of multicultural festivals: A critical review of the literature. *Event Management*, 16(1), 93-101. doi:10.3727/152599512x13264729827758
- Lee, S., & Kim, A. (2014). Re-creation of traditional ritual into festival: The case of the Kangnung Danoje festival in South Korea. In *Rituals and Traditional Events in the Modern World* (pp. 67-77). New York: Routledge.
- Macao Government Cultural Affairs Bureau. (2017). 2017 Macao International Museum Day Carnival opens in May revealing the fusion between museums and local festivities. Retrieved from <https://www.icm.gov.mo/en/news/detail/14971>
- Macau Temple Civilization. (2017). Feast of the Drunken Dragon. Retrieved from <http://www.temple.mo/?mod=festival&id=55&lang=en>
- Mair, J., & Laing, J. H. (2013). Encouraging pro-environmental behaviour: The role of sustainability-focused events. *Journal of Sustainable Tourism*, 21(8), 1113-1128. doi:10.1080/09669582.2012.756494
- Mair, J., & Whitford, M. (2013). An exploration of events research: Event topics, themes and emerging trends. *International Journal of Event and Festival Management*, 4(1), 6-30. doi:10.1108/17582951311307485
- Reid, S., & Arcodia, C. (2002). Understanding the role of the stakeholder in event management *Journal of Sport & Tourism*, 7(3), 20-22
- Richards, G., de Brito, M., & Wilks, L. (2013). *Exploring the social impacts of events* Abingdon, UK Routledge.

Richards, G., & Palmer, R. (2010). *Eventful cities: Cultural management and urban revitalisation*. London Butterworth-Heinemann.

Ritchie, B. W., Shipway, R., & Cleeve, B. (2009). Resident perceptions of mega-sporting events: A non-host city perspective of the 2012 London Olympic Games. *Journal of Sport & Tourism*, 14(2-3), 143-167. doi:10.1080/14775080902965108

Small, K., Edwards, D., & Sheridan, L. (2005). A flexible framework for evaluating the socio-cultural impacts of a (small) festival. *International Journal of Event and Festival Management*, 1(1), 66-77.

Wilks, L. (2011). Bridging and bonding: Social capital at music festivals. *Journal of Policy Research in Tourism, Leisure and Events*, 3(3), 281-297. doi:10.1080/19407963.2011.576870

Wood, E. H. (2005). Measuring the economic and social impacts of local authority events. *International Journal of Public Sector Management*, 18(1), 37-53. doi:10.1108/09513550510576143

THREATS TO SAFEGUARDING TRADITIONAL CULTURAL FESTIVALS IN MACAO

UBALDINO SEQUEIRA COUTO

Institute for Tourism Studies, Macao

PHILIP KING LOK CHAN

Institute for Tourism Studies, Macao

ABSTRACT

Not only traditional cultural festivals bring positive social benefits to the society, they are extremely vital to Macao's economy, which is hugely dependent on gaming and tourism, with source markets mostly from mainland China. It is therefore important to ensure the continuity of the traditional cultural festivals in order to meet civic objectives and offer tourism appeal. Although event studies and heritage management are very different fields of study, they are interrelated as they both concern the relationship of cultural festivals and the community, as well as how tourism play a role in the continuity of cultural festivals. However, there is a lack of dialogue between these fields of study but they both call for the use of policies to ensure the traditional cultural festivals are safeguarded. Using Macao as the case, this paper discusses the different threats to safeguarding cultural festivals in Macao and possible mitigating actions, particularly through implementing public policies. It concludes by highlighting the deficiency of legislations alone and calls for 'softer' approaches to safeguarding traditional cultural festivals.

Keywords: safeguarding, ICH, traditional cultural festivals, Macao, authenticity

INTRODUCTION

Not only traditional cultural festivals bring positive social benefits to the society, they are extremely vital to Macao's economy, which is hugely dependent on gaming and tourism, with source markets mostly from mainland China. Following the 5th Twelve Years Plan of China, the Macao government positions itself as the 'World Centre of Tourism and Leisure', a strategic complement to Macao's 'One Centre, One Platform' direction bestowed upon Macao by the central government in Beijing to realise the city's function within the 'Belt & Road' initiatives by President Xi Jinping of the People's Republic of China. The variety and uniqueness of Macao's traditional cultural festivals not only function as economy powerhouse and place for social gathering and entertainment, they reaffirm Macao's historical and political position as the bridge between China and the West, through its attachment with Portuguese-speaking countries (Du Cros, 2009). Using Macao as the case, this paper discusses the different threats to safeguarding cultural festivals in Macao and possible mitigating actions, particularly through implementing public policies. It concludes by highlighting the deficiency of legislations alone and calls for 'softer' approaches to safeguarding traditional cultural festivals.

SAFEGUARDING CULTURAL FESTIVALS

Research related to safeguarding traditional cultural festivals in event studies dominate on one of the two major discourses: the role of tourism in festival authenticity and the issue of long-term sustainability of events (Getz & Page, 2016).

The ongoing debate between destroying or preserving authenticity of cultural festival is the result of the commodification of festivals for tourism (Getz, 1998). The argument – or dilemma – posits that that on the one hand, cultural festivals lose the authentic elements as they are managed to cater for tourists' needs while on the other, tourism actually helps to preserve the authenticity of cultural events. Recent empirical research suggests that the latter is also based on the premise that tourists seek for authentic experience which in turn increases festival loyalty; therefore, it is essential for festival organisers to deliver one (Girish & Chen, 2017). Indeed, authenticity issues discussed in the fields of tourism and hospitality are largely based on the relationship between authenticity, satisfaction, loyalty and return visitation. Wilson et al (2017) note five main themes in festival research: the motivations for organizing, funding and attending festivals; the experiences of festival attendees; the relationship between festivals and their local environments; the economic and sociocultural impacts of festivals; and the management of festivals. This is largely consistent with an earlier review by Getz (2010), which identifies the roles, meanings and impacts of festivals in communities; festival tourism and festival management as the three main discourses in festival research.

Research in festivals from a stakeholder perspective suggests that the identity of cultural festivals is different among stakeholders, with policy makers more focused on economic and political issues while festival producers on cultural significance (Crespi-Vallbona & Richards, 2007). This reinstates the danger of staging festivals to satisfy various needs of the stakeholders, such as to cater the needs of the tourists, rather than to meet the intrinsic cultural needs and civic obligations. Interestingly, a study recently concludes that heritage tourists value more intra-personal authenticity than object-related and inter-personal authenticity (Lin, 2017). Therefore, it is imperative that festivals are authentic and conform to a single, shared identity.

Cultural festivals are rooted in the identity of the community and place (Getz, 2007). The support of residents is therefore vital to ensure that festivals are celebrated not only for the community but with and by the community. Festival attendance creates positive social benefits (Arcodia & Whitford, 2006), for example, festivals enhance the sense of belonging of the community celebrating festivals (Van Winkle & Woosnam, 2014). A recent study (Li & Wan, 2017) reinstates this notion in that positive festival impacts are related to identity attachment and emotional solidarity in the community.

The support from the community ensures that festivals are sustainable in the long-term, not in the sense of environmentally sustainability, but in the sense that festivals have the continuity that they are celebrated again and again. From an event tourism perspective again, Getz & Page (2016) relate sustainability in this sense from an event portfolio approach (Ziakas, 2014), “some thought has to be given to the image and freshness of events appealing to specific market segments, and the attractiveness of the overall of events... the health of the portfolio is probably more important than the sustainability of appeal of individual events” (p. 613). In other words, the continuity of an authentic and cultural festival which becomes institutionalised within a destination's touristic offering may slowly lose its appeal to return tourists who seek novelty.

This observation is contradictory in nature. On the one hand, cultural festivals have to be authentic and rooted to its culture so as to meet civic and identity objectives while on the other hand, festivals have to be innovative that caters for tourists' changing and different tastes, as well as to ensure novelty to attract return visitors. Therefore, it festival organisers are faced with a dilemma of whether to innovate the festivals or to maintain its traditions and authenticity. Based on the premise that destinations should attract high quality cultural

tourists who create less negative impacts and bring positive benefits to the community, cultural festivals are best left untouched, and even if there are tourists involved, there should be minimal impacts to the festivals and the community in which they are celebrated (McKercher & du Cros, 2012).

The concept of conservation is well acknowledged in cultural heritage management, which refers conservation as an overarching concept that includes all the processes of looking after a place so as to retain its cultural significance. Cultural significance is referred to the aesthetic, historic, scientific, social or spiritual value for past, present or future generations. These values are embodied in the place itself, its fabric, setting, use, associations, meanings, records, related places and related objects (Australia International Council on Monuments and Sites, 1999). Typically, the concept is only applicable to tangible heritage including movable and immovable heritage such as artefacts and monuments. With the basic dichotomy of tangible heritage and intangible heritage under cultural heritage, the need of protecting or sustaining intangible heritage emerged, especially after the notion of safeguarding ICH was consolidated by the United Nations Educational, Scientific and Cultural Organization (UNESCO) in 2003. The rationale behind safeguarding is that intangible cultural heritage is important as a mainspring of cultural diversity and a guarantee of sustainable development.

The Convention for the Safeguarding of Intangible Cultural Heritage (UNESCO, 2003, p. 2) defines intangible cultural heritage (ICH) as “the practices, representations, expressions, knowledge, skills...that communities, groups and, in some cases, individuals recognize as part of their cultural heritage”. It further states that ICH falls into one of the five domains: oral traditions and expressions; performing arts; social practices, rituals and festive events; knowledge and practices concerning nature and the universe; and traditional craftsmanship. The need for an international agreement on safeguarding ICH were based on several factors: interdependence of tangible and intangible heritage, globalisation and social transformation, universal concern of humanity, and cultural diversity and human creativity. Traditional cultural festivals potentially encompass all five ICH domains in terms of why and how the festivals are organised, when and where the festivals take place, who are those involved, as well as the rituals and traditions that are carried out within the operation of the festivals. The use of charters and conventions to safeguard heritage has also been adopted in built structures and has been applied in an Asian context; for example, Taylor (2004) provides a useful commentary on the use of such policies in heritage management in Asia.

The legislation provides a framework of community participation including the nomination, consultation and promotion for ICH. This was highly regarded by UNESCO as ICH and people within communities are inseparable. Another point of merit goes to the periodic review of the ICH list; two rounds of reviews were undertaken over the past eleven years that recognised the addition of four and five items to list respectively. Furthermore, the mandate of the authority and the law ensures documentation and creation of a database for the respective ICH items. It is considered a contribution to the inheritance of traditional cultural festivals and other forms of ICH in future generations. The promotion of ICH is usually delivered through the activities organized by the transmitters' affiliated organisations and other NGOs. It is also worthwhile to note that the government typically has no obligation of offering any forms of incentives and support on this matter by law.

Threats to safeguarding traditional cultural festivals in tourism and event studies are related to authenticity and sustainability, but these threats are more than often unclearly defined with lack of studies that explicitly highlight such important issues. The Convention (p. 3) further defines safeguarding as “measures aimed at ensuring the viability of the intangible cultural

heritage, including the identification, documentation, research, preservation, protection, promotion, enhancement, transmission, particularly through formal and non- formal education, as well as the revitalization of the various aspects of such heritage“.

Although event studies and heritage management are very different fields of study, they are interrelated as they both concern the relationship of cultural festivals and the community, as well as how tourism play a role in the continuity of cultural festivals. There is a lack of dialogue between these fields of study but they both call for the use of policies to ensure the authenticity and sustainability of cultural festivals (Getz & Page, 2016; UNESCO, 2003). This converging point is best manifested in the Convention which outlines the steps needed for countries to undertake to safeguard intangible heritage and also possible means of safeguarding heritage, for example, through education (see Kurin, 2004 for a critical review of the Convention).

DATA COLLECTION

Using Macao as the case, this paper discusses the different threats to safeguarding cultural festivals in Macao and possible mitigating actions, particularly through implementing public policies. An auto-ethnographic approach is adopted to guide the discussion; specifically, field notes, reflections and photographic records are used extensively to elaborate and justify these threats to cultural festivals in Macao.

INTANGIBLE CULTURAL HERITAGE IN MACAO

In 2006, a year after the successful inscription of the Historic Centre of Macao onto the UNESCO World Heritage List, The Convention for the Safeguarding of Intangible Cultural Heritage has also become effective since then (Imprensa Oficial, 2006). The local efforts in safeguarding ICH lie with the mandate of government authority and legal measures. The Cultural Affairs Bureau of the Macao Government (Instituto Cultural, IC) is the specialised government authority for drafting and implementing cultural heritage related policies, promoting, protecting and managing the cultural heritage of all types encompassing tangible and intangible, movable and immovable properties. The related legislation in Macao – The Macao Cultural Heritage Protection Law (11/2013) – also became effective in 2013. It delineates the categorization, identification, criteria and procedures for establishing ICH inventory and list, and the safeguarding measures, and empowers certain government agencies in order to exert a greater effort in protecting the ICH of Macao (Imprensa Oficial, 2013). One of the initiatives of establishing the ICH inventory is to collect new entries through community engagement. An on-going territory-wide ICH survey has been conducted since 2015. It welcomes nominations from any public or private organizations, groups and individuals, of whom can submit nominations to IC online or by printed forms.

Figure 1 shows the fifteen items on the List of Intangible Cultural Heritage of Macao (Cultural Affairs Bureau, 2017). It is worth noting that eight of them receive double recognitions as they also appear on the National List of ICH of the People’s Republic of China. Among these eight items, Cantonese Opera has even been inscribed onto a higher threshold – the Representative List of UNESCO.

Figure 1.
THE INTANGIBLE CULTURAL HERITAGE OF MACAO

Name of items	Categories		
	Macao	China	UNESCO
	List of Intangible Cultural Heritage	National List of Representative Elements of Intangible Cultural Heritage	Representative List of the Intangible Cultural Heritage of Humanity
Yueju Opera (Cantonese Opera)	X	X	X
Herbal Tea Brewing	X	X	
Woodwork –Religious Figure Carving	X	X	
Cantonese Naamyam (Narrative Songs)	X	X	
Taoist Ritual Music	X	X	
Festival of the Drunken Dragon	X	X	
Belief and Customs of A-Ma	X	X	
Belief and Customs of Na Tcha	X	X	
Macanese Gastronomy	X		
Patuá Theatre	X		
Belief and Customs of Tou Tei	X		
Belief and Customs of Chu Tai Sin	X		
Craft of Bamboo Scaffolding	X		
Procession of the Passion of Our Lord, the God Jesus	X		
Procession of Our Lady of Fatima	X		

Among those on the list, there are seven items that contribute to the domain of social practices and rituals but only one is represented in the form of traditional cultural festivals – the Festival of Drunken Dragon. However, there is a number of local traditional cultural festivals that has not yet been reviewed nor recognised:

- Chung Yeung Festival (Double-Nine Festival)
- Dragon Boat Festival (Tun Ng Festival)
- Feast of Kuan Tai
- Feast of St. John the Baptist
- Kwun Yum Festival
- Lou Ban Festival (Si Fu Festival)
- Mid-Autumn Festival (Moon Festival)
- Wah Kwong Festival
- Yue Lan Festival (Feast of Hungry Ghosts)

Although the efforts in legal recognition are seemingly sufficient, the sustainability of ICH remains questionable. Due to tourism development, urban transformation and demographic changes of recent decades, the safeguarding of ICH is ever more challenging in Macao. For instance, while a certain traditional cultural festival is under-going commodification for

addressing the interests of tourists and event sponsors; another one is facing the loss of its authentic cultural spaces. Besides, the increasing migrant population also indirectly and gradually dilutes the cultural identity of Macao, which is unfavourable in sustaining ICH.

In nearby Hong Kong, which is also a special administrative region of China and a former European colony, efforts in safeguarding traditional cultural festivals are largely similar. A territory-wide ICH survey has also been conducted in Hong Kong by the joint efforts of Hong Kong Government's Intangible Cultural Heritage Office and local universities. They employ a similar mechanism of administering the local inventory and representative list, all tentative representative list items must be those selected from the inventory. Apart from that, their inventory is maintained in multimedia format and is accessible to the public (Intangible Cultural Heritage Office, 2017). Meanwhile, Macao's authority can take this practice into consideration as it indeed adds transparency and facilitates the communication of the importance of the ICH items to the community.

Although Macao has a legal framework that protects traditional cultural festivals, it is necessary to adopt a 'bottom-up approach' that is organic, that starts from the people within the community as opposed to a 'top-down approach', which the community has to abide by the law to safeguard cultural festivals (see Wan, 2013 for a comparison of governance in tourism planning between Macao and Hong Kong). In other words, traditional cultural festivals should be protected based on the intrinsic needs and significance of the community rather than for the sake of protection only because it is the law. Based on observations made over the years, the two main threats to safeguarding traditional cultural festivals are threats related to economic developments and also the threats related to demographic features.

THREATS RELATED TO ECONOMIC DEVELOPMENTS

The tourism industry, led by the gaming sector is the lifeline of Macao's economy; estimates suggests the revenues brought by the casinos account to over 70% of Macao's GDP. Indeed, the principal economic indicators from statistics in 2016 are impressive (DSEC, 2017b): the GDP per capita in real terms was USD69,372 putting Macao as the top few in the world and tourist arrivals were 30.9 million to Macao, with an area of just 31 km². Moreover, gaming revenues of over USD28.5 billion contributed to 76.4% of total tax received by the government coffers, putting Macao's unemployment rate to one of the lowest in the world at 1.9%.

Macao's over dependence on the gaming sector, which is in turn over relied on a few principal source markets, is a potential problem for Macao's economy (Sheng & Zhao, 2016). With a lack of alternatives in the economy, the government must turn to diversifying its touristic offering and one such way is to strategically use festivals and events to create a unique destination proposition. Although this appears to be favourable because traditional cultural festivals are now strategically important to Macao's economy, it is important that protection through legislations are not set up only for the sake of preservation and conservation of intangible heritage.

In Macao, traditional cultural festivals such as the Festival of the Drunken Dragon, which is on the Macao intangible cultural heritage inventory (Cultural Affairs Bureau, 2017), has attracted unprecedented attention by the media and tourism bureau. For instance, the Drunken Dragon 'dance' ritual has been scheduled to be performed at various touristic locations in Macao during peak tourism season, in which the tourist board claimed to promote Macao's intangible heritage. The ritual is normally celebrated only on the festival date and

performed for auspicious reasons. Such pseudo performances raise concerns of authenticity and it may also potentially be disrespectful to the fishmonger community which celebrates it.

Corporations may also harness the exposure in traditional cultural festivals. In the Festival of Drunk Dragon, performers typically consume Chinese rice wine to induce an intoxicated state so as to perform the dance ritual. In recent years, the performers have been consuming beer (of a certain brand) instead of rice wine. The performers first claimed that beer was less harmful than rice wine because of a lower alcohol content. However, it was later found that the beer brand was sponsoring the event.

These examples are not restricted to traditional festivals on the inventory. For example, in the Feast of Pak Tai which is celebrated in the Taipa Old Village, the festivities include the distribution of auspicious food, communal dining and Chinese opera performances. In recent years, an 'opening ceremony' became part of the programme; it was professionally produced while the main festival elements take place afterwards. The Taipa Old Village is very close to the vicinity of the Cotai Strip, which is where the mega casino resorts are concentrated. It was later observed that one of the resorts was a sponsor of the festival and in one of the speeches delivered during the opening ceremony, it was noted that the sponsorship was a CSR effort as a 'give back' to the community since the resort has been sharing and consuming resources belonging to the people in Taipa. However, interviews with festival participants did not show that the sponsorship was beneficial to them in any way; the festival was funded by donations from the community and the government.

The Catholic processions have been attracting a lot of attention in the region, particularly in China where public worship is restricted. Macao is the only other destination in Asia apart from the Philippines where Catholic processions are celebrated to such a scale. Moreover, the Procession of Our Lady of Fátima in 2017 attracted many participants from outside of Macao because of the centennial celebrations of the apparition in Portugal. Consequently, changes were made in various aspects of the processions to cater for more pilgrims, for example, the starting point of the procession was moved to the Cathedral, many seats were reserved for overseas pilgrims, including prime locations during the procession, leaving many local pilgrims disengaged with the main religious activities leading to the procession, and during the procession, significantly far away from the main procession. Like other processions that are celebrated in Macao, these events reinstate Macao's historical influences by the Portuguese, and most importantly, they are events for the Macao community not as tourist spectacles nor for those outside of the Macao community. In recent years, the processions are conducted in Portuguese, Chinese and English to cater for the language needs of the pilgrims.

These examples outline three types of threats associated with economic developments. Firstly, the fame and popularity brought forth by the Festival of the Drunken Dragon on the inventory prompted the tourism bureau to organise pseudo-events, which raise concerns on authenticity. Secondly, the exposure brought forth by cultural festivals such as the Feast of Pak Tai overshadows the true meanings and needs of celebration by the community; this raises ethical concerns and practically creates issues with authenticity and sustainability – who is the festival for? Thirdly, the way that the Catholic processions are being celebrated in recent years, seemingly catering more for the overseas pilgrims than the local community, is potentially problematic as it potentially intensifies host-guest relationships, creating a 'them versus us' situation. Although there are legislations that protect and ensure the celebration and continuity of these festivities, the way that they are organised and managed presents threats to truly safeguard these traditional cultural festivals. If these are not managed properly, there

could be problems that arise such as the lack of community support, hostile attitudes towards guests and authenticity issues, that in turn challenges the sustainability of these festivities.

THREATS RELATED TO DEMOGRAPHIC FEATURES

The population of Macao has doubled since the transfer of sovereignty from the Portuguese to the Chinese in 1999; in the last ten years alone, the population increased 25.6% to 644,900 in 2016 (DSEC, 2017b). This increase was mainly due to relaxed immigrant policies, in part to attract talents coming to Macao to meet the labour needs brought forth by the unprecedented economic boom. According to the By-Census in 2016 (DSEC, 2017a), the population pyramid of Macao is a diamond shape, which is characterised by a broad middle and narrow top and base. In fact, the age group of 25 to 34 represented 20.7% of the total population. Another noteworthy observation is the place of birth of both the local and total populations; in 2016, just over 40% of the people in Macao were born in Macao with the majority from mainland China, followed by the Philippines, Hong Kong, Vietnam, Myanmar and Indonesia. The majority of whom had lived in Macao for a short period, many less than 5 years.

The demographic features outlined above present a number of problems. First, the young population are less likely to adhere to traditions; the majority of Chinese traditional festivals are not rooted religiously and many view these practices as folklore and superstitious. The young population are open to western cultures and more educated. Hence, the festivals may suffer from transmitting difficulties from the older generations who celebrate these festivities to younger generations who are disengaged and uninterested. Second, the proportion of those not born in Macao fail to attach themselves with Macao creating issues with cultural and place identity. Finally, although the majority of immigrants are from the Asian region, and even mostly of whom were from mainland China, they all possess different cultural traits. When festivals are celebrated to meet cultural needs and civic objectives, the sustainability of the festivals with regards to community participation and support becomes uncertain.

The Feast of God Tou Tei at Horta da Mitra Market, included as part of Macao's inventory under the group 'Belief and Customs of Tou Tei', suffers from a transmitting concern by the organisers of the festival, who are among the older in the community. Although the festival attracts participants who used to live in the community but now living in other districts and abroad, the organisers noted concerns with a lack of young participants in the festival. In the Feast of the Drunken Dragon, the performers are fishmongers who perform the dance ritual for divine protection, also noted the same concern with few young people entering the trade. The future of the festivals may be produced only for the sake of adhering to the community (and touristic) calendar as opposed to arising organically from the needs of the community, thus creating issues with both authenticity and sustainability.

The last time Macao government collected demographic data on religion was 1991; current estimates of Catholics in Macao make up 5% of the local population. Although the two prolific Catholic processions (Passion of Our Lord and Our Lady of Fátima) are on the inventory list, these events cause major disruption to traffic and business in the central district of Macao. With the majority of the population not belonging to the Catholic faith in which the processions are celebrated, there could be potential problems with community support and even conflict within the community with regards to place identity and conflict of using public resources (Seales, 2008).

The political instability in Hong Kong and Macao on the protests for universal suffrage and independence from China, as well as negative perceptions to the central government in Beijing

towards a number of political issues have instilled a negative resentment towards the Chinese identity, particularly among the younger generations. Although the people of Macao, Hong Kong and China share the same ethnicity as Chinese, they are essentially different in terms of cultural traits, such as traditions and social practice (Chou, 2012). This resentment in Hong Kong and Macao seems to widen this difference, potentially causing identity issues, which could in turn challenge the sustainability of traditional Chinese festivals in Macao. For example, the annual remembrance of the Tiananmen crackdown incident on 4 June 1989 held in Hong Kong is no longer celebrated and respected like in the past as the identity of the younger generations are less Chinese; to them, this was an issue in the mainland (Mai & Lau, 2017).

EXAMPLE OF A SOFT APPROACH TO INTANGIBLE CULTURAL HERITAGE

These cases are not exhaustive but a selected range to illustrate the deficiency of the related legislations. The institutionalisation of ICH safeguards traditional cultural festivals by ensuring the documentation, continuous monitoring and future organisation of these events. However, these policies fail to ensure that traditional festivals are authentic, in the sense that they are held organically with a genuine need of the community to celebrate the festivals culturally in accordance to tradition and to reaffirm identity.

One of the recurring themes in managing social impacts of events is to educate the stakeholders involved in these cultural festivals (Robertson, Chambers, & Frew, 2007; Wan, 2013). Education is a 'soft approach' in which the population are well informed of meanings and significance of traditional cultural festivals to the community. In this sense, policymakers and festival organisers must instil an awareness that these festivities are vital in affirming the community's cultural and place identity. Also enlisted as an ICH in the Hong Kong inventory (Intangible Cultural Heritage Office, 2017), the Tai Hang Fire Dragon has a concrete identity attached to the Tai Hang community in Hong Kong.

Every year, over 300 volunteers are recruited to produce the 240-foot long fire dragon, which is made by a special kind of hay. On the nights when the Fire Dance is performed, these volunteers carry the dragon and perform the ritual accordingly. The organisers pride themselves with the enthusiastic involvement of the volunteers, mostly men who have resided in the neighbourhood since birth, but also newer residents who moved into the area, as well as those who would return to volunteer and participate in the festival having moved out of the community. Each year, the festival also involves local schools and the wider community by organising side events such as drawing competitions and photography contests respectively. The festival manages to instil a sense of belonging within the community, manifested as community pride, volunteerism and different – seemingly unrelated – entities coming together. In this way, the festival ensures the authenticity and sustainability of the festival organically, as the community celebrates and organises the festival based on the needs of the community that arise naturally (although it is outside of the scope of the present paper, see Leong, 2013 for a further discussion on identity and policy related to cultural development in Hong Kong).

CONCLUSION

Although there has been significantly more interest in social impacts of festivals, there appears to be a lack of research that explicitly explores the issue of safeguarding traditional cultural heritage. It has been observed that the two major discourses related to safeguarding festivals are in the lines of authenticity and sustainability. This issue has garnered more interest in

heritage management, particularly following the establishment of the Convention for the Safeguarding of Intangible Cultural Heritage by UNESCO. A brief overview of progress in event studies and heritage management concerns in safeguarding traditional festivals suggests that policies are necessary.

Socio-economic issues are the main threats to safeguarding cultural festivals in Macao. Unprecedented economic developments and demographic features were the main issues. This paper highlights the deficiency of the Convention when applied in the case and context of Macao festivals. It advances the current discourse in event studies and cultural heritage management about cultural festivals, particularly in destinations which are focused on exploiting the benefits but lack a long-term vision of sustainability.

Government entities such as the tourism bureau and cultural heritage office need to be aware of survival threats to cultural festivals in the long run while promoting and safeguarding cultural festivals for residents and tourists. This paper provides the starting point for further dialogue and immediate attention to the future of cultural festivals. Although this paper uses Macao as a case, the research and practical implications are reminiscent in other destinations similar to Macao's features, such as a small, post-colonial, tourism-dependent destination undergoing rapid economic development.

REFERENCES

Arcodia, C., & Whitford, M. (2006). Festival Attendance and the Development of Social Capital. *Journal of Convention & Event Tourism*, 8(2), 1-18. doi:10.1300/J452v08n02_01

Australia International Council on Monuments and Sites. (1999). The Burra Charter. Retrieved from http://australia.icomos.org/wp-content/uploads/BURRA_CHARTER.pdf.

Chou, K. P. (2012). Building national identity in Hong Kong and Macao. *East Asia Policy*, September(2), 73-80.

Crespi-Vallbona, M., & Richards, G. (2007). The meaning of cultural festivals. *International Journal of Cultural Policy*, 13(1), 103-122. doi:10.1080/10286630701201830

Cultural Affairs Bureau. (2017). Intangible cultural heritage. Retrieved from <http://www.culturalheritage.mo/en/detail/2264>

DSEC. (2017a). 2016 Population By-Census Detailed Results. Retrieved from Macao: <http://www.dsec.gov.mo/>

DSEC. (2017b). Yearbook of Statistics 2016. Retrieved from Macao: <http://www.dsec.gov.mo/>

Du Cros, H. L. (2009). Emerging Issues for Cultural Tourism in Macau. *Journal of Current Chinese Affairs*, 38(1), 73-99.

Getz, D. (1998). Event tourism and the authenticity dilemma. In W. F. Theobald (Ed.), *Global Tourism* (Second ed., pp. 408-427). Oxford: Butterworth-Heinemann.

Getz, D. (2007). *Event studies: theory, research and policy for planned events*. London: Elsevier Butterworth-Heinemann.

Getz, D. (2010). The nature and scope of festival research. *International Journal of Event Management Research*, 5(1), 1-47.

Getz, D., & Page, S. J. (2016). Progress in Tourism Management: Progress and prospects for event tourism research. *Tourism Management*, 52, 593-631. doi:10.1016/j.tourman.2015.03.007

Girish, V. G., & Chen, C.-F. (2017). Authenticity, experience, and loyalty in the festival context: Evidence from the San Fermin festival, Spain. *Current Issues in Tourism*, 20(15), 1551-1556. doi:10.1080/13683500.2017.1296821

Imprensa Oficial. (2006). Aviso do Chefe do Executivo n.º 32/2006. Macao: Macao Government Retrieved from <http://bo.io.gov.mo/bo/ii/2006/38/aviso32.asp>.

Imprensa Oficial. (2013). Lei de Salvaguarda do Património Cultural Lei n.º 11/2013. Macao: Macao Government Retrieved from <http://bo.io.gov.mo/bo/i/2013/36/lei11.asp> - 11.

Intangible Cultural Heritage Office. (2017). First Intangible Cultural Heritage Inventory of Hong Kong Retrieved from http://www.lcsd.gov.hk/CE/Museum/ICHO/documents/3862785/3863408/First_hkich_inventory_E.pdf

Kurin, R. (2004). Safeguarding Intangible Cultural Heritage in the 2003 UNESCO Convention: a critical appraisal. *Museum International*, 56(1-2), 66-77. doi:10.1111/j.1350-0775.2004.00459.x

Leong, S. (2013). Cultural Policy and the Development of Local Cultures in Hong Kong. In S. Leong & B. W. Leung (Eds.), *Creative Arts in Education and Culture: Perspectives from Greater China* (pp. 27-39). Dordrecht: Springer Netherlands.

Li, X., & Wan, Y. K. P. (2017). Residents' support for festivals: integration of emotional solidarity. *Journal of Sustainable Tourism*, 25(4), 517-535. doi:10.1080/09669582.2016.1224889

Lin, Y. C. (2017). The willingness of heritage tourists to pay for perceived authenticity in Pingxi, Taiwan. *Current Issues in Tourism*, 20(10), 1044-1069. doi:10.1080/13683500.2015.1123677

Mai, J., & Lau, S. (2017). Activists in Hong Kong and China struggle to keep memories of 1989 Tiananmen crackdown alive after nearly three decades of silence from Beijing. *South China Morning Post*. Retrieved from <http://www.scmp.com/news/hong-kong/politics/article/2096710/activists-hong-kong-and-china-struggle-keep-memories-1989>

McKercher, B., & du Cros, H. (2012). *Cultural tourism: the partnership between tourism and cultural heritage management*. Abingdon, UK: Routledge.

Robertson, M., Chambers, D., & Frew, E. (2007). Events and festivals: Current trends and issues. *Managing Leisure*, 12(2-3), 99-101. doi:10.1080/13606710701406485

Seales, C. E. (2008). Parades and Processions: Protestant and Catholic Ritual Performances in a Nuevo New South Town. *Numen*, 55(1), 44-67.

Sheng, L., & Zhao, W. (2016). Strategic Destination Management in the Face of Foreign Competition: The Case of Macao SAR. *Journal of Travel & Tourism Marketing*, 33(2), 263-278. doi:10.1080/10548408.2015.1051198

Taylor, K. (2004). Cultural heritage management: a possible role for charters and principles in Asia. *International Journal of Heritage Studies*, 10(5), 417-433. doi:10.1080/1352725042000299045

UNESCO. (2003). Convention for the Safeguarding of the Intangible Cultural Heritage. Retrieved from <http://unesdoc.unesco.org/images//0013/001325/132540e.pdf>

Van Winkle, C. M., & Woosnam, K. M. (2014). Sense of community and perceptions of festival social impacts. *International Journal of Event and Festival Management*, 5(1), 22-38.

Wan, Y. K. (2013). A comparison of the governance of tourism planning in the two Special Administrative Regions (SARs) of China – Hong Kong and Macao. *Tourism Management*, 36, 164-177. doi:http://dx.doi.org/10.1016/j.tourman.2012.12.005

Wilson, J., Arshed, N., Shaw, E., & Pret, T. (2017). Expanding the Domain of Festival Research: A Review and Research Agenda. *International Journal of Management Reviews*, 19(2), 195-213. doi:10.1111/ijmr.12093

Ziakas, V. (2014). Planning and Leveraging Event Portfolios: Towards a Holistic Theory. *Journal of Hospitality Marketing & Management*, 23(3), 327-356. doi:10.1080/19368623.2013.796868

HOSTING THE SUMMER OLYMPICS ASSOCIATED WITH WORSENING INCOME INEQUALITY—A PRELIMINARY ANALYSIS

LEONARDO DIOKO

Institute for Tourism Studies, Macao

RICH HARRILL

University of South Carolina, USA

ABSTRACT

Hosting mega- or hallmark-events is well known to exert significant socio-economic impacts on host communities. But most assessments are short term, narrow in scope, and ignore the broader ramifications. This study examines the effect of hosting of the summer Olympics on patterns of income inequality for 9 country-cities that have hosted the Games using a pre- and post-time series comparison of Gini coefficients. The findings suggest that, on average, up to a period spanning 5 years after hosting the summer Olympics, income inequality worsens by as much as 1.80 on the Gini coefficient scale compared to the 5 years prior to hosting.

Keywords: mega-events, hosting, Olympics, income inequality, disparity

INTRODUCTION

This study estimates the effect of the summer Olympics on long-term changes in income inequality of host countries. It forms part of a larger researcher agenda that seeks to provide a more comprehensive socio-cultural evaluation of mega-events beyond the rather narrow perspectives normally provided by general income modelling approaches and cost-benefit analyses (Baade & Matheson, 2016; Madden 2002; Zimbalist, 2015). Extant studies on mega-events, in particular, narrowly frame socio-economic outcomes and do not extend beyond the short-term horizon (with a few exceptions, see (Baumann, Engelhardt, & Matheson, 2010). Calls for long-term and socially broader ramifications of hosting mega-events such as the Olympics are therefore becoming more resonant (Rose & Spiegel, 2011). This paper thus seeks to add to the corpus of studies that, while flourishing, nevertheless still inadequately assess the long-term consequences of hosting mega-events. In particular, the study seeks to highlight a new critical avenue on the possible linkages between hosting the Olympics game and long-term income inequality.

Inequality

Income disparity and the uneven distribution of wealth is one of the most central and defining problems in economic policy of the modern world. The issue pervades public discourse and remains a highly divisive issue in social, economic, and political debates. But even before policies mitigating inequality can be shaped and implemented, the rapid rise and development of modern industries such as mass tourism is further complicating –and possibly aggravating (Ortiz, 2017)—the situation. Potentially complicit in this development, alongside tourism, are industries that foster intensive and massive inflows of visitation within a short time period. Counted among these is the hosting of mega-events such as the summer Olympics.

For any community, hosting the Olympics understandably attracts considerable debate and discussion. The massive spending it entails, how such spending is to be financed, the

infrastructure needing to be built, and the immense social and economic disruption that occur before, during, and after the mega-event can have long-lasting implications and have therefore been the focus of many research studies. But there is little, if any, strong evidence of a link between the hosting of mega-events and long-run effects on income inequality.

Mega-events spending and its effect on income/economy

Pillay and Bass (2008) contend that poverty alleviation is unlikely to be the outcome of hosting mega-events such as the World Cup based on their broad review of international literature on the topic. Hiller (2000) similarly argues that mega-events proponents view such events less for their sporting features and more as symbol for urban restructuring and economic betterment or 'boosterism.' Though not specifically targeting income inequality, Minnaert (2012) examined the non-infrastructure benefits of the Olympics flowing toward socially excluded groups in various host cities, and found that poverty-alleviating outcomes that help mitigate income disparity such as skill development, employability, and job opportunities were not forthcoming even if these factors are often used to justify hosting.

But even among studies that specifically examine the economic impact or legacy of mega-events, few clear evidence of the long-term significance on income disparity or social inequality have emerged. Studies tend to be dominated by economic assessments (Lee & Taylor, 2005) and estimates or measurement of direct multiplier effects of hosting mega-events (Kasimati, 2003). Issues of inequality and income disparity as a result of hosting the summer Olympics and other mega-events are largely absent from legacy literature (Preuss, 2007). A few studies do look at the long-term impacts of mega-events but largely focusing on issues tangential to income inequality (Kang & Perdue, 1994).

The substantial spending or 'boost' spurred by mega-events hosting or the boost in visitor arrivals that normally accompany mega-events do not necessarily nor directly affect income disparity. The multitude of factors affecting inequality are not only numerous but also myriad and intricately related in a web of complex interrelations spanning political, demographic, and external changes or policies. There are a host of proximate as well as distant factors influencing income distribution and the inclusion of a mega-event in a long-spanning temporal process further complicates any attempt at delineating the complex web of factor relations.

In a study of Latin American countries which, as a group, experienced a decline in income inequality from 1990 to 2010 (and none of which hosted a summer Olympics until Brazil did in 2016), Cornia (2013) identified a range of external and internal factors affecting a more equal distribution of disposable income. These factors can also range from proximate to distant in their effects and can span macroeconomic (such as taxation, trade, exchange rates, and economic activity) and demographic (e.g., dependency, education, and activity participation) factors. Among the most consequent factors alleviating income disparity and that may be spurred by the hosting of mega-events are job creation, favourable labour market conditions, income enhancement, and the redistributive effects of increased social spending such as in investments in infrastructure, housing, health, and education. Nevertheless, some research raise serious doubts about the enduring economic effects of hosting the summer Olympics. In their study, Baade and Matheson (2002) was so unconvinced that they categorically report "There is no economic residue that can be identified once the Games left town." Because some research even suggest that mega-events such as the Olympics tend to raise the cost of housing (Coates & Matheson, 2011), it may even be counter-posed that the Olympics can worsen income inequality since housing ownership is a relevant factor impacting economic disparity.

It is not within the purview nor the constraints of this paper to examine in detail the multiple factors involved and their complex, interrelated, and multi-level effects on income inequality and what the hosting of mega-events such as the summer games does to inhibit or catalyse the process. Instead this paper reports on a preliminary and possible cause for investigating such possibility in greater depth.

METHODOLOGY

Using the Gini coefficient as a proxy measure for income inequality, the study collected Gini coefficient data for nine countries that hosted the summer Olympics between 1976 and 2012, with the range of data analyzed spanning 5 years before the year of hosting ($T - 5$) to 5 years after the event ($T + 5$). Gini data was collated from various sources but principally from available online databases as well as secondary sources ("DataBank World Development Indicators," 2017; Milanovic 2014). Where data was sparse (a commonly acknowledged problem in economic statistics particularly plaguing Gini computations), the study supplemented with secondary data sources from each country-city's statistical database, where available. Nevertheless, a full comprehensive data of all Gini coefficient is elusive due to the lack of data, temporal mismatch, or incomparability of definition. In some instances, estimates of Gini coefficients (e.g., from the World Bank) rather than raw data were the only available source.

Data for the Moscow Olympics (1980), for example, is not available and if so would likely be incomparable due to the widespread boycott it suffered. The Los Angeles Olympiad (1984) was similarly boycotted but at a lesser scale than Moscow 1980 and pre- and post-Gini data is available. Brazil (2016), the most recent host of the summer Olympiad is excluded from the study because no post-event Gini data is available for comparison. Table 1 lists the countries and respective Gini coefficients comprising the dataset for the analysis.

Table 1
ANNUAL GINI COEFFICIENTS OF SUMMER OLYMPICS HOST COUNTRY-CITIES AT YEAR OF HOSTING ($T=0$), FROM ($T-5$) YEARS, AND UP TO ($T+5$) YEARS

Year of hosting (Y=0)	Australia (2000)	China (2008)	Greece (2004)	Spain (1992)	UK (2012)	US Atlanta (1996)	Korea, Rep. (1988)	US Los Angeles (1984)	Canada (1976)	Average
-5	39.7	41.0	40.3	37.0	34.2	42.8	37.7	40.4	37.3	39.1
-4	39.8	39.1	39.6	31.4	34.3	43.3	37.4	40.3	36.8	38.2
-3	38.8	38.5	42.1	36.9	33.2	45.4	38.0	40.6	36.8	39.2
-2	41.8	39.4	40.3	34.1	33.7	45.6	38.0	41.2	36.3	39.3
-1	40.3	37.0	41.0	38.4	32.3	45.0	37.8	41.4	36.4	39.1
0	39.6	36.6	39.1	37.4	33.3	45.5	38.4	41.5	37.4	38.9
1	42.1	42.2	38.5	40.3	32.4	45.9	41.3	41.9	36.2	40.6
2	40.3	38.8	39.4	40.6	32.6	45.6	40.2	42.5	36.7	40.0
3	41.0	41.7	37.0	39.7	31.6	45.8	40.1	42.6	35.5	39.9
4	39.1	46.2	36.6	39.8	N.A.	46.2	38.3	42.6	35.8	41.3
5	38.5	47.3	42.2	38.8	N.A.	46.6	38.0	43.1	35.1	42.1

N.B. Data for the former Soviet Union, which hosted the widely boycotted summer Olympics in 1980, is not available. Brazil (2016) is excluded from the analysis due to its recent hosting and absence of post-event Gini data. Data for Korea comes from Ahn (1997). China's 2013 data was sourced from Han, Zhao, and Zhang (2016). UK data was sourced from Figure 5 of the Office of National Statistics report ("Household disposable income and inequality in the UK: financial year ending 2016," 2017).

To test whether hosting the summer Olympics resulted in a different trajectory for the Gini coefficient of the host country, interrupted time series analyses consisting of several homogeneity tests applied to pre- and post-event years were conducted on the time series database. Specifically, Pettitt's test for detecting change-points in an observation series (Pettitt, 1979) was the principal measure for detecting the effect of summer Olympics hosting

on Gini coefficients, whereby the null hypothesis is that observations are homogeneous and the alternative hypothesis is that a change in the data at a certain date occurred.

FINDINGS

Analysis suggests that on average, countries that hosted the summer Olympics experienced a rise in Gini coefficient for a period of up to T+5 years after the mega-event compared to T-5 years before hosting, with the mean Gini value increasing from 38.97 before the hosting to a mean value of 40.77 after the hosting ($K=30$, $t=0$, $p<.0001$). See Figure 1. However, the post-hosting effect on income inequality differs considerably for each individual host countries. In the case of five country-cities which includes the United States, which hosted the Olympics twice (Atlanta, 1996, and Los Angeles, 1984), and China (2008), Spain (1992), and South Korea (1988) the Gini coefficients rose markedly after the event. In the case of Australia (2000) and Greece (2004), hosting the Olympics had no perceptible effect on income inequality. Two country-cities registered significant declines in Gini after hosting the Olympics: Canada (1976) and the UK (2012), with their respective Gini coefficients dropping from 36.8 before hosting to 35.9 after hosting, ($K=26$, $t=0$, $p=.0241$) and from 33.85 to 32.44, ($K=18$, $t=-2$, $p<.0285$). See details in Figure 2.

Figure 1
MEAN GINI COEFFICIENT – ALL 9 HOST COUNTRY-CITIES

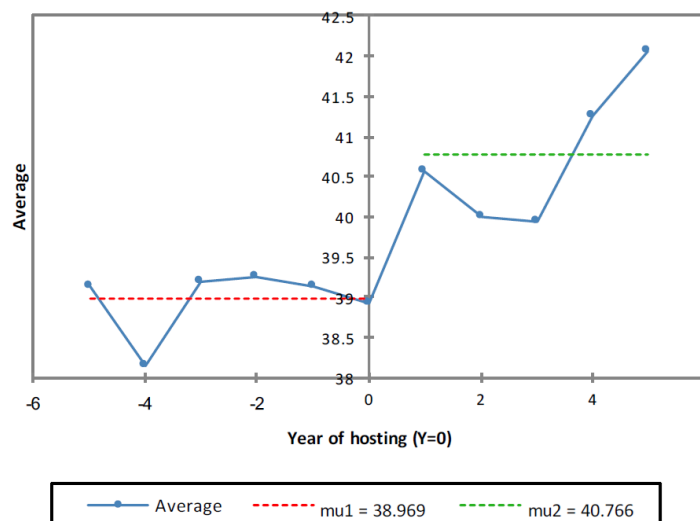

Out of the 9 Olympics hosting country-cities examined, 4 (China, US-Atlanta, Spain, and Canada) showed a significant change point (a rise) in the Gini data series temporally beginning a year after hosting, which suggests some degree of influence exerted by hosting on income inequality. Three country-cities, China (Beijing) and UK (London) experienced a significant change-point one year before the year of hosting. Counterbalancing the effect claim is that 3 host countries (the UK, Korea, and US-Los Angeles) showed detectable change in income inequality beginning one (T-1) to two (T-2) years before the year of hosting. Though this seems anomalous, such observations would not be completely unexpected given that massive public spending tends to escalate years before the Olympics is held (and hence it is plausible to see a change point before the year of hosting). Thus, because a change-point in Gini data patterns just before or a year after the hosting is detectable in 7 out of the 9 host country-cities examined, these observations suggest that hosting the Olympics has a significant association with a change in income inequality of the host community.

Figure 2
MEAN GINI COEFFICIENT

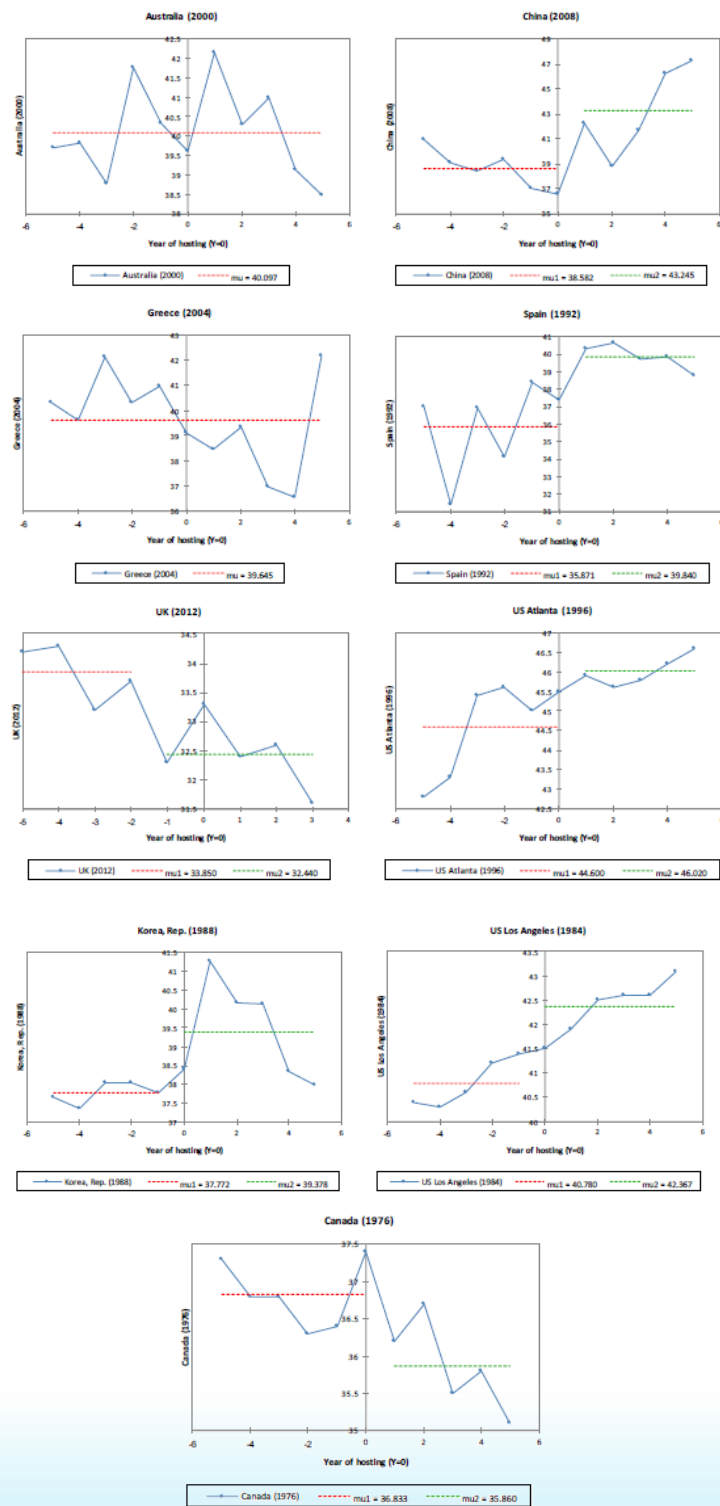

In terms of directionality, of the 7 hosting countries where a significant change point in Gini data corresponding or closely corresponding to hosting the Olympics was observed, 5 (US- Los Angeles, US-Atlanta, South Korea, Spain and China-Beijing) exhibited increases in Gini coefficient concomitant with hosting while 2 (the UK and Canada) showed decreases. Considering all individual cases, the evidence regarding the impact of hosting the summer Olympics on a host country's income inequality points toward a worsening effect, though it is

far from unqualified. On an aggregated basis and when the average Gini of all 9 countries is assessed, the data points toward an increase in income inequality up to a period of 5 years after hosting compared to 5 years prior.

DISCUSSION

The study's overall results, albeit tentative and considered only in aggregate, hints toward a general claim that hosting mega-events such as the Olympics can be general catalytic events associated with an increase in levels of income disparity. Since income disparity describes the distribution of income for populations, the study's results associates a worsening of income distribution with hosting the Olympics. While recognizing that correlation is not causation, these initial results are intriguing because of the occurrence of the change-point in Gini coefficient (on average and individually for 7 host country-cities) at or a year before a mega-event was hosted, which cannot be considered coincidental in accordance with Pettit's test.

There is even more curiosity in the pattern of results when individual countries' data is assessed, because the evidence is more disparate and less conclusive. Such mixed results suggests that other moderating or intervening variables need to be inputted into further analysis. These variables can include the type of government hosting (e.g., socialists versus market economy), the kind of organization created to manage the preparation of the Olympics (e.g., commercial oriented versus public-spending oriented), or the starting conditions of the economy (e.g., tax regimes and labour market conditions).

Even if a clear link between hosting the Olympics and income inequality were found (in either direction), it remains unclear how such hypothesized relationship is realized and whether the effect is consistent across differences in economic and other characteristics of Olympics host countries. Because hosting mega-events entails the deployment of massive amounts of funds, the results of this exploratory study suggest a greater need to investigate more concrete mechanism driving the posited relationship. For example, how funds are deployed matters just as much if not more than the amount spent for hosting, with the effects transcending direct and indirect economic repercussions, reaching into long-term social consequences for the host population for which the evidence reported remains tenuous (Kasimati & Dawson, 2009).

Because the current study reported is only at an initial and descriptive stage, there remains substantial work that needs doing to refine the analytic and design steps to ensure that external artificial factors do not confound posited link between hosting mega-events and income inequality. If future studies along these lines are successful, it would extend current knowledge of mega-events' impact far beyond the normal economic boosterism approach and uncover more long-term and socially broader ramifications of hosting mega-events such as the Olympics.

REFERENCES

- Ahn, K. (1997). Trends in and determinants of income distribution in Korea. *Journal of Economic Development*, 22(2), 27-56.
- Baade, R. A., & Matheson, V. (2002). Bidding for the Olympics: Fool's gold. *Transatlantic sport: The comparative economics of North American and European sports*, 127.

Baade, R. A., & Matheson, V. A. (2016). Going for the Gold: The Economics of the Olympics. 30(2), 201-218. doi:10.1257/jep.30.2.201

Baumann, R., Engelhardt, B., & Matheson, V. (2010). The Labor Market Effects of the Salt Lake City Winter Olympics. Retrieved from <https://ideas.repec.org/p/spe/wpaper/1002.html>

Coates, D., & Matheson, V. A. (2011). Mega-events and housing costs: raising the rent while raising the roof? *The Annals of Regional Science*, 46(1), 119-137. doi:10.1007/s00168-009-0340-5

Cornia, G. A. (2013). *Inequality trends and their determinants: Latin America over the period 1990–2010*: Oxford University Press.

DataBank World Development Indicators. (2017). Retrieved 17 May 2017, from World Bank Group <http://databank.worldbank.org/data/reports.aspx?ReportId=56146&Type=Table>

Han, J., Zhao, Q., & Zhang, M. (2016). China's income inequality in the global context. *Perspectives in Science*, 7(Supplement C), 24-29. doi:<https://doi.org/10.1016/j.pisc.2015.11.006>

Hiller, H. H. (2000). Mega-events, urban boosterism and growth strategies: an analysis of the objectives and legitimations of the Cape Town 2004 Olympic Bid. *International journal of urban and regional research*, 24(2), 449-458.

Household disposable income and inequality in the UK: financial year ending 2016. (2017). *Statistical bulletin*. Retrieved from Household disposable income and inequality in the UK website: <https://www.ons.gov.uk/peoplepopulationandcommunity/personalandhouseholdfinances/incomeandwealth/bulletins/householddisposableincomeandinequality/financialyearending2016>

Kang, Y.-S., & Perdue, R. (1994). Long-term impact of a mega-event on international tourism to the host country: a conceptual model and the case of the 1988 Seoul Olympics. *Journal of International Consumer Marketing*, 6(3-4), 205-225.

Kasimati, E. (2003). Economic aspects and the Summer Olympics: a review of related research. *The International Journal of Tourism Research*, 5(6), 433-444.

Kasimati, E., & Dawson, P. (2009). Assessing the impact of the 2004 Olympic Games on the Greek economy: A small macroeconometric model. *Economic Modelling*, 26(1), 139-146. doi:<https://doi.org/10.1016/j.econmod.2008.06.006>

Lee, C.-K., & Taylor, T. (2005). Critical reflections on the economic impact assessment of a mega-event: the case of 2002 FIFA World Cup. *Tourism Management*, 26(4), 595-603. doi:<https://doi.org/10.1016/j.tourman.2004.03.002>

Madden, J. R. (2002). The Economic Consequences of the Sydney Olympics: The CREA/Arthur Andersen Study. *Current Issues in Tourism*, 5(1), 7-21. doi:10.1080/13683500208667904

Milanovic, B. L. (2014). *All the Ginis, 1950-2012 (updated in Autumn 2014)*.

Minnaert, L. (2012). An Olympic legacy for all? The non-infrastructure outcomes of the Olympic Games for socially excluded groups (Atlanta 1996–Beijing 2008). *Tourism Management*, 33(2), 361-370. doi:<https://doi.org/10.1016/j.tourman.2011.04.005>

Ortiz, E. (2017, September 29). When Mass Tourism Drives Inequality. Retrieved October 21, 2017, from <https://inequality.org/research/mass-tourism-drives-inequality/>

Pettitt, A. (1979). A non-parametric approach to the change-point problem. *Applied statistics*, 126-135.

Pillay, U., & Bass, O. (2008). Mega-events as a Response to Poverty Reduction: The 2010 FIFA World Cup and its Urban Development Implications. *Urban Forum*, 19(3), 329. doi:[10.1007/s12132-008-9034-9](https://doi.org/10.1007/s12132-008-9034-9)

Preuss, H. (2007). The Conceptualisation and Measurement of Mega Sport Event Legacies. *Journal of Sport & Tourism*, 12(3-4), 207-228. doi:[10.1080/14775080701736957](https://doi.org/10.1080/14775080701736957)

Rose, A. K., & Spiegel, M. M. (2011). The olympic effect. *The Economic Journal*, 121(553), 652-677.

Zimbalist, A. (2015). The Illusory Economic Gains from Hosting the Olympics World Cup. *World Economics*, 16(1), 35-42.

TOWARD UNSUPERVISED MACHINE LEARNING TECHNIQUE TO DISCOVER THE KEY TOPICS INFLUENCE EXHIBITION VISITOR ENGAGEMENT IN SOCIAL MEDIA: A CASE STUDY FROM TAIWAN

CHUNG LING HUH

Fu Jen Catholic University, Taiwan

ABSTRACT

Unsupervised machine learning of text mining in social media has become a new research area in the past decade. Topic modelling is a probabilistic generative model that has been used in the field of computer science and bioinformatics. This pioneer study utilized topic modelling in unsupervised machine learning technic to analyze the contemporary exhibition visitor engagement in social media Facebook fan page. Latent Dirichlet Allocation (LDA) result supported that the visitors were highly concerned with gamification activities for an incentive prize both to create involvement and to enhance exhibition experience. The results visualization provide a professional exhibition organizer (PEO) with accurate information in developing successful E-WOM marketing strategies in social media or an exhibition management design for promoting successful exhibition visitor engagements in real time.

Keywords: Social Media, Exhibition, Text Mining, Topic Modelling, Latent Dirichlet Allocation LDA

INTRODUCTION

Social media platform (Facebook, Twitter, Instagram, YouTube or blog) became important communication and marketing tools in exhibition and event industry in the past decade. Social media platform allow a company to collect data and derive insight information from both message posted and customer's comments to predict customer behavior and resolve potential problems. Social media marketing has been dubbed the "word of mouth" marketing of internet age, the social media marketer is required to tap into an existing flow of information and seek positive communications between individuals and groups in virtual social networks. (Preston and Hoyle, 2012)

Social media has retained a large data of users and their personal interaction with friends and company, this data now provides new opportunities for research and implication. Social media data include the information of pasted texts, comments, the number of clicks on like, share and other information to be used as prediction variables. From 2006 to 2012, social media data as prediction-based studies has had rapid growth from 0% to 18%, social media data has also become popular in forecasting studies (Schon et al, 2013).

A limited amount of research has explored the subject of exhibition visitors' engagement preference perception through social networking media. Topic modelling originated from the field of natural language processing, LDA is a popular probabilistic topic model to discover a set of "topics" from a large collection of discrete data, it enhances researchers' ability to interpret information from text or document. Topic modelling is a kind of a probabilistic generative model that has been widely used in the field of computer science, bioinformatics (Liu et al., 2016) and social media in Twitter (Vosecky et al., 2014). This study apply topic modelling technique of Latent Dirichlet Allocation (LDA) to understand the exhibition visitor perception, for Professional Exhibition Organizer (PEO) as it carries out its exhibition design management and marketing planning. Text mining and topic modelling allow exhibition

organizers to use social networking platforms to extract emotion and attitude from visitors toward to the exhibition for commitment to exhibition engagements.

This study utilized both text mining and topic modeling technique to analyze the contemporary exhibition in social media Facebook fan page. The research objective include,

1. Using the text mining technic in Facebook fan page of two exhibitions to explore the key topic that influence the exhibition visitors' engagement.
2. Generate the valuable information through term frequency of word cloud analysis and topic modeling of LDA approach to provide results visualization.
3. Providing PEO with real time analysis technic for obtain accurate information to develop successful E-WOM marketing strategies in social media monitoring management.

LITERATURE REVIEW

A common metric of social engagement is the quantifiable volume of activity, a traditional form of social engagement, such as church going, may be measured by the number of one's visits to the church. In the Internet ages, is a metric of social engagement on a discussion board may take the form of the number of posts and comments made by visitors (Prohaska, Anderson & Binstock, 2012). Fredricks, Blumenfeld, and Paris (2004) have described three types of engagement: behavioral (participating), emotional (valuing), and cognitive (making a concerted effort).

Ahn (2013) used text mining exam customers' perception of brand images, research show the connection between users share their experiences and sentiments about an event and brands. The result of a data analysis, provides an understanding of the market in real-time customer management.

Littlewood and Bick (2014) proposed the social media value chain framework with three key areas. Customer engagement activities, online monitoring of communications by the social media community, and the utilization of metrics to measure the social media effectiveness to the drivers of success of social media campaigns. Research has confirmed the importance of setting strategies and objectives in order to measure returns by means of word of mouth, trust, loyalty and authentic business. Social media applications are broken down into three social media objectives, which include: brand awareness, brand engagement and word of mouth.

Guo and Chan-Olmsted (2015) proposed that perceptions, social media characteristics, and audience attributes to predict the social engagement experience, this investigation tested audience motives for using social media to engage with television content. Social engagement refers to the degree of interactions or connections, the core component of the construct "social engagement," was suggested that engagement is primarily driven by program content in the television consumption context, and the deepest engagement experience.

Visualization technology tools invented since 2008, and a growth in graphics has risen exponentially. Between 2011 and 2013, an average of 110 new infographics were created and published for the world to see every day (DeMers, 2013). Word cloud use the most frequently used words in text and randomly displays them by size. Word clouds also display words in different colors and shape in order to a pleasing look (deNoyelles & Reyes-Foster, 2015). Word cloud analysis is a visual representation of text data, they are usually single words, and the

importance of each words is shown with bigger size or bold color. This format is useful for quickly perceiving the most important terms associate with the text data.

Machine learning separate into two group, it depend on your data structure to choose supervised or unsupervised learning. Supervised learning, using the algorithm of decision tree, Support vector machine, neural network for classification and regression for prediction. In marketing analysis, they could do customer behaviour analysis, risk and fraud detection, identify potential customer, customer segmentation, customer loyalty analysis.

Unsupervised learning, using the algorithm of k-means, Hierarchical clustering, and Self Organize Map for clustering. Topic modeling of Latent Dirichlet Allocation (LDA) is a text mining technic in unsupervised machine learning, it simply clustering the word together through their correlation, which it is totally different from Linear Discriminant Analysis in supervised machine learning (Figure 1).

Figure 1
SUPERVISED LEARNING & UNSUPERVISED LEARNING

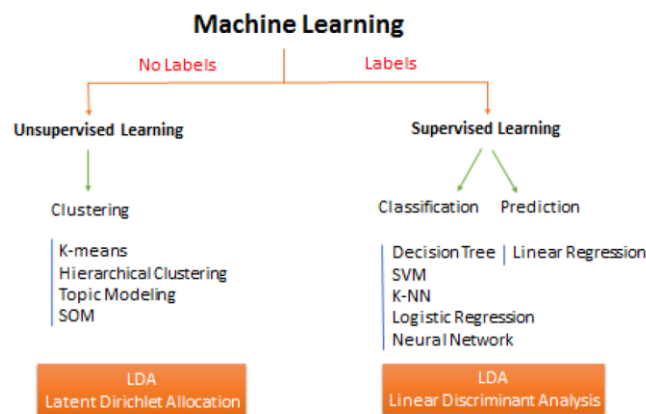

Text mining is a research area that tries to solve the big volume of information problem by using techniques from data mining, such as machine learning, natural language processing (NLP), information retrieval (IR), and knowledge management.

Text mining involves the preprocessing of document collections (such as, text extraction, term extraction), the unsupervised machine learning techniques to analyze these intermediate representations (such as sentimental analysis, clustering, correlation analysis, and association rules), and visualization of the results. Latent Dirichlet Allocation (LDA, show as Figure 2) of Topic modelling assumes that a text document has some probability distribution over “topics,” and each such topic is associated with a distribution over words. It assumes a generative probabilistic model in which documents are represented as random mixtures over latent topics, each topic is characterized by a distribution over words. Topic models are unsupervised models, they can be thought of as automatically clustering words into topics and associating documents with those topics.

Figure 2
GRAPHIC MODEL OF LDA WITH DIRICHLET- DISTRIBUTED TOPIC-WORD DISTRIBUTIONS (Blei et al., 2003)

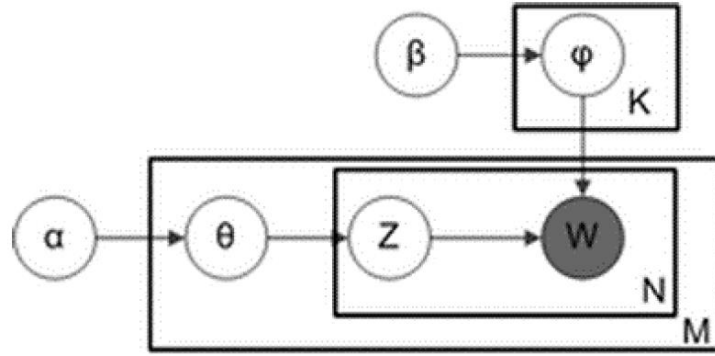

The outer box represents documents, while the inner box represents the repeated choice of topics and words within a document. M denotes the number of documents, N the number of words in a document. Thus:

α is the parameter of the Dirichlet prior on the per-document topic distributions, β is the parameter of the Dirichlet prior on the per-topic word distribution, θ_m is the topic distribution for document m , φ_k is the word distribution for topic k , Z_{mn} is the topic for the n -th word in document m , and W_{mn} is the specific word.

The notation for this model where K denotes the number of topics and $\varphi_1, \dots, \varphi_k$ are V -dimensional vectors storing the parameters of the Dirichlet-distributed topic-word distributions (V is the number of words in the vocabulary). The marginal probabilities of single documents obtain the probability of a corpus: (Blei et al., 2003)

$$p(D|\alpha, \beta) = \prod_{d=1}^M \int p(\theta_d | \alpha) \left(\prod_{n=1}^{N_d} \sum_{z_{dn}} p(z_{dn} | \theta_d) p(w_{dn} | z_{dn}, \beta) \right) d\theta_d.$$

RESERCH METHOD

This study used RDataMining software to analyze the data. It starts with extracting text from Facebook fan page of three years data from two famous exhibition in Taiwan. The extracted text is then transformed to build a document-term matrix. After that, select frequent words bigger than 30 and associations are found from the matrix. A word cloud is used to present important words in documents. In the end, a novel text mining method with unsupervised learning in nature language called topic modelling was applied to the exhibition visitor engagement labeling, with a goal of discovering “topics”. The topic modelling approach was used to extract different topic sets and their representative keywords emerging from a document corpus.

Performing R data mining procedure contain, first stage, retrieving exhibition visitor comment text from Facebook fan page through Application Programming Interface (API). Second stage, converting text to a corpus, and then transforming the corpus by changing letters to lower case, removing punctuations, numbers and stop words. Third stage, stemming Words to retrieve their radicals, so that various forms derived from a stem would be taken as the same when counting word frequency. Fourth stage, building a Term-Document Matrix to represents the relationship between terms and documents. Fifth stage, from the term document matrix, frequency of terms can be derived, and can find what are highly associated with the word are ordered by their correlation. Sixth stage, word Cloud can show the importance of words for visualization the result. Seventh stage, applied the topic modelling

approach to extract the different topic sets and their representative keywords across the data. Result interpret the value from factor matrices as the relevance score of a word or a document to a particular topic.

The research objective selected two famous exhibitions of Taiwan for following reason. According to The Global Association of the Exhibition Industry (UFI) report on The Trade Fair Industry in Asia, there are five UFI-sanctioned exhibition halls in Taiwan. At these halls 89 exhibitions were recorded, and Taiwan ranked 6th in Asia for total exhibition space sold (716,250 square meters). Advanced IT and communication technologies, plus mature industrial clusters will continue to strengthen Taiwan's global competitiveness. (meettaiwan, 2016)

In our study, Taiwan exhibitions have been chosen for their globally renowned for its highly-developed 3C industry, the integration of social media and technologies such as APPs, QR-Codes, Facebook, RFID, and free-of-charge Wi-Fi, all of which have been applied to exhibition activities, offering advanced, convenient, and real-time services to exhibition visitors. Taiwan has a number of international standard exhibition venues which include the TWTC Halls (1, 2, 3) and Taipei Nankang Exhibition Hall. The southern Kaohsiung Exhibition Center has officially opened to provide more exhibition space. In addition, more MICE venues, the Taichung Convention and Exhibition Center, and the Taoyuan Aerotropolis International Convention and Exhibition Center, have helped to lead Taiwan's MICE industry into a new area.

The Taiwan External Trade Development Council (TAITRA) founded in 1970, is the foremost non-profit trade promotion organization in Taiwan. It is jointly sponsored by the government, industry associations, and several commercial organizations. Each year, TAITRA holds more than 30 international trade shows. Those B to B events have attracted 10,000 exhibitors, both domestic and foreign, and a total attendance of 80,000 foreign buyers. Those shows have both assisted Taiwan businesses to enhance their global trading ties and have promoted the development of the exhibition industry.

Important trade shows held by TAITRA included 2016, COMPUTEX TAIPEI, the Taipei Int'l Cycle Show, the Taipei Int'l Machine Tool Show, the Taipei Int'l Food Show, the Taipei Auto Parts & Accessories Show, the Taichung Int'l Tea, Coffee and Bakery Show, the Taiwan International Fastener Show, the Taiwan International Boat Show, and the Kaohsiung Food Show. In this research, 2 exhibitions of COMPUTEX and the Kaohsiung Food Show were selected as our research objective, for their Facebook fan page consisted of three years of data which meet our research criteria.

Facebook is the favorite social media of people in Taiwan. More than 15 million participate monthly, of which 13 million participate by means of mobile devices. The ages range between 25 years to 34 years make up the main proportion of these participants. (FB, Reports First Quarter 2015 Results, April, 22, 2015).

RESULT ANALYSIS

Exhibitions profile

COMPUTEX TAIPEI is based upon Taiwan's outstanding ICT edge that offers a complete supply chain and includes the world's #1 supplier of notebooks, tablet PCs, motherboards, servers, wafer OEMs, LCD monitors, WLAN and PND. Since 1981, COMPUTEX TAIPEI has progressed as the ICT world has grown and transformed. Every year, top ICT elites, innovators

and entrepreneurs from every corner of the world gather to showcase the most advanced and innovative ICT products.

COMPUTEX is co-organized by the government-funded Taiwan External Trade Development Council (TAITRA) and private sector Taipei Computer Association (TCA). Venue sites are at the Taipei World Trade Center Hall 1, 2, 3, and the Nangang Exhibition Hall. COMPUTEX has since rapidly expanded and become an important global showcase for the IT industry. Now it has become the second largest computer expo in the world (after CeBIT) and the largest in Asia, with participation from major manufacturers such as Intel, AMD, NVIDIA, and others, as well as Taiwanese brand names such as Acer and ASUS. In 2015, it attracted over 130,513 visitors including 38,000 buyers. A total of 1,702 exhibitors occupied 5,072 booths.

The Kaohsiung Int'l Food Show is co-organized by the Taiwan Bureau of Foreign Trade and the Taiwan External Trade Development Council (TAITRA). The exhibition venue site is at the Kaohsiung Exhibition Center, in the southern part of Taiwan. The exhibition profile includes Fresh Fruits and Agricultural Products, Meat and Dairy Products, Fish Products, Health Foods/Leisure Foods, Food and Beverage Chains...etc. In 2015, it attracted 27,269 visitors, 250 exhibitors and 500 occupied booths.

Social media- Facebook fan page profile

Table 1 shows three years of two exhibitions of Facebook fan page like counts, comment counts, and share counts. Computex FB pages began in 2012. In 2013 the number of visitor click counts dropped tremendously. The FB like counts ranged from 20,269 counts in 2013 to 816 in 2015. The comment counts ranged from 363 counts in 2013 to 16 counts in 2015. This result showed that within a period of 3 years, the FB fan page population decreased their interaction tremendously. Kaohsiung Food Show also increased their interaction population from 3,397 counts in 2013 to 6,742 counts in 2015. This result shows that Kaohsiung Food Show consisted of better FB management to compare with Computex.



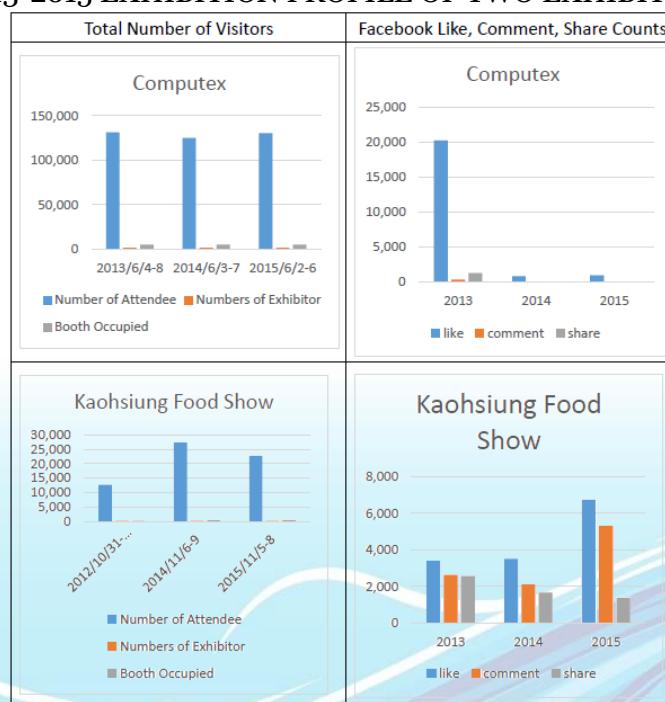
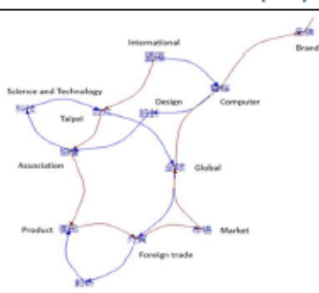

Table 1
2013-2015 EXHIBITION PROFILE OF TWO EXHIBITIONS



Word cloud and Linear Discriminant analysis

The result in Table 2 consists of three years Word cloud, LDA and Topic Modelling analysis, term frequency analysis in R software were employed. Text mining technology was adapted to identify important key words in the comment texts. Both word cloud analysis and Linear Discriminant analysis (LDA) are the most effective methods to use to visualize the results of text analysis.

Table 2
RESULT VISUALIZATION OF WORD CLOUD, LDA AND TOPIC MODELLING

Computex Taipei		Kaohsiung Food Show	
Word Cloud Analysis		Word Cloud Analysis	
			
Latent Dirichlet Allocation (LDA)		Latent Dirichlet Allocation (LDA)	
			
Topic Modelling		Topic Modelling	
Topic 1	Topic 2	Topic 1	Topic 2
International Taipei Association Product Foreign Trade Market Global Computer Brand	International Computer Design Association Science and Technology Taipei Global Foreign Trade Innovation	International Kaohsiung Food Activity Like & Share Fans Friend Obtain Free Win Big Prize	Food International Kaohsiung Fans Activity Like & Share Wine Big Prize Kaohsiung Cuisine Winner

This study result found, the word cloud result found that the COMPUTEX visitors are highly concerned with, First, the location of exhibition venue. Second, the main theme of exhibition which is related to innovation, technologies, branding and design. Third, global exhibitor and buyer, educational seminar, information exchange. Fourth, exhibition activities and related service. Fifth, product, computers, and peripheral items.

Result from LDA, Topic modellings' correlation of frequent term words demonstrated that the COMPUTEX Facebook visitors expressed their engagement preference from two topic. Topic 1 visitor concerned with the international COMPUTEX exhibition venue at Taipei Taiwan, the exhibited computer products should with brand name and the global market. Topic 2 visitor valued with computer products' design with science and technologies and innovation for global trade market.

The word cloud result found Kaohsiung Food Show visitors confirmed that highly concerned with, First, the food Show held in the venue located at Kaohsiung. Second, visitors are interested to participating in cooking contest activities. Third, an opportunity to win a free prize and a free ticket.

Result from the correlation of frequent term words at LDA and Topic modelling, also reflects the same perception with word cloud analysis. Topic 1 visitors concerned with winning big prize and obtain free gift in gamification activities. Topic 2 demonstrate that the visitors are interested in the exhibition held Kaohsiung cuisine contest with opportunity to win big prize, and the international Kaohsiung Food Shows' Facebook fan page with interactive activities with fans.

CONCLUSIONS AND LIMITATIONS

Studies result showed that a topic modelling can accomplish the task of clustering and classification of data. Furthermore, each topic is interpreted the important words of exhibition visitor engagement perception. The results visualization provide a professional exhibition organizer (PEO) with accurate information in developing successful E-WOM marketing strategies in social media or an exhibition management design for promoting successful exhibition visitor engagements, especially with regard to the area of Asian exhibition research.

This exhibition visitor research shows a usefulness in extracting and analyzing social media measures for exhibition visitor engagement. This research method could generalizable to other domains in many other industries. This analytics method may provide a professional exhibition organizer with accurate information in an exhibition management design for promoting successful exhibition visitor engagements. Study result demonstrates these exhibitions visitor engagements preferences from topic extracted. The PEO should able to make quality decisions both quickly and accurately in order to respond to exhibition visitor needs from social media platforms, and continuously monitor these platforms as their social media investment bursts into ROI.,

Social media has taken off in the modern exhibition trend, a lot of e-marketing through Twitter, Facebook, Instagram and exhibitors fan pages has taken place to increase visitor engagement. This study supported that use of gamification event and an incentive prize in social media would create visitor involvement and enhanced exhibition experience (Ramsborg, 2015). This study also showed that the location of exhibition venue are highly concern by the exhibition visitors. Research suggest that PEO should consider to creating a facebook event, and setting up an event group on Linkdelin and Instagram...ect, post session preview videos can be uploaded on youtube, blogs can began about featured demo or discussion topics. An exhibition app design should include a comment post area that can interact with visitors, so they can maximize their exhibition experience.

A mobile phone game activities has become very important, especially for the younger visitors. This research suggest that future exhibitions should have APP with all of exhibitor information and programs on it. Games activities in mobile phone APPs can increase visitor involvement and enhance a positive exhibition experience. A gaming pavilion and an area where that has readings and information about other events promote can help awareness. Over 3/4 of the present global population uses mobile phones, and over 25% use location-based services to communicate with event visitors (Ramsborg, 2015). The PEO should try to use topic modelling technique to promote exhibition in social media to boost buzz and participation.

This study validated the exhibition visitor engagement by providing evidence that social media measures the relationship between exhibition visitor engagement perception and Facebook fan page text messages, in order to a provide PEO and PCO guidelines for an exhibition management and marketing strategy.

Limitation of this research include, first, most of the text mining techniques are based on the word count strategies and cannot provide a reliable and valid result when the text is short. Second, when labeling language of these information containing ambiguous semantic descriptions, which poses a great challenge in retrieving useful information from the labeling text for comparative accurate topic analysis. Third, this study focused on social media Facebook. Further research could be extended to examine the validity and utility of different text-based social media like Tweeter, Blog...etc.

REFERENCES

Ahn, H.J. (2013). Mining Texts to Understand Customers' Image of Brands. *International Journal of Electronic Commerce Studies*, Vol.4, No.1, 131-134

Blei, D.M., Ng, A.Y. & Jordan, M.I. (2003). Latent Dirichlet Allocation. *Journal of Machine Learning Research*, Vol. 3, 993-10

DeMers, M., Patterson, A.K., Richman, R., Ahearn, S., Plewe, B. & Skupin, A. (2013). Toward an Immersive 3 D Virtual BoK Exploratorium: A Proof of Concept. *Transactions in GIS*, Vol. 17, No. 3, 335-352

DeNoyelles, A. & Foster, B.R. (2015). Using Word Clouds in Online Discussions to Support Critical Thinking and Engagement. *Online Learning*, Vol. 19, Issue 4, September 2015

Fredricks, J.A., Blumenfeld, P.C., & Paris, A.H. (2004). School engagement: Potential of the content, state of the evidence. *Review of Educational Research*, Vol. 74, Issue 1, 59-109

Guo, M. & and Olmsted, S.M.C. (2015). Predictors of Social Television Viewing: How Perceived Program, Media, and Audience Characteristics Affect Social Engagement with Television Programming. *Journal of Broadcasting & Electronic Media*, June, 240-258

Littlewood, K. & Geoff Bick, G. (2014). Developing the Social Media Value Chain: A Conceptual Framework for the Measurement of Social Media. Copyright of Proceedings of the European Conference on e-Learning is the property of Academic Conferences & Publishing International Ltd.

Liu, L., Tang, L., Dong, W., Yao, S. & Zhou, W. (2016). An overview of topic modeling and its current applications in bioinformatics. SpringerPlus, 5:1608, DOI 10.1186/s40064-016-3252-8

Meettaiwan (2016). Reports of Taiwan MICE Industry. Retrieved on January 5th, 2016, from http://www.meettaiwan.com/zh_TW/index.html

Facebook Reports (2015). First Quarter 2015 Results, April, 22nd, 2015. Retrieved on January 5th, 2016, from <http://www.prnewswire.com/news-releases/facebook-reports- first-quarter-2015-results-300070539.html>

Preston, C. & Hoyle, H. L. (2012). Event Marketing: How to Successfully Promote Events, Festivals, Conventions and Expositions (Second Edition). Hoboken, New Jersey, America.

Prohaska, T.R., Anderson, L.A. & Binstock, R.H. (2012). Public health for an aging society, JHU Press, 249–252

Ramsborg, G.C. (2015). “A Guide to Meetings, Conventions, and Events, Professional Convention Management Association”. U.S.A. Professional Meeting Management Sixth Edition

Schoen, H., Gayo-Avello, D., Metaxas, P.T., Mustafaraj, M., & Strohmaier, M. (2013). The power of prediction with social media. Internet Research, Vol.23, Issue 5, 528-543

Vosecky, J., Jian, D., Leung, K.W.T., Xing, K., & Ng, W. (2014). Integrating Social and Auxiliary Semantics for Multifaceted Topic Modeling in Twitter. ACM Transactions on Internet Technology, Vol. 14, No. 4, Article 27

RESEARCH ON THE DESTINATION TOURIST TRUST AND ITS INFLUENCE ON TOURISM IMAGE

LIU JUAN

Anhui Normal University, China

WANG ZHAO-HUI

Anhui Normal University, China

FANG SHI-MIN

Xingtan University, China

LI SHUANG-RONG

Anhui Normal University, China

ABSTRACT

The crisis of trust in tourist destinations has attracted wide attention since the tourism industry is in full swing, but the research on the influence of trust in tourist destinations has only just begun. This study, on the one hand, uses the grounded theory analyzing destination tourism trust constitute factors, the destination tourism trust evaluation index system composed of 5 indicators and 16 target layers is constructed, such as regional image etc. On the other hand, uses the structural equation model validate the impact path of the element of tourist trust to tourist trust, as well as its influential effect on the tourism image. Results show that: The composition factors of tourist trust are regional image, perceived quality, perceived value, emotional experience and behavioral tendency, and have significant influence on tourist trust. There are some dimensions of the tourist trust have significant influence on tourism destination image, others are not. The research conclusion has important guiding significance to the construction of destination trust and image construction.

Keywords: Tourist destination; tourist trust; tourism image; grounded theory; SEM

INTRODUCTION

Tourism is an important and strategic pillar industry sustained high speed and steady growth in the world economy. With the further development of economic globalization and world economic integration, tourism has entered the golden age of rapid development. When tourism is in full swing, however, the frequent outbreak of lapses of tourist destination as well as the contradiction among the tour guides, operators, local residents and tourists exploded in the middle of the crowd instantly under the effect of Internet dissemination and diffusion, triggered trust crisis in the tourism industry. Travelers lose faith in tourist destinations, and the good tourist image that has been built up over the long term is severely damaged.

Trust in tourist destinations is a prerequisite for tourists to go to the destination and a key quality to manage the market of tourist destination successfully (Abubakar, 2016; Choi, Law & Heo, 2016;). It is very important for tourism planning and development (Law, 2016). Studies have confirmed that tourist destination trust will influence tourists' attitude (Kim, Kim & Kim, 2009), satisfaction (Chang, 2014), loyalty (Mechinda, Serirat & Anuwichanont, 2010), revisit willingness (Su, Hsu & Marshall, 2014), risk perception (Kim, Kim & Shin, 2009) and destination attachment (Chen & Phou, 2013). It is crucial for building trust system and

establishing trust image to how to judge the tourists' trust in the destination. But, it is yet to be perfect at present about the evaluation index system of destination tourist trust. This study uses the grounded theory method to construct the model of destination tourist trust, and develops a scale to evaluate the tourist trust of destination from tourists' perception perspective, and uses the empirical data to verify. This study can provide guidance for the destination tourist trust system construction.

In relationships, trust makes relationships more intimate. For tourism destinations, trust allows visitors to feel good about their destination, and to enhance the positive perception of the tourism destination image. Trust is a factor that matches the perceived destination image of a tourist (Marinao, Torre & Chasco, 2012). It can be concluded that there is a certain relationship between destination tourist trust and tourism image. General studies suggest that the better the image of a tourist destination, the higher the credibility of it (Marinao, Torre & Chasco, 2012). However, this study suggests that the degree of tourists trust to the tourist destination will also affect their perception of the tourist destination image in turn. Based on this, this study puts forward relevant assumptions and uses structural equation model to verify it, which further enriches the research of trust in tourism.

LITERATURE REVIEW

Tourist destination trust

Trust in the field of tourism research mainly in two aspects of tourism enterprises and tourism stakeholders, including online travel website trust and services trust, brand trust, interpersonal trust, tourists to travel agencies and government's trust etc (Kim, Chung & Lee, 2011; Razak, Marimuthu & Omar, 2014; Han, Bang Nguyen & Lee, 2015; Roy, Michael & Paul, 2017; Nunkoo, Ramkissoon & Gursoy, 2012; Nunkoo & Smith, 2013). Trust is a mechanism that can help people make choices in uncertain situations. That is to say, trust is an act of believe in choice, especially the act willingness in a certain way in the state of risk (Deutsch, 1960), including the ability trust, integrity trust and goodwill trust (Mayer, Davis and Schoorman, 1995). Trust is a very important question in the field of tourism, it is defined as the reliability of an important component of the destination from a tourist destination point of view, including honesty, kindness and competence, (Vásquez, Suárez & Biaz, 2005; Saxena, 2005). This study think trust is an cognitive attitude that expresses recognition towards various elements of tourist destinations, an emotional attitude that expresses preference towards the overall of tourist destinations, and a supportive behavioural tendency. Thus, this study defines destination tourist trust as: assess the extent to which tourist destinations are trusted by tourists based on the cognition, emotional attitude and behavioral tendency of tourists.

Tourists to the destination is a kind of social activity, and meanwhile start establishing a social relations. If you view this kind of social relations as a form of social exchange relationship, trust plays an important role in developing and sustaining this relationship. Because, according to social exchange theory, the exchange relationship is accompanied by certain risks and uncertainties during the formation process (blau, 1964), in addition, trust is a kind of effective means of reducing the perceived risk and uncertainty (Han & Hyun, 2013). For any relationship network, a certain level of trust is indispensable (Das & Teng, 1998), because it is the emotional basis of cooperation or the lubricant of promoting cooperation (Sztompka, 1999). In tourism, trust is a very critical driving factor (Nunkoo & Ramkissoon, 2011; Czernek, 2013), tourists are more likely to go to the destinations they think it's trustworthy and reliable (Roodurmun & Juwaheer, 2010). Trust is also a key factor in customer satisfaction and loyalty

(Kim, Chung & Lee, 2011), visitors develop emotional attachments to trusted destinations(Thomson, McInnis & Park, 2005).

There is less research on the tourist destination as a trust object although the problem of trust in tourist destinations is so important and prominent. Measuring dimension of tourist trust is the basis of research. Marinao(2012) has proposed a three dimensions model to measure destination tourist trust for the first time, including local residents, public institutions and private institutions .Yao Yanbo etc. (2013) developed a trust scale of tourists to the destination, including perceived kindness, perceived integrity and perceived ability, on the basis of the existing brand trust scale and combining with Mayer' (1995) study of trust dimension and details about tourism destination research. Choi (2016) has developed a scale of 9 dimensions to measure the tourists' trust degree to the shopping tourist destination, dencsuch as product, predictability and reputation atc. The trust of tourists to a particular destination is based on his recognition of destination integrity and reliability, this trust will be linked with tourists' perception of local residents, facilities, environments(Enrique Coro & Eduardo, 2017).Therefore, measure the tourist trust of the destination must be inseparable from the attitude of the tourists, which will have an important influence on the destination.The trust crisis in tourism has made the trust research more urgent. In particular, the academic community has a lack of detailed discussion on these issues, especially the impact of trust on tourist destinations.

Tourism destination image

The research on tourist destination image has been very thorough at home and abroad, including its definition and constituent elements, influencing factors, image design, image evaluation, positioning, marketing and communication. Image is the subject's perception of the object of the non-residence (Hunt, 1971), is a belief of the subject to the destination object (Crompton, 1979), including cognitive elements, emotion elements and the sum impression of destination (Gartner, 1986; Embacher, 1989).Tourist destination image is a spiritual emotion produced after the potential tourist obtains the rich information of the destination (Fakeye, 1991). There are two aspects of cognitive image and emotional image in general. The former mainly comes from the understanding of the destination and the latter is feelings based on the understanding (Baloglu, 1999).This study defines the destination tourism image as the sum of the tourism consumers' perceptions and impressions of the destination and the total self-image that the destination promotes.

The researchers have a long and continuous attention to the formation, the former cause and the consequences of tourism destination image(Chew & Jahari,2014).Tourist destination image is affected by various complicated factors,they can be divided into two categories: one is the individual factors of the tourists, such as the age and gender of the tourist, and the psychological quality of the tourists, etc. (Beerli & Martin, 2004; Martin & he, 2008), another is the external stimulation factors, such as travel brochures, postcards, etc. (Y ù ksel & Akg ù, 2007; Molina & Esteban, 2006).Due to the complexity and diversity of tourism market, researchers found that more and more factors influencing tourist destination image through more detailed and in-depth research, such as a large event, popular culture, tourism information quality, etc. (JuliusArnegger & MarcHerz, 2016; SoJungLee & BillyBai, 2016; Sung-EunKim, YoungLee & Shin, 2017). In addition, researchers have found that safety is a prominent constraint on travel (Kim & Chalip, 2004). Tourists' risk perception will influence the destination image (Sönmez & Graefe, 1998b), while trust can reduce the perception of risk, so there is a certain relationship between the tourist destination trust and the image.

There are many researches on the influence factors of tourism destination image, but the research on discussing the relationship between tourist trust and tourism image is less. Nevertheless, the tourism destination image is an important guarantee of sustainable development and its factors affected are many and complex. Introducing trust in tourism research and studying its relationship with tourism destination image, exploring whether the destination tourist trust impact on tourism image, which can provide theoretical reference for sustainable development of tourism destination and has the vital significance to the destination construction.

GROUNDING THEORETICAL MODEL OF TOURISM TRUST COMPOSITION

Grounding theory foundation work

This study selects three tourism destinations (Zhangjiajie, Phoenix Ancient City and Shaoshan) in Hunan Province as samples. Hunan Province is a major tourism province with many tourist attractions. Among them, the Wulingyuan of Zhangjiajie is a scenic area of 5A, which is also a natural heritage of the world. As a class 5A scenic spot, Shaoshan Tourist Area is the focus of red tourism development in Hunan Province, and it is the red tourist area of the state key construction. Phoenix Ancient City is a national historical and cultural city. These three destinations belong to different types of tourist destinations with different resource characteristics and development history.

Text information for analysis from Ctrip "TripColor" column, searching by the keywords "Zhangjiajie", "Phoenix Ancient City", "Shaoshan" respectively and a total of 8185 articles were retrieved. This study aimed at 2015-2016 period, only chooses travel notes released by individual travelers who are self-help and self-driving tours, and identifies whether the travel story is true or not, whether it records the personal experiences of tourists, and deletes the travel notes with advertisement promotion features and signs of plagiarism and reproduction obviously. In addition, the contents of the sample travel notes must be complete, which can reflect the detailed process of the whole travel activity, and have a clear expression of emotional inclination. After screening, 276 travel notes were selected as samples with a total of over 1 million words.

Further processing of 276 text contents. Deleting all content that has nothing to do with this topic, unifying the name of the same object in the text, merging a series of text content and saving the processed text in the format of the text file. At the same time, identifying and interpreting the text of each travel note, organizing the word categories and characteristics in the text carefully, categorizing the same kind of vocabulary, finding out the common features of the elements, and repeating the above steps uninterruptedly.

Grounding theory analysis of tourist trust composition

(1) open coding analysis

In this study, 43 concepts and 16 preliminary categories were formed through the uninterrupted repetitive interpretation, induction and summarization of data, concepts and categories. 16 primary categories include the regional features, reputation, regional advantages, environmental quality, service quality, product quality, management quality, cost value, function value, convenience value, cost performance, experience value, experience quality, concerning behavior, revisiting behavior, recommend behavior. The open coding example is shown in figure 1.

Figure 1
EXAMPLE ANALYSIS OF CODING PROCESS

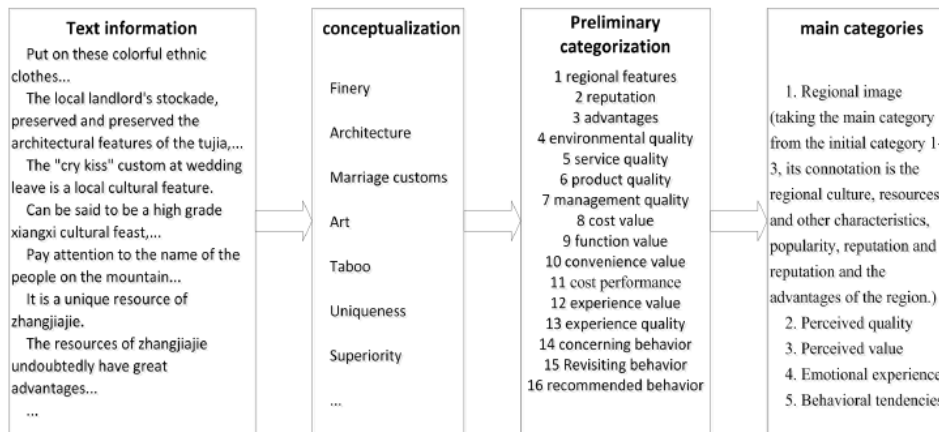

(2) Relational coding analysis

Paradigm model is analytical strategies Chinese scholars adopt more in the process of relational coding (Luo Qiuju & Chen Keyao, 2011), it develops the main categories and subcategories through the six aspects of causality, phenomena, mediation conditions, action/interaction strategies and results. Based on the principle of not missing any effective information, classifying the initial categories similar to the same category and extract all the initial categories belonging to the same category into a principal category through contrast and analysis of the implications. For example, the three preliminary categories of regional features, reputation and regional advantages are discussed in the analysis of "regional image", thus extracting the main category "regional image" from them. This research excavates five major categories finally through the paradigm model thinking, respectively for regional image, perceived quality, perceived value, emotional experience, behavior tendency, the five main categories constitute the tourism trust dimension. See figure 1.

Figure 2
GROUNDED THEORETICAL MODEL OF TOURISM TRUST COMPOSITION

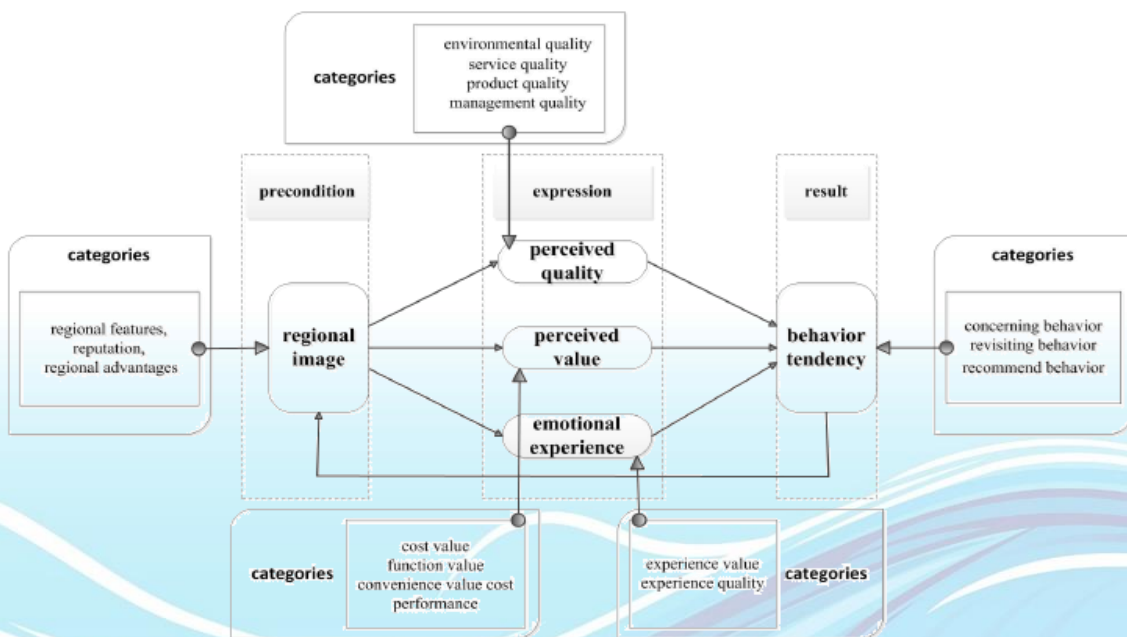

(3) Core coding analysis

In this study, the main categories of basic contains all necessary elements of "tourist trust form factor" through two stages of open coding and relational coding analysis, new information hasn't made much contribution to theoretical construction, so no longer need to new information. That is, the theory is basically saturated, so it can stop collecting data and start constructing the theoretical model.

After three coding analysis, finally, it forms a theoretical model of tourist trust which covers all text information by "regional image, perceived quality, perceived value, emotional experience, behaviour tendency", as shown in figure 2. The model can include all dimensions of the tourist trust and connect the whole process with the logic of the story line. Its connotation is: regional image is the precondition and foundation of tourist trust, perceived quality, perceived value and emotional experience are the expression of tourist trust and behavior tendency is the result.

Tourist trust evaluation index system

Based on the analysis results of Grounded theory, the index system of destination tourist trust evaluation is constructed. The main category of the dimension of the destination tourist trust constitutes the five criteria layers of the evaluation index system, while the sixteen preliminary categories correspond to the index layer of the evaluation index system. Thus, tourist trust evaluation index system is composed of five criterion layers and sixteen indicators. Among them, the five criteria layers including regional image (DI) B1, perceived quality (PQ) B2, perceived value (PV) B3, emotional experience (EE) B4 and behavioral tendency (BT) B5. The sixteen index layers include regional characteristics(C11), reputation(C12), regional advantages(C13), environmental quality(C21), service quality(C22), product quality(C23), management quality(C24), cost value(C31), functional value(C32), convenience value(C33), cost performance(C34), experience value(C41), experience quality(C42), concern behavior(C51), revisit behavior(C52), recommend behavior(C53).

Table 1
TOURIST TRUST EVALUATION INDEX SYSTEM

objective	criterion	index	Index interpretation and attributes
目的地旅游信任度A	DI (B1)	RC(C11)	Regional differences are unique to other places, including regional culture, resources etc.
		RR(C12)	The social impact of the region, including the area's popularity and reputation
		RA(C13)	The competitive advantage, including the comprehensive ability of the region, etc
	PQ (B2)	EQ(C21)	The quality of market social environment, including market, policy and social climate, etc
		SQ(C22)	The level of basic services, including social, scenic spots and supporting, etc
		PQ(C23)	The quality of tourism products, including the characteristics, diversity and reliability, etc
		MQ(C24)	Management methods and techniques, including basic management and modern technology
	PV (B3)	CV(C31)	The cost of travel for tourists, including prices, times, etc
		FV(C32)	The value of tourist product, including authenticity, practicality and quality, etc
		OV(C33)	The convenience when traveling, including the traffic and the visiting, etc
	EE (B4)	CP(C34)	The comparison between the cost and the benefit of the visitor
		VE(C41)	A subjective emotional value feeling in the travel experience, such as growth sense, etc
	BT (B5)	QE(C42)	A subjective emotional quality experience in the travel experience, satisfaction, security, etc
		CB(C51)	Tourist to focus on the destination, including the dynamic and development, etc
		RB(C52)	Tourists to choose to repeat the visit, revisiting one again or one more time
			CB(C53)

RELATIONSHIP MODEL OF TOURIST TRUST IMPACT ON TOURISM IMAGE

Relationship assumptions and model construction

Tourist trust variables, that are tourist trust evaluation index system of the five principles of layer which is encoded by grounded theory, are regional image, perceived quality, perceived value, emotional experience and behavior tendency respectively.

Regional image: the region is a complex, and each region has its own cognitive identity that distinguishes it from other regions. From the perspective of cognitive psychology, regional image is a kind of mental product, which can be understood as the imagination of people's general beliefs and impressions of the region and the integration of information in this region (Kotler & Gertner, 2002). Some scholars try to define the concept of regional image, and think that regional image includes uniqueness, reputation, superiority and reputation (Kleppe, Iversen & Stensaker, 2002), these characteristics reduce the perception of risk in the area. The region in this study refers to the city where the tourist destination is located, the scope of regional image includes regional culture, resources and other characteristics, regional popularity, reputation and reputation, and the advantages of the region. At the same time, regional image and tourism destination image are not the same image category, and the tourist destination image is only part of the regional image.

Perceived quality: Parasuraman et al. (1988) defined perceived quality as customer' view of the differences between expectations and actual situations of products and services, and developed a SERVQUAL service quality measurement scale has been widely accepted by scholars which includes five dimensions, they are reliability, responsiveness, assurance, empathy and tangible etc. Bitner & Hubbert (1994) defines it as a general impression of consumers' relative strengths or weaknesses in an organization and its services. Many studies have examined relationships between perceived quality and customer satisfaction, loyalty, and so on (Lee, Kim & Yong, 2011; Asshidin, Abidin & Borhan, 2016; Kim & Thapa, 2017). This study divided perceived quality into four aspects: environment, service, product and management.

Perceived value: Perceived value is the overall evaluation of the effect of consumers on product use on the basis of perceived giving and receiving (Zeithaml, 1988). Monroe (1990) suggested that perceived value as buyers' perception of value, Represents the trade-off between quality or benefit that they perceive in the product and sacrifice that They feel by paying the price. The result of this trade-off is their level of trust in buying products. A tourist destination can also be seen as a product. Some view value is a trusted choice (Mencarelli & Lombart, 2017), It can be said that tourists perceived value in the process of tourism will affect their trust in the destination to a certain extent.

Emotional experience: Emotional experience includes experience quality and experience value. Experience quality is a psychological result of tourists' participation in tourism activities (Altunel & Erkut, 2015) ,a more nuanced expression how do customers assess their experiences emotionally when they engage in consumer activity and interact with the environment, employees, other customers, customers' friends and other factors (Chang & Horng, 2010). Other researchers believe that experience quality is an emotional response to the social psychological benefits that tourists expect from them (Chen & Chen, 2010). Satisfaction is considered to be a variable that represents the quality of an experience (Seoho, Chon & Younghee, 2006). Experience value is a satisfying experience of education, enjoyment, socialization, or relaxation (Carù & Cova, 2003), the expression is in emotional, intellectual and other physical and mental feelings.

Behavior tendency: In the tourism environment, the degree of tourists' trust in the destination is reflected in their behavioral tendency, revisiting and recommendation are generally two important indicators in the study of tourism behavioral intention (Kozak, 2001; Yoon & Uysal, 2005). In addition, this study regards concerning behavior as a behavioral tendency. The loyalty of visitors is usually measured by their intentions (Baker & Crompton, 2000). They will continue to go to their destinations once again and are willing to recommend to others where they have been that indicating that they are very trusting of the destination. If there is no such trust, there will be no corresponding actions.

It has been proved that tourism image affects tourists' willingness of revisit indirectly through intermediate variables such as perceived value and satisfaction while effecting on the tourists' willingness of revisit directly (Chen & Tsai, 2007). Tourism image mainly influences the loyalty of tourists indirectly through the intermediary effect of satisfaction (Chi & Qu, 2008). Both perceived value and perceived quality are essential prerequisites for the visitors' satisfying experience, and the concept of satisfaction contains perceived quality (Chen & Chen, 2010), moreover, perceived quality has the greatest effect on satisfaction factors (Williams, 2015). In the process of tourism activities, more and more factors affect the tourists perception of tourism destination image, such as familiarity with the destination, Master quantity and information authenticity of the destination, tourist expectation and tourist preference difference, etc. All these factors can be attributed to the degree of tourist trust in the destination.

Based on the tourist trust dimension formed by the grounded theory, the existing research foundation in the literature and the purpose of combining this research, this study puts forward the following research hypotheses. According to the research hypothesis, construct the theoretical model of the structural equation of the influence of destination tourist trust on tourism image, as shown in Figure 3.

- H1: the dimension of tourist trust has a significant effect on tourism cognitive image
- H2: the dimension of tourist trust has a significant effect on tourism affective image

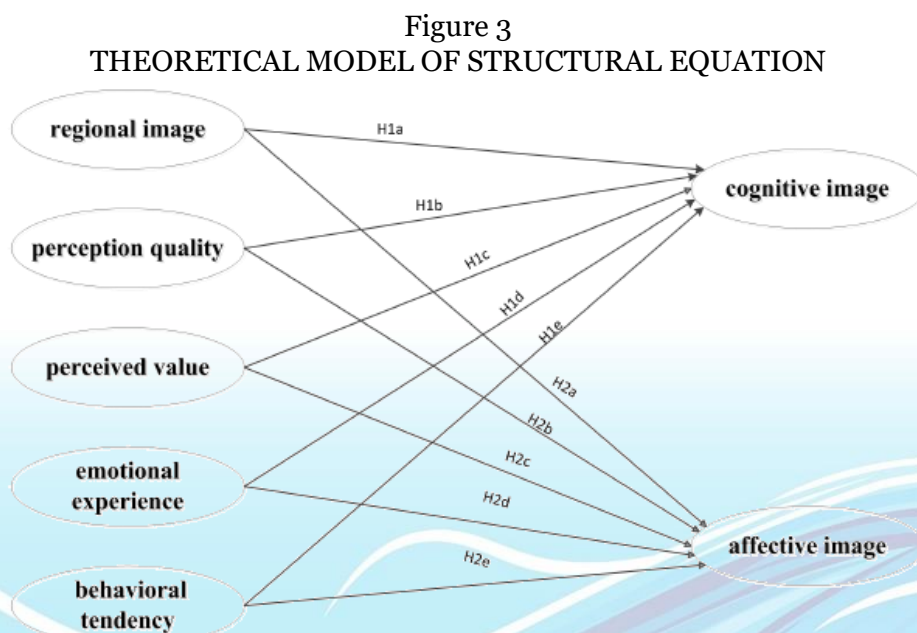

Research methods and data sources

According to the purpose of this study and the relevant theoretical basis, the questionnaire design is centered on the research topic in this paper, there are three main parts: tourist trust, tourism image and tourist demographic information. Tourist trust scale including five dimensions of regional image, perceived quality, perceived value, travel experience and behavior tendency, using regional features, reputation, regional advantages, environmental quality, product quality indicators such as basic item of the observed variables. The tourism image scale includes two dimensions of cognitive image and affective image as observation variables. The tourist trust item sources are integrated into the design of this study based on the research of McAllister (1995), Chen & Tsai (2007), Yao Yanbo & Chen Zengxiang (2013), et al. The tourism image item sources refer to the research of Beerli & Martin, (2004) and Zhang (2016), et al. All items were measured using the likert 5 point scale. From 1 to 5, they expressed "very disagree", "disagree", "uncertainty", "agree" and "very agreement".

This study investigates the tourists in zhangjiajie, fenghuang city and shaoshan in hunan province. Prior to the formal investigation, in order to ensure the operability of the questionnaire, the pre-investigation of small samples was first selected in shaoshan to further revise and improve the questionnaire .A total of 50 questionnaires were issued, 50 were recovered and the recovery rate was 100%, including 48 valid questionnaires and effective rate is 96%.It is found that the structure of the questionnaire is reasonable does not need to be changed, and the individual sentences need to be modified. The higher quality of the formal questionnaire after the modification of the statement is conducive to the accuracy of the empirical analysis results. The formal investigation adopts simple random sampling and systematic sampling method, the author personally sent the questionnaire to the tourists in the scenic spot. After the visitors were filled in, the author took it back personally. The recipients are mainly casual tourists and exclude team visitors to avoid the homogeneity of the questionnaire content. In this study, 300 questionnaires were distributed, 285 questionnaires were collected, and the recovery rate was 95%, among which 258 were valid questionnaires, and the effective rate was 91%.The sample size meets the minimum sample size and can be used for factor analysis and structural equation model analysis (Westland, 2010).The demographic characteristics of the sample are shown in table 2.

Table 2
DEMOGRAPHIC CHARACTERISTICS OF THE SAMPLE

characteristics	category	frequency	percentage	characteristics	category	frequency	percentage
gender	male	100	38.8%	profession	Civil servant	16	6.2%
	female	158	61.2%		Business administration	51	19.8%
age	Aged 14 and below	1	0.4%		Technical workman	34	13.2%
	15 to 34	221	85.7%		Service sales	33	12.8%
	35 to 59	33	12.8%		Individual business	31	12.0%
	60 and above	3	1.2%		student	18	7.0%
education	Primary	4	1.6%	1000 and below	75	29.1%	
	Junior High school	24	9.3%	1001 to 3000	16	6.2%	
	University and above	53	20.5%	3001 to 5000	70	27.1%	
passenger source	Hunan province	177	68.6%	Monthly income	5001 to 8000	96	37.2%
	outside	131	50.8%		8001 and above	45	17.4%
		127	49.2%				31

DATA ANALYSIS

This study only tested the travel trust scale because the tourism image scale has been more mature. In this study, the Cronbach's Alpha coefficient was used to check the reliability of the scale and the coefficients of each variable are calculated in SPSS20.0. At the same time, KMO sample measurement and Bartlett sphericity test were used to verify its validity. According to the accepted inspection standard in academia, the value of each variable is greater than 0.8, which means that the internal consistency of the measurement dimension is better, which also indicates that the scale has very good reliability. The sample KMO value was very close to 1, and the significance of Bartlett's value was 0.000, less than 0.01, and the test results indicated that it was suitable for factor analysis (Kaiser, 1974).

Table 3
Test results of reliability and validity

dimension	average	standard deviation	Cronbach's Alpha	KMO	Bartlett's value (Sig.)
Regional image	4.00	0.83	0.923		
Perceived quality	3.89	0.80	0.935		
Perceived value	3.94	0.81	0.929	.956	0.000
Emotional l experience	4.13	0.73	0.898		
Behavior tendency	4.01	0.79	0.890		

Table 4
Results of exploratory factor analysis of tourism trust dimension

dimension	index	factor loading	average	variance %	cumulative%
	PQ1 product quality	.769			
	PQ2 Management	.752			
Perceived quality	PQ3 market	.715			
B2	PQ4 Policies	.606	3.87	20.215	62.442
	PQ5 service level	.607			
	PQ6 social morality	.729			
Regional image	DI1 Resource characteristic	.813			
B1	DI2 cultural characteristic	.784	4.00	19.445	69.703
	DI3 popularity	.848			
	DI4 public praise	.719			
	DI5 regional advantage	.717			
Emotional l experience	AE1 knowledge and pleasure	.640			
	AE2 Fulfillment	.685			
B4	AE3 Comfort and satisfaction	.639	4.13	15.336	73.885
	AE4 security	.632			
Behavior tendency	BT1 recommended	.648			
	BT2 revisiting	.734	4.03	13.202	76.362
Perceived value	PV1 product value	.593			
B3	PV2 convenient	.550	3.81	10.395	78.593
	PV3 cost	.602			

P=0.000,CMID/DF=2.902,CFI=0.937,NFI=0.908,TLI=0.924,GFI=0.842,RMSEA=0.086,RMR=0.039

In this study, the method of orthogonal rotation was used to carry out factor analysis of the tourist trust scale. The researchers set the deletion threshold at 0.5 and the 5 components of tourist trust scale were obtained, The variance of each factor is not very different, and the

contribution rate of cumulative variance is higher (78.59%), factor analysis to extract the effect is better. It shows that the five dimensions of tourist trust based on theory analysis have high correlation. Five principal components were perceived quality, regional image, emotional experience, behavior tendency, and perceived value respectively which contains 6, 5, 4, 2, 3 items respectively, factors with a factor loading of less than 0.5 were eliminated, so the tourist trust measurement items become 20(table 4). Dealing with tourism image scale similarly and extracting two main components namely cognitive image and affective image, removing the factors that factor loading is less than 0.5, remaining 14 tourism image measurement items finally.

AMOS22.0 software was used to analyze the travel trust scale and test the relationship between variables directly, validate the rationality of the hypothesis model. The requirement to meet conditions is statistically significant for the estimated parameter values of the latent variables for all questions. The factor loading of all the indexes is very significant in this study, so the convergence of data is high. In fitting index calculation results, the p value reached significant level ($p=0.000$), $CMIN/DF=2.902$, NFI , CFI and TLI values were greater than 0.9, and $RMR=0.039 < 0.039$, $RMSEA=0.086 < 0.1$, which show that the model and actual data fitting degree is acceptable, the discriminant validity of the data reach the requirement(Hu & Bentler,1999).

Research results

This study uses the structural equation model to verify the research hypothesis. Taking the data into the hypothesis model and use AMOS22.0 software for analysis. The analysis results show that the factor loading of all indexes is very significant, indicating that the data convergence is high. In after correction model fitting index calculation results, the $CMIN/DF=2.724$, p value= 0.000 , and $GFI=0.826$, $NFI=0.905$, $TLI=0.937$, $CFI=0.937$, and $RMR=0.034 < 0.08$ and $RMSEA=0.082 < 0.1$, which shows that the model and actual data fitting degree can be accepted, the discriminant validity of the data reach the requirement. Therefore, it is considered that the model has better fitting effect and can be accepted.(Hu & Bentler, 1999).

Based on the study hypothesis and the statistical test of the variables, the results of the research hypotheses in this study are summarized(table 5).The results show that not all dimensions of tourist trust of destination have significant influence on the cognition image. The regional image and emotional experience had no significant positive effect on cognitive image ($p > 0.05$).So let's say $H1a$ and $H1d$ are rejected. The perception quality has a significant positive effect on the cognitive image, and the path coefficient is 0.476 ($p < 0.001$).The perceived value has a significant positive influence on the cognitive image, and the path coefficient is 0.161 ($p < 0.05$).The behavioral tendency has a significant positive effect on the cognitive image, and the path coefficient is 0.196 ($p < 0.05$).So let's say $H1b$, $H1c$, and $H1e$ are supported.

Not all dimensions of tourist trust of destination have significant influence on the affective image. The perceived quality, perceived value and behavioral tendency have no significant positive effect on affective image ($p > 0.05$), assuming that $H2b$, $H2c$ and $H2e$ are rejected. The regional image has a significant positive influence on the affective image, and the path coefficient is 0.155 ($p < 0.05$).The emotional experience had a significant positive effect on the affective image, and the path coefficient was 0.761 ($p < 0.001$). The behavioral tendency has a significant positive effect on the affective image, and the path coefficient is 0.325 ($p < 0.05$).So, the original hypothesis $H3a$ and $H3d$ are supported.

Figure 4
MODEL TEST RESULTS

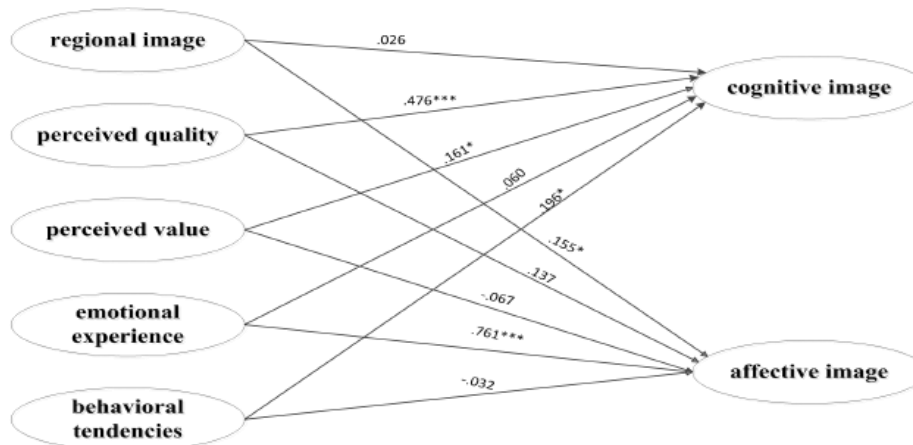

Table 5
RESEARCH HYPOTHESIS TEST RESULTS

hypothesis	variable relationship	Estimate	S.E.	C.R.	P	results
H1a	Cognitive image<---regional image	.026	.049	.527	n.s.	no
H1b	Cognitive image<---perceived quality	.476	.095	4.999	***	yes
H1c	Cognitive image<---perceived value	.161	.072	2.244	*	yes
H1d	Cognitive image<---emotional experience	.060	.113	.534	n.s.	no
H1e	Cognitive image<---behavioral tendencies	.196	.091	2.155	*	yes
H2a	Affective image<---regional image	.155	.076	2.029	*	yes
H2b	Affective image<---perceived quality	.137	.148	.923	n.s.	no
H2c	Affective image<---perceived value	-.067	.110	-.608	n.s.	no
H2d	Affective image<---emotional experience	.761	.187	4.062	***	yes
H2e	Affective image<---behavioral tendencies	-.032	.141	-.228	n.s.	no

P=0.000,CMID/DF=2.724,CFI=0.937,NFI=0.905,TLI=0.923,GFI=0.826,RMSEA=0.082,RMR=0.034

CONCLUSIONS AND DISCUSSIONS

This study takes three tourist destinations of Zhangjiajie, phoenix ancient city and shaoshan as examples, two main problems were solved.

On the one hand, researchers build destination tourist trust dimensional grounded theory model by the method of grounded theory through a series of encoding process from the bottom up as the data source with the travel notes of the study samples. It is different from the previous paths which inductive component dimension directly from the literature study (Marinao, Torre & Chasco, 2012;Yao Yanbo & Chen Zengxiang,2013).this study bases on the literature research and combines online textual data with empirical data analysis to verify that the resulting dimensions are more representative of the actual situation and more practical and operable. The grounded theoretical analysis shows that the destination tourist trust consists of five dimensions, namely, regional image, perceived quality, perceived value, emotional experience and behavioral tendency. Regional image is the premise of trust, Because it is the overall cognition that tourists get first before they travel of the area where the destination is located, including uniqueness, reputation, image edge and famous degree (Kleppe, Iversen & Stensaker, 2002)which will form a preliminary impression in tourists psychology as the basis of trust. Perceived quality, perceived value and emotional experience

are manifestations of trust which are the perceptions of the various aspects of the destination and the feeling of rising to the emotional aspect, this perception and feeling are the manifestation of trust in the destination. The behavior tendency is the result of trust, the behavior tendency of tourists can reflect the degree of destination trust of tourists, and the attention, revisiting and recommendation show that tourists trust the destination. This model illustrates a continuous process of visitors' trust in their destination and indicates that the trust generation is a process, and each element of the process is crucial. This five-dimensional model covers a wider range of three dimensional models than Marinao (2012), It is based on the three-dimension model developed by Yao Yanbo (2013) on the basis of brand trust, which focuses on the role of qualitative research. In addition, the evaluation index system of tourist trust based on this model includes 5 target layers and 16 index layers, which can provide a basis for measuring the destination tourist trust.

On the other hand, we explore and validate the acting path of all dimensions of tourist trust to tourist trust and its influence to the destination tourism image by means of structural equation model method, taking the visiting tourists of the study samples as the investigation object, collect data in the form of questionnaires. It can be seen that the five dimensions of tourist trust based on theory analysis have high correlation from the results of exploratory factor analysis. The results of qualitative research are verified by empirical research, which is also an innovation of this study. Structural equation model validation results show that in the five dimensions of tourist trust, in addition to the image of "regional" and "emotional experience", the rest of the three dimensions have significant positive influence on cognitive dimensions of tourism destination image, the influence from high to low in turn is perceived quality, behavior, and perceived value; In addition to the "perceived quality" and "perceived value" and "behavior", the rest of the two dimensions have significant positive influence on affective dimension of tourism destination image, the influence from high to low in turn to emotional experience and regional image.

In the field of national image research, destination is regarded as an experience product, while the destination image is regarded as the product image (Nadeau et al., 2008; Zhang & Cai, 2011). According to the "halo effect", national image is regarded as product evaluation clues by consumers, the more positive image of the country, the easier positive evaluation can get about product design, manufacturing, or manufacturing in this country (Zhang et al., 2017). Previous studies have shown that national image has a positive impact on product evaluation and product image (Costa et al., 2016; Hsieh et al., 2004; Lee et al., 2015; Wang, Li, Barnes & Ahn, 2012). The research on tourism also shows that national image has an important influence on tourism destination image. National image is a kind of regional image which takes the country as the main body, The study narrowed the area down to the city, regional image as a tourist trust factor, the results show that regional image has a significantly positive influence on destination affective image which consistent with previous research conclusion. However, the results of this study differ from previous studies in that regional images only have a significant relationship with the destination affective image, and there is no significant relationship with the destination cognitive image. This may be related to the basic characteristics of the interviewee (The respondents were mainly young women aged 15-34 (85.7%), and the group belonged to the more sensitive group). And it can be seen from the survey that the tourists' acquisition of the destination regional image is mainly introduced by friends and relatives (34.5%), which can easily lead to the emotional resonance of the tourists to the destination. Therefore, destination managers should pay more attention to the relationship between regional image and destination image. Perceived quality and perceived value are tourists' perception of all aspects of the destination during the tour, this feeling gives tourists a sense of trust in their destination. High perceived quality and perceived value bring high trust, which

make the tourism destination image is better in the tourists' mind. This is consistent with the previous research results (Lee, Kim & Yong, 2011; Chen, 2010). General studies believe that perceived quality and perceived value are prerequisites for tourists to be satisfied with products and services, and can further bring tourists loyalty (Asshidin, Abidin & Borhan, 2016; Kim & Thapa, 2017). In general, loyalty means trust, and that loyalty and trust can make tourists have a good image of their destination. Compared with perceived value, perceived quality has the greatest influence on satisfaction factors (Williams, 2015). The results of this study also show that perceived quality has more influence on cognitive image than perceived value. It shows that with the development of tourism and the improvement of the living standard of tourists, the demand of tourists is getting higher and higher, and more and more attention is paid to the tourism quality. Therefore, improving the quality and value of destination tourism is a task that destination should not slack off and keep following. At the same time, the results of this study show that there is no significant influence on the emotional image, which may also need to be the further attention of the researchers.

This study also confirmed that the emotional experience as an important dimension of tourist trust has no significant influence on cognitive image, but has a significant positive influence on affective image. The emotional experience expresses the quality and value of the tourists' heart directly in the travel experience, because it is an emotion that affects the destination affective image directly. Emotional experience is also related to satisfaction, and studies such as Chen (2010) show that the higher the quality of tourists' travel experience, the higher their satisfaction. Study of general tourism destination image on tourists' satisfaction will produce positive influence, but the conclusion of this study shows that tourist satisfaction on behalf of the emotional experience also can produce positive effects on tourist destination image. General research suggests tourism destination image produce positive influence on tourists' satisfaction, but the conclusion of this study shows that tourist satisfaction on behalf of the emotional experience also can produce positive effects on tourism destination image. The behavior tendency reflects the trust of the destination after the tourists visit, and the recommendation and the revisiting intention indicate that the tourists have a better cognitive image to the destination, and this study confirms this hypothesis. But this does not include concern behavior, possibly because concern behavior does not necessarily produce actual action, can not reflect the tourists cognition image perception of good or bad. In the study of tourists behavior tendency, recommendation and revisiting behavior are mentioned in generally (Kozak, 2001; Yoon & Uysal, 2005), and previous studies have shown that behavioral intention under the influence of tourism destination image perception, this study confirmed the behavior as an important dimension tourist trust, will also affect destination cognitive image. It is also important to note that the behavior of tourists only influences tourism cognitive image. An interesting thing that you can see from the research conclusions is that perceived quality, behaviour tendency, and perceived value of three dimensions have significant positive influence on cognitive image but have no significant impact on affective image. While, emotional experience and regional image of two dimensions have significant positive influence on affective image but have no significant influence on cognitive image. It can be seen that the cognitive image and affective image of the tourism destination are not synchronized. That is, the factors that affect the cognitive image and the factors that influence the affective image are not necessarily consistent.

General study consider that tourism destination image affect trust, good tourism destination image produce high trust (Marinao, Torre & Chasco, 2012), which consider a single relationship from the destination image to the destination trust. This study research the effect of tourist trust on tourism image through a reverse thinking, the conclusion shows that some dimensions of tourist trust have significant effects on tourism image, it is also suggests that

there is a two-way relationship between tourist trust and tourism image of destination and the two interact and tie each other. As a result, destination should take image and trust factors into consideration comprehensively. It is necessary to consider the influence of tourism image on tourist trust and the influence of tourist trust on tourism image, combine the two together and enhance the tourism image by improving the destination tourist trust, and establish the tourist destination trust image.

Through empirical research, this paper probes into the components dimensions of destination tourist trust and the impact of destination tourist trust on tourism image, some conclusions are obtained, but there are also some limitations. Firstly is the limitations of survey scope and survey sample, only three tourist destinations in hunan province were surveyed, the sample data is small. Although the three tourist destinations are representative, the conclusions of this paper still need to be tested on the basis of data from a larger sample of other tourist destinations. In addition, there are many controversies about qualitative research methods in academia, mainly focusing on its validity and reliability. Whether the conclusions of this paper have more general significance can be tested in the follow-up study. For example, some of the categories presented in this study can be conceptualized and manipulated, questionnaire survey and quantitative data analysis is used to test the variable dimension, thereby making effective adjustments and supplements.

REFERENCES

Abubakar,A.M. (2016). Does eWOM influence destination trust and travel intention: A medical tourism perspective. *Economic Research-Ekonomska Istraživanja*,29(1),598-611.

Choi,M., Law,R., & Heo,C.Y.(2016). Shopping destinations and trust–tourist attitudes:Scale development andValidation. *Tourism Management*,54,490-501.

Law, R. (2016). Book review:Trust, Tourism Development and Planning. *Tourism Management*, 53, 28-29.

Kim,T.T., Kim,W.G., & Kim,H.B.(2009). The effects of perceived justice on recovery satisfaction, trust, word-of-mouth, and revisit intention in upscale hotels. *Tourism Management*, 30(1),51-62.

Chang,K.C.(2014). Examining the effect of tour guide performance, tourist trust, tourist satisfaction, and flow experience on tourists' shopping behavior. *Asia Pacific Journal of Tourism Research*,19(2),219-247.

Mechinda, P., Serirat, S., & Anuwichanont, J., et.al. (2010). An examination of tourists' loyalty towards medical tourism in Pattaya, Thailand. *International Business & Economics Research Journal*, 9(1), 55–70.

Su,L., Hsu,M.K., & Marshall,K.P. (2014). Understanding the relationship of service fairness, emotions, trust, and tourist behavioral intentions at a city destination in China. *Journal of Travel & Tourism Marketing*, 31(8),1018-1038.

Kim,H.B., Kim,T.T., & Shin,S.W.(2009). Modeling roles of subjective norms and eTrust in customers' acceptance of airline B2C eCommerce websites. *Tourism Management*,30(2),266-277.

Chen,C.F., & Phou,S.(2013). A closer look at destination: Image, personality, relationship and loyalty. *Tourism Management*, 36,269-278.

Marinao, E., Torre,E., & Chasco,C.(2012). Trust in tourism destinations. The role of local inhabitants and Institutions. *Academia, Revista Latinoamericana Délelótt Administración*, 51(51),27-47.

Kim,M.J., Chung,N., & Lee,K.(2011). The effect of perceived trust on electronic commerce: Shopping online for tourism products and services in South Korea. *Tourism Management*,32(02),256-265.

Razak,N.S.A., Marimuthu,M., & Omar,A., et al.(2014).Trust and Repurchase Intention on Online Tourism Services among Malaysian Consumers. *Procedia-Social and Behavioral Sciences*,130(05),577-582.

Han,S.H., Bang,N., & Lee,T.J.(2015). Consumer-based chain restaurant brand equity, brand reputation, and brand trust. *International Journal of Hospitality Management*,50,84-93.

Roy,H., Michael,C.H., & Paul,W.B.(2017). Trust in local food networks: The role of trust among tourism stakeholders and their impacts in purchasing decisions.*Journal of Destination Marketing & Management*,In press.

Nunkoo,R., Ramkissoon,H., & Gursoy,D.(2012). Public trust in tourism institutions. *Annals of Tourism Research*,39(3),1538-1564.

Nunkoo,R., & Smith,S.L.J.(2013). Political economy of tourism: Trust in government actors, political support, and their determinants.*Tourism Management*,36(6),120-132.

Deutsch,M. (1960). The effect of motivational orientation upon trust and suspicion. *Human Relations*,13(05),123-139.

Mayer,R.C., Davis,J.H., & Schoorman,F.D.(1995). An integrative model of organizational trust. *Academy of Management Review*,20(03),709-734.

Vásquez, C. R., Suárez, A. L., & BÍaz, M. A. M. (2005).Trust as a key factor in successful relationships between consumers and service providers. *Service Industries Journal*, 25(1), 83-101.

Saxena, G. (2005). Relationships, networks and the learning regions: Case evidence from the Peak District National Park. *Tourism Management*, 26(2),277-289.

Blau, P. M. (1964). *Exchange and Power in Social Life*. New York:Wiley.

Han,H., Hyun, S.(2013). Image congruence and relationship quality in predicting switching intention: Conspicuousness of product use as a moderator variable.*Journal of Hospitality and Tourism Research*,37(3):303-329.

Das, T.K., Teng, B.S.(1998). Between trust and control: Developing confidence in partner cooperation in alliances. *Academy of Management Review*, 23(3), 491-512.

Sztompka, P.(1999). *Trust. A sociological theory*. Britain: Cambridge University Press.

Nunkoo, R., & Ramkisson, H. (2011). Power, trust, social exchange and community support. *Annals of Tourism Research*, 39(3), 1538-1564.

Czernek, K.(2013). Determinants of cooperation in a tourist region. *Annals of Tourism Research*, 40(1), 83-104.

Roodurmun, J., & Juwaheer, T.D . (2010). Influence of trust on destination loyalty: An empirical analysis the discussion of the research approach. *International Research Symposium in Service Management*. Mauritius: Le Meridien Hotel,24-27.

Kim, M.J., Chung, N., & Lee, K. (2011). The effect of perceived trust on electronic commerce: Shopping online for tourism products and services in South Korea. *Tourism Management*, 32(02), 256-265.

Thomson, M., McInnis, D., & Park, W. (2005). The ties that bind: Measuring the strength of consumers' emotional attachment to brands. *Journal of Consumer Psychology*, 15, 77-91.

Yao Yanbo,Chen Zengxiang, Jia Yue.(2013). Tourist Trustworthiness of Destination: Dimension and Its Consequence.*Tourism Tribune*,28(04),48-56.

Enrique, M.A., Coro,C.Y., & Eduardo, T.M., et.al.(2017).Determinants of trust towards tourist destinations. *Journal of Destination Marketing & Management*,in press.

Hunt, J. D. (1971). *Image—A factor in tourism*. America : Colorado State University.

Cromptom, J.L.(1979). An assessment of the image of Mexico as a vacation destination and the influence of geographical location upon the image. *Journal of Travel Research*,18(04),18-23.

Gartner, W. C.(1986). Temporal influence on image change. *Annals of Tourism Research*, (13), 635-644.

Embacher, J., & Buttle, F. A.(1989). repertory grid analysis of Aus-tria's image as a summer vacation destination. *Journal of Travel Research*,28(03),3-23.

Fakeye, P. C., & Cromptom, J. L.(1991). Image difference between prospective,first-time,and repeat visitors to the Lower Rio GrandeValley. *Journal of Travel Research*,30(02),10-16.

Baloglu, S., McCleary, K. W.(1999). A model of destination image Formation. *Annals of Tourism Research*,26(04),868-897.

Chew, E.Y.T. , & Jahari, S.A.(2014). Destination image as a mediator between perceived risks and revisit intention: a case of post-disaster Japan. *Tourism Management*, 40(2),382-393.

Beerli, A., & Martín, J.D.(2004). Tourists'characteristics and the perceived image of tourist destinations: A quantitative analysis-a case study of Lanzarote,Spain. *Tourism Management*, 25(5), 623- 636.

San Martín,H., Rodríguez, d.B.I.A.(2008). Exploring the cognitive-affective nature of destination image and the role of psychological factors in its formation. *Tourism Management*, 29(2),263-277.

Atila,Yù., ksela, & Olcay, Akgù.(2007). Postcards as affective image makers: An idle agent in destination marketing. *Tourism Management*, 28(3), 714-725.

Molina,A., & Agueda Esteban.(2006). Tourism brochures: Usefulness and image. *Annals of Tourism Research*, 33(04), 1036-1056.

Arnegger, J., & Herz,M.(2016). Economic and destination image impacts of mega-events in emerging tourist destinations. *Journal of Destination Marketing & Management*, 5(2),76-85.

Lee,S.J., & Bai,B.(2016).Influence of popular culture on special interest tourists' destination image. *Tourism Management*,52(2),161-169.

Kim, S.E. , Lee,K. Y., & Shin, S.I., et al.(2017). Effects of tourism information quality in social media on destination image formation: The case of Sina Weibo. *Information & Management*,54(6),687-702.

Kim, N. S., & Chalip, L. (2004). Why travel to the FIFA World Cup? Effects of motives, background, interest, and constraints. *Tourism Management*, 25(6), 695-707.

Sönmez, S. F., & Graefe, A. R. (1998a). Influence of terrorism risk on foreign tourism decisions. *Annals of Tourism Research*, 25(1), 112-144

Luo Qiuju, Chen Keyao.(2011). Study on the Growth Path of Privately-run MICE Enterprises Based on Grounded Theory-A Case of Guangya Exhibition.*Tourism Tribune*, 26(07),71-79.

Philip,K. & Gertner,D. (2002).Country as Brand,Product,and Beyond:A Place Marketing and Brand Management. *Journal of Brand Management*,9(4),249-261.

Kleppe, I. A., Iversen, N. M., & Stensaker, I. G.(2002). Country images in marketing strategies: Conceptual issues and an empirical Asian illustration. *Journal of Brand Management*, 10(1),61-74.

Parasuraman, A., Zeithaml, V. A., & Berry, L. L. (1988). SERVQUAL: a multiple-item scale for measuring consumer perceptions of service quality. *Journal of Retailing*, 64(1), 12-40.

Bitner, M. J., & Hubbert, A. R. (1994). Encounter satisfaction versus overall satisfaction versus quality: The consumer's voice. In R. T. Rust, & R. L. Oliver (Eds.),*Service qua-lity: New directions in theory and practice*. London: Sage Publications,72-94..

Lee, J. H., Kim, H. D., & Yong, J. K., et al.(2011). The influence of service quality on satisfaction and intention: A gender segmentation strategy. *Sport Management Review*, 14(1),54-63.

Asshidin, N. H. N., Abidin, N., & Borhan, H. B. (2016). Perceived Quality and Emotional Value that Influence Consumer's Purchase Intention towards American and Local Products. *Procedia Economics & Finance*,35,639-643.

Kim, M., & Thapa, B.(2017). Perceived value and flow experience: Application in a nature-based tourism context. *Journal of Destination Marketing & Management*, in press.

Zeithaml, V.(1988). Consumer Perceptions of Price, Quality and Value: A Means-End Model and Synthesis of Evidence. *Journal of Marketing* ,52(3),2–22.

Monroe, K. (1990). *Pricing: Making profitable decisions* (1st ed.). New York, NY: McGrawHill.

Mencarelli, R., Lombart, C.(2017). Influences of the perceived value on actual repurchasing behavior: Empirical exploration in a retailing context. *Post-Print*, 38,12-21.

Altunel, M. C., Erkut, B.(2015). Cultural tourism in Istanbul: the mediation effect of tourist experience and satisfaction on the relationship between involvement and recommendation intention. *Journal of Destination Marketing & Management*, 4(4),213-221.

Chang, T.Y., & Horng, S.C. (2010). Conceptualizing and measuring experience quality: The customer's perspective. *Service Industries Journal*, 30(14),2401-2419.

Chen, C.F., & Chen, F.S. (2010). Experience quality, perceived value, satisfaction and behavioural intentions for heritage tourists. *Tourism Management*, 31(1),29-35.

Seoho, U., Chon, K., & Younghee, R.(2006). Antecedents of revisit intention. *Annals of Tourism Research*, 33(4),1141-1158.

Carù, A., & Cova, B. (2003). Revisiting consumption experience: A more humble but complete view of the concept. *Marketing Theory*, 3(2), 267-286.

Kozak, M. (2001). Repeaters' behavior at two distinct destinations. *Annals of Tourism Research*, 28(3), 784-807.

Yoon, Y., & Uysal, M. (2005). An examination of the effects of motivation and satisfaction on destination loyalty: a structural model. *Tourism Management*, 26,45-56.

Baker, D. A., & Crompton, J. L. (2000). Quality, satisfaction and behavioral intentions. *Annals of Tourism Research*, 27(3), 785-804

Chen, C., & Tsai, D.(2007). How destination image and evaluative factors affect behavioural intentions?. *Tourism Management*,28(04),1115-1122.

Chi, C., & Qu, H.(2008). Examining the structural relationships of destination image, Tourist satisfaction and destination loyalty: An integrated approach. *Tourism Management*,29(04),624-636.

Williams, P., Nicholas, J. A., & Earl, N.(2015). Relationship quality and satisfaction: Customer-Perceived success factors for on-time projects. *International Journal of Project Management*,33(08),1836-1850.

Artigas, E.M., Montero, S.V., & Yrigoyen, C.C. (2015).Antecedents of tourism destination reputation: The mediating role of familiarity. *Journal of Retailing and Consumer Services*,26(06),147-152.

Tan, E.K., Wu, C.E. (2016). An investigation of the relationships among destination familiarity, destination image and future visit intention. *Journal of Destination Marketing & Management*,5(03),214-226.

Ge Xuefeng & Wu Chun you.(2010). Measuring the Differences of Rural Tourism Preferences: Based on Discrete Choice Model. *Tourism Tribune*,25(01),48-52.

McAllister, D.J. (1995). Affect and Cognition-Based Trust as Foundations for Interpersonal Cooperation in Organizations.*Academy of Management journal*,38(1),24-59.

Beerli, A. J., & Martín, H. S. (2004). Factors influencing destination image. *Annals of Tourism Research*, 31(3), 657–681

Zhang, H. M., Xu, F. F., Leung, H. H., & Cai, L. P. (2016). The influence of destination country image on prospective tourists' visit intention: Testing three competing models. *Asia Pacific Journal of Tourism Research*, 21(7), 811–835.

Westland, J. C. (2010). Lower bounds on sample size in structural equation modeling. *Electronic Commerce Research and Applications*, 9(6), 476-487.

Kaiser, H.F.(1974). An index of factorial simplicity. *Psychometrika*, 39(1),31-36.

Hu, L., & Bentler, P. M. (1999). Cutoff criteria for fit indices in covariance structure analysis: Conventional versus new alternatives. *Structural Equation Modeling*, 6, 1-55.

Nadeau, J., Heslop, L., O'Reilly, N., & Luk, P. (2008). Destination in a country image context. *Annals of Tourism Research*, 35(1), 84–106.

Zhang, H. M., & Cai, L. P. (2011). Country image and destination image: Similarity and difference of concepts and possibility of integration. *Tourism Tribune*, 26(9), 12–18.

Zhang H, Wu Y, Buhalis D. (2017). A model of perceived image, memorable tourism experiences and revisit intention[J]. *Journal of Destination Marketing & Management*,in press.

Costa, C., Carneiro, J., & Goldszmidt, R. (2016). A contingent approach to country-of origin effects on foreign products evaluation: Interaction of facets of country image with product classes. *International Business Review*, 25(5), 1066–1075.

Hsieh, M. H., Pan, S. L., & Setiono, R. (2004). Product-, corporate-, and country-image dimensions and purchase behavior: A multicountry analysis. *Journal of the Academy of Marketing Science*, 32(3), 251–270

Lee, B., Ham, S., & Kim, D. (2015). The effects of likability of Korean celebrities, dramas, and music on preferences for Korean restaurants: A mediating effect of a country image of Korea. *International Journal of Hospitality Management*, 46, 200–212.

Wang, C. L., Li, D., Barnes, B. R., & Ahn, J. (2012). Country image, product image and consumer purchase intention: Evidence from an emerging economy. *Business International Review*, 21(6), 1041–1051.

Zhang, H. M., Xu, F. F., Leung, H. H., & Cai, L. P. (2016). The influence of destination country image on prospective tourists' visit intention: Testing three competing models. *Asia Pacific Journal of Tourism Research*, 21(7), 811–835.

IS HIGHER ATTENDANCE, THE BETTER? – EXAMINING THE IMPACTS OF MEETING SIZE ON ATTENDEES’ PSYCHOLOGICAL RESPONSES AND CONSEQUENCE BEHAVIOR

YING (TRACY) LU

University of Kentucky, USA

WEI WEI

University of Central Florida, USA

LAURIE WU

Temple University, USA

JASON SWANSON

University of Kentucky, USA

DONALD GETZ

University of Calgary, Canada

ABSTRACT

Is higher attendance, the better? There has been a lack of research in the event literature considering conference size as a factor influencing attendees’ experience. Additionally, extant event research has largely centered on cognitive or overt behavioral responses of attendees. While psychological or emotional behavior has been recommended as an essential measure for evaluating customer experience, studies related to psychological responses in the event setting is scarce. With a survey of 470 association conference participants, results this research showed that conference size has an impact on attendees’ perceived social anxiety with self-esteem and social identity as moderators. Consequently, attendees’ social anxious feelings affect their conference satisfaction and perceived ROI. Theoretically, this research introduced a new influential factor - conference size - to the research of attendee behavior and provided empirical evidence for the impact. Moreover, the findings promote the values of psychological behavioral dimensions in the study of attendee behavior. Social anxiety causes an unfavorable evaluation of a conference. Further, this research advocates for the importance of ROI as an outcome evaluation of conferences. Practically, increasing the attendance of conferences will not hurt the social anxiety feeling of attendees. The higher attendance the industry achieve, the better. It also suggests that strategies need to be developed to release tension at small-scale conferences.

Keywords: Conference size, psychological experience, social anxiety, conference satisfaction, ROI

INTRODUCTION

The whole event industry has devoted decades of efforts into boosting event attendance. Within budget, event professionals usually aim to achieve the highest attendance for various monetary (e.g., making profit through selling tickets, attracting sponsor revenue) and non-monetary reasons (e.g., increasing awareness) (Hall, O’Mahony & Viececi, 2010). There seems to be an assumption in both academia and industry that adding more attendees to an event would not affect the experience of other attendees at the event. Is higher attendance, the

better? There has been a lack of research in the event literature considering meeting size as a factor that influences attendees' experience.

The event industry does not always have a high attendance. It had witnessed a big growth of small-scale meetings from time to time, especially during 2008-2012. Given tighter corporate budgets, companies and planners started to reduce the size and duration of individual events in order to cut back the total expenses on transportation, accommodation, and food and beverage (Seli, 2009). According to a survey on key areas of meeting activity across five top convention destinations in the U.S., the time period between 2008 and 2012 has seen a growth in small events - both in attendee size and duration. Specifically, up to 50% of all meetings are hosted by groups of 0-50 people in 2012 (Active Network, 2013). A survey of planners, buyers and hotel suppliers based around the world further pointed out that the decreased meeting size has been notable worldwide (Green, 2011). How attendees behave differently at different scales of events remained unknown in both industry and academia. Without empirical evidence, it is hard for meeting professionals to make adjustments in event management accordingly. The effect of meeting size on attendee experience has not been empirically examined.

While previous literature of attendee behavior studied attendee motivation (Bauer, Law, Tst, & Weber, 2008; Severt, Wang, Chen, & Breiter, 2007), satisfaction (Bauer et al., 2008), behavioral intention (Severt, et al., 2007), brand trust and perception (Lee & Back, 2010), event services (Breiter & Milman, 2006) and event destination from perspective of attendees (Lu & Cai, 2011), the psychological response as an essential component of human behavior has been largely neglected in the event literature (Wei, Lu, Miao, Cai & Chen, 2017). To fill out these research gaps, the purpose of this research was to examine the effects of meeting size on attendee experience in the context of association conferences. From perspectives of social anxiety, this research was to 1) investigate how conference size influence attendees' social anxiety levels; 2) how attendees' self-esteem and social identity at conferences moderate the effects of conference size on social anxiety; and 3) how attendees' perceived social anxiety influences their satisfaction with conference attendance and perceived return- on-investment (ROI) of the event.

LITERATURE REVIEW

Social anxiety

Social anxiety is a common psychological behavior. It results from the prospect or presence of personal evaluation in real or imagined social situations, in which people are or might become the focus of attention of others, as when they are engaged in a conversation, giving a speech, etc (Schlenker & Leary, 1982). Such social interactions carry the prospect of interpersonal evaluation: people making judgments of one another. The study of social anxiety has received much of its impetus from the theoretical work of Schlenker & Leary (1982), who defined the effect within the context of self-presentation and impression formation. Schlenker & Leary (1982) described social anxiety as the state created when a person is motivated to make a certain impression on an audience, either real or imagined, but doubts that this impression can be made.

Social anxiety essentially inhibits behavior. It may, for example, bring about disengagement - withholding of communication (Daly & Stafford 1984), breaking of eye contact (Leary, 1983) or replacement of meaningful communication with innocuous sociability (Leary, 1983). Leary et al. (1987) provided evidence that social anxiety is associated with a passive and self-

defensive style of verbal behavior in personal interaction. When undergoing a high level of social anxiety, individuals tend to avoid social interactions, report that they talk less, are more worried and less confident about social relationships (Watson & Friend, 1969).

Social anxiety at meetings

In a meeting setting, attendees likely experience social anxiety because they are frequently engaged in a conversation, giving a speech, or being the focus of attention of other attendees at various social activities. These social activities are usually one of the major purposes of attendees attending meetings (Lu & Cai, 2011). The situations could produce social anxiety to different degree. Additionally, one's intention to engage in impression management activities can be stronger when one holds salient social goals and perceives that certain self-presentation behavior can lead to the realization of these social goals (Geen, 1991). For the purpose of socializing and networking, attendees' motivation to present a desired image is expected to be activated and prominent at a meeting. Social anxiety can further affect attendees' overt behavior at meetings. Serving as a signal, the feeling of social anxiety warns people of avoiding social behavior that may not lead to the self-presentation goal (Baumeister & Tice, 1990; Leary, 1990), avoiding social situation, and even withdrawing from communication (Daly & Stafford, 1984).

Social anxiety and meeting size

Experimental evidence has strongly shown that individuals are influenced by the actions and expectations of others. When other people are the source of impact and the individual is the target, impact should be a multiplicative function of the number of other people. The larger the group size, the greater social impacts one will have, such as social anxiety. As the number of people increases, the feeling of social anxiety is expected to become stronger. Previous studies found that when more than a few persons are added to the audience, subjects' rating of anxiety was increased (Seta et al., 1989). This multiplicative relationship results in greater differences in the group due to factors such as age and status, for the larger audience sizes. For example, research found that anxiety increased more during public versus private speaking (Tillfors, Furmark, Marteinsdotir, Fischer, Pissiota, Långström, & Fredrikson, 2001). In contrast to small meetings, attendees at large meetings are likely to have more concerns over the outcomes of their self-presentation behavior due to the more complex group dynamic. Therefore, the presence of a greater number of attendees at larger meetings may facilitate one's engagement in impression management, and by the same token, increase one's sense of social anxiety. Meeting size may have a role in affecting attendees' feeling of social anxiety. Thus, it is proposed:

Hypothesis 1: Meeting size has a positive relationship with social anxiety.

Social anxiety, group identity and self-esteem

Extensive psychology literature has presented that one's social anxiety has close relationship with his or her sense of group identity and self-esteem (e.g., Lee & Robbins, 1998). Individuals with different feelings of group identity and self-esteem can experience different levels of anxiety in the same social situations. In other words, the influence of meeting size on the level of social anxiety may vary for attendees with different levels of sense of group identity and self-esteem. People with high levels of group identity or connectedness are more able to manage their own needs and emotions through cognitive processes (e.g., self-evaluation, social comparison; Tesser, 1991), and are thus less prone to anxiety (Kohut, 1984). Individuals with

greater group identity are able to readily identify with and participate with other group members in a particular social situation. Thus, it is hypothesized that:

Hypothesis 2: The influence of meeting size on social anxiety is different for attendees with different levels of perceived group identity.

Self-esteem is also among the strongest predictors of anxiety (Battle et al., 1988; Rawson, 1992). A great deal of research indicates that successful pursuit of self-esteem reduces anxiety and other negative emotions (Greenberg, Pyszczynski, & Solomon, 1986; Solomon et al., 1991). People with chronically high levels of self-esteem or whose self-esteem has been experimentally boosted show less anxiety (Greenberg et al., 1993). In contrast, people with low self-esteem experience greater social anxiety than those with high self-esteem (Leary, 1983). Furthermore, the intensity of these emotions correlated inversely with self-esteem (Haines et al., 1993). On the other hand, the sociometer theory maintains that people generally act in esteem-enhancing ways because socially desirable behavior increases the likelihood of social inclusion. Since self-esteem has a close relationship with anxiety, it might affect the relationship between meeting size and social anxiety. It was thus hypothesized that:

Hypothesis 3: The influence of meeting size on social anxiety is different for attendees with different levels of self-esteem.

Attendees' consequence behavior

Satisfaction is a consequential component in the buying process of consumers. It is consumers' aggregate evaluation of the performance of a product and/or consumption experience (Oliver, 1981; Yoon & Uysal, 2005). Satisfaction has long been a focal interest for practitioners and among academic scholars (Oliver, 1999), because satisfied consumers can generate long-term benefits for companies, including repeat purchase, attitude change, and brand loyalty. Previous studies are abundant in examining the concept and developing the measure of satisfaction. In a meeting setting, satisfaction is the onsite evaluation of consumption experience (Lu & Cai, 2007). Attendees perceive meeting participation as a potential satisfaction-producer. Attendees' satisfaction has become an important variable to examine in both academia and industry because it could further lead to attendees' behavior intention of attending meetings in the future (Severt, Wang, Chen & Breiter, 2007). Prior studies found that the degree of emotion or psychological feeling could determine one's subsequent behaviors (Kim & Moon, 2009; Russell & Snodgrass, 1987). Social anxiety as a negative emotion might have a negative influence on attendees' overall evaluation of a meeting. Attendees with various levels of anxiety at different scales of meetings are thus expected to report different satisfaction levels. The following hypothesis was therefore put forward:

Hypothesis 4: Social anxiety has an impact on attendees' satisfaction with their meeting experience.

Tracking ROI for business evaluation has been a long-time practice in many industries. In the meeting industry, satisfied attendees are certainly the top measurement of success. But meeting professionals recognize ROI as an important addition to the measurement and evaluation of meetings. It gives meeting professionals the information to make good and solid business decisions. ROI evaluation is a result-based process that brings a focus on results (Phillips, Breining & Phillips, 2008). It shows the contribution of meetings and connects meetings to business impact by pointing out the actual value for the investment on a meeting.

In the present research, the overall ROI perceived by attendees was thus studied. Since ROI is an important index of evaluating a meeting result, it is hypothesized that:

Hypothesis 5: Attendees' felt social anxiety has an impact on their evaluation of ROI of a meeting.

A framework of the impacts of meeting size on attendee psychological experience and consequence behavior is presented in Figure 1. It has six major constructs: meeting size, social anxiety, perceived group identity, self-esteem, satisfaction and perceived ROI. The present research proposed that meeting size influences attendees' social anxiety (H1) with group identity (H2) and self-esteem (H3) as moderators. Attendees' feelings of social anxiety can further influence their evaluation of a meeting experience, including satisfaction (H4) and perceived ROI (H5).

Figure 1
CONCEPTUAL MODEL OF THE IMPACTS OF MEETING SIZE ON ATTENDEE PSYCHOLOGICAL EXPERIENCE AND CONSEQUENCE BEHAVIOUR

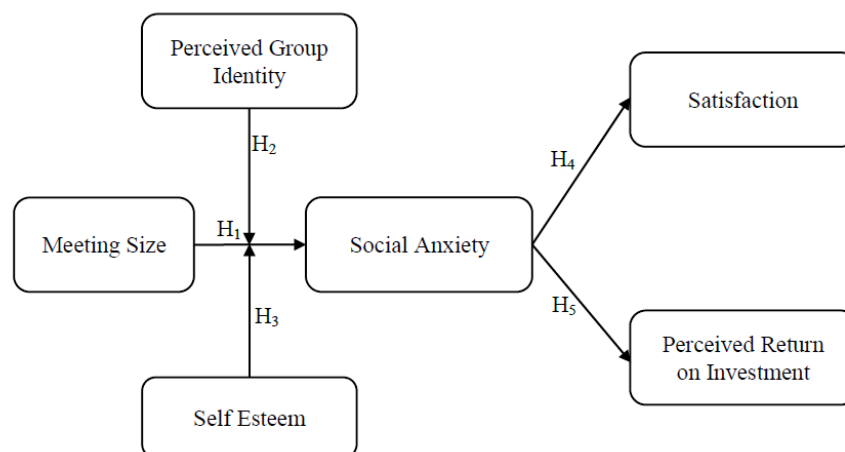

METHODOLOGY

Sample and data collection

This study employed a quantitative survey method to empirically test the effect of meeting size on attendees' meeting experience. A pilot study, consisting of 62 participants, was undertaken prior to the main study to clarify the design and coverage of the constructs in the instrument. The revised questionnaire was then used in the data collection for the main study. The recruitment of potential participants and the distribution of online questionnaires for the main study were administered with the help of a well-established professional research software company. A screening question was used to only select participants who had attended any association conferences in the past twelve months. In order to ensure better data quality, another filter question was used, asking whether the participant was a registered conference attendee. If the participant was an exhibitor, an invited speaker, or others, the survey will be terminated.

Questionnaire and measurements

The questionnaire consisted of four major parts. The first part instructed participants to recall the information of the most vivid association conference that they had attended in the past

twelve months. Basic information of the conference was recorded, such as the estimated number of attendees at the conference. Part two dealt with participants' psychological behavior at conferences, including social anxiety, group identity and self-esteem. Specifically, the dimension of social anxiety was measured by seven items adopted from studies of Mattick and Clarke (1998), Peters, Sunderland, Andrews, Rapee and Mattick (2012) and Safren, Turk and Heimberg (1998). Attendees' constructed group identity at the recalled conference was measured by using the scale from Bergami and Bagozzi (2000) and Jeong and Moon (2009). The dimension of self-esteem was adapted from Bergami and Bagozzi (2000) consisting of six items. Part three of the questionnaire was about attendees' overall satisfaction with the conference experience and perceived ROI of the conference.

Satisfaction dimension was adopted from the study by Lu and Cai (2011). The measurements of ROI were developed from Phillips et al. (2008). All items were measured on a seven-point Likert scale anchored by "strongly disagree" at 1 and "strongly agree" at 5. The last part of the questionnaire collected participants' basic demographic information.

Data analysis

A total of 470 questionnaires were completed and usable for data analysis. Descriptive analysis was used to generate a profile of the respondents. A regression analysis was first conducted to test the effect of meeting size on attendees' social anxiety (test H1). Then, Hayes' multiple-regression based PROCESS procedure was performed to test the moderation effects of perceived social identification (test H2) and self-esteem (test H3). Finally, hierarchical regression analysis was employed to examine the effect of social anxiety on satisfaction (test H4) and perceived ROI (test H5).

RESULTS

Descriptive analysis

Among 470 respondents, the gender composition of the sample was 48.5% male versus 51.5% female. Approximately 63.4% of the respondents were between the ages of 25 and 54. With respect to the educational level of the participants, 42.1% had a Bachelor's degree and 33.2% had a post-graduate degree. Concerning respondents' past experiences at association conferences, 69.9% of the respondents reported that they had participated in association conferences once to three times in the past five years. The remaining had attended association conferences more than 3 times. Regarding the size of the reported conferences, 44.6% were hosted for more than 500 attendees, 47.2% for 51-500 attendees, and 7.8% for fewer than 50 attendees. Concerning the scale of the conference, 12.3% were at a regional level, 28.7% were at a national level and 15.8% were at an international level.

Regression results (test of H1)

A regression analysis was first performed to test the effect of meeting size on social anxiety. Results of the analysis suggest that there is a significant but negative effect of meeting size on social anxiety ($\beta = -0.17$, $p\text{-value} = 0.00$), which was opposite to what was hypothesized. Results of the test are summarized in Table 1.

Table 1
REGRESSION RESULTS OF MEETING SIZE EFFECT ON SOCIAL ANXIETY

	Std. Coefficient	t	p-value
Constant		20.01	0.00
<i>Testing Variables</i>			
Meeting Size	-.17	-3.76	0.00
<i>Model Summary</i>			
	R	F	Sig.
	0.17	14.15	0.00

PROCESS results (Test of H2 and H3)

In this part of the analysis, two multiple-regression based moderation tests (PROCESS model 3) were sequentially conducted (shown in Table 2). Along with our theorization, the interaction effect was significant ($\beta=-0.12$, $t=-3.57$, $p\text{-value}=0.00$). To further examine the effect of meeting size along different levels of perceived group identification, simple slope tests were conducted following Spiller et al. (2013). Results revealed that the meeting size effect on social anxiety was significant for individuals with high levels of perceived group identification (i.e., participants scoring +1 SD on the perceived social identification scale) ($\beta=-0.31$, $t=-5.27$, $p\text{-value}=0.00$). Among individuals with low levels of perceived group identification (i.e., participants scoring -1 SD on the perceived social identification scale), the meeting size effect was non-significant ($\beta=-0.03$, $t=-0.66$, $p\text{-value}=0.51$). Thus, H2 was supported.

Table 2
REGRESSION TABLE FOR THE EFFECT OF MEETING SIZE X GROUP IDENTIFICATION ON SOCIAL ANXIETY

	Coefficient	S.E.	t	p-value	LLCI	ULCI
Constant	-0.23	0.82	-0.28	0.78	-1.84	1.38
<i>Testing Variables</i>						
Meeting Size	0.45	0.17	2.57	0.01	0.11	0.79
Group Identification	0.85	0.16	5.19	0.00	0.52	1.17
Meeting size X Group Identification	-0.12	0.03	-3.57	0.00	-0.19	-0.06
<i>Model Summary</i>						
	R	R-square	F	df1	df2	p-value
	0.31	0.10	16.47	3	466	0.00

Next, the second analysis was conducted with meeting size specified as the independent variable, self-esteem specified as the moderator and social anxiety as the dependent variable (shown in Table 3). Results show that the interaction effect was significant ($\beta=-0.10$, $t=-2.42$, $p\text{-value}=0.02$). Following Spiller et al. (2013), simple slope tests were used to examine the effect of meeting size across various levels of self-esteem. Meeting size has a negative effect on social anxiety among individuals with high levels of self-esteem (i.e., participants scoring +1 SD on the self-esteem scale) ($\beta=-0.25$, $t=-4.35$, $p\text{-value}=0.00$). Among individuals with low levels of self-esteem (i.e., participants scoring -1 SD on the self-esteem scale), the meeting size effect was non-significant ($\beta=-0.05$, $t=-0.88$, $p\text{-value}=0.38$). H3 therefore was supported.

Table 3
REGRESSION TABLE FOR THE EFFECT OF MEETING SIZE X SELF-ESTEEM ON SOCIAL ANXIETY

	Coefficient	S.E.	t	p-value	LLCI	ULCI
Constant	2.96	1.03	2.86	0.00	0.93	4.99
<i>Testing Variables</i>						
Meeting Size	0.38	0.22	1.70	0.09	-0.06	0.81
Self-Esteem	0.17	0.18	0.93	0.35	-0.19	0.53
Meeting size X Self-Esteem	-0.10	0.04	-2.42	0.02	-0.17	-0.02
<i>Model Summary</i>						
	R	R-square	F	df1	df2	p-value
	0.25	0.06	2.7205	10.40	3	466

Hierarchical regression results (test of h4 and h5)

Two hierarchical regression analyses were conducted to examine the additional effect of social anxiety on (a) perceived return on investment and (b) attendee satisfaction, on top of the effects of meeting size, social identification and self-esteem. Results suggests that, for both dependent variables, perceived return on investment and attendee satisfaction, social anxiety accounted for a significant increase in R² (for attendee satisfaction: Change in R² = 0.018, F(1, 465) = 15.10, p = 0.00; for perceived ROI: Change in R² = 0.005, F(1, 465) = 3.88, p = 0.05). These results suggest that social anxiety explains a significant amount of the variation in the two dependent variables beyond the variation explained by meeting size, social identification and self-esteem. Consistent with H4 and H5, the effect of social anxiety was negative for both attendee satisfaction ($\beta = -0.15$, t = -3.85, p = 0.00) and perceived return on investment ($\beta = -0.08$, t = -1.97, p = 0.05).

CONCLUSION AND IMPLICATIONS

The present research empirically tested how meeting size influences attendees' conference experience. Specifically, results showed that meeting size has an impact on attendees' perceived social anxiety, which is further moderated by self-esteem and group identity. Furthermore, attendees' felt social anxiety affects their meeting satisfaction and perceived ROI of the meeting. The findings have both theoretical and practical contributions.

Theoretical Contributions

First, the present research introduced a new influential factor - meeting size - to the research of attendee behavior. Previous studies have found various internal and external factors that influence attendees' behavior (Kim, Lee & Kim, 2012; Yoo & Chon, 2008; Wei, Lu & Hua, in-press), etc. The performance of these attributes can affect attendee behavior, such as satisfaction, decision-making for event participation and future intention. However, the impact of event size, an essential component in event system, had not been well understood in previous event literature. The present research offers empirical evidence, showing that meeting size influences attendees' social anxiety levels and ultimately affects attendees' satisfaction and perceived ROI of the event.

Second, the findings of the present research promote the values of psychological response in event attendee behavior research. Extant event research has largely centered on the cognitive or overt behavioral responses of attendees, such as attendees' evaluation of event performance (Severt, et al., 2007), motives for event participation (Mair, 2010), etc. Psychologists suggest that people's feelings or emotions determine what they do and how they do it (Donovan & Rossiter, 1982; Mehrabian & Russell, 1974). Results of the present research contributed to the event literature by showing that all the three tested psychological factors (i.e., social anxiety, group identity and self-esteem) are influential to attendees' conference experience. The findings are in accordance with previous research that psychological feeling could determine

one's subsequent behaviors (Kim & Moon, 2009; Russell & Snodgrass, 1987). The present research extended this line of thought to the event settings, emphasizing that negative feelings, such as social anxiety, cause a more unfavourable evaluation of an event.

Third, this research contributed to the event literature by establishing relationships of meeting size-psychological responses-outcome evaluation. The understanding of attendee behaviors was amplified with the demonstration of the model: external factors affect attendee emotions, which affect outcomes of event evaluation. The established framework revealed the complexity of attendee behavior and amplified the understanding of causal psychological factors and their effects on attendee behavior in event settings. Findings of the research also provided important building blocks for future investigation in this area of study.

Lastly, this research advocates for the importance of ROI as an outcome evaluation of meetings. The meetings and events function has experienced a need for increased accountability (Phillips, et al., 2008). While the planning staff may be comfortable and experienced with measuring input (e.g., number of attendees), reaction (e.g., satisfaction) and learning (e.g., the takeaways), executives are becoming increasingly concerned about the value of meetings and events, such as ROI (Phillips, et al., 2008). It is an important measure in addition to satisfaction and future intention. The present research is probably the first study to empirically examine this concept in relation to psychological constructs in a meeting context. This laid ground for future research on the evaluation of the outcome of meeting experience.

Practical contributions

The findings of the research also yield several important practical implications. The examination on meeting size draws attention to the importance of attendance management at conferences. A recent research by Wei et al. (2017) made recommendation for attendance management from a psychological perspective about selecting attendees for better attendee engagement. Following their suggestion, this research adds to the implication for small and large conferences. Specifically, results show that while increasing the conference attendance will not accelerate the social anxiety feeling of attendees, social anxiety becomes stronger as conference size decreases. This finding is especially important as more and more meetings are started to be held by groups of 0-50 people (Active Network, 2013) and the decrease in meeting size has become a global phenomenon (Green, 2011), thus calling for event organizers to recognize the salience of attendees' felt social anxiety at smaller events.

This research found that the felt social anxiety can further negatively influence attendees' satisfaction and evaluation of their meeting experience. Event organizers and planners are thus recommended to develop strategies and plan "interventions" to release attendees' psychological tension at small-scale conferences. For instance, event professionals can designate more comfortable seating options at various areas within the conference venue, such as the hallway and breakout rooms, to enable attendees to gather for more informal and organic interactions. This finding also encourages organizers of smaller events to strategize best practices to help attendees branch out and get more involved in conference activities. For example, designing the setting and atmosphere can spur attendees' social mood. Event organizers and the event venue are suggested to arrange relaxing music and lighting in event space for easing attendees' interaction anxiety. Interventions such as food and prompts (e.g., notecards) on the tables can also help attendees break the silence in an enjoyable way, thus building a foundation for spontaneous interactions to take place.

Finally, this research draws attention to the psychological or emotional experience of attendees at conferences. It was found that when one's self-esteem and group identity is high, social anxiety increases as conference size decreases. This may be because that when one strongly identifies with others in a group and has a high self-esteem, his or her pressure to project a desired image in a smaller group setting becomes bigger, thus increasing their anxiety. As event practitioners are urged to stage activities for helping attendees identify with other attendees and boosting their self-esteem, the findings of this research suggest that attendees' social anxiety may also increase when the event size is relatively smaller, further reducing attendee satisfaction. Appropriate interventions are thus necessary to ease attendees' anxiety. In addition to offering more social and learning opportunities, better food and conference services, meeting professionals need to pay greater attention to attendees' psychological traits and activities. For instance, event organizations could create a psychographic profile for their attendees, especially for repeat attendees and their members.

The psychographic profile may be used as a reference for customizing event activities for future events.

REFERENCES

- Ashforth, B.E., & Mael, F. (1999). Social identity theory and the organization. *Academy of Management Review*, 14(1), 20-39.
- Bang, H., Won, D., & Kim, Y. (2009). Motivations, commitment, and intentions to continue volunteering for sporting events. *Event Management*, 13(2), 69-81.
- Drag, R. M. (1969). Self-disclosure as a function of group size and experimenter behavior. *Dissertation Abstracts International*, 30(5-B), 2416.
- Geen, R. G. (1991). Social motivation. *Annual review of psychology*, 42(1), 377-399.
- Getz, D. (2008). Event tourism: definition, evolution, and research. *Tourism Management*, 29, 403-428.
- Gibb, J.R. (1951). The effects of group size and of threat reduction upon creativity in a problem-solving situation. *American Psychologist*, 6, 324.
- Gruen, T.W., Osmonbekov, T., & Czaplewski, A. J. (2007). Customer-to-customer exchange: Its MOA antecedents and its impact on value creation and loyalty. *Journal of the Academy of Marketing Science*, 35, 537-549.
- Guenzi, P., & Pelloni, O. (2004). The impact of interpersonal relationships on customer satisfaction and loyalty to the service provider. *International Journal of Service Industry Management*, 15(4), 365-384.
- Harris, K.J. (2007). Calculating ROI for training in the lodging industry: Where is the bottom line? *International Journal of Hospitality Management*, 26(2), 485-498.
- Hogg, M.A. & Vaughan, G.M. (2002). *Social Psychology* (3rd ed.) London: Prentice Hall.
- Jeong, H., & Moon, J. (2009). Virtual social identity development for customer electronic Word-of-mouth participation. *Proceedings of the 9th International Conference on Electronic Business*, Macau.

Lee, J.S., & Min, C. (in press). Examining the role of multi-dimensional value in convention attendee behavior. *Journal of Hospitality & Tourism Research*, in press.

Nicholls, R. (2005), *Interactions between Service Customers: Managing On-site Customer- to-customer Interactions for Service Advantage*, The Poznan University of Economics Publishing House, Poznan.

Olson, M. (1965). *The Logic of Collective Action* (pp.53-65). New York: Schocken. Phillips, J.J., Breining, T.M., & Philips, P.P. (2008). *Return on investment in meeting & events*. Burlington, MA: Butterworth-Heinemann.

Seli, G. (2009). Good things come in small packages. *Corporate & Incentive Travel*. Retrieved from <http://www.themeetingmagazines.com/index/tabid/1213/Default.aspx>

Sheppard, J. A. (1993). Productivity loss in performance groups: A motivational analysis. *Psychological Bulletin*, 113, 67–81.

Taylor, D. A., Altman, I., & Sorrentino, R. (1969). Interpersonal exchange as a function of rewards and costs and situational factors: Expectancy confirmation- disconfirmation. *Journal of Experimental Social Psychology*, 5, 324-339.

Taylor, R. B., De Soto, C. B., & Lieb, R. (1979). Sharing secrets: Disclosure and discretion in dyads and triads. *Journal of Personality and Social Psychology*, 37, 1196-1203.

Terry, D. J., Hogg, M. A., & White, K. M. (1999). The theory of planned behavior: Self- identity, social identity and group norms. *British Journal of Social Psychology*, 38, 225-244.

Widmeyer, W., Brawley, L., & Carron, A. (1990). Group size in sport. *Journal of Sport & Exercise Psychology*, 12, 177-190.

Williams, K. D., Harkins, S., & Latané, B. (1981). Identifiability as a deterrent to social loafing: Two cheering experiments. *Journal of Personality and Social Psychology*, 40, 303–311.

THE ROLE OF AN OFFICIAL WEBSITE FOR INTERNATIONAL CONVENTION CENTERS IN E-MARKETING ERA

XIUCHANG TAN

Institute for Tourism Studies, Macao

DON WU

Institute for Tourism Studies, Macao

ABSTRACT

The paper examines the role and importance of an official website for convention and exhibition centers (CECs). Qualitative method was employ in this exploratory study and a focus group (FG) discussion of 10 people was conducted. Stakeholder in the meeting industry, including event planners, destination marketing companies, event venue operator and service providers are invited for the FG. Social media marketing enjoy advantage of being more interactive, proactive, on-the- go and low cost. Facing with the ever dominating usage of social media for marketing, an official website is still considered as necessary and important for CECs. In contrast to the fragmented, confusion information released by social media, an official website is considered as important for corporate image building, reliability and richness of information. An CEC website serves as an information platform rather than a transaction platform. A venue contract involves extensive communication and negotiation about detail requirements for every event, and it's not a simple decision which can be made by one person at one moment.

Keywords: convention and exhibition center, website, marketing

INTRODUCTION

Destinations around the world have invested heavily in building convention and exhibition venues and facilities. Events, especially international events, are not only able to boom up local consumption on tourism activities, accommodation, and retail but also able to enhance destination awareness. Convention centers, or called convention and exhibition centers (CECs), are very important infrastructures for the meeting industry development in a city. It is a purpose-built complex which is “specifically designed to host meetings and conferences, whether they are the larger events for hundreds or even thousands of delegates or smaller, day and residential events” (Rogers, 2013). The core business revenue of a CEC is from the rental fee of event spaces and related facilities and services to various event organizers. The development and expansion of CECs in emerging markets is even more eye-catching. According to UFI, a nearly 40% leap of exhibition space was recorded in Asia Pacific region. Facing with hyper competition all around the world, CEC owners and operators are strived to find novel and effective ways to attract more events to use their venue.

The marketing tools and methods used to communicate with customers evolve from time to time. From late 1990s, the debut of Internet provides a more effective marketing platform as it enables instant information exchange, reservation and transactions without geographical and time constraints. An official website become a must for business promotion, communication with clients and even transactions. Later, the emergence of Web. 2.0, social media (e.g., facebook, twitter), review websites (e.g., tripadvisor.com), blogs, photo- and video-sharing platforms (e.g., Instagram, YouTube) allow consumers to comment and share feedbacks about a product/service in a convenient way. Marketing become a two-way

interaction instead of just a one-way information delivery. With the penetration of smart phone, people all around the world are connected through the virtual community created by social media even when they are on-the-go. In addition, compared with high cost of developing and maintaining an official website, creating pages and sharing information on social media is free of charge. With the features of easiness, convenience and low cost, social media marketing become popular among marketers.

With the ever dominating social media marketing, is it still necessary for convention centers to invest extensively in developing and maintaining an official website? What role the official website plays for a convention center for international marketing in an e-marketing era? This paper aims to solve the above mentioned research questions.

LITERATURE REVIEW

Convention and exhibition centers

The meeting industry has recorded a tremendous growth all around the world. According to the International Congress and Convention Association (ICCA), there is an exponential growth in the number of international association meetings in the last five decades. In 2012, approximately 23,000 meetings were held internationally (ICCA, 2013), twelve times compared to those in 1963.

With greater demand of meeting spaces, more and more buildings are built with a specific purpose to offer flexible venues for events of various size (Rogers, 2013). These purpose-built complexes are called “convention centers” or “convention and exhibition centers” offers exhibition halls and convention rooms, ball rooms specifically designed to host meeting and conferences, exhibitions, and other events ranging from hundreds and thousands of participants (Fenich, 2016; Rogers, 2013). Especially, for some large scale events that have special requirements on the capacity and other specifications of a venue, a CEC is the only choice for suitable venue spaces.

The boom of large number of CECs started from Europe and the US in the 1980s and 1990s, and then spread out to emerging marketing in late 20th century. According to UFI, the total space provided by convention and exhibition centers increased 12% globally from 2006 to 2011. In particular, a nearly 40% leap of exhibition space was recorded in Asia Pacific region. The rapid expansion of event spaces in the last decades lead to hyper competition. In addition, CECs are not only fighting for business with their counterparts worldwide, but also are competing with hotels with venues. New generation clients who are technology savvy with strong Internet attachment are also forcing CECs to reshape their tradition business strategy in the Internet era (UNWTO, 2014).

E-marketing

With the debut of Internet, Internet becomes a very important marketing tool and platform to provide information, communicate and interact with clients. According to Yuan, Fesenmaier, Xia, and Gratzner (1999), Internet offers a series of advantages, including overcoming the geographical boundaries, serving as a new channel for products and service, providing a faster and less expensive communication needs, and reaching wider, deeper and richer information channels. Internet plays a particular important role for international business, especially in tourism field where abundant information searching and transaction is needed (Williams & Palmer, 1999). In addition, the emergence of Web 2.0 and social media also allows users to

give comments and feedbacks to a certain product very conveniently. In traditional marketing era, marketers' job focuses on how to create impressive advertisements, and select a list of suitable media, such as advertising on TV, newspapers, magazines or outdoor billboards. In the Internet era, e-marketing strategies is not only to deliver message to attract and impress clients, but also to manage a two-way communication between marketers and consumer (Strauss, 2016). Depend on the different platform, e-marketing tools are categorized into: web marketing, social media marketing, and mobile marketing.

Web Marketing

Tourism is an information-intensive field, an official website is one of the most important and crucial platform to interact with customers in the e-marketing era (Buhalis, 2001). The overall quality of a website will influence the company's brand image, customer relationship building, customer satisfaction level and revisit or re-purchase intention (Bai, Hu, & Jang, 2007; Baloglu & Pekcan, 2006; Gan, Sim, Tan, & Tna, 2007). To better use the website as an effective marketing tool, websites are designed with different content, functions and features. Other than acting as an information platform, a website also includes different functions, such as e-booking, e-payment function and discussion forum to interact with customers. The experience of navigating on the website, that is the accessibility, speed of loading also affects the traffic of the websites. As a website is owned and developed by the company or organization itself, the marketers have much of the control of this marketing tool to deliver the planned message to the customers. It is the most important and basic marketing tool in the e-marketing context.

Social media marketing

The emergence of the Web 2.0 has enhanced consumer's power to a higher level in the market place. As the first generation of websites, such as official websites for many organizations, is more an information delivering and searching channel, Web 2.0 provides a convenient platform to give comments, upload photos and videos, and reviews. Web 2.0 include a wide range of electronic applications including social media (e.g., facebook, twitter), review websites (e.g., tripadvisor.com), blogs, photo- and video-sharing platforms (e.g., Instagram, youtube). Those user generated contents appeared on those websites are perceived to be more trusted as it reflect the true experience by the user instead of the message planned by markets(H.-Y. Wang, 2012). In addition, the emergence of social media has built virtual communities not only connecting people together disregard of their distances, but also provide a fast and low cost space and channel to distribute business information. Social media marketing is a marketing strategy built upon sharing through personal networks.

Mobile marketing

Nowadays, the application of smart phones makes a mobile phone into a fully functioned movable computer providing consumers high mobility without the restriction of a computer on the desktop (Kramer, Modsching, Hagen, & Gretzel, 2007; Neuhofer, 2012). This on-the-go function play a significant role in reshaping the travelers' behaviors, as all information searching, communication, purchasing decision can be done not only before the trip but also during the trip anywhere any time. Smart phone allows travelers to make last minute deals in their trip planning. For instance, instead of booking hotels before the trip, tourists can search and book hotels nearby when they arrive the destination. Many mobile APPs also consumer to search restaurants within a certain distance, so that consumers can choose the dinning place in the last minute. Other than trip planning, the use of smartphones also affects tourists' perception about their travelling experience (D. Wang, Xiang, & Fesenmaier, 2014). They feel

more connected with their friends and families by sharing the snapshots during the trip. On the other hand, with this instant sharing possibility, the Worth of Mouth (WOM) became more powerful and more difficult to control and handle. As if the tourist is not satisfied with the services and become emotional, the Worth of Mouth will be spread out immediately.

With the fast development of the MICE industry, numerous events are held or rotate to different destinations every year. Long distance selection of event venues becomes a new but common challenge to event planners. Hence, information searching about event venues in the Internet is a very important preliminary and screening process for venue selection. According to ICCA, there were over three million searches for facilities in the Internet in 2002 (ICCA,2003). A research by German Convention Bureau also predicts that almost all information will be accessed by the majority of people in the developed countries through Internet, which in return will significantly influence the meetings and convention operations (GCB, 2013).

METHODOLOGY

As an exploratory study, a qualitative approach was adopted in this study. Qualitative method allows researchers to collect rich data from words, contents and image to understand the cognition, affect, and intentions from the participants (Kaplan & Maxwell, 2005). As respondents in a qualitative approach enjoy more flexibility, new perceptions and relations will be discovered. The researcher obtains and collects data from the participants (who have been carefully selected from the industry) who share their perceptions, perspectives, knowledge, and experiences on the phenomenon to gain an in-depth understanding and description of the subject. Therefore, qualitative studies are widely used in studies with an aim to describe and explain a phenomenon through the constructed reality of the informants (Guhari & Gronhanug; Miles & Huberman, 1994).

Focus group (FG) interviews were conducted in this study to obtain perceptions from different stakeholders. Unlike individual interviews, focus group allows the researcher to gain access to a number of respondents at the same time. The group dynamics in the FC interview provide an encouraging atmosphere for members to express their ideas and build on each other's thoughts and opinions. In addition, one respondent's perception might also trigger other's thoughts, and hence richer investigation might be achieved. According to Catterall and Maclaran (2007), FGs are suggested to be conducted based on the following guidelines: consist of no more than eight participants; last for about one-and-a-half hours; strangers are preferred among the group; group members with homogeneous persona characteristics are preferred. In this study, eight different stakeholders in the meeting industry were invited for the focus group.

The FG was conducted in July 2017 in Macau. In order to capture a wider range of opinions, the respondents included two from associations, three PCOs or DMCs, one convention bureau and one from an international convention center. To start with the discussion, a semi-structure list of questions was presented to the respondent. Questions include:1) Where do you get information about a CEC? 2) Did you check a CECs website when you are searching for event venues? 3) Do you think an official website is necessary for CEC to set-up official websites? 4) How important an official website is for a CEC? Why? During the discussion, the researcher acted as a moderator encouraging discussion, ensure everyone got a chance to express their perceptions. In order to create a more relaxed discussion environment for the respondents to express their ideas, the focus group was not recorded. But field notes were

taken by the researcher. At the end of the focus group, all respondents were invited for the verification of the key points and notes.

FINDINGS AND DISCUSSIONS

Respondents profile

A total of 10 respondents participated in the FG discussion. The group includes four event planners who have experiences in planning and operating different event, ranging from exhibitions, meetings, competitions, festival events; two representatives from two associations who are organizing meetings and other events for their member every year; two Destination Marketing Companies (DMC); two service providers in the meeting industry, with one design and construction service provider and one logistics provider; one manager from a CEC. All respondents have working experience in working in the meeting industry.

	Business type	Working experience	Experience in meeting industry	Gender	Age
1	Event planner	>10	>10	F	40s
2	Event planner	6-10	6-10	F	30s
3	Association representative	>10	>10	M	40s
4	Event Planner	>10	>10	F	50s
6	DMC	6-10	6-10	M	30s
7	DMC	1-3	1-3	F	20s
9	Service provider	1-3	<1	F	20s
10	CEC operator	>10	>10	M	40s

Necessity of a CEC official website

Most of the respondents agreed that in terms of distribution and receipt of information, social media is much more convenient and instant. As people are getting more attached to mobile devices, visiting a website through a desktop becomes less convenient when compared to getting information through the APPs in a mobile phone. In addition, social media usually includes a “notification” function which alerts social media users when new information or thread is posted.

Information distribution in social media is more proactive to users, while information updated in a website is passively “await” the users to find and notice. However, all respondents in the FG discussion agree that an official website is still a “must” for a CEC. More details will be discussed in the following sections.

Corporation image

Although social media enjoy features of “fast”, “convenient”, “proactive” and “interactive”, its image as a personal social networking tool embedded in people’s mind. In contrast, a company’s website served as an “official” platform in the internet world. Compared with the zero cost of creating a page in a social media (such as facebook, twitter or wechat), developing a website normally needs investment and outsource to a professional company. Hence, having an official website is also a very important symbol of company’s web identity. To some extent, companies without official websites are more likely to be perceived as less powerful or less influential companies in the business world. It is similar that companies who have its own office building tend to be big enterprises, while companies with small offices or even work at home are usually perceived as small or home business. Convention and Exhibition Centers are important infrastructures which involved high capital investment. Different from consumer purchasing, booking an event venue is actually a corporate buying behavior. Therefore, an

official website is still worth and necessary for the image of the CEC. A website is not only for information distribution, but more importantly it is an important image building tool.

“It (official website) is quite important for convention centers. Booking an event venue is a business to business negotiation between an event planning company and us.”

“Yes, browsing a website is not as convenient as log into a social media. But a website builds a more “official” image in the industry.”

Perceived Reliability

As discussed in the above section, social media allow marketers to release information and communicate with consumers anywhere anytime. More attractively, information can be distributed to large group of users at no cost as long as the post trigger sharing in the virtual community. Mass information distribution, which previously is only affordable by big companies through mass media, become accessible for every to everyone, even an individual. Many eye-catching posts are generated by individual only for purposes of attracting attention and trigger circulation in the social media. As a result, people are getting numerous information in the virtual community which are difficult to distinguish whether it is reliable or fake. Therefore, official website in this situation acts as an important platform for information verification. People tend to trust information provided in an official website, only information shown in the company’s website are considered as official and reliable. The cost of building and maintaining a website enhance the barrier for fake information generation and distribution.

“People get confused by information from social media. They need to find a way to verify the truthiness of the information.”

Richness of information

Although social media offer free space (e.g facebook page) for information sharing, the editing format is not as flexible as a website. Furthermore, the space for information is limited in some social media. For example, twitter only allow 140 characters for every tweets. However, description of a CEC’s products and services are complex. Key business of a Convention and Exhibition Center is to offer event venues and related supporting services to event planners. Detail description are needed for specification of all venues available, capacity for different type of events, audio and video equipment, electricity, translation facilities, ambience of the venue, etc. In addition, various pictures, charts, virtual tour are commonly used for better presentation of the venue and facilities in a CEC. Obviously, information release in social media are somehow quite limited and fragmented. Website is a better option for CEC to present rich information in a more systematic and organized way.

Information platform

Choosing an event venue is a complex decision making process, which include five steps: convention preplanning, site selection analysis & recommendation, site selection decision, convention held and post-convention evaluation (Crouch & Ritchie, 1998). It is a holistic evaluation of the venue’s technical specifications, large budget, and multiple negotiations with the venue operator. Event site selection involve extensive information searching, analysis, comparison, short listing, and site inspection. While social media is more interactive and

proactive in reaching consumers, a website is a more appropriate platform for extensive information searching and gathering about a CEC.

Travelers will book and pay a hotel room online when they browse the hotel's website. However, selecting an event venue is rarely a simple decision by one person at one moment. Different from consumer consumption, selecting a venue is normally a corporate buying behavior which is much more complicated than consumer consumption (Chen 2006, Crouch, 1998, Huang, 2012). It is affected by many stakeholders from different levels and involves substantial analysis. Furthermore, a venue rental contract is not only about venue space, but usually a package of use of space, service and equipment in the venue. While the requirements of every event are different, negotiation of the venue package and prices is conducted before the final transaction is settled. Hence, a CEC's website seldom serves as a transaction platform, but more importantly a promotion and information platform.

"It's not realistic for an event planner to place order on-line. It's quite different from booking a hotel room. The requirement of every event is different. Lots of communication and negotiation is done before final contract is settled."

CONCLUSION AND LIMITATION

Marketing tools and methods evolve much faster with the development of Information Communication Technology in recent decades. Marketing strategies need be modified to adapt to the ever changing business environment and consumer behavior. Meanwhile, marketer should remain critical in choosing a mixture of suitable tools rather than just chasing the trend. Social media marketing, with its easiness, convenient and low cost feature, has become a very effective promotion tools. More and more corporations rely heavily or even purely on social media for marketing or even transaction, with some companies no longer invest in developing their websites. However, this pure social media strategy might not be applicable in CECs. An official website still plays an important role for CECs promotion and marketing. Products and services offered by CEC's are complex, which include a mixture of different event spaces, usage of facilities, and service. Transaction of booking a venue involve longer process which required comprehensive of communication and negotiation between the CEC operator (the seller) and the event planner (the buyer). Hence, a centralized formal platform for information sharing play significant role for building corporate image and gain trusts. In addition, CEC usually is an important infrastructure and sometimes a landmark of a city, for example the Hong Kong Convention and Exhibition Center. It also need a formal symbol of "existence" in the Internet world. Furthermore, the function of a CEC's website is different from hotels websites, travel website. Transaction of booking event venues will not be done on-line as if booking a hotel room. Therefore, this study make contribution both theoretically and practically. First, this study fills in the gap of understanding the role of the official website for a convention center. Current literatures regarding website studies in the tourism and hospitality field focus more on more consumer-oriented sectors, such as hotels, travel agents and transportations (Bai et al., 2007; Escobar-Rodríguez & Carvajal- Trujillo, 2013; Halpern & Regmi, 2013). Second, the insights from different stakeholders provide very good references for convention center management to develop their marketing strategies and to better allocate resources for business success.

Limitations shall be recognized in this study. First, due to time and resource constraints, only one FG was conducted for this research. Second, most of the respondents come from Macau. Perceptions from international stakeholders are not included. Third, although the importance

of the official website is recognized, the detail functionality of a CEC website has not been investigated. Future research is recommended in this regard.

REFERENCE

Bai, B., Hu, C., & Jang, S. (2007). Examining e-relationship marketing features on hotel websites. *Journal of Travel & Tourism Marketing*, 21(2-3), 33-48.

Baloglu, S., & Pekcan, Y. A. (2006). The website design and Internet site marketing practices of upscale and luxury hotels in Turkey. *Tourism management*, 27(1), 171-176.

Buhalis, D. (2001). Tourism distribution channels: practices and processes. *Tourism distribution channels: Practices, issues and transformations*, 7-32.

Catterall, M., & Maclaran, P. (2007). Focus groups in marketing research. *Handbook of qualitative research methods in marketing*, 255.

Crouch, G. I., & Ritchie, B. J. (1998). Convention site selection research: A review, conceptual model, and propositional framework. Paper presented at the *Journal of Convention & Exhibition Management*.

Escobar-Rodríguez, T., & Carvajal-Trujillo, E. (2013). An evaluation of Spanish hotel websites: Informational vs. relational strategies. *International Journal of Hospitality Management*, 33(0), 228-239. doi: <http://dx.doi.org/10.1016/j.ijhm.2012.08.008>

Fenich, G. G. (2016). *Meetings, Expositions, Events & Conventions: An Introduction to the Industry* (4th ed.): Pearson Higher Ed.

Gan, L., Sim, C., Tan, H., & Tna, J. (2007). Online relationship marketing by Singapore hotel websites. *Journal of Travel & Tourism Marketing*, 20(3-4), 1-19.

Halpern, N., & Regmi, U. K. (2013). Content analysis of European airport websites. *Journal of Air Transport Management*, 26, 8-13. doi: <http://dx.doi.org/10.1016/j.jairtraman.2012.08.006>

International Congress and Convention Association (ICCA).2013 A modern history of international association meetings 1963-2012

Kaplan, B., & Maxwell, J. A. (2005). Qualitative research methods for evaluating computer information systems *Evaluating the organizational impact of healthcare information systems* (pp. 30-55): Springer.

Kramer, R., Modsching, M., Hagen, K., & Gretzel, U. (2007). Behavioural impacts of mobile tour guides. *Information and communication technologies in tourism 2007*, 109-118.

Neuhofer, B. (2012). An analysis of the perceived value of touristic location based services: na. Rogers, T. (2013). *Conferences and Conventions 3rd edition: A Global Industry*: Routledge. Strauss, J. (2016). *E-marketing*: Routledge.

UFI (The global association of the exhibition industry), 2014. *Global exhibition industry statistics*

Wang, D., Xiang, Z., & Fesenmaier, D. R. (2014). Adapting to the mobile world: A model of smartphone use. *Annals of Tourism Research*, 48, 11-26.

Wang, H.-Y. (2012). Investigating the determinants of travel blogs influencing readers' intention to travel. *The Service industries journal*, 32(2), 231-255.

Williams, A., & Palmer, A. (1999). Tourism destination brands and electronic commerce: Towards synergy? *Journal of Vacation Marketing*, 5(3), 263-275.

Yuan, Y., Fesenmaier, D., Xia, L., & Gratzner, M. (1999). The use of Internet and intranet in American convention and visitors bureaus *Information and Communication Technologies in Tourism 1999* (pp. 365-375): Springer.

CORPORATE SOCIAL RESPONSIBILITY AND ITS IMPACT ON EMPLOYEE ORGANIZATIONAL IDENTIFICATION AND ORGANIZATIONAL COMMITMENT: A PERSPECTIVE OF CHINESE BRAND HOTEL EMPLOYEES

ZHAOHUI WANG

Anhui Normal University, China

SHUANGRONG LI

Anhui Normal University, China

JUAN LIU

Anhui Normal University, China

ABSTRACT

The purpose of this study is to explore the impact of hotel CSR on employees' attitude, behavior and the relationship between employees and corporation. Based on the perception of employees, this paper studies the CSR performance and its impact on organizational commitment and organizational commitment. Through the text analysis of domestic and international hotel group CSR report, to explore the characteristics of hotel CSR which is different from general enterprises. Try to develop hotel CSR perception measurement scale, construct employees perception model of hotel CSR and then establish the relationship model between CSR perception and organizational identification (OI), organizational commitment (OC). Through the model test and analysis, the findings of the study show that the perception of hotel CSR including five dimensions respectively: enterprise development responsibility (F1), market development responsibility (F2), employee development responsibility (F3), environmental protection responsibility (F4) and social development responsibility (F5). Among five factors, F1, F2, F3 and F4 has a significant positive effect on OI; F2, F3, F3 and F5 have a significant positive effect on OC; OI has a significant positive impact on OC. The results show that hotels actively carry out CSR activities to enhance employees' sense of belonging and identity to the organization, and then employees establish a good psychological contract with the organization to form a competitive advantage and improve the performance of the enterprise.

Keywords: Corporate social responsibility; Hotels; Employee perception; organizational identification; organizational commitment

INTRODUCTION

Modern enterprise is an important organizational form of material wealth production, and a subsystem of the national economic operation system. All the activities of enterprises are carried out in the social "ecological environment", and their development will be affected by the interests of the shareholders, managers, employees, consumers, suppliers, government, community and other parties (Hoje Jo et al., 2015). As an important strategic measure to balance the interests of all parties and establish a good public image (Mozes et al., 2009; Amy Mak et al., 2013), corporate social responsibility (CSR) has attracted more and more attention of enterprises and scholars. In the hotel industry, many enterprises, especially the international famous brand hotels, are actively involved in the practice of CSR for example Marriott International CSR focuses on moral principles, environmental protection, human rights protection etc; Hilton global CSR is mainly concentrated in the environment, community, employment; Accor hotel group vigorously promotes "earth 21 program" and so

on. Through the CSR practice activities and information disclosure, constantly expand the influence and credibility of the enterprise, forming lasting competitiveness. The research on corporate social responsibility mainly focuses on the impact of corporate social responsibility on economic performance (Babis Theodoulidis et al., 2017; Yinyoung Rhou et al., 2016; Seoki Lee, 2013; Lee and Park, 2009); from the perspective of managers, social responsibility fulfillment of tourism enterprises (Francisco et al., 2016; Vahideh Abaeian et al., 2014); from the perspective of consumer, the influence of social responsibility of tourism enterprises (Lujun Su et al., 2017; Eunil Park et al., 2017; Kucukusta et al., 2013; Lee et al., 2012); But less from the perspective of employees to explore the impact of corporate social responsibility on their psychological and behavioral (Hui Fu et al., 2014; Lee et al., 2012).

The hotel is a labor-intensive service industry, it is very important to deal with the relationship between the employees and organization. Modern Hotel enterprises advocate the "people-oriented" management model and pay attention to the work and life needs of employees. The hotel CSR not only bring external influences such as enhancing customer satisfaction and loyalty, improving customer repurchase rate (Patricia Martínez et al., 2013; Oppewal H. et al., 2006), enhancing social identity, promoting to establish a good brand image, bringing about more economic benefits and social benefits, and also has internal influences such as enhancing employee satisfaction, organizational trust, organizational commitment and reduce turnover rate etc (Lee et al., 2012). Only enhance the belonging of employees to the organization, to satisfy happiness and self-worth happiness of employees (Berg et al., 2003 ; Chan and Wyatt., 2007), the hotel fundamentally reduces the turnover rate and ensures that employees provide high quality products and services for a long time (Rupp et al., 2006). Although corporate social responsibility has been extensively studied from the perspective of employees, there is little attention in the impact of hotels' CSR on employees' psychological status (Ail et al., 2010; Rupp et al., 2006), such as organizational identification (OI) and behavior, organizational commitment (OC). This study attempts to develop a hotel CSR perception measurement scale based on employee perspective, and constructs the hotel CSR employee perception model to evaluate the CSR performance of Chinese brand hotels. Then, the relationship model between CSR and OI, OC was constructed. Through the validation of the relationship model, this paper aims to explore the impact of CSR on employees' organizational behavior.

LITERATURE REVIEW

CSR

The concept and definition of corporate social responsibility (CSR) has experienced a certain period of development and evolution (Carroll, 1979), but has not yet formed a conclusion. The concept of CSR was first proposed by Sheldon. He believes that CSR should be linked with enterprise managers to meet the needs of all kinds of people inside and outside the enterprise, and that CSR should include moral responsibility, and enterprise management needs to enhance community interests (Sheldon, 1923). The theory of Sheldon lays the core theory of CSR, which is stakeholder theory. Bowen brings forward the concept of CSR in "The Social Responsibility of Entrepreneurs". The enterprise must assume certain responsibilities and obligations at the same time in the pursuit of economic interests (Bowen H., 1953), which indicates that the research of modern CSR concept. In 21 Century, the concept of CSR has been further extended and developed. Devinney summarizes CSR related studies and finds that scholars have two views on the definition of CSR: the narrow point of view is that enterprises obtain economic profits under the premise of complying with the law as the only social responsibility of the enterprise; the general view of the enterprise as a social organization with

broader responsibilities and obligations, mainly on the responsibility of stakeholders, including the responsibility of the shareholders, employees, responsibility for environmental protection responsibility, consumer responsibility etc (Devinney.T.,2009).CSR is rich in connotation and related research are numerous, which is widely used by researchers is Carroll's "Pyramid" theory: including economic responsibility, legal responsibility, ethical responsibility and philanthropic responsibility, ethical responsibility and philanthropic responsibility which sits at the top of the Pyramid, at the bottom of the Pyramid economic responsibility and legal liability, but the four kinds of liabilities indispensable (Carroll,1991).With the rapid development of social economy, CSR research is gradually deepened, from the early concept of research gradually shifted to responsibility attribution and practical level, many scholars study CSR from the perspective of stakeholders. The enterprise has four kinds of stakeholders, such as community interest, organization benefit, mass media benefit and management interest (Henriques and Sadorsky,1999).From the perspective of different stakeholders to study CSR, such as CSR is depicted from three dimensions: cognition, language and behavior based on the managers' perspective (Basu ;Palazzo,2008);Research on the impact of CSR on economic benefits based on the interests of shareholders (Kang et al.,2010;Wang.,2010);From the perspective of employees' perception of CSR is divided into four dimensions: economic CSR, legal CSR, ethical CSR, philanthropic CSR (Lee et al.,2012).Although CSR content research based on the perspective of stakeholders has some limitations, but it has a very high reference significance for the specific CSR operation.

Hotel CSR

Since twenty-first Century, the theory research of hotel CSR began to develop, the general enterprise CSR theory is applied to the hotel CSR practice basically. Combined with the actual situation of the hotel industry, the main research direction is divided into the following: the first is to study the influence of CSR on Stakeholders' awareness, attitude and behavior from the perspective of hotel management. The researches show that the CSR of different star hotels and different formats has different effects on the awareness and attitude of stakeholders, such as the impact of CSR on customer perception of five star and four star hotels in Hong Kong (Deniz et al.,2013).the impact of CSR on the attitude and behavior of employees in Korean high-end hotels (Kim et al.,2017).Second studies on the relationship between Hotel CSR and hotel performance, the study shows that hotels can enhance short-term benefits and corporate value through active CSR investment (Rhou Y et al.,2016).There is a significant positive correlation between Hotel CSR practice and hotel economic performance, and CSR practice is beneficial to enhance Hotel economic profitability (Rodriguez; Cruz,2007).Hotel CSR practice can improve the occupancy rate and rate of return, so as to improve economic performance. Emphasizing environmental protection business philosophy and environmental behavior is one of the important criteria to influence business success (Tse ;Ng et al.,2003).In recent years, the research about the hotel CSR gradually from hotel financial performance to study behavior intention based on the perspective of employee, the research in this field mainly focus on job satisfaction, organizational trust, organizational commitment, employee turnover etc (Kim et al.,2017;Vinh Nhat Lu et al.,2016;Hui Fu et al.,2014;Lee et al.2012),and customer oriented hotel CSR research (Lee et al.2013), the ethical value of hotel management research (Gu and Ryan,2010).However, the number of studies in these areas is relatively small, and a strong theoretical framework has not yet been formed. The mechanism and conclusion of the study need to be further studied (Elkington J. 1997).About the hotel CSR measurement, some scholars applied the four-dimensional maturity scale proposed by Carroll to measure the hotel CSR research process (Lee et al.2012;Hui Fu et al.,2014;Kim et al.,2017),Some scholars try to develop CSR scale, such as Turker (2009) proposed a CSR measurement scale based on the

stakeholder theory, which has 22 items including environmental responsibility, product responsibility, employee responsibility, philanthropic responsibility and justice responsibility five dimensions. Based on the perspective of tourists perception, Deniz development of Hong Kong four-star, five star hotel CSR measurement scale, Deniz develops a CSR scale for four-star and five star hotels in Hongkong. It contains five dimensions: community development responsibility, vision and value, employee development responsibility, environmental responsibility and policy (Deniz et al.2013). Due to the diversification of the hotel business, in different geographical environment, affected by the local economic, political, cultural and other factors, the implementation of corporate social responsibility and the impact on the organizational staff attitudes and behaviour may be different (Sungbeen Park et al.,2017).With the continuous promotion of China's reform and opening policy, rapid economic development in China, improvement of residents' living standard, huge potential tourism market, the size of the hotel development significantly. The number of hotels in China ranges from 137 in 1978 to 18937 in 2015.The number of hotels in China ranges from 137 in 1978 to 18937 in 2015. Compared with the International Hotel CSR research and practice, the Chinese Hotel CSR started late, but also made corresponding efforts, such as supporting the development of "Green Hotel" (Peng et al.,2013), formulating relevant standards and carrying out practical activities (reducing waste output, using green environmental protection materials, etc.).China's research on CSR is relatively less, and most of the research on Hotel CSR focuses on the " Greens Hotel". Moreover, the research perspective is narrow, lacking full content of the hotel CSR research. Most of the hotel CSR research is to direct the research results of the manufacturing industry to the hotel industry, and lack of empirical research on the hotel industry CSR in the Chinese context.

Organizational identification

Organizational identification(OI) is rooted in Social identity theory. Social identity theory was first proposed by Tajfel and Turner (1979). Mael and Ashforth(1992) put forward the definition OI : employee's sense of belonging to the organization, and regard themselves as a member of the organization. OI represents emotional attribution, different from the trading relationship between the organization and employees, it affects the staff of the organization's cognition and work attitude and behavior. Grandey (2005) believes that organizational identification can help employees to act in accordance with the interests of the enterprise and actively participate in the work, so strengthening organizational identification is very important for the service industry. In the service industry, customer consumption process is the work process of employees, enterprises can not monitor the work status of employees, but by the employees themselves to decide whether to respond to customers in a positive state. Luthans (2002) believes that OI is the emotional expression of employees to organizations, not only a single exchange of interests, but also reflects the realization of employee self-worth, access to respect for other people's inner needs. It can be found that organizational identity is higher, in the face of difficulties and problems in the work, the more able to maintain and understand the heart of the firm to duty, consistent with the organization in mind and behavior, and actively strive to achieve organizational goals. Griffin (2007) refers to the research that further proves that in the non standardized and interactive experience of higher service field, such as hotels, tour guides and other tourist services scene, organizational recognition is the frontline staff good service level assurance.

Organizational commitment

Organizational commitment (OC) focuses on the relationship between employees and enterprises (Mathieu and Zajac,1990). OC generally refers to the strength of individual

members' identification and joining an organization. It is different from the contract of roles and responsibilities of employees and organizations, but a kind of psychological contract (Vinh Nhat Lu al.,2016). Pfeffer(1998) believes that the human centered strategy is the source of competitive advantage, because it is difficult to imitate, unlike technology, cost, and new product development. Mowday, Porter and Steers (1982) believe that OC is the embodiment of the relationship between employees and enterprises; Meyer and Allen (1990) proposed organizational commitment three factor model, including affective commitment, continuous commitment and normative commitment. Affective commitment, which refers to the staff of the organization emotional attachment is embodied in the sense of belonging and identity; continuance commitment refers to the willingness to remain in the organization; normative commitment refers to the employee to maintain employment sense of obligation(Meyer and Allen,1991).The difference between organizational identification and organizational commitment is that the former is from the self definition level of the members of the organization, the latter is the social exchange process that separates the individual from the organization psychologically (van Knippenberg and Sleebos,2006).O'Reilly and Chatman (1998) proposed the three types of relationship between the individual and the organization based on the study of the evolution of individual behavior intention, namely, internalization, identity and compliance, internalization refers to the organization's internal goals and values to make contact with consistent behavior, because the organization has identity refers to attractive goals and values, even if the organization's objectives and values have not been adopted as a tool of individual, individual behavior to obtain rewards of obedience; refers to the employees due to want to maintain relationships with organizations and behaviours (O'Reilly et al.,1986).

In summary, with the continuous deepening of CSR research, the research field from traditional manufacturing to modern service industry diffusion. As an important pillar industry of the tourism service industry, the hotel industry has accelerated its scale expansion and set off the upsurge of merger and reorganization of hotel enterprises.As the embodiment of the soft power of the hotel enterprise, CSR has been highly concerned by the academia and the industry. At present, most researches focus on the external effects of hotel CSR, such as corporate performance, public image, consumer perception behavior, community development, and less on the impact of CSR activities on employee attitudes and behaviors, and further deepen the relationship between employees and organizations. The influence of hotel CSR on employee behavior and attitude is mainly selected by organizational identification or organizational commitment as mediating variables to study the impact of attitude on behavior, OI and OC is rarely as a reflection of employee psychological activity and behavior intention variables, to explore the influence of CSR between the hotel employees' perception of organizational identity, organizational commitment and employee relationship, indirect Hotel CSR to reflect the influence relation between the employee and the organization. This paper attempts to develop based on the situation of Chinese Hotel CSR, CSR hotel construction staff perception model, explore the impact effect of each dimension of China Hotel CSR on organizational identity, organizational commitment and organizational identity and organizational commitment, and then understand the hotel CSR activities within the organization management role, to fill the research gaps, provide the direction for the follow-up study. This paper attempts to develop hotel CSR construction staff perception model based on the situation of Chinese Hotel CSR, explore the impact effect of each dimension of China Hotel CSR on organizational identity, organizational commitment and then understand the role of hotel CSR activities in the internal management of the organization, to fill the research gaps, provide the direction for the follow-up study.

HOTEL CSR EMPLOYEE PERCEPTION MODEL

Hotel industry is a comprehensive service industry, which has unique characteristics different from traditional manufacturing industry. In order to explore the characteristics of hotel CSR which is different from the general enterprise, this paper summarizes the hotel CSR perception dimension and content structure by analyzing the CSR report text of the international top 50 hotels. Based on the existing research results and the CSR practical activity development scale, the model is constructed.

Content analysis

According to the 2016 "HOTELS" recently released the 2015 annual "The Globe Hotel group 300" list, select top 50 hotel group as the research sample, to obtain CSR activities such as CSR Hotel Group's disclosure of the annual report (43), the CSR project, the contents of the report were analyzed using ROST Content Mining software, which initially Hotel CSR summed up the behavior dimension and content structure. The selected sample covers international hotel group and Chinese hotel group as follows: Marriott International, Hilton Worldwide holdings Inc, IHG, Wyndham Hotels and Resorts, Accor Group, Platinum Tao Group, Starwood Hotels and Resorts, Carsson Hotel, Hyatt Regency group, Reed group, Mei Li Ya Hotel Group, MGM Resorts International, Reell Hotel, Shangri-La Kaiser entertainment, BTG Jianguo, Jinling Hotel, Iberostar, CTS, hotels and resorts, an HNA group.

Through the ROST software to sample hotel group CSR report and project analysis of word frequency and semantic network, the international hotel group and China hotel group CSR are divided into environmental protection, community development, staff development responsibility, customer responsibility and charitable responsibility, legal responsibility, enterprise development, industry development, human rights etc. Among them, environmental protection is one of the most important social responsibility activities, including sustainable development, green business behavior, energy saving and consumption reduction, participation in environmental protection organization activities and so on; The second is the responsibility of enterprise development, including the economic performance of the enterprise, shareholder equity, enterprise continuity, supplier selection and so on; the employee development responsibility includes the training of talents, the long-term development of employees, the legitimate rights and interests of employees, the health and safety of employees, and the fairness of employee recruitment promotion; the philanthropic responsibility, including the protection of vulnerable groups such as women and children, social donation, organize volunteers to participate in community activities to improve the development of the industry; responsibility refers to comply with industry standards, committed to innovation, promote social responsibility activities throughout the development of the tourism industry; in addition, there are focused on the protection of human rights, the development of community.

Questionnaire design

Development of hotel CSR scale based on China's national conditions and strict compliance with scale development program:

First of all, to ensure the scientific nature of scale items. This scale comes from a large number of research results and the content analysis of the CSR report of 50 international hotel group. The CSR initial scale is derived from the four-dimensional theory of Carroll. The organizational identification scale was a single dimension scale proposed by Mael and

Ashforth (1992), and the initial scale of organizational commitment was derived from the three factor model of Meyer and Allen (1991). Through the analysis of the CSR report text of the international top 50 hotels, the paper summarizes the hotel's different from the general enterprise particularity, that is, the hotel development depends on the natural environment, community environment and human resources. Hotel industry CSR not only includes economic responsibility, legal responsibility, moral responsibility, but also includes employee care, industry development, community construction, charitable responsibility, customer responsibility, human rights and so on. According to the content analysis results of CSR report of international hotel group and the CSR project, the preliminary scale was revised. Secondly, pre investigation was conducted to improve the reliability and validity of the questionnaire. The investigation group at the end of July 2016 to invite 20 tourism management and related professional experts to fill in the questionnaire and proposed amendments. To modify the questionnaire, investigation team to conduct research in advance in the upscale Traders Hotel in early August, according to preliminary research results, the Questionnaire Revised and improved, and ultimately the formation of formal research measurement table.

Finally, the survey questionnaire mainly includes three parts. The first part is the CSR perception based on employees' perspective, that is, employees' evaluation of enterprise CSR practice; the second part is the measurement of employee organizational identity; the third part is the measurement of employee organizational commitment. The comprehensiveness of the questionnaire has been ensured. The scale of measurement in this paper mainly adopts Likert 5 scale to measure, 1 means very disagree, 2 means disapproval, 3 means general, 4 expresses approval, and 5 expresses very approval.

Investigation process and results

In the collection and analysis of hotel group CSR research report can be seen, compared to economical hotels and monomer hotels, high-end brand hotels pay more attention to CSR, carry out more social responsibility practice activities. The purpose of this study is to explore the relationship between CSR employee perception and employee organizational identification and organizational commitment, so the domestic brand hotel employees selected in this study are selected as the research object.

This research is mainly divided into two stages, the first stage is field research, the second stage is network investigation. The first phase of the survey was conducted in Suzhou Shangri-La Hotel in 2016 October. With the help of hotel human resources manager, employees were invited to fill in the questionnaires, and 130 questionnaires were sent out. 102 questionnaires were recovered, among which 71 were valid questionnaires. As the hotel staff basic configuration is one post one person, less leisure time, resulting in the amount of the questionnaire is not ideal. The survey group took the first phase of research experience, and the second stage adopted the network investigation. The survey group launched an electronic questionnaire on the media and mobile terminal platform, combined with the online payment reward function to improve the efficiency and reliability of the questionnaire filling. The network research invited employees working in different brands at home and abroad, through the circle of friends spread, and finally get 362 copies of valid questionnaires. A total of 511 questionnaires were collected in the two stages, with an effective questionnaire of 433 and an effective rate of 85%. The sample Hotel source covers more than 30 hotel brands at home and abroad, which shows that the sample has a certain representativeness.

The demographic characteristic of the respondents are presented in Table 1. Of the respondents, 48.5% were males and 51.5% were female. Hotel employees were mostly

unmarried, accounting for 59.6%, married accounted for 37.6%. In terms of age, the majority of the respondents were between 18 and 34 years old, accounting for 83.4%. On the level of education, the brand hotel pay more and more attention to the quality level of staff, the proportion of college degree or above is as high as 83.6%. On the job scale, the highest proportion of ordinary employees was 58.4%, middle managers accounted for 31.7%, and top management accounted for 9.1%, which was in line with the organizational structure of the hotel. The working department, the first line departments including catering and Housing Department which accounted for 60.7%, the second line departments including engineering, sales, administrative office, etc. which accounted for 39.3%. The proportion of ordinary employees is 58.4%, management staff including middle management and top management accounted for 41.6%. Demographic characteristics conform to the distribution of hotel staff, with a certain representation.

Table 1
DEMOGRAPHIC PROFILE OF THE RESPONDENTS (N=433)

	Frequency	Percentage (%)		Frequency	Percentage (%)
Gender			Education level		
Male	210	48.5	High school or below	71	16.4
Female	223	51.5	Bachelor's degree	341	78.7
Marital status			Master's degree and above	21	4.9
Married	163	37.6	Work department		
Unmarried	258	59.6	Front-line departments	263	60.7
Other	12	2.8	Second line department	170	39.3
Age group			Position level		
18-24	209	48.3	Ordinary employee	253	58.4
25-34	152	35.1	Middle managers	137	31.6
25-44	62	14.3	Top managers	43	10
45 or above	10	2.3			

Construction of perception model

Exploratory factor analysis (EFA)

Through the exploratory factor analysis of data, the hotel staff perception measurement model of CSR is constructed. To analyze the reliability and validity of the measurement model, the sample data of Cronbach's α is 0.973, show that the reliability of the scale is good. The Bartlett's test of sphericity was performed to compare the correlation matrix to an identity matrix. The statistical result of 4763.269 was significant at the 0.001 level, and the Kaiser-Meyer-Olkin (KMO) measure of sampling adequacy was 0.948. The results of both tests indicated that data collected on importance attributes were suitable for further factor analysis (Straub D., 1989; DeVellis R F., 1991).

Exploratory factor analysis with Varimax rotation was conducted on the data to identify the perceived performance factors related to the CSR efforts made by the China brand hotels. Attributes with factor loadings equal to or greater than 0.60 were retained as our sample size 433. Excluding the items that do not meet the requirements, 15 indicators of hotel CSR affecting employees' perception model are obtained. As shown in Table 2, the factor analysis extracted five perceptual dimensions: "enterprise development responsibility" and "market development responsibility", "employee development responsibility", "environmental protection responsibility", "social development responsibility". Altogether, these five factors explained 84.59% percent of the overall variance. Enterprise development responsibility The responsibility of enterprise development factor (mean=4.23) includes paying attention to

enterprise performance, implementing innovation development strategy and paying attention to enterprise public image. Market development responsibility factor (mean=4.30) includes maintaining market order, improving service system, adhering to the integrity management. Employee development responsibility factor (mean=4.16) includes creating a good working environment, providing employees with opportunities for development, and paying attention to the health and safety of employees. Environmental protection responsibility factor (mean=3.99) includes regular publication of energy consumption data, cleaner production, energy saving and consumption reduction, and purchasing of green environmental protection products. Social development responsibility factor (mean=4.09) includes regular release of CSR reports, establishing good community relations, and active participating in public welfare activities.

Table 2
FACTOR ANALYSIS RESULTS WITH VARIMAX ROTATION OF
EMPLOYEES' PERCEPTION OF CSR

	Factor loadings	Variance explained	Cumulative variance	Mean
Factor 1:Enterprise development responsibility		18.69%	18.69%	4.23
Pay attention to enterprise performance	0.777			
Carry out the strategy of innovation and development	0.748			
Focus on corporate public image	0.734			
Factor 2:Market development responsibility		18.02%	36.71%	4.30
Maintain market order	0.839			
Perfect service system	0.763			
Adher to the good faith management	0.759			
Factor 3:Employee development responsibility		16.88%	53.59%	4.16
Create a good working environment	0.778			
Provide employee development opportunities	0.751			
Pay attention to health and safety of employees	0.712			
Factor 4:Environmental protection responsibility		15.84%	69.43%	3.99
Publish energy consumption data regularly	0.749			
Save energy and reduct consumption	0.694			
Purchase green environmental protection products	0.608			
Factor 5:Social development responsibility		15.16%	84.59%	4.09
Publish CSR reports regularly	0.809			
Build good community relationships	0.677			
Take part in public welfare activities actively	0.612			

Confirmatory factor analysis (CFA)

According to the results of exploratory factor analysis, a total of 5 effective factors were obtained, namely, "F1 enterprise development responsibility", "F2 market development responsibility", "F3 employee development responsibility", "F4 environmental protection responsibility", "F5 social development responsibility". The maximum likelihood estimation method was used to validate the CSR staff perception measurement model, and the data model adaptation was analyzed, and the fitness index, path coefficient estimation and significance test were analyzed. The measurement model showed a satisfactory level of fit ($X^2=123.53$, $df=77$, $X^2/df=1.604$, $RMR=0.021$, $RMSEA=0.049$, $NEI=0.956$, $PNFI=0.708$, $CFI=0.986$, $IFI=0.982$, $RFI=0.987$). Through confirmatory factor analysis, the comprehensive correction model fit index, the overall model fit the internal structure index, fitness index reached the ideal level, verified the measurement model of exploring factor analysis, description of type CSR measuring model was established to build employee perceptions.

DEVELOPMENT OF HYPOTHESES

CSR and organizational identification

CSR employees' perception refers to the employee of the firm to perform CSR subjective feelings (Barnett M, 2007), relative to the real CSR practice, perceived CSR will produce more directly and more important influence on employee attitudes and behavior, therefore, from the perspective of employee perception, the study of the impact of CSR on employee attitudes and behavior also has practical value and reference value. Kim (2010) found that CSR participation and CSR perception were positively correlated with employee organizational identity, and then increased employee organizational commitment level. Through field survey, Peterson finds that the relationship between CSR perception and employee organizational identity is mediated by ethical responsibility perception. Gully (2013) finds that CSR perception affects organizational identification through the mediating effect of employee individual and organizational fit. In summary, employees perceived CSR will have a positive impact on employees' organizational identification. More specifically, the following hypotheses are offered.

Ha: Perceptions of CSR will have a positive effect on employees' organizational identity.

H1: Perceptions of enterprise development responsibility will have a positive effect on employee organizational identity.

H2: Perceptions of market development responsibility will have a positive effect on employee organizational identity.

H3: Perceptions of employee development responsibility will have a positive effect on employee organizational identity.

H4: Perceptions of environmental protection responsibility will have a positive effect on employee organizational identity.

H5: Perceptions of social development responsibility will have a positive effect on employee organizational identity.

CSR and organizational commitment

Hui Fu et al. (2014) pointed out that if the organization to carry out CSR activities is beneficial to themselves and the interests of the shareholders, employees will have a positive emotional identity such as a sense of pride and happiness, so as to establish a good organizational and emotional connection is emotional promise. Turker (2009) also proposed to fulfill the social responsibility of the enterprise will enhance their emotional promise. According to social exchange theory, employee commitment is the social group or organization based on the enterprise when employees have a good public image, will be enhanced between employee self-identity and strengthen the organization and contact, and help enterprises to gain greater respect in the community to carry out CSR, to establish a good corporate image (Maignan and Ferrell, 2011). Based on the theory of social exchange, there are some studies showing that CSR positively affects organizational commitment. Thus, we proposed that employees' perception of all five dimensions of CSR will have a positive influence on organizational commitment.

Hb: Perceptions of CSR will have a positive effect on employees' organizational commitment.

H6: Perceptions of enterprise development responsibility will have a positive effect on employee organizational commitment.

H7: Perceptions of market development responsibility will have a positive effect on employee organizational commitment.

H8: Perceptions of employee development responsibility will have a positive effect on employee organizational commitment.

H9: Perceptions of environmental protection responsibility will have a positive effect on employee organizational commitment.

H10: Perceptions of social development responsibility will have a positive effect on employee organizational commitment.

Organizational identification and organizational commitment

Enterprises help and support employees, employees will more identify with the enterprise, resulting in higher organizational commitment (Shore and Wayne,1993). Allen and Lynn (2003) the results show that the enterprise concerned employee behavior will reduce employee turnover rate, at the same time will reduce absenteeism, go-slow behavior, they think employees can get an identity from the enterprise sincere concern, so as to improve the staff of the organization of the affective commitment, increase positive behavior, improve attendance and reduce the turnover intention. Through the help of the enterprise, the employee will feel a feeling that he is an important member of the enterprise, and then reduce the job hopping and turnover behaviour (Wayne, Charles and Pamela, 2003). Enterprise's care and support to employees can enhance employee's organizational commitment (Bishop, Scott and Goldsby, 2005). Thus, we proposed that employees' organizational identification will have a positive influence on employees' organizational commitment.

Hc: Perceptions of CSR will have a positive effect on organizational identity.

H11: Employees' Organizational identification has a significant positive impact on employees' organizational commitment.

CONSTRUCTION OF RELATIONAL MODEL

Figure 1
CONCEPTUAL MODEL

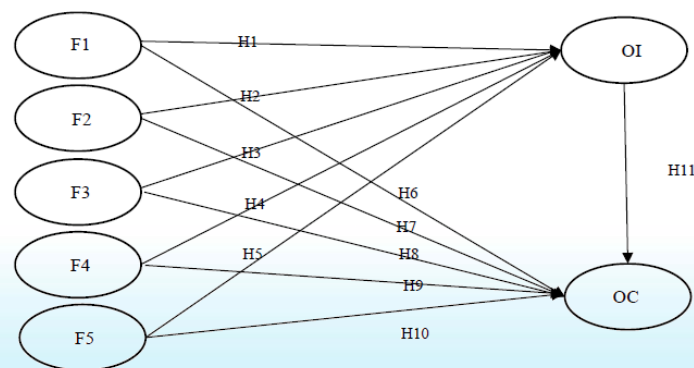

Conceptual model

Conceptual model (Figure 1) based on relational hypothesis. The contents are as followed: (1) Enterprise development responsibility, market development responsibility, employee development responsibility, environmental protection responsibility and social development

responsibility have significant positive influence on organizational identification. (2) Enterprise development responsibility, market development responsibility, employee development responsibility, environmental protection responsibility and social development responsibility have significant positive influence on organizational commitment. (3) Organizational identification has a significant positive impact on organizational commitment.

Assessment of the structural model

This paper assumes that the initial equation model contains measurement models and structural models, and explores the relationship between latent variables, belonging to the PAVLV model. The initial model contains five dimensions and latent variables of CSR: "W2 organizational identification" and "W3" organizational commitment". The five dimension of CSR is based on the hotel CSR perception model to determine which are enterprise development responsibility, market development responsibility, employee development responsibility, social development responsibility and environmental protection responsibility. Organizational identity includes six observation variables, which are "have a strong sense of self responsibility", "pay attention to the public image of enterprises", "self cognition of enterprise image", "the goal of enterprise is consistent with self-development", "Business success enhances employee pride", "Corporate failure enhances employee frustration". Organizational commitment includes seven observation variables, which are "learn in order to practise in an enterprise", "challenging work in an enterprise", "be keen on my job", "Have deep feelings for the enterprise I work for", "Willing to dedicate and work hard", "compared to other enterprises, the enterprise is better", "have high loyalty to enterprises".

Table 3
RELIABILITY AND VALIDITY TEST

Constructs and Variables	Standardized Factor loadings	CCR	AVE	Cronbach's α
CSR		0.929	0.725	0.876
Enterprise development responsibility	0.865			
Market development responsibility	0.793			
Employee development responsibility	0.859			
Environmental protection responsibility	0.861			
Social development responsibility	0.877			
OI		0.943	0.734	0.906
Have a strong sense of self responsibility	0.849			
Pay attention to the public image of enterprises	0.887			
Self recognition of corporate image	0.852			
The goal of enterprise is consistent with self-development	0.834			
Business success enhances employee pride	0.857			
Corporate failure enhances employee frustration	0.859			
OC		0.943	0.702	0.917
Learn in order to practise in an enterprise	0.813			
Challenging work in an enterprise	0.859			
Be keen on my job	0.809			
Have deep feelings for the enterprise I work for	0.898			
Willing to dedicate and work hard	0.880			
Compared to other enterprises, the enterprise is better	0.811			
Have high loyalty to enterprises	0.788			

All measures were subjected to reliability and validity analysis. Reliabilities were assessed using two indices: Cronbach's alpha coefficient and Composite Construct Reliability. Reliabilities of items ranged from 0.85 to 0.92 in Cronbach's alpha coefficient. Coefficient exceeding 0.70 are considered acceptable (Nunnally,1978).The Composite Construct Reliability (CCR) statistics also suggest reliabilities of the measures, all exceeding 0.6,which is a threshold for indicating reliability (Bagozzi and Yi,1988) .Validity of the measures were assessed using confirmatory factor analysis. Validity of the items using the average variance extracted (AVE) .The average variance extraction (AVE) of latent variables in each dimension was above 0.5(Churchill,1979;Fornell and Larcker,1981), indicating that the latent variables had good validity. Table 3 shows the results, which demonstrate evidence of reliability and validity of the measures.

The overall measurement model statistics show desirable measurement quality: χ^2 fit statistic=276.38 with 256 degree of freedom ($p < 0.001$); root mean squared error for approximation(RMSEA)=0.018; comparative fit index(CFI)=0.997; roor mean square residual(RMR)=0.031; χ^2/df ratio=1.080. Table 4 shows that all the indexes of the overall model fitness are at a good level, suggesting desirable measurement quality.

Table 4
GOODNESS-OF-FIT INDICES OF THE MODEL

Absolute fit measures		Incremental measures			Parsimonious fit measures		
RMR	RMSEA	NFI	RFI	CFI	PGFI	PNFI	PCFI
0.031	0.018	0.963	0.945	0.997	0.587	0.652	0.675

Hypothesis testing results

Table 5
STANDARDIZED PARAMETER ESTIMATES

Path	Standardized estimate	P 值 (<0.05)
H1 Enterprise development responsibility→Organizational identity	0.173	0.005
H2 Market development responsibility→Organizational identity	0.180	0.003
H3 Employee development responsibility→Organizational identity	0.273	***
H4 Environmental protection responsibility→Organizational identity	0.164	0.007
H5 Social development responsibility→Organizational identity	0.028	0.661
H6 Enterprise development responsibility→Organizational commitment	0.160	0.108
H7 Market development responsibility→Organizational commitment	0.335	***
H8 Employee development responsibility→Organizational commitment	0.521	***
H9 Environmental protection responsibility→Organizational commitment	0.534	***
H10 Social development responsibility→Organizational commitment	0.243	0.023
H11 Organizational identity→Organizational commitment	0.824	***

Testing of the hypotheses was done by examining the significance of the path coefficient. From hypothesis 1 to hypothesis 5, there addressed the impact of perceptions of CSR on employees' organizational identity. Only one hypothesis(H5) ($p > 0.05$) was rejected, the other four hypotheses (H1-H4) were supported. The impacts of enterprise development responsibility, market development responsibility, employee development responsibility and environmental protection responsibility were significant positive impact on OI ($p < 0.01$). Social development responsibility was not statistically significant at organizational identity. From hypothesis 6 to hypothesis 10, there were concerned with the relationship between perceptions of CSR and organizational commitment. The four hypotheses(H7-H10) were supported, but hypothesis 6

(enterprise development responsibility → organizational commitment) did not support ($p > 0.05$). Hypothesis 11 addressed the impact of organizational identity on organizational commitment, and this hypothesis was supported ($p < 0.01$). Table 5 shows the path analysis results and the test values.

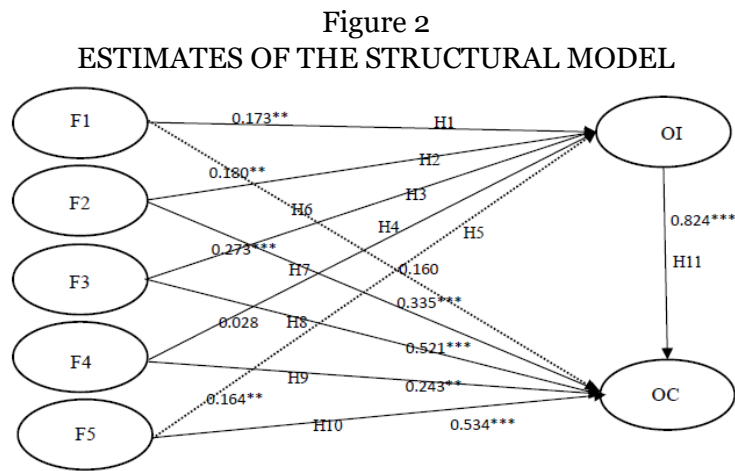

DISCUSSION AND IMPLICATIONS

CSR hotel employees' perception of the measurement model is different from manufacturing industry mature CSR model, it believes that economic responsibility and legal responsibility are the rigid requirements that enterprises must abide by. Corporate social responsibility refers to the contribution of enterprises to employees, customers, communities, and society, under the economic, legal and other bottom line. Based on the perception of employees, this paper puts forward the CSR theory model of hotel industry, which is divided into five dimensions: enterprise development responsibility, market development responsibility, employee development responsibility, environmental protection responsibility and social development responsibility. "Enterprise development responsibility" means that enterprises should adhere to business ethics, create economic value, carry out technological innovation, and pursue long-term development on the basis of the law. "Market development responsibility" represents that the hotel can provide customers with real, quality products and services on the basis of complying with the law. "Employee development responsibility" refers to the hotel in providing legal provisions for staff salaries and benefits, but also to the staff's career development and physical and mental health, and can provide special assistance to employees. "Environmental protection responsibility" aims to protect the environment, maintain natural harmony, and promote sustainable development. "Social development responsibility" refers to the participation in social public welfare activities and the establishment of good community relations, aimed at promoting the harmonious development of society.

In order to explore how Hotel CSR activities affect employee attitudes and behavior and the impact on employees and organizations, this paper constructs a model of the relationship between Hotel CSR employee perception and employee organizational identification and organizational commitment. Through the test of the model we can draw the conclusion that ①Hotel CSR has a significant positive impact on organizational identification, among which employee development responsibility has the greatest impact on organizational identification, followed by market development responsibility, corporate development responsibility and environmental protection responsibility, while social development responsibility has no

significant impact on organizational identification. From the employee's perspective, related to the vital interests of employees and staff development to create a good working environment, such as the responsibility to pay attention to employee development and employee health concern will enhance the well-being of employees in the organization, and identification of organizational identification has significant positive influence. Employees are the executors of enterprise practice activities, whose accept the service concept, culture, development goals normalization training more comprehensive responsibility for enterprise development related practice understanding, positive reflection of market enterprise development responsibility, corporate philosophy and corporate culture development responsibility, environmental responsibility will enhance their sense of pride and belonging thus the influence of organizational identification. Most of the decision-makers of hotel social development responsibility are the top managers of hotel, which lead to weaker perception of employees and less influence on employees' organizational identification.②Hotel CSR has a significant positive impact on organizational commitment, in which environmental protection responsibility and employee development responsibility have a great impact on organizational commitment, followed by market development responsibility and social development responsibility, while corporate development responsibility has no significant impact on organizational commitment. Enterprises pay attention to the work and life needs of employees, provide good working environment for employees, will enhance staff attachment to the organization, enhance the willingness to stay in the organization, reduce the turnover rate of hotel staff. By participating in social public welfare, charitable activities, practicing environmental protection obligations, providing customers with quality products and services, establish a good corporate public image, and enhance the "psychological contract" relationship between employees and organizations. In the process of practicing CSR, the hotel will have some negative effects because of improper public relations in crisis or not balance the interests of various aspects, thus affecting the trust of employees to the organization.③Organizational identification has a significant positive impact on organizational commitment, which supports previous research results. Hotel CSR employee perceptions can affect organizational identification by indirect on organizational commitment, relationship between the three confirmed CSR activities have a positive impact on employee attitudes and behavior and the impact on the relation between the employee and the organization, and actively fulfill the hotel CSR activities will enhance employees' understanding of corporate culture and values, improve work efficiency, reduce the wastage rate thus, enhance the comprehensive competitive power of hotel enterprises.

Future studies are needed to further improve the hotel employees' perception of CSR measurement index system, to further improve the measurement index system is scientific and practical, to further explore the characteristics of tourism and hotel industry CSR; a modest increase in sample size, fixed point was chosen to study CSR practice good hotel, improve the measurement index system and model of Pu to further increase the adaptability, data reliability and persuasion; in addition to the organizational identification and organizational commitment as dependent variables of CSR and employees' attitude and behavior, also can consider employee loyalty, satisfaction into the scope of the study, enrich the research system.

REFERENCES

Jo H, Song M H, Tsang A. ,2015. Corporate social responsibility and stakeholder governance around the world [J]. *Global Finance Journal*.29:42-69.

- Mozes, M., Josman, Z., Yaniv, E., 2011. Corporate social responsibility organizational identification and motivation. *Soc. Responsibil. J.* 7 (2), 310–325.
- Kucukusta D, Mak A, Chan X.,2013. Corporate social responsibility practices in four and five-star hotels: perspectives from Hong Kong visitors.[J]. *International Journal of Hospitality Management.* 34(1):19-30.
- Lee S, Heo C Y. ,2009.Corporate social responsibility and customer satisfaction among US publicly traded hotels and restaurants[J]. *International Journal of Hospitality Management.*28(4):635-637.
- Theodoulidis B, Diaz D, Crotto F, et al.,2017.Exploring corporate social responsibility and financial performance through stakeholder theory in the tourism industries[J]. *Tourism Management.* 62:173-188.
- Rhou Y, Singal M, Koh Y.,2016. CSR and financial performance: The role of CSR awareness in the restaurant industry[J]. *International Journal of Hospitality Management.* 57:30-39.
- Lee S K, Singal M, Kang K H.,2013. The corporate social responsibility-financial performance link in the U.S. restaurant industry: do economic conditions matter?[J]. *International Journal of Hospitality Management.*32(1):2-10.
- Lee S K, Park S Y. , 2009.Do socially responsible activities help hotels and casinos achieve their financial goals?[J]. *International Journal of Hospitality Management.* 28(1):105-112.
- Ferraz F A D, Gallardo-Vázquez D. ,2016. Measurement tool to assess the relationship between corporate social responsibility, training practices and business performance[J]. *Journal of Cleaner Production.*129:659-672.
- Abaeian V, Yeoh K K, Khong K W. ,2014.An Exploration of CSR Initiatives Undertaken by Malaysian Hotels: Underlying Motivations from a Managerial Perspective ☆[J]. *Procedia – Social and Behavioral Sciences.* 144:423-432.
- Su L, Swanson S R.,2017. The effect of destination social responsibility on tourist environmentally responsible behavior: Compared analysis of first-time and repeat tourists[J]. *Tourism Management.* 60:308-321.
- Park E, Kim K J, Sang J K. ,2017.Corporate social responsibility as a determinant of consumer loyalty: An examination of ethical standard, satisfaction, and trust[J]. *Journal of Business Research.*76:8-13.
- Kucukusta D, Mak A, Chan X.,2013. Corporate social responsibility practices in four and five-Star hotels: perspectives from Hong Kong visitors.[J]. *International Journal of Hospitality Management.* 34(1):19-30.
- Lee E M, Park S Y, Rapert M I, et al.,2012. Does perceived consumer fit matter in corporate social responsibility issues? [J]. *Journal of Business Research.* 65(11):1558-1564.
- Fu H, Ye B H, Law R.,2014. You do well and I do well? The behavioral consequences of corporate social responsibility[J]. *International Journal of Hospitality Management.* 40:62-70.

Yongki L, Kim Y [Y S, Kyunghee L, et al.,2012. The impact of CSR on relationship quality and relationship outcomes: a perspective of service employees.[J]. *International Journal of Hospitality Management*.31(3):745-756.

Martínez P, Bosque I R D.,2013. CSR and customer loyalty: The roles of trust, customer identification with the company and satisfaction[J]. *International Journal of Hospitality Management*.35(December 2013):89-99.

Oppewal H, Sullivan P, Alexander A.,2006. Consumer perceptions of corporate social responsibility in town shopping centres and their influence on shopping evaluations[J]. *Journal of Retailing & Consumer Services*.13(4):261-274.

Berg, P., Kalleberg, A.L., Appelbaum, E., 2003. Balancing work and family: the role of high commitment environments. *Ind. Relat.: J. Econ. Soc.* 42 (2), 168–188.

Chan, K.W., Wyatt, T.A., 2007. Quality of work life: a study of employees in Shanghai, China. *Asia Pacific Bus. Rev.* 13 (4), 501–517.

Rupp, D.E., Ganapathi, J., Aguilera, R.V., Williams, C.A., 2006. Employee reactions to corporate social responsibility: an organizational justice framework. *J. Organ.Behav.* 27 (4), 537-543.

Ali, I., Rehman, K.U., Ali, S.I., Yousaf, J., Zia, M., 2010. Corporate social responsibility influences, employee commitment and organizational performance. *Afr. J. Bus.Manage.* 4(12), 2796–2801.

Carroll, A.B., 1979. A three-dimensional conceptual model of corporate performance.*Acad. Manage. Rev.* 4 (4), 497–505.

Sheldon O. ,1923.A professional creed for managers[A]//: Merrill H F.Classics in Management [M]. New York: American Management Association,11-18.

Bowen H. *Social Responsibility of the Businessman* [M]. New York: Harper & Row, 1953. 31.

Devinney.T. ,2009. Is the socially responsible corporation a myth? The good, the bad,and the ugly of corporate social responsibility.*The Academy of Management Perspectives*, 23(2)

Carroll, A.B., 1991. The pyramid of corporate social responsibility: toward the moral management of organizational stakeholders. *Business Horizons* 7 (8),39–48.

Henriques I, Sadorsky P. ,1999.The relationship between environmental commitment and managerial perceptions of stakeholder important [J]. *Academy of Management Journal*. 42(1): 87-99.

Basu K, Palazzo G.,2008. Corporate social responsibility: A process model of sense making [J]. *Academy of Management Review*. 33(1): 122-136

Kang,K.H, Lee, S., Huh, C., 2010. Impacts of positive and negative corporate social responsibility activities on company performance in the hospitality industry[J].*International Journal of Hospitality Management* 29 (1.), 72–82.

Wang, H., 2010. Corporate social performance and financial-based brand equity. *The Journal of Product and Brand Management* 19 (5), 335–345.

Lee, Y.K., Lee, K.H., Li, D.X., 2012. The impact of CSR on relationship quality and relationship outcomes: A perspective of service employees. *Int. J. Hospital, Manage* 31 (3), 745–756.

Kucukusta, D., Mak, A., Chan, X., 2013. Corporate social responsibility practices in four and five-star hotels: Perspectives from Hong Kong visitors. *Int. J. Hosp. Manage.* 34 (0), 19–30.

Yongki L, Kim Y [Y S, Kyunghee L, et al., 2012. The impact of CSR on relationship quality and relationship outcomes: a perspective of service employees.[J]. *International Journal of Hospitality Management.* 31(3):745-756.

Rhou Y, Singal M, Koh Y. ,2016. CSR and financial performance: The role of CSR awareness in the restaurant industry[J]. *International Journal of Hospitality Management.* 57:30-39.

Rodriguez F, Cruz Y. Relation between social- environmental responsibility and performance in hotel firms [J]. *International Journal of Hospitality Management,* 2007, 26(4): 824-839.

Tse E, Ng P, Ross K. ,2003. Banyan Tree Hotels & Resorts: Gauging Investors' views on Corporate Social Responsibility [R]. Hong Kong.

Gu, H., Ryan, C., 2011. Ethics and corporate social responsibility :an analysis of the views of Chinese hotel managers. *Int. J. Hosp. Manage.* 30 (4), 875–885.

Elkington J. *Cannibals with Forks: The Triple Bottom Line of 21st Century Business* [M]. Oxford: Capstone Publishing Ltd. ,1997. 30-52.

Turker, D., 2009a. How corporate social responsibility influences organizational commitment. *J. Business Ethics* 89 (2), 189–204.

Park S, Song S, Lee S. Corporate social responsibility and systematic risk of restaurant firms: The moderating role of geographical diversification[J]. *Tourism Management,* 2017, 59:610-620.

Peng, X., Wei, J., Li, Y., 2013. CSR practices of China's hotel companies: content analysis of CSR information of top 15 hotel groups. *Tour. Tribune* 28 (3), 52–61.

Tajfel, H., Turner, J.C., 1979. An integrative theory of intergroup conflict. In: Austin, W.G., Worchel, S. (Eds.), *The Social Psychology of Intergroup Relations*. Brooks-Cole, Monterey, CA.

Mael, F., Ashforth, B.E., 1992. Alumni and their alma mater: a partial test of the reformulated model of organizational identification. *J. Organ. Behav.* 13 (2), 103–123.

Grandey A A, Fisk G, Mattila A, et al., 2005. Is service with a smile enough? Authenticity of positive displays during service encounters[J]. *Organizational Behavior & Human Decision Processes.* 96(1): 38-55.

Luthans F, 2002. The need for and meaning of positive organizational behavior[J]. *Journal of Organizational Behavior.* 23(6):295-706.

Griffin M A, Neal A, Parker S K.,2007.A new model of work role performance: Positive behaviors in uncertain and interdependent contexts[J]. *Academy of Management Journal*.50(2): 327-347.

Mathieu, J.E., Zajac, D.M., 1990. A review and meta-analysis of the antecedents, correlates, and consequences of organizational commitment. *Psychol. Bull.* 108 (2),171–194.

Lu V N, Capezio A, Restubog S L D, et al.,2016. In pursuit of service excellence: Investigating the role of psychological contracts and organizational identification of frontline hotel employees[J]. *Tourism Management*. 56:8-19.

Pfeffer,J.,1998.The Human Equation[M].Boston:Harvard Business School Press.

Mowday,R.T.,Porter,L.W.,Dubin,R.,1974.Unit Performance, Situational Factors, and Employee Attitudes[J].*Organizational Behavior and Human Performance*.12(2):231-248

Meyer,J.P.,Allen,N.J.A.,1991.Three-Components Conceptualization of Organizational Commitment[J].*Human Resource Management Review*.1(1):61-89.

van Knippenberg, D.,Sleebos, E., 2006.Organizational identification versus organizational commitment: self-definition, social exchange, and job attitudes. *J. Organ.Behav.* 27 (5), 571–584.

O'Reilly,C.A.,Chatman,J.,1986.Organizational Commitment and Psychological Attachment: The Effects of Compliance, Identification,and Internationalization on Professional Behavior[J].*Journal of Applied Psychology*.71(3):492-499.

Mael, F., Ashforth, B.E., 1992. Alumni and their alma mater: a partial test of the reformulated model of organizational identification. *J. Organ. Behav.* 13 (2),103–123.

Meyer,J.P.,Allen,N.J.A.,1991.Three-Components Conceptualization of Organizational Commitment[J].*Human Resource Management Review*.1(1):61-89.

Barnett M.,2007.Shareholder Influence Capacity and the Variability of Financial returns to Corporate Social Responsibility [J].*Academy of Management Review*.32(3):794-816

KimH.,2010.Corporate Social Responsibility and Employee-Company Identification [J].*Journal of Business Ethics*.95(4):557-569

Gully M.Phillips.,2013.A Mediated Moderation Model of Recruiting Socially and Environmentally Responsible Job Applicants [J].*Personel Psychology*.39(1):1-39

Maignan, I., Ferrell, O.C., 2001. Corporate citizenship as a marketing instrument Concepts, evidence and research directions. *Eur. J. Marketing* 35 (3/4),457–484.

Brammer, S., Millington, A., Rayton, B., 2007. The contribution of corporate social responsibility to organizational commitment. *Int. J. Hum. Resour. Manage.* 18(10), 1701–1719.

Hofman, P.S., Newman, A., 2013. The impact of perceived corporate social responsibility on organizational commitment and the moderating role of collectivism and masculinity: evidence from China. *Int. J. Hum. Resour. Manage.*, 1–22.

L.M.Shore&5.J.Wayne.,1993Commitment and employee behavior:comparison of effective commitment and continuance commitment with Perceived organizational support[J].*Journal of Applied Psychology*. 78(5):774-780.

G.Allen,G.Lynn&W.Rodger.,2003.The Role of Perceived Organizational Support and Supportive Human Resource Practices in the Turnover Process [J].*Journal of Management*.29(1):99-118.

A.H.Wyne,K.Charles&L.P.Pamela.,2003.Perceived Organizational support at a Mediator of the Relationship between Politics Perceptions and work outcomes[J]. *Journal of Vocational Behavior*.(4):438 –456.

J.W.Bishop,D.K.Scott&M.G.Goldsby.,2005. A construct validity study of commitment and Perceived support variables: A multifunction approach across different team environments.

Nunnally, J.C., 1978. *Psychometric Theory*, 2nd ed. McGraw-Hill., New York, NY. Bagozzi, R.P, Yi, Y., 1988. On the evaluation of structural equation models. *Journal of Academy of Marketing Science* 16 (1), 74–94.

Churchill, G.A., 1979. Paradigm for developing better measures of marketing constructs.*Journalof Marketing Research* 16 (1), 64–73.

Fornell, C., Larcker, D.F., 1981. Evaluating structural equation models with unobservable variables and measurement error. *Journal of Marketing Research* 18(1), 39–50.

OVERWHELMING OR EXCITING: AN ACTION STUDY OF CONFERENCE ATTENDEE EXPERIENCE

JESSICA WIITALA

University of Central Florida, USA

JEEYEON HAHM

University of Central Florida, USA

DEBORAH BREITER-TERRY

University of Central Florida, USA

ABSTRACT

Event experiences incorporate a number of components that provide attendees value and memory of each experience. Engaging individuals while creating an entertaining, engaging and beautiful (while functional) space may be challenging for show organizers. This qualitative action research study sought to investigate attendees experiences at a large annual conference. Qualitative, structured face-to-face random intercept interviews were conducted in Spring 2016 and Spring 2017 on the exposition floor and comparatively analyzed year over year to determine the attendees' needs, service priorities, event experience, and feedback. The researchers employed criterion sampling where all participants had to meet the criteria. The interview data was transcribed and coded for themes specified by the attendees regarding their specific experiences at the conference. The data were analyzed using counting to identify word frequency queries. The word frequency queries indicated that the overall impression and initial feelings, wow factors, value of attending the event, and operational feedback for the organization and show managers. The purpose of this action research was twofold, to discover the experiences of conference attendees during and immediately following the consumption of these experiences. Based on the continuous feedback received by the attendees, a systematic approach to problem-solving revealed a second purpose of the study, describing the organization's reconsideration, solutions, recovery and change. The results allowed the organization under study with opportunities for improving attendee experience year over year. While the current study conducted focused on a single event, implications should be drawn to corporate events across the country.

Keywords: event experience, operations, attendee feedback, action research strategy

INTRODUCTION

Investigation into the topics of meetings, incentives, conventions, and events (MICE) industry has increased over the past years with the growth of the event industry in practice, academia, and research. This growth has highlighted various aspects of event management including: site selection, marketing, planning, etc. (Park & Park, 2017). There are various aspects of event experience according to Kaplanidou and Vogt (2010) which incorporate: organizational, environmental, physical, emotional, and social aspects (or components). Event organizers must consider numerous factors during the planning process, such as venue and destination selection, facility-related characteristics, safety and security, communications, program development, and budget.

Creating an event space that is both functional and memorable involves more than simply selecting a venue and creating an entertaining and beautiful space (Nelson, 2009). A key objective within the service industry is delivering experiences that engage individuals (Hwang & Seo, 2016; Pine & Gilmore, 1998, 1999). The hallmark of an event is the value and memory of the experience of the attendees (Warnaars, 2009). Therefore, it is imperative to understand the factors that contribute to a memorable experience.

This qualitative action research study focused on the event experience of the attendees at an annual conference hosted by a multinational corporation at a major convention center in the United States. Qualitative structured face-to-face intercept interviews were conducted to explore attendees' feedback and perceptions. Content analysis was used to analyze the data that were collected in Spring 2016 and Spring 2017 on the exposition floor and comparatively analyzed year over year to determine the attendees' needs, service priorities, event experience, and feedback.

LITERATURE

The antecedents of satisfaction have long been investigated within consumer research (Anderson & Sullivan, 1993). Customer satisfaction provides the foundation for hospitality and service experiences, which has been a key objective in the contemporary hospitality and tourism industry. The quality of the service and expectations of guests and attendees will ultimately impact their satisfaction. Schmitt (1999, 2003) expresses that managing a customer's entire experience is the foundation of customer experience management (CEM).

Customer Experience

The experience of attendees is of growing importance as hospitality and tourism enters a new era of the experience economy. Pine and Gilmore (1999) define customer experience as "events that engage individuals in a personal way (p. 12)". While customer experience is of growing importance in practice and research, there is no consensus that has been developed in regards to what constitutes a good experience (Hwang & Seo, 2016).

In the event industry Getz (2007) expresses that events intend to create individual and collective experiences of those that attend. The nature of experience in research within the context of the event industry has been limited. According to Berridge (2012a, b), it has been developed from theories in marketing. Likewise, research conducted with regards to event experience has focused primarily on social events such as fairs, festivals, and sporting events (Geus, Richards, & Toepoel, 2016; Kaplanidou & Vogt, 2010; Morgan, 2008). Regardless of the market segment, modern event management aims to deliver experiences. This challenges event organizers to design and produce a "wow factor" that will be memorable, special, and unique (Beard & Russ, 2017).

METHODOLOGY

A qualitative action research strategy was employed to achieve the research objectives for this study. Action research, according to Altinay, Paraskevas and Jang (2016) "is a strategy in which the researcher joins the organization under study for a period of time and, with the findings of his or her study, helps the organization to solve the problems it is facing (p. 101)". Prior convention and meeting industry literature conducted with regard to the various aspects of management and planning have been investigated primarily from the meeting planner's perspective. On the contrary, this study sought to analyze the attendee experience.

Qualitative, structured face-to-face random intercept interviews were conducted in 2016 and 2017 on each of the three conference days for an annual conference that was held at a major convention center located in the southeast of the United States. The researchers employed criterion sampling where all participants had to meet the criteria. All participants were officially registered with the conference and were general attendees (exhibitors, speakers, the organization's employees and any attendee accompanied by an organization employee were exempt).

Following Creswell (2013), the analysis of the data starts inductively from specific to more general perspectives to develop themes. Then, evidence is gathered deductively to support the developed themes and interpretations (Creswell, 2013). Breiter and Milman (2005) identified categories for reasons to attend a specific show, which were utilized as a guide for a semi-deductive analysis approach. The interview data was transcribed and coded for themes specified by the attendees regarding their specific experiences at the conference. Content analysis was utilized to summarize the inferences, discover patterns, and compare the findings to support the conclusions found in other research. This process allows the researcher to reach value inferences by preserving some of the meanings of the data (Krippendorff, 2013).

FINDINGS

A team of researchers conducted a total of 114 interviews in 2016 and 184 interviews in 2017. The majority of attendees interviewed for both years were between the ages of 30 and 50 and almost an even distribution of males and females.

The data were analyzed using counting to identify word frequency queries. Counting was deemed appropriate to reduce the data based on the large volume of text. According to Krippendorff (2013) counting was deemed as a justifiable analytical technique in this case as the resulting frequencies could be related to and had context and meaning in the specific context of the research being conducted. The frequencies were analyzed based on the overall impression of the event, value of the event, specific wow factors, educational factors (including interactive or engaging content), and organizational feedback (i.e., operationally).

The word frequency queries indicated that the overall impression and initial feelings, such as "overwhelming" and "exciting", were evident on the first two days rather than the content and purpose of the conference. Based on the feedback from 2016, the show managers modified the event design and program and in 2017 the feedback from day one shifted from "overwhelming" as the most frequent count to "big," "networking," and "informative."

The third and final conference day in 2016 indicated more content specific themes like "informative" and "fun". In 2017 however networking was frequently mentioned on each of the three conference days but it was most dominant on day three, along with "informative" and "big."

The data reflected that attendees do not recognize a single wow factor and that overall, the entire set-up of the event design wows both first time attendees and veterans of the conference. The most common wow factors on the first day of the conference in both 2016 and 2017 included the venue, layout of the show floor, the agenda, and the keynote speakers. Day three wow factors differed significantly and shifted to the content of the conference rather than the design and layout of the show floor.

Figure 1
2016 DAY 1 WORD CLOUD



Figure 2
2017 DAY 1 WORD CLOUD



Attendee feedback regarding the value of attending the event and their comments for operational improvement aligned with the themes identified by Breiter and Milman’s (2005) reasons to attend a specific show. The most valuable aspects included networking, education, and interaction. Networking was identified in the word clouds for each day in 2016 and 2017 however was more dominant in 2017. Networking was the most important reason identified by 61.1% of cases by Breiter and Milman (2005). This was followed by education in Breiter and Milman (2005) who identified 47.1% of attendees reasons to attend a specific show was to learn about new products and 24.1% was to receive continuing education credits

Operationally, attendees’ specific feedback for the organization included both comments for improvement and satisfaction with elements that were implemented well. In 2016, the most frequent comments for improvement included the keynote; specifically, the timing of the keynote and subsequent impact that it had on sessions, the keynote theater design, size, and sound. This was improved upon greatly in 2017. The show managers designed a new theater layout that was open and more inclusive. Attendees took notice to this redesign stating that “The open keynote stage was nice last year but it was closed off so you didn't feel welcome, this year you can feel the vibe.”

In 2016, the analysis of attendee feedback also indicated that additional signage for the restrooms and dining would be beneficial as attendees expressed that these areas were “not

interviewed on day two commented on the seating possibilities and additional charging stations, explaining that they “would like to have more places to sit so I can do my work.” Day two of the conference in 2017 identified another, even more problematic issue due in part to the open layout; attendees were complaining of noise on account of the amplified speakers across the show floor. While the organization received commendations for the open layout expressing that “the most impressive were the open layout, the good atmosphere and the ease to locate sessions because of the open layout,” this presented an issue as the open theaters and sessions made it difficult for attendees to “focus or hear anything.”

While attendees expressed that they enjoyed the event app in 2016, more live information and details about the session content was desired. The attendees also enjoyed the convenience of multiple registration areas, including at the airport. Lastly, food was not found to be an issue or complaint however in 2016 many attendees compared the food to another, similar industry conference hosted in another competing city in the United States and regarded the food as being of better quality there. This was not an issue in 2017 and the organization found that “catering is not an issue at all.” Overall, the level of importance associated with satisfaction and conference experiences warrants further investigation in the corporate market segment.

CONCLUSIONS

This action research study attempted to identify attendee’s event experience at an annual conference hosted by a multinational corporation at a major convention center. The purpose of this action research was twofold, to discover the experiences of conference attendees during and immediately following the consumption of these experiences. Based on the continuous feedback received by the attendees, a systematic approach to problem-solving revealed a second purpose of the study, describing the organization’s reconsideration, solutions, recovery and change. Analyzing attendee experience at a large annual conference has identified how the organization under study may improve attendee experience and assess the opportunities for improvement year over year.

The themes identified in the data aligned with current event literature. The overall impression of the event, value of the event, wow factors, educational factors, and organizational feedback encompass the needs and service priorities of conference attendees. Creating a memorable experience should start with the priorities of attendee’s needs and wants. The continuous improvement and added value should lead to improved experiences for attendees.

The attendee feedback that was analyzed in this study was able to help the organization and show managers determine short and long term changes to implement in order to better improve attendee experience. While the current study conducted focused on a single event, implications should be drawn to corporate events across the country.

REFERENCES

- Altinay, L., Paraskevas, A., & Jang, S. S. (2016). *Planning research in hospitality and tourism*. (2 Ed.). New York, NY: Routledge.
- Anderson, E. W., & Sullivan, M. W. (1993). The antecedents and consequences of customer satisfaction for firms. *Marketing Science*, 12(2), 125-143.
- Beard, C., & Russ, W. (2017). Event evaluation and design: Human experience mapping. *Event Management*, 21(3), 365-374.

Berridge, G. (2012a). Designing event experiences. *The Routledge Handbook of Events*. Oxford, UK: Routledge.

Berridge, G. (2012b). Event experience: A case study of differences between the way in which organizers plan an event experience and the way in which guests receive the experience. *Journal of Park and Recreation Administration*, 30(3), 7-23.

Breiter, D., & Milman, A. (2006). Attendees' needs and service priorities in a large convention center: Application of the importance–performance theory. *Tourism Management*, 27(6), 1364-1370.

Creswell, J. W. (2013). *Qualitative inquiry & research design: Choosing among five approaches*. (3 Ed.). Thousand Oaks, CA: Sage.

Getz, D. (2007). Event tourism: Definition, evolution, and research. *Tourism Management*, 29(3), 403-428.

Geus, S. D., Richards, G., & Toepoel, V. (2016). Conceptualisation and operationalisation of event and festival experiences: creation of an event experience scale. *Scandinavian Journal of Hospitality and Tourism*, 16(3), 274-296.

Hwang, J. & Seo, S. (2016). A critical review of research on customer experience management: Theoretical, methodological and cultural perspectives. *International Journal of Contemporary Hospitality Management*, 28(10), 2218-2246.

Kaplanidou, K., & Vogt, C. (2010). The meaning and measurement of a sport event experience among active sport tourists. *Journal of Sport Management*, 24(5), 544-566.



UCF

**Rosen College of
Hospitality Management**

UNIVERSITY OF CENTRAL FLORIDA