

ATWATER KENT RADIO

SERVICE MANUAL

JUNE, 1931

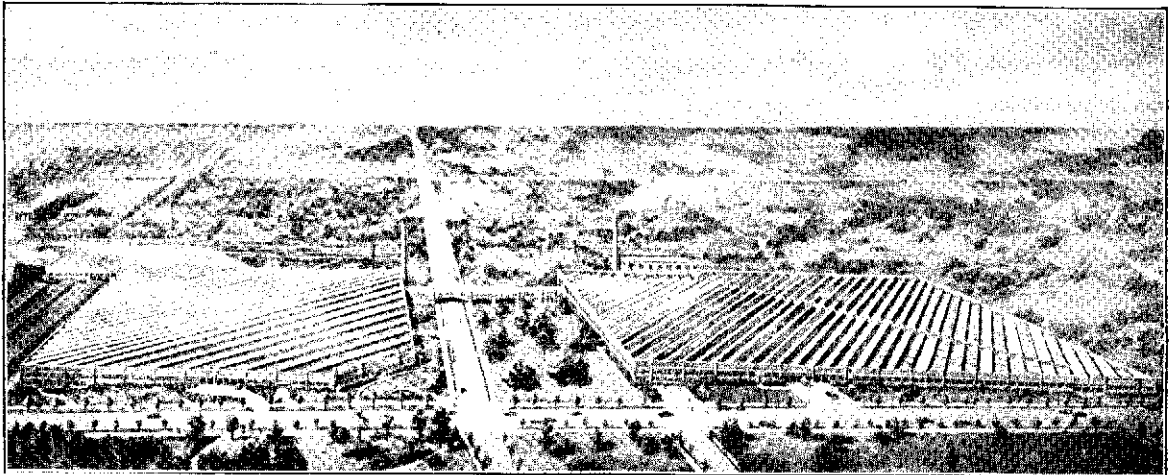

THE FACTORY BEHIND THE PRODUCT

*This Supplement, Pages 1 to 120
Supersedes Pages 1 to 146, Previously Issued*

ATWATER KENT MANUFACTURING COMPANY

1700 WISSAHICKON AVENUE, PHILADELPHIA, PA.

Printed in U. S. A. Copyright June 1931, by Atwater Kent Mfg. Co.

INTRODUCTION

1. Purpose of Service Manual

The object of the Service Manual is to assist the retailer of Atwater Kent radio products in giving prompt and efficient service to the consumer-owner. Since in accordance with our Radio Service Policy, service on Atwater Kent radio products is to be handled by Atwater Kent dealers and distributors only, this publication should be considered confidential and except in special cases, is furnished only to regularly appointed outlets of Atwater Kent radio merchandise.

2. Importance of Service

Service has "come into its own" during the past few years and its importance is continually becoming more widely recognized. The value of prompt and courteous service by the dealer cannot be over-emphasized. Service is closely linked with sales—in fact the one depends on the other. The radio dealer who has foresight will build for the future by maintaining a neat and efficient repair department and employing a competent service personnel consistent with the size of his organization. There is no better step toward building good-will for Atwater Kent products in his immediate locality.

3. Dealer Service Procedure

The dealer who has a reasonably well equipped service shop will find that he is in a position to handle the servicing of practically any set which comes to him for repair, since the bulk of repairs will not be of a difficult nature.

In the event that he is unable to perform a certain repair, the set or unit should be returned to his local distributor, who maintains a complete service department similar to that of the factory. The distributor will furnish his dealers with complete instructions for return of material, such as making out of return report blanks and other routine in connection with the handling of service matters.

4. Dealer's Parts Stock

We strongly urge that every dealer carry in stock a supply of such repair parts as may be most commonly required for the more popular types of Atwater Kent sets and speakers. This will eliminate the possibility of a dissatisfied customer, resulting from the delay necessarily involved in ordering a part from the distributor.

Newly appointed dealers should consult their distributor regarding a suitable initial stock to be carried.

Repair parts must be purchased from the distributor. No parts are sold direct from factory to dealer.

5. Repair Charges—Warranty Repairs

The charge on a repair job for the consumer, on a set beyond the warranty, may be based on the consumer price of the repair parts used, plus a charge for

the time required, at a definite rate per hour. The time charge will cover the time consumed in testing the set when repaired, and in calling for and delivering the set, if this is done.

Our factory warranty on new products, involves the replacement of parts defective in workmanship or material, and covers a period of 90 days from date of sale to the consumer.

6. Service Policy

A complete printed "Service Policy," definitely outlining the factory's plan on service matters, is sent once a year to our distributors, and such information from this as is required by the dealer will be passed on to him by the distributor. A definite understanding between dealer and distributor on all matters pertaining to service will be the means of preventing much conflict and controversy. It cannot be too strongly urged that all instructions from the distributor be carefully followed, so that complete co-operation will exist. Written instructions, such as bulletins, etc., should be kept handy in a loose-leaf note book.

7. Service Literature

The dealer will do well to keep readily available, **ALL** literature pertaining to service which comes into his place of business.

There are several excellent monthly radio trade publications which are invaluable to the retail dealer, both from a sales and service standpoint. We believe the small price of annual subscription to several of these magazines will be more than repaid by the excellent information and ideas they contain.

Two or three good text books on radio will also not be out of place on the dealer's book shelf. An easily understandable book on the theory of radio and a practical book on general radio service and repairing are suggested.

8. Factory Service Course

One of the best ways in which the recognized Atwater Kent dealer (or his service man) can familiarize himself more completely with the correct methods of servicing Atwater Kent radio products, is to spend a week or two in our factory Service Department. We have mapped out a course of training to be followed in this work, which completely covers the various steps in repairing, assembling, and testing all models of our sets, speakers, and power units.

The service course takes from one to three weeks depending on the ability of the individual. There is no charge for the instructions, but the dealer will naturally furnish the transportation and living expenses connected with this visit to Philadelphia. A letter of introduction from the local distributor is required and must be presented at the factory for identification purposes.

THEORY SECTION

Knowledge of Theory Is Essential

While the primary purpose of the Service Manual is to give the dealer information about testing and repairing Atwater Kent receiving sets, we believe that an understanding of the fundamental principles of radio and a knowledge of how our sets function will enable him to perform this work more intelligently. It is, of course, essential to know what to do to correct troubles, but a knowledge of the theory and functioning of the various units of the set will enable the repairman to locate the trouble more readily. If an unusual condition arises in a set, a repairman without a knowledge of the principles involved, can correct the trouble by "hit-or-miss" methods only. The service man who has this fundamental knowledge can analyze the condition and then determine the remedy.

The Theory Section

The theory section of this manual is not a complete course but it is intended for study in conjunction with a good radio text book.

Studying Radio

It requires continual study, observation, and actual experimenting to acquire a real understanding of radio. Experimenting will drive home facts that might otherwise be difficult to learn.

There are a few text books that give an outline for a course of radio experiments which require only simple and inexpensive equipment. For one who wants to learn radio, there is no better way to do it than to follow such an experimental course and supplement it with diligent study of a good radio text book.

Elements In Radio Receiver

In addition to tubes and speakers, there are only four general types of parts in a radio receiver: Condensers, transformers, chokes, and resistors.

In order to know how a receiver functions, it is necessary to understand the action of these parts on various types of current. A table covering this subject is given below, and more detailed information is given throughout the theory section.

ACTION OF RADIO PARTS ON VARIOUS TYPES OF CURRENT

Name of Part	Action of Part on Current of:			
	D. C.	A. C.		
		R. F.	I. F.	A. F.
Small Condensers, such as phone condensers, grid condensers, R. F. by-passes, etc.	Do not Pass	Pass	Pass	Do not Pass
Large Condensers, such as filter condensers, A. F. by-passes, etc.	Do not Pass	Pass	Pass	Pass
Resistors.	Oppose	Oppose**	Oppose	Oppose
R. F. Chokes or primaries of R. F. transformers.	Pass	Oppose	Pass	Pass
I. F. Chokes or primaries of I. F. transformers.	Pass	Pass*	Oppose	Pass
A. F. Chokes or primaries of A. F. transformers.	Pass	Pass*	Pass*	Oppose
Secondary of A. F. Transformers.	Pass	Pass*	Pass*	Oppose
Parallel Tuned R. F. Circuit. (Condenser and coil.)	Passes	Opposes R. F. of frequency to which it is resonant. Passes other R. F. frequencies.	Passes	Passes
Series Tuned R. F. Circuit. (Condenser and coil.)	Does not Pass	Passes R. F. of frequency to which it is resonant. Opposes other frequencies.	Opposes	Opposes
Parallel Tuned I. F. Circuit. (Condenser and coil.)	Passes	Passes	Opposes I. F. of frequency to which it is resonant. Passes other I. F. frequencies.	Passes
Series Tuned I. F. Circuit. (Condenser and coil.)	Does not Pass	Does not Pass	Passes I. F. of frequency to which it is resonant. Opposes other I. F. frequencies.	Does not Pass

* This is true only if the I. F. or A. F. choke has a rather large distributed capacity. If the distributed capacity is small, an R. F. by-pass condenser is connected across the choke when necessary.

** In circuits carrying R. F. current, the effective value of a resistor will be reduced by the capacitance across the resistor terminals and its connecting leads, etc.

CONDENSERS

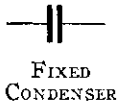

FIXED CONDENSER



FIXED CONDENSERS IN SERIES

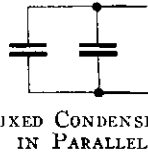

FIXED CONDENSERS IN PARALLEL

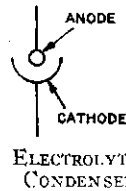

ELECTROLYTIC CONDENSER



VARIABLE CONDENSER

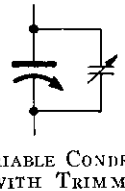

VARIABLE CONDENSER WITH TRIMMER

When condensers are connected in parallel, the total capacitance is equal to the sum of the values of all the condensers. When connected in series, the total capacitance is equal to the reciprocal

of the sum of the reciprocals or $\frac{1}{\frac{1}{C_1} + \frac{1}{C_2}}$

The capacitance of a variable condenser is greatest when the plates are meshed and lowest when the plates are not meshed.

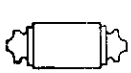

PHONE OR GRID CONDENSER



PHONE OR STOPPING CONDENSER

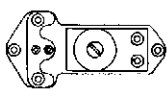

TRIMMER CONDENSER

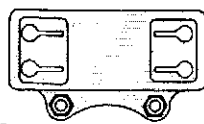

BY-PASS CONDENSER

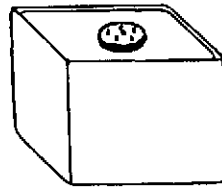

FILTER CONDENSER ASSEMBLY FOR POWER UNIT

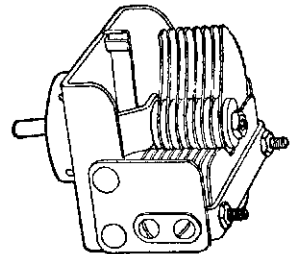

VARIABLE CONDENSER AIR DIELECTRIC

The movable plates comprise the rotor, and the stationary plates comprise the stator.

MICA DIELECTRIC (INSULATION BETWEEN PLATES)

TINFOIL PLATES AND PAPER DIELECTRIC

CHOKES



R. F. CHOKER COIL OFFERS A HIGH EFFECTIVE RESISTANCE OR IMPEDANCE TO R. F. CURRENT



A. F. CHOKER COILS OFFER A HIGH EFFECTIVE RESISTANCE OR IMPEDANCE TO A. F. CURRENT

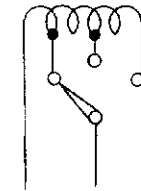
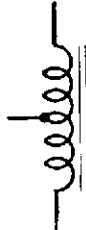

TAPPED R. F. INDUCTANCE

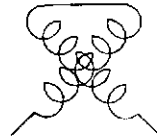

VARIOMETER OR CONTINUOUSLY VARIABLE INDUCTANCE

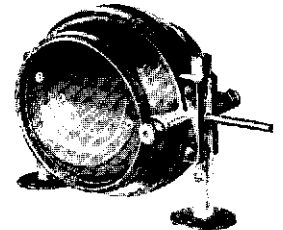

VARIOMETER The movable coil is the rotor, and the stationary coil is the stator.

TRANSFORMERS

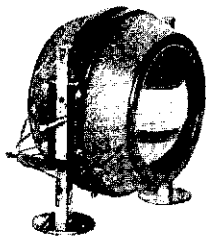
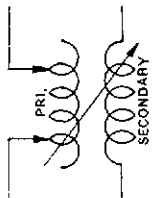

R. F. VARIO-COUPLER OR TRANSFORMER WITH TAPPED PRIMARY

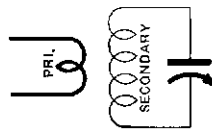

TUNED R. F. TRANSFORMER WITH VARIABLE CONDENSER

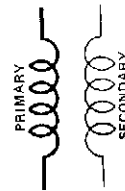
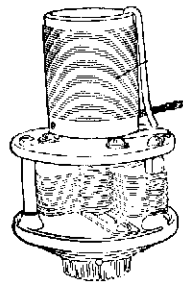

R. F. TRANSFORMER

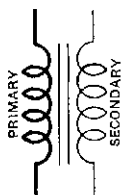
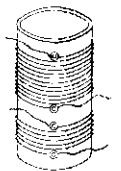

AUDIO-FREQUENCY TRANSFORMER

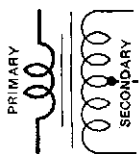

INPUT A. F. TRANSFORMER

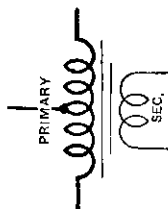

OUTPUT A. F. TRANSFORMER

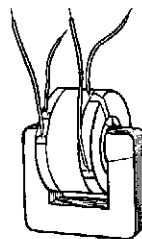

AUDIO-FREQUENCY TRANSFORMER

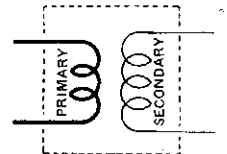

SHIELDED R. F. TRANSFORMER

SPEAKERS



HEAD PHONES

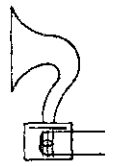

HORN SPEAKER

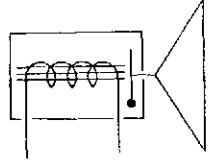

CONE SPEAKER

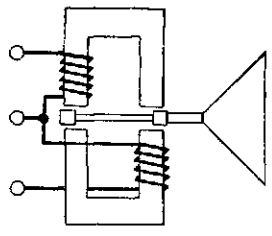

INDUCTOR-TYPE SPEAKER

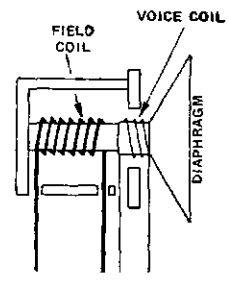

ELECTRO-DYNAMIC SPEAKER WITH ELECTRO-MAGNET

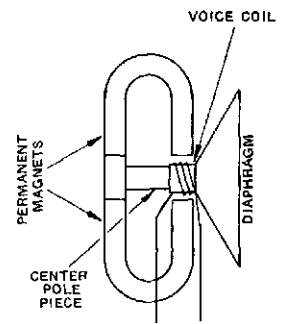

(147) ELECTRO-DYNAMIC SPEAKER WITH PERMANENT MAGNET

SWITCHES

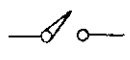

SINGLE-POLE SINGLE-THROW (S.P.-S.T.)

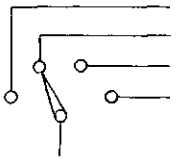

FOUR-POINT TAP SWITCH



SINGLE-POLE SINGLE-THROW (S.P.-S.T.)



THREE-POLE SINGLE-THROW (T.P.-S.T.)

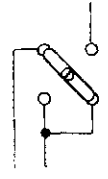

SINGLE-POLE DOUBLE-THROW (S.P.-D.T.)

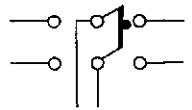
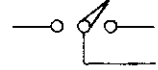

DOUBLE-POLE DOUBLE-THROW (D.P.-D.T.)



TOGGLE SWITCH

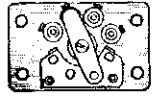

FOUR-POINT TAP SWITCH

SINGLE-POLE DOUBLE-THROW (S.P.-D.T.)



DOUBLE-POLE DOUBLE-THROW SWITCH (D.P.-D.T.)

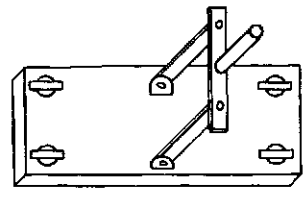

MISCELLANEOUS



ANTENNA OR AERIAL (Inside or Outside Types)



GROUND OR EARTH



CHASSIS CONNECTION (Connection to metal frame of set)

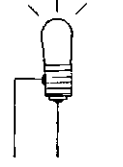

DIAL LIGHT to illuminate dial, or PILOT LIGHT to indicate when current is on or off

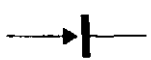

CRYSTAL DETECTOR



CURRENT OR VOLTAGE METER

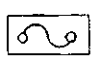

FUSE, used to prevent damage that might result from overload



WIRES CROSSED, NO CONNECTION



WIRES CONNECTED

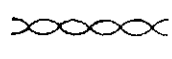

TWISTED PAIR



SHIELDED LEAD

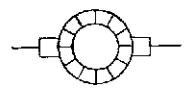

DIRECT CURRENT MOTOR OR GENERATOR



A. C. MOTOR OR GENERATOR



SINE WAVE, symbol for alternating current or cycles

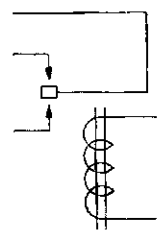

RELAY. A relay may be regarded as an electrically-operated switch. There are numerous varieties.

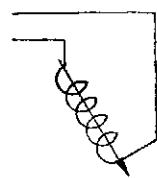

PHONOGRAPH PICK-UP. The pick-up generates a weak current corresponding to the image of the sound waves cut in the grooves on a phonograph record.



BATTERY, storage or dry types.

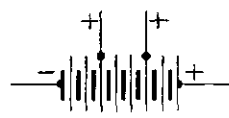

BATTERY IN SERIES. The total voltage equals the sum of the voltages of all the cells.

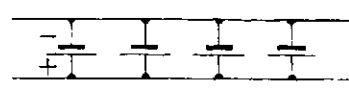

BATTERIES IN PARALLEL. The total voltage is the voltage of one branch.

RESISTANCE AND VOLTAGE DROP

When analyzing trouble in a radio set, it is very helpful to have a clear idea of the relations between current, voltage and resistance in D. C. circuits. We therefore recommend close study of the diagrams and rules on this and the following page.

Voltage (electro-motive force or e. m. f.) is the pressure in an electrical circuit. The unit of pressure is the *volt*.

Current is rate of flow of electricity through the circuit. The unit of current is the *ampere*.

Resistance is the opposition a circuit offers to the flow of current. The unit of resistance is the *ohm*.

The relations between these units are given on the next page.

If we apply the rule regarding current to the three lower circuits shown in Figure 3, we find that in each case the current is two amperes (100 volts divided by 50 ohms equals 2 amperes). An example of parallel resistance is shown in Figure 3-A.

In a series circuit, the voltage across one part may be easily determined if we know the total resistance and the voltage in the circuit: First find the percentage that the resistance of the particular part has to the total resistance. The voltage across that part is that same percentage of the total voltage. Thus assume that in the bottom circuit of Figure 3, we want to know the voltage across the 5 ohm resistor. We know the total resistance is 50 ohms. Five ohms is 10% of the total resistance. In turn, 10% of the total voltage is 10 volts, which is the voltage across the 5-ohm resistor.

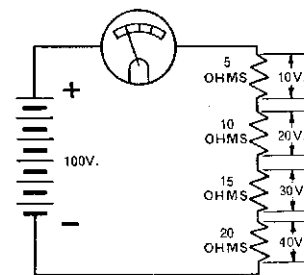
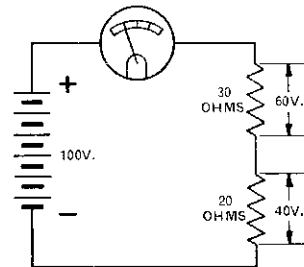
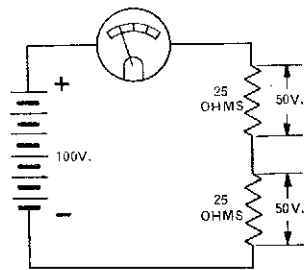
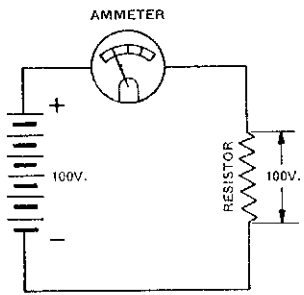
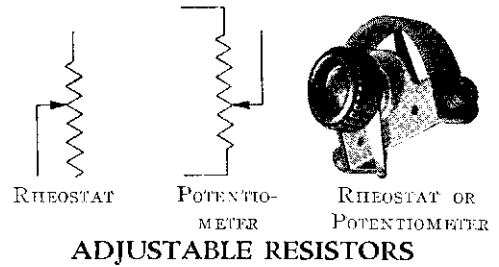
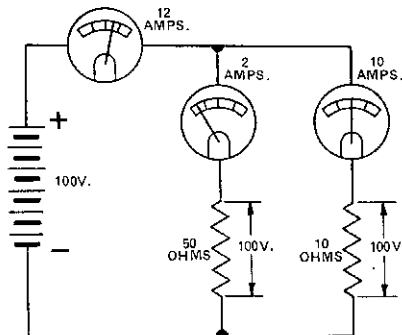
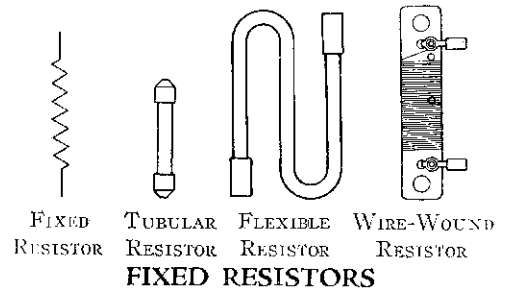

FIG. 3 (Above.) In a Series Circuit, the Voltage Across One Resistor is to the Total Voltage as the Value of that Resistor is to the Total Resistance. This is explained in the text.



ADJUSTABLE RESISTORS



FIXED RESISTORS

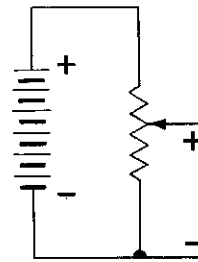

POTENTIOMETER. The potentiometer or voltage divider is usually a resistor with an adjustable contact connected as shown at the left. It is used to secure any intermediate voltage from zero to maximum from a given source. In the circuit, when the slider is at the bottom of the resistor, the output voltage is zero. When the slider is at the top of the resistor, the output voltage is maximum. The potentiometer may be used in D. C., A. F., I. F., or R. F. circuits.

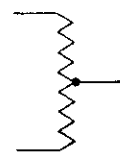

FILAMENT-SHUNT RESISTOR with centre tap. This is connected across A. C.-operated filaments and the grid-return leads of the tubes are connected to the centre tap. The purpose of the resistor is to minimize hum.

FIG. 3-A. RESISTORS IN PARALLEL. When resistors are connected in parallel across a known voltage, the current through each resistor may be calculated separately ($I = \frac{E}{R}$). The total current equals the sum of the currents through the various resistors.

Resistance and Voltage Drop (Continued)

VOLTS = AMPERES \times OHMS
($E = I \times R$)

AMPERES = VOLTS \div OHMS
($I = V \div R$)

OHMS = VOLTS \div AMPERES
($R = V \div I$)

POWER (WATTS) = VOLTS \times AMPERES
($W = V \times A$)

OR

POWER (WATTS) = AMPERES SQUARED \times OHMS
($W = I \times I \times R$)

Total value of resistances in series = $R_1 + R_2 + R_3$, etc.

Total value of resistances in parallel = $\frac{1}{\frac{1}{R_1} + \frac{1}{R_2} + \frac{1}{R_3}}$, etc.

R_1, R_2, R_3 , etc., are the values of the separate resistors.

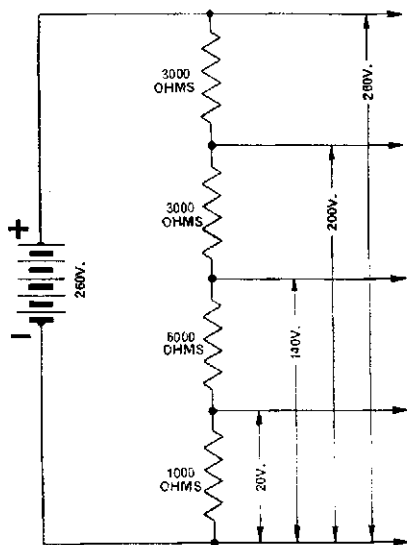

FIG. 4. VOLTAGE DISTRIBUTION ACROSS A SERIES OF RESISTORS.

The 1,000-ohm resistor is 1/13 of the total circuit resistance, so the voltage across it is 1/13 of the total voltage, or 20 volts. The first two resistors, totaling 7,000 ohms, represent 7/13 of the total resistance, so the voltage across them is 7/13 of 260, or 140 volts.

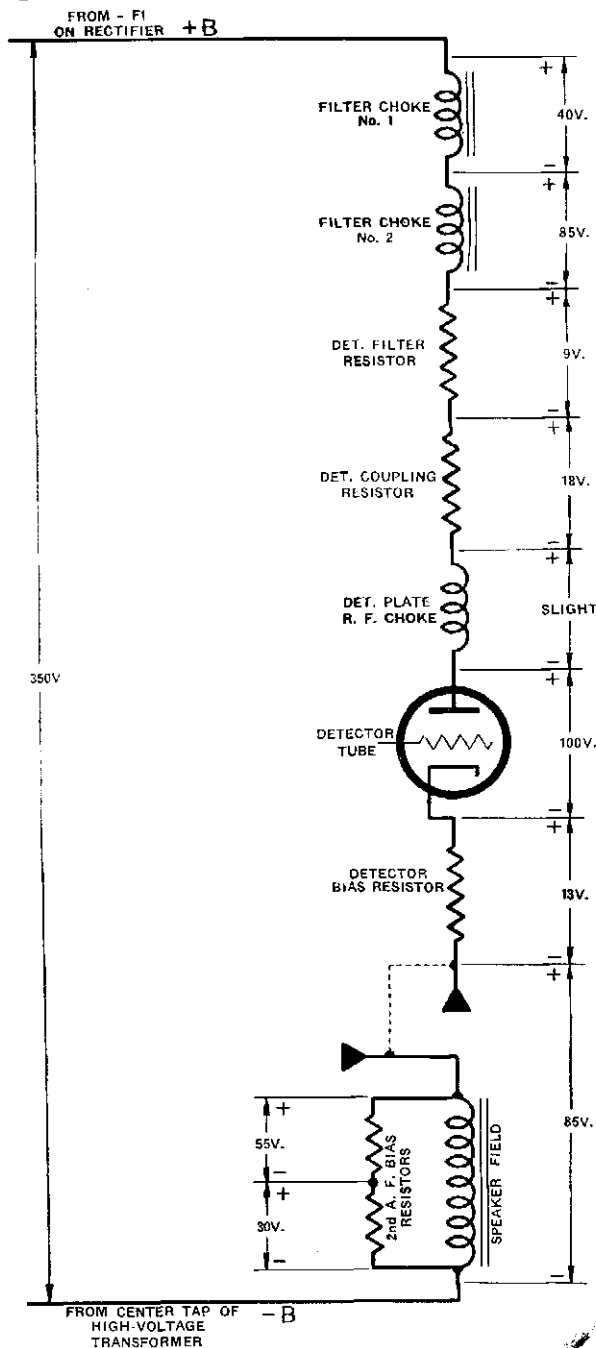

FIG. 4-A. VOLTAGE DISTRIBUTION IN DETECTOR PLATE CIRCUIT OF MODEL 55.

When making voltage measurements and diagnosing trouble in case of incorrect voltage, it is extremely helpful to have a clear idea of voltage drop across resistors in a series circuit. Practically all radio trouble shooting consists of simple D. C. voltage measurements.

It is important to remember that when measuring across an open resistor in a series circuit, the voltmeter completes the circuit and if the normal value of the resistor and the resistance of the meter are somewhat alike, the voltage reading may be very nearly correct.

Also it is important to remember that the voltmeter resistance will affect the resistance of the circuit and in general will make the measured voltage lower than the normal operating voltage. Thus, if the 50-volt scale of a 1,000-ohm-per-volt meter (in which case the meter resistance is 50,000 ohms) is used to measure the voltage across a 50,000-ohm resistor in a series circuit containing other resistors, the effective resistance is reduced to 25,000 ohms and the measured voltage will be correspondingly lower than the actual voltage.

INDUCTANCE, CAPACITANCE, REACTANCE AND IMPEDANCE

Inductance

A coil of wire is an **inductor** and it provides a property termed **inductance**. The inductance depends, among other things, on the number of turns of wire, the size of the coil, and whether the core is magnetic or non-magnetic.

A small number of turns provide a small inductance. A large number of turns provide a large inductance. A magnetic core increases the inductance.

The unit of inductance is the **henry**.

The total *inductance* of inductors connected in series or in parallel (without any couplings between them and negligible resistance) is calculated the same as for resistors (see Page 7).

Capacitance

Two conducting plates separated by an insulator comprises a **condenser**. A condenser provides a property termed **capacitance**. The capacitance depends, among other things, on the area of the plates, the distance between the plates, and the nature of the insulation (**dielectric**) between the plates.

The capacitance may be increased by increasing the area of the plates or by decreasing the distance between them. For a given distance between the plates, a paper or mica dielectric gives a higher capacitance than air.

The unit of capacitance is the **farad**. In radio work the unit commonly used is the **micro-farad** (mfd.) which is one-millionth of a farad.

The total *capacitance* of condensers connected in **series** equals $C1 \div C2$, etc. Thus if two .0005 micro-farad (mfd.)

condensers are connected in series, the total capacitance is .00025 mfd.

The total *capacitance* of condensers connected in **parallel** equals $C1 + C2$, etc. Thus if two .0005 mfd. condensers are connected in parallel, the total capacitance is .001 mfd.

Reactance

The **opposition** offered by a condenser or inductor to the flow of an alternating current is termed the **reactance**. In a condenser, it is capacitive reactance. In an inductor, it is inductive reactance.

The *reactance* of a **condenser** decreases as the frequency of the applied voltage increases.

$$\text{The capacitive reactance in ohms.} = \frac{1}{6.28 \times \text{frequency in cycles/sec.} \times \text{capacitance in farads.}}$$

The *reactance* of an **inductor** increases as the frequency of the applied voltage increases.

$$\text{The inductive reactance in ohms.} = 6.28 \times \text{frequency in cycles/sec.} \times \text{inductance in henries.}$$

The total *reactance* of inductors in parallel or series, or the *reactance* of condensers in parallel or series, is calculated in the same way as for resistors (see Page 7).

Impedance

Impedance is the **effective resistance** or **opposition** that a circuit or part offers to the flow of alternating current. Impedance is calculated from the resistance and reactance of the circuit or part.

ELECTRO-MAGNETIC FREQUENCY SPECTRUM

Name	Approximate Wave Length	Approximate Frequency in Kilocycles Per Second	Approximate Number of 10-Kilocycle "Channels" in Each Range
"Cosmic" Rays, X-Rays and Invisible Ultra-Violet Waves.	Extremely Short	Extremely High	
Visible Waves.	From Violet 0.000039 cm. To Red 0.000077 cm.	769,000,000,000 389,600,000,000	37,940,000,000
Infra-red and Heat Waves.	From 0.000077 cm. To 0.006 cm.	389,600,000,000 5,000,000,000	38,460,000,000
Long Heat Waves.	About 0.006 cm.	5,000,000,000	
Shortest Radio Wave Commonly Used.	5 Meters (500 cms.)	60,000	499,994,000
Short Radio Waves.	From 5 meters To 200 meters	60,000 1,500	5,850
Broadcast Radio Waves.	From 200 meters To 545 meters	1,500 550	95
Long Radio Waves	From 545 meters To 2,500 meters	550 120	43
Ship-Shore Stations, etc.	From 2,500 meters To 30,000 meters	120 10	11
High-Powered International Stations, etc.	From 30,000 meters To 18,750,000 meters	10 (10,000 cycles) .016 (16 cycles)	1
Audio Frequencies			

AUDIO-FREQUENCY RANGE OF A FEW MUSICAL INSTRUMENTS

Name	Approximate Range
String Instruments	{ Piano 16 to 5,200 cycles. Violin 192 to 3,072 cycles. Bass Viol 40 to 240 cycles.
Wind Instruments	{ Bass Tuba 44 to 340 cycles. Trumpet 160 to 960 cycles. Piccolo 512 to 4,608 cycles.
Human Voice	{ Bass 80 to 340 cycles. Tenor 128 to 480 cycles. Soprano 240 to 1,152 cycles.

PREFIXES

Deci-	= one-tenth.
Centi-	= one-hundredth.
Mil- or Milli-	= one-thousandth.
Micro-	= one-millionth.
Kilo-	= 1,000 times.

MODULATED DIRECT CURRENT

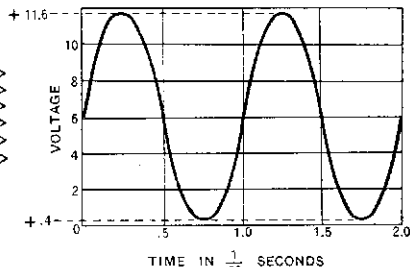
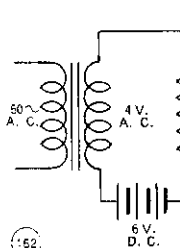
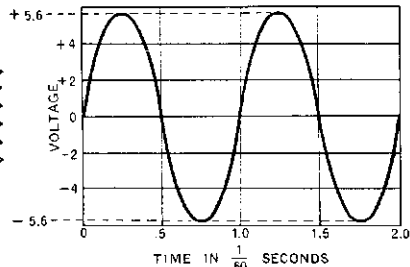
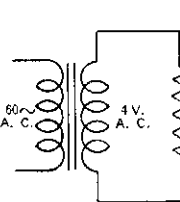
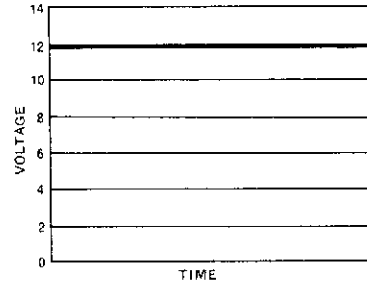
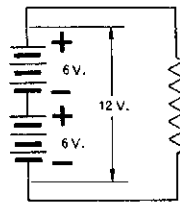
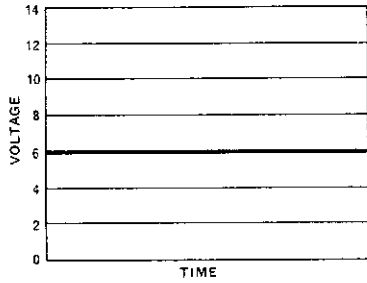
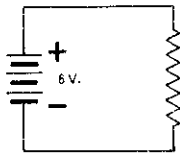

FIG. 5. GRAPHS OF D. C., A. C. AND MODULATED D. C.

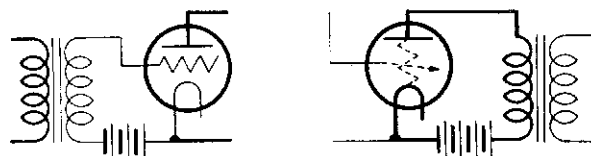

FIG. 5-A. WHEN A TUBE IS IN NORMAL OPERATION THE VOLTAGE ON THE GRID AND ON THE PLATE IS MODULATED OR PULSATING D. C.

In direct current (D. C.) circuits, the polarity or positive (+) and negative (-) terminals remain the same at all times. Thus the carbon terminal of a dry cell is always positive with respect to the zinc (negative) terminal.

If the voltage or current of a direct-current circuit remains at one value it is termed **smooth direct current**. If the voltage or current does not remain constant but varies up and down, it is termed **pulsating or modulated direct current**.

Some form of modulated direct current is present in the grid and plate circuits of practically every tube in a radio receiver, consequently it is very important to understand the nature of this type of current.

The drawings on this page illustrate the nature of modulated direct current by showing how a direct current and an alternating current (A. C.) may be combined to produce modulated direct current.

At the top is a graph of the voltage of a battery. The voltage is six, and it remains at this value during the time indicated.

In the second drawing, two six-volt batteries are connected in series. The total voltage is twelve, and it maintains this value for the time indicated.

The third drawing shows two cycles of a four-volt sixty-cycle alternating-current supply. It will be seen that the voltage starts from zero, rises to a positive peak of 5.6 volts (the peak is about 1.4 times the effective value, as described on Page 11), decreases to zero, then increases to a negative peak of 5.6 volts, and returns to zero. This completes one cycle and requires $\frac{1}{60}$ of a second.

If a direct current and a lower-value alternating current are combined in one circuit, the result is a modulated direct current.

Thus in the fourth drawing, four-volts A. C. and six-volts D. C. are connected in series. The battery voltage remains constant but the A. C. voltage varies between +5.6 volts and -5.6 volts. At any particular instant the total voltage is equal to the sum of the battery voltage and the voltage of the A. C. at that particular instant.

When the A. C. voltage is zero, the total voltage is $6 + 0$ or 6 volts. When the A. C. voltage is at its positive peak, the total voltage is $6 + 5.6$ volts or 11.6 volts. When the A. C. voltage is at its negative peak, the total voltage is $6 + (-5.6)$ volts or +.4 volts. The voltage across the resistor therefore varies between a minimum of +.4 volts and a maximum of +11.6 volts.

Modulated direct current may be compared to a cross section of the ocean. The depth of the water represents the D. C. voltage, and the waves on top represent the A. C. voltage. If the A. C. component (portion) is small compared to the D. C. component, we say that the D. C. voltage has an A. C. ripple. The terms pulsation, modulation, and ripple are sometimes used interchangeably.

In radio circuits, the A. C. component is the only useful part of modulated D. C. If we want to rock a boat, we need high waves but the depth of the water is not so important: Waves ten feet high in water twenty feet deep will rock a boat just as much as waves ten feet high in water 1,000 feet deep.

When we speak of the A. C. voltage on the grid or plate of a tube, we mean the A. C. component of the modulated D. C. voltage in the grid or plate circuit.

In order to keep the grid negative at all times we use a negative "bias" voltage of slightly greater value than the highest allowable positive voltage peak of the applied A. C. signal. Under these conditions the grid voltage never swings positive.

In the plate circuit of a tube, the action of the applied grid voltage is to increase and decrease the internal plate-cathode resistance, thus correspondingly increasing or decreasing the plate current above and below its normal value, but the plate current of a normally-operated tube never reverses.

It should be understood that the modulation does not have to be plain A. C.; it may be an irregular pulsation. The frequency may be R. F., I. F. or A. F. and these may be modulated by a lower frequency as explained on the next page.

MODULATED RADIO FREQUENCY

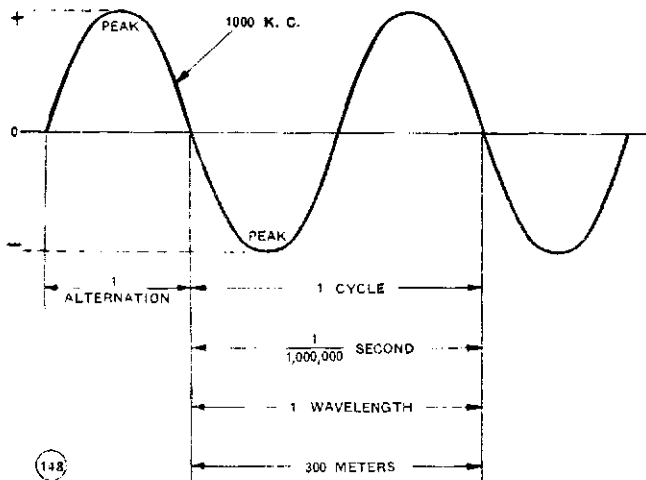

FIG. 6. TWO CYCLES OF A 1,000 K. C.-PER-SECOND SIGNAL.

In **alternating current (A. C.)** the polarity or positive and negative terminals reverse periodically. Thus one terminal of an A. C. generator is first positive with respect to the other terminal, then it changes to negative, then back to positive, and so on. The polarity alternates.

The **term negative** in reference to A. C. does NOT mean less than nothing. Negative merely means that the polarity of the voltage is reversed. The negative peak has the same force as the positive peak.

The value of an alternating current is continually changing. When we speak of four volts A. C., we mean the **effective value** which is equal to the value of a direct current that would produce the same heating effect. Actually the peak of a sine wave of alternating current is approximately 1.4 times the effective value. The effective value is approximately .7 of the peak.

A **cycle** of A. C. is the action in which the current starts from zero, passes through one peak, then through the reverse peak, and returns to zero.

An **alternation** is half of a cycle.

Frequency is the number of cycles in a given time, usually one second. Radio frequencies are generally expressed in kilocycles (K. C.) per-second. One K. C. equals 1,000 cycles.

The **speed** of electro-magnetic waves is approximately 186,000 miles or 300,000,000 meters per second.

In an electro-magnetic wave of one cycle-per-second, the beginning of the cycle will be one second or 300,000,000 meters away from the end of the cycle so the wave length is 300,000,000 meters. If there are two cycles-per-second, the beginning of a cycle will be one-half second or 150,000,000 meters away from the end of the cycle. If there are 1,000,000 cycles-per-second, the wavelength is 300 meters, and so on. Frequency may be converted to wavelength and vice versa as follows:

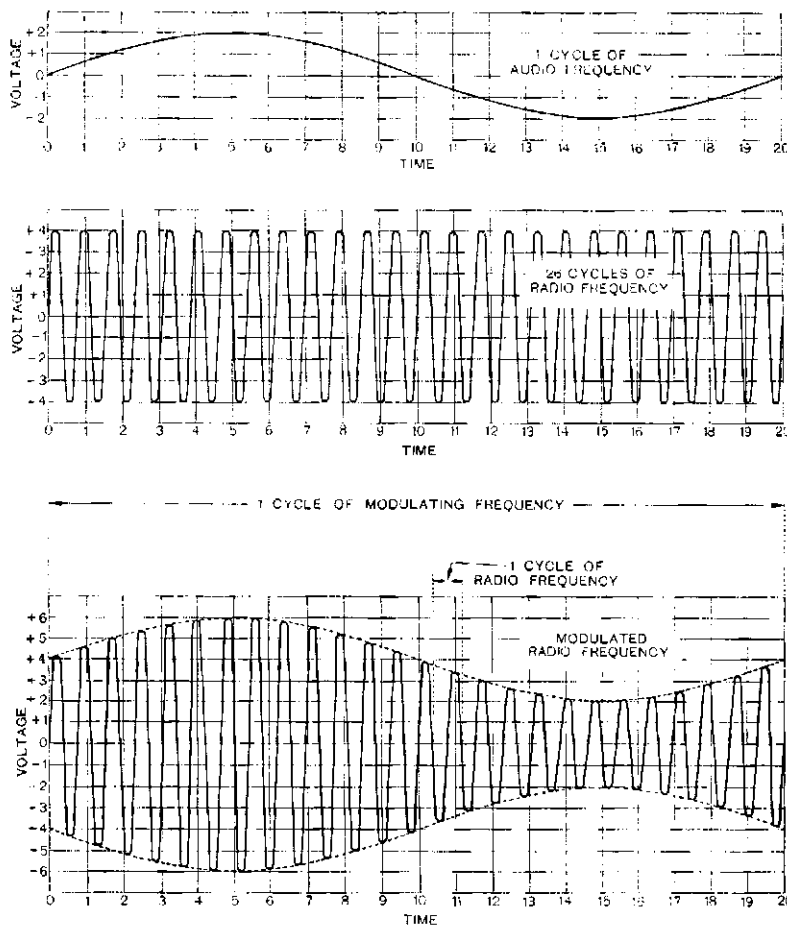

FIG. 6-A. ILLUSTRATING HOW A RADIO-FREQUENCY "CARRIER" IS MODULATED. In these graphs, each unit of time represents one-hundred thousandth of a second (.00001 second). The audio frequency is therefore 5,000 cycles-per-second, and the radio frequency is 130,000 cycles-per-second.

Modulated Radio Frequency (Continued)

Wavelength in meters = 300,000 divided by frequency in kilocycles.

Frequency in kilocycles = 300,000 divided by wavelength in meters.

Electro-magnetic frequencies cover from less than one cycle-per-second up to trillions of cycles-per-second. A table of electro-magnetic frequencies will be found elsewhere in this section. The particular range of frequencies used in radio has been chosen because it is best suited for this work. However, higher frequencies than those in the radio range, such as invisible infra-red frequencies and visible light frequencies can and have been used for transmission as **carriers** of voice impulses.

If the peak voltage or amplitude of an alternating current remains constant, it is usually termed a **continuous wave** (C. W.). If the peak voltage or amplitude of an alternating current does not remain constant, but varies up and down from its effective value, it is termed **modulated alternating current**.

In radio we are mostly concerned with radio-frequency energy modulated at an audio frequency rate.

The process of modulation is illustrated in Figure 6-A. The second graph represents unmodulated R. F. Note that the peak voltage of each alternation remains constant. In radio telephony, the unmodulated R. F. is termed the **carrier**. When the carrier is modulated, the peak voltage changes up and down from its normal value as shown in the bottom graph.

The R. F. carrier is inaudible; even if the loud speaker could respond to such high frequencies, they would be outside the range of our hearing.

It is the audio modulation or **change in amplitude** (voltage or intensity) of the carrier that produces audible sound in the speaker after passing through the receiver. The greater the **percentage of modulation** or change in amplitude, the louder the audible response.

The **percentage of modulation** is the ratio of half the difference between the maximum and minimum amplitudes of a modulated wave to the average amplitude, expressed in per cent.

In the bottom graph, Figure 6-A, the modulation is 50%. To get 100% modulation, the carrier would have to change from zero up to twice its normal (unmodulated) value.

Detection

After the modulated R. F. signal has been received, it must be rectified before it can be used to produce sound.

Rectification is accomplished by the detector which suppresses the effects of one side of the R. F. alternations, and allows the audio modulation of the remaining side to affect the phones or audio amplifier.

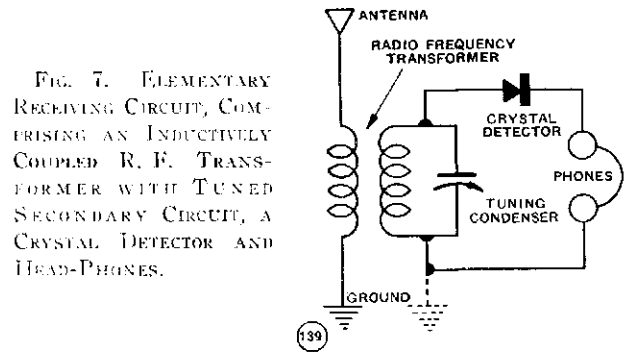

FIG. 7. ELEMENTARY RECEIVING CIRCUIT, COMPRISING AN INDUCTIVELY COUPLED R. F. TRANSFORMER WITH TUNED SECONDARY CIRCUIT, A CRYSTAL DETECTOR AND HEAD-PHONES.

An elementary receiving circuit requires an **antenna** and ground circuit to pick up energy from the passing electro-magnetic waves, a **tuner** to select the energy of the desired frequency, a **detector** to rectify the signal, and a **sound reproducer** to convert the modulation of the rectified signal into sound.

The signal may be amplified either before or after it is rectified, or both. If amplified before, it is a radio-frequency amplifier. If amplified after, it is an audio-frequency amplifier.

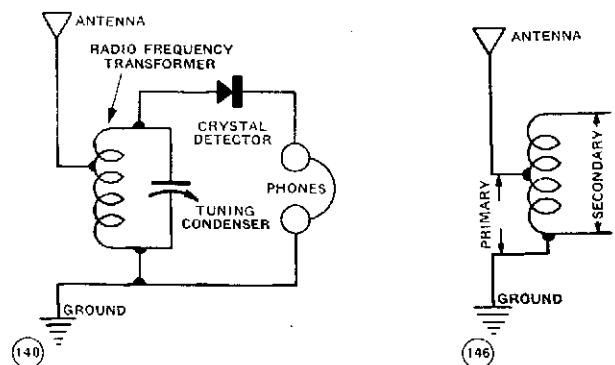

FIG. 7-A. AUTO-TRANSFORMER TYPE OF COUPLING IS USED ABOVE.

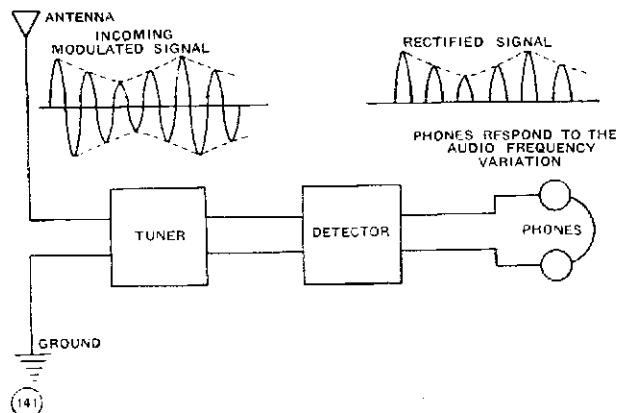

FIG. 7-B. THE DETECTOR SERVES TO CUT OFF ONE SIDE OF THE R. F. ALTERNATIONS.

ACTION OF TRANSMITTER AND RECEIVER

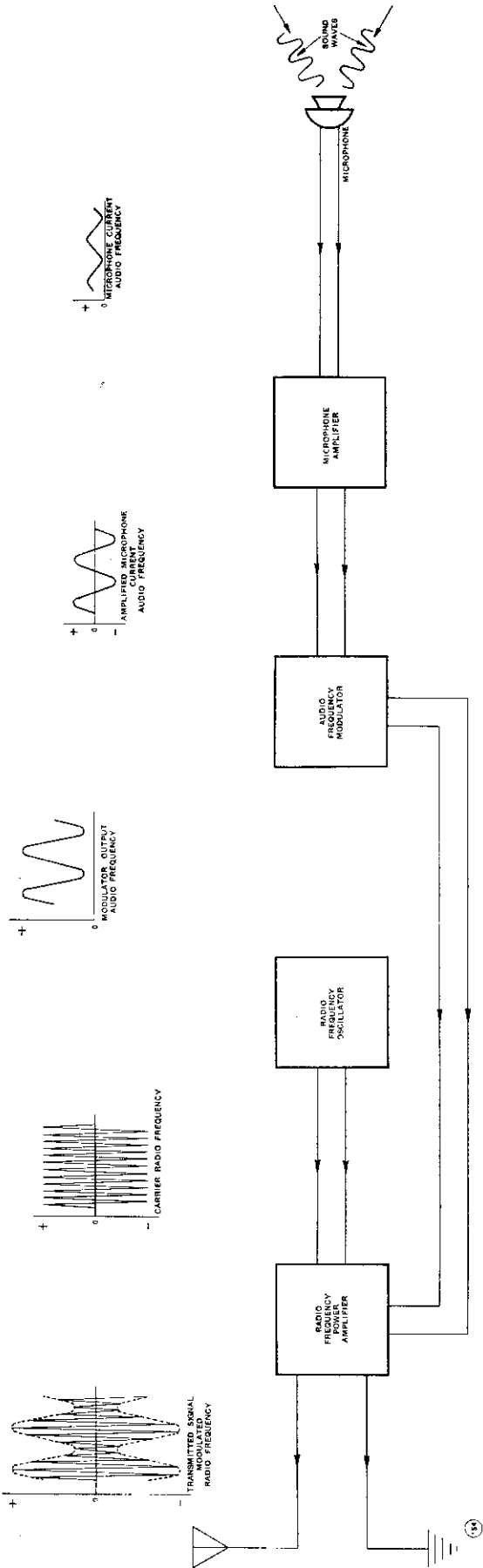

FIG. 8. FUNCTIONAL DIAGRAM OF A TRANSMITTER, INDICATING THE TYPE OF CURRENT IN EACH SECTION.

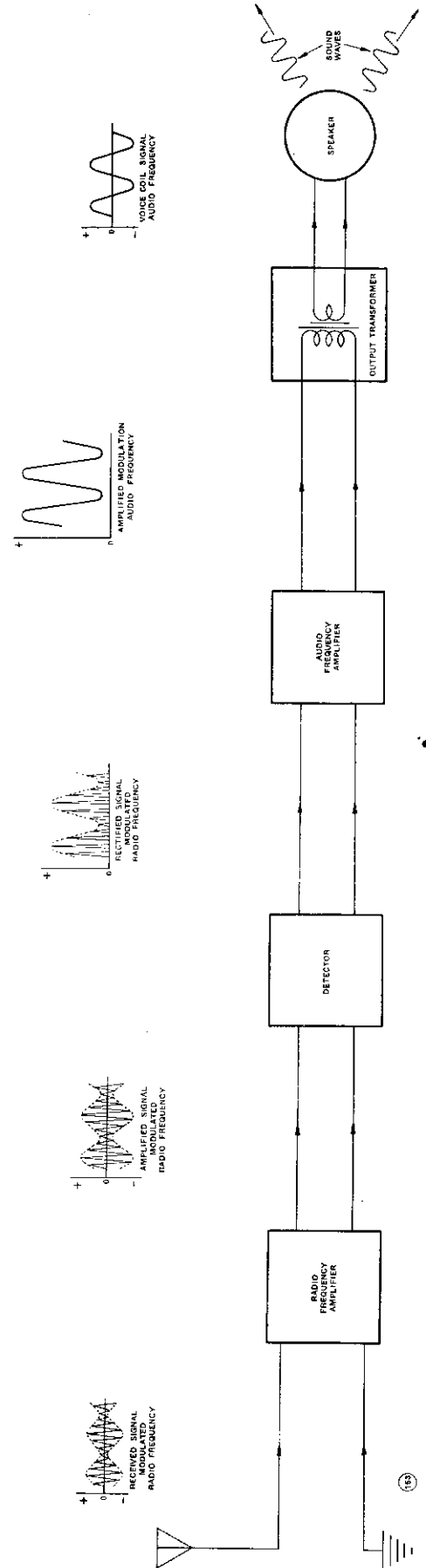
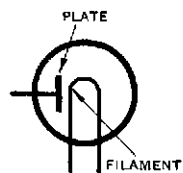
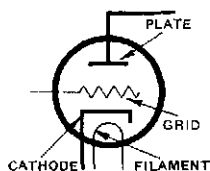

FIG. 8-A. FUNCTIONAL DIAGRAM OF RECEIVER SHOWING HOW THE RECEIVED R. F. SIGNAL IS AMPLIFIED AND RECTIFIED AND HOW THE MODULATION OF THE RECTIFIED SIGNAL IS FURTHER AMPLIFIED AND FED INTO THE SPEAKER.

TUBE SYMBOLS AND SOCKET IDENTIFICATION



HALF-WAVE RECTIFIER. Current passes through the tube only every other half-cycle when the plate is positive. The current flow is only in one direction, or rectified.



TRIODE (THREE-ELEMENT) HEATER-TYPE TUBE. Detector, amplifier, and oscillator. The '27 tube is an example of this type.

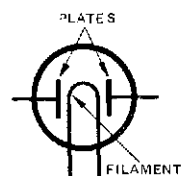

FULL-WAVE RECTIFIER. When connected as shown in Fig. 22, on Page 24, current passes in the same direction through the tube during each half-cycle of the alternating-current supply. One plate functions during one-half cycle, and the other plate functions during the next half-cycle.

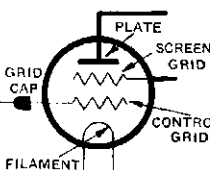

TETRODE (FOUR-ELEMENT) SCREEN-GRID PLAIN-FILAMENT-TYPE TUBE. This tube is used for radio-frequency or intermediate-frequency amplification. It provides much greater amplification than corresponding triode tubes. It is also employed as a detector. The '23 tube is of this type.

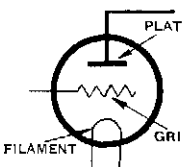

TRIODE (THREE-ELEMENT) PLAIN-FILAMENT TUBE. This type of tube is used as amplifier, detector and oscillator. A few examples of this type are the '199, '201-A, '226 and '245.

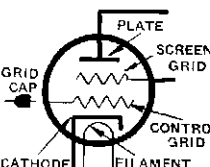

TETRODE (FOUR-ELEMENT) SCREEN-GRID HEATER-TYPE TUBE. Used as amplifier or detector in R.F. or I.F. circuits with A.C.-filament supply. The '24 tube is an example of this type.

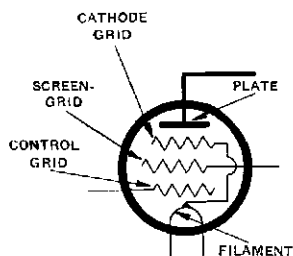

PENTODE (FIVE-ELEMENT) SCREEN-GRID PLAIN-FILAMENT TYPE TUBE. Used as a power output tube. Provides high amplification and high power output.

AMPLIFICATION FACTOR: A measure of the effectiveness of the grid voltage relative to that of the plate voltage in affecting the plate current.

MUTUAL CONDUCTANCE: The ratio of the change in plate current to the change in grid potential producing it, under the condition of constant plate voltage.

POWER AMPLIFICATION: The ratio of the alternating-current power produced in the output circuit to the alternating-current power supplied to the input circuit.

VOLTAGE AMPLIFICATION: The ratio of the alternating voltage produced at the output terminals of an amplifier to the alternating voltage impressed at the input terminals.

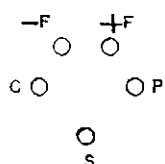

Heater-Type (A.C.) Screen-Grid Four-Element Tube

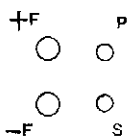

Battery-Type (D.C.) Screen-Grid Four Element Tube

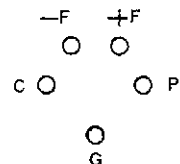

Heater Type (A.C.) Three-Element Tube

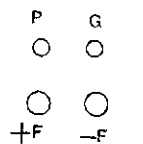

Plain Filament (A.C. or D.C.) Three-Element Tube

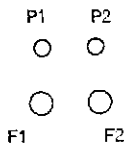

Full-Wave Rectifier Tube

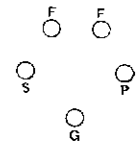

Plain Filament (A.C. or D.C.) Five-Element Pentode

SOCKET CONNECTIONS FROM BOTTOM

On some sockets, the +F and -F are reversed.

The markings -F and +F on A.C. sockets are used only for identification purposes, as the A.C. filaments have no fixed polarity.

RADIO TUBES

A radio tube may be thought of as an ultra-sensitive relay that will operate from exceedingly small input power of direct voltage, or alternating voltage of any frequency, and release locally-supplied energy of much greater intensity than the input power.

But even the very best mechanical relay could not begin to duplicate the versatile and amazing properties of a radio tube.

The radio tube has no mechanical action; the input voltage, without loss to itself, controls a stream of electrons inside the tube, which is caused to flow by a local source of electrical energy.

(a) Elements in Radio Tube

In a three-element tube such as the 201-A, 226, 171-A, 245, 250, etc., there are three elements or electrodes (see Fig. 10):

1. **The filament**, which is heated by a low-voltage source of electricity, emits or gives off electrons, which have a negative charge of electricity.

2. **The plate**, which is maintained at a high positive voltage with respect to the filament, surrounds the filament and it attracts the negatively-charged electrons, so that a stream of electrons flows from the filament to the plate.

This stream of electrons provides a path for current to pass from the plate to the filament. The strength of

this plate-circuit current depends on the number of electrons flowing from filament to plate.

Increasing the electron-flow increases the plate-circuit current; decreasing the electron-flow decreases the plate-circuit current.

3. **The grid**, which is placed between the filament and plate, acts to control the number of electrons flowing from the filament to the plate; this control is exercised by the voltage on the grid with respect to its filament.

When the grid voltage is made negative with respect to the filament, the grid repels the electrons from the filament and therefore diminishes the flow of electrons from filament to plate. This decreases the plate-circuit current.

When the grid voltage is made less negative with respect to its filament, the repelling action of the grid on the electrons becomes less, consequently more electrons flow from filament to plate. This increases the plate-circuit current.

The grid, through the action of its voltage, acts as a gate or valve to control the flow of electrons from filament to plate, and it thus exercises complete control on the plate-circuit current.

There is no time-lag in this control. Even if the grid voltage varies up and down millions of times each second, it will produce a corresponding variation in the plate-circuit current.

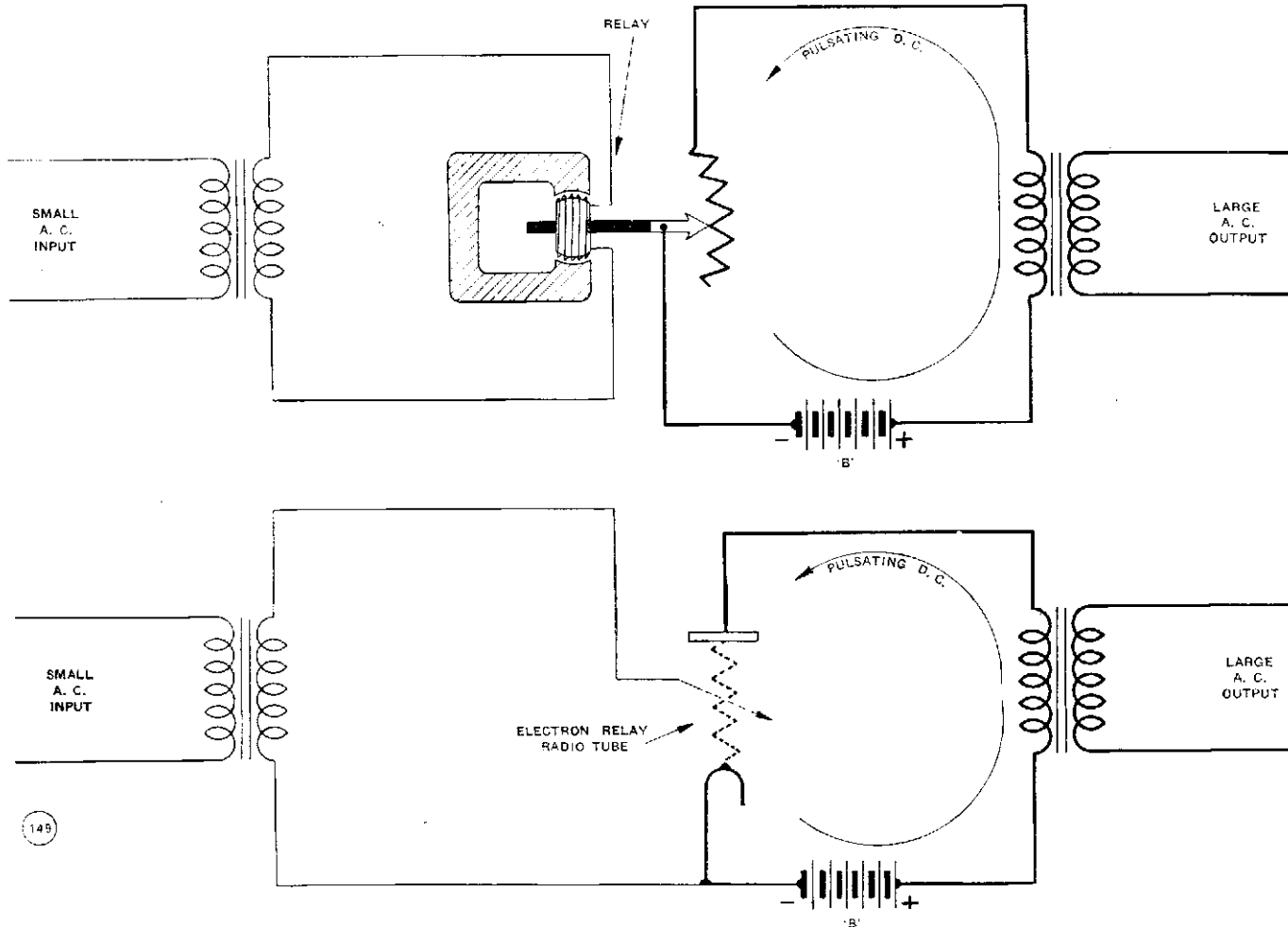

FIG. 9. ANALOGY BETWEEN MECHANICAL RELAY AND RADIO TUBE.

In the top view a mechanical relay operating from a low input voltage, controls a large output by varying the value of a resistor in the output circuit. This is analogous to the action of a radio tube in which a small input voltage on the grid controls the internal plate-to-filament resistance and thus produces a large output from the local "B" supply.

Radio Tubes (Continued)

The plate-circuit current follows the form of the grid voltage very closely, so that the output of the tube is a close duplicate of the input energy. In other words, when the tube is properly operated, there is no distortion.

For battery-operated tubes, three batteries are used:

1. The "A" or filament battery, which heats the filament.
2. The "B" or plate-circuit battery, which makes the plate positive with respect to the filament.
3. The "C" or grid-bias battery, which is used for the reasons given below.

(b) Necessity for Negative Grid Bias

If the grid voltage becomes even slightly positive with respect to the filament (or cathode), electrons will flow from filament to grid, and current will pass from grid to filament.

This is equivalent to placing a varying resistance load across the grid (input) circuit at such moments that the grid is positive.

If this condition exists in an audio-frequency amplifier, it produces distortion and decreased amplification. In a radio-frequency amplifier, it produces decreased amplification and broadened tuning.

For these reasons it is imperative in an amplifying-tube circuit that the grid be kept negative with respect to the filament (or cathode) at all times.

The negative bias must not be too great, otherwise another form of distortion will occur. The correct bias is determined from the characteristics of the tube at the operating voltages.

(c) A. C.-Filament Type of Three-Element Tube

As the number of electrons emitted by the filament depends on the temperature of the filament, it is im-

portant that the filament temperature be maintained constant, otherwise an undesired variation in the plate-circuit current will be produced.

Also, changes of voltage at any point on the filament is equivalent to changing the grid voltage with respect to that point on the filament. This will produce an undesired variation in the electron flow. This condition is encountered if we use a high A. C. voltage to heat the filament.

Therefore in A. C.-filament tubes, the filament is designed to operate at low voltages and also to have slow heating qualities. In these tubes, the change in voltage at any point on the filament is so small that its effect on the electron flow is very slight.

(d) Heater-Type Tubes

The heater-type tube is a considerable improvement over the plain A. C.-filament tube in the reduction or elimination of hum.

The heater-type tube has a filament inside a porcelain tube. A "cathode" surrounds the porcelain tube. It consists of a cylinder of metal on which is deposited a substance which freely emits electrons when heated.

The filament heats the cathode. The cathode, when heated, gives off electrons. The filament and cathode may be regarded as one element.

Owing to the construction of the cathode, it maintains a constant temperature and the same voltage all over, even when A. C. is used to heat the filament.

The electrons emitted by the cathode are attracted to the plate, and this flow of electrons is controlled by the grid in the manner previously described.

The symbol for a heater-type three-element vacuum-tube is shown in Fig. 11.

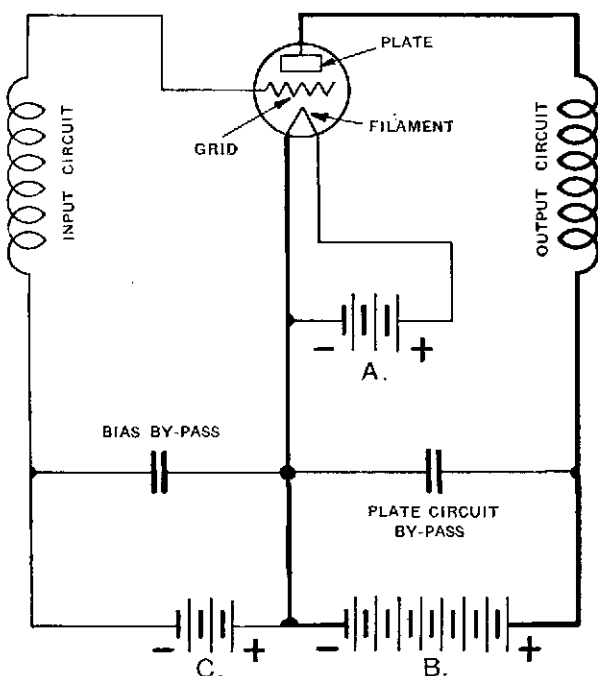

FIG. 10. THREE-ELEMENT VACUUM-TUBE CIRCUIT WITH PLAIN FILAMENT.

The output, or plate circuit, is shown in heavy lines.

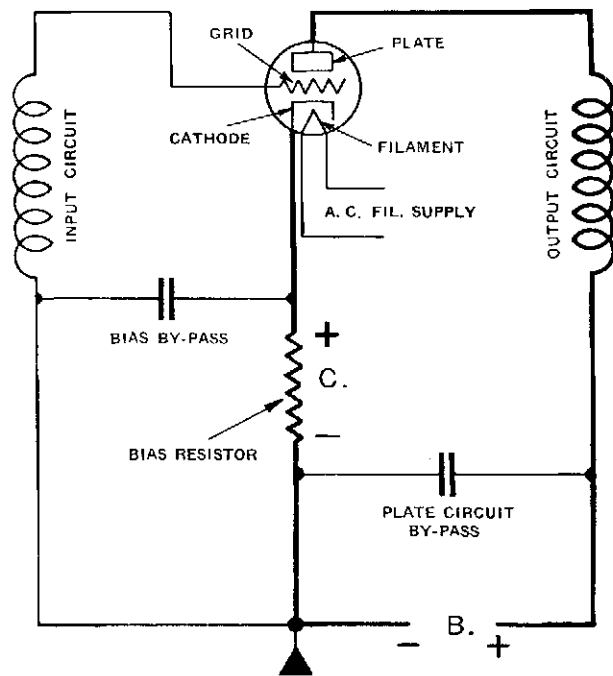

FIG. 11. HEATER TYPE THREE-ELEMENT VACUUM-TUBE CIRCUIT.

Radio Tubes (Continued)

(e) Screen-Grid Tubes

The screen-grid tube is similar in construction to the regular three-element tube, except that an additional element, the screen, or screen-grid has been added. This screen, in the form of a spiral of wire, is placed between the control-grid and the plate. The screen also covers the top and the outside of the plate, and the bottom of the control-grid, thus completely shielding the control-grid from the plate.

The symbol for a plain-filament type of screen-grid tube is shown in Fig. 12.

In this diagram it will be noted that the screen is maintained at a positive voltage with respect to the filament.

Electrons, attracted by the positive charge on the screen flow from the filament and pass through the spaces between the wires of the control grid. Most of these electrons pass through the spaces in the screen wires and, owing to the high plate voltage, go to the plate.

The sensitivity or amplification of the screen-grid tube depends, among other things, on the screen voltage. Greatest amplification is secured when the screen is operated at its maximum rated value. The amplification decreases as the screen voltage is decreased. By making the screen voltage adjustable, the output volume of the set may be controlled. The methods of obtaining suitable ranges of screen voltage are described later.

For radio-frequency amplification the screen-grid tube has two very important advantages over the ordinary three-element tube.

First: In a three-element tube, at a given moment while a signal is being received, the following action takes place:

- (1) When the control-grid becomes more negative—
- (2) the electron flow decreases—
- (3) but the plate voltage increases—
- (4) and this tends to increase the electron flow.

From this it will be seen that (2) and (4) oppose each other, thus limiting the available amplification of the tube. (This opposition is present also when the control-grid is becoming less negative.)

In a screen-grid tube, the action is different:

- (1) When the control-grid becomes more negative—
- (2) the electron flow decreases—
- (3) and the voltage on the plate increases—
- (4) but, owing to the influence of the screen, the increase of plate voltage does not tend to increase the flow of electrons.

Therefore, in the screen-grid tube, there is negligible opposition to the control by the grid of the electron stream. As a result, the available amplification is increased.

The action of the screen in shielding the electron stream in the tube from voltage changes on the plate is the main reason why the actual R. F. amplification of the screen-grid tube is rated at about 50, compared to about 8 for the old-style three-element tube.

Second: The high amplification of the screen-grid tube could not be utilized in R. F. circuits if it were not for the fact that the screen also eliminates capacity coupling between the plate and grid electrodes within the tube, and thus prevents the possibility of feed-back between these two elements.

A more detailed explanation of this action is given on Pages 7 to 14, inclusive, of a booklet (Ser. D. 59) entitled "A Description of the New Atwater Kent Screen-Grid Receivers."

(f) The Pentode Tube

The pentode tube is a five-element power amplifier. It has twice the available undistorted output and six times greater amplification than the customary three-element output tube.

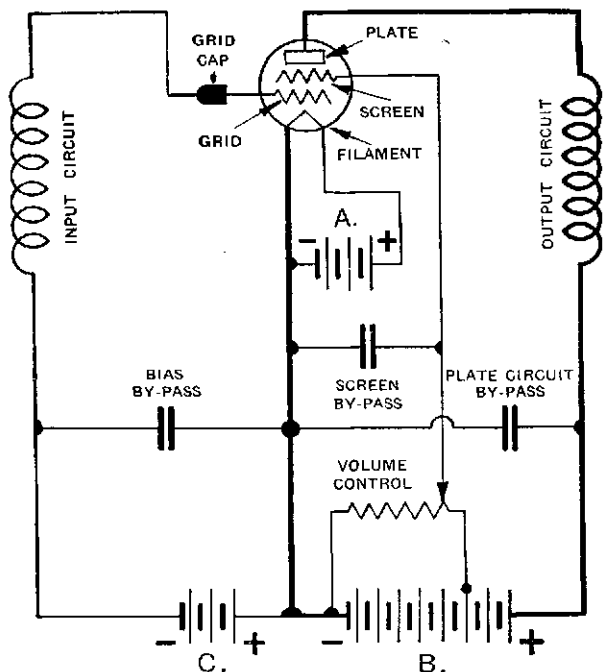

FIG. 12. FOUR-ELEMENT (SCREEN-GRID) VACUUM-TUBE CIRCUIT WITH PLAIN FILAMENT.

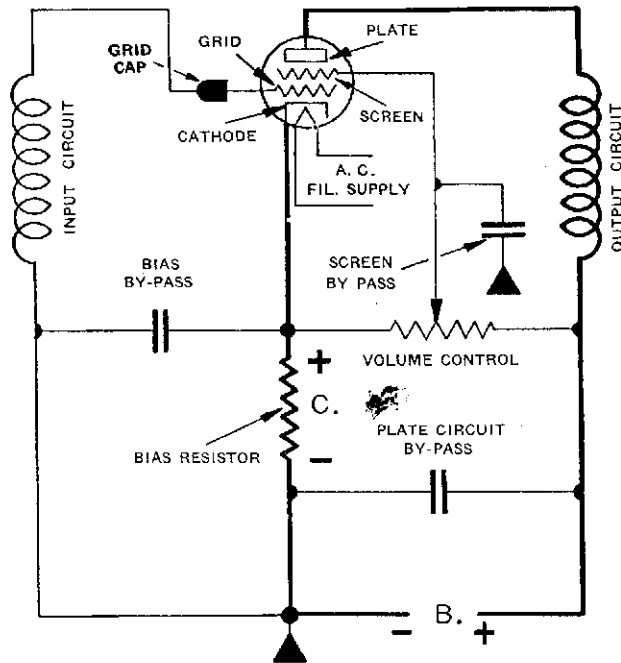

FIG. 13. HEATER-TYPE FOUR-ELEMENT (SCREEN-GRID) VACUUM-TUBE CIRCUIT.

Radio Tubes (Continued)

The principle of the screen-grid tube is utilized in the pentode to secure exceedingly high audio-frequency amplification. In addition, the pentode has one extra element, the cathode-grid, that enables the pentode to handle large output power.

In order to appreciate the advantage of the pentode, it is necessary to understand an action, termed secondary emission, that limits the available power output of an ordinary screen-grid tube.

There are three points to consider:

First.—A screen-grid tube that is intended for use as a power output tube must have a high plate current. To accomplish this, it is necessary to use a high voltage on the screen-grid (about as high as the plate voltage).

Second.—To secure the largest possible output from a tube, it is necessary to have the largest possible voltage variation across the output circuit of the tube. In other words, the variation of plate voltage (resulting from the impressed signal) must be as large as possible.

Thus if the normal plate voltage of a tube is 250 volts, greatest output will be secured if the plate voltage variations run from 250 volts down nearly to zero, then up to almost 500 volts, then back towards zero, and so on.

From this it will be seen that the plate voltage must decrease considerably below its normal value during one-half the cycle of the impressed signal. The screen voltage remains constant, and if it equals the normal plate voltage, it will be readily seen that during one-half the cycle of the impressed signal, the plate voltage becomes less than the screen voltage.

Third.—In a screen-grid tube, when electrons hit the plate they tend to dislodge other electrons from the plate. When the plate voltage is less than the screen-grid voltage, the dislodged or secondary electrons will flow from the plate to the screen-grid. This flow of secondary electrons away from the plate is just opposite to the desired flow of electrons towards the plate. If this secondary emission becomes appreciable, it makes the tube useless as a power amplifier.

(In an R. F. screen-grid tube, the plate voltage is always higher than the screen voltage, so the secondary electrons fall back on the plate and cause no harm.)

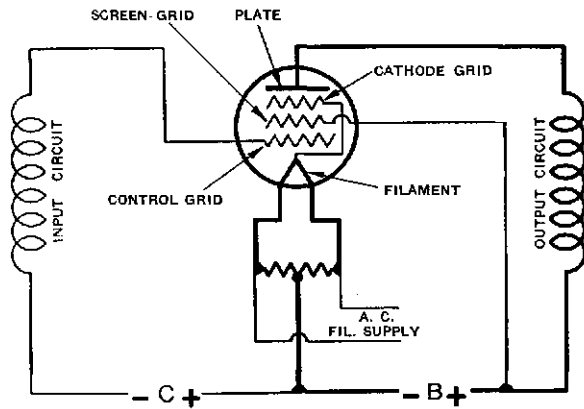

FIG. 14. FIVE ELEMENT (PENTODE) POWER TUBE WITH PLAIN FILAMENT.

From these three points we can realize that in order to get large power output from an ordinary screen-grid tube we encounter conditions that promote secondary emission and thus nullify our aim.

In the pentode tube, the effects of secondary emission are eliminated by the addition of an extra element, the cathode-grid, which is placed between the screen-grid and the plate, and is connected internally to the centre-point of the filament.

The secondary electrons emitted from the plate find themselves surrounded by the zero-potential cathode-grid, through which they would have to pass in order to reach the screen-grid. As the electrons have a negative charge they are repelled from the cathode-grid and are attracted by the positive voltage on the plate, even when the plate voltage is low, so they fall right back onto the plate and therefore have no effect whatsoever on the action of the tube.

The addition of the cathode-grid makes it possible to use a high screen-grid voltage, and also allows the plate-voltage variations to decrease almost to zero, thus providing high output power without any ill-effects from secondary emission.

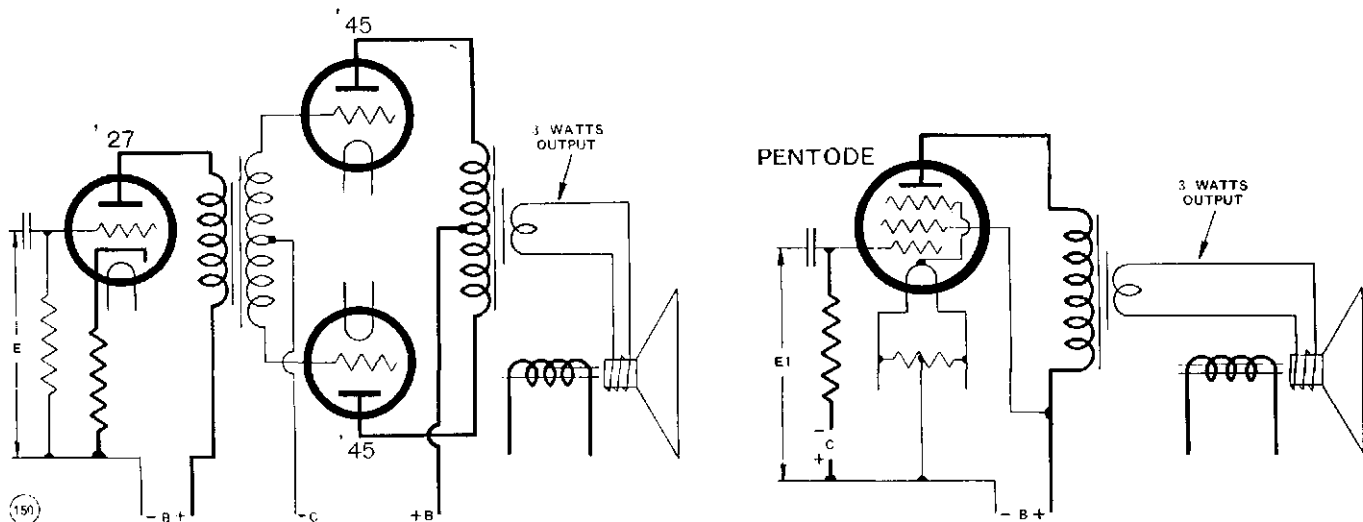

FIG. 15. ONE PENTODE DOES THE WORK OF THREE ORDINARY TUBES.

For the same input voltage at E and E1, the one pentode provides as much audio amplification and power output as the combination of one '27 and two '45s.

AN EXPLANATION OF THE ACTION OF ATWATER KENT TUNED-R. F. SCREEN-GRID RECEIVERS

Some idea of the action of Atwater Kent tuned-R. F. screen-grid receivers may be gained by studying the diagram of early Model 55 and 55-C in Fig. 15-A.

We will first briefly review the nature of radio broadcast energy, then consider the receiving circuit, and finally the power supply system in A.C.-operated models.

A. Energy Radiated from Transmitter

The electro-magnetic energy radiated by the antenna of a broadcast station has a definite normal frequency somewhere in the broadcast range of radio frequencies. The broadcast range extends from 550,000 cycles-per-second to 1,500,000 cycles-per-second. (This may also be expressed as 550 K. C. to 1,500 K. C., where K. C. is the abbreviation of kilocycles and is equivalent to 1,000 cycles-per-second.)

This normal operating frequency of a broadcast station is known as the "carrier" or carrier frequency.

When the broadcast station is transmitting voice or music, the audible sound, operating through a micro-

phone and amplifier, causes audio-frequency variations in the strength, or intensity, of the carrier frequency.

This variation of the strength of the carrier frequency is known as modulation. The carrier frequency is inaudible. It is the effect of the audio-frequency variation of intensity of the carrier, i. e., the modulation, that produces audible sound in the speaker after passing through the receiver.

The audible sound from the speaker, caused by the modulation of the carrier, is a close duplicate of the original sound at the transmitter.

(Note.—In many of the diagrams in this section of the Manual, we have intentionally omitted the by-pass condensers in order to make the diagrams clearer. Also note that it is standard engineering practice to measure the plate, screen, and grid voltages of a tube with respect to the cathode terminal in heater-type tubes, and with respect to the negative filament terminal (—F) in plain-filament type tubes. This practice is followed closely in the service manual.)

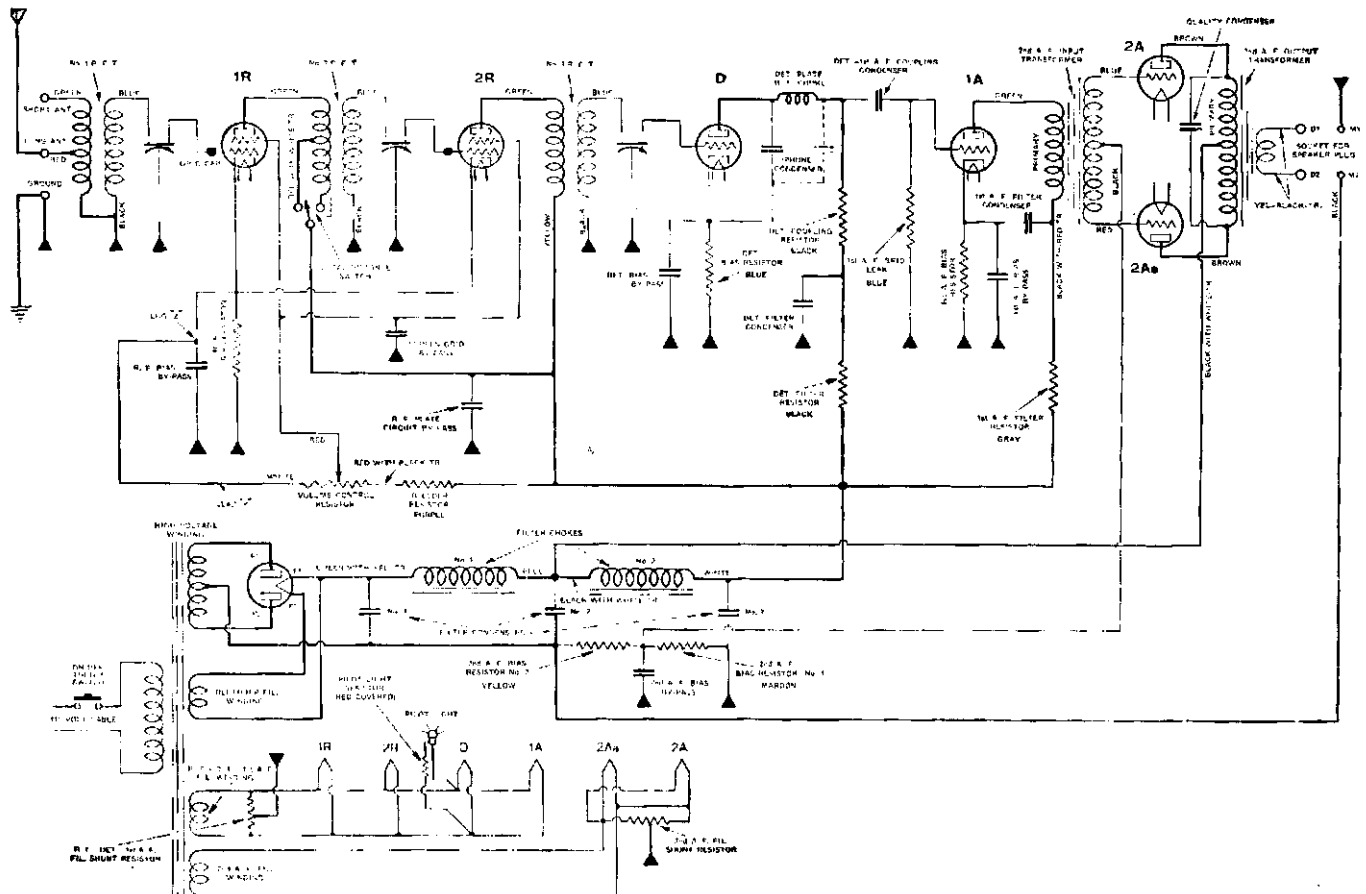

FIG. 15-A. CIRCUIT DIAGRAM OF EARLY MODEL 55 AND 55-C WITH TRANSFORMER COUPLED R. F. AMPLIFIER.

This circuit has two stages of screen-grid radio-frequency amplification, plate-detection, one stage of resistance-coupled audio-frequency amplification, and a "double-audio" output stage. Volume is controlled by changing the screen voltage of both R. F. tubes. An explanation of the action of this circuit is given in the accompanying text.

B. TUNED-R. F. SCREEN-GRID AMPLIFIER

A very small portion of the electro-magnetic energy radiated by the antenna of the broadcast station is intercepted in the antenna circuit of the receiver. It then acts upon the radio-frequency amplifier in the manner described below.

(a) Action of R. F. Amplifier with Transformer Coupling

In the early type of Atwater Kent screen-grid receivers, the R. F. transformers are of the usual inductively-coupled type as shown in Fig. 16. Each of these transformers has a primary winding and a secondary winding.

(b) Action of No. 1 R. F. T.

The electro-magnetic R. F. energy intercepted by the antenna causes an R. F. voltage to be developed in the antenna circuit which causes a current flow through the primary of No. 1 R. F. T.

The current in the primary coil sets up a magnetic R. F. field around the coil. This field "cuts" the turns of the secondary coil and induces a voltage in the secondary. This voltage is greater as the voltage across the primary becomes greater.

If the transformer is not tuned to the frequency of the signal, the voltage across the primary will be small and hence also the secondary voltage will be small.

When the transformer is tuned to the signal frequency, the voltage across both the primary and secondary coils will be a maximum and thus the maximum voltage will be applied to the input of the 1st-R. F. tube.

(c) Action of the 1st-R. F. Tube

The R. F. voltage across the secondary of No. 1 R. F. T. is applied to the grid and cathode of the 1st-

R. F. tube. This causes an R. F. variation in the grid voltage of the 1st-R. F. tube.

The varying grid voltage affects the electron-flow between cathode and plate, thus producing variations in the plate-circuit current. These variations in the plate-circuit current are identical in form to the antenna-current variations, but of much greater intensity, owing to the amplifying properties of the 1st-R. F. screen-grid tube.

(d) Coupling Between 1st- and 2nd-R. F. Tubes

The R. F. variations or pulsations in plate-circuit current set up a corresponding R. F. voltage across the primary of No. 2 R. F. T., which is a maximum when the secondary circuit is tuned to the frequency of the pulsations in the primary circuit. The induced R. F. voltage across the secondary of No. 2 R. F. T. is likewise a maximum under this condition.

(e) Action of 2nd-R. F. Tube

The R. F. voltage across the secondary of No. 2 R. F. T. causes a variation in the grid voltage of the 2nd-R. F. tube. The grid-voltage variation affects the cathode-plate electron-flow and produces current variations in the plate circuit of the 2nd-R. F. tube. These pulsations are similar to those in the 1st-R. F. plate circuit, but of much greater intensity, owing to the amplifying properties of the 2nd-R. F. screen-grid tube.

(When a 3rd stage of radio-frequency amplification is used, its action is similar to that of the 2nd-R. F. stage.)

(f) Coupling Between 2nd-R. F. and Detector Tubes

The current-variations or pulsations in the plate circuit of the 2nd-R. F. tube set up an R. F. voltage across the primary of No. 3 R. F. T.

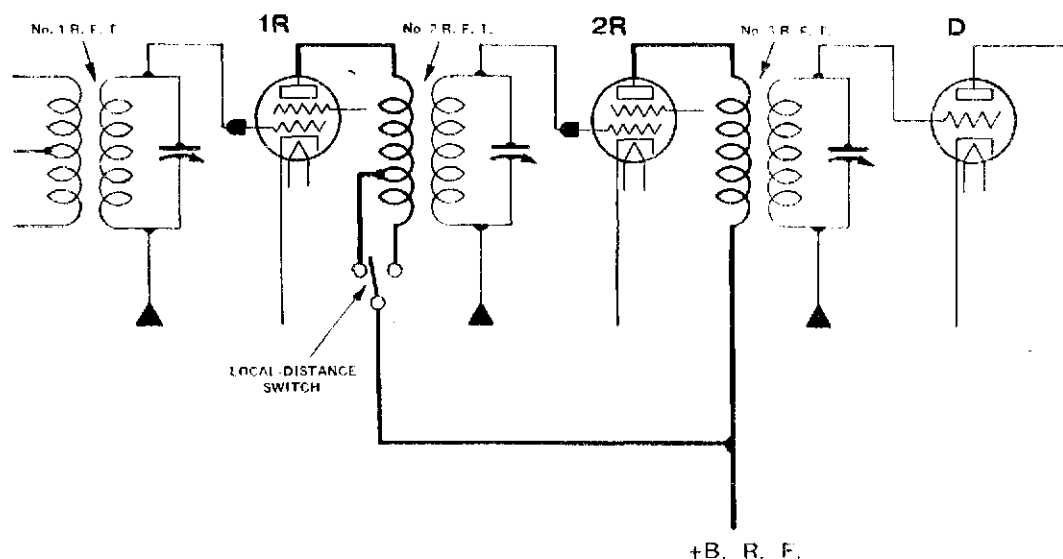

FIG. 16. ELEMENTARY CIRCUIT OF RADIO-FREQUENCY AMPLIFIER USING TWO SCREEN-GRID TUBES WITH TRANSFORMER COUPLING.

Tuned-R. F. Screen-Grid Amplifier (Continued)

The R. F. voltage across the secondary of No. 3 R. F. T. is applied to the grid and cathode of the detector tube, as described later.

(g) Prevention of Feed-Back

As mentioned previously, the screen in each R. F. amplifying tube prevents feed-back of R. F. energy from the plate (output) circuit to the grid (input) circuit.

The use of screen-grid tubes, with their high amplification properties in R. F. circuits, combined with correct engineering design of the circuit, results in an extremely sensitive and selective R. F. amplifier.

(h) Action of the Local-Distance Switch (Fig. 16)

The primary of No. 2 R. F. T. is tapped and connected to a "local-distance" switch in such a way that either a part of the primary winding, or the entire primary winding, may be connected in the plate circuit of the 1st-R. F. tube.

By using only a part of the primary, the R. F. voltage which can be built up across this section of the primary is greatly reduced.

When receiving local stations, the switch is turned anti-clockwise so that only a portion of the primary of No. 2 R. F. T. is in use.

This decreases the total R. F. amplification and reduces the possibility of overloading the detector tube when receiving local stations. It also reduces the possibility of distortion which may occur in early-type models when, in order to reduce the volume, the volume control is turned near minimum, thus making the screen-voltage almost zero. However, this condition can be brought about only if the local-distance switch is incorrectly turned to the "distance" position when receiving local or powerful stations.

In later-type models, the screen voltage cannot be reduced below a certain minimum value, thereby elimi-

nating the possibility of the distortion described in the paragraph above.

(i) Action of R. F. Amplifier with Auto-Transformer Coupling

In later-type models the R. F. tubes are coupled with auto-transformers (No. 2 and No. 3 R. F. T.) as shown in Fig. 17.

Each auto-transformer has only one winding and it serves both as the primary and secondary windings of the ordinary two-coil transformer. This winding has a tap at about the center.

A fixed "stopping" condenser is mounted on the outside of the coil form. One terminal of this condenser is connected to the center-tap of the R. F. auto-transformer. The other terminal of the stopping condenser is connected to the plate circuit of the preceding tube, as indicated in Fig. 17.

The stopping condenser permits the R. F. currents in the plate circuit of the tube to flow through the auto-transformer, but it prevents short-circuiting of the plate-voltage supply.

The +B voltage is applied to the plates of the R. F. tubes through R. F. choke coils, R. F. C. No. 1, and R. F. C. No. 2. These chokes permit the flow of steady plate current but prevent the passage of R. F. current-variations, thus forcing them to flow through the auto-transformers.

The action of the auto-transformer circuit is very similar to that of the ordinary R. F. transformer circuit.

The local-distance switch in the auto-transformer coupled R. F. amplifier is arranged differently in order to secure a greater step-down in output volume when switching from the distance to the local position. The step-down of output volume in this case is intentionally designed to be much greater than in the early models.

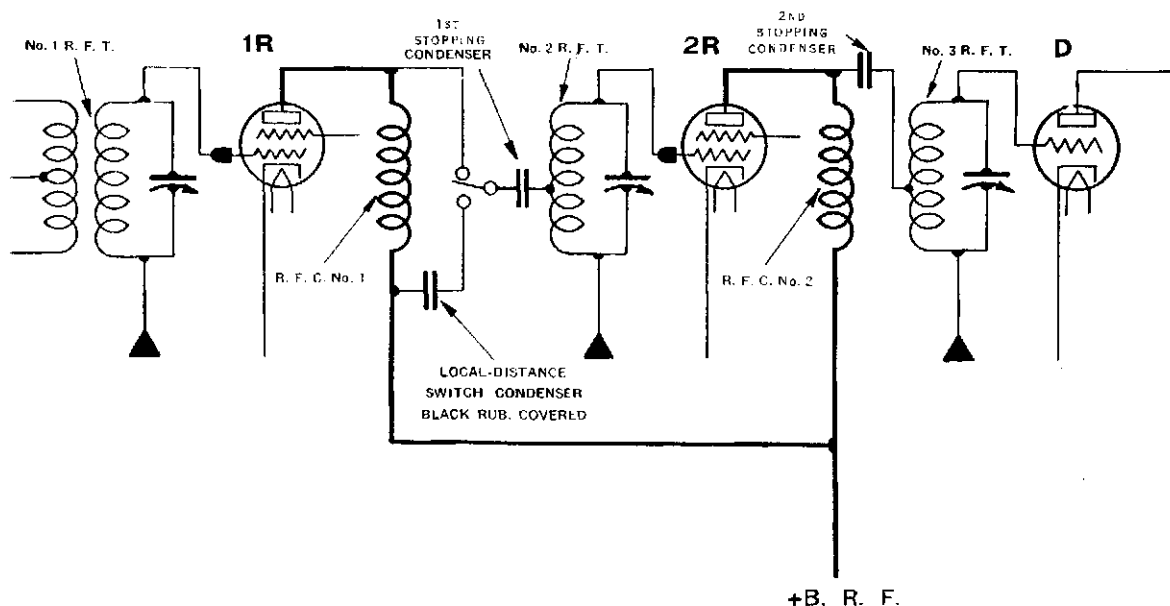

FIG. 17. ELEMENTARY CIRCUIT OF TWO-STAGE SCREEN-GRID RADIO-FREQUENCY AMPLIFIER USING AUTO-TRANSFORMER COUPLING.

Tuned-R. F. Screen-Grid Amplifier (Continued)

The connections of the local-distance switch in the auto-transformer coupled R. F. amplifier are shown in Fig. 17.

When the arm of the switch is turned clockwise to make contact with the plate side of R. F. C. No. 1, the plate of the 1st-R. F. tube is coupled to the grid circuit of the 2nd-R. F. tube through the 1st stopping condenser. This provides maximum amplification.

When the switch is turned anti-clockwise to the "local" position, the only coupling between the 1st- and 2nd-R. F. tubes is that provided by the slight capacity between the plate lead from the 1st-R. F. tube, and the

lead from the 1st stopping condenser, as both of these leads run to the switch.

The local-distance-switch condenser (formed from two pieces of wire twisted together and covered with soft black rubber tubing) has a capacity approximately equal to that between the plate and screen electrodes and leads of the 1st-R. F. tube.

The local-distance switch condenser acts as a substitute for the plate-screen capacity of the 1st-R. F. tube when the switch is turned from the "distance" to the "local" position. This prevents detuning of the grid circuit of the 2nd-R. F. tube.

C. THE DETECTOR CIRCUIT

A greatly magnified reproduction of the received broadcast energy is delivered by the R. F. amplifier to the grid circuit of the detector tube.

This amplified energy, as previously described, consists of an R. F. alternating voltage which, of course, has positive and negative half cycles.

Each side (positive and negative) of the alternations is modulated, or varied in intensity, at an audio-frequency rate.

(This audio-frequency modulation corresponds to the sound waves of voice or music at the transmitter.)

It is the function of the detector tube to suppress the effects of one side of the R. F. alternations, and allow the A. F. modulation of the remaining side to produce A. F. current variations in the detector plate circuit.

The effects of either the negative or the positive side of the applied R. F. alternations may be suppressed.

There are two main types of three-element vacuum-tube detector circuits which are used to obtain the above results:

(a) First, the "grid detection" method, using a grid condenser and leak, as shown in Fig. 18. This method is used in Model 61 and 67. With this circuit, the plate current varies below normal when a signal is being re-

ceived, indicating that the grid voltage becomes more negative.

The exact explanation of the action of this circuit is rather involved. For our purposes, it is sufficient to know that the grid, being isolated by the grid condenser from direct connection to the cathode circuit (except through the grid leak), accumulates a negative charge when the R. F. voltage variations are applied to the grid condenser. This charge leaks off, at the modulating frequency, through the grid leak, which has a resistance of several million ohms.

The result is that the electron flow between plate and cathode decreases below normal at a radio-frequency rate, and the amount of this decrease varies at an audio-frequency rate, corresponding to the modulation of one side of the applied R. F. voltage alternations in the grid circuit.

The A. F. variation of plate-circuit current sets up an A. F. voltage across the primary of No. 1 A. F. T., which has a high effective resistance (impedance, or opposition) to A. F. current variations. The A. F. voltage across the primary induces an A. F. voltage across the secondary; this A. F. voltage is fed into the audio-frequency amplifier.

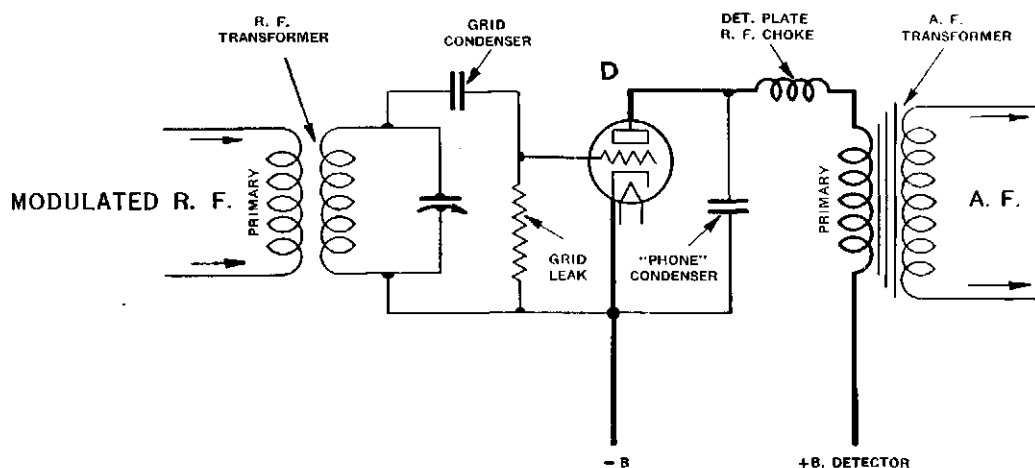

FIG. 18. CIRCUIT OF THREE-ELEMENT VACUUM-TUBE DETECTOR USING THE GRID-CONDENSER—GRID-LEAK METHOD OF DETECTION.

The Detector Circuit (Continued)

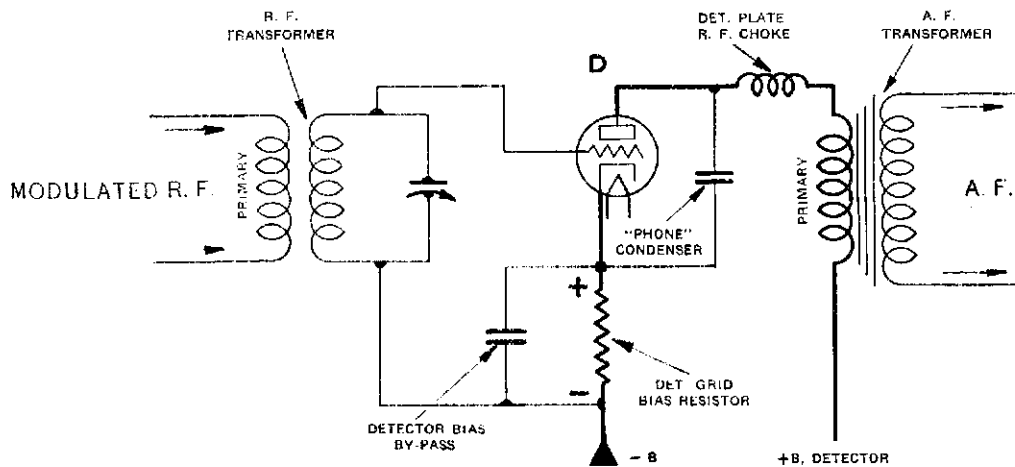

FIG. 19. CIRCUIT OF THREE-ELEMENT DETECTOR USING NEGATIVE BIAS ON GRID.

In the A.C.-operated screen-grid models, resistance coupling is used between the detector plate circuit and the 1st-A.F. grid circuit. However, for the sake of easy comparison with Fig. 18, A.F. transformer coupling is shown above.

(b) The second method of detection with a three-element vacuum-tube circuit is termed "plate detection," and it is employed in the A.C.-operated screen-grid models.

In this circuit, Fig. 19, the grid of the tube is maintained at a relatively large negative voltage with respect to the cathode.

Because of this negative grid voltage, the plate-circuit current is extremely low.

When the modulated R.F. voltage supplied by the R.F. amplifier is impressed on the grid bias voltage, it makes the grid voltage alternately more negative and less negative than its normal bias value.

When the grid is more negative than its normal bias, the plate current, being already very low, cannot decrease appreciably.

However, when the grid voltage is less negative than its normal bias, it produces an increase in the plate-circuit current.

In other words, the effect of the negative half-cycles of the applied R.F. voltage alternations is suppressed, and the A.F. modulation of the positive half-cycles produces an A.F. variation in the plate-circuit current.

This A.F. current variation sets up an A.F. voltage across the primary of No. 1 A.F.T. The A.F. output of this transformer feeds the audio amplifier.

(This method of detection may also be described as operating the detector tube on the "bottom bend" of its plate-current-grid-voltage characteristic, at which point an increase of negative voltage on the grid does not decrease the plate current, but a decrease of negative voltage does increase the plate current.)

With this method of detection, the plate-circuit current increases when a signal is received.

D. THE AUDIO-FREQUENCY AMPLIFIER

As its name indicates, the audio-frequency amplifier is used to amplify the audio-frequency (A.F.) output of the detector tube.

The audio amplifier must be so designed that it will not alter the form or shape of the audio-frequency energy delivered to it by the detector tube. If any such alteration does occur, the reproduction will be distorted from its original form.

The amplification must be the same at all audio frequencies, otherwise some frequencies will be submerged, and other frequencies will be exaggerated, resulting in unnatural reproduction.

All Atwater Kent screen-grid receivers (prior to the introduction of the pentode tube in Model 84) have two stages of audio-frequency amplification. The 2nd, or output stage, has two tubes, which make available more than twice the output power of a single tube.

These audio amplifiers, in conjunction with the screen-

grid R.F. tubes, have ample reserve power, which, as in the case of a high-powered automobile, is seldom used to its maximum capacity.

The audio-frequency amplifier in the A.C.-operated models is somewhat different from that used in Model 61 and 67. The latter two models are designed to have greater amplification for each audio stage in order to compensate for the necessarily lower plate voltages.

The principal difference between the two audio amplifying systems is in the method of coupling the detector to the 1st-A.F. tube.

In the battery-operated and direct-current receivers, Model 61 and 67, an audio-frequency transformer is used to couple the detector and 1st-A.F. tubes.

In the A.C.-operated models, "resistance coupling" is used between the detector and 1st-A.F. tubes.

A brief explanation of the action of these two methods of coupling is given on the next page.

The Audio-Frequency Amplifier (Continued)

(a) Transformer-Coupled 1st-Audio

In Fig. 19, the A. F. voltage which is set up across the primary of No. 1 A. F. T., as a result of A. F. variations in the detector plate-circuit current, induce a corresponding A. F. voltage across the secondary of No. 1 A. F. T. The voltage across the secondary is greater than the voltage across the primary because the transformer has a step-up ratio, that is, more turns in the secondary than in the primary.

The A. F. voltage across the secondary of No. 1 A. F. T. is impressed on the normal grid bias voltage of the 1st-A. F. tube.

As a result, the grid voltage becomes alternately less negative and more negative than its normal bias value, thus producing corresponding variations in the 1st-A. F. plate-circuit current equally above and below its normal value.

The current variations in the 1st-A. F. plate circuit are exactly similar to the A. F. current variations in the detector plate circuit, but of much greater amplitude or power owing to the amplification provided by No. 1 A. F. T. and the 1st-A. F. tube.

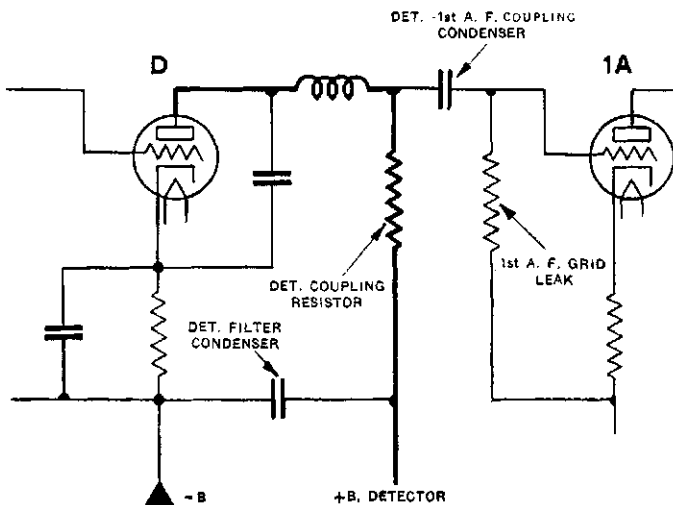

FIG. 20. DIAGRAM SHOWING RESISTANCE COUPLING BETWEEN DETECTOR AND 1ST-A. F. TUBES.

(b) Resistance-Coupled 1st-Audio

Fig. 20 shows resistance coupling between the detector and 1st-A. F. tubes.

In this circuit the grid of the 1st-A. F. tube is connected to the negative end of a bias resistor in its cathode circuit through a grid leak of about one-tenth of a megohm. This leak provides a path for the grid bias voltage to reach the grid, and it also prevents the accumulation of a negative charge on the grid.

The A. F. current variations in the detector plate circuit set up an A. F. voltage across the detector-coupling resistor. This A. F. voltage is fed to the grid of the 1st-A. F. tube through a fixed condenser of large capacity which has low effective resistance to A. F. current variations, but very high effective resistance to D. C.

The A. F. voltage which is fed through the coupling condenser is superimposed on the normal grid bias voltage of the 1st-A. F. tube.

As a result, the grid voltage becomes alternately less negative and more negative than its normal bias value, thus producing corresponding variations in the 1st-A. F. plate-circuit current equally above and below its normal value.

The current variations in the 1st-A. F. plate circuit are exactly similar to the A. F. current variations in the detector plate circuit, but of greater amplitude, owing to the amplification provided by the 1st-A. F. tube.

(c) The "Double-Audio" Output Stage

Except for the method of securing grid, plate, and filament voltages, the action of the double-audio output stage shown in Fig. 26 on Page 27 is typical of all double-audio output stages in Atwater Kent screen-grid receivers.

The A. F. variations in the plate-circuit current of the 1st-A. F. tube produce an A. F. voltage across the primary of the input A. F. transformer. This induces a corresponding A. F. voltage across the secondary.

A tap connection is made to the center of the secondary of the input A. F. transformer. This tap is connected to the negative end of a bias voltage. The positive end of the bias is connected to the filament circuit of the 2nd-A. F. tubes, thus maintaining the grids of both tubes at a negative voltage with respect to their filaments.

The plate of each 2nd-A. F. tube is connected to the primary of an output A. F. transformer. A center-tap on this primary is connected to the positive terminal of a high-voltage D. C. supply.

The A. F. voltage developed across each half of the secondary of the input A. F. transformer is superimposed on its normal grid bias voltage.

This makes the grid voltage of each tube alternately less negative and more negative than its normal bias voltage, and produces corresponding variations in the plate-circuit current of each tube equally above and below its normal value.

When the grid voltage of one 2nd-A. F. tube is becoming more negative, the grid voltage of the other 2nd-A. F. tube is becoming less negative; consequently, the plate-circuit current of one decreases as the plate-circuit current of the other increases.

This produces a co-operating A. F. variation of current through the primary of the output A. F. transformer. As the primary has a high opposition to A. F. current variations, an A. F. voltage is set up across the primary.

This A. F. voltage across the primary of the output transformer is similar in form to the A. F. voltage across the primary of the input A. F. transformer, but of much greater power owing to the amplification provided by the 2nd-A. F. tubes.

The advantages of the double-audio output stage are briefly as follows:

1. The two tubes acting together provide more than twice the available undistorted output power of one tube of the same type.
2. The double-audio output tubes balance out any variation or ripple in their plate-voltage or grid-voltage supply, thus reducing hum. In order to secure this balanced condition it is necessary to use matched tubes.

The Audio-Frequency Amplifier (Continued)

E. The Electro-Dynamic Speaker.

The Atwater Kent electro-dynamic speaker, which is used to convert the electrical output of the audio-frequency amplifier into audible energy, or sound waves, has a practically uniform response to all audio frequencies.

The A. F. voltage across the primary of the output transformer induces an A. F. voltage of much smaller value in the secondary (owing to the step-down ratio of this transformer). This low A. F. voltage is fed into the voice coil of the speaker. The voice coil has low resistance, consequently on a strong signal the A. F. current in the voice coil circuit is comparatively high. The magnetic field produced by flow of current through the voice coil reacts against the constant powerful field of the electro magnet, thus producing motion of the voice coil.

THE POWER SUPPLY SYSTEM IN A. C.-OPERATED MODELS

The power supply system must take the 110-volt A. C. (alternating-current) and from it produce high-voltage D. C. (direct-current) for the plate and screen circuits, low-voltage direct-current for the grid circuits, and low-voltage alternating-current for the filament circuits. This is done in this way:

A. The Power Transformer

The 110-volt A. C. supply is fed into the primary of a power transformer (see Fig. 21). There are four secondary windings on this transformer:

(a) The 2nd-A. F. filament winding provides 2.5 volts A. C. for the filaments of the 2nd-A. F. tubes.

F. A Summary of the Action of the Receiving Circuit

We have now studied the action of the various sections of the receiving circuit, and before beginning to study the power supply system, it may be helpful briefly to review what we have read.

1. The R. F. amplifier selects the frequency of one broadcast station, excludes all other stations, and amplifies, without distortion, the energy received from the desired station.

2. The detector circuit rectifies the amplified R. F. energy and allows the modulation of this energy to affect the audio-frequency amplifier.

3. The audio-frequency amplifier increases the power of the audio-frequency energy delivered by the detector tube.

4. The electro-dynamic speaker converts the electrical output of the audio-frequency amplifier into audible energy or sound waves.

(b) The R. F.—detector—1st-A. F. filament winding supplies 2.5 volts A.C. for the filaments of the R. F.—detector—1st-A. F. tubes.

(c) The rectifier filament winding supplies 5 volts A. C. for the filament of the rectifier tube.

(d) The high-voltage winding provides about 350 volts A. C. to each plate of the rectifier tube (measuring from the center tap of the high-voltage winding to each plate of the rectifier).

These values of secondary voltage are obtained by designing the transformer in accordance with a fundamental electrical principle that the ratio of primary voltage to secondary voltage is equal to the ratio of primary turns to secondary turns.

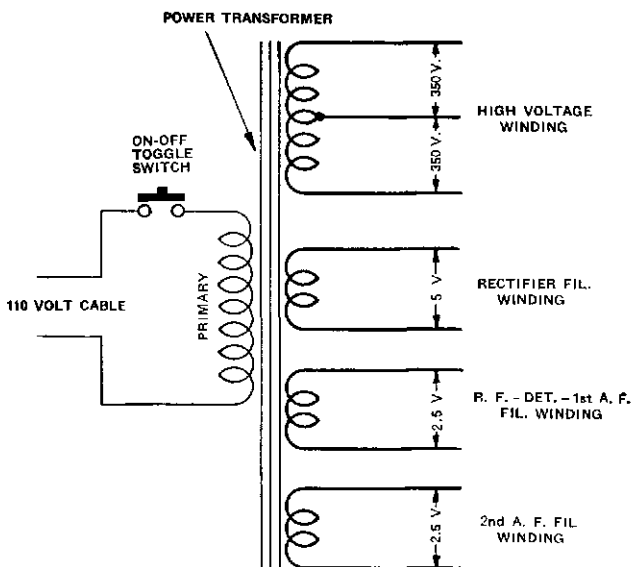

FIG. 21. THE POWER TRANSFORMER TAKES 110 VOLTS A. C. AND TRANSFORMS IT INTO HIGHER AND LOWER VALUES OF ALTERNATING CURRENT AS INDICATED ABOVE (EARLY MODEL 55).

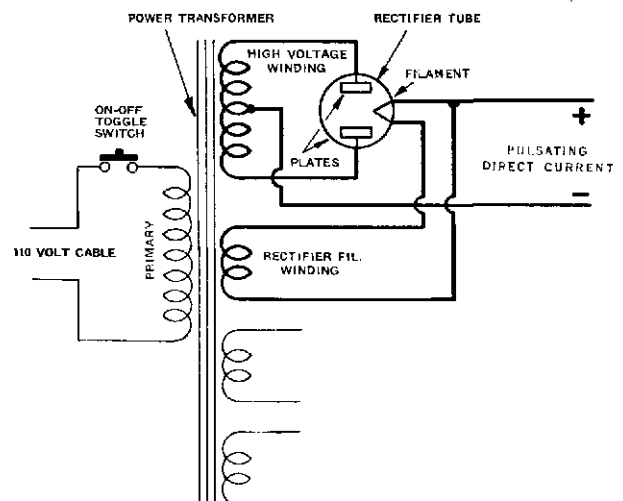

FIG. 22. THE HIGH-VOLTAGE A. C. IS CONVERTED INTO PULSATING D. C. BY A "FULL-WAVE" RECTIFYING TUBE, AS SHOWN ABOVE.

The Power Supply System (Continued)

B. Rectifying and Filtering the High-Voltage A. C.

The high-voltage A. C. must be converted into high-voltage D. C. before it can be used to supply the plate, screen, and grid circuits of the receiving tubes. This conversion is accomplished by rectifying the high-voltage A. C. (through use of a "full-wave" rectifying tube), as shown in Fig. 22, and feeding the resultant pulsating D. C. into a filter circuit which delivers a smooth high-voltage direct-current output, similar to that provided by "B" batteries.

The filter circuit, Fig. 23, contains audio-frequency chokes and large filter condensers.

The filter chokes, which are connected in series with the line, offer a high opposition to the alternating current component of the pulsating D. C. which is supplied by the rectifier tube. The chokes therefore tend to prevent passage of the pulsations in current, but offer only slight resistance to the direct-current portion of the current.

The filter condensers, connected across the supply lines, have low effective resistance to the A. C. component of the pulsating D. C. which is supplied by the rectifier tube. The filter condensers therefore tend to short-circuit the pulsations in the current, but as the condensers have a very high opposition to D. C., they do not affect the D. C. component of the pulsating D. C. supply.

The result of the action of the filter circuit is that the pulsations (in the direct-current furnished by the rectifier tube) are smoothed out, and after passing through the filter circuit, the current is practically pure D. C., and hence will not introduce any hum in the receiver. See Fig. 27 on Page 28.

(The detector and 1st-A. F. plate circuits have separate additional audio-frequency filters, comprising a filter resistor and filter condenser, which serve to prevent undesired reaction between the plate currents, which reaction has a tendency to occur owing to the coupling provided by the common supply.)

C. DISTRIBUTING THE HIGH-VOLTAGE D. C. TO MEET THE REQUIREMENTS OF THE RECEIVING TUBES

After the high-voltage A. C. has been rectified and filtered into pure D. C., it is distributed among the tubes in such a way as to meet the voltage requirements of each tube.

(a) Feeding the Plate Circuits

In order to understand how the correct voltages are applied to each tube, it is helpful to study the circuit of early Model 55 in Fig 15-A, and note that the negative line of the filter circuit goes through the speaker field coil to the chassis. Also, by tracing out the plate circuit of each tube, and the screen circuit of each R. F. tube, it will be found that these are all fed from the positive line of the filter circuit.

After entering the plate or screen circuit, how does the current get back to the negative side of the filter circuit?

The return path for each plate and screen circuit is across the electron-stream between plate and cathode, or screen and cathode, then through the bias resistor for that tube and back to the negative line (chassis) of the filter circuit.

(In the 2nd-A. F. tubes, the return path of the plate circuit is somewhat different, as will be described later.)

(b) How Grid Bias is Obtained

The plate current of each tube, or the plate and screen current of each R. F. tube, flows through the bias resistor.

This current produces a voltage across the bias resistor and, if the grid return of the tube is connected to the negative end of the resistor, the grid will be held at a negative voltage with respect to the cathode.

This voltage (across the bias resistor) constitutes the grid bias for the particular tube. The value of the bias voltage is governed by the resistance of the bias resistor, and by the value of the total current flowing through the bias resistor.

This may be understood more readily by studying Fig. 24 which shows the complete plate circuit of an R. F. tube. Here, as indicated by arrows, the current flows from the positive side of the filter circuit through the primary of the R. F. transformer, across the plate-

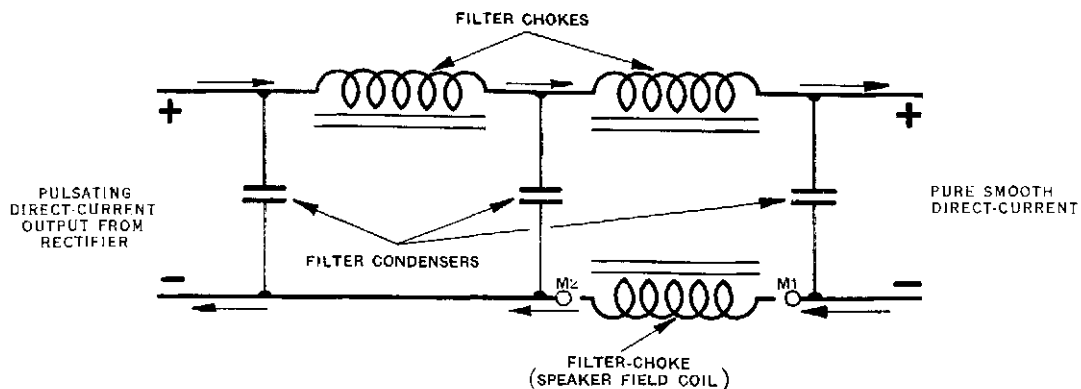

FIG. 23. THE PULSATING D. C. DELIVERED BY THE RECTIFIER CIRCUIT IS FILTERED INTO SMOOTH D. C. BY A COMBINATION OF AUDIO-FREQUENCY CHOKES AND LARGE FILTER CONDENSERS. THE FILTER CIRCUIT IS SHOWN ABOVE. (Arrows indicate direction of current flow.)

The Power Supply System (Continued)

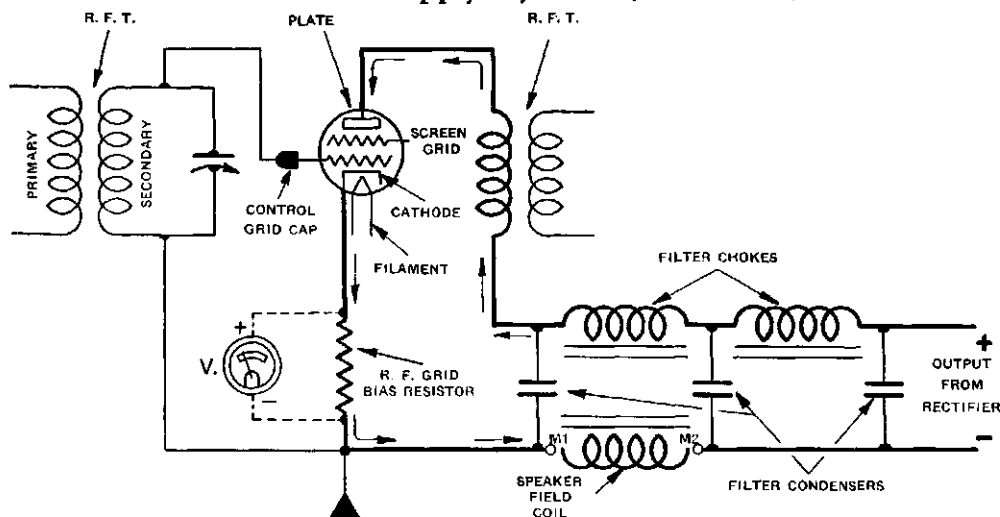

FIG. 24. GRID BIAS MAY BE SECURED BY VOLTAGE DROP ACROSS A BIAS RESISTOR CONNECTED BETWEEN CATHODE AND -B.

The plate circuit current, flowing through the bias resistor, as indicated by arrows, causes a voltage drop across the resistor, thus making the cathode positive with respect to the grid-return lead, and therefore making the grid negative with respect to the cathode.

cathode electron path, through the bias resistor, and back to the negative side of the filter circuit.

The grid-return of the tube is through the secondary of the left-hand R. F. T. and thence to the negative end of the bias resistor. The voltage across the bias resistor (measured with a high-resistance D. C. voltmeter "V"), which is produced by the flow of plate and screen current, serves to make the grid negative with respect to the cathode.

(c) Measuring the Grid Bias

In actual measurement of the grid bias, we recommend measuring from the grid of the tube to the

cathode, as shown in Fig. 25, in order to check the continuity of the grid circuit and measure the bias in one operation. However, in doing this, if the grid return path or the bias resistor has a high resistance in proportion to the resistance of the voltmeter, the measured voltage will be less than the voltage across the bias resistor. This is true when measuring the 1st-A. F. and the detector grid voltages in the A. C.-operated screen-grid models. In the voltage tables for these models we give the detector and 1st-A. F. grid voltages as measured from grid to cathode with the 0-50 scale of a one-thousand-ohm-per-volt meter. The actual normal bias voltage is higher.

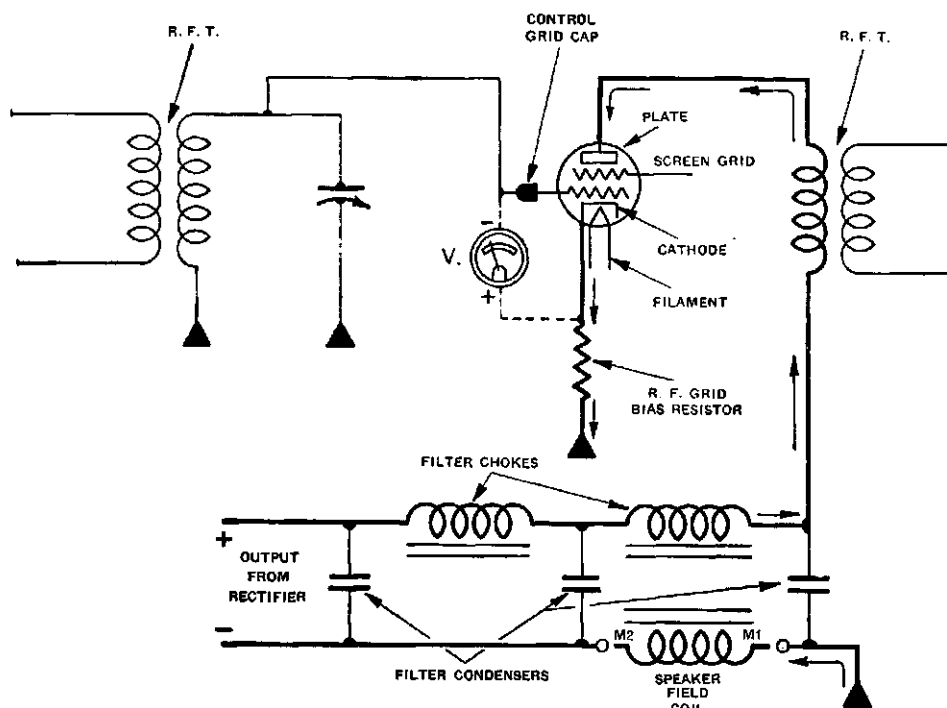

FIG. 25. THIS IS THE SAME CIRCUIT AS FIG. 24, BUT IT APPEARS DIFFERENT BECAUSE THE GRID-RETURN, CATHODE, AND -B, CHASSIS CONNECTIONS ARE SHOWN SEPARATELY.

The Power Supply System (Continued)

(d) Tracing the Bias Circuit

In the complete diagram of early Model 55, Fig. 15-A, it is not as easy to trace out the complete plate-circuit path of each tube, as it is in Fig. 24. This is caused by the fact that in a desire to make the complete diagram (Fig. 15-A) follow the actual wiring of the set, so it will be most helpful in service work, we have shown separate chassis connections for the grid circuits, cathode circuits, and negative end of the main filter circuit.

This may be appreciated by comparing Figs. 24 and 25, which are identically the same electrically, but appear different because in Fig. 24 there is one chassis connection for all the circuits, while in Fig. 25 the chassis connections are shown separately.

(e) How Grid Bias is Obtained for 2nd-A. F. Tubes

The grid bias for the 2nd-A. F. tubes could be secured by connecting the filaments of these tubes to the negative end of the filter circuit through a suitable resistor, and connecting the grid return (center-tap of the secondary of the 2nd-A. F. input transformer) to the negative end of this resistor.

However, as the 2nd-A. F. bias voltage must be about 45 volts for the 245 tubes, and about 80 volts for the 250 tubes, it would not be economical to use this high voltage (which is subtracted from the total voltage available for the plates of the 2nd-A. F. tubes) merely for biasing the 2nd-A. F. tubes.

Therefore, a different method is used, as shown in Fig. 26. Here the speaker field coil is used as a filter choke and is connected in the negative line of the filter circuit. The field coil has resistance, and, as the D. C.

currents of all plate and screen circuits flow through the negative line of the filter circuit, and therefore through the field coil, there is a D. C. voltage across this coil.

In Model 66, the voltage across the field coil is about 80 volts. Therefore, by connecting the filament circuit of the 2nd-A. F. tubes to the positive side (chassis) of the field coil, and connecting the grid return of the 2nd-A. F. tubes to the negative end of the coil, the grids of the 2nd-A. F. tubes are maintained at 80 volts negative with respect to their filaments.

The connection to the filament circuit is made through the center-tap of a filament-shunt resistor for the reason explained previously.

In the A. C.-operated models which employ 245 and 171-A tubes, requiring a grid bias of about 45 volts, a similar biasing system is used, but instead of using the entire voltage across the field coil, a potentiometer arrangement of resistors is connected across the field coil so that the correct portion of the total voltage is available for grid bias of the 2nd-A. F. tubes. This is shown in the diagram of early Model 55, Fig. 15-A, and also in Fig. 27.

Because of this careful engineering design, the speaker field coil serves three purposes:

1. It acts as a filter choke, thus helping to smooth out the plate-voltage supply.
2. The D. C. voltage across the field coil is used in whole or in part to bias the grids of the 2nd-A. F. tubes.
3. The total plate current of the tubes, flowing through the field coil, produces a strong magnetic field in the circular air-gap of the speaker magnet.

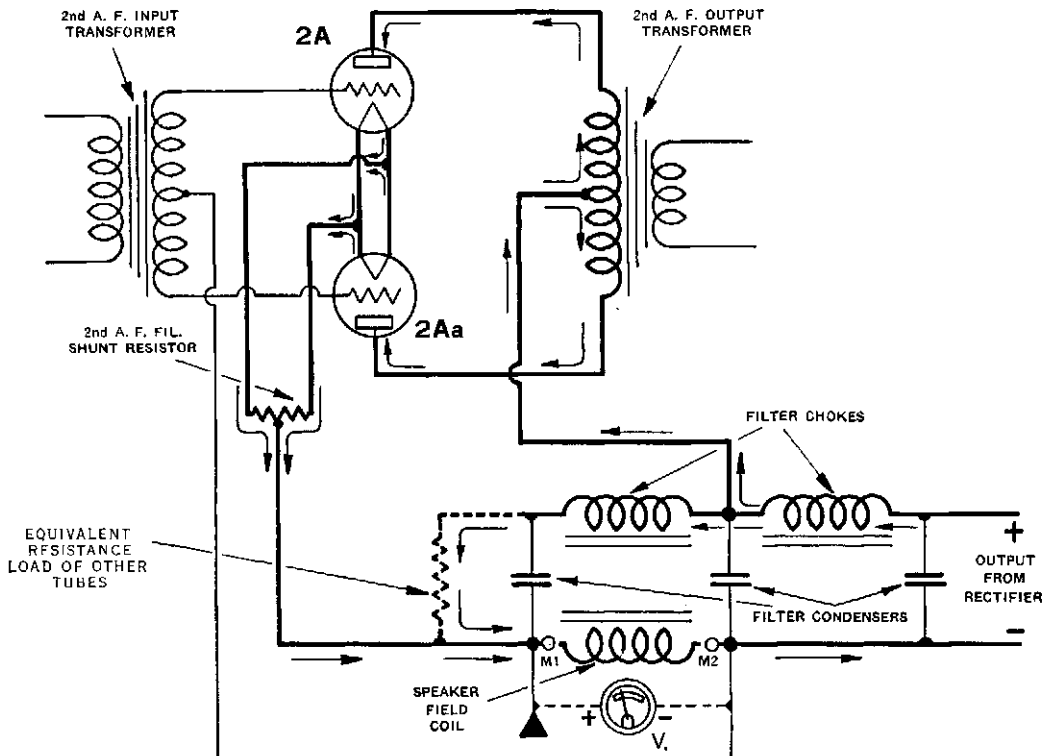

FIG. 26. THE 2ND-A. F. BIAS VOLTAGE IN MODEL 66 IS OBTAINED BY THE DROP ACROSS THE SPEAKER-FIELD COIL IN THE NEGATIVE SIDE OF THE FILTER CIRCUIT.

The filament circuit of the 2nd-A. F. tubes is connected to the positive side (chassis) of the field coil, and the grid-return (center-tap of the secondary of the input A. F. transformer) is connected to the negative side of the field coil. The bias voltage is measured with a high-resistance D. C. voltmeter "V."

The above diagram does not show the grid-filter resistor and condenser which are used in Model 66.

The Power Supply System (Continued)

(f) How the Screen-Grid Voltage is Controlled

The sensitivity of the R. F. amplifier, and consequently the output volume of the set, may be controlled by regulating the screen voltage.

When the screen voltage is adjusted to its maximum value, the R. F. amplifier has greatest sensitivity and amplification. Both of these factors decrease as the screen voltage is decreased.

For engineering and production reasons the circuit arrangement for securing the correct screen voltage

varies in different models, and also in different types of the same model. The arrangement used in Model 55 and 55-C is shown in Figs. 28 and 29.

(g) The Complete D. C. Distributing System

Having now reviewed the rectifying and filtering circuit, and having described how the plate, grid, and screen voltages are obtained, it will prove helpful to study Fig. 27, which shows the complete D. C. distributing system for later Model 55.

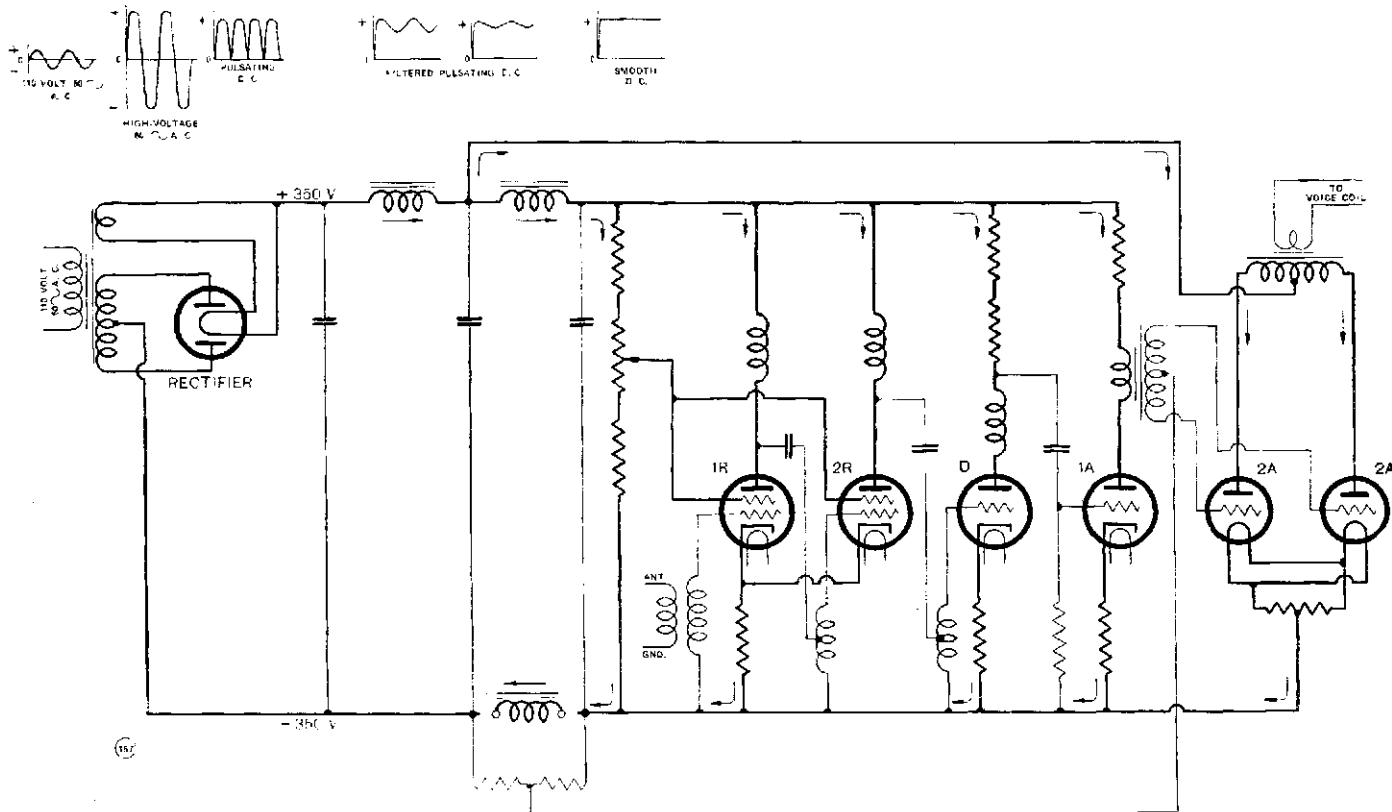

FIG. 27. D. C. DISTRIBUTING SYSTEM OF LATER 55 AND 55-C.

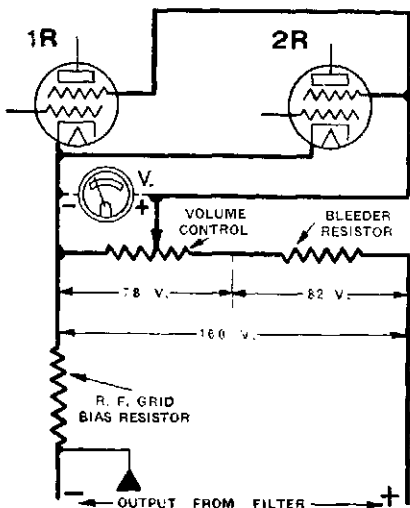

FIG. 28. IN EARLY MODEL 55 AND 55-C, THE SCREEN VOLTAGE IS ADJUSTABLE FROM ZERO TO ABOUT 78 VOLTS, AS SHOWN AT LEFT.

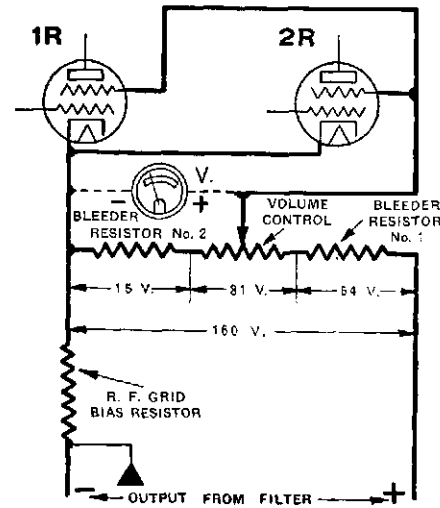

FIG. 29. IN LATER MODEL 55 AND 55-C, THE SCREEN VOLTAGE IS ADJUSTABLE FROM ABOUT 15 TO 96 VOLTS, AS SHOWN AT RIGHT.

The screen voltage is measured with a high-resistance D. C. voltmeter "V."

IMPORTANT FACTS THE ATWATER KENT DEALER SHOULD KNOW

1. Replacing R. F. Transformers.

Atwater Kent dealers should keep constantly in mind this fact:

Single R. F. transformers are not sold separately.

When a single R. F. transformer in a set becomes burned out or damaged, it is necessary to replace the entire R. F. transformer group or assembly. This is due to the fact that these coils are matched in groups at the factory and sold from the factory in complete groups only.

If you do not have a replacement group in stock, return the group containing the damaged coil or coils to your distributor who will exchange it for a new group and charge you only for the coil or coils needing replacement. Refer to parts list for prices of replacements on each type of set.

2. Replacing Coils in Magnetic Speakers.

Coils for magnetic (horn or cone) type speakers are not sold separately.

This is due to the fact that when a new coil is installed it is necessary to remagnetize the poles which can only be done at the factory. When you have a speaker unit with burned out coil, return the unit to the distributor who will replace it and charge you only for the burned out coil plus a small labor charge.

3. Replacing Carbon-Type Volume Controls.

Parts for carbon-type volume controls (used in later screen-grid sets) are not sold separately.

Owing to the fact that special tools are required for assembling carbon-type volume controls, parts for this type control are not furnished separately. When one of these controls develops trouble, return it to your distributor for replacement at a charge for labor and material involved.

4. Operating 25-Cycle Sets on 60-Cycle Current.

A receiver designed for 25-cycle operation will function satisfactorily on 25-, 40- or 60-cycle current. However, a 60-cycle set must not be operated on 25-cycle or 40-cycle current, otherwise overheating and damage will result.

5. Converting D. C. Sets to A. C. and Vice-Versa.

The dealer may frequently be confronted with the question as to the possibility of changing over a D. C. set for use on A. C. or vice-versa. The cost of making any such change would be entirely prohibitive, consequently the only solution in a case of this kind (where the current is changed or customer moves to a location where current is different) is a trade-in for a model using the current called for. If the dealer can not handle the exchange himself he should take the matter up with his distributor. One exception to this may be mentioned in the case of an A. C. set which may be operated from a D. C. line by using a small motor generator—these can be purchased for as low as \$50.00.

6. Operating a Radio on a 32-volt D. C. Lighting System.

Probably the most economical method of utilizing the 32-volt farm lighting system for radio is to use a standard A. C.-type receiver in connection with a small motor generator, designed to operate on 32-volts D. C. and deliver 110 volts A. C. There are several such generators available at reasonable prices.

A 6-volt battery-type receiver may be operated on 32 volts by using a suitable resistor (several commercial types are available) in series with the line, to reduce the voltage to that required for the filaments of the tubes. Resistors equipped with automatic cut-out to prevent overload are available.

The 32-volt system cannot be utilized to supply the plate or "B" voltage to a battery-type set. This must be supplied by dry "B" batteries. Storage "B" batteries which can be recharged (in sections) from the 32-volt system are also available.

7. Use of the Electro-Dynamic Speaker on Early-Type Sets.

We do not advise attempting to use an electro-dynamic speaker with our earlier type sets designed primarily for the use of a magnetic speaker. The dealer is advised to endeavor to sell the customer a complete new receiver in such cases, explaining to the customer the advantage of having an outfit in which the set and speaker were designed by the factory, to work together to give maximum performance.

8. Use of Screen-Grid Tubes in Early Models.

It is frequently asked if it is practical or advantageous to use screen-grid tubes in the early type electric or battery receivers which were manufactured before the screen-grid tubes were developed.

The answer to this question is that a receiver must be especially designed in order to use screen-grid tubes; owing to the peculiar nature of these tubes and their extreme sensitivity, they will not give best results in an ordinary tuned R. F. circuit of the early type. It can therefore be readily seen that it would be impractical to re-design an old set to permit using these tubes, owing to the expense and complications involved.

Here again the dealer is advised to urge the customer to trade-in his old set as part payment on an up-to-date model.

9. Adding Extra Speakers or Headphones to Various Atwater Kent Receivers.

Very often it is desired to use one or more additional speakers or headphones in other rooms, etc., the extra speakers being connected so that they can be switched on or off independently of the regular or original speaker. The method used for making connections of the additional speakers depends upon the type of set. An outline follows:

(1) *Magnetic Sets.*

One or several additional magnetic or inductor-type JB speakers or headphones may be used by simply connecting in parallel with the original speaker; that is, simply run leads from the output or speaker posts of the set to the additional speakers at their locations.

If more than two or three additional speakers are used a series-parallel connection is advisable. Headphones may be used in place of speakers if a suitable resistor is connected in series with one lead to regulate the volume.

A single-pole—single-throw switch in one lead to each extra speaker will permit it to be turned on at will.

Important Facts (Continued)

(2) *Early Electro-Dynamic Sets, Model 43, 46, 47 and 53.*

A small number of additional magnetic or inductor-type JB speakers or headphones may be used by making connection to the two terminals at the right-hand end of the rear row of terminals on top of the power unit. Simply solder two leads to these two terminals and bring the leads out through cover of set to the common leads of the additional speakers.

(3) *Screen-Grid Sets, Model 55, 60 or 66.*

In cases where more than one additional speaker or headphone are desired, we suggest the use of the special tapped output transformer (No. 15930), which we designed for this purpose. This transformer is simply substituted for the regular output transformer in the set and connection of the group of additional speakers made to whichever two of the five taps on the special transformer give the best results.

With this arrangement Model 55, 60 or 66 will handle up to 15 or 20 additional magnetic or inductor-type JB speakers satisfactorily.

We do not advise the use of additional electro-dynamic speakers, owing to the expense and difficulty of supplying direct current for the fields.

Where only one additional speaker or headphone is desired, we suggest an arrangement as shown in the illustration, which consists of tapping off the voice coil leads of the speaker cable, with a step-up transformer and connecting the extra speaker across half the

secondary winding of this transformer. The use of switches so that either the regular or extra speaker may be cut out at will, is shown.

(4) *Model 67 Screen-Grid Battery-Type Receiver and Model 61 D. C. Receiver.*

A few extra magnetic or inductor-type JB speakers or sets of headphones may be used with these sets by running leads to them from the plates of the output tubes (171A) in the set.

(5) *1931 Models: Type L, F and P Chassis.*

The only satisfactory method of connecting additional magnetic or inductor-type JB speakers or headphones to these sets is by the use of our special output transformer, No. 17790, which is to be substituted for the regular transformer attached to the type N speaker. This special transformer is provided with 5 taps to permit best results with different numbers of speakers, up to 15 or 20 being practical. A connection is also provided in the transformer whereby the electro-dynamic speaker on the set may be shut off if desired.

(6) *1931 Models: Type D (D. C.) and Q (battery) Chassis.*

A few extra speakers or headphones may be used with these sets by making connection to the plates of the output (171A) tubes.

(7) *Model 84.*

No provision has been made for the use of additional speakers with this model; extra electro-dynamic speakers for this set are not sold separately.

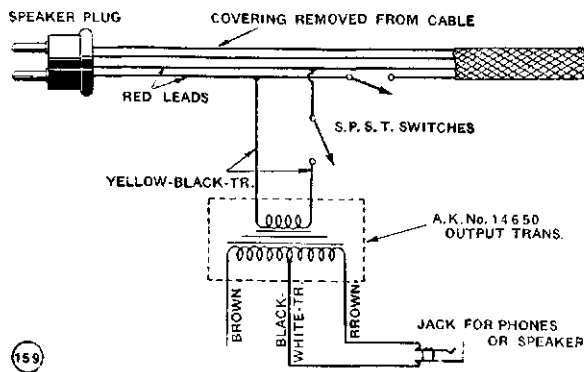

FIG. 32. CIRCUIT ARRANGEMENT FOR ADDING AN EXTRA SPEAKER TO MODEL 55, 60 OR 66.

SERVICE NOTES FOR SCREEN-GRID RECEIVERS

A. Replacing R. F. Transformers and Variable Condensers:

As in the other Atwater Kent single-dial receivers, if one R. F. transformer is defective or damaged, the entire group must be replaced. Likewise if one variable condenser is defective, all of the variable condensers must be replaced. Single R. F. coils or variable condensers are not furnished.

B. Replacing Eyeletted Parts:

The tube sockets, identifying plates and tube-shield bases are fastened with eyelets to the base-plate, and several parts are eyeletted to the main panel, but if any of these parts requires replacement, it may be removed by cutting out the eyelets, and the replacement part may then be mounted in position with short 6/32 or 8/32 screws and nuts.

C. Synchronizing Condensers:

When synchronizing the condensers, connect the oscillator pick-up lead to the Short-Antenna post, and place the local-distance switch in the "distance" position.

The bottom-plate should be screwed in position when testing any of the screen-grid models for output volume, or when synchronizing the condensers. However, in order to avoid the necessity of removing and replacing this plate a number of times, it will be found more convenient to cover the top of the test bench with a sheet of tin (about 20 gauge), which should be connected to ground. This sheet of metal acts as a shield in place of the bottom-plate.

In Model 61, the chassis must not be connected to ground, so in this case the ground connection to the sheet of tin should be opened. When testing both A. C. and D. C. receivers, an on-off toggle switch may be connected in the ground lead to the tin sheet. This switch should be opened when testing the screen-grid direct-current receivers.

D. Use Top Plate:

Owing to the design of the R. F. amplifying circuit in the screen-grid receivers, it is necessary to use a top shielding-plate when synchronizing the variable condensers. In the shield for three-condenser receivers, such as Model 55, it is necessary to cut a hole in the shield over the rotor of No. 1 condenser in order to make this rotor accessible for adjustment. This hole should be about 1½ inches in diameter with its center 2¼ inches from the left edge of the shield and about 1⅜ inches from the front edge. The rotor of No. 1 condenser may then be adjusted with one finger through this hole. No. 2 condenser rotor may be adjusted by turning the control knob, and No. 3 rotor may be reached from the right-hand side of the chassis.

In four-condenser screen-grid receivers, such as Model 60, a 1½ inch hole should be drilled in the shield over the rotors of No. 1, No. 3 and No. 4 condensers.

A top shield for the three-condenser type receivers, and a top shield for the four-condenser type receivers, with holes cut as mentioned above, should be available at each testing bench. These specially-drilled shields are NOT supplied from the factory.

E. Operating-Voltage Measurements:

One of the quickest methods of testing the screen-grid receivers is by measuring the voltage at each tube socket as indicated in the tables for each set. **Please note that the voltage values are approximate only.** These measurements must be made while the set is in operation, using either a commercial set-analyzer, with adapters which fit into the tube sockets, or using separate A. C. and D. C. voltmeters, making connection to the tube socket-contacts under the base plate. All of the socket-contacts may be exposed by inverting the set and removing the flat bottom-plate.

F. Continuity Testing:

Separate parts may be tested for continuity with a voltmeter and battery in the usual way. If there is any doubt as to whether a part is shorted, grounded, or open, it is advisable to remove all connecting leads to that part and test it separately.

When making continuity tests, see that the control-grid leads do not touch the chassis.

G. Antenna:

Two antenna posts are provided on the set, marked "Long Antenna" and "Short Antenna." The Long-Antenna post gives somewhat greater selectivity.

Indoor aerials for the screen-grid receivers should be erected as far as possible away from grounded metal, such as pipes, steel beams, electric wiring, etc. **A good outside antenna is recommended in preference to an indoor antenna.**

H. Ground:

It is necessary to use a good ground connection. In some cases, depending on the installation conditions, the sets will work satisfactorily without a ground, but for best results we strongly advise the use of a good ground connection.

I. Output Tubes:

The two A. F. output tubes (2A and 2Aa) should be matched on a tube tester, otherwise the set may hum.

The speaker-plug must not be removed from its socket while the set is in operation.

J. Local-Distance Switch:

The set should be operated with the local-distance switch in the local position when receiving near-by stations. Failure to do this may result in distortion when receiving near-by stations. This use of the local-distance switch should be explained to owners, in order to avoid unnecessary discussion.

K. Phonograph Adaptors:

Owing to the fact that resistance coupling is used between the detector and the 1st audio stage on Model 55, 55-F, 60 and 66, the usual type of phonograph pick-up may not give satisfactory volume on these receivers. However, some manufacturers have special pick-ups for these models.

PLANNING THE SERVICE DEPARTMENT

1. The Service Room

The first thought of the dealer, once he has been "sold on the idea" of rendering real service, will be a suitable workshop or service room in which to carry on this work, and also the tools and equipment he will require to perform radio service completely and efficiently.

In most cases it will be necessary for the dealer to utilize for his service room whatever location may be available for this purpose under the conditions of his present floor layout, but where there is a choice, or in case of the occupying of new quarters where any desired layout can be planned, it is suggested that the service and parts stock room be arranged adjoining or convenient to the rear of the sales and display room. With this arrangement, customers bringing sets in for service can be referred promptly to the "Service Department," which will avoid unnecessary delay and interference with the work of the floor salesman. The dealer's "outside service man" can, of course, enter the shop by the rear entrance.

The service room need not be very large, but should be well lighted. If possible to have outside light directly on the service bench or table from one side or the rear, it will enable the service man to work more efficiently and consequently to produce better results.

2. The Repair Bench

The service bench or "repair table" should be four or five feet long and about twenty inches deep. The height should be about thirty-six inches, so as to permit the repairman to work at it conveniently while standing. The top of the table should be of fairly heavy pine wood, and the legs should be heavy enough to insure the bench being absolutely firm and free from vibration. One or two round-topped stools can be provided for the men when working on jobs requiring considerable time.

3. Suggestions for Service Equipment

A reasonably complete outfit of meters and tools, which will cover the making of any ordinary tests and repairs, is suggested as an initial equipment for the dealer's service room, and consists of the following:

Voltmeter panel (see Page 39 for description).

Multi-wave oscillator covering the broadcast range and also 130 K. C.

Milliammeter, 0-100 M. A.

A separate continuity testing meter or "ohmmeter."

Tube testing device (any standard make).

Hydrometer.

Soldering iron and equipment.

Testing prongs with cables (several pair).

Set of small open-end hex. wrenches.

Set of small socket type hex. wrenches.

Open end wrench for toggle switch (for $\frac{3}{8}$ -inch hex. nut).

Assortment of screw drivers, pliers and wire cutters.

Assortment of spring type clips for quick connections.

Assortment of small fuses (1 and 2 Amp. and 100 M. A.)

Pair of special wrenches for removing cone of E speaker (Part No. 9255).

Jig for setting volume-control contact (Part No. 15115).

Set of three shims for centering the voice coil in electro-dynamic speakers (Part No. 20171).

Three gauges for centering top-pole-piece in electro-dynamic speakers. Each gauge consists of a three-inch length of No. 54 drill rod.

Two specially-drilled top plates for use in synchronizing condensers in screen-grid receivers. See Page 31 for details.

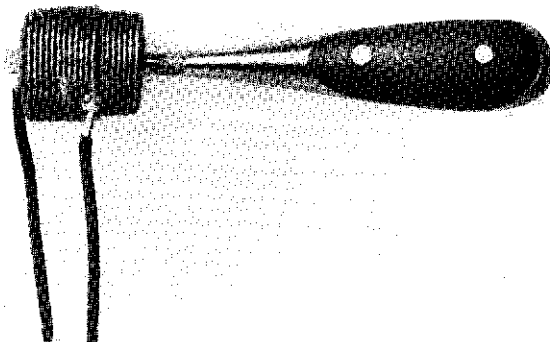

TO 6-VOLT BATTERY

FIG. 33. MAGNETIZING A SCREW DRIVER.

A magnetized screw driver is of great assistance in removing and inserting screws in places which are ordinarily difficult to get at, and it is suggested the dealer prepare one. To magnetize a screw driver, simply insert the blade inside a coil about 50 turns of No. 18 or other insulated wire, the terminals of which are connected to a 6-volt battery and close the circuit for a moment.

4. Arranging the Equipment

All tools frequently used should be kept in a definite place where they will be accessible without delay. A row of hooks at one end of the work table or on the wall can be recommended for this.

The testing equipment may be arranged as shown on Page 38.

Planning the Service Department (Continued)

5. Locating Repair Parts Stock and Repair Material

The best method of arranging the stock of repair parts is to keep them in rows of small wooden bins or in glass jars on sets of shelves on the wall. Each bin or jar should be carefully labeled with the part number and name.

It will also be advisable to have an additional set of shelves for complete sets and speakers—for example a shelf for jobs "to be repaired," one for sets "ready for delivery," and one for sets "awaiting instructions" from the owner or waiting for parts which have been ordered.

6. Equipment for the Outside Service Man

The amount and type of equipment provided for the dealer's "outside service man" will depend on the total investment being made in service equipment, and the ability of the outside man in using meters, etc., to locate and perhaps repair minor troubles in the customer's home.

As a rule it is preferable to make only the external tests in the customer's home, and if trouble is found to be within the set or speaker they can be loaded into the service truck and brought to the shop. This avoids the bad psychological effect of making an actual set repair in the presence of the owner.

There are several complete set testing outfits or "analyzers" on the market made by reliable companies, ranging in price from \$50.00 to \$200.00 or more (retail price). These include all necessary voltmeters, ammeters, tube testers and, in some cases, an oscillator for use in synchronizing variable condensers.

If the dealer does not feel able to invest in one of these outfits, the following set of articles is suggested. Additions can be made as found advisable:

- Soldering iron.
- Screw drivers, several sizes.
- Wrenches, hex., several sizes.
- Combination pliers and wire cutters.
- Hydrometer.
- A. C. voltmeter, 4-8-150 volts.
- 0-50-250 D. C. voltmeter (1000-ohm-per-volt type).
- Tubes—one or two of each type.
- Headphones or speaker.
- Continuity tester (described on Page 36).

The above equipment will provide for checking all batteries, tubes and the speaker, as well as the D. C. voltage of any circuit of set or power unit. Any troubles outside the set can thereby be immediately detected and if the difficulty is traced down to the set it can be disconnected and brought to the service shop for the usual routine circuit and voltage tests, and necessary repairs.

7. Keeping Records on Service

This feature is one which the dealer cannot afford to neglect if a smooth-running Service Department is to be maintained, and if the avoidance of misunderstandings with the customer and unnecessary correspondence with the distributor is desired.

Pads of printed forms, serially numbered and with sufficient copies for office records and the customer, should be used for handling repair jobs, and the date on which a set is brought in for repair, date repair is made, and also delivery date with customer's signature obtained, should be carefully entered.

It is extremely important for the dealer to fill out the warranty tag that accompanies each set and promptly return the post card section to his distributor. The dealer-record-card should be filed for reference in order to determine whether future repair jobs are in the warranty period.

If a repair "invoice" is made out separately, the number of the repair tag and all other data should be placed on the invoice.

All expenditures in the line of service should be recorded carefully in a suitable book, so that at the end of the year a comparison can be made between the cost of maintenance of the department and the total income from repair work done. The latter will, of course, be made up of the profit in repair parts and the amount charged for labor on repair work.

We also recommend the keeping of a careful "inventory" of the stock of repair parts. A "perpetual inventory" is the best if care is taken to keep it up to date. A record card should be maintained for each item kept in stock, and the quantity of this item and date received from the distributor recorded, as well as the date and repair number whenever one is used on a repair job. By going over the stock once a month or so, and checking the inventory, any items on which the stock is getting low can be ordered from the distributor and thus an adequate stock of all parts may be kept on hand at all times.

8. Service Personnel—the Psychology of Service

In the selection of a man or men to handle the Service Department of his store, the dealer should consider three main factors:

- 1—Education and experience.
- 2—Natural ability on radio repair work.
- 3—Ability to meet the customer.

It is self-evident that to perform satisfactory work as a radio service man, experience along radio lines and ability along the lines of electrical and mechanical repair

Planning the Service Department (Continued)

work are essential. The third factor, however, is not usually given due consideration, in fact too often it is sadly overlooked.

The Service Department, rather than being looked upon as a necessary evil (as it was several years ago before the dealer had been educated to its true value), is now considered one of the biggest factors for building good-will and indirectly increasing sales that the dealer can possibly have. But this is not possible unless the service man takes the proper attitude toward the customers and his own work. He should always assume the attitude that "the customer is right." He should listen politely to his story of his trouble and endeavor to assure him cheerfully and convincingly that his difficulty will soon be a thing of the past. Confidence in the product and in his own ability will be a powerful factor in the service man's favor in this connection. He should never argue with a customer and never make promises he cannot fulfill. All appointments made should be kept without fail.

All in all, a proper understanding of the psychology of service on the part of the service man will help to make the Service Department a great asset to the eventual success of the radio dealer's business.

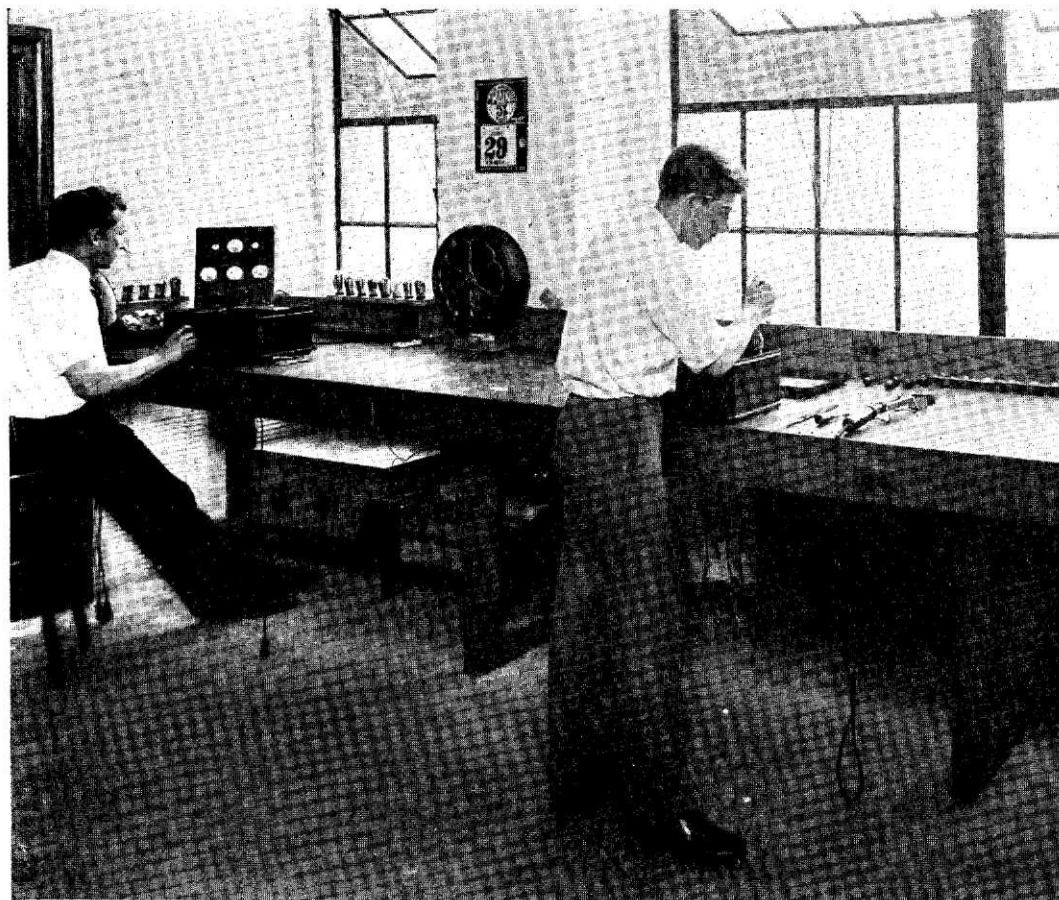

FIG. 34. TWO VIEWS OF A WELL-LAID-OUT SERVICE ROOM.

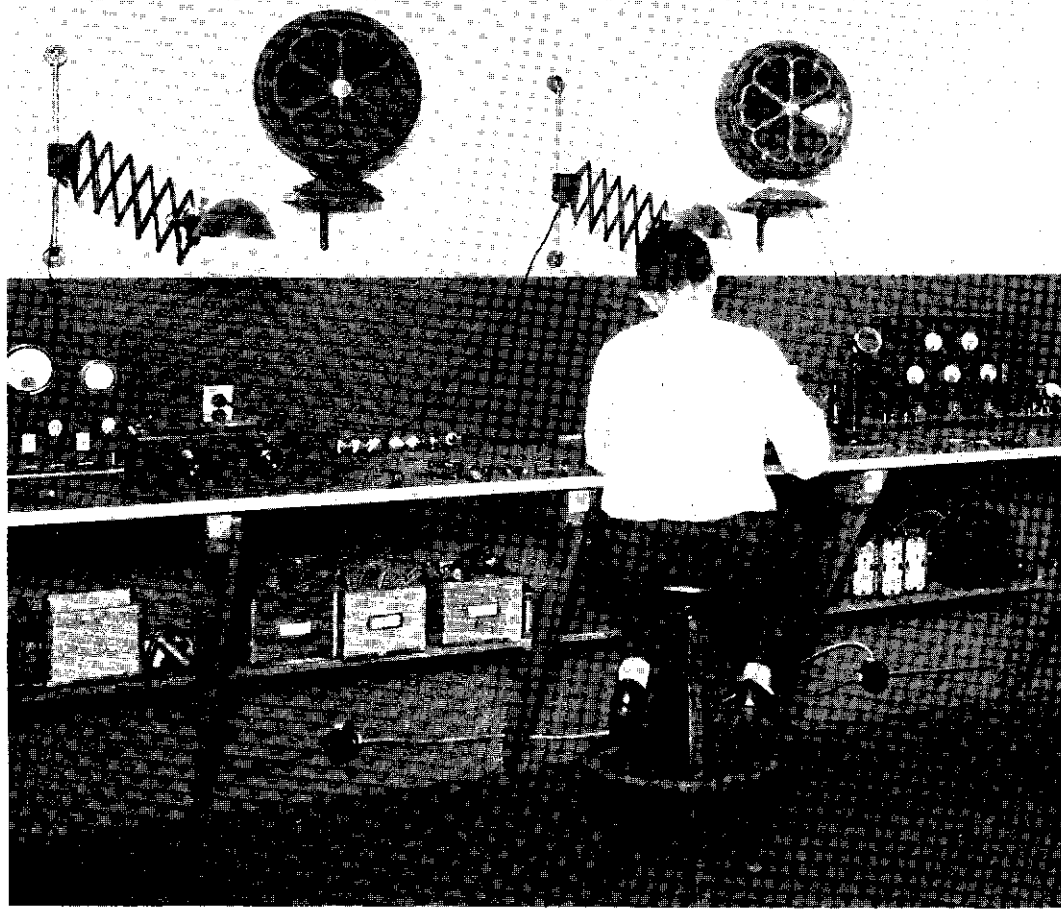

FIG. 35. ANOTHER WELL-ARRANGED SERVICE DEPARTMENT.

TESTING PROCEDURE

Points for Inspection

The following features should be given special attention in making the general visual inspection:

- 1—**SOLDERED JOINTS**—examine for firmness. A poor physical joint means a poor electrical connection. **Note especially ground lug connections.**
- 2—**SCREWS, BOLTS AND NUTS**—must be all tight.
- 3—**INSULATION ON WIRING**—must be perfect and not cut or frayed through where it passes metal edges of tube contacts, etc.
- 4—**TUBE SOCKET CONTACTS**—should be clean and tight.
- 5—**SWITCHES**—switch blades should be clean and make good contact. (Types other than toggle.)
- 6—**DIAL KNOB**—should operate smoothly and quietly.
- 7—**RESISTORS**—note if intact and tightly riveted or clamped in place.
- 8—**R. F. TRANSFORMERS**—examine for loose or damaged coils, or poor connections at terminals.
- 9—**VARIABLE CONDENSERS**—check for foreign particles between plates and note spacing between rotary and stationary plates.
- 10—**RHEOSTATS or VOLUME CONTROL**—must operate smoothly.
- 11—**POWER SUPPLY CABLE**—note condition of insulation on leads and condition of terminals at power end.
- 12—**POWER UNIT (Early A. C. SETS)**—cable connection panel must be bolted down tightly.

The set may then be tested in the following way:

(a) If there is no visible damage to the set (such as a shorted power unit with sealing-compound run over the edge, scratched R. F. transformers, broken tube sockets, etc.) it should be connected for operation, with all tubes in their sockets, and measurements should then be made of the plate, grid, and filament voltages. (Also check the volume control for smoothness of operation.)

These voltage measurements will usually indicate the exact source of trouble and the set may then be disassembled, if necessary, and repaired.

(b) After being repaired, and before reassembling in cabinet, it is advisable to apply continuity tests to the chassis and power unit. The continuity tests give a further check and minimize the possibility of delay in assembling the set before it is fully repaired.

(c) When repaired and assembled, the set should be connected to the output-measuring-circuit and oscillator and the variable condensers should be synchronized. Also again check the operation of the volume control. If a new power unit has been installed, the plate, grid-bias, and filament voltages should be measured. The set may then be switched over to an outside antenna and tested on broadcast signals.

(d) Before returning the set to the customer, a careful inspection should be made to make certain that all assembly screws are tight, that the tuning dial and volume-control knob are correctly adjusted, that the condenser-pulley set-screws are tight, that the cabinet is in good condition, etc.

CONTINUITY TESTS

All Atwater Kent receivers and power units may be tested for "grounds" and continuity of circuits, coils, resistors, etc., with a simple testing arrangement consisting of a voltmeter and battery connected as shown in Fig. 36. A 0-15 voltmeter with a $22\frac{1}{2}$ volt "B" battery is recommended (the voltmeter should NOT be of a high-resistance type). In order to decrease the voltage across the meter to 15 volts, a volume control should be connected in series with the battery as shown in the diagram. The volume control may be adjusted occasionally to cut out resistance as the battery voltage drops off, thus bringing the voltmeter pointer to the 15 volt mark when the test prongs are touched together. Use the 18-volt tap on the battery.

Where the resistance of the circuit being tested is low, the meter should read practically 15 volts. In testing through the windings of a transformer or resistance unit, however, there will be a corresponding drop in voltage, and when testing across a condenser which is, of course, an insulator for D. C. (direct current) no reading should be obtained. If the results ex-

perienced on a certain test vary from the above general outline, trouble in the circuit or unit being tested is indicated.

In case there is any doubt as to whether a certain part has the correct resistance, it is desirable to compare its reading on the continuity meter with the reading secured on a new part of the same type.

A continuity meter is included in the meter panel described on Page 39.

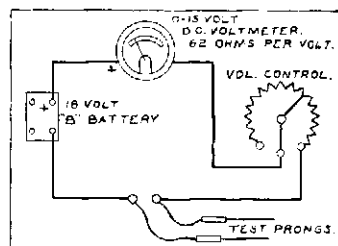

FIG. 36. DIAGRAM OF CONTINUITY TESTING CIRCUIT.

The volume control is part No. 9510.

SYNCHRONIZING VARIABLE CONDENSERS IN BELTED-TYPE RECEIVERS

In order to secure the best sensitivity, volume, and selectivity from a receiver of the single-dial type, it is extremely important that all the tuned circuits be synchronized at all settings of the tuning dial.

If the synchronism has been disturbed in a belted-type receiver, the condensers may be re-synchronized by loosening the pulley set-screws and adjusting the rotor of each condenser separately to give peak output on a constant-strength signal of 1000 kilocycles. The pulley screws are then tightened, and if the condensers and the R. F. transformers are matched, the synchronism should be good at all points on the dial. If the synchronism is not good at other points on the dial, as evidenced by weak reception, either the condensers or the R. F. coil group are not properly matched. In this case a new condenser group or a new transformer group (as necessary) should be installed and the condensers should be re-synchronized.

When synchronizing condensers, it is necessary to use a local oscillator to provide signals and a meter to indicate output volume.

The local oscillator is necessary in order to secure constant signal strength. Signals from broadcast stations are not sufficiently constant for this work.

An output meter is required to secure a reliable indication of output volume. The ear is not reliable for this purpose.

A suitable output measuring circuit is described on Page 41.

The oscillator feeds a weak signal into the receiver. The signal is amplified in the receiver and produces a reading on a meter that is connected to the output of the set. This meter indicates the strength of the output volume.

The reading on the output meter is greatest when all the tuned circuits in the set are adjusted to the same frequency as the oscillator signal. Therefore, if the variable condensers are adjusted separately to produce maximum output volume from the signal, each tuned circuit will be in resonance with the signal and in synchronism with each other.

It is necessary to check the variable condensers at three different broadcast frequencies in order to make certain that the tuned circuits are accurately synchronized at all settings of the tuning dial.

The oscillator must provide modulated signals at 1000, 800 and 600 kilocycles. The pick-up control or attenuator on the oscillator should be calibrated so that it may be re-set at any time to give the same output.

A No. 8112 grid condenser should be connected between the pick-up lead and the antenna post on the set.

The checking and synchronizing procedure is as follows:

Loosen the pulley set-screws on all condensers except the dial condenser. Adjust the rotor of each condenser separately to give peak output on the 600 K. C. signal. Note the position of the oscillator pick-up control and the peak reading of the output meter. Repeat this ad-

justment at 800 K. C. and finally at 1000 K. C.

Carefully tighten the pulley set-screws when the rotors are adjusted for peak output at 1000 K. C. The output reading at 1000 K. C. should be the same after the screws are tightened as before, otherwise the rotors have been disturbed while tightening the screws, and the operation must be repeated.

Now tune to 800 K. C. and readjust the oscillator pick-up to the same position it had when making the previous test at 800 K. C. The reading now, with the pulley screws tightened, should be at least 75% as much as the reading previously secured at this frequency when the rotors were adjusted separately.

The same comparison is made at 600 K. C.

If, with the pulley screws tightened, the output reading at 800 or at 600 K. C. is less than 75% of the reading that was secured when the rotors were adjusted separately, it indicates that either the R. F. transformers or the variable condensers are not matched, and a new group should be installed.

Note that the pulley set-screws are tightened when the rotors are adjusted for peak output at 1000 K. C. The set-screws should not be touched after that.

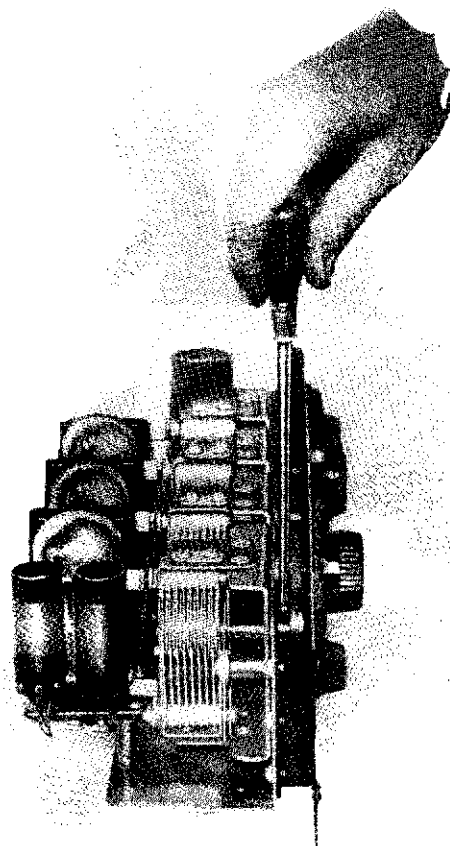

FIG. 37. TIGHTENING PULLEY SET SCREWS AFTER CONDENSERS HAVE BEEN SYNCHRONIZED AT 1,000 KILOCYCLES.

DESCRIPTION OF TESTING EQUIPMENT

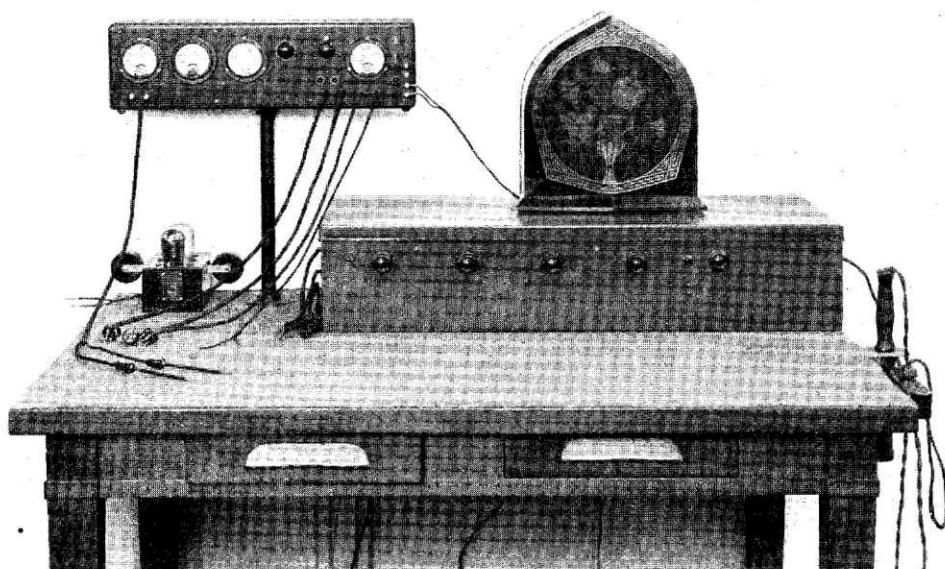

FIG. 38. SUGGESTED ARRANGEMENT FOR A TESTING BENCH.

The complete equipment we suggest for enabling a complete test of any Atwater Kent receiver, together with equipment for measuring the output, is illustrated above.

At the left, supported on the vertical metal stand, is the combination voltmeter testing panel, and output measuring circuit or equipment. Below this is pictured a 130-K. C. oscillator used in testing our superheterodyne models.

To the right is a large metal box housing the four-wave oscillator used to generate signals on four standard broadcast frequencies. On the top of this is shown the inductor type Model JB speaker used to test reception (volume and quality) of any set being tested. A soldering iron for use in repairs is pictured on the extreme right, as is also the plug for deriving power for the test equipment from the local A. C. line. The two drawers in the table are used for tubes and tools.

The four-wave oscillator and the 130-kilocycle oscillator shown in this view are especially constructed and can not be purchased. For dealer use, we recommend the purchase of a well-shielded battery-operated oscillator that covers the broadcast range of frequencies and also 130 kilocycles. The frequency controls should be accurately calibrated, and it should be possible to reduce the pick-up practically to zero or increase it to the

equivalent of a strong local broadcast signal. The pick-up control or attenuator should be calibrated so that it may be re-set to give the same output at any time.

The voltmeter panel includes an A. C. voltmeter, a D. C. voltmeter, a continuity meter, and a switch to cut in the particular meter and voltage range that is required for a given test. There are only two leads from this meter circuit and these are at the left-hand end of the panel.

An output measuring circuit is provided at the right-hand end of the panel. This includes a thermo-coupled milliammeter, three toggle switches, a four-point rotary switch, a special transformer, and other miscellaneous parts. The output circuit is described on Pages 41 and 42.

The voltmeter panel is designed to fit a Model 36 cabinet. The cabinet is mounted on a pipe with flanges at each end, forming a very neat and sturdy mounting.

The top of the test bench should be covered with a sheet of tin which should be grounded through a toggle switch. The switch should be closed when testing A. C. or battery-operated screen-grid receivers and opened when testing D. C.-operated receivers.

The test bench should be used only for testing. A separate bench should be provided for repair work.

Description of Testing Equipment (Continued)
The Voltmeter Panel

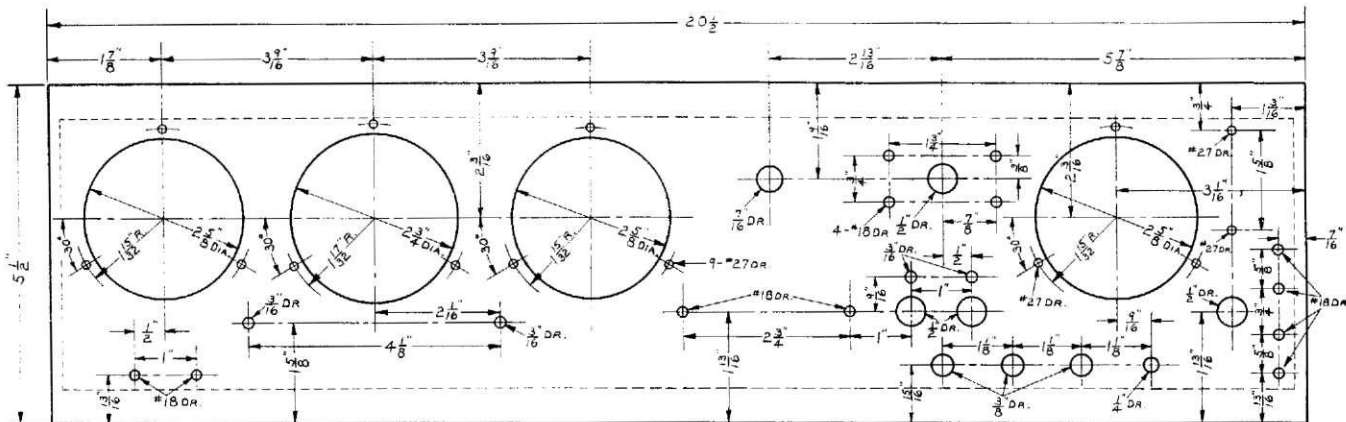

FIG. 39. SUGGESTED LAYOUT FOR VOLTMETER PANEL.

Clips for a fuse are mounted on the front of the panel, at right side of the thermo-galvanometer.

The three meters at the left of the voltmeter panel are connected as shown on Page 40. These meters are used in measuring the voltages and testing the continuity of any Atwater Kent receiver.

The meter at the right of the panel (Fig. 39) is a thermo-galvanometer used in an output measuring circuit described on Page 41.

The equipment required for the voltmeter circuit is as follows:

- 1 Phenolite panel 1/16 inch by 20 1/2 inches by 5 1/2 inches.
- 1 High-resistance D. C. voltmeter, 0-50-250 volts.
- 1 Accurate 200,000-ohm resistor for the 250-volt range of the meter.

- 1 Accurate 250,000-ohm resistor for the 500-volt range of the meter.
- 1 A. C. voltmeter 0-4-8-150 volts.
- 1 D. C. voltmeter, 62-ohms-per-volt, 0-15 volts.
- 1 Part No. 9510 volume control for the continuity circuit.
- 1 Part No. 9991 toggle switch.
- 1 Rotary switch, nine points.
- 1 22 1/2-volt "B" battery. Use the 18-volt tap.
- 1 Pair of testing prongs with leads.
- 4 Part No. 8215 binding posts.

The above parts, except binding posts, toggle switch and volume control, can NOT be purchased from the factory.

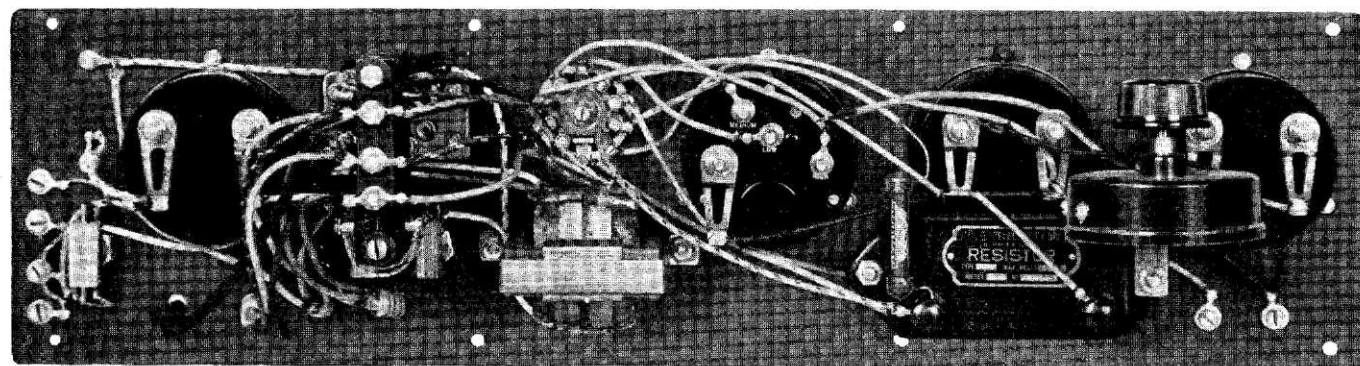

- BINDING POSTS FOR JB SPEAKER AND PHONES SWITCH S1
- THERMO-COUPLED GALVANOMETER "G"
- RESISTORS R1, R2, R3, R4 SWITCHES S2, S3, S4
- TRANSFORMER "T" NINE-POINT SWITCH
- 0-4-8-150 A. C. VOLTMETER
- 250,000-OHM RESISTOR
- 200,000-OHM RESISTOR
- 0-50-250 D. C. HIGH-RESISTANCE METER
- PART NO. 9510 VOLUME CONTROL
- BINDING POSTS FOR TEST POINTS
- 0-15 VOLTMETER

FIG. 39-A. REAR VIEW OF METER PANEL.

Description of Testing Equipment (Continued)

The Voltmeter Panel

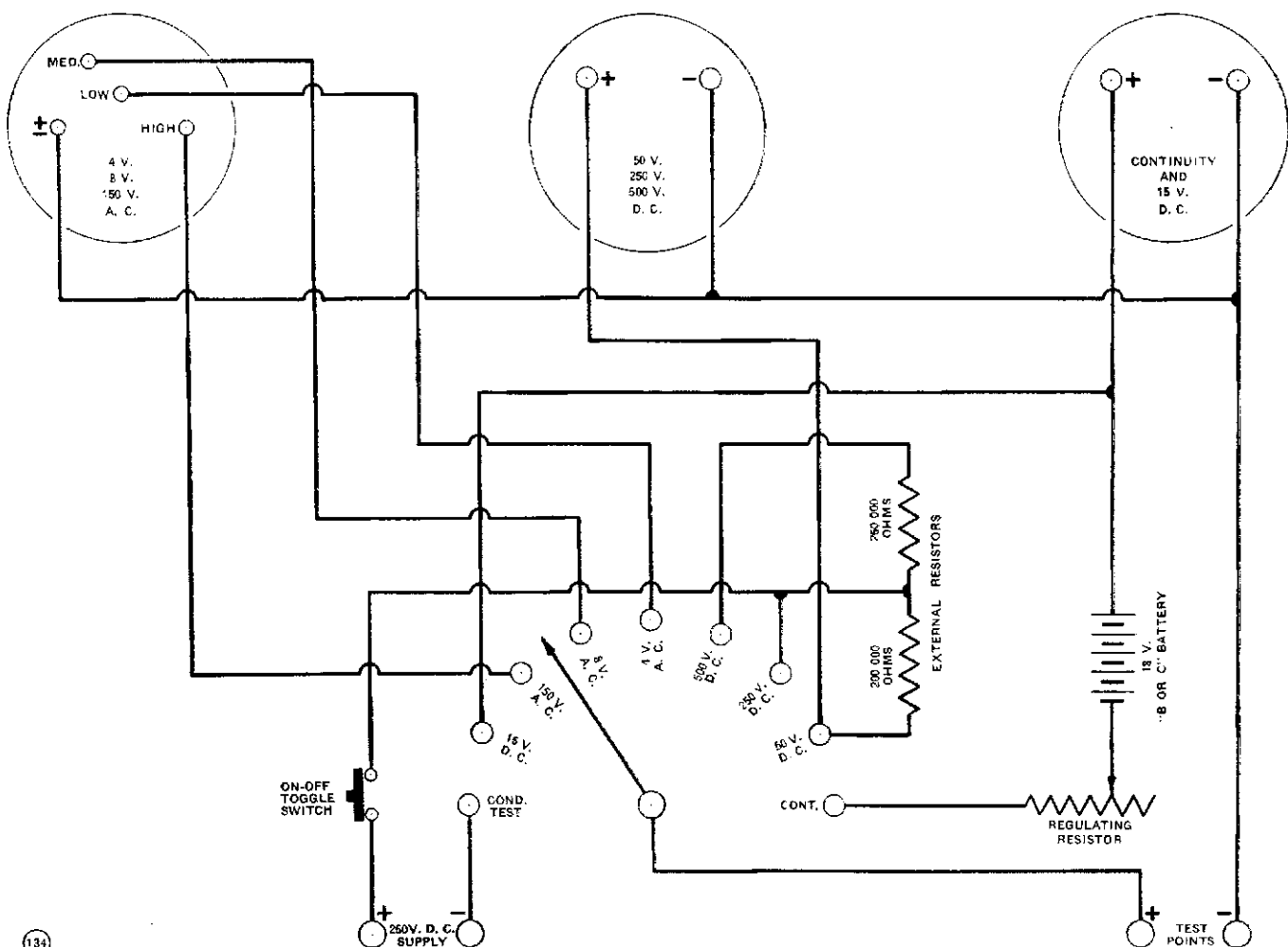

FIG. 40. DIAGRAM OF VOLTMETER TESTING CIRCUIT AS SEEN FROM REAR.

The high-resistance D. C. voltmeter has a scale reading of 0-50-250 volts, but utilizes external resistors for the 250 and 500 volt ranges. These resistors must be accurate.

The A. C. voltmeter is used for measuring line voltage, the filament voltage of A. C. receivers and all other circuits where A. C. is present and a measurement is required.

The high-resistance D. C. voltmeter is used to check plate and grid voltage, filament voltage on D. C. sets, battery voltage, "B" power units, etc. In general it is desirable to use the 250 or 500 volt scale when checking grid or plate voltage.

The continuity meter is used for checking resistors, transformers, chokes, condensers and other parts for

open circuits or short circuits. The regulating resistor (volume control) should be adjusted to give full scale deflection when the test points are touched together.

The condenser test using 250 volts is for use in checking leakage in high-voltage paper-dielectric filter condensers. It should not be used in testing filament-circuit by-pass condensers; the latter should be tested with the continuity meter which employs only 18 volts.

The 250-volt supply for the condenser test may be secured from a "B" power unit or from a Model 42 power unit.

Description of Testing Equipment (Continued)

Output Measuring Circuit for Sets Prior to Model 84

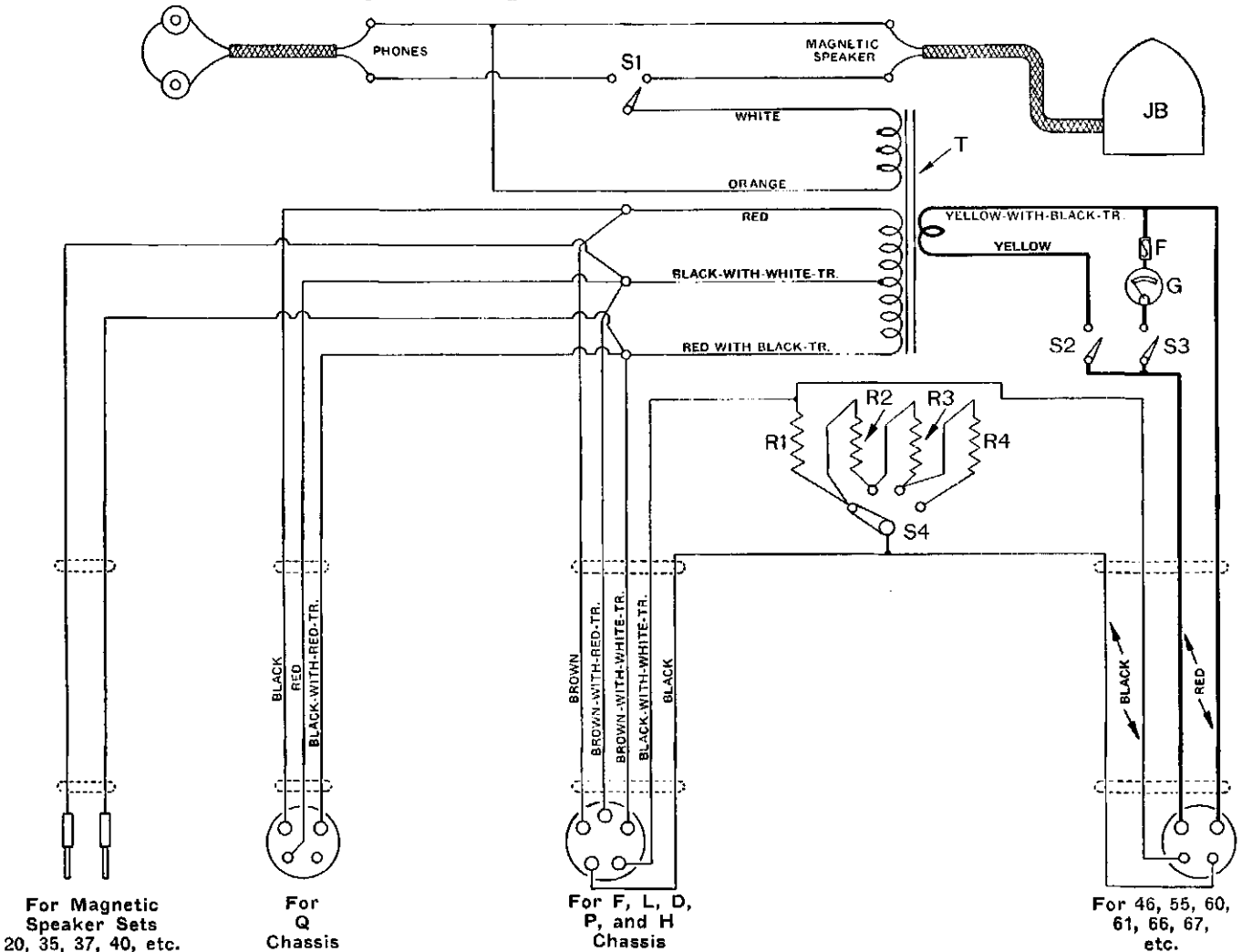

CAUTION—USE ONLY ONE OF THESE FOUR CABLES AT ONE TIME

FIG. 41. DIAGRAM OF OUTPUT MEASURING CIRCUIT.

An output measuring circuit is provided at the right-hand end of the meter panel shown on Page 38. The output meter is used in synchronizing variable condensers as explained on Page 37.

The diagram of this output measuring circuit is shown above. Its main advantage is that only one speaker, a type JB, is required in testing any type of Atwater Kent receiver. This eliminates the necessity of tying up four or five electro-dynamic speakers. This improvement is made possible through the use of a special output transformer, and a series of resistors which take the place of the field coil in the various types of Atwater Kent electro-dynamic speakers.

(If it is not convenient to build an output measuring circuit of this type, we recommend the use of a multi-range rectifier-type 4000-ohm A. C. voltmeter with a full scale reading of about 150 volts. This forms a very satisfactory device and may be purchased from most service-instrument manufacturers. In order to use this meter with an electro-dynamic receiver, it is necessary to have the correct electro-dynamic speaker connected

to the set. Follow the manufacturers instructions regarding the connections for meter.)

Operation of Output Circuit

(A) Throw S1 to the right to test for quality on the JB speaker.

Throw S1 to the left to pick up oscillator signals on the phones when synchronizing variable condensers.

(B) When testing an A. C.-operated electro-dynamic set, move S4 to the tap that gives the correct resistance to take the place of the field coil in the speaker for that particular set.

- Tap 1 (left) takes place of F-6 field coil.
- Tap 2 takes place of F-4 or N field coil.
- Tap 3 takes place of F-2 field coil.
- Tap 4 takes place of F field coil.

It is NOT necessary to use a "dummy" field load when testing a battery-operated or D. C.-operated electro-dynamic receiver. When testing such a receiver, S4 may be turned to the 4th tap (right).

(Continued on next page.)

Description of Testing Equipment (Continued)

Output Measuring Circuit

(C) MAGNETIC SETS. When testing a magnetic-type set, such as Model 20, 35, 37, 40, etc., connect the two-conductor cord to the speaker-posts on the set being tested. Close both S2 and S3 if a reading on the meter is desired; open either S2 or S3 to open the meter circuit.

(D) INDUCTOR SETS. In testing a Type Q chassis, insert the three-conductor plug in the speaker-plug socket on the Q Chassis. Close both S2 and S3 if a reading is desired on the output meter. Open either S2 or S3 to open the meter circuit.

(E) FIVE-PRONG ELECTRO-DYNAMIC SETS. In testing an L, P, D, F or H Chassis, insert the five-conductor plug in the speaker-plug socket on the chassis, and, if the chassis is A. C.-operated, set S4 at the correct tap. To get a reading on the meter, close S2 and S3; to open the meter circuit, open either S2 or S3.

(F) FOUR-PRONG ELECTRO-DYNAMIC SETS. In testing a Model 46, 55, 60, 61, 66, 67, etc., insert the four-conductor plug in the speaker-plug socket on the chassis. If the chassis is A. C.-operated, set S4 at the correct tap. To get a reading on the meter, close S3 and open S2. To operate the phones or JB speaker,

close S2 and open S3. To operate both the phones and the meter, close both S2 and S3.

List of Parts

The meter "G" and the fuse "F" are NOT supplied from the factory.

(T) No. 18911 output transformer. This transformer has an extra winding which couples the speaker or phones to the output circuit of the particular set that is being tested.

- S1—No. 13678 toggle switch.
- S2, S3—No. 9991 toggle switches.
- S4—No. 16430 switch.
- R1—Four No. 16988 resistors in series.
- R2—Three No. 16988 resistors in series.
- R3—Four No. 16988 resistors in series.
- R4—Five No. 16988 resistors in series.
- F—1/4 ampere fuse.
- G—115 ma, thermo-coupled galvanometer.
- I—No. 14169 double-conductor cord.
- I—No. 17866 three-conductor cord-and-plug.
- I—No. 17556 four-conductor cord-and-plug.
- I—No. 17895 five-conductor cord-and-plug.
- 4—No. 8215 binding posts.

ABBREVIATIONS USED IN VOLTAGE TABLES

Abbreviation	Meaning
1 R.....	1st radio frequency socket
2 R.....	2nd radio frequency socket
3 R.....	3rd radio frequency socket
4 R.....	4th radio frequency socket
D.....	Detector socket
1 A.....	1st audio frequency socket
2 A.....	2nd audio frequency socket
2Aa.....	2nd audio frequency socket
3 A.....	3rd audio frequency socket
+ F.....	Positive filament contact
- F.....	Negative filament contact
G.....	Grid contact
P.....	Plate contact
S.....	Screen-grid contact
C (in A. C. sets).....	Cathode contact
R. F. T.....	Radio frequency transformer
A. F. T.....	Audio frequency transformer

In the tables, to identify a certain contact of a certain socket, the abbreviation of the contact is combined with the abbreviation of the socket.

Thus the grid (G) contact of the third R. F. socket is referred to as G3R. The negative filament contact of the second A. F. socket is referred to as -F2A. The cathode of the detector socket (in A. C. sets) is CD. P2A means the plate contact of the second audio frequency socket, and so on.

The use of these symbols will enable the service man quickly to recognize the corresponding socket on the set without having to refer to the chart or wiring diagram.

In all cases where "-F" and "+F" appear on the diagrams and drawings of Atwater Kent A.-C.-operated receivers, these markings are used for identification purposes only, as the A. C.-operated filaments or heaters have no fixed polarity.

OPERATING VOLTAGE TESTS

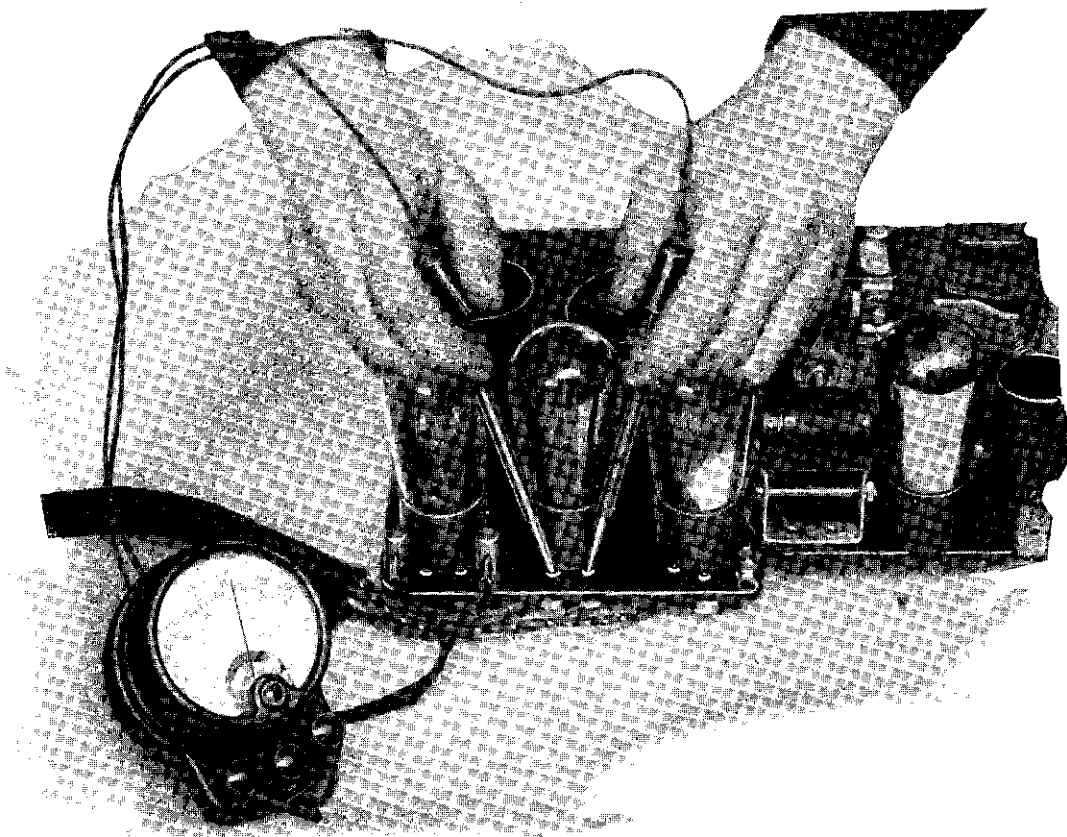

FIG. 42. BY MAKING CONTACT TO THE SOCKET EYELETS, IT IS POSSIBLE TO MEASURE VOLTAGES WITHOUT REMOVING THE CHASSIS FROM CABINET.

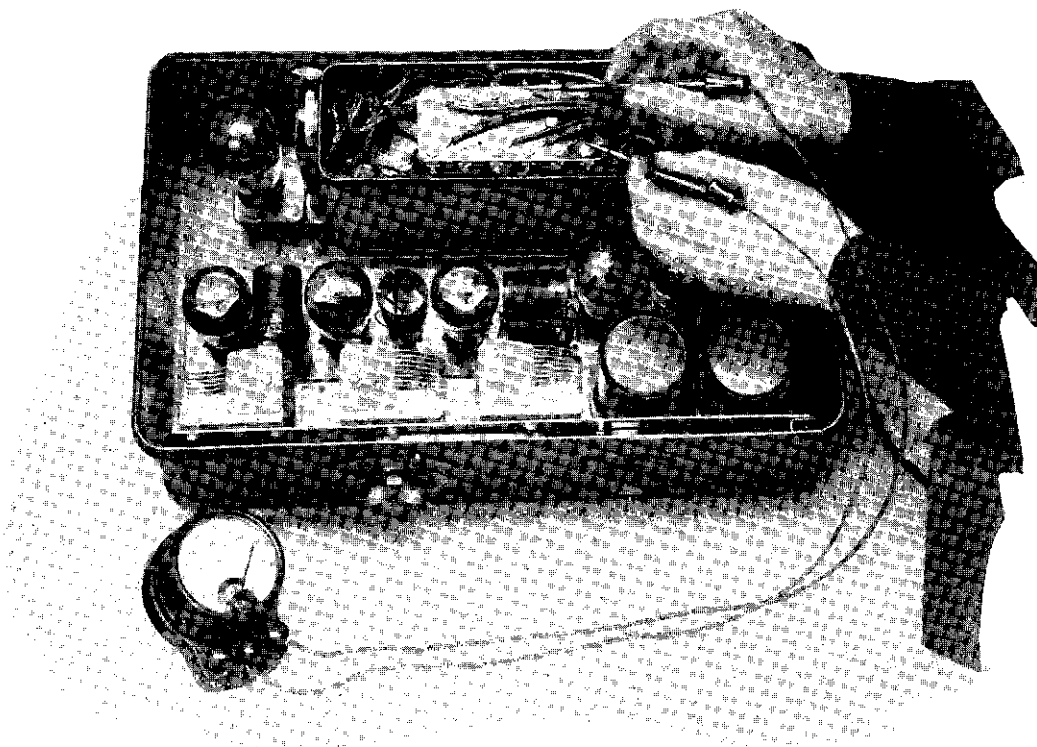

FIG. 42-A. MEASURING THE +B DETECTOR VOLTAGE AT THE POWER-UNIT TERMINALS.

Operating Voltage Tests (Continued)

The table of voltages (for A. C. receivers prior to screen-grid) on the facing page, is arranged logically to trace defects from the source of power, and it is advisable to follow the table as given. The sketch Fig. 42-B of the top view of Model 42 type of receiver shows clearly the identification of the various socket-contact eyelets in all Atwater Kent receivers of this general type. These eyelets are partly covered by the tube bases, when the tubes are in the sockets, but contact may be made to the eyelets through long, thin brass or steel test prongs, sharpened at the ends. The prongs should be pressed down on the eyelets and twisted in order to remove the insulating coating from the eyelets and make good contact. In screen-grid models, the socket-contact eyelets can not be reached from the top of the set, so it is necessary to invert the receiver and remove the bottom plate, thus exposing all socket-contacts, etc. A chart showing the identification of these contacts is given in the description of each screen-grid receiver.

If it is necessary to remove the chassis or power unit from the cabinet to make repairs, we suggest that the regular continuity tests be applied to these parts before reassembling in the cabinet.

In using the accompanying voltage table (for receivers prior to screen-grid) remember that the voltages listed are only approximate, being the average values for the various models.

When testing a defective set, many service men prefer to locate the defective part or circuit before removing the chassis or power unit from the cabinet. This may be done by measuring the plate, grid, and filament voltages at the power-unit terminals and at each tube socket while the set is connected for operation, with all tubes in their sockets and the 110-volt supply current turned on. If made systematically, the voltage measurements provide a quick method of locating defective parts. The voltages at the terminals of the power unit should be measured first, and then the voltages at the tube sockets, making contact through the eyelets that clamp the socket-contacts to the molded base. The illustrations, Figs. 42 and 42A show how the voltmeter leads are put in contact with the socket-eyelets, or with the power-unit terminals, when making measurements. In screen-grid type receivers, the set should be inverted, with bottom plate removed, and measurements made directly to the socket-contacts, as outlined in the voltage table which accompanies the description of each screen-grid receiver.

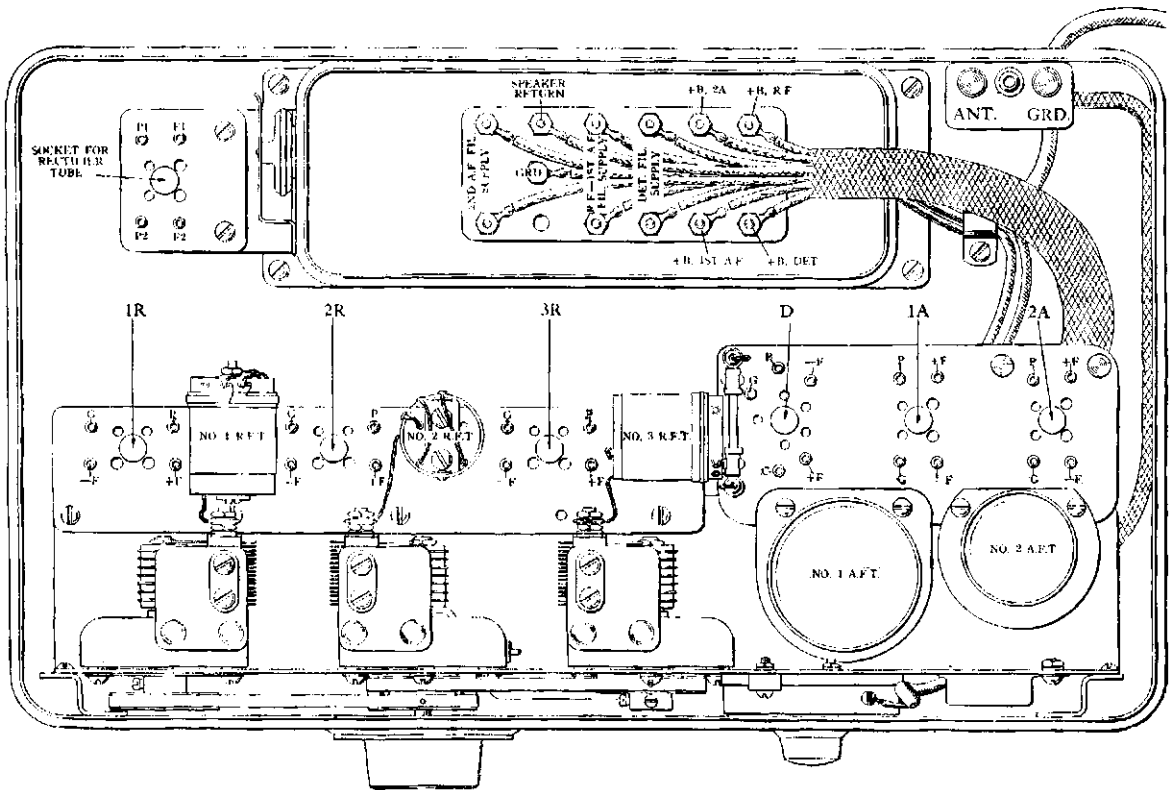

FIG. 42-B. TOP VIEW OF MODEL 42 RECEIVER.

The identification of socket-contact eyelets in this view may be applied to all Atwater Kent receivers of this general type.

The voltage of the three filament circuits are approximately as follows:

R. F.-1st-A. F. filament supply terminals—1.5 volts.

Detector filament supply terminals—2.5 volts.

2nd-A. F. filament supply terminals—5.0 volts.

VOLTAGE READINGS ON A. C. SETS (Prior to Screen-Grid)

TESTS MADE WITH SET IN OPERATION, ALL TUBES IN SOCKETS

Use High-Resistance D. C. Voltmeter (About 0-50-250) To Measure Plate and Grid Voltages. Use A. C. Voltmeter To Measure Filament Voltages.

MAKE TESTS IN ORDER LISTED

Voltages at Power Unit

	MEASURE ACROSS	Approx. Voltage	NO VOLTAGE INDICATES**	REMEDY
FILAMENT VOLTAGES	2.5V Fil. Supply Terminals.	2.1	Open filament winding or open connection in power transformer.	Replace power transformer assembly.
	1.5V Fil. Supply Terminals.	1.5		
	5V Fil. Supply Terminals.	4.9		
	F1 to F2 (on Rect. Socket).	4.9		
"B" VOLTAGES**	One 1.5V Fil. Supply Terminal to +B, R.F.	180	Open high-voltage winding, open filter choke or open R.F.-1st-A.F. bias resistor.	Apply continuity tests across filter and high-voltage winding. Repair as necessary.
	One 1.5V Fil. Supply Terminal to +B, 1st-A.F.	155	Open 1st-A.F. plate resistor.	Replace resistor.
	One 2.5V Fil. Supply Terminal to +B, Det.	45	Open Det. plate resistor.	Replace resistor.
	One 5V Fil. Supply Terminal to +B, 2A.	180	Open speaker-choke, open pri. of output trans., or open 2nd-A.F. bias resistor.	Replace defective assembly.
BIAS VOLTAGES	Ground to one 1.5V Fil. Supply Terminal.	13	Open R.F.-1st-A.F. grid-bias resistor.	Replace defective resistor.
	Ground to one 5V Fil. Supply Terminal.	45*	Open 2nd-A.F. grid-bias resistor.	

Voltages at Tube Sockets

	MEASURE ACROSS SOCKET EYELETS	Approx. Voltage	NO VOLTAGE INDICATES**	REMEDY
FILAMENT VOLTAGES	-F to +F on each R.F. Socket and on 1st-A.F. Socket.	1.4	Open fil. leads, cable or broken cable connection.	Remove Chassis from cabinet. Apply continuity tests, and repair as necessary.
	-FD to +FD.	2.3		
	-F2A to +F2A.	4.8		
PLATE VOLTAGES**	-F4R to P4R. (4th R.F. not used in all Models.)	160-180	Open white cable lead, open R.F. plates res. or open pri. No. 4 R.F.T.	Test output trans. and connections.
	-F3R to P3R.	160-180	Open white cable lead, open R.F. plate res., or open pri. No. 3 R.F.T.	
	-F2R to P2R.	160-180	Open primary circuit No. 2 R.F.T.	
	-F1R to P1R.	160-180	Open primary circuit No. 1 R.F.T.	
	-FD to PD.	45	Open yel. cable lead, open connection or open primary No. 1 A.F.T.	
	-F1A to P1A.	155	Open black-red-tracer cable or open pri. No. 2 A.F.T.	
	-F2A to P2A.	180	Open connection or open primary of output transformer.	
	-F2Aa to P2Aa. (2Aa tube used on electro-dynamic Sets.)	180		
GRID VOLTAGES	G1R to -F1R.	13	Open ant. coil (choke or secondary of antenna trans.).	Remove Chassis from cabinet. Apply continuity tests, and repair as necessary.
	G2R to -F2R.	13	Open sec. No. 1 R.F.T. or open No. 1 grid resistor.	
	G3R to -F3R.	13	Open sec. No. 2 R.F.T. or open No. 2 grid resistor.	
	G4R to -F4R. (4th R.F. not used in all Models.)	13	Open sec. No. 3 R.F.T. or open No. 3 grid resistor.	
	G1A to -F1A.	13	Open secondary No. 1 A.F.T.	
	G2A to -F2A.	45*	Open secondary No. 2 A.F.T.	
	G2Aa to -F2Aa. (2Aa tube used on electro-dynamic Sets.)	45*	Open secondary No. 2 A.F.T.	

* 15 volts on Model 43.

** Low plate voltage may indicate a leaky condenser. A shorted filter-condenser will cause overheating. The plate voltages in Model 36 and early 37 are lower than given in this table.