



MOCK TEST BEST FOR TIFR,GATE

FULL MARKS:- $25 \times 4 = 100$

DATE:- 23RD SEPTEMBER, 2021

FUTURE OF PHYSICS

FORUM FOR IIT JAM,GATE,JEST,TIFR,NET,DU,JNU



**DR. DIPESH SATPATI, ISRO
ASSOCIATE SPACE SCIENTIST**

**INDIAN SPACE RESEARCH ORG
POST DOCTORAL RESEARCHER; ISCA**



**FUTURE OF PHYSICS
FORUM FOR IIT JAM ,GATE
TIFR, NET,JEST,JNU,DU ETC....**



Q1. The heaviest pebble of mass m that can be moved by a stream is known to be proportional to some powers of the speed of the stream v , the density (of water) ρ and the acceleration due to gravity g . Using dimensional analysis, we may conclude that m is proportional to

- (a) $\frac{\rho v^4}{g}$ (b) $\frac{\rho v^5}{g^2}$ (c) $\frac{\rho v^6}{g^3}$
(d) $\frac{\rho v^3}{g^4}$ (e) $\rho v^2 g$

Q2. A spherical hole of diameter R has been scooped out of a solid sphere of uniform mass density and radius R . The hole is centred at $(x, y, z) = \left(0, 0, \frac{R}{2}\right)$ as shown in the figure.

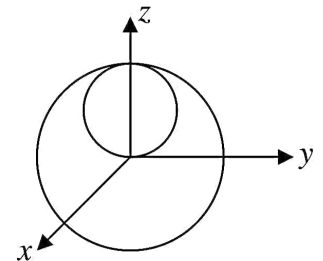

The centre of mass of the body is at

- (a) $\left(0, 0, \frac{-R}{14}\right)$ (b) $\left(0, 0, \frac{R}{2}\right)$ (c) $\left(0, 0, \frac{R}{12}\right)$
(d) $\left(0, 0, \frac{-R}{8}\right)$ (e) $\left(0, 0, \frac{-R}{16}\right)$

Q3. Two particles, of mass m_1 and m_2 , interact through a central force potential $V(r)$. At $t = 0$, their position and velocity vectors are given by $r_1 = (0, 0, a)$, $r_2 = (a, 0, 0)$, $V_1 = (b, 2b, 0)$ and $V_2 = (0, 0, 3b)$, where a and b are constants.

If $m_2 = 2m_1$. Which of the following vectors is perpendicular to the plane of motion?

- (a) $2i + 5j$ (b) $2i - j - k$ (c) $-i + 2j + k$
(d) $i - 3j + 2k$ (e) $i + j + k$



HEAD OFFICE:- BANGALORE

NEAR ISRO SATELITE CENTER

OFFICE EMAIL ID:-

BRANCH OFFICE:- KOLKATA, KHARAGPUR, DELHI

BOMBAY, ORISSA

iitjamjestfutureofphysics@gmail.com

- Q4. A simple harmonic oscillator has a potential energy $V_0(x) = \frac{1}{2}kx^2$. If an additional potential energy term $V_1(x) = ax$ is added to it, then
- (a) the motion is simple harmonic with a decreased frequency, and around a shifted equilibrium
 - (b) the motion is no longer simple harmonic
 - (c) the motion is simple harmonic with an increased frequency, and around a shifted equilibrium
 - (d) the motion is simple harmonic with the same frequency, but around a shifted equilibrium
 - (e) the motion is simple harmonic with an increased frequency around the origin

- Q5. Three balls of mass 10 kg , 20 kg and 10 kg are hanging by a massless string and are connected by massless springs as shown in the figure. Initially the system is in equilibrium and all the objects are at rest.

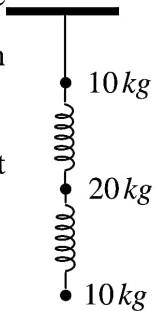

If the string at the top snaps suddenly, what is the acceleration of the topmost ball at that instant of time? [In the following, g denotes the acceleration due to gravity.]

- (a) 0
 - (b) $2g$
 - (c) g
 - (d) $4g$
 - (e) $3g$
- Q6. A binary star is composed of two stars that orbit around their centre of mass under the influence of gravity. Consider such a system in which the two stars have identical mass. In the centre of mass frame, each star moves in a circular orbit with a speed of 200 km/s . If the orbital period is 15 days, what is the approximate mass of each star?
- (a) 10^{32} kg
 - (b) 10^{30} kg
 - (c) 10^{34} kg
 - (d) 10^{28} kg
 - (e) 10^{26} kg
- Q7. The trace and the determinant of a 3×3 matrix A satisfy $\text{Tr}A = 2$ and $\det A = 2$. Further, the sum of two of the eigenvalues of A is equal to the third eigenvalue. Then the trace and the determinant of the matrix A^2 are, respectively
- (a) 2 and 1
 - (b) 0 and 1
 - (c) 4 and 1
 - (d) 4 and 2
 - (e) 4 and 4
-

Q8. Which of the following graphs gives the best qualitative representation of the real valued function $(x+a)e^{-bx^2}$, where a and b are positive constants?

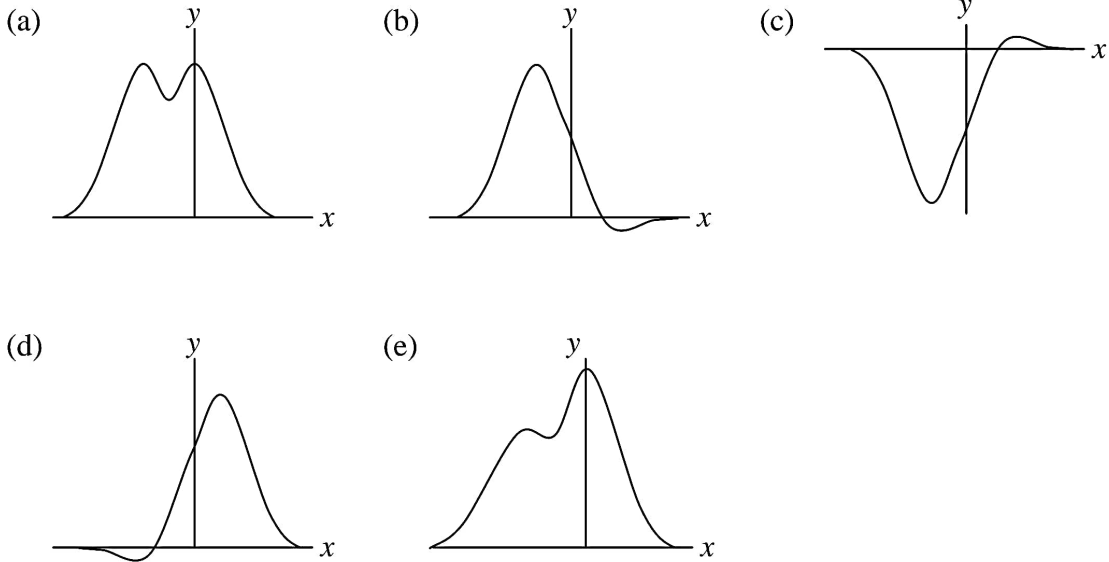

Q9. For $x > 0$, the solution of the differential equation

$$\frac{dy}{dx} + 2xy - \frac{1}{x}e^{-x^2} = 0$$

(with the condition that $y = 0$ at $x = 1$) is [In the following, $\text{Erf}(x) = \frac{2}{\sqrt{\pi}} \int_0^x d\xi e^{-\xi^2}$]

- (a) $e^{-x^2} \ln x$ (b) $\ln x \times \text{Erf}(x)$ (c) $(x-1)e^{-x^2}$
 (d) $1 - \frac{1}{x}$ (e) $\text{Erf}(x-1)$

Q10. Which of the following vector fields can represent an electrostatic field?

- (a) $(2xz - y^2)i + (2xy - z^2)j + (2yz - x^2)k$
 (b) $xyi + 2yzj + 3xzk$
 (c) $yzj - xzj + xyk$
 (d) $y^2i + (2xy + z^2)j + (2yz + x^2)k$
 (e) $y^2i + (2xy + z^2)j + 2yzk$



DR. DIPESH SATPATI, ISRO
ASSOCIATE SPACE SCIENTIST
INDIAN SPACE RESEARCH ORG
POST DOCTORAL RESEARCHER; ISCA

- Q11. A bar magnet of magnetic moment M , is moving with a constant velocity v along the axis of a circular coil of radius R . The direction of the magnetic moment of the bar magnet is parallel to its velocity as shown in the figure below:

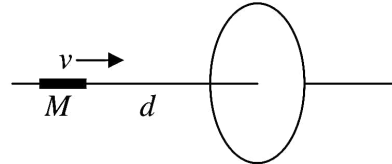

what is the magnitude of the e.m.f induced in the coil at an instant when the magnet is at a distance d (where $d \gg R$) from it ?

- (a) $\frac{\mu_0 R^2 M v}{2d^3}$ (b) $\frac{3\mu_0 R^2 M v}{2d^4}$ (c) $\frac{\mu_0 R^2 M v}{4d^2}$
- (d) $\frac{\mu_0 R^2 M v}{2d^4}$ (e) $\frac{3\mu_0 R^2 M v}{2d^3}$
- Q12. Electric charges Q and $-Q$ are distributed uniformly on the surface of two concentric shells of radii a and b respectively ($a < b$). The energy required to assemble this charge distribution is

- (a) $\frac{Q^2 (b-a)}{4\pi\epsilon_0 (b+a)^2}$ (b) $\frac{Q^2 (b-a)}{8\pi\epsilon_0 ab}$ (c) $\frac{Q^2 (b-a)}{4\pi\epsilon_0 b^2}$
- (d) $\frac{Q^2 (b+a)}{4\pi\epsilon_0 a^2}$ (e) $\frac{Q^2 (b-a)}{8\pi\epsilon_0 a^2}$



- Q13. A rigid current carrying square loop $ABCD$ of side L is situated at a distance L from an infinite straight wire, with the side AB parallel to the latter, as shown in the figure below. The infinite wire, which is in the plane of the loop, carries a current I_1 from right to left, while the loop carries a current I_2 flowing clockwise

The net force between these two current-carrying elements is

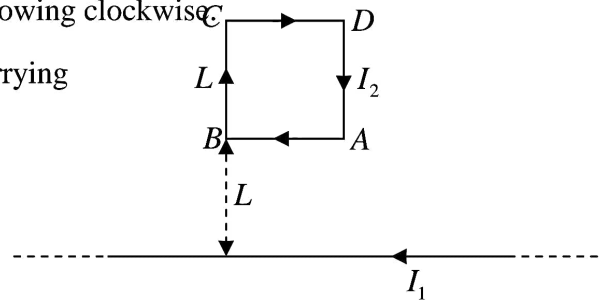

- (a) repulsive of magnitude $\frac{3\mu_0}{4\pi} I_1 I_2$
- (b) repulsive of magnitude $\frac{\mu_0}{2\pi} I_1 I_2$
- (c) attractive of magnitude $\frac{3\mu_0}{2\pi} I_1 I_2$
- (d) attractive of magnitude $\frac{\mu_0}{4\pi} I_1 I_2$
- (e) zero (not force)
- Q14. Which of the following proposed space- time dependent electric fields in vacuum is /are allowed by the equations of electromagnetic theory?
- I. $E_x = E_1 \sin(kz - \omega t), E_y = E_2 \sin(kz - \omega t), E_z = 0$
- II. $E_x = E_1 \sin(kz - \omega t), E_y = 2E_1 \cos(kz - \omega t), E_z = 0$
- III. $E_x = E_1 \sin(kz - \omega t), E_y = 0, E_z \sin[kz - \omega t]$
- [In the above E_1 and E_2 are real constants]
- (a) I and II, but not III
- (b) II and III, but not I
- (c) I and III, but not II
- (d) I only
- (e) I, II and III

- Q15. Two identical tuning forks, vibrating with identical amplitude at the frequency of 660 Hz , are being brought towards a microphone from opposite directions with speeds of 1 m/s and 2 m/s , respectively. Around a time when one tuning fork is 40 cm away from the microphone and the other one is 60 cm away, the wave pattern recorded by the microphone will be characterized by a
- (a) frequency of 660 Hz with constant amplitude
 - (b) frequency of 662 Hz with constant amplitude
 - (c) frequency of 658 Hz with constant amplitude
 - (d) frequency close to 660 Hz , but amplitude modulating at 2 Hz
 - (e) frequency close to 660 Hz , but amplitude modulating at 4 Hz
- Q16. In a Young's double-slit experiment, the light incident on the slits is monochromatic and plane polarized with the direction of polarization being parallel to the slits. If one of the slits is covered by a thin plane polarizer with the easy axis (also known as the transmission axis) at 45° to the slits, the value of the ratio $\frac{I_{\max} - I_{\min}}{I_{\max} + I_{\min}}$ of the fringe pattern is:
- [Hint: You will need to consider the components of the electric field both parallel and perpendicular to the slits. The intensity at the screen is the average value of the sum of the squares of these two components]
- (a) 0
 - (b) $\frac{2}{3}$
 - (c) $\frac{1}{4}$
 - (d) $\frac{4}{5}$
 - (e) $\frac{1}{3}$
- Q17. One mole of an ideal gas (of $\gamma = \frac{5}{3}$) at temperature 400 K is expanded adiabatically till its temperature drops to 200 K . How much heat (in units of the gas constant R) should be supplied to it so as to restore the original temperature without changing the volume further?
- (a) 75
 - (b) 120
 - (c) 133
 - (d) 200
 - (e) 300

- Q18. Suppose 300 g of water at $97^{\circ}C$ is poured into a cup (also of mass 300 g) that is at a temperature of $25^{\circ}C$. If the specific heats of the cup and water are $820 J/kg - K$ and $4100 J/kg - K$, respectively, the changes in the entropy of the water and the cup (after they have attained equilibrium) are, respectively
- (a) -41 and $45 J/K$ (b) -40 and $50 J/K$ (c) -137 and $150 J/K$
 (d) -133 and $167 J/K$ (e) -55 and $55 J/K$
- Q19. A spherical blackbody A of radius 2 cm is maintained at a temperature of 1500 K . Another spherical blackbody B of radius 3 cm is at 1000 K . Let for the blackbody A , I_A and λ_{max}^A denote the total intensity of emitted radiation and the wavelength where maximum radiation is emitted. Let I_B and λ_{max}^B be the corresponding values for the blackbody B . Then
- (a) $2I_A = 3I_B$ and $2\lambda_{\text{max}}^A = 3\lambda_{\text{max}}^B$ (b) $2I_A = 3I_B$ and $3\lambda_{\text{max}}^A = 2\lambda_{\text{max}}^B$
 (c) $4I_A = 9I_B$ and $2\lambda_{\text{max}}^A = 3\lambda_{\text{max}}^B$ (d) $4I_A = 9I_B$ and $3\lambda_{\text{max}}^A = 2\lambda_{\text{max}}^B$
 (e) $I_A = I_B$ and $\lambda_{\text{max}}^A = \lambda_{\text{max}}^B$
- Q20. The density of copper, which has a face-centred cubic (fcc) lattice structure, is 8.9 gm/cm^3 . Given that molar mass of copper is 63.55 , the length of side of the cubic cell is
- (a) 0.45 nm (b) 0.57 nm (c) 0.29 nm
 (d) 0.23 nm (e) 0.36 nm



Q21. Consider the voltage-regulator circuit shown in the figure below:

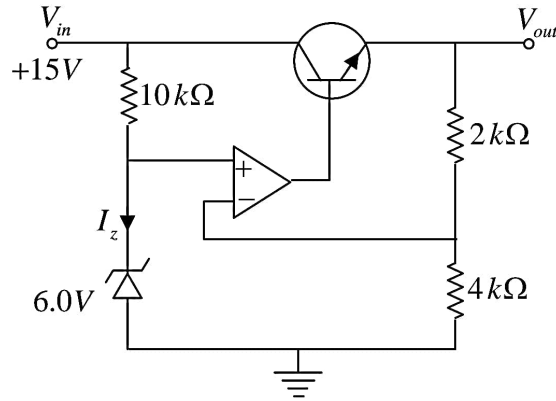

The current in the Zener diode I_z and the output voltage V_{out} are, respectively

- (a) 1.5 mA and 6.0 V (b) 1.5 mA and 9.7 V (c) 0.9 mA and 9.0 V
 (d) 0.9 mA and 8.3 V (e) 0.9 mA and 6.0 V
- Q22. Muons of kinetic energy E are produced in collision with a target in a laboratory. The mass of a muon is $105\text{ MeV}/c^2$ and its half-life is $1.4 \times 10^{-5}\text{ s}$ in its rest frame. What should be the minimum value of E if more than half the muons created at the target are to reach a detector 840 m away?
- (a) 106 MeV (b) 212 MeV (c) 130 MeV
 (d) 189 MeV (e) 162 MeV
- Q23. What is the energy of the second excited state of a particle of mass m moving freely inside a rectangular parallelepiped of sides $L, 2L$, and $3L$?
- (a) $\frac{49h^2}{288mL^2}$ (b) $\frac{9h^2}{32mL^2}$ (c) $\frac{61h^2}{288mL^2}$
 (d) $\frac{11h^2}{36mL^2}$ (e) $\frac{19h^2}{72mL^2}$
- Q24. In the Large Electron Position (LEP) collider electrons were accelerated to an energy of 100 GeV . The ratio of the de Broglie wavelength of these electrons to the de Broglie wavelength of an electron in the ground state of a hydrogen atom is of the order of
- (a) 10^{-5} (b) 10^{-7} (c) 10^{-9}
 (d) 10^{-11} (e) 10^{-13}

Q25. a free neutron is unstable and decays into a proton, an electron and an anti-neutrino $n \rightarrow p + e^- + \bar{\nu}_e$. The rest masses of these particles may be taken to be $m_n = 939.6 \text{ MeV}$, $m_p = 938.3 \text{ MeV}$, $m_e = 0.51 \text{ MeV}$ and $m_{\bar{\nu}_e} = 0$, so that the change in the total rest mass in the decay is 0.79 MeV . If, in a particular decay, the neutron as well as the proton (created due to the decay) are at rest, then the energy of the anti-neutrino is

(a) 1.05 MeV

(b) 0.39 MeV

(c) 0.78 MeV

(d) 0.55 MeV

(e) 0.40 MeV

