



F42K17

**PARTS
MANUAL**



Table of Contents

GENERAL INFORMATION	
ENCORE WARRANTY INFORMATION	A-1
FUZION KAWASAKI QUICK REFERENCE SHEET	A-2
SERVICE LOCATOR CHART	A-3
DECK COMPONENTS	B-1
DECK LIFT COMPONENTS	C-1
FRAME COMPONENTS.....	D-1
DRIVE COMPONENTS.....	E-1
CONTROL COMPONENTS	
RIGHT HAND CONTROL PARTS	F-1
LEFT HAND CONTROL PARTS	F-3
BRAKE COMPONENTS	
RIGHT HAND SIDE	G-1
LEFT HAND SIDE.....	G-3
HYDRO COMPONENTS	H-1
FUEL COMPONENTS.....	I-1
WIRE HARNESS SCHEMATIC	
F42K17 WIRE HARNESS SCHEMATIC.....	J-1
DECAL LIST.....	K-1
NOTES	L-1



WARNING:

THE ENGINE EXHAUST FROM THIS PRODUCT CONTAINS CHEMICALS KNOWN IN THE STATE OF CALIFORNIA TO CAUSE CANCER, BIRTH DEFECTS OR OTHER REPRODUCTIVE HARMS.

IMPORTANT:

A separate Engine Owner's Manual is included with your owner's packet which contains additional engine information that will not be repeated in this manual. You are urged to read it before attempting any operation or repair of the engine. Engine Owner's Manual covers the engine manufactures warranty.

ENCORE WARRANTY

WHAT IS COVERED BY THIS WARRANTY

This warranty extends to the original retail purchaser only and commences on the date of original retail purchase:

1. Residential use: The warranty will be **Three years from the date of purchase** against defects in workmanship and materials for any Encore rider that is used for consumer purpose. Normal residential use means use of product on owners' property only.
2. Commercial use: The warranty will be **One year from the date of purchase and 90 days for rental use** against defects in workmanship and materials for any Encore rider that is used for commercial purpose.
3. If the Purchaser discovers within this warranty period a defect in materials or workmanship:
 - Purchaser must promptly notify an Authorized Encore Dealer and return the mower, including any defective parts, to an Authorized Encore Service Dealer.
 - Encore Mfg. Co. Inc. will determine if material or workmanship is defective and then either repair or replace such parts.
 - Service calls and/or transportation expense of the product to and from the authorized dealer, for warranty work, will be paid by the owner of the product.
3. Encore Mfg. Co., Inc. provides a limited warranty for **One year from the date of purchase** against defects in workmanship and materials for all parts, excluding normal wear items such as batteries, tires, belts and blades.
4. The Deck Shell warranty is **Ten years from the date of purchase** against defects in workmanship and materials for any Encore rider that is used for consumer and commercial use only.
5. **NOTICE:** Cutter housings, electrical components, hydraulic components and electric-clutch must be returned before warranty will be paid.
6. **The engine warranty is covered by its respective manufacturer.** Please refer to the manufacturer's warranty statement in the manufacturer's engine manual that is included in the literature packet. **Engine warranties should be referred to the nearest authorized service outlet of the engine manufacturer.**

Encore Mfg. Co., Inc. reserves the right to change or improve the design of any mower without assuming any obligation to modify any mower previously manufactured.

WHO MUST PERFORM THE WARRANTY SERVICE

All warranty service will be performed by dealers authorized by Encore Mfg., Co., Inc. Service calls and/or transportation expense of the product to and from the authorized dealer, for warranty work, will be paid by the owner of the product. For warranty service you can contact an authorized dealer or contact:

Encore Mfg., Co., Inc.
PO Box 888
Beatrice, Nebraska 68310
1-800-267-4255
www.encoreequipment.com
www.seriousred.com

WHAT IS NOT COVERED BY THIS WARRANTY

Encore Mfg., Co., Inc. does not warranty:

- Repairs made by unauthorized persons.
- Damage caused by use of the Encore equipment for purposes other than those for which it was designed

- Damages caused by disasters such as fire, flood, wind, and lightning.
- Damages caused by neglect, abuse, abnormal use, improper or unreasonable use, accident, negligence or misuse.
- Repairs or replacement resulting from the use of unauthorized parts, accessories or attachments.
- Repairs or replacement as the result of any alterations or modifications, in the determination of Encore, which adversely affects the operation, performance or durability of the equipment.
- Encore unit which has the serial number removed or made illegible.
- Depreciation or damage caused by normal wear, lack of reasonable and proper maintenance or failure to follow the product's owner's manual provided by Encore Mfg. Co., Inc.
- Normal maintenance parts and service including, but not limited to: filters, fuel, lubricants, tune-up parts, belts, blades, blade sharpening, brake or steering adjustments.
- Repairs necessary due to improper fuel, contaminates in the fuel system, or failure to properly prepare the fuel system prior to any period of non-use over three months.

LIMITATION OF REMEDIES

In no case shall Encore Mfg., Co., Inc., be liable for any special, incidental, or consequential damages based upon breach of warranty, breach of contract, negligence, strict liability in tort, or any other legal theory.

Such damages include, but are not limited to

- Loss of profits
- Loss of savings or revenue
- Loss of use of Encore mower or any associated equipment
- Cost of capital
- Cost of any substitute equipment, facilities, services, or downtime
- The claims of third parties including customers, and injury to property
- Some states do not allow the exclusion or limitation of incidental or consequential damages, so the above limitation or exclusion may not apply to you.

OWNER'S RESPONSIBILITY

You must maintain your Encore Product following the maintenance procedures described in your owner's manual. Such routine maintenance, whether performed by a dealer or by you, is at your expense.

This machine, like any other powered equipment, is potentially dangerous unless properly operated. Any operator must be cautious and keep safety in mind at all times. Any operator, prior to using the Encore equipment, should thoroughly familiarize himself with the owner's manual regarding operation and safety of the machine, as well as all safety warnings on the machine itself.

ENCORE MFG. CO., INC. CANNOT BE RESPONSIBLE FOR THE WAY YOU OPERATE, OR THE CONDITIONS IN WHICH YOU OPERATE THE MOWER. USE COMMON SENSE AT ALL TIMES.

WARRANTY REGISTRATION

1. The Warranty registration form **MUST** be completed and forwarded to Encore Mfg., Co., Inc., within fifteen days following date of purchase.
2. The date of purchase constitutes delivery.

Encore Mfg. Co., Inc. does not assume or authorize anyone to assume for them any other obligation.

General Information

Quick Reference Sheet

Engine

17hp Kawasaki electric FH54V-BS31R

Torque Specs

65 ft-lbs blade bolt
90 ft-lbs nut on top of spindle
50 ft-lbs clutch bolt

Blades

423029 14" blade
423014 14" low lift blade
423173 14" mulch blade
423210 14" super hi-lift blade

Pulleys

423262 spindle pulley
523329 stationary idler pulleys
533114 tensioner pulley-blade drive belt
823351 pump tensioner pulley
353101 pump drive pulley

Belts

353114 blade drive belt
353112 pump drive belt

Front Caster Bearings

423200 bearing
423201 bearing retainer

Tires

353126 wheel/tire assy
353148 drive tire (18x9.5x8)
353149 rim w/ valvestem
363311 front caster complete
363260 front tire & tube (4.10/3.50-4)
* * * *
front rim not serviced

Seat

353098 seat complete w/o tracks
593097 molded arm rest

Spindles

583106 spindle assy comp.
583111 housing
363350 bearing
583112 shaft
583113 brg. Spacer tube

Transmission

353127 RH EZT transaxle (Hydro-Gear Model # ZC-ACBB-2YLB-1EXA)
353128 LH EZT transaxle (Hydro-Gear Model # ZC-DCBB-2YLC-1EXA)

*** lifetime lubricated transaxles

Throttle 363352

Choke 523037

Muffler 353179

Wire Harness 353132

Pigtail Harness 353180

Clutch 423285

Electrical Components

423027 Ignition Switch
422150 Starter Relay
583423 Time Delay Module
583351 Relay
523034 Park Brake Switch
593041 Neutral Switch
523031 PTO Switch
353048 Seat Switch
523283 Hour Meter

SERVICE LOCATOR CHART

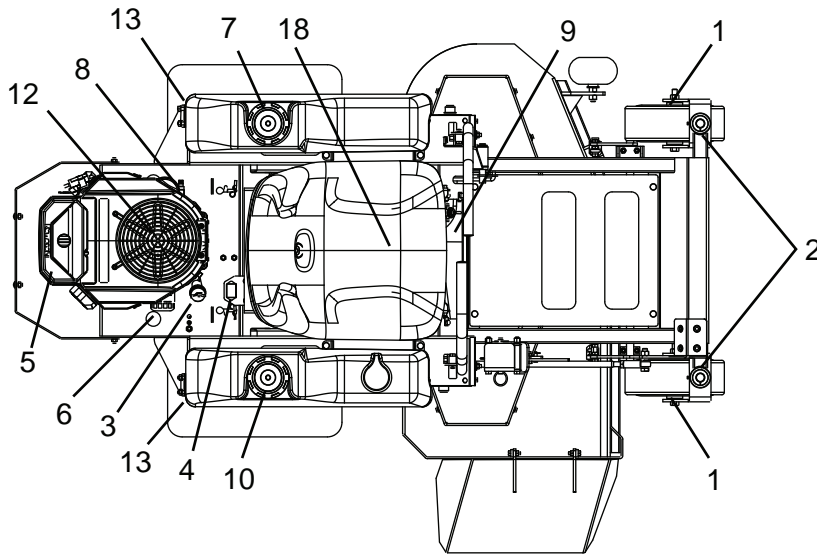

1. Front Caster Wheel Bearings (2)
2. Front Caster Pivot Bearing Zerks (2)
3. Engine Oil Fill & Dipstick
4. Hour Meter
5. Engine Air Filter
6. Engine Oil Filter
7. Fuel Tank
8. Engine Fuel Filter
9. Fuel Shut-off Valve
10. Fuel Tank w/ Cup Holder
11. Hydraulic Bypass
12. Engine Vent Screen
13. Drive Tires
14. Pump Belt (353112)
15. Blade Drive Belt (353114)
16. Front Casters Wheels
17. 14" Blade (423029)
18. Located inside the seat frame under operators seat:
 1. Time delay module
 2. Relays
 3. Fuse Block
 4. Start Relay
 5. Battery

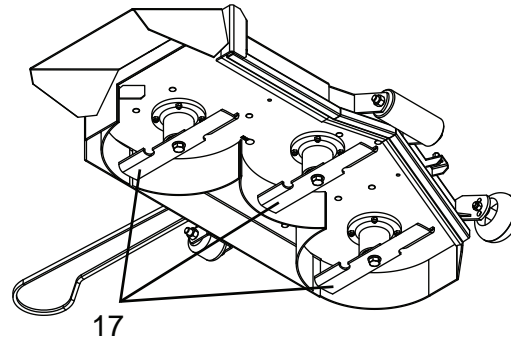
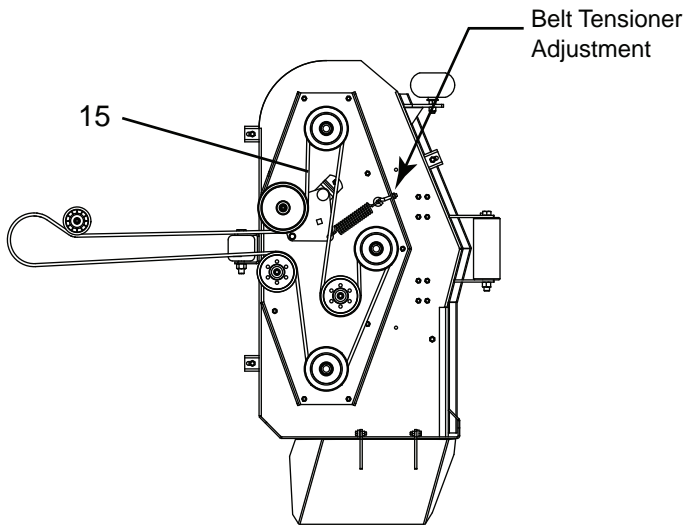

VIEWED FROM UNDER OF DECK

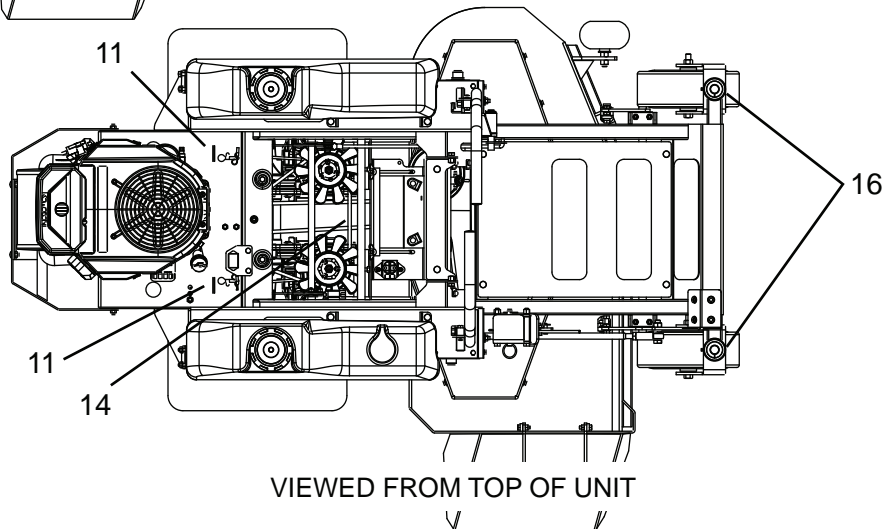

VIEWED FROM TOP OF UNIT

Figure 2

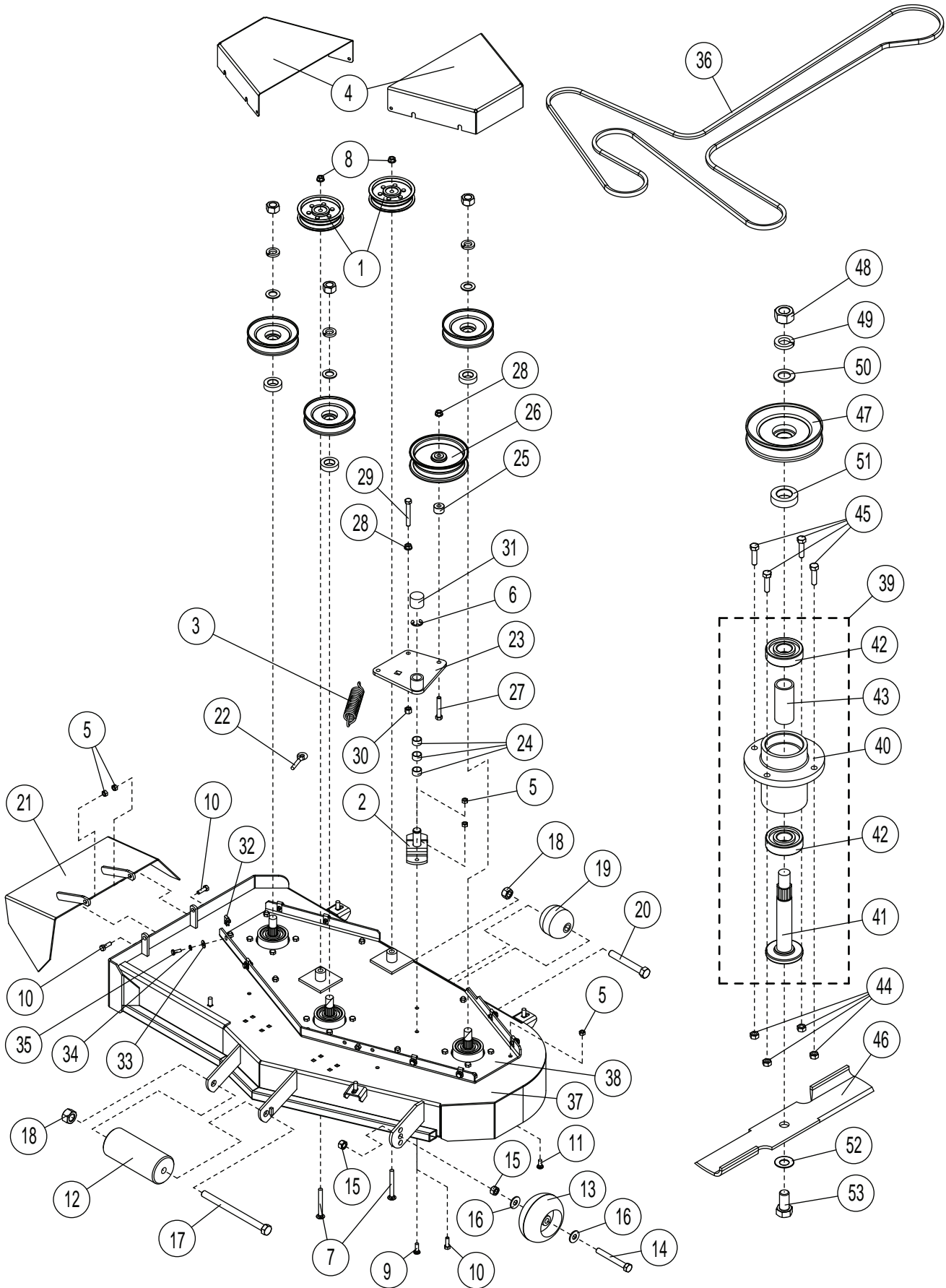



Deck Components

#	PART NUMBER	DESCRIPTION	QTY.
1	523329	FLOATING IDLER - FLAT	2
2	522104	OFFSET PIVOT	1
3	523327	FLOATING IDLER SPRING	1
4	353116	42 BELT SHIELD	2
5	104256	5/16-18 NYLOC NUT	34
6	108509	3/4 E-RING	1
7	107506	3/8-16 X 3-1/4 CARRIAGE BOLT	2
8	109007	3/8 - 16 WHIZ LOCK NUT	2
9	107509	5/16-18 X 1 CARR. BOLT	9
10	100273	5/16-18 X 1 HHCS	3
11	107503	5/16 - 18 X 3/4 CARR. HEAD	9
12	603023	FRONT ANT-SCALP ROLLER	1
13	423023	DECK ROLLER	1
14	100335	1/2-13 X 4 HHCS	1
15	104509	1/2-13 HEX NUT	2
16	105264	1/2 STD FLATWASHER	2
17	100351	5/8-11 X 8-1/2 HHCS	1
18	104261	5/8-11 HEX NUT	2
19	523084	REAR DECK ROLLER	1
20	100346	5/8-11 X 4-1/2 HHCS	1
21	582025	GRASS DEFLECTOR WLDMNT	1
22	363080	RIGHT EYEBOLT	1
23	352045	IDLER ARM W/BUSHINGS	1
24	363089	BRONZE BUSHINGS	3
25	823309	FRAME SPACER	1
26	533114	ENGAGEMENT IDLER	1
27	100297	3/8-16 X 2-1/4 HHCS	1
28	109007	3/8 - 16 WHIZ LOCK NUT	2
29	100299	3/8-16 X 2-3/4 HHCS	1
30	104257	3/8-16 NYLOC NUT	1
31	103009	CAPLUG 1-1/4	1
32	109015	1/4 - 20 NUT CLIP	8
33	105256	1/4 STD FLAT WASHER	8
34	105004	1/4 STD. LOCKWASHER	8
35	100252	1/4-20 X 3/4 HHCS	8
36	353114	42 DECK BELT	1
37	352036	42" DECK	1
38	352034	42 DECK PLATE	1
39	583106	BLADE SPINDLE ASSY	3



Deck Components

#	PART NUMBER	DESCRIPTION	QTY.
40	583111	SPINDLE HOUSING	3
41	583112	SPINDLE SHAFT	3
42	363350	BEARING - BLADE SPINDLE	6
43	583113	BEARING SPACER TUBE	3
44	104256	5/16-18 NYLOC NUT	12
45	100274	5/16-18 X 1-1/4 HHCS	12
46	423029	14.25 HIGH LIFT BLADE	3
47	423262	5" HEX PULLEY	3
48	104511	3/4-16 HEX NUT	3
49	105010	3/4 LOCK WASHER	3
50	105269	3/4 SAE FLAT WASHER	3
51	583110	PULLEY SPACER	3
52	583108	5/8 DISC SPRING WASHER	3
53	100355	5/8-11 X 1-1/4 HHCS	3

NOTE:



Deck Lift Components

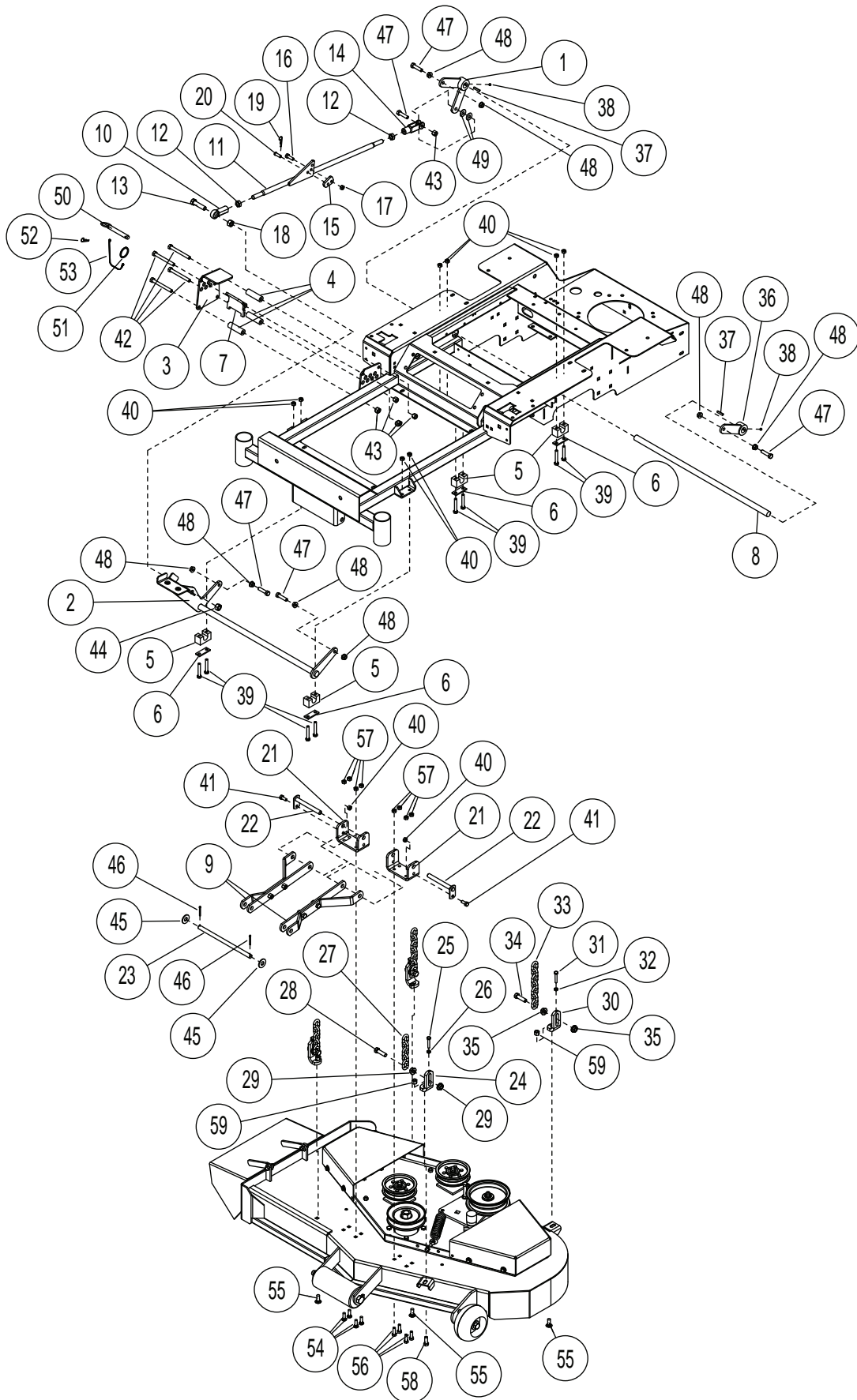



Deck Lift Components

#	PART NUMBER	DESCRIPTION	QTY.
1	352010	REAR LIFT BELLCRANK, RT	1
2	352014	FRONT LIFT SHAFT	1
3	353043	HEIGHT PLATE, OUTER	1
4	353040	HEIGHT PLATE SPACER	3
5	353028	PIVOT BLOCK	4
6	353047	PIVOT BLOCK PLATE	4
7	352018	TRANSPORT LATCH	1
8	533010	LIFT SHAFT- FRONT	1
9	-----	STRUT ASM. (ORDER ITEM 60,61)	2
10	533084	ROD END 1/2"	1
11	352028	CONNECTING ROD	1
12	104755	1/2-20 HEX JAM NUT	2
13	100329	1/2-13 X 2 HHCS	1
14	533083	CLEVIS END 1/2"	1
15	353038	HEIGHT ADJUST TAB	1
16	100273	5/16-18 X 1 HHCS	1
17	104256	5/16-18 NYLOC NUT	1
18	104509	1/2-13 HEX NUT	1
19	363165	#3 HAIRPIN COTTOR	1
20	363144	CLEVIS PIN 5/16	1
21	353045	STRUT MOUNT	2
22	352032	REAR STRUT PIVOT PIN	2
23	353110	FRONT STRUT PIN	1
24	533112	ADJUSTABLE CHAIN MT.	2
25	100006	1/4-20 X 1.5 HH TAP BOLT	2
26	104758	1/4-20 HEX JAM NUT	2
27	423359	FRONT CHAIN	2
28	100311	7/16-14 X 1-1/2 HHCS	2
29	109027	7/16-14 WHIZLOCK NUT	4
30	533112	ADJUSTABLE CHAIN MT.	2
31	100006	1/4-20 X 1.5 HH TAP BOLT	2
32	104758	1/4-20 HEX JAM NUT	2
33	423360	REAR CHAIN	2
34	100311	7/16-14 X 1-1/2 HHCS	2
35	109027	7/16-14 WHIZLOCK NUT	4
36	352012	REAR LIFT BELLCRANK, LT	1
37	107255	3/16 X 3/16 X 1 MACHINE KEY	2
38	103292	1/4-28 SETSCREW	2
39	100277	5/16-18 X 2 HHCS	8



Deck Lift Components

#	PART NUMBER	DESCRIPTION	QTY.
40	104256	5/16-18 NYLOC NUT	10
41	100271	5/16-18 X 3/4 HHCS	2
42	100302	3/8-16 X 3-1/2 HHCS	4
43	104257	3/8-16 NYLOC NUT	5
44	104259	1/2-13 NYLOCK NUT	1
45	105264	1/2 STD FLATWASHER	2
46	106763	1/2 X 1 1/4 COTTER PIN	2
47	100294	3/8-16 X 1-1/2 HHCS	5
48	109007	3/8 - 16 WHIZ LOCK NUT	8
49	105260	3/8 STD FLAT WASHER	2
50	353153	1/2 X 3 RING PIN	1
51	109002	1-1/2 O.D. SPLIT RING	1
52	153025	# 4 HAIRPIN COTTER - PLTD.	1
53	123012	SAFETY CHAIN	1
54	107509	5/16-18 X 1 CARR. BOLT	4
55	107526	1/4-20 X 3/4" CARR BOLT	3
56	100273	5/16-18 X 1 HHCS	4
57	104256	5/16-18 NYLOC NUT	8
58	100292	3/8-16 X 1 HHCS	1
59	104257	3/8-16 NYLOC NUT	4
60	353050	STRUT BENT	2
61	353052	STRUT STRAIGHT	2

NOTE:



Frame Components

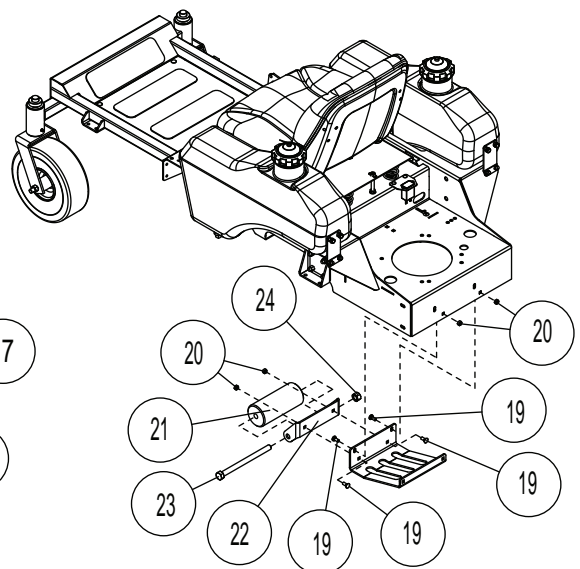
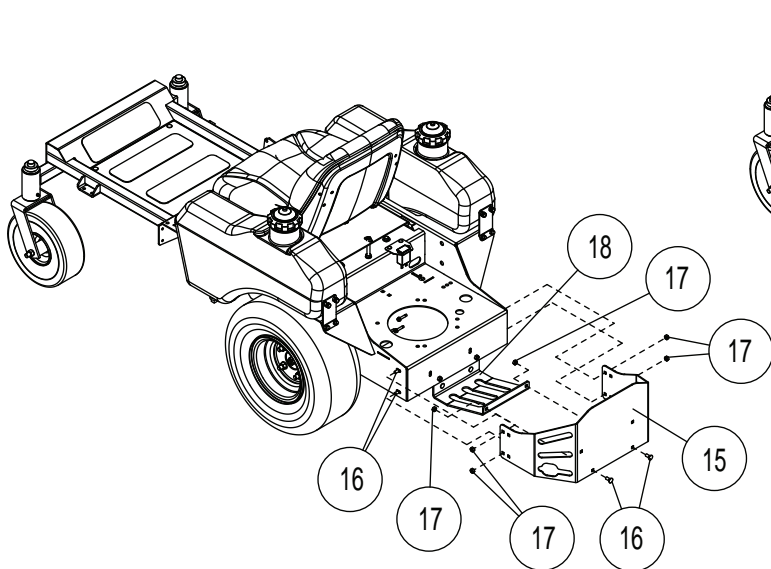
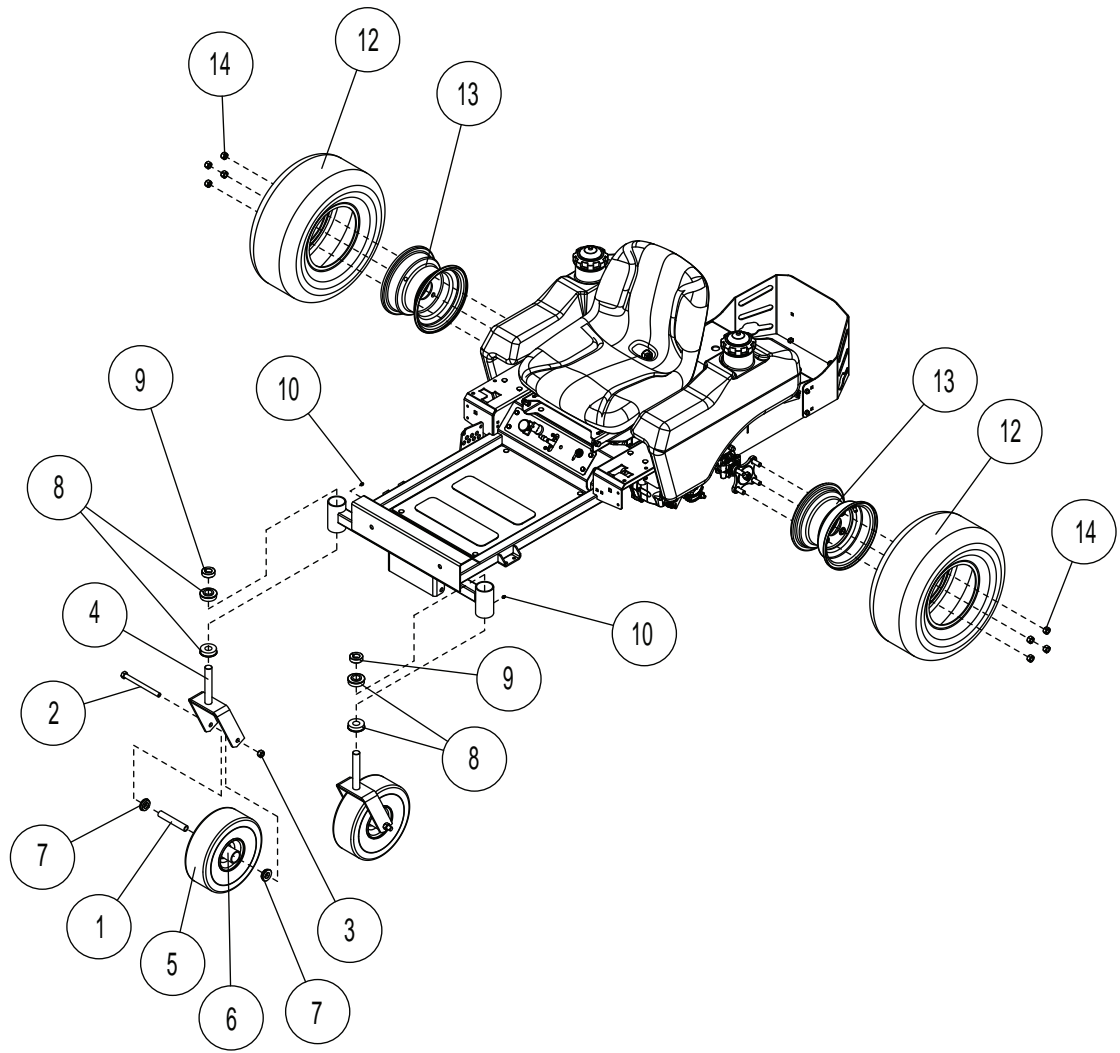



Frame Components

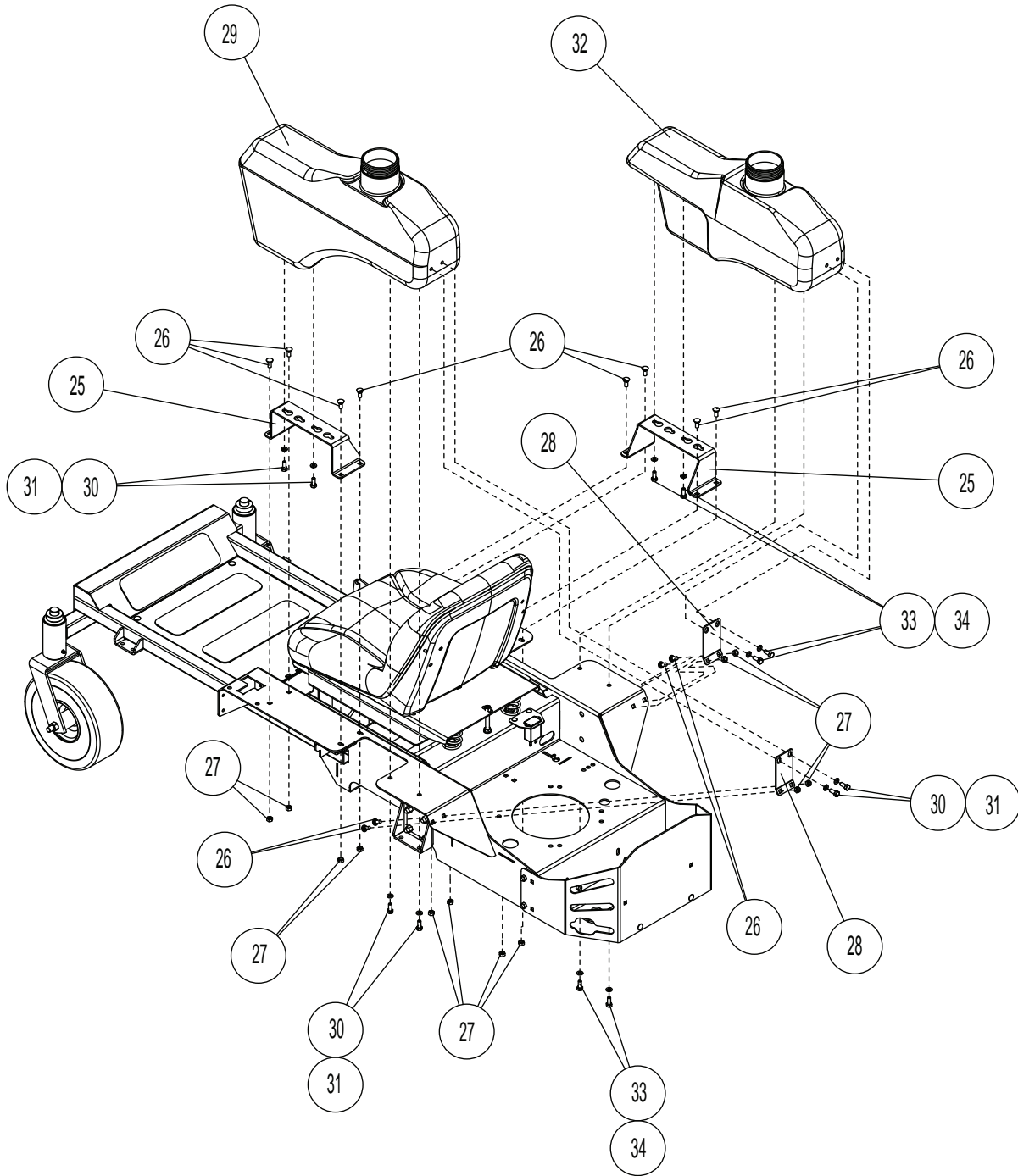



Frame Components

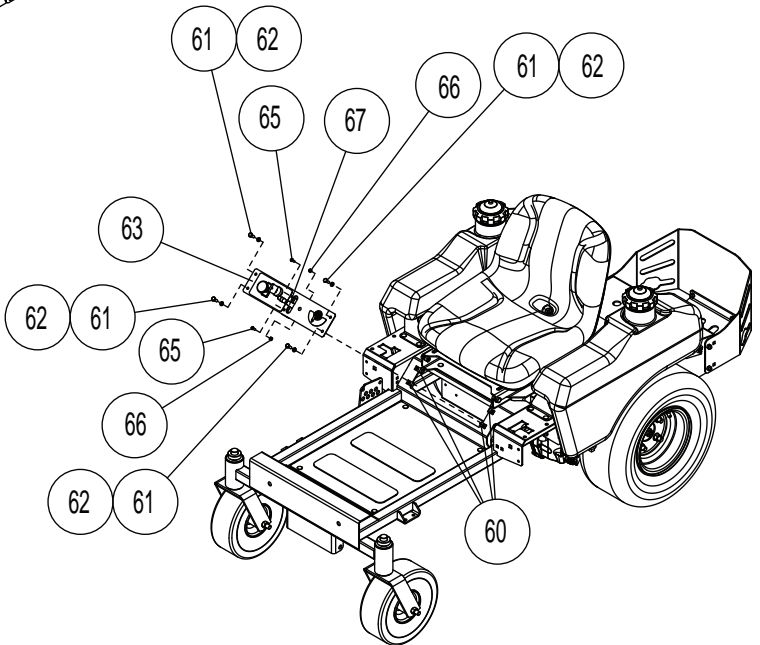
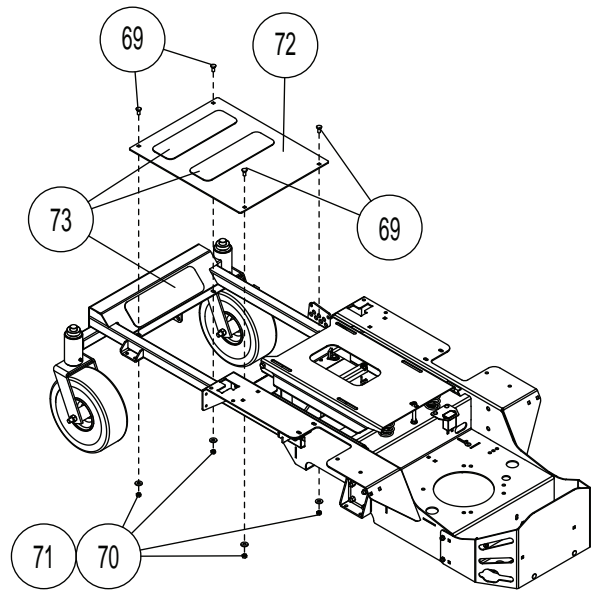
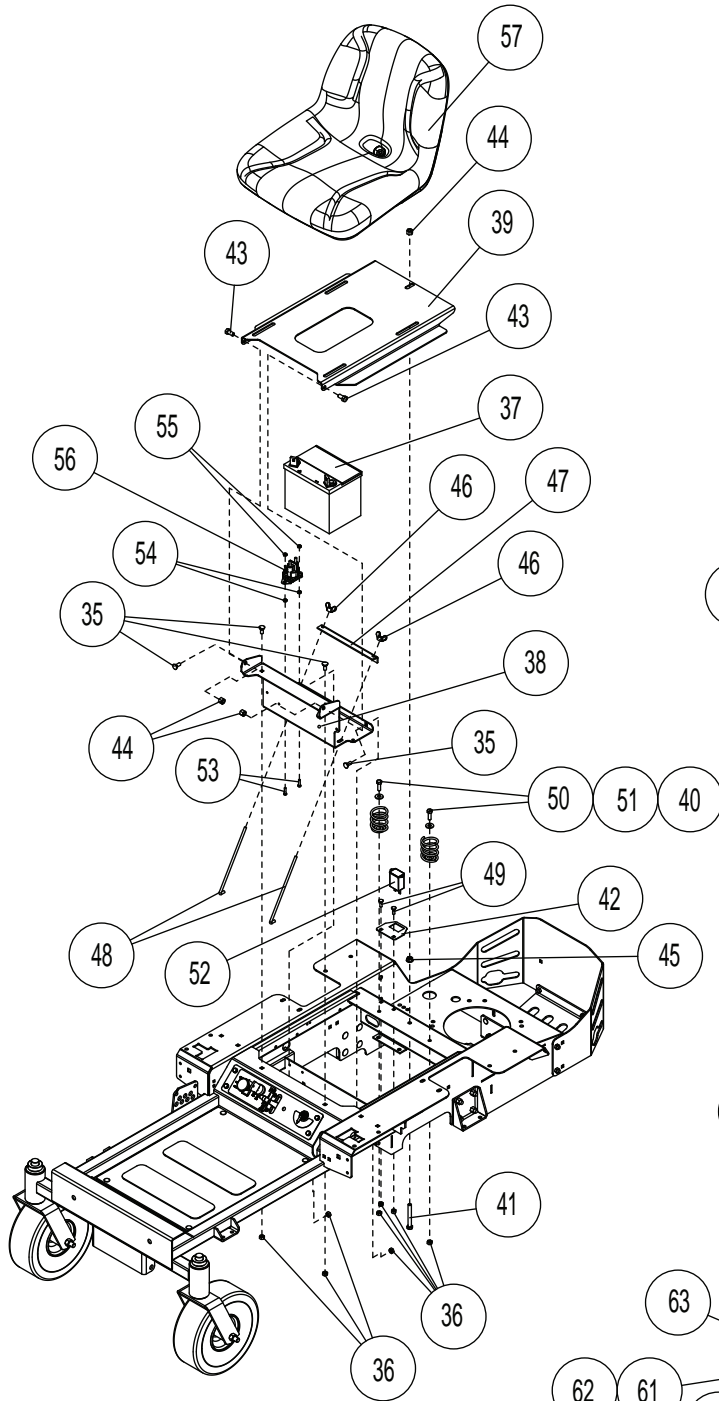



Frame Components

#	PART NUMBER	DESCRIPTION	QTY.
1	363307	AXLE TUBE	2
2	100339	1/2-13 X 6 HHCS	2
3	104259	1/2-13 NYLOCK NUT	2
4	422016	FRONT CASTER YOKE WELDMENT	2
5	363260	FRONT TIRE W/TUBE (4.10 X 3.50 X 4)	2
6	363311	FRONT CASTER COMPLETE	2
--	-----	FRONT RIM NOT SERVICED	2
7	423201	BEARING RETAINER	2
8	423109	7/8 FLANGE BEARING	4
9	423071	7/8 CLAMP COLLAR	2
10	111001	1/8 NPT STRAIGHT	2
11	353126	18 X 9.50 - 8 TIRE ASM. (NOT SHOWN)	2
12	353148	DRIVE TIRE (18 X 9.5 X 8)	2
13	353149	RIM W/VALVESTEM	2
14	103023	1/2-20 LUG NUT	8
15	353075	ENGINE GUARD	1
16	107503	5/16 - 18 X 3/4 CARR. HEAD	6
17	104256	5/16-18 NYLOC NUT	6
18	353100	SKID PLATE	1
19	107503	5/16 - 18 X 3/4 CARR. HEAD	6
20	104256	5/16-18 NYLOC NUT	6
21	603023	FRONT ANT-SCALP ROLLER	1
22	353145	WHEELIE BAR	1
23	100351	5/8-11 X 8-1/2 HHCS	1
24	104261	5/8-11 HEX NUT	1
<i>Items 1 thru 24 shown on page D-1</i>			
25	353067	TANK SUPPORT	2
26	107503	5/16 - 18 X 3/4 CARR. HEAD	18
27	104256	5/16-18 NYLOC NUT	17
28	353085	REAR TANK MOUNT	2
29	SEE FUEL SECTION	LH FUEL TANK	1
30	100271	5/16-18 X 3/4 HHCS	1
31	105005	5/16 LOCK WASHER	1
32	SEE FUEL SECTION	RH FUEL TANK	1
33	100271	5/16-18 X 3/4 HHCS	1
34	105005	5/16 LOCK WASHER	1
<i>Items 25 thru 34 shown on page D-2</i>			
35	107503	5/16 - 18 X 3/4 CARR. HEAD	22
36	104256	5/16-18 NYLOC NUT	17
37	423142	BATTERY	1
38	353011	BATTERY TRAY	1
39	353015	SEAT PAN	1



Frame Components

#	PART NUMBER	DESCRIPTION	QTY.
40	523278	SEAT SPRING	2
41	100030	3/8-16 X 3 HHTB	1
42	353083	HOUR METER MOUNT	1
43	100291	3/8-16 X 3/4 HHCS	2
44	104257	3/8-16 NYLOC NUT	2
45	109007	3/8 - 16 WHIZ LOCK NUT	1
46	109012	1/4 WING NUT	2
47	423011	HOLD DOWN ANGLE	1
48	423172	BATTERY HOLD DOWN	2
49	107502	1/4-20 X 3/4 CARR. BOLT	2
50	100273	5/16-18 X 1 HHCS	2
51	105258	5/16 STD FLAT WASHER	2
52	523283	HOUR METER	1
53	109009	#10-24 X .75 HHS	2
54	109006	#10 WHIZLOCK NUT	2
55	104252	#10-24 NYLOC NUT	2
56	422150	STARTER RELAY - WP	1
57	353098	SEAT COMPLETE W/O TRACKS	1
58	593097	MOLDED ARM REST (NOT SHOWN)	-
59	353048	SEAT SWITCH (NOT SHOWN)	1
60	109015	1/4 - 20 NUT CLIP	4
61	100252	1/4-20 X 3/4 HHCS	4
62	105004	1/4 STD. LOCKWASHER	4
63	353177	CONSOLE PLATE W/CHOKE	1
64	523031	PTO SWITCH (NOT SHOWN)	1
65	101039	#10-24 X 5/8 PAN HD. SCREW	2
66	104252	#10-24 NYLOC NUT	2
67	363352	THROTTLE CONTROL CONSOLE	1
68	423027	IGNITION SWITCH (NOT SHOWN)	1
69	107503	5/16 - 18 X 3/4 CARR. HEAD	22
70	104256	5/16-18 NYLOC NUT	17
71	105258	5/16 STD FLAT WASHER	2
72	353079	FLOOR PAN	1
73	423302	Z-STEP TREAD	3

Items 35 thru 73 shown on page D-3

NOTE:

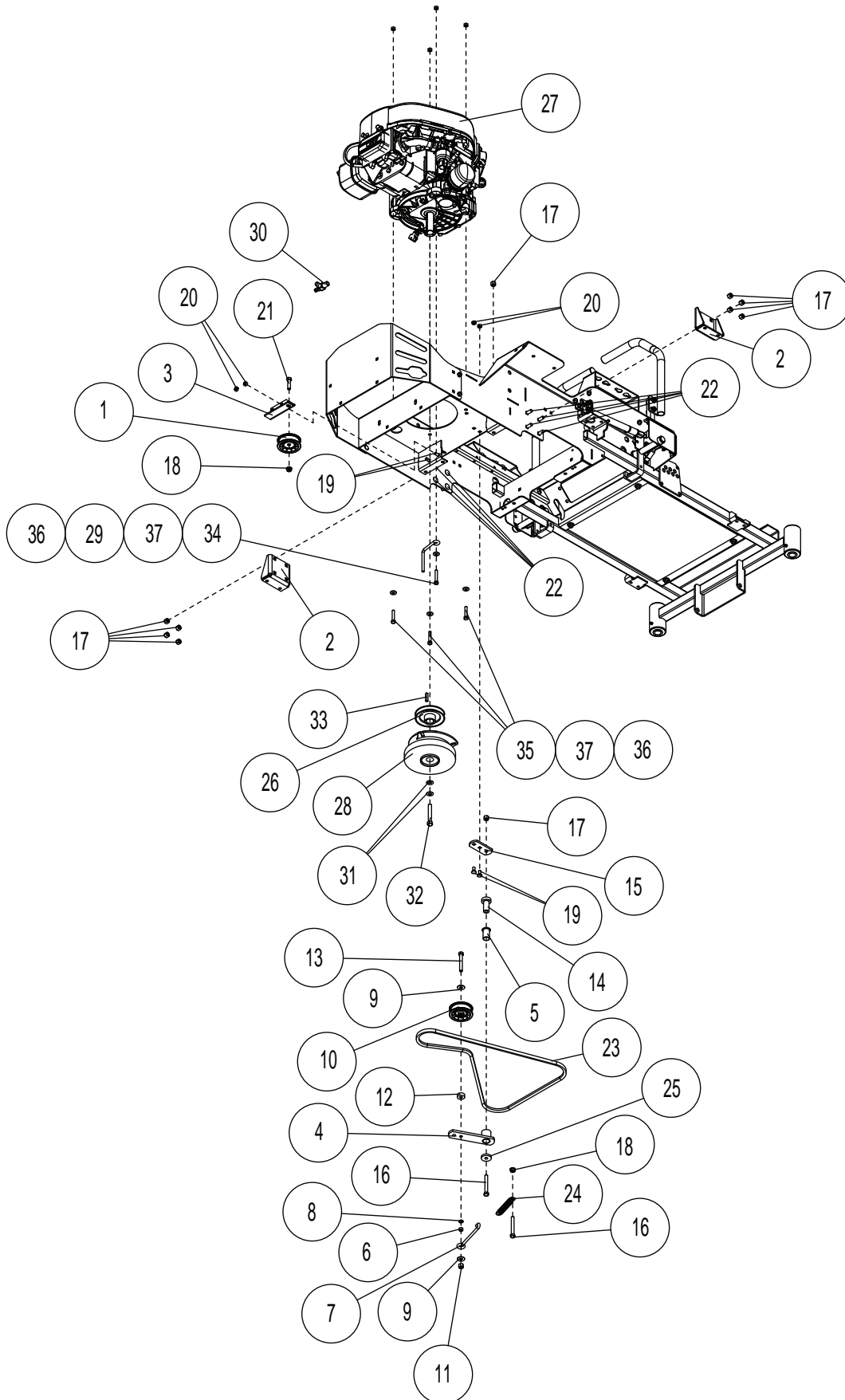



Drive Components

#	PART NUMBER	DESCRIPTION	QTY.
1	823351	PUMP DRIVE IDLER	1
2	352026	AXLE SUPPORT	2
3	353087	IDLER MOUNT	1
4	422025	TENSIONER W/BUSHING	1
5	523111	3/4 PLASTIC BUSHING	1
6	363174	EYE BOLT SPACER	1
7	423122	PUMP TENSION ROD	1
8	105005	3/8 LOCK WASHER	1
9	105260	3/8 STD FLAT WASHER	2
10	823351	PUMP DRIVE IDLER	1
11	104257	3/8-16 NYLOC NUT	1
12	483017	RH IDLER SPACER	1
13	100299	3/8-16 X 2-3/4 HHCS	1
14	423175	IDLER PIVOT	1
15	353089	PUMP IDLER MOUNT	1
16	100300	3/8-16 X 3 HHCS	2
17	104257	3/8-16 NYLOC NUT	10
18	109007	3/8 - 16 WHIZ LOCK NUT	2
19	107503	5/16 - 18 X 3/4 CARR. HEAD	4
20	104256	5/16-18 NYLOC NUT	4
21	100294	3/8-16 X 1-1/2 HHCS	1
22	107526	1/4-20 X 3/4" CARR BOLT	8
23	353112	PUMP BELT	1
24	553007	IDLER SPRING	1
25	373089	RETAINING WASHER	1
26	353101	PULLEY	1
27	-----	17HP KAWASAKI ELECTRIC FH54V-BS31R	1
28	423285	CLUTCH	1
29	373070	BELT GUIDE - LONG	1
30	423406	OIL DRAIN VALVE 3/8 NPT	1
31	423069	7/16 DISC SPRING WASHER	2
32	100536	5/8-11 X 7 HHCS	1
33	107260	1/4 X 1/4 X 1.25	1
34	100277	5/16-18 X 2 HHCS	1
35	100276	5/16-18 X 1-3/4 HHCS	3
36	104256	5/16-18 NYLOC NUT	6
37	363226	5/16 DISC SPRING WASHER	4

NOTE:



Control Components - Right Hand

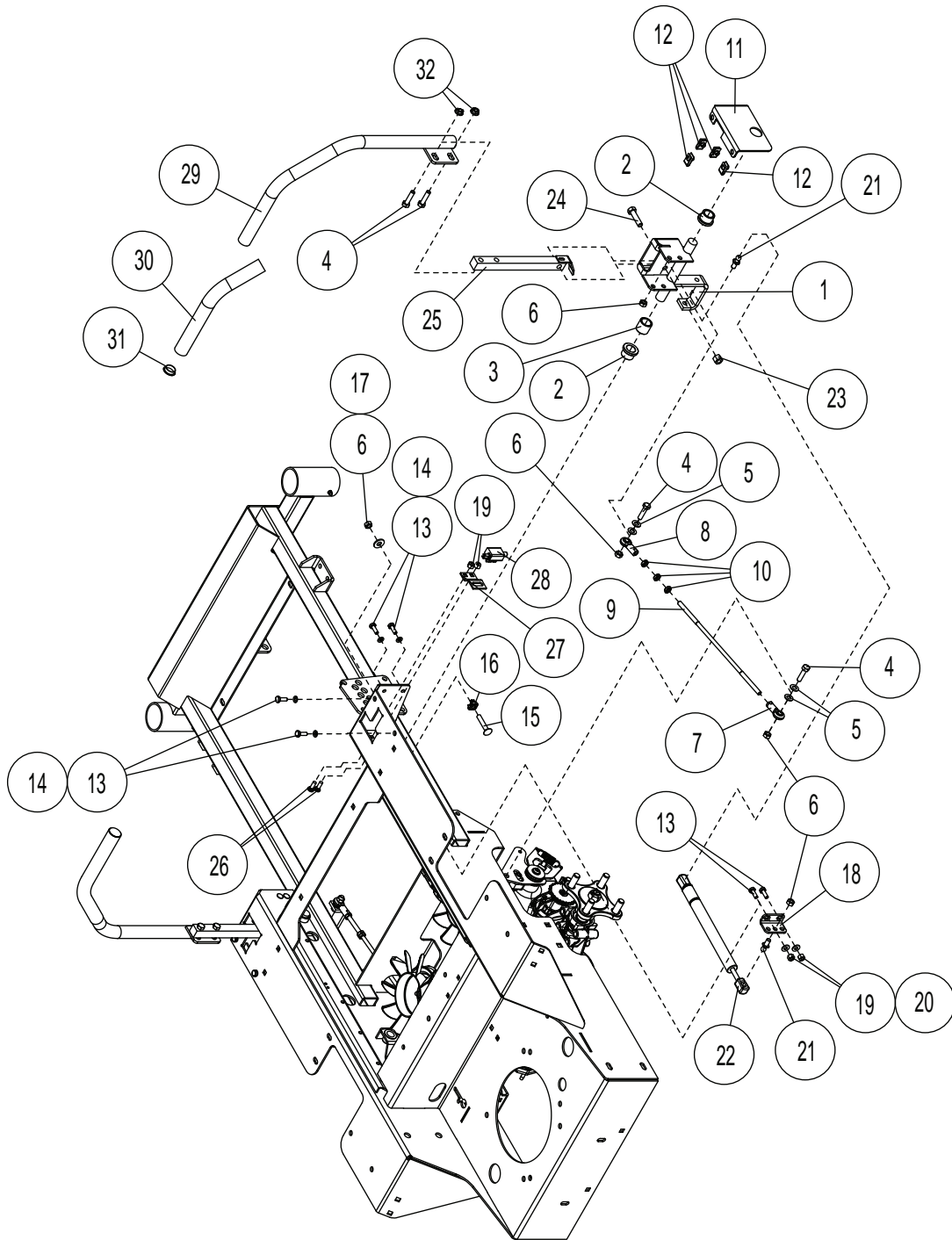

ITEM 7

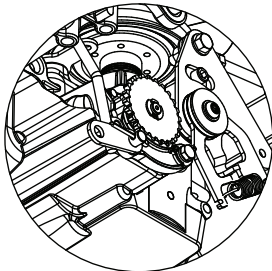

MOUNTING VIEW

ITEM 8

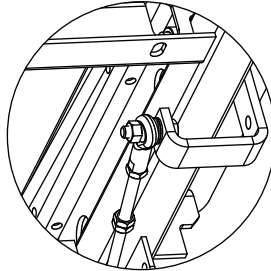

MOUNTING VIEW

ITEM 18

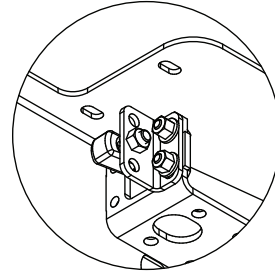

MOUNTING VIEW



Control Components - Right Hand

#	PART NUMBER	DESCRIPTION	QTY.
1	352004	STEERING CONTROL RT	1
2	353018	3/4" FLANGE BEARING	2
3	353024	DRIVE CONTROL SPACER	1
4	100274	5/16-18 X 1-1/4 HHCS	8
5	105257	5/16 SAE FLATWASHER	8
6	104256	5/16-18 NYLOC NUT	13
7	623095	5/16 LH ROD END (F)	2
8	453081	.312 ROD END (F)	2
9	353093	DRIVE LINKAGE	2
10	104752	5/16-24 JAM NUT	6
11	353061	RT CONTROL BRACKET	1
12	109015	1/4 - 20 NUT CLIP	4
13	100252	1/4-20 X 3/4 HHCS	6
14	105004	1/4 STD. LOCKWASHER	4
15	107520	5/16-18 X 1-3/4 TAP CARR. BOLT	1
16	353151	5/16-18 SQ. CAGE NUT	1
17	105258	5/16 STD FLAT WASHER	1
18	353143	DAMPENER MOUNT	1
19	104255	1/4-20 NYLOC NUT	6
20	105255	1/4" SAE WASHER	2
21	823221	10MM BALL STUD	2
22	583415	DAMPENER / CONTROL	1
23	104257	3/8-16 NYLOC NUT	1
24	100294	3/8-16 X 1-1/2 HHCS	1
25	352008	HANDLE MOUNT	1
26	107502	1/4-20 X 3/4 CARR. BOLT	2
27	353021	SWITCH BRACKET	1
28	593041	NEUTRAL SWITCH	1
29	592041	HANDLE RH W / GRIP	1
30	523032	HANDLE GRIP	1
31	523033	HANDLE PLUG	1
32	109001	5/16-18 WHIZLOCK NUT	2

NOTE:



Control Components - Left Hand

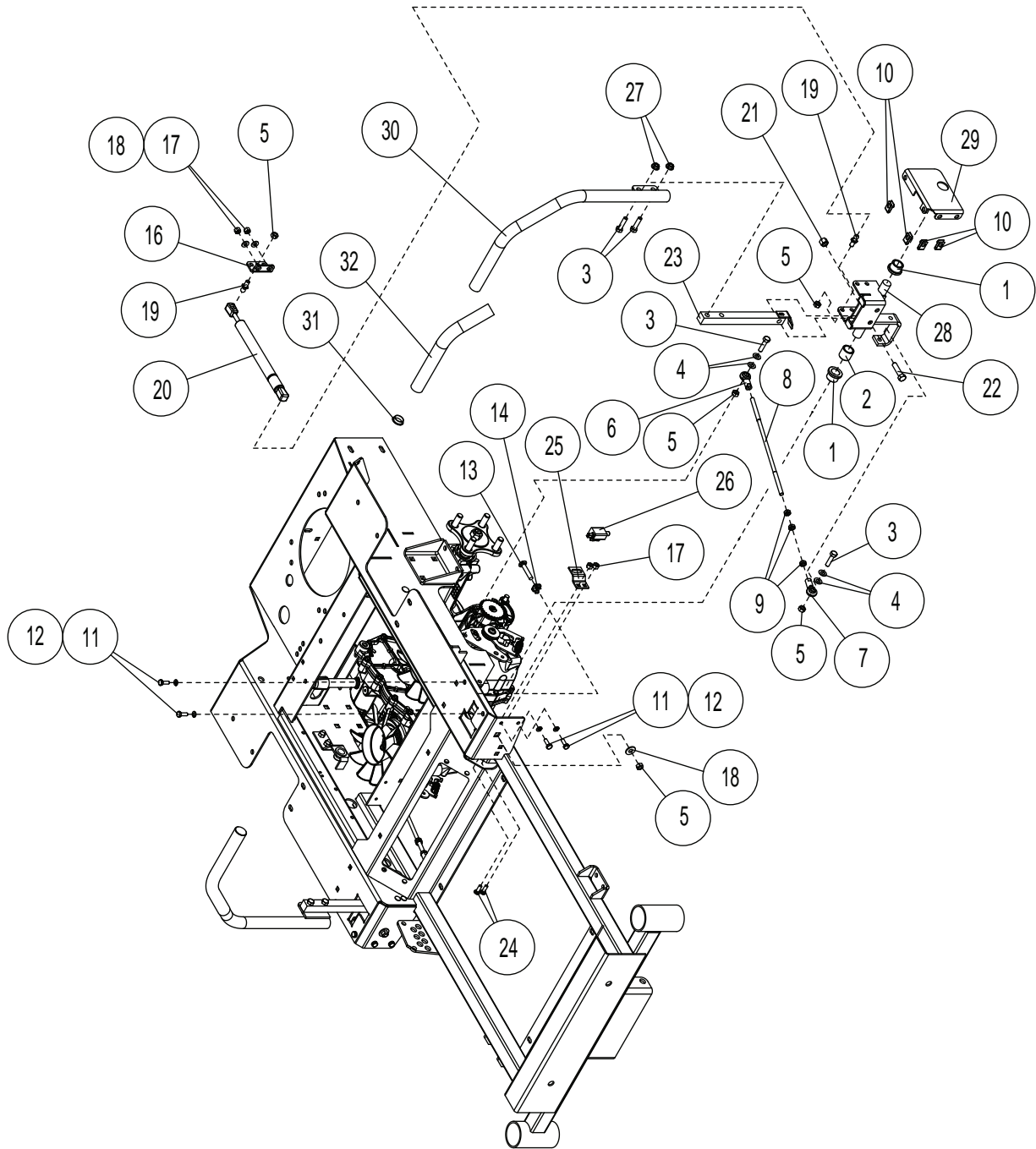

ITEM 7

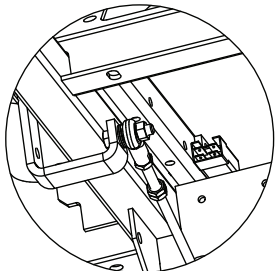

MOUNTING VIEW

ITEM 6

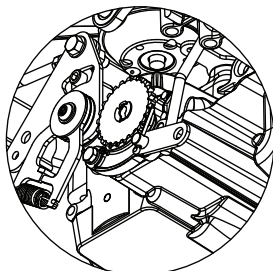

MOUNTING VIEW

ITEM 16

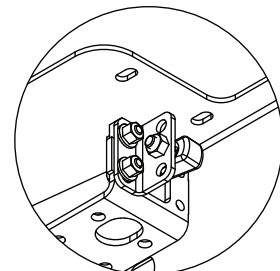

MOUNTING VIEW



Control Components - Left Hand

#	PART NUMBER	DESCRIPTION	QTY.
1	353018	3/4" FLANGE BEARING	2
2	353024	DRIVE CONTROL SPACER	1
3	100274	5/16-18 X 1-1/4 HHCS	8
4	105257	5/16 SAE FLATWASHER	8
5	104256	5/16-18 NYLOC NUT	11
6	623095	5/16 LH ROD END (F)	2
7	453081	.312 ROD END (F)	2
8	353093	DRIVE LINKAGE	2
9	104752	5/16-24 JAM NUT	6
10	109015	1/4 - 20 NUT CLIP	4
11	100252	1/4-20 X 3/4 HHCS	6
12	105004	1/4 STD. LOCKWASHER	4
13	107520	5/16-18 X 1-3/4 TAP CARR. BOLT	1
14	353151	5/16-18 SQ. CAGE NUT	1
15	105258	5/16 STD FLAT WASHER	1
16	353143	DAMPENER MOUNT	2
17	104255	1/4-20 NYLOC NUT	4
18	105255	1/4" SAE WASHER	2
19	823221	10MM BALL STUD	2
20	583415	DAMPENER / CONTROL	1
21	104257	3/8-16 NYLOC NUT	1
22	100294	3/8-16 X 1-1/2 HHCS	1
23	352008	HANDLE MOUNT	1
24	107502	1/4-20 X 3/4 CARR. BOLT	2
25	353021	SWITCH BRACKET	1
26	593041	NEUTRAL SWITCH	1
27	109001	5/16-18 WHIZLOCK NUT	4
28	352006	STEERING CONTROL LT	1
29	353063	LT CONTROL BRACKET	1
30	592042	HANDLE LH W / GRIP	1
31	523033	HANDLE PLUG	1
32	523032	HANDLE GRIP	1

NOTE:



Brake Components - Right Hand

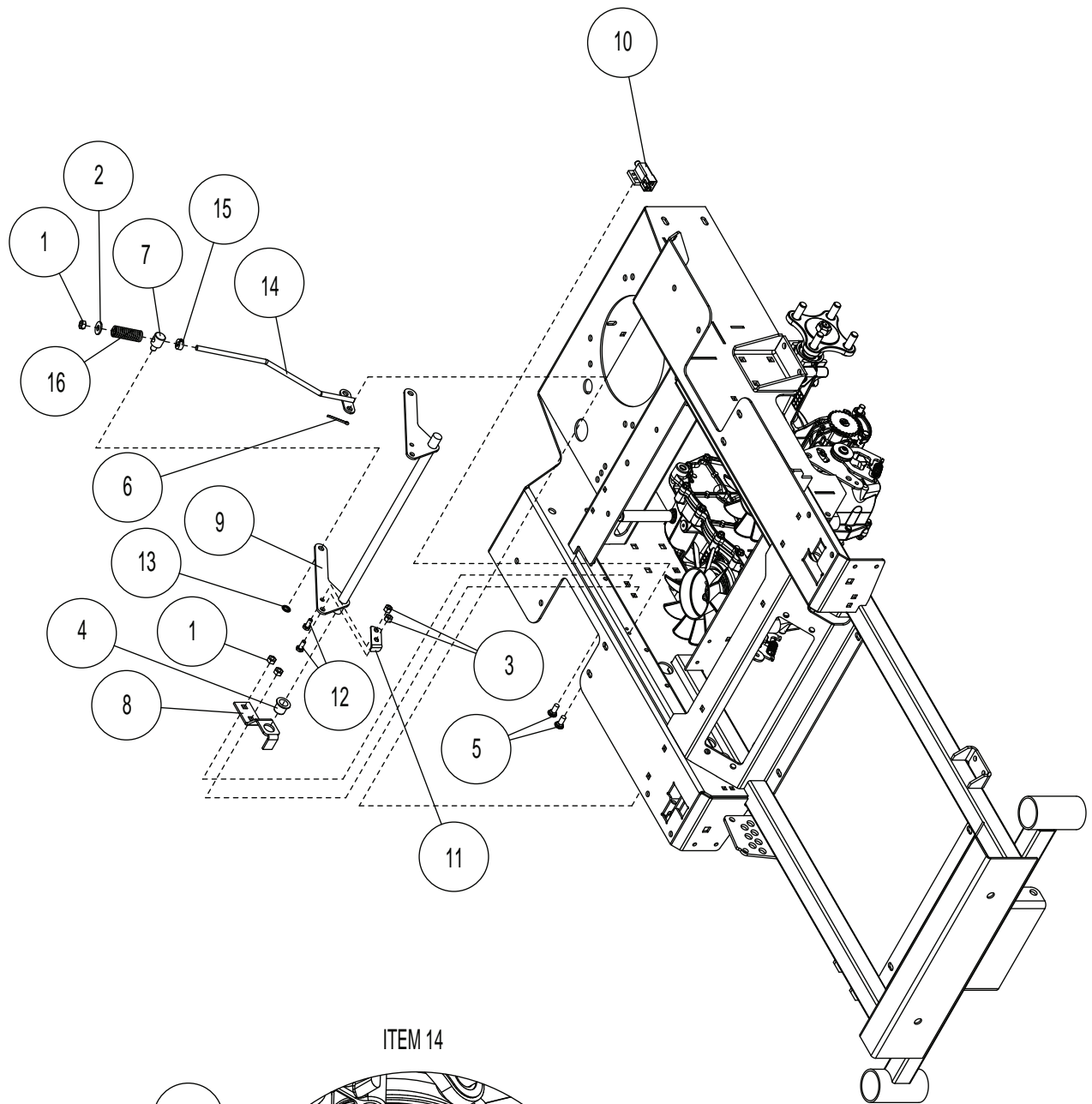

ITEM 14

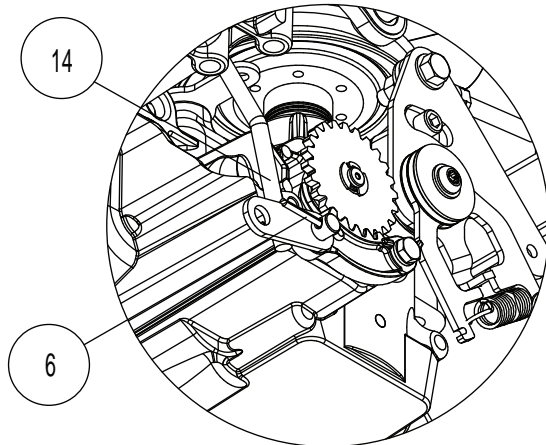

MOUNTING VIEW



Brake Components - Right Hand

#	PART NUMBER	DESCRIPTION	QTY.
1	104256	5/16-18 NYLOC NUT	4
2	105258	5/16 STD FLAT WASHER	1
3	104255	1/4-20 NYLOC NUT	2
4	353057	5/8 FLANGE BUSHING	1
5	107503	5/16 - 18 X 3/4 CARR. HEAD	2
6	106763	1/2 X 1 1/4 COTTER PIN	1
7	423130	PARK BRAKE SWIVEL	1
8	353059	BRAKE SHAFT MOUNT	1
9	352020	BRAKE SHAFT	1
10	523034	PARK BRAKE SWITCH	1
11	353073	BRAKE SWITCH ACTUATOR	1
12	100251	1/4-20 X 5/8 HHCS	2
13	363177	3/8 PUSH NUT	1
14	352042	LOWER BRAKE LINKAGE	1
15	523112	5/16 CLAMP COLLAR	1
16	523024	SPRING	1

NOTE:



Brake Components - Left Hand

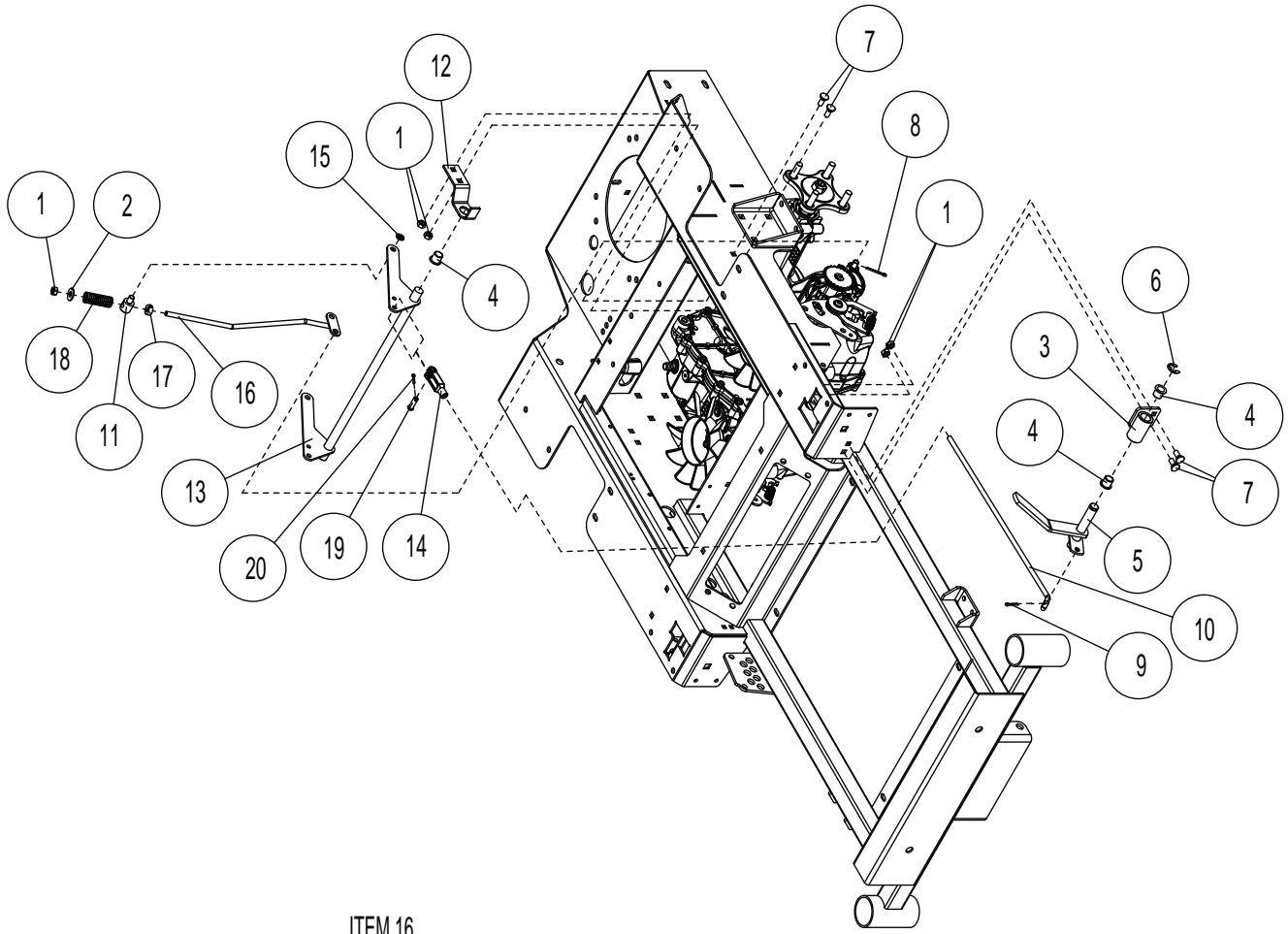

ITEM 16

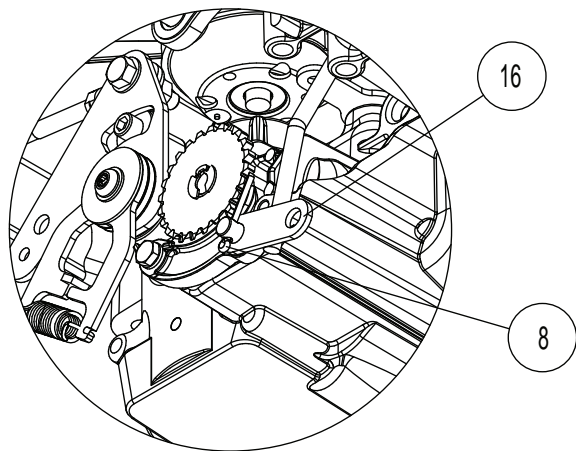

MOUNTING VIEW



Brake Components - Left Hand

#	PART NUMBER	DESCRIPTION	QTY.
1	104256	5/16-18 NYLOC NUT	6
2	105258	5/16 STD FLAT WASHER	1
3	352024	BRAKE LEVER PIVOT	1
4	353057	5/8 FLANGE BUSHING	3
5	352022	BRAKE LEVER	1
6	108500	E-RING FOR 5/8 DIA	1
7	107503	5/16 - 18 X 3/4 CARR. HEAD	4
8	106763	1/2 X 1 1/4 COTTER PIN	2
9	106753	3/32 X 3/4 COTTER PIN	1
10	353071	BRAKE LINKAGE	1
11	423130	PARK BRAKE SWIVEL	1
12	353059	BRAKE SHAFT MOUNT	1
13	352020	BRAKE SHAFT	1
14	363152	YOKE 5/16-24	1
15	363177	3/8 PUSH NUT	1
16	352042	LOWER BRAKE LINKAGE	2
17	523112	5/16 CLAMP COLLAR	1
18	523024	SPRING	1
19	363144	CLEVIS PIN 5/16	1
20	106763	COTTER PIN 1/8 X 3/4	1

NOTE:

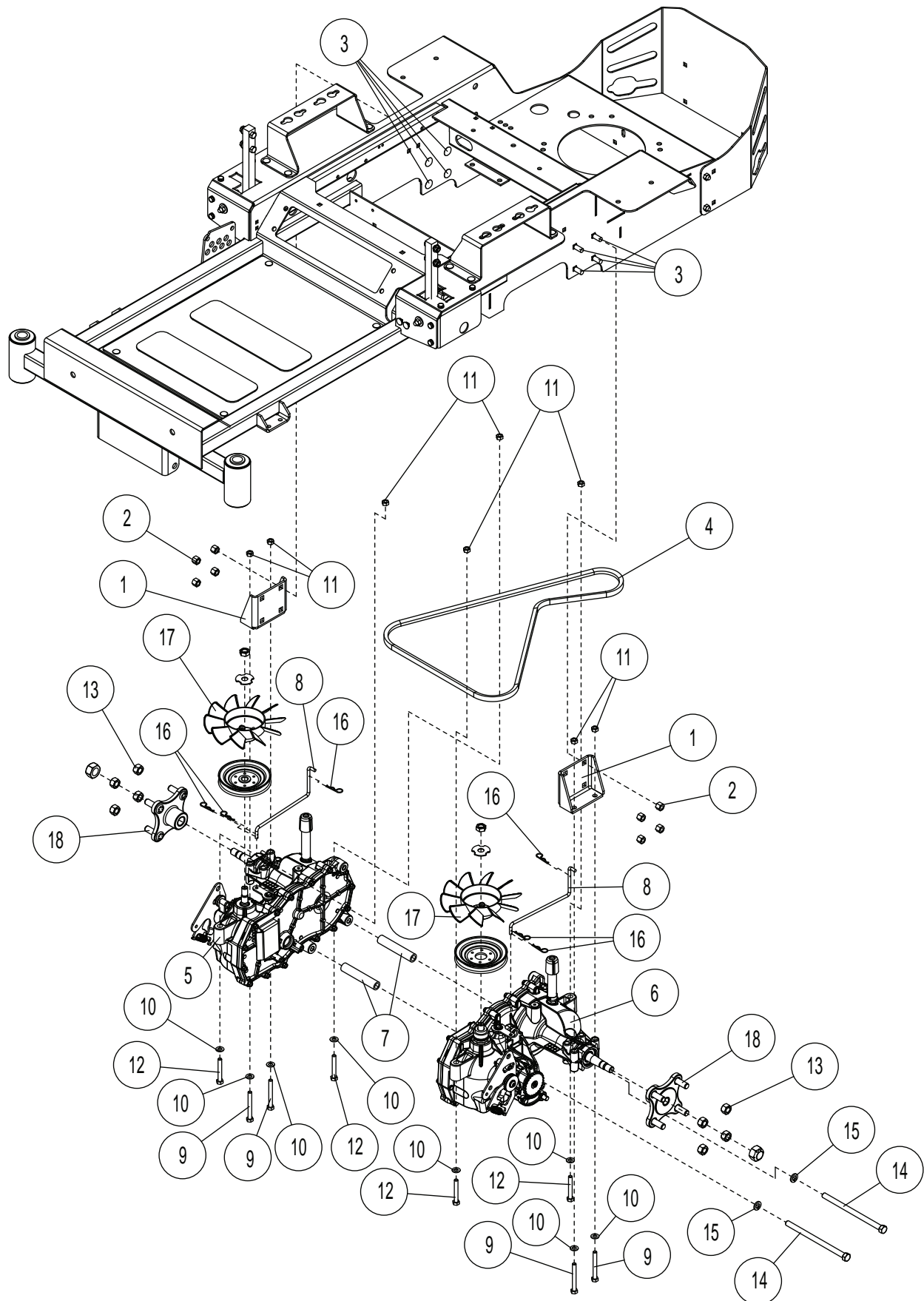



Hydro Components

#	PART NUMBER	DESCRIPTION	QTY.
1	353013	AXLE MOUNT	1
2	104257	3/8-16 NYLOC NUT	20
3	107526	1/4-20 X 3/4" CARR BOLT	8
4	353112	PUMP BELT	1
5	353127	EZT RH	1
6	353128	EZT LH	1
7	353118	TIE ROD	2
8	353091	BYPASS LINKAGE	2
9	100280	5/16-18 X 2-1/2 HHCS	4
10	105257	5/16 SAE FLATWASHER	16
11	104256	5/16-18 NYLOC NUT	12
12	100278	5/16-18 X 2-1/2 HHCS	4
13	103023	1/2-20 LUG NUT	8
14	100321	7/16-14 X 7.0 HHCS	2
15	105007	7/16 ANSI STD LOCK WASHER	2
16	363165	#3 HAIRPIN COTTOR	6
17	353189	FAN - SERVICE PART	-
18	353190	HUB - SERVICE PART (HYDROGEAR# 71093)	-

NOTE:



Fuel Components

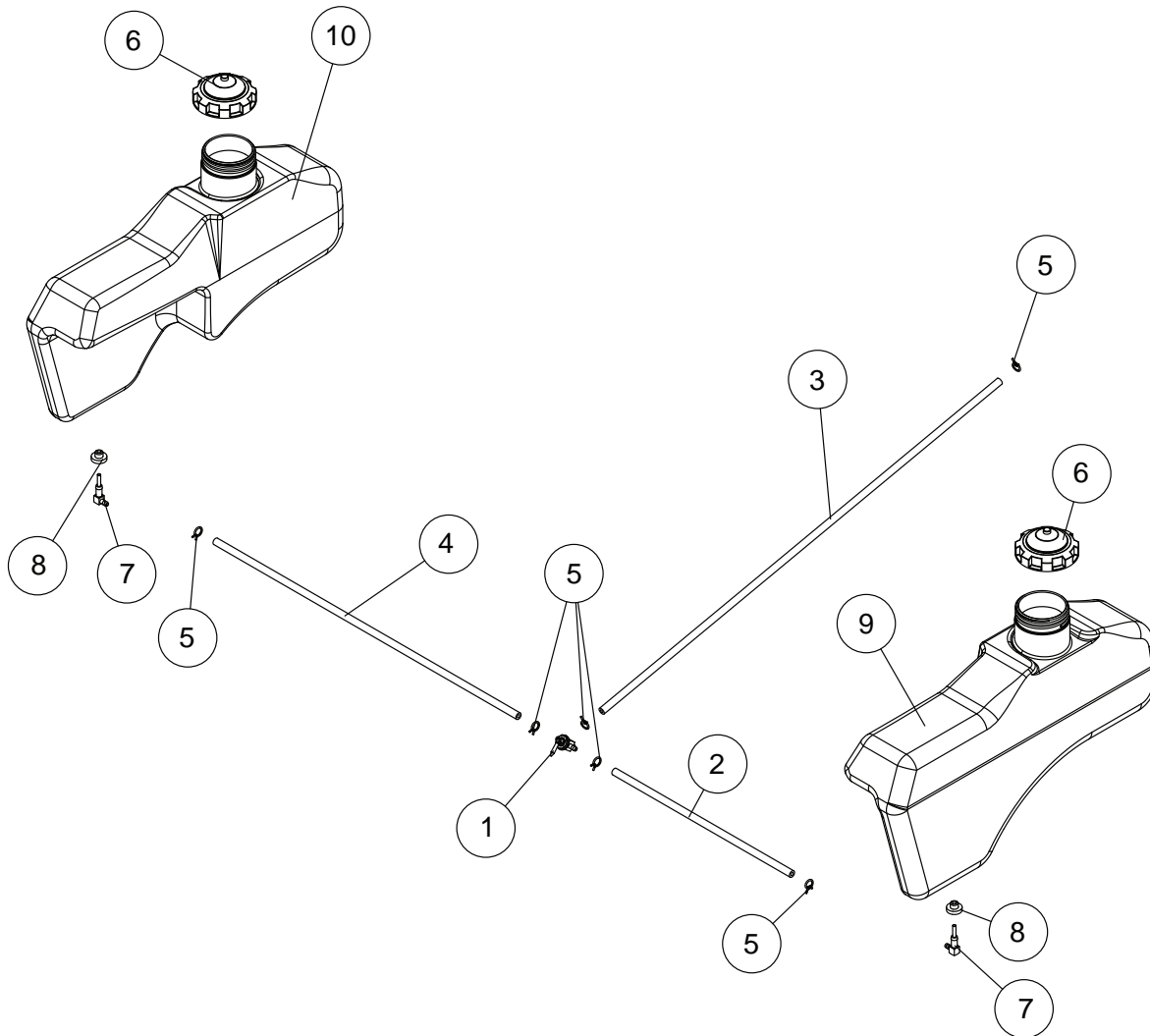

#	PART NO.	DESCRIPTION	QTY.
1	583050	FUEL VALVE	1
2	363099	FUEL LINE - 17"	1
3	583185	FUEL LINE - 39"	1
4	823315	FUEL LINE - 27"	1
5	363098	FUEL LINE CLAMP	6
6	823179	FUEL CAP - LARGE	2
7	583183	FUEL TANK ADAPTER	2
8	533125	VALVE GROMMET	2
9	353156	LH FUEL TANK	1
10	353155	RH FUEL TANK	1

NOTE:

- A:** THERE ARE NO REPLACEMENT DECALS FOR TANKS, BECAUSE THEY ARE MOLDED INTO THE TANK.



Electrical Section

ENCORE PART # 353132
WIRE HARNESS FOR F42K17 ; 17 HP KAWASAKI
ENCORE PART #353180
KAW. WIRING PIGTAIL FOR F42K17 ; 17 HP KAWASAKI

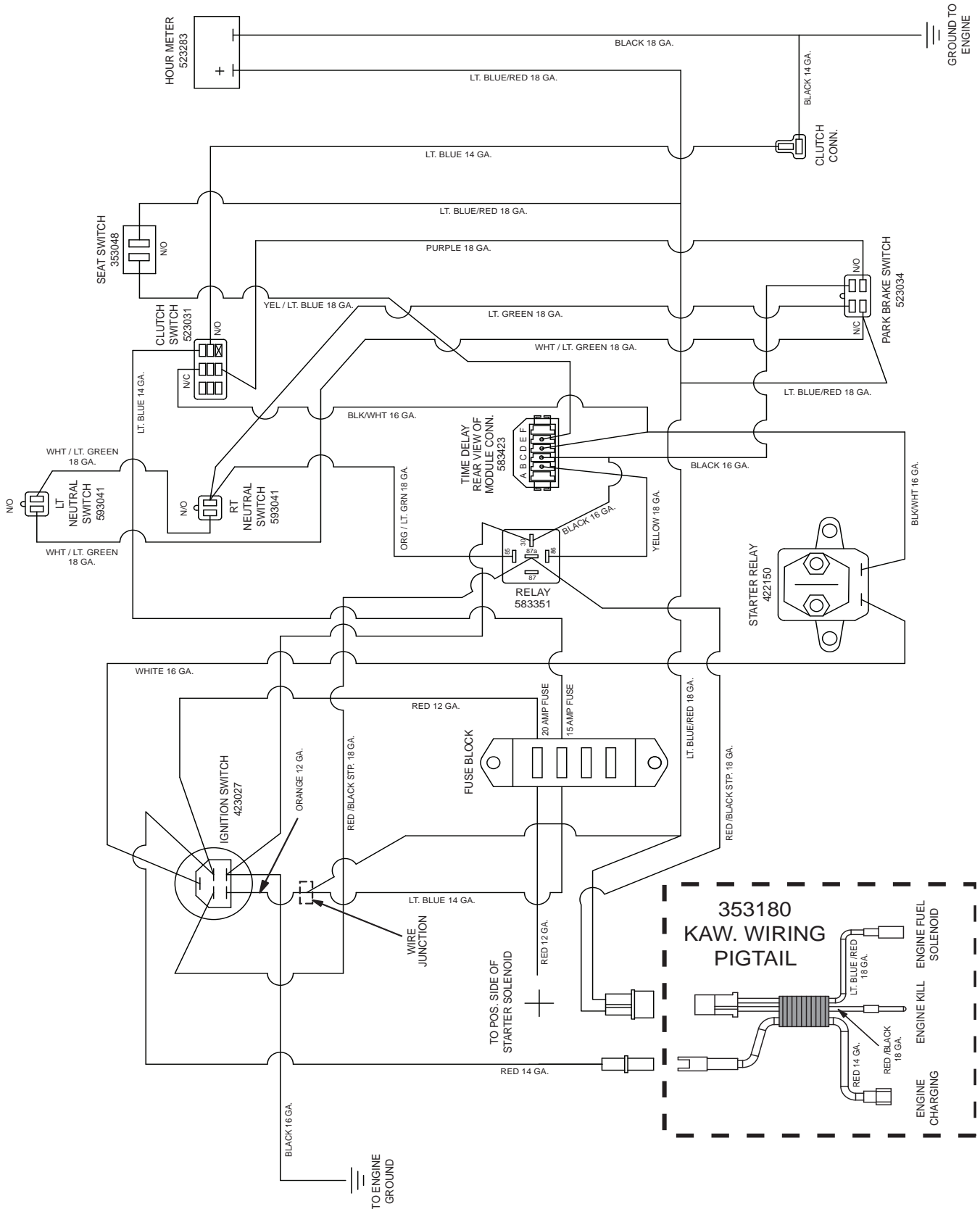



1



2



3



4



5

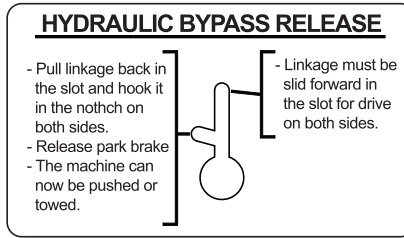

6

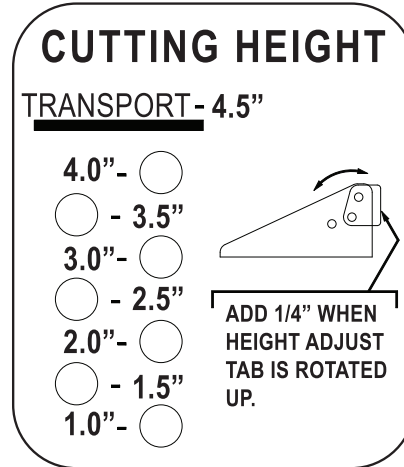

7

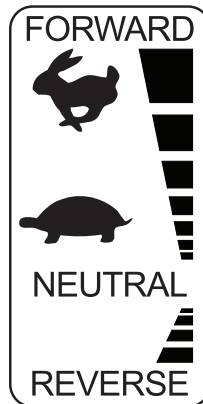

8



9



10



11



12



13

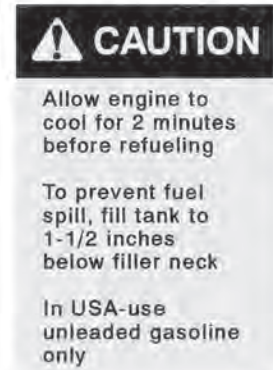

14



Decals

#	PART NO.	DESCRIPTION	QTY.
1	363026	SERIAL PLATE	1
2	423155	DECAL, RIDER CAUTION	1
3	423156	DECAL, PARK LEVER	1
4	823320	DECAL, BATTERY WARNING	1
5	823323	DECAL, ROTATING PARTS	1
6	353125	DECAL, BYPASS	1
7	353129	DECAL, HEIGHT ADJUST	1
8	353130	DECAL, MOTION CONTROL	2
9	353131	DECAL, TRANSPORT	1
10	353174	DECAL, FUZION	1
11	353185	DECAL, 42" DECK	1
12	363001	DECAL, CAUTION	1
13	363023	DECAL, DANGER	2
14	363290	DECAL, CAUTION FUEL	1

NOTE:

- A:** THERE ARE NO REPLACEMENT DECALS FOR TANKS, BECAUSE THEY ARE MOLDED INTO THE TANK.

Notes

Notes

Notes

