

# **X-TREME™**

## **60B25X**

### **PARTS MANUAL**



# Table of Contents

■ QUICK REFERENCE GUIDE FOR 60B25X.....	A - 1
■ DECK COMPONENTS .....	B - 1
■ DECK LIFT COMPONENTS .....	C - 1
■ FRAME COMPONENTS.....	D - 1
■ DRIVE COMPONENTS .....	E - 1
■ CONTROL COMPONENTS	
LINKAGE PARTS.....	F - 1
RIGHT HAND CONTROL BOX PARTS .....	F - 3
LEFT HAND CONTROL BOX PARTS .....	F - 5
■ BRAKE COMPONENTS	
RIGHT HAND SIDE .....	G - 1
LEFT HAND SIDE.....	G - 3
■ HYDRO COMPONENTS .....	H - 1
■ FUEL COMPONENTS .....	I - 1
■ ELECTRICAL SCHEMATICS.....	J - 1
■ DECAL LIST.....	K - 1
■ BLANK NOTE PAGES .....	L - 1

## 60B25X

### Engine

25hp Briggs & Stratton 44N777-0114

### Blades

603035 20"blade  
603055 20" mulch blade  
603056 20" super hi-lift blade

### Belts

603068 blade drive belt  
423272 pump drive belt

### Tires

533024 wheel/tire assy  
533069 drive tire (23x9.5X12)  
583058 rim w/ valvestem  
523280 front caster complete  
123049 tire (13x5x6 front caster)

### Spindles

583106 spindle assy comp.  
583111 housing  
363350 bearing  
583112 shaft  
583113 brg. Spacer tube

### Transmission

583325 wheel motor TJ0230US080AAAJ **Seal Kit # 583520**  
533079 hydro pump BDP-10A w/ RTN **Seal Kit # 533107**  
423361 hydro filter

\*\*\*synthetic hydro oil capacity approx. 2.7 qts.

**Throttle** 363352

**Choke** 423153

**Wire Harness** 423387

**Safety Module** 423030

### Electrical Components

423027 Ignition Switch  
422150 Starter Relay  
523034 Park Brake Switch  
593041 Neutral Switch  
523031 PTO Switch  
523030 Seat Switch  
523283 Hour Meter

**Clutch** 603078

### Torque Specs

65 ft-lbs blade bolt  
90 ft-lbs nut on top of spindle  
50 ft-lbs clutch bolt  
175-200 ft-lbs wheel motor axle nut

### Pulleys

423231 pump drive pulley  
523328 tensioner pulley-pump belt  
533052 pump pulley  
533114 tensioner pulley-blade drive belt  
583162 stationary idler pulley-deck  
603070 pulley-blade spindle

### Front Caster Bearings

533086 bearing

### Brakes

592094 wheel hub-shoe brake  
533032 drum brake link  
423310 brake drum  
423276 brake shoe  
423281 brake spring

### Seat

583077 seat complete w/ tracks  
583089 seat cushion  
583090 back cushion  
593097 molded arm rest

**Muffler** 533115

# X-TREME60 Deck Components

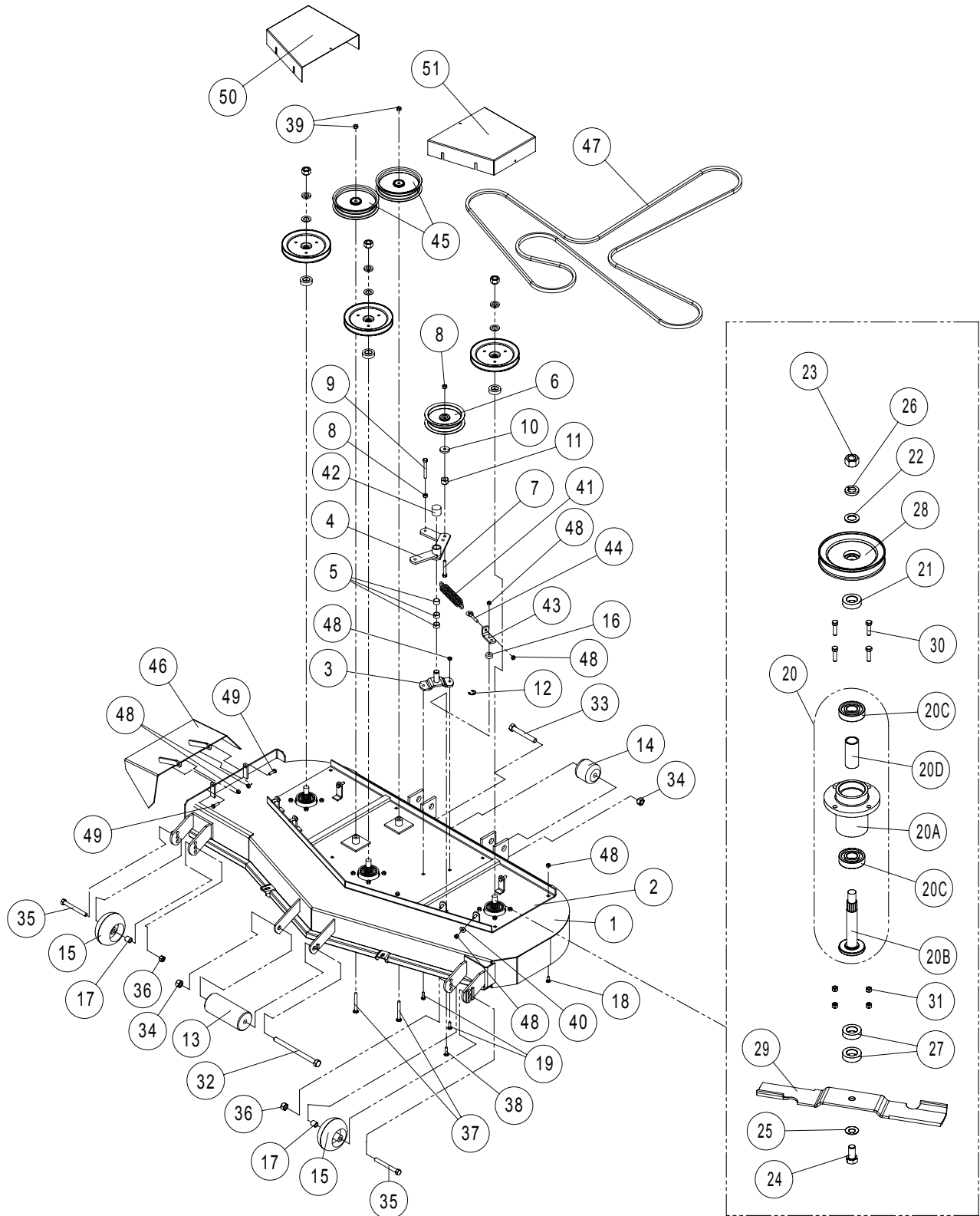



# Deck Components

#	PART NO.	QTY.	DESCRIPTION
1	532038	1	X60 MOWER DECK
2	532040	1	X60 DECK SUB PLATE
3	522104	1	OFFSET PIVOT
4	522164	1	Z-DECK TENSIONER W/ BSHNGS
5	363089	3	BRONZE BUSHINGS
6	533114	1	ENGAGEMENT IDLER
7	100298	1	3/8-16 X 2-1/2 HHCS
8	109007	2	3/8-16 WHIZ LOCK NUT
9	100300	1	3/8-16 X 3 HHCS
10	373089	1	RETAINING WASHER
11	823309	1	FRAME SPACER
12	108509	1	3/4 E-RING
13	603023	1	FRONT ANT-SCALP ROLLER
14	523084	1	REAR DECK ROLLER
15	423023	2	DECK ROLLER
16	483017	1	RH IDLER SPACER
17	453132	2	MOTOR MT. SPACER
18	107503	2	5/16-18 X 3/4 CARR. HEAD
19	107509	2	5/16-18 x 1 CARRIAGE BOLT
20	583106	3	BLADE SPINDLE ASSY
20A	583111	3	SPINDLE HOUSING
20B	583112	3	SPINDLE SHAFT
20C	363350	6	BEARING - BLADE SPINDLE
20D	583113	3	BEARING SPACER TUBE
21	583110	3	PULLEY SPACER
22	105269	3	3/4 SAE FLAT WASHER
23	104511	3	3/4-16 HEX NUT
24	100347	3	5/8-11 X 2 HHCS
25	583108	3	5/8 DISC SPRING WASHER
26	105010	3	3/4 LOCK WASHER
27	363382	6	BLADE SPACER
28	603070	3	7" HEX PULLEY
29	603035	3	20" BLADE
30	100274	12	5/16-18 X 1-1/4 HHCS
31	104256	12	5/16-18 NYLOC NUT
32	100351	1	5/8-11 X 8-1/2 HHCS
33	100346	1	5/8-11 X 4-1/2 HHCS
34	104261	2	5/8-11 HEX NUT
35	100336	2	1/2-13 X 4-1/2 HHCS
36	104259	2	1/2-13 NYLOCK NUT
37	107506	2	3/8-16 X 3-1/4 CARRIAGE BOLT
38	107524	1	5/16-18 X 1-1/4 CARR. BOLT
39	109007	2	3/8-16 WHIZ LOCK NUT



# Deck Components

#	PART NO.	QTY.	DESCRIPTION
40	105258	1	5/16 STD FLAT WASHER
41	523327	1	FLOATING IDLER SPRING
42	103009	1	CAPLUG 1-1/4
43	523094	1	SPRING MOUNT
44	363080	1	RIGHT EYEBOLT
45	583162	2	6" FLAT IDLER - 72"
46	582025	1	GRASS DEFLECTOR WLDMNT
47	603068	1	DECK DRIVE BELT
48	104256	8	5/16-18 NYLOC NUT
49	100273	2	5/16-18 X 1 HHCS
50	532042	1	X60 RH BELT COVER
51	532044	1	X60 LH BELT COVER

# X-TREME<sup>60</sup> Deck Lift Components

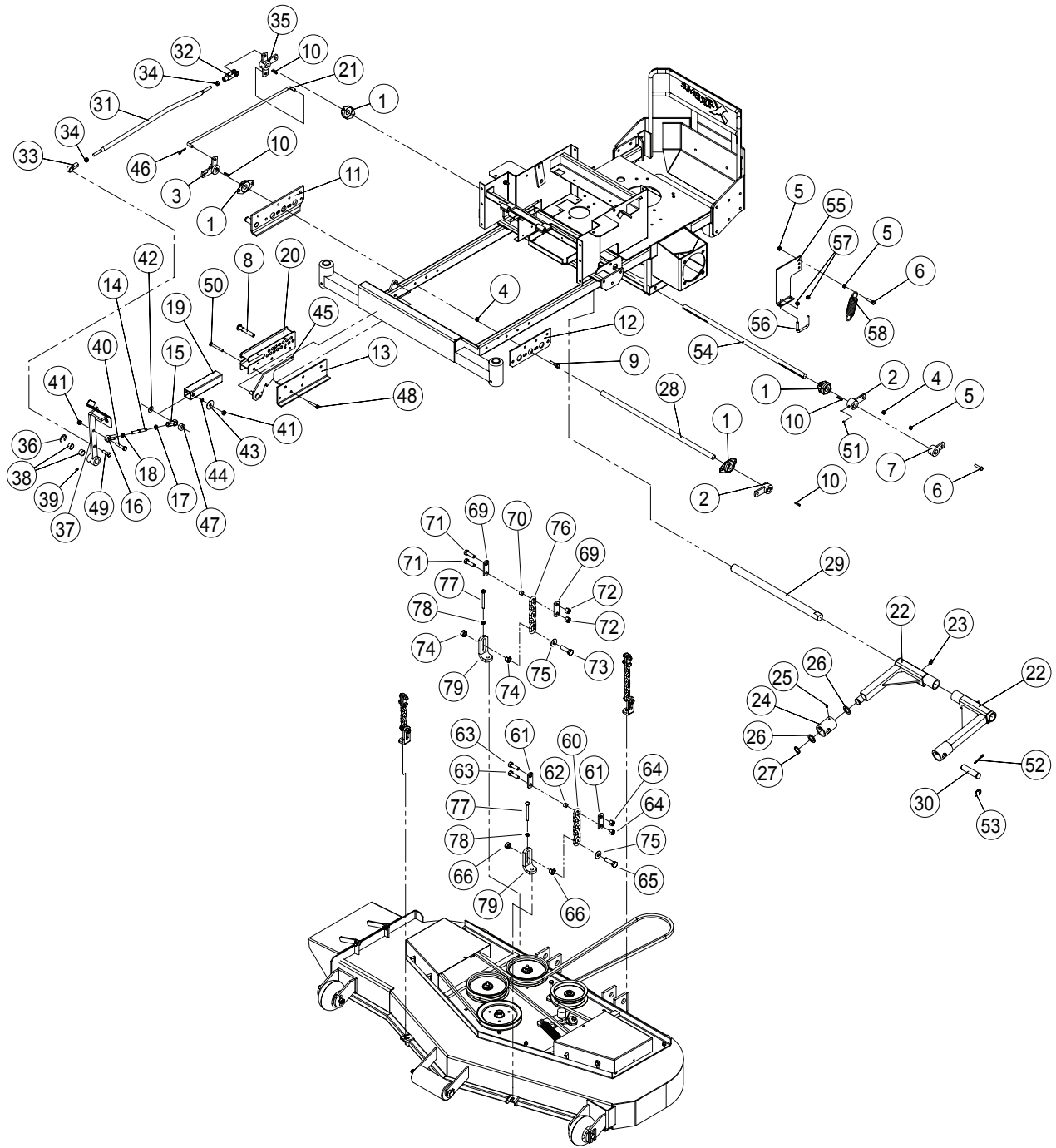



# Deck Lift Components

#	PART NO.	QTY.	DESCRIPTION
1	423140	4	3/4 2 BOLT BEARING
2	422041	2	DECK LIFT ARM
3	422043	1	DECK LIFT CRANK
4	104256	2	5/16 NYLOCK NUT
5	109001	3	5/16-18 WHIZLOCK NUT
6	100274	2	5/16-18 X 1-1/4 HHCS
7	422056	1	SPRING ASSIST ARM
8	109036	1	DECK HEIGHT PIN
9	100275	1	5/16-18 X 1 1/2 HHCS
10	107255	4	3/16 X 3/16 X 1 MACHINE KEY
11	422128	1	LIFT MOUNT
12	423344	1	LH LIFT MOUNT
13	423322	1	HEIGHT GAGE MOUNT
14	343158	1	FOOT PEDAL LINK
15	523104	1	ROD END RH 3/8
16	343160	1	ROD END LHF 3/8
17	104754	1	3/8-24 HEX JAM NUT
18	109037	1	3/8-24 LH HEX JAM NUT
19	343093	1	DECK HEIGHT TUBE
20	342016	1	HEIGHT CONTROL
21	523474	1	DECK LIFT ROD
22	532008	1	DECK ARM WELDMENT
23	111008	2	1/4-28 TAPER THREAD - 90 DEGREE ZERK
24	823074	1	DECK ARM SWIVEL
25	111004	1	1/4-28 ZERK
26	823015	2	DECK ARM WASHER RAW
27	108502	1	1.0 EXTERNAL SNAP RING
28	533010	1	LIFT SHAFT- FRONT
29	823050	1	DECK ARM SHAFT
30	823333	2	DECK ATTACH PIN
31	533060	1	DECK LIFT ROD
32	533083	1	CLEVIS END - 1/2"
33	533084	1	ROD END - 1/2"
34	104755	2	1/2-20 JAM NUT
35	532036	1	DECK LIFT HUB
36	108509	1	E-RING 3/4 DIA.
37	532034	1	DECK LIFT PEDAL
38	363089	2	BRONZE BUSHINGS
39	111004	1	1/4-28 ZERK
40	100295	1	3/8-16 X 1-3/4 HHCS
41	104257	2	3/8-16 NYLOCK NUT
42	105260	1	3/8 STANDARD FLAT WASHER
43	483019	1	RT. HAND IDLER WASHER





# Deck Lift Components

#	PART NO.	QTY.	DESCRIPTION
44	363174	1	EYE BOLT SPACER
45	532032	1	LIFT LOCK WELDMENT
46	363165	1	#3 HAIRPIN COTTOR
47	483017	1	RH IDLER SPACER
48	100276	1	5/16-18 X 1-3/4 HHCS
49	100293	1	3/8-16 x 1 1/4 HHCS
50	100279	1	5/16-18 X 2-1/2 HHCS
51	103292	1	1/4-28 SETSCREW
52	106778	2	3/16 X 1-1/2 COTTER PIN
53	108510	2	7/8 E-RING
54	423096	1	REAR DECK LIFT SHAFT
55	423382	1	SPRING MOUNT
56	523375	1	U-BOLT SQ. 2"
57	104256	2	5/16-18 NYLOCK
58	523327	1	FLOATING IDLER SPRING
59	423358	1	DECK LIFT ANGLE
60	423359	1	FRONT CHAIN
61	423356	2	LIFT CHAIN LINK
62	363174	1	EYE BOLT SPACER
63	100293	2	3/8-16 x 1 1/4 HHCS
64	104257	2	3/8-16 NYLOCK NUT
65	100311	1	7/16-14 X 1-1/2
66	109027	2	7/16-14 WHIZLOCK NUT
67	105260	1	3/8 STANDARD FLAT WASHER
68	423358	1	DECK LIFT ANGLE
69	423356	2	LIFT CHAIN LINK
70	363174	1	EYE BOLT SPACER
71	100293	2	3/8-16 x 1 1/4 HHCS
72	104257	2	3/8-16 NYLOCK NUT
73	100311	1	7/16-14 X 1-1/2
74	109027	2	7/16-14 WHIZLOCK NUT
75	105260	1	3/8 STANDARD FLAT WASHER
76	423360	1	REAR CHAIN
77	100008	4	1/4-20 X 2 HHCS
78	104758	4	1/4-20 HEX JAM NUT
79	533112	4	ADJUSTABLE CHAIN MOUNT

# X-TREME60

## Frame Components

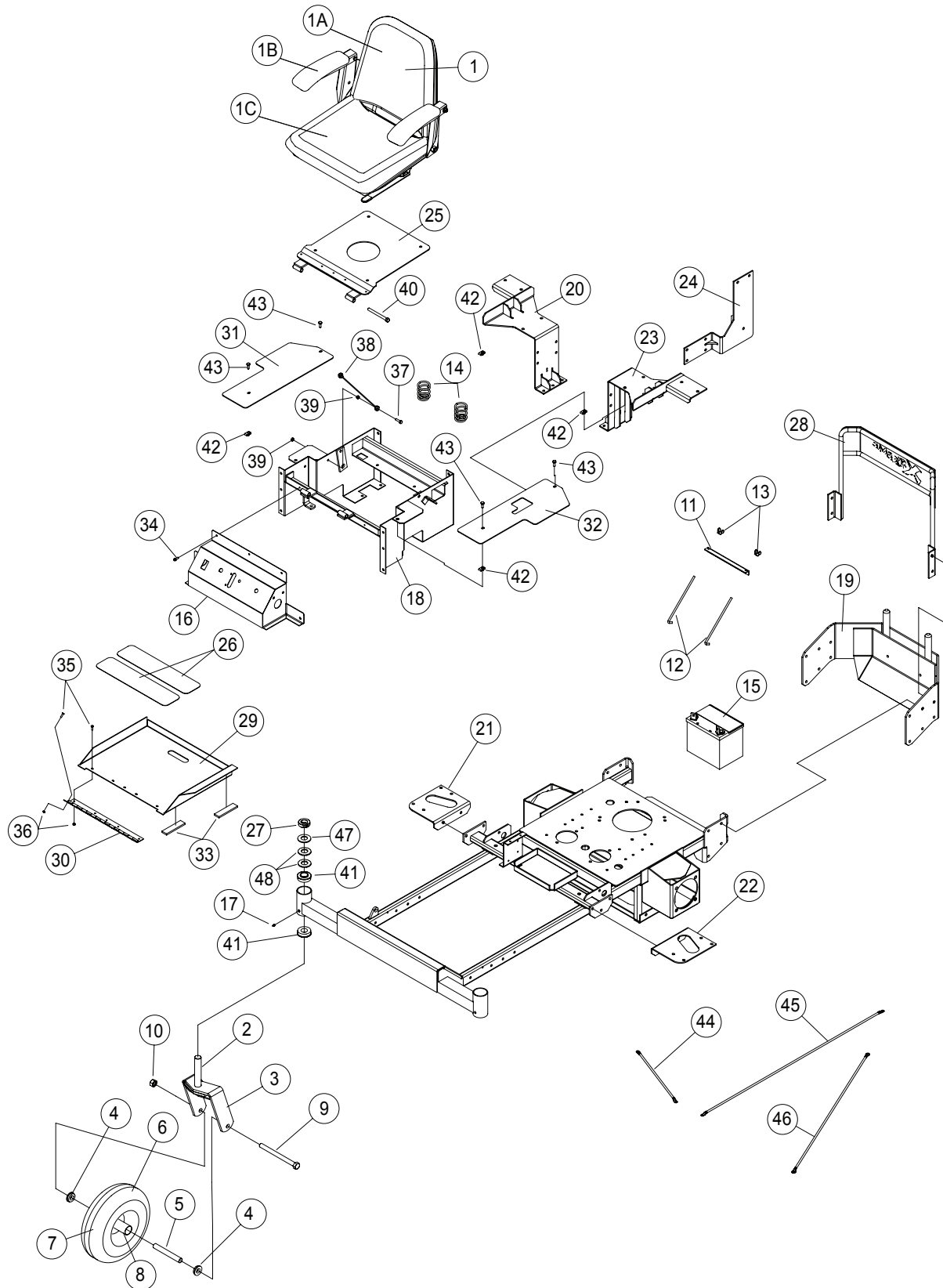



# Frame Components

#	PART NO.	QTY.	DESCRIPTION
1	583077	1	SEAT LT. GREY W/ TRACK
1A	583090	--	BACK SEAT CUSHION
1B	593097	--	MOLDED ARM REST
1C	583089	--	SEAT CUSHION
2	-----	--	N/A
3	522097	1	13" STRUT WELDMENT
4	533086	2	BEARING-FRONT WHEEL 3/4 BALL
5	523098	1	LARGE AXLE TUBE
6	523280	1	FRONT WHEEL COMPLETE
7	123049	1	TIRE (13 X 5 X 6)
8	533078	1	FRONT CASTER RIM
9	100349	1	5/8-11 X 7-1/2 HHCS
10	104261	1	5/8-11 HEX NUT
11	423011	1	HOLD DOWN ANGLE
12	423172	2	BATTERY HOLD DOWN RODS
13	109012	2	1/4 WING NUT
14	523278	2	SEAT SPRING
15	423142	1	BATTERY, U1-9
16	422148	1	CONTROL PANEL - Z
17	111001	1	1/8 NPT STRAIGHT ZERK
18	532012	1	SEAT FRAME WLDMNT - PNTD
19	532016	1	REAR GUARD
20	532022	1	RH REAR TANK MOUNT
21	533042	1	FRONT TANK PLATE RH
22	533044	1	FRONT TANK PLATE LH
23	532024	1	LH REAR TANK MOUNT
24	422136	1	OIL TANK MOUNT
25	422132	1	SEAT PLATE
26	343110	3	STEP TREAD - Z34
27	363145	2	1" CLAMP COLLAR
28	532010	1	AC GUARD WELDMENT
29	533026	1	FOOT PLATE
30	523105	1	HINGE
31	533046	1	RH SEAT PANEL
32	533048	1	LH SEAT PANEL
33	363201	2	GAS TANK PAD
34	102000	1	SELF TAPPING SCREW #12-24 X 5/8
35	101039	2	#10-24 X 5/8 PAN HD. SCREW
36	104252	2	#10 NYLOCK NUT
37	100004	1	1/4-20 x 1 HHCS
38	523044	1	SEAT CABLE
39	109000	2	1/4-20 WHIZ LOCK NUT
40	100303	1	3/8-16 X 4 HHCS



# Frame Components

#	PART NO.	QTY.	DESCRIPTION
41	363187	4	7/8 FLANGE BEARING
42	109015	4	1/4-20 NUT CLIP
43	100252	4	1/4-20 X 3/4 HHCS
44	423116	1	POSITIVE CABLE - SHORT
45	423117	1	POSITIVE CABLE - LONG
46	423118	1	NEGATIVE CABLE
47	583171	2	CASTER WASHER
48	105501	4	WAVY WASHER

# X-TREME60

## Drive Components

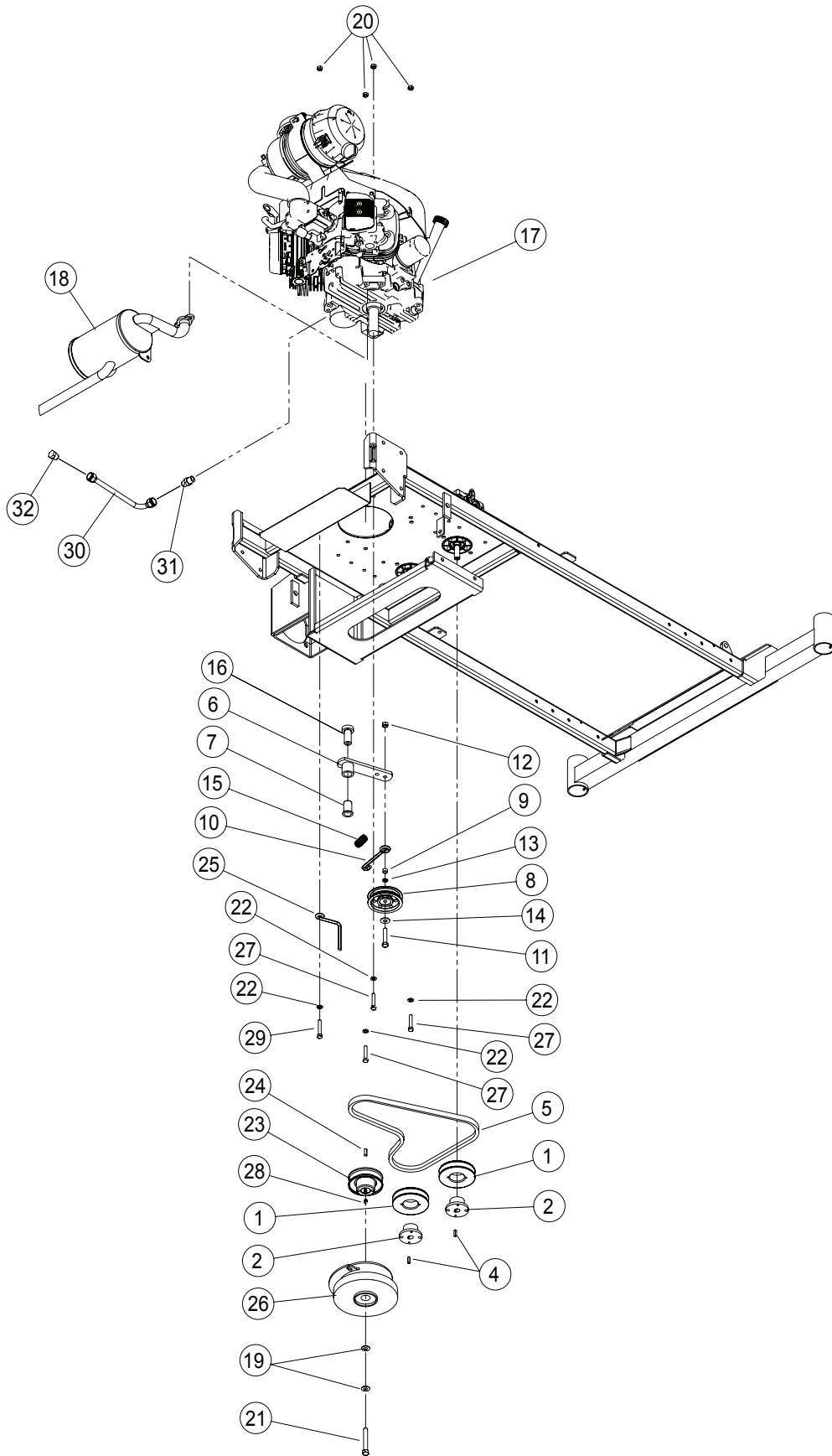



# Drive Components

#	PART NO.	QTY.	DESCRIPTION
1	533052	2	PUMP PULLEY
2	423178	2	15MM TAPER HUB
3	453074	4	90° ADAPTER
4	453102	2	PUMP KEY
5	423272	1	PUMP DRIVE BELT
6	422025	1	TENSIONER W/ BUSHING
7	523111	1	3/4 PLASTIC BUSHING
8	523328	1	FLAT IDLER
9	363174	1	EYE BOLT SPACER
10	423122	1	PUMP TENSION ROD
11	100296	1	3/8-16 X 2 HHCS
12	109007	1	3/8-16 WHIZ LOCK NUT
13	105005	1	3/8 LOCK WASHER
14	105260	1	3/8 STANDARD FLAT WASHER
15	553007	1	IDLER SPRING
16	423175	1	IDLER PIVOT
17	N/A	1	ENGINE
18	533115	1	MUFFLER - BRIGGS
19	423069	2	7/16 DISC SPRING WASHER
20	104256	4	5/16-18 NYLOCK
21	100536	1	7/16-20 X 3 HHCS
22	363226	4	5/16 DISC SPRING WASHER
23	423231	1	DRIVE PULLEY – PUMP
24	107258	1	1/4 X 1/4 X 3/4 MACH. KEY
25	373070	1	BELT GUIDE - LONG
26	603078	1	ELECTRIC CLUTCH – 200 FT LBS
27	100276	3	5/16-18 X 1-3/4 HHCS
28	103293	1	5/16-18 SET SCREW
29	100277	1	5/16-18 X 2 HHCS
30	533126	1	ENGINE DRAIN ELS
31	423070	1	ENGINE DRAIN ADAPTER
32	523065	1	ENGINE DRAIN PLUG

## Control Components - Linkage

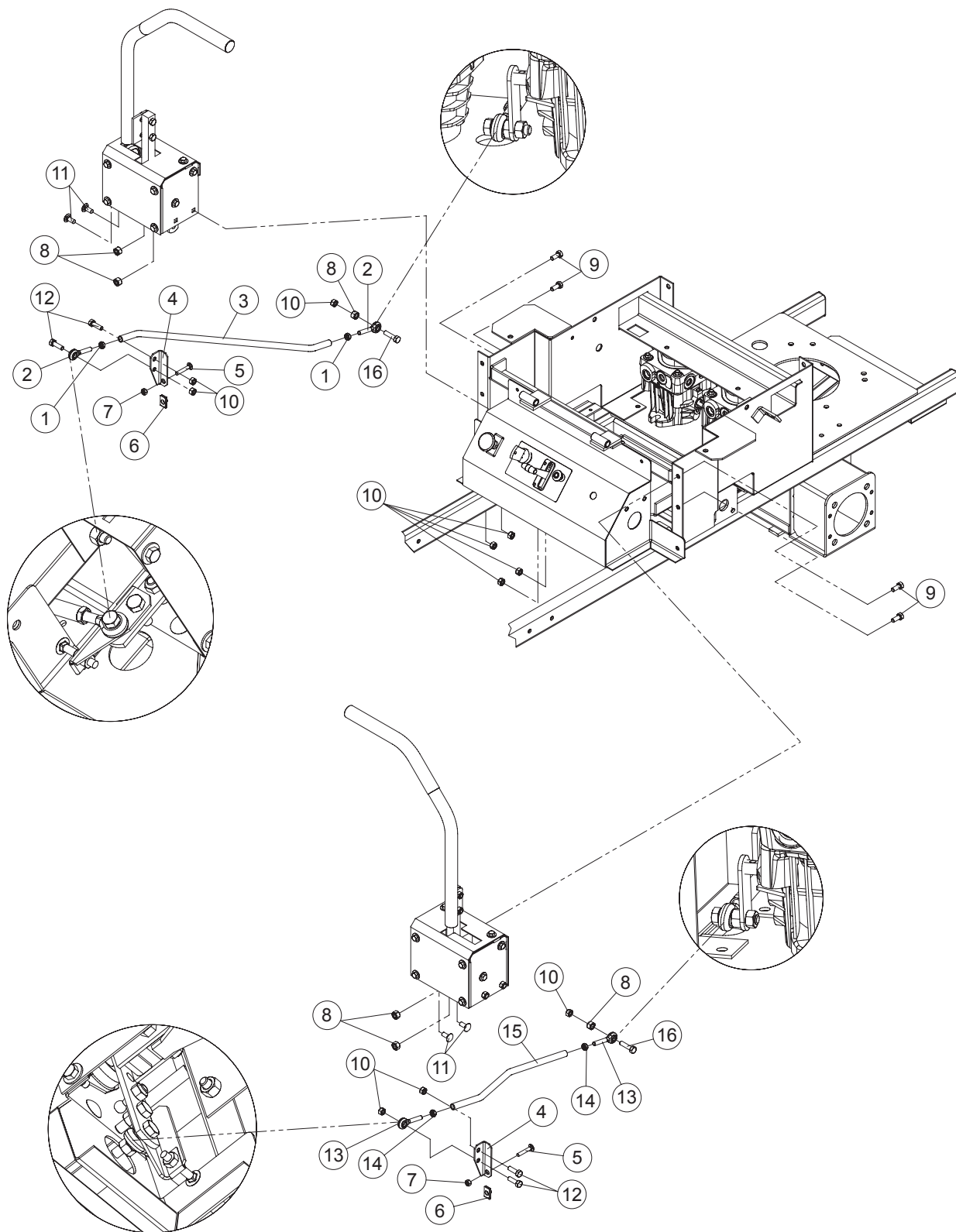



## Control Components - Linkage

#	PART NO.	QTY.	DESCRIPTION
1	104752	2	5/16-24 JAM NUT
2	453082	2	5/16 ROD END
3	423318	1	CONTROL LINK - RH
4	423376	2	LEVER STOP ANGLE
5	107523	2	1/4-20 X 1-1/2 CARR HD BOLT
6	109015	2	1/4-20 NUT CLIP
7	109000	2	1/4-20 WHIZ LOCK NUT
8	104256	7	5/16 NYLOCK NUT
9	100271	4	5/16-18 X 3/4 HHCS
10	104256	10	5/16-18 WHIZLOCK
11	107503	4	5/16-18 X 3/4 CARR BOLT
12	100273	4	5/16-18 X 1 HHCS
13	453082	2	5/16 ROD END
14	104752	2	5/16-24 JAM NUT
15	423317	1	CONTROL LINK - LH
16	100274	2	5/16-18 X 1-1/4 HHCS



## Control Components - RH Handles

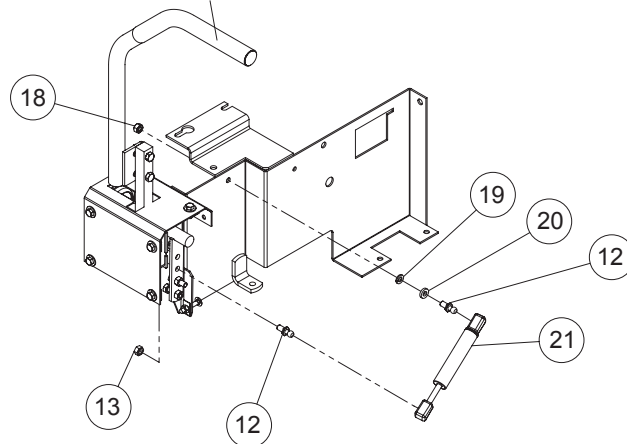
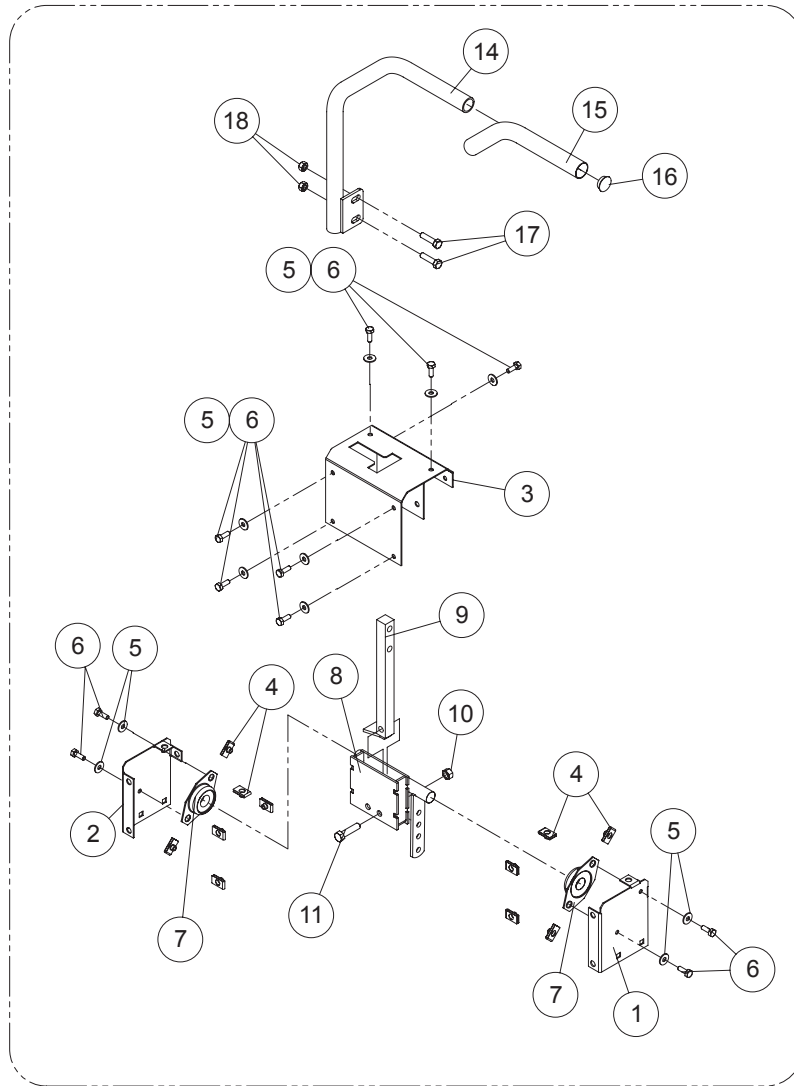



## Control Components - RH Handles

#	PART NO.	QTY.	DESCRIPTION
1	593028	1	LH CONTROL COVER
2	593026	1	RH CONTROL COVER
3	593022	1	RH CONTROL MOUNT
4	109015	11	1/4-20 NUT CLIP
5	105004	11	1/4 STD. LOCKWASHER
6	100252	11	1/4-20 X 3/4 HHCS
7	423140	2	3/4" 2 BOLT BEARING
8	592024	1	CONTROL PIVOT RIGHT
9	592060	1	HANDLE BAR W/ STOP WELDMENT
10	104257	1	3/8-16 NYLOCK
11	100294	1	3/8-16 - 1-1/2 HHCS
12	823221	2	10 MM BALL STUD
13	104256	2	5/16-18 NYLOC NUT
14	592041	1	HANDLE RH W/ GRIP
15	523032	1	HANDLE GRIP
16	523033	1	HANDLE PLUG
17	100274	2	5/16-18 X 1-1/4 HHCS
18	109001	2	5/16-18 WHIZLOCK NUT
19	105005	1	5/16 LOCKWASHER - HEAVY
20	253075	1	CABLE ANCHOR SPACER
21	823201	1	ANTI BUCK CYLINDER

## Control Components - LH Handles

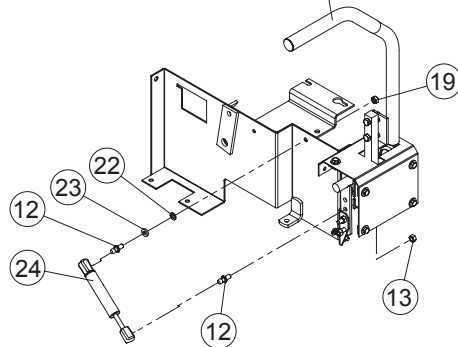
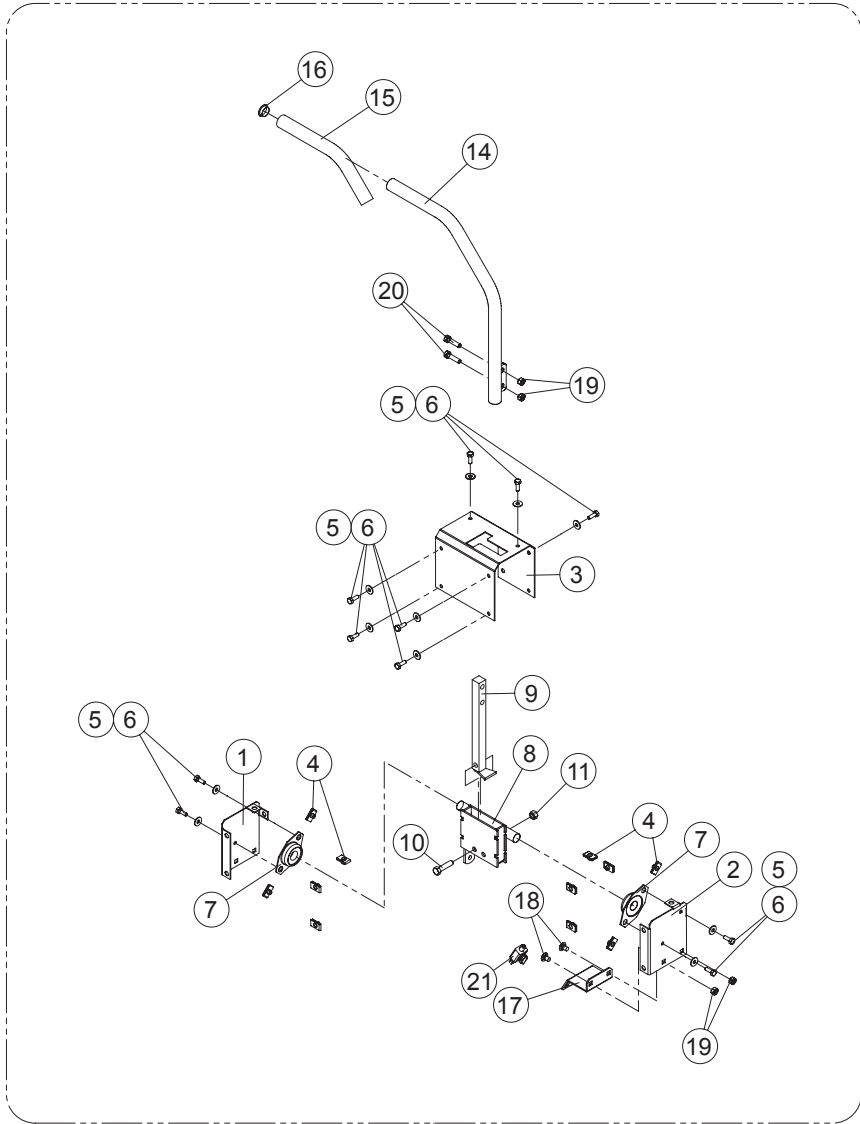



## Control Components - LH Handles

#	PART NO.	QTY.	DESCRIPTION
1	593026	1	RH CONTROL COVER
2	593028	1	LH CONTROL COVER
3	593024	1	LH CONTROL MOUNT
4	109015	11	1/4-20 NUT CLIP
5	105004	11	1/4 STD. LOCKWASHER
6	100252	11	1/4-20 X 3/4 HHCS
7	423140	2	3/4" 2 BOLT BEARING
8	592026	1	CONTROL PIVOT LEFT
9	592060	1	HANDLE BAR W/ STOP WELDMNT
10	100294	1	3/8-16 - 1-1/2 HHCS
11	104257	1	3/8-16 NYLOCK
12	823221	2	10 MM BALL STUD
13	104256	2	5/16-18 NYLOC NUT
14	592042	1	HANDLE LH W/ GRIP
15	523032	1	HANDLE GRIP
16	523033	1	HANDLE PLUG
17	593048	1	SWITCH MOUNT - NEUTRAL
18	107519	2	5/16-18 X 1/2 CARR BOLT
19	109001	4	5/16-18 WHIZLOCK NUT
20	100274	2	5/16-18 X 1-1/4 HHCS
21	593041	1	NEUTRAL SWITCH
22	105005	1	5/16 LOCKWASHER - HEAVY
23	253075	1	CABLE ANCHOR SPACER
24	823201	1	ANTI BUCK CYLINDER

## Brake Components - Right Hand

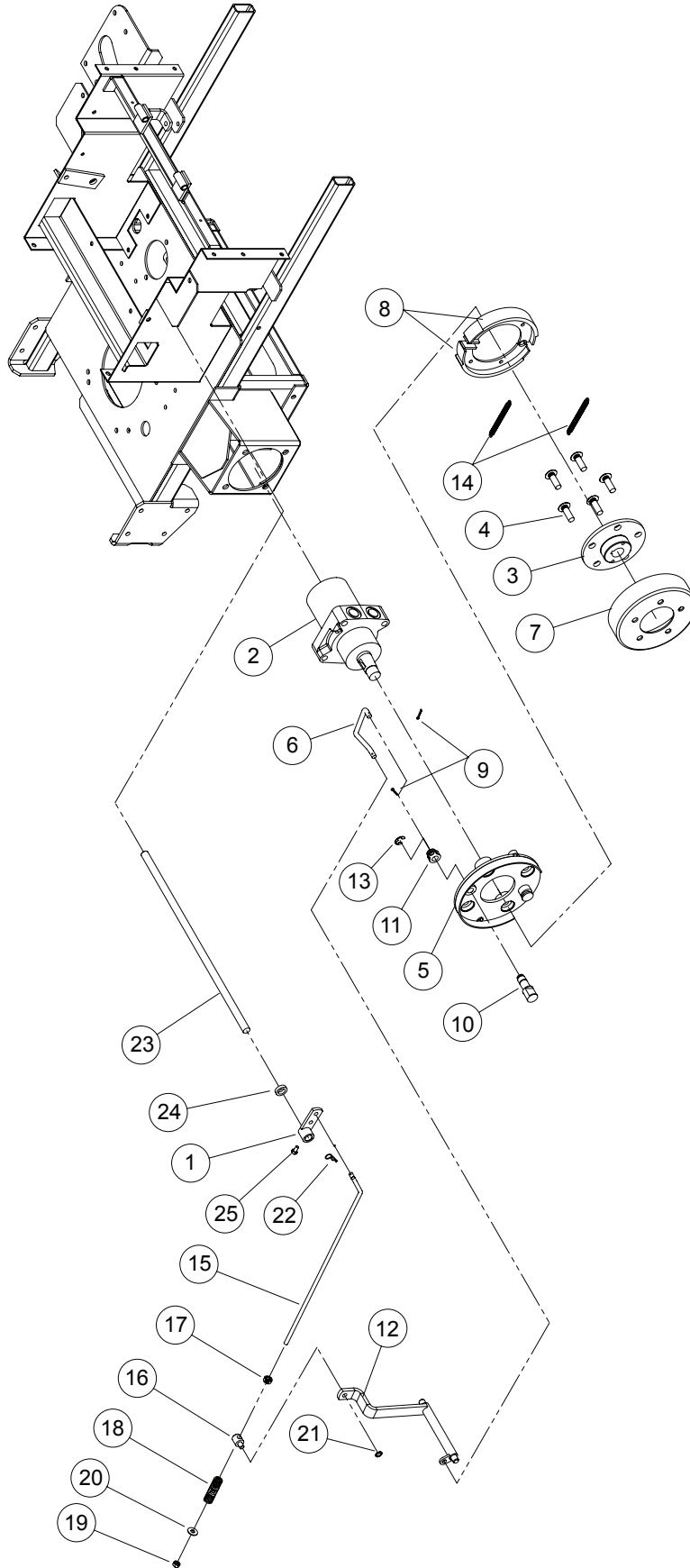



## Brake Components - Right Hand

#	PART NO.	QTY.	DESCRIPTION
1	422049	1	BRAKE CRANK WLDMNT - PLATED
2	583325	1	WHEEL MOTOR
3	592094	1	WHEEL HUB – SHOE BRAKE
4	103031	5	1/2-20 X 1 3/8 UNF PRESS IN STUD
5	592062	1	BACKPLATE - DRUM
6	533032	1	SHOE BRAKE LINK
7	423310	1	BRAKE DRUM – 180
8	423276	2	BRAKE SHOE
9	106753	2	3/32 X 3/4 COTTER PIN
10	423296	1	BRAKE CAM
11	423308	1	BRAKE CAM ARM
12	532026	1	BRAKE CONTROL - RH
13	108500	1	E-RING FOR 5/8 DIA.
14	423281	2	BRAKE SPRING
15	423128	1	PARK BRAKE LINK
16	423130	1	PARK BRAKE SWIVEL
17	523112	1	5/16 CLAMP COLLAR
18	523024	1	SPRING
19	104256	1	5/16 NYLOCK NUT
20	105258	1	5/16 FLAT WASHER
21	363177	1	3/8 PUSH NUT
22	363165	1	#3 HAIRPIN COTTOR
23	423368	1	BRAKE CROSS SHAFT
24	363170	1	BLADE SPACER
25	100501	1	1/4-28 X 1/2 HHCS

## Brake Components - Left Hand

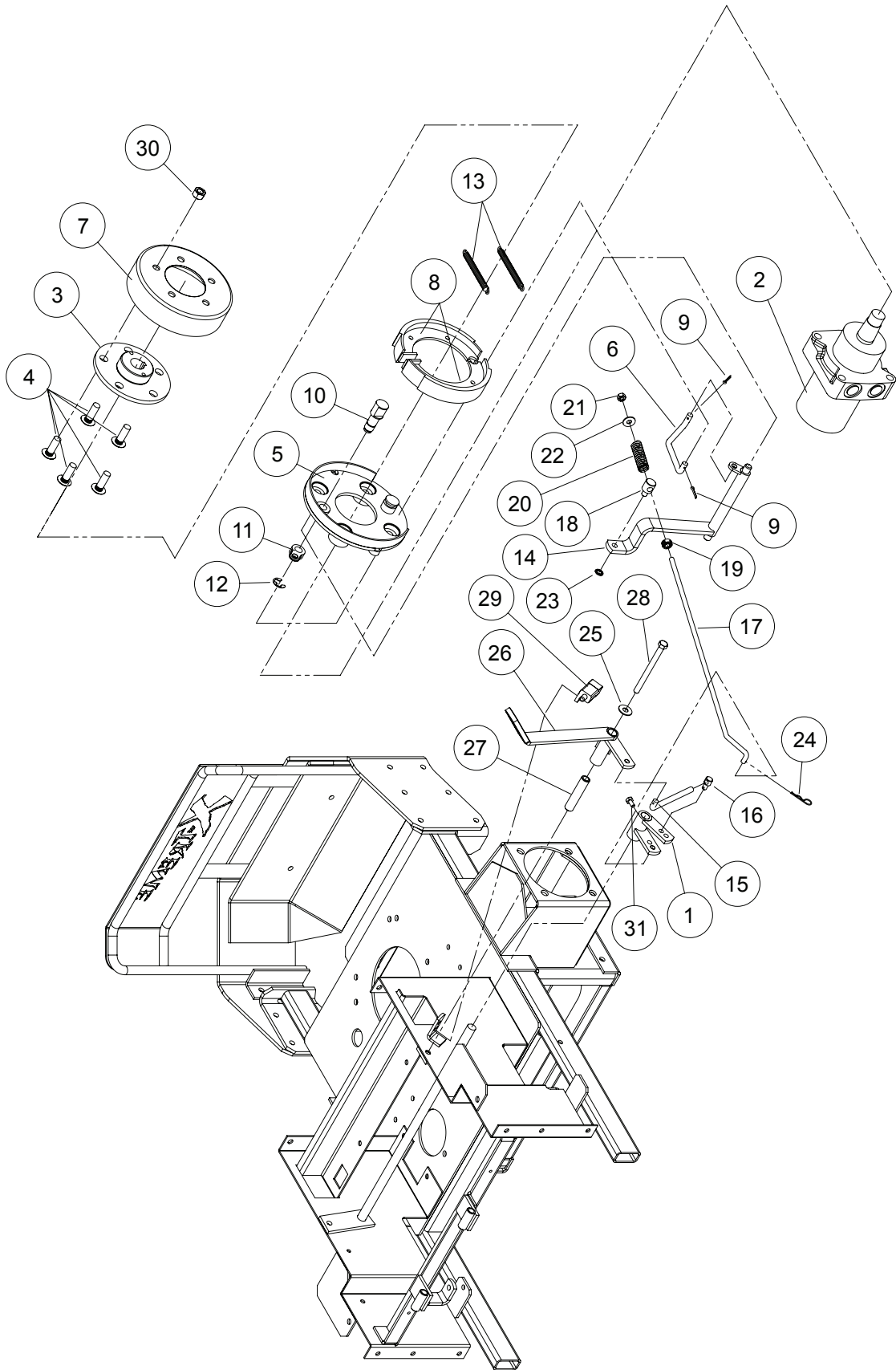



## Brake Components - Left Hand

#	PART NO.	QTY.	DESCRIPTION
1	422146	1	PARK BRAKE CRANK
2	583325	1	WHEEL MOTOR
3	592094	1	WHEEL HUB – SHOE BRAKE
4	103031	5	1/2-20 X 1 3/8 UNF PRESS IN STUD
5	592062	1	BACKPLATE - DRUM
6	533032	1	SHOE BRAKE LINK
7	423310	1	BRAKE DRUM – 180
8	423276	2	BRAKE SHOE
9	106753	2	3/32 X 3/4 COTTER PIN
10	423296	1	BRAKE CAM
11	423308	1	BRAKE CAM ARM
12	108500	1	E-RING FOR 5/8 DIA.
13	423281	2	BRAKE SPRING
14	532028	1	BRAKE CONTROL - LH
15	423350	1	BRAKE LINK
16	363029	1	.312 ROD SWIVEL
17	423128	1	PARK BRAKE LINK
18	423130	1	PARK BRAKE SWIVEL
19	523112	1	5/16 CLAMP COLLAR
20	523024	1	SPRING
21	104256	1	5/16 NYLOCK NUT
22	105258	1	5/16 FLAT WASHER
23	363177	1	3/8 PUSH NUT
24	363165	1	#3 HAIRPIN COTTOR
25	105260	1	3/8 STANDARD FLAT WASHER
26	422086	1	Z- PARK LEVER W/GRIP
27	363105	1	IDLER BUSHING
28	100305	1	3/8-16 X 4-1/2 HHCS
29	523034	1	PARK BRAKE SWITCH
30	103023	1	1/2-20 LUG NUT
31	100501	1	1/4-28 X 1/2 HHCS



## Hydro Components

#	PART NO.	QTY.	DESCRIPTION
1	533079	2	PUMP W/RTN - PARKER
2	453074	4	90° ADAPTER
3	583126	4	STRAIGHT ADAPTER
4	423307	1	OIL TANK
5	423361	1	OIL FILTER
6	583406	1	OIL TANK CAP
7	583325	2	WHEEL MOTOR
8	453127	2	PUMP TO PUMP FEED LINE
9	453106	2	SWIVEL TEE
10	593073	1	HOSE RETURN
11	423373	1	PUMP FEED LINE - Z
12	533113	1	RUBBER LINE L. OUTSIDE
13	523058	4	RETURN ADAPTER
14	533113	1	RUBBER LINE L. INSIDE
15	533113	1	RUBBER LINE R. INSIDE
16	533113	1	RUBBER LINE R. OUTSIDE

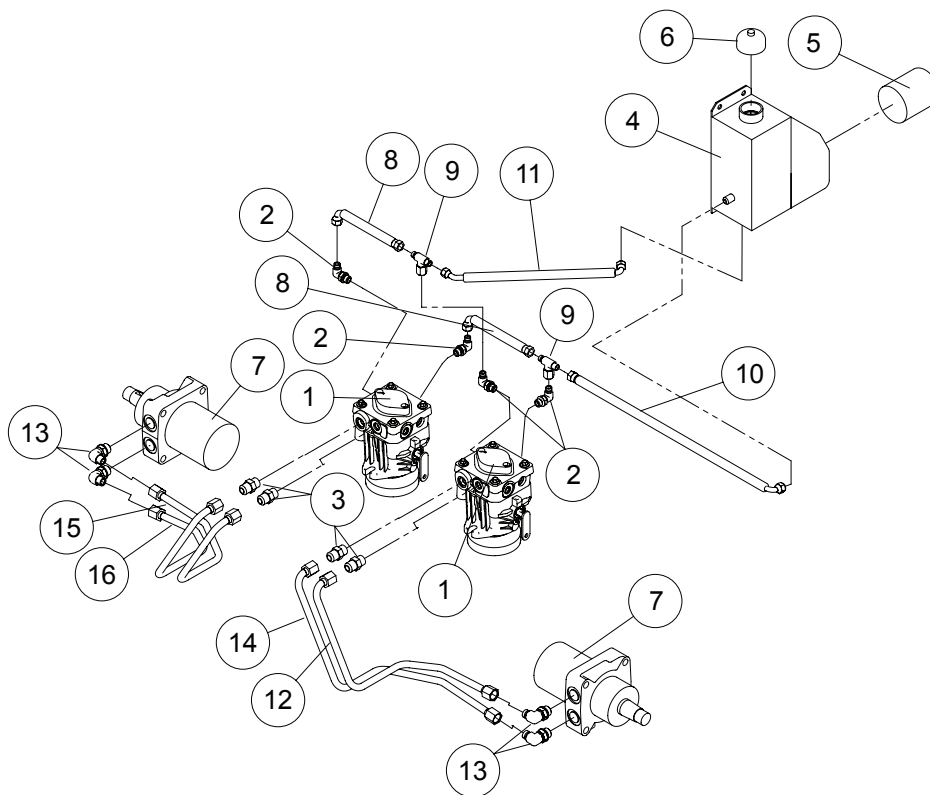

## Fuel Components

#	PART NO.	QTY.	DESCRIPTION
1	583050	1	FUEL VALVE
2	533085	1	FUEL LINE - 21 1/2"
3	583185	1	FUEL LINE - 39"
4	583186	1	FUEL LINE - 29"
5	363098	6	FUEL LINE CLAMP
6	105005	12	5/16 LOCK WASHER
7	100271	12	5/16-18 X 3/4 HHCS
8	823179	2	FUEL CAP - LARGE
9	583183	2	FUEL TANK ADAPTER
10	393042	2	VALVE GROMMET
11	533019	1	FUEL TANK / FENDER LH
12	533018	1	RH FUEL TANK

**NOTE:**

- A:** THERE ARE NO REPLACEMENT DECALS FOR TANKS. DUE TO THEIR MOLDED INTO THE TANK.

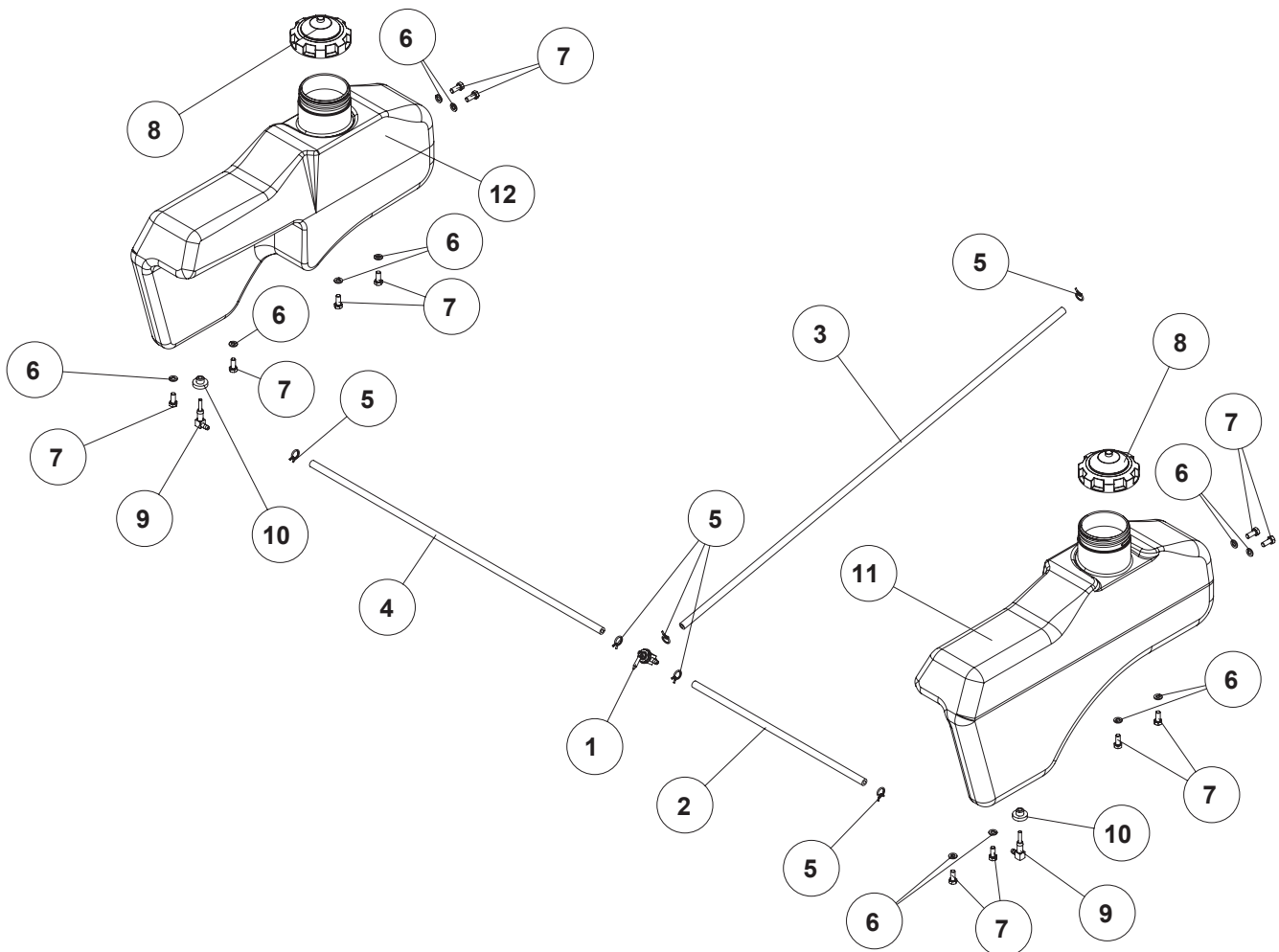

ENCORE PART # 423387  
 WIRE HARNESS FOR 48B20X, 20HP BRIGGS  
 WIRE HARNESS FOR 52B25X, 25HP BRIGGS  
 WIRE HARNESS FOR 60B25X, 25HP BRIGGS

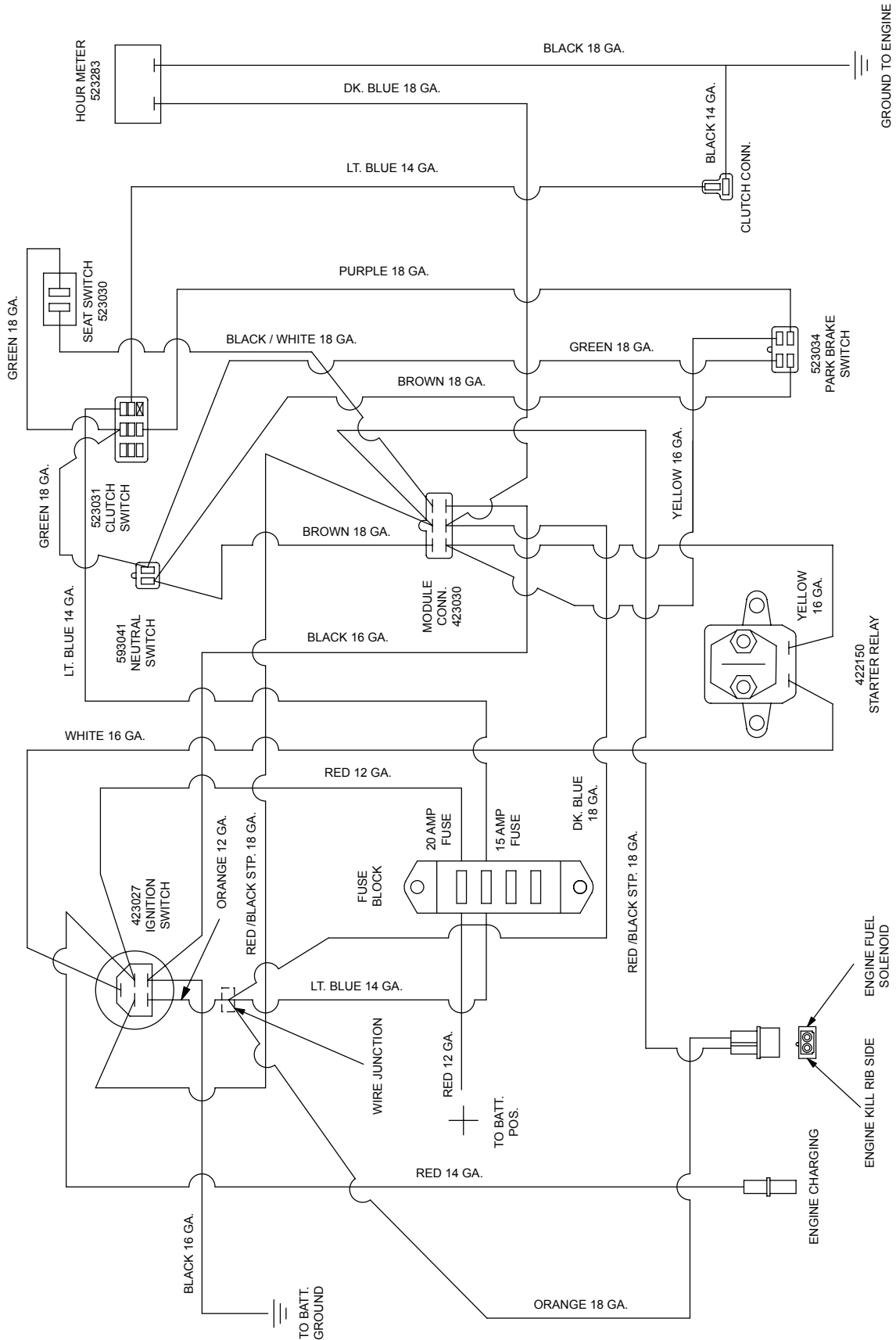

# X-TREME60

## Decal List



1



2

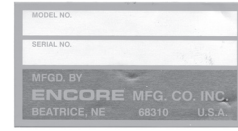

3

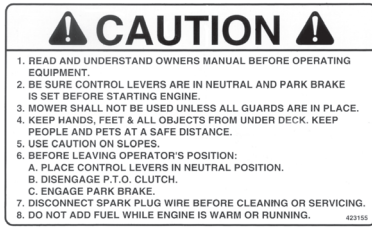

4

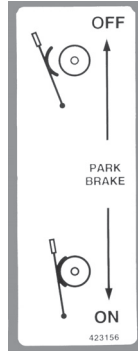

5

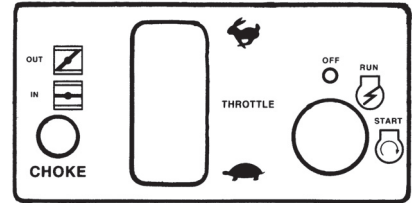

6



7



8

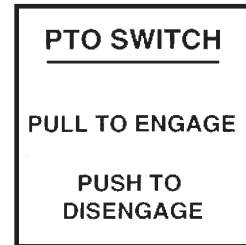

9

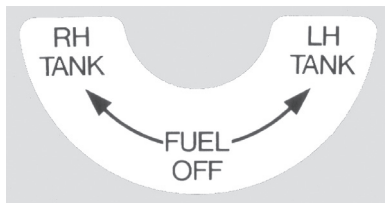

10

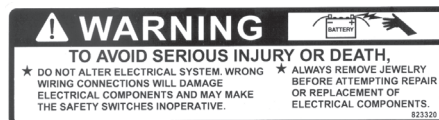

11



12

# X-TREME<sup>60</sup>

## Decal List

#	PART NO.	QTY.	DESCRIPTION
1	363001	1	CAUTION DECAL
2	363023	2	DANGER DECAL
3	363026	1	SERIAL NO. PLATE
4	423155	1	RIDER CAUTION DECAL
5	423156	1	PARK LEVER DECAL
6	423197	1	CONTROL DECAL
7	423354	1	OIL DECAL - SYN.
8	423379	1	CUT GAGE DECAL
9	523021	1	PTO DECAL
10	583023	1	LABEL - FUEL VALVE
11	823320	1	BATTERY WARNING DECAL
12	533067	1	FRONT X60 LABEL
13	423196	1	BELT ROUTING DECAL

# Notes

---

# Notes

---

