



EW32FS481V

EW36FS481V

EW48FS481V

EW32FS481VCA

EW36FS481VCA

EW48FS481VCA



PARTS MANUAL



ENCORE MANUFACTURING

A DIVISION OF WORL DLAWN POWER EQUIPMENT, INC.

ENCOREEQUIPMENT.COM

2415 ASHLAND AVE

BEATRICE, NE 68310

800-267-4255

FAX – 402-223-4103

CONTENT



Content

WHOLE MOWER.....	2
DECK ASM, 32" FIXED.....	3
DECK ASM, 36" FIXED.....	5
DECK ASM, 48" FIXED.....	7
REAR DECK ASM, 32" BELT.....	9
REAR DECK ASM, 36" /48" BELT DRIVE.....	11
HANDLE ASM, BELT LOWER.....	13
HANDLE ASM, UPPER B-D.....	14
YOKE CASTER COMPLETE.....	15
ASM, 36" RUBBER DEFLECTOR.....	16
ASM, 48" RUBBER DEFLECTOR.....	17
POWER ASM, FS481V BELT.....	18
FIVE GALLON EPA FUEL.....	19
WIRE.....	20
DECAL.....	21

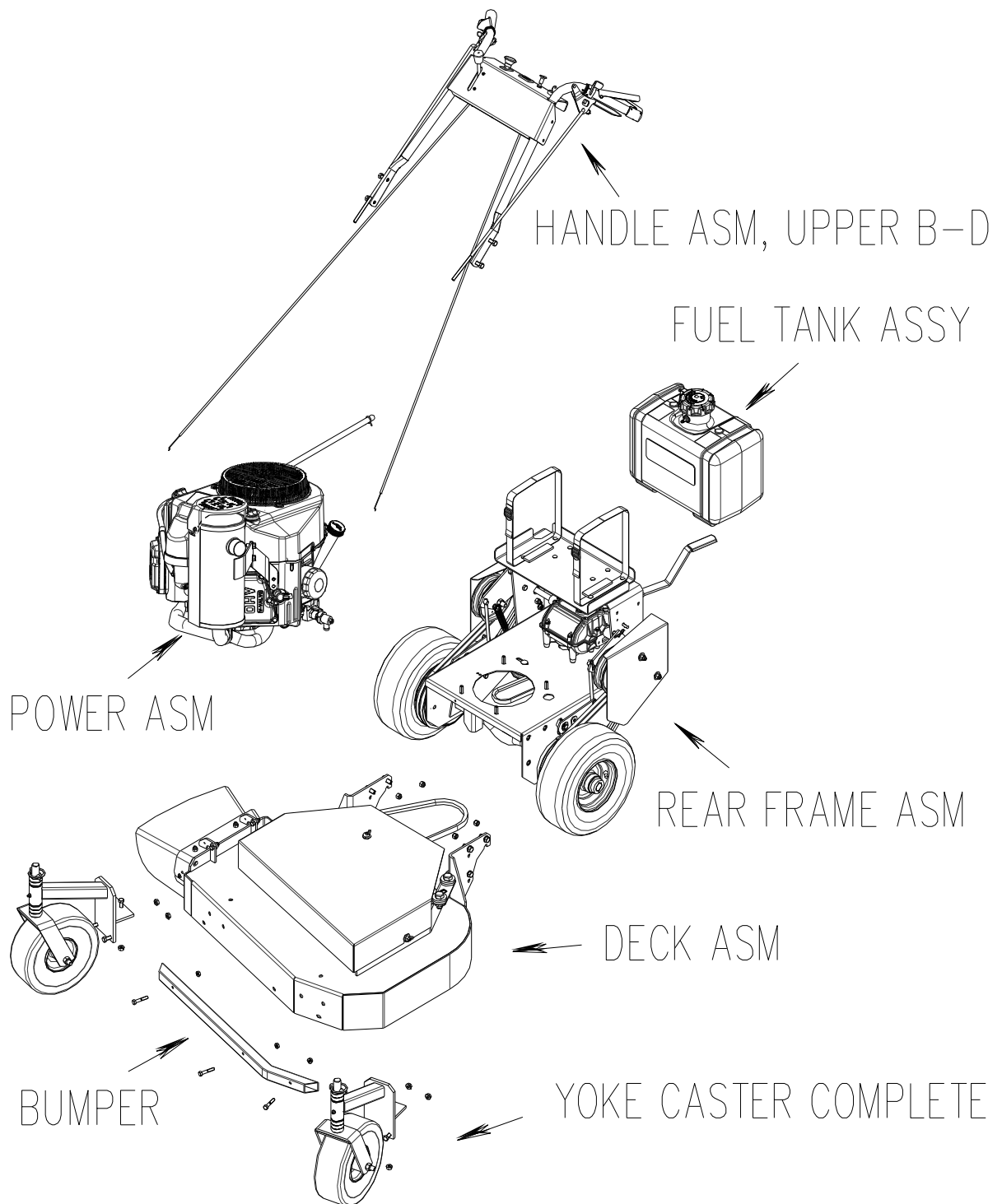

DECK ASM, 32" FIXED

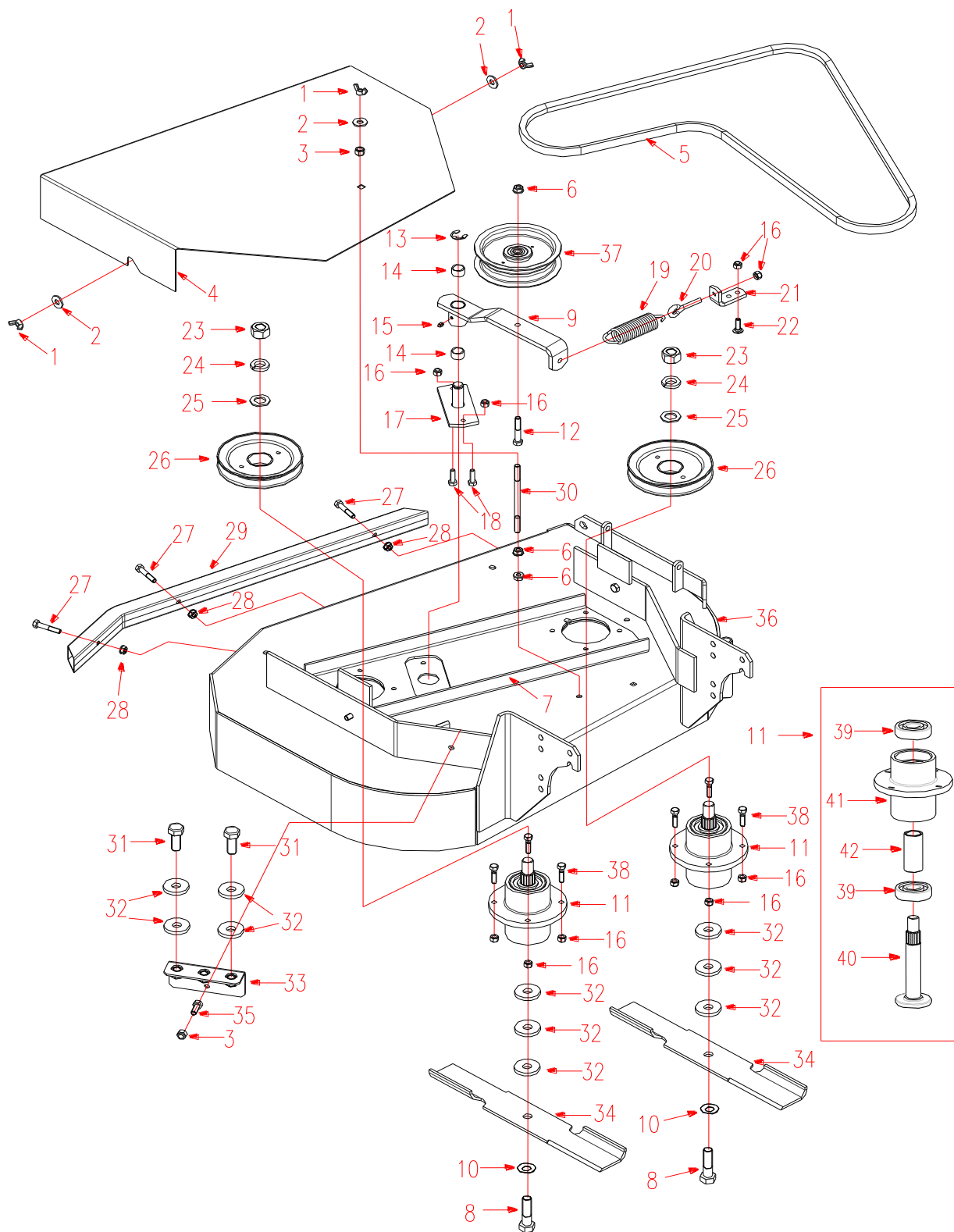



DECK ASM, 32" FIXED

ITEMS	PART NO.	DESCRIPTION	ITEMS	PART NO.	DESCRIPTION
1	103027	3/8-16 WINGNUT-PLTD	22	107509	5/16-18 X 1 CARR. BOLT
2	105260	3/8 STD FLAT WASHER	23	104511	3/4-16 UNF REG HEX NUT
3	104257	3/8-16 HEX NYLOC NUT	24	105010	3/4 LOCKWASHER
4	322002	32" BELT COVER WLDMT	25	105269	3/4 SAE FLAT WASHER
5	323003	BLADE DRIVE BELT	26	363378	RAISED PULLEY - 5 3/4
6	109007	3/8-16 WHIZLOCK NUT	27	100276	5/16-18 X 1-3/4 HHCS
7	323031	32" DECK CHANNEL	28	109001	5/16-18 WHIZLOCK NUT
8	100358	5/8-11 X 2-1/4 HHCS	29	323029	32" SQUARE BUMPER
9	482063	LEVER ASM, DECK IDLER	30	363090	BELT SHIELD SUPPORT
10	583108	5/8 SPRING DISC WASHER	31	100356	5/8-11 X 1-1/2 HHCS
11	363379	CUTTER HOUSING ASSY-W/B	32	363382	BLADE SPACER
12	100296	3/8-16 X 2 HHCS	33	323019	LH Z-BAR
13	108509	E-RING 3/4 DIA.	34	483035	16" BLADE
14	363089	ENGAGEMENT-BUSH	35	100292	3/8-16 X 1 HHCS
15	111004	1/4-28 ZERK	36	322004	32" FRONT DECK WLDMT
16	104256	5/16-18 HEX NYLOC NUT	37	363264	ENGAGEMENT IDLER
17	362024	IDLER PIVOT ASSY	38	100274	5/16-18 X 1-1/4 HHTB
18	100273	5/16-18 X 1 HHCS	39	363350	BEARING
19	523327	FLOATING IDLER SPRING	40	583112	SPINDLE SHALFT
20	363080	EYEBOLT-RIGHT	41	363380	BEARING BLOCK
21	523094	SPRING MOUNT-DECK	42	583113	SEPARATE SLEEVE

DECK ASM, 36" FIXED

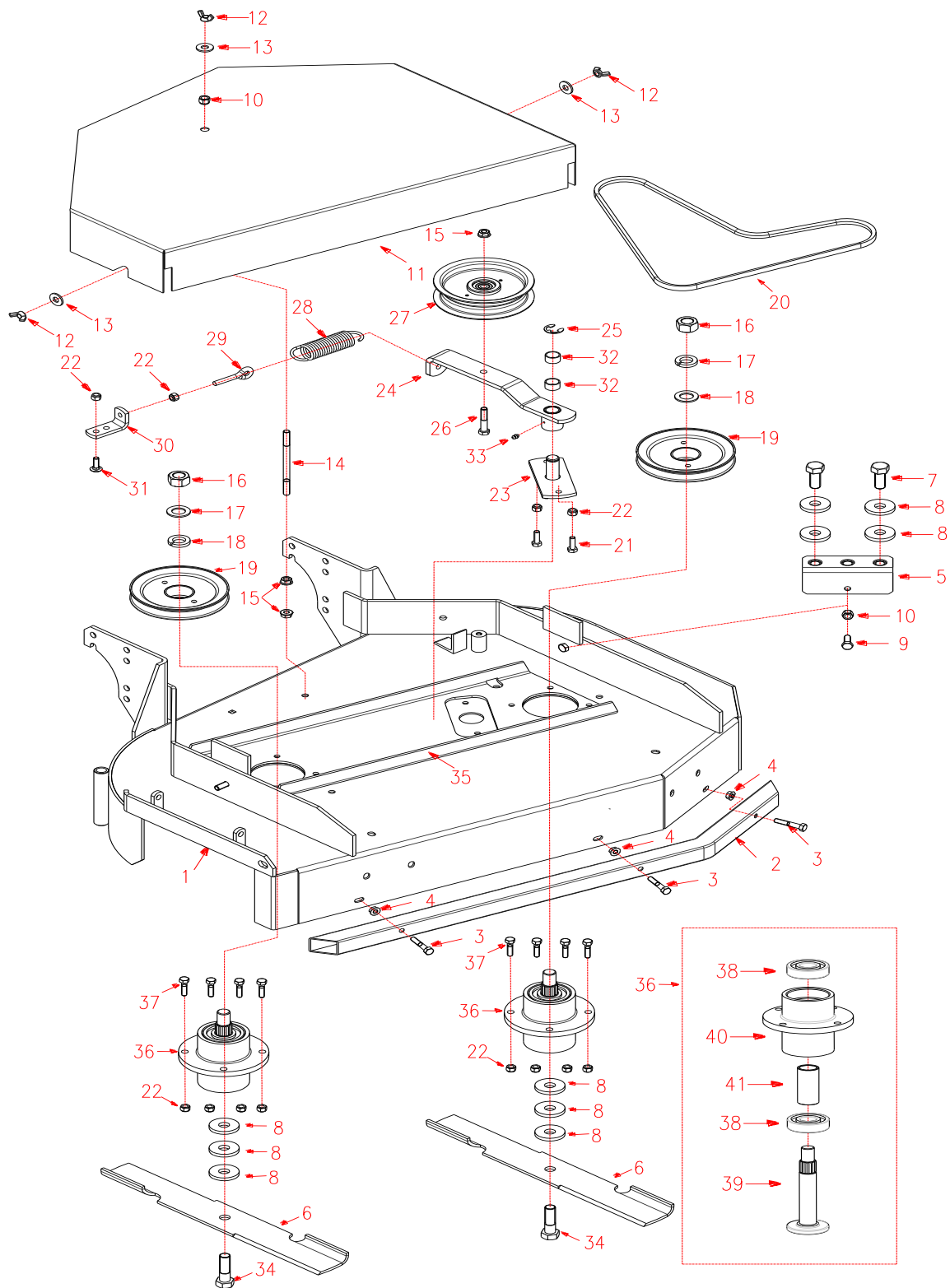



DECK ASM, 36" FIXED

ITEMS	PART NO.	DESCRIPTION	ITEMS	PART NO.	DESCRIPTION
1	362106	36" FRONT DECK WLDMT	22	104256	5/16-18 HEX NYLOC NUT
2	363304	36" SQ. BUMPER	23	362024	IDLER PIVOT ASSY
3	100276	5/16-18 X 1-3/4 HHCS	24	482063	LEVER ASM, DECK IDLER
4	109001	5/16-18 WHIZLOCK NUT	25	108509	E-RING 3/4 DIA.
5	323019	LH Z-BAR	26	100296	3/8-16 X 2 HHCS
6	363291	18" BLADE	27	363264	ENGAGEMENT IDLER
7	100356	5/8-11 X 1-1/2 HHCS	28	523327	FLOATING IDLER SPRING
8	363382	BLADE SPACER	29	363080	EYEBOLT-RIGHT
9	100292	3/8-16 X 1 HHCS	30	523094	SPRING MOUNT-DECK
10	104257	3/8-16 HEX NYLOC NUT	31	107509	5/16-18 X 1 CARR. BOLT
11	362105	BELT SHIELD ASSY	32	363089	ENGAGEMENT-BUSH
12	103027	3/8-16 WINGNUT-PLTD	33	111004	1/4-28 ZERK
13	105260	3/8 STD FLAT WASHER	34	100358	5/8-11 X 2-1/4 HHCS
14	363090	BELT SHIELD SUPPORT	35	362107	DECK CHANNEL - 36"
15	109007	3/8-16 WHIZLOCK NUT	36	363379	CUTTER HOUSING ASSY-W/B
16	104511	3/4-16 UNF REG HEX NUT	37	100274	5/16-18 X 1-1/4 HHTB
17	105010	3/4 LOCKWASHER	38	363350	BEARING
18	105269	3/4 SAE FLAT WASHER	39	583112	SPINDLE SHALFT
19	363378	RAISED PULLEY - 5 3/4	40	363380	BEARING BLOCK
20	363210	BLADE DRIVE BELT	41	583113	SEPARATE SLEEVE
21	100273	5/16-18 X 1 HHCS			

DECK ASM, 48" FIXED

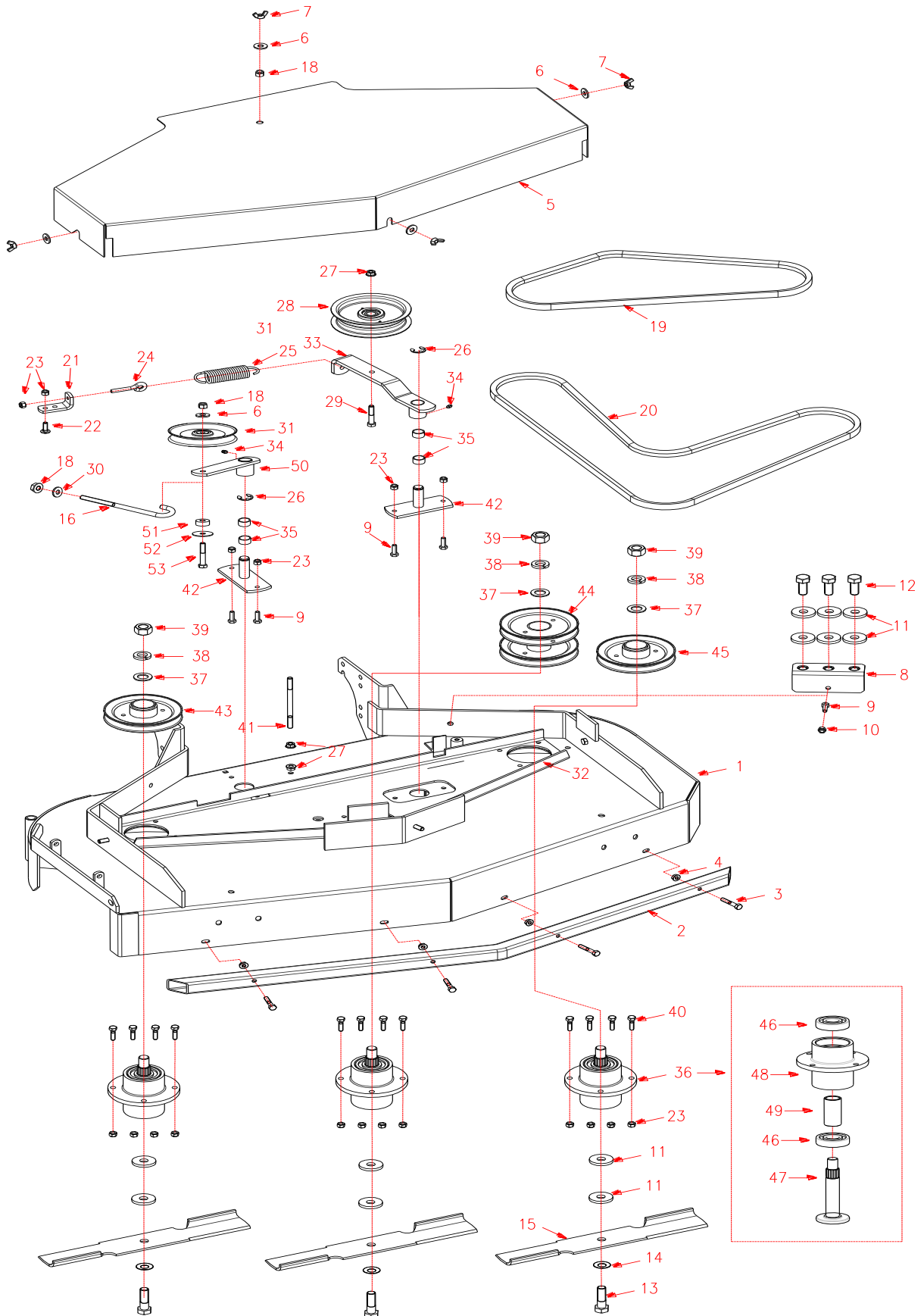



DECK ASM, 48" FIXED

ITEMS	PART NO.	DESCRIPTION	ITEMS	PART NO.	DESCRIPTION
1	482069	48" FRONT DECK	28	363264	ENGAGEMENT IDLER
2	483043	48" SQ. BUMPER	29	100296	3/8-16 X 2 HHCS
3	100276	5/16-18 X 1-3/4 HHCS	30	105260	3/8 STD FLAT WASHER
4	109001	5/16-18 WHIZLOCK NUT	31	483025	RH IDLER PULLEY
5	482068	48" BELT SHIELD	32	482070	48" DECK CHANNEL WLDMT
6	105260	3/8 STD FLAT WASHER	33	482063	LEVER ASM, DECK IDLER
7	103027	3/8-16 WINGNUT	34	111004	1/4-28 ZERK
8	322019	SPACER HOLDER	35	363089	ENGAGEMENT-BUSH
9	100273	5/16-18 X 1 HHCS	36	363379	CUTTER HOUSING ASM
10	104256	5/16-18 HEX NYLOC NUT	37	105269	3/4 SAE FLAT WASHER
11	363382	BLADE SPACER	38	105010	3/4 LOCKWASHER
12	100356	5/8-11 X 1-1/2 HHCS	39	104511	3/4-16 UNF REG HEX NUT
13	100358	5/8-11 X 2-1/4 HHCS	40	100274	5/16-18 X 1-1/4 HHTB
14	583108	5/8 SPRING DISC WASHER	41	363090	BELT SHIELD SUPPORT
15	483035	16" BLADE	42	362024	IDLER PIVOT ASSY
16	483003	BELT TENSION ROD	43	363431	LOWERED PULLEY
17	105260	3/8 STD FLAT WASHER	44	363377	DOUBLE PULLEY - 5 3/4
18	104257	3/8-16 HEX NYLOC NUT	45	363378	RAISED PULLEY - 5 3/4
19	483031	RH BLADE BELT	46	363350	BEARING
20	483030	BLADE DRIVE BELT	47	583112	SPINDLE SHALFT
21	523094	SPRING MOUNT-DECK	48	363380	BEARING BLOCK
22	107509	5/16-18 X 1 CARR. BOLT	49	583113	SEPARATE SLEEVE
23	104256	5/16-18 HEX NYLOC NUT	50	482001	RH IDLER ARM
24	363080	EYEBOLT-RIGHT	51	483017	RH IDLER SPACER
25	108509	E-RING 3/4 DIA.	52	483019	RH IDLER WASHER
26	523327	FLOATING IDLER SPRING	53	100297	3/8-16 X 2-1/4 HHCS
27	109007	3/8-16 WHIZLOCK NUT			

REAR DECK ASM, 32" BELT

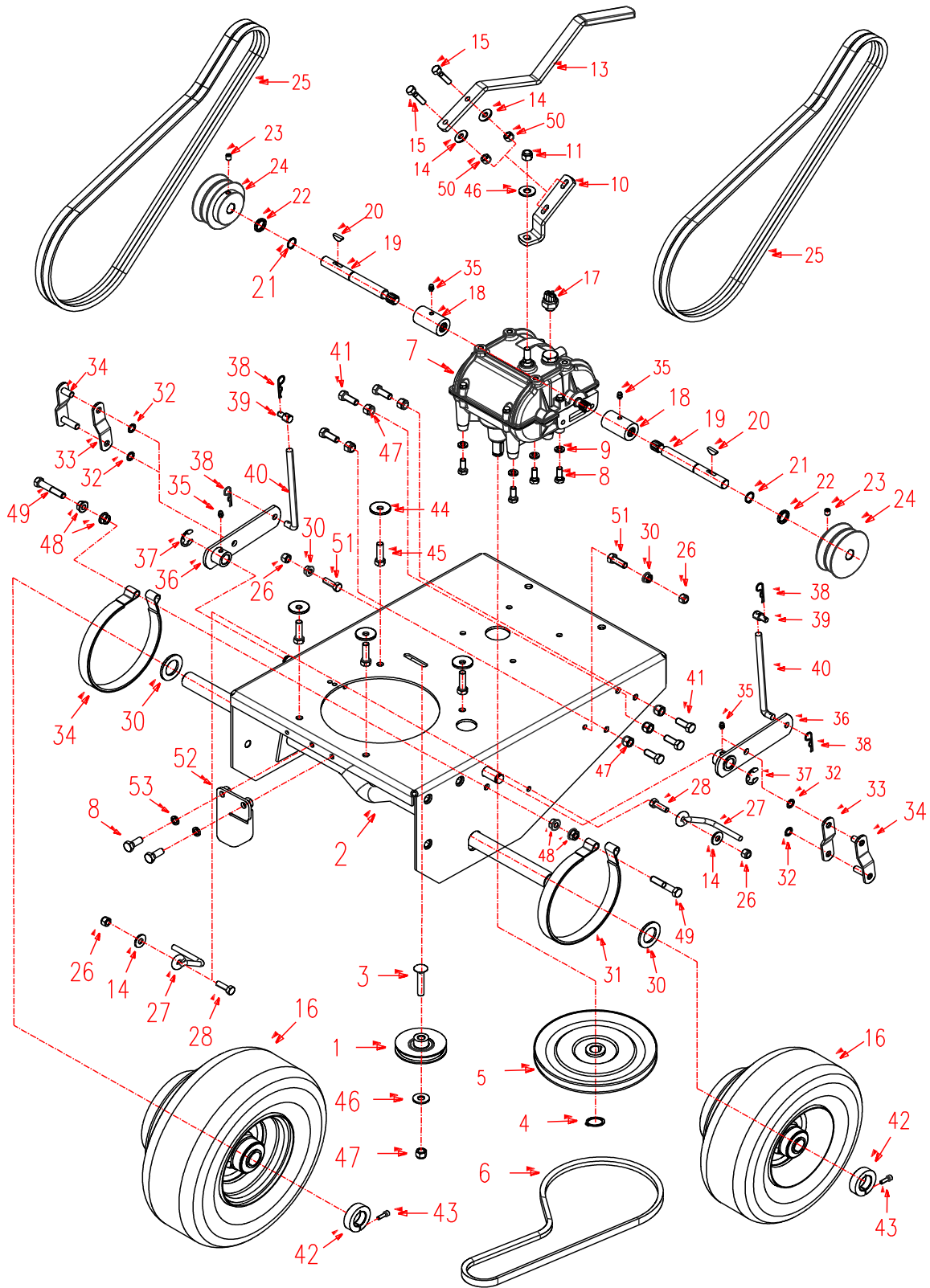



REAR DECK ASM, 32" BELT

ITEMS	PART NO.	DESCRIPTION	ITEMS	PART NO.	DESCRIPTION
1	363169	SMALL IDLER	28	100273	5/16-18 X 1 HHCS
2	322024	DECK WMT, 32 BELT REAR	29	109001	5/16-18 WHIZLOCK NUT
3	107501	3/8-16 X 2 CARR. BOLT	30	363121	WHEEL WASHER
4	108508	EXTERNAL SNAP RING 5/8	31	363176	6" BRAKE BAND
5	363220	TRANSMISSION SHEAVE	32	363177	3/8 PUSH NUT
6	363212	TRANSMISSION BELT	33	363135	BRAKE CONNECTOR
7	363430	TRANSMISSION, 5 SP WALK	34	362026	BRAKE CONNECTOR ASSY
8	B5783-820	SCREW, HH TAP M8x20	35	111004	1/4-28 ZERK
9	105005	5/16 LOCKWASHER-HEAVY	36	362042	LT BRAKE ARM ASSY
10	363128	SHIFTER BRKT	37	108500	E-RING 5/8 DIA.
11	104251	3/8-24 NYLOC NUT	38	363165	#3 ISSCO HAIRPIN COTTER (#2)
12	105260	3/8 STD FLAT WASHER	39	363029	.312 ROD SWIVEL
13	362060	SHIFTER LEVER	40	363142	BRAKE LINKAGE
14	105258	5/16 STD FLAT WASHER	41	100292	3/8-16 X 1 HHCS
15	100274	5/16-18 X 1-1/4 HHTB	42	363145	CLAMP COLLAR
16	323027	DRIVE WHEEL COMPLETE	43	B70. 1-510	CAP SCREW, 5 X 10 HEX
17	463128	TRANSMISSION SWITCH	44	753027	SPRING DISC WASHER
18	362086	9 SPL. COUPLER W/ZERK	45	100293	3/8-16 X 1-1/4 HHCS
19	363367	SHAFT EXTENSION - 9SPL.	46	105260	3/8 STD FLAT WASHER
20	107009	3/4 X 3/16 WOODRUFF KEY	47	104257	3/8-16 HEX NYLOC NUT
21	108508	EXTERNAL SNAP RING 5/8	48	109007	3/8-16 WHIZLOCK NUT
22	363087	TRANS SHAFT SPACER	49	100296	3/8-16 X 2 HHCS
23	103293	5/16-18 X 3/8 SETSCREW	50	104256	5/16-18 HEX NYLOC NUT
24	363137	2-GROOVE SHEAVE	51	100273	5/16-18 X 1 HHCS
25	363312	WHEEL DRIVE BELT, MATCHED SET OF 2	52	452186	WLD, CLUTCH TORSION
26	104256	5/16-18 HEX NYLOC NUT	53	B93-8	Washer 8 - LOCKWASHER
27	363075	ROUND BELT GUIDE	54	362041	RT BRAKE ARM ASSY

REAR DECK ASM, 36"/48" BELT

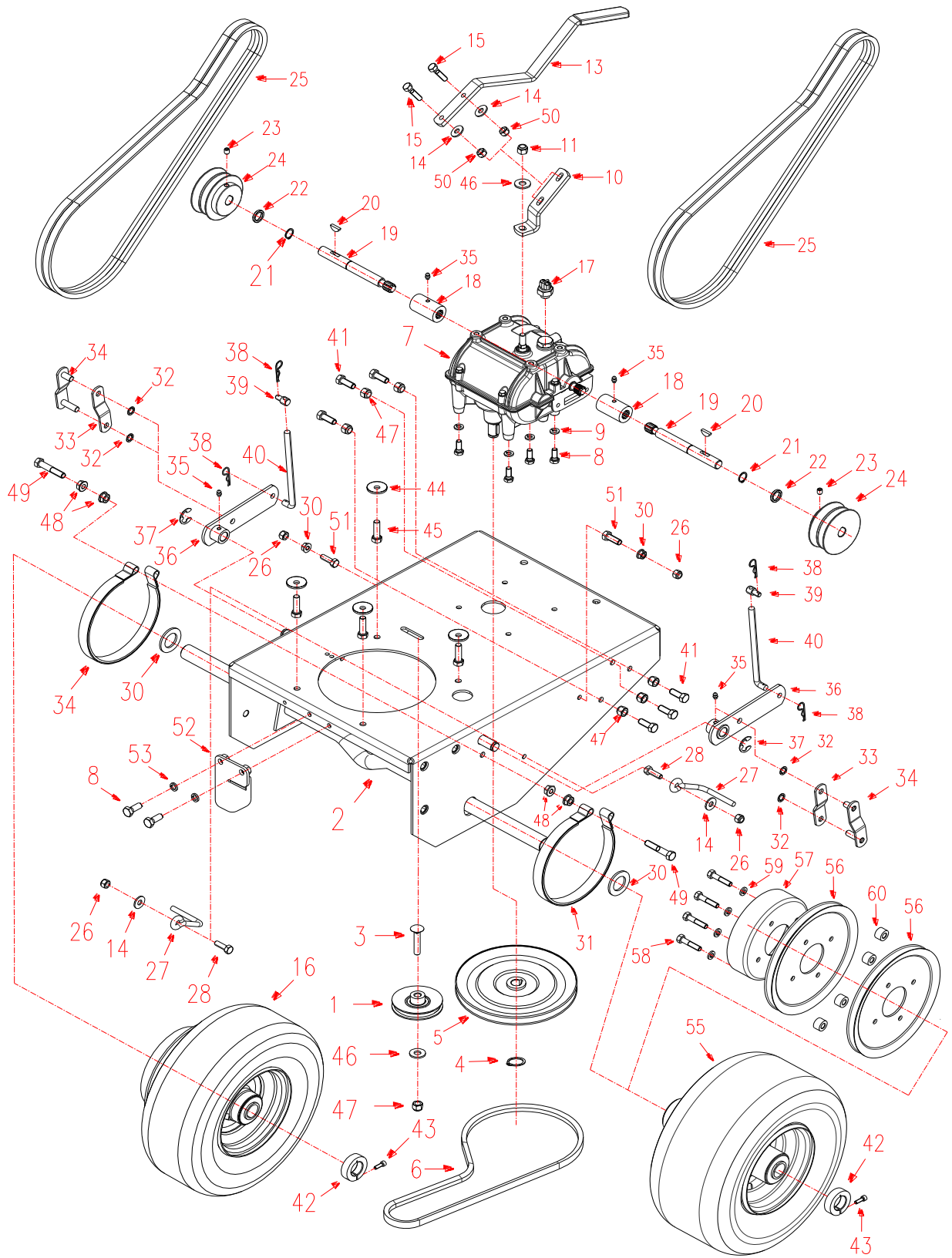



REAR DECK ASM, 36"/48" BELT

ITEMS	PART NO.	DESCRIPTION	ITEMS	PART NO.	DESCRIPTION
1	363169	SMALL IDLER	31	363176	6" BRAKE BAND
2	482062	DECK WMT, 36/48 BELT REAR	32	363177	3/8 PUSH NUT
3	107501	3/8-16 X 2 CARR. BOLT	33	363135	BRAKE CONNECTOR
4	108508	EXTERNAL SNAP RING 5/8	34	362026	BRAKE CONNECTOR ASSY
5	363220	TRANSMISSION SHEAVE	35	111004	1/4-28 ZERK
6	363212	TRANSMISSION BELT	36	362042	LT BRAKE ARM ASM
7	363430	TRANSMISSION, 5 SP WALK	37	108500	E-RING 5/8 DIA.
8	B5783-820	SCREW, HH TAP M8x20	38	363165	#3 HAIRPIN COTTER
9	105005	5/16 LOCKWASHER-HEAVY	39	323029	32" SQUARE BUMPER
10	363128	SHIFTER BRKT	40	363142	BRAKE LINKAGE
11	104251	3/8-24 NYLOC NUT	41	100292	3/8-16 X 1 HHCS
12	105260	3/8 STD FLAT WASHER	42	363145	CLAMP COLLAR
13	362060	SHIFTER LEVER W/GRIP	43	B70.1-510	CAP SCREW, 5 X 10 HEX
14	105258	5/16 STD FLAT WASHER	44	753027	SPRING DISC WASHER
15	100274	5/16-18 X 1-1/4 HHTB	45	100293	3/8-16 X 1-1/4 HHCS
16	362048	DRIVE WHEEL ASSY-PUR	46	105260	3/8 STD FLAT WASHER
17	463128	TRANSMISSION SWITCH	47	104257	3/8-16 HEX NYLOC NUT
18	362086	9 SPL. COUPLER W/ZERK	48	109007	3/8-16 WHIZLOCK NUT
19	363367	SHAFT EXTENSION - 9SPL.	49	100296	3/8-16 X 2 HHCS
20	107009	3/4 X 3/16 WOODRUFF KEY	50	104256	5/16-18 HEX NYLOC
21	108508	EXTERNAL SNAP RING 5/8	51	100273	5/16-18 X 1 HHCS
22	363087	TRANS SHAFT SPACER	52	452186	WLD, CLUTCH TORSION
23	103293	5/16-18 X 3/8 SETSCREW	53	B93-8	LOCKWASHER 8
24	363137	2-GROOVE SHEAVE	54	362041	RT BRAKE ARM ASM
25	363312	2PC WHEEL DRIVE BELT SET	55	362055	TIRE
26	104256	5/16-18 HEX NYLOC NUT	56	363191	PULLEY
27	363075	ROUND BELT GUIDE	57	363190	PULLEY FRAME
28	100273	5/16-18 X 1 HHCS	58	100275	5/16-18X1-1/2 HHCS
29	109001	5/16-18 WHIZLOCK NUT	59	105005	5/16 LOCKWASHER-HEAVY
30	363121	WHEEL WASHER	60	363113	WHEEL PULLEY SPACER

HANDLE ASM, BELT LOWER

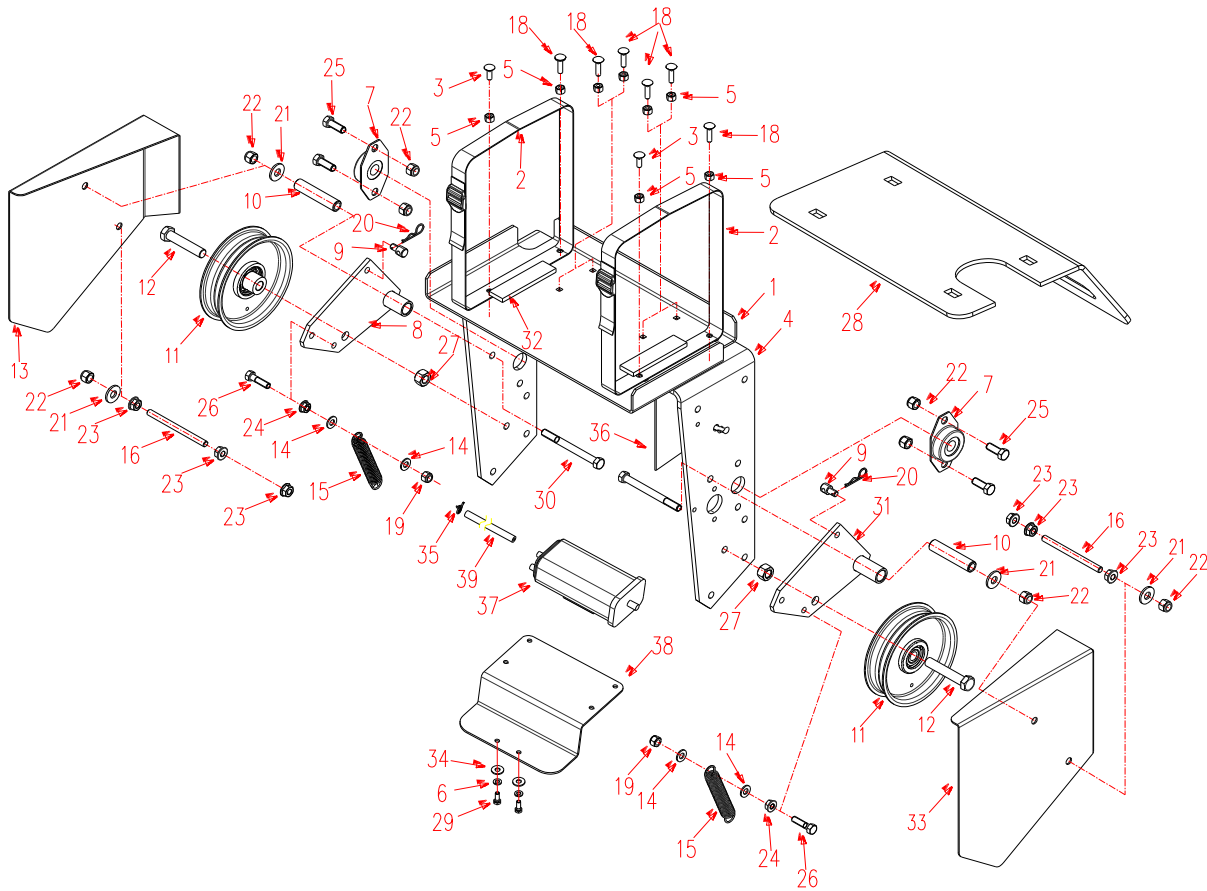

ITEMS	PART NO.	DESCRIPTION	ITEMS	PART NO.	DESCRIPTION
1	363420	FUEL TANK MNT - PAINTED	21	105260	3/8 STD FLAT WASHER
2	363368	GAS TANK BELT	22	104257	3/8-16 HEX NYLOC NUT
3	107502	1/4-20 X 3/4 CARRIAGE BOLT	23	109007	3/8-16 WHIZLOCK NUT
4	363148	LOWER HANDLE	24	109001	5/16-18 WHIZLOCK NUT
5	104255	1/4-20 HEX NYLOC NUT	25	100292	3/8-16 X 1 HHCS
6	105004	1/4 LOCKWASHER	26	100274	5/16-18 X 1-1/4 HHTB
7	363292	FLANGED BEARING	27	104259	1/2-13 HEX NYLOC NUT
8	362037	RIGHT IDLER ARM	28	363224	TANK SADDLE
9	363029	.312 ROD SWIVEL	29	B5783-616	SCREW, HH TAP M6X16
10	363105	IDLER BUSHING	30	100303	3/8-16 X 4 HHCS
11	363168	DRIVE IDLER	31	362035	LEFT IDLER ARM
12	100331	1/2-13 X 2-1/2 HHCS	32	363201	FUEL TANK PAD
13	363286	FENDER RH	33	363288	FENDER LH
14	105257	5/16 SAE FLAT WASHER	34	105256	WASHER, FLAT
15	363117	BELT TENSION SPRING	35	363098	CLAMP, FUEL LINE
16	363093	SAFETY SHIELD SUPPORT	36	363416	LABEL, EPA-WB
17	362036	LEFT IDLER ARM	37	363423	SM CARBON CANISTER
18	107510	1/4-20 X 1 CARRIAGE BOLT	38	363426	CARBON CANISTER MT
19	104256	5/16-18 HEX NYLOC NUT	39	603032	FUEL LINE, 16 & 18 BRIGGS
20	363165	#3 ISSCO HAIRPIN COTTER			

HANDLE ASM, UPPER B-D

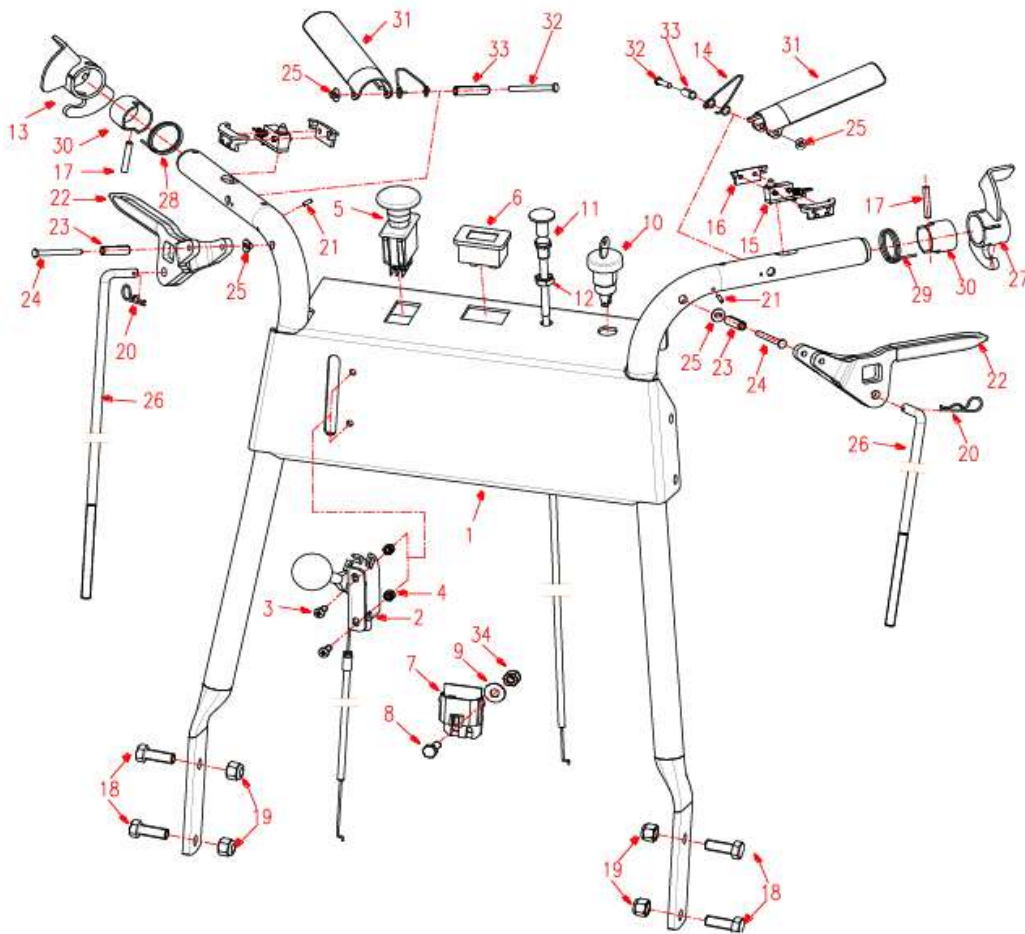

ITEMS	PART NO.	DESCRIPTION	ITEMS	PART NO.	DESCRIPTION
1	452169-1	HANDLE, CONSOLE - BLK	19	104257	3/8-16 HEX NYLOC NUT
2	453531	CABLE, THROTTLE	20	363165	#3 ISSCO HAIRPIN COTTER
3	B823-514	SCREW, PAN HD M5 X 14	21	B879-38	PIN, 3 X 8 ROLL
4	B6182-5	NUT, NYLOC M5	22	454117	LEVER, TRACTION SPEED
5	523031	PTO SWITCH	23	106340	5/16 X 1 ROLL PIN PLTD
6	453417	METER, MS HOUR	24	363073	TRACTION LEVER PIN
7	363372	SAFETY MODULE - WB	25	363219	3/16 PALNUT
8	100252	1/4-20 X 3/4 HHCS	26	363453	ROD, DRIVE CONTROL
9	105256	1/4 STD FLAT WASHER	27	322022-1	LOCK WMT, LH BELT
10	603060	RUN/STOP SWITCH	28	3206011	TORSION SPRING, RIGHT
11	523037	CHOKE CABLE	29	3206010	TORSION SPRING, LEFT
12	104754	3/8-24 HEX JAM NUT	30	3206033	BUSHING
13	322023-1	LOCK, RH BELT - BLK	31	453581	LEVER, OPC PALM
14	453585	SPRING, OPC PALM LEVER	32	453520	PIN, OPC LEVER PIVOT
15	453588	MODULE, OPC SWITCH	33	106342	5/16 X 1-1/4 ROLL PIN
16	453579	HOUSING, OPC SWITCH	34	104255	1/4-20 HEX NYLOC NUT
17	B879-318	PIN 3X18			
18	100292	3/8-16 X 1 HHCS			

YOKE CASTER COMPLETE

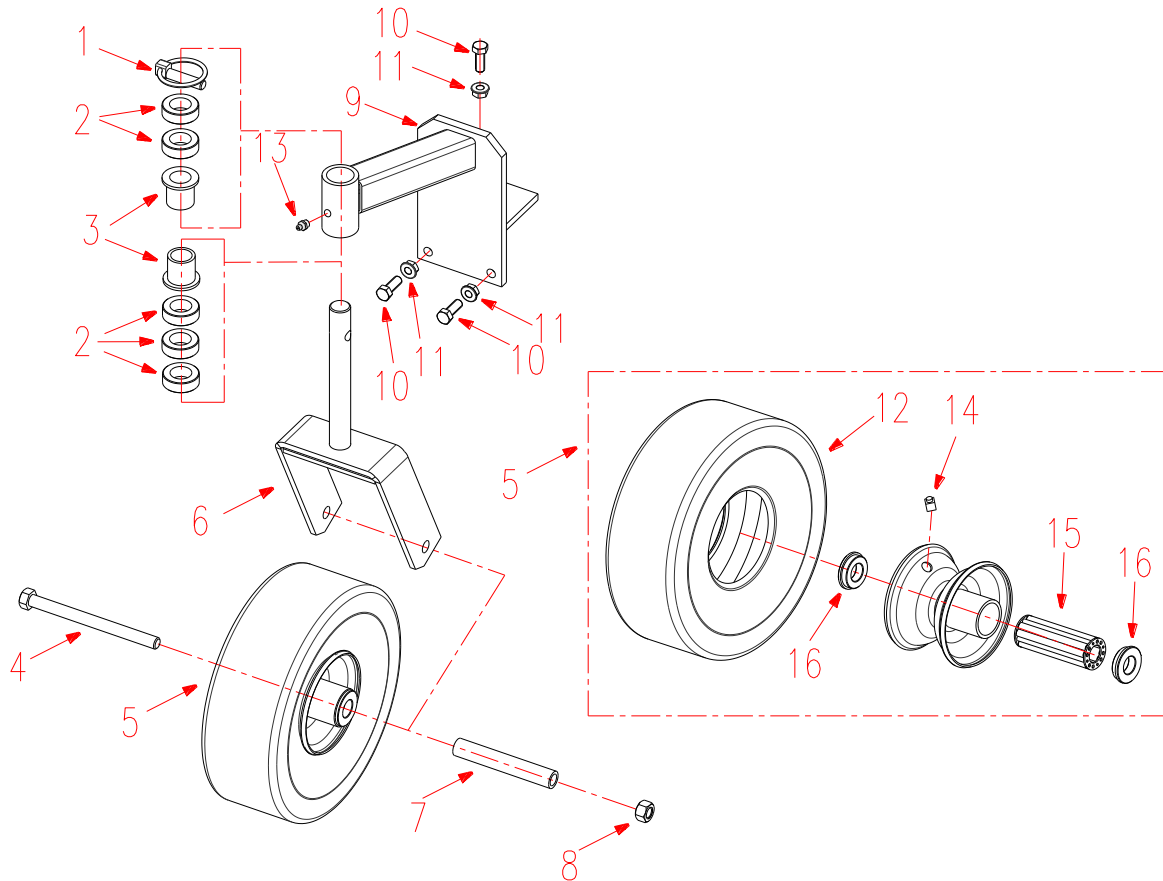

ITEMS	PART NO.	DESCRIPTION
1	109020	7/16 X 1-3/4 QUICK PIN HD
2	363006	10" CASTER SPACER
3	363007	FLANGE BEARING
4	100339	1/2-13 X 6 HHCS
5	363311	10" CASTER WHEEL
6	362081	YOKE-STRUT WLDMT
7	363307	AXLE TUBE
8	104259	1/2-13 HEX NYLOC NUT
9	362007	CASTER SUPPORT W/ BUSHING
10	100292	3/8-16 X 1 HHCS
11	109007	3/8-16 WHIZLOCK NUT
12	363360	TIRE Tube
13	111001	GREASE ZEAK
14	111005	GREASE ZEAK
15	423200	WHEEL HUB BEARING
16	423201	BEARING RETAINER

ASM, 32" 36" RUBBER DEFLECTOR

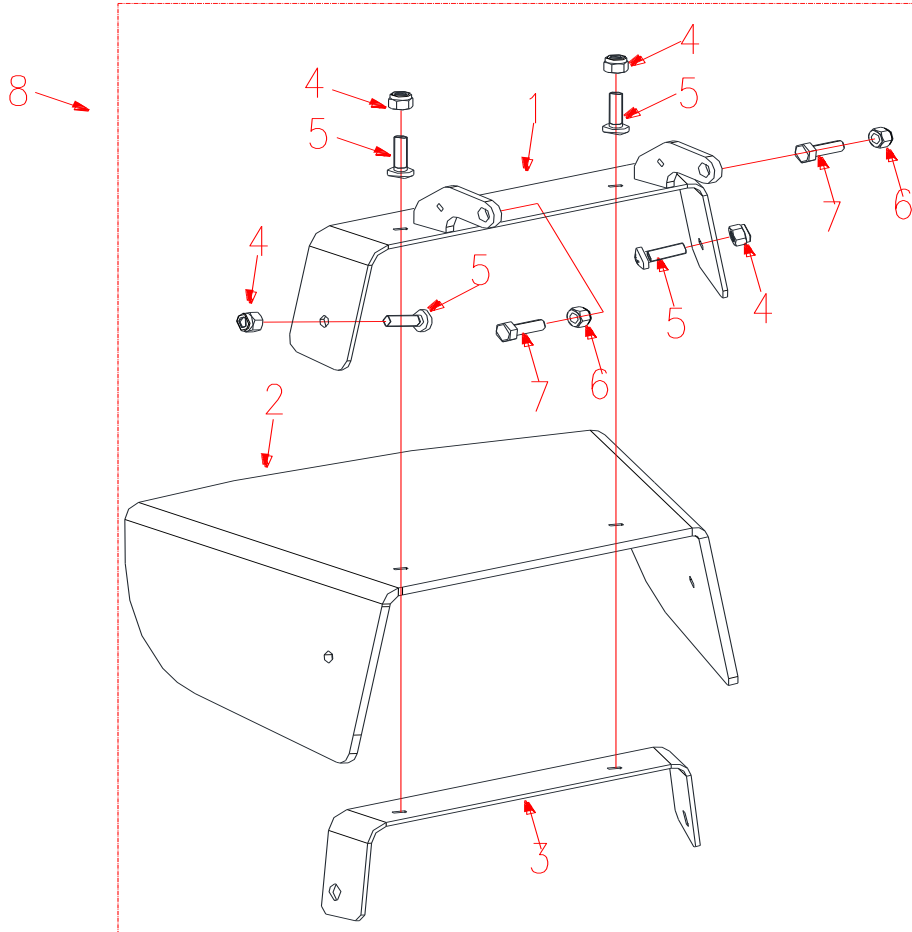

ITEMS	PART NO.	DESCRIPTION
1	482058-2	WLD, DEFLECTOR BRACKET
2	483118	RUBBER SHEET
3	483130-2	36 INSIDE DEFLECTOR BRACKET - RED
4	B6182-8	NUT, NYLOC M8
5	B818-825	SCREW, M8X25 PHILLIPS PAN
6	104256	5/16-18 HEX NYLOC NUT
7	100273	5/16-18 X 1 HHCS
8	482059	ASM, RUBBER DEFLECTOR

ASM, 48" RUBBER DEFLECTOR

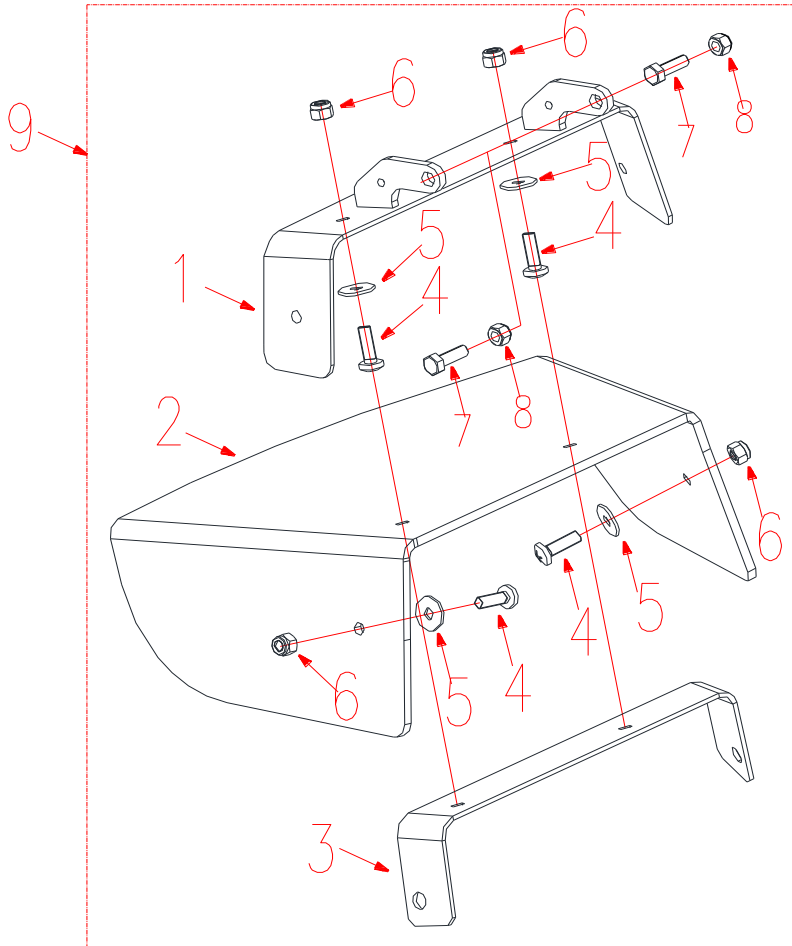

ITEMS	PART NO.	DESCRIPTION
1	482071-2	48" DEFLECTOR BRACKET - RED
2	483132	48" RUBBER SHEET
3	483133-2	48" INSLDE DEFLECTOR BRACKET - RED
4	B818-825	SCREW, M8X25 PHILLIPS PAN
5	B96-8	WASHER 8
6	B6182-8	NUT, NYLOC M8
7	100273	5/16-18 X 1 HHCS
8	104256	5/16-18 HEX NYLOC NUT
9	482072	ASM,48 RUBBER DEFLECTOR

POWER ASM, FS481V BELT

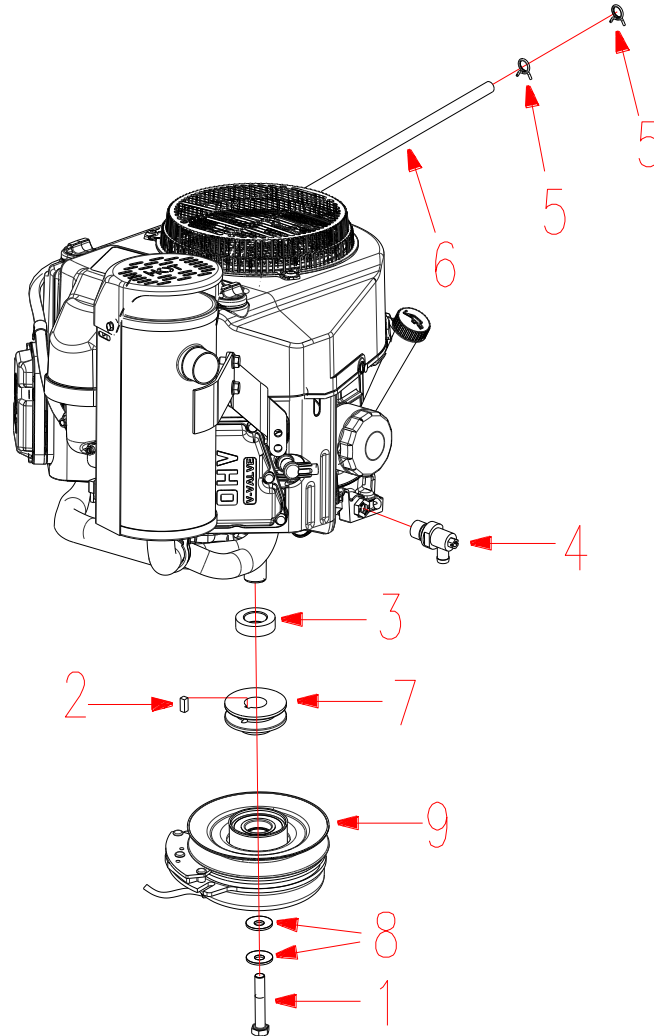

ITEMS	PART NO.	DESCRIPTION
1	100535	7/16-20 X 2-1/2 HHCS
2	107257	1/4 X 1/4 X 5/8 MACH KEY
3	583110	PULLEY SPACER
4	343146	90 DEGREE DRAIN
5	363098	CLAMP, FUEL LINE 1/4 ID
6	363099	LONG FUEL LINE
7	363119	TRANSMISSION PULLEY
8	423069	SPRING DISC. - 7/16
9	453478	CLUTCH, ELECTRIC BRAKE

FIVE GALLON FUEL TANK ASM

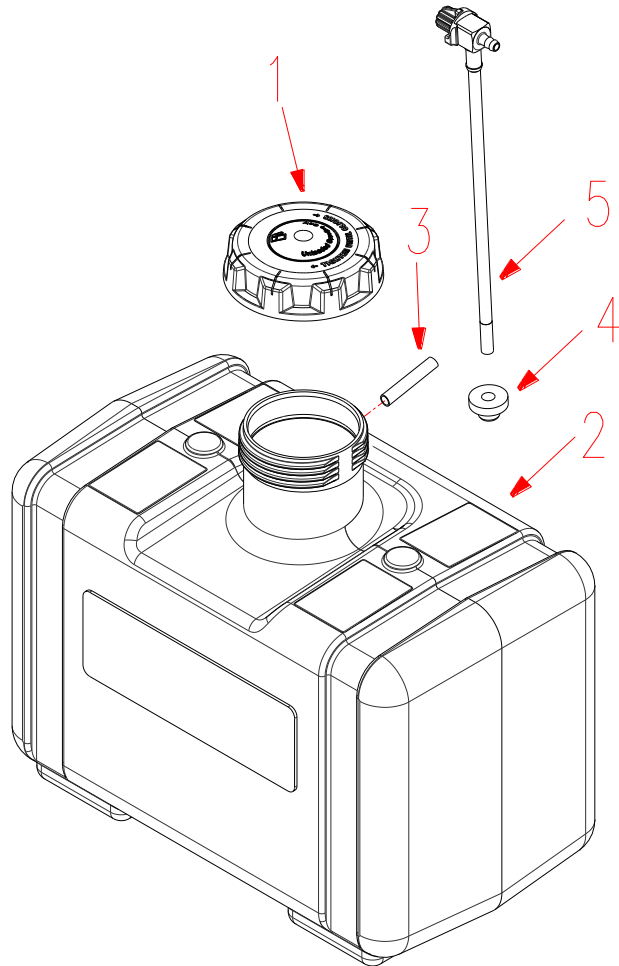

ITEM	PART NO.	DESCRIPTION
1	5204019	Fuel Tank Cap
2	363410	Fuel Tank, ASM.
3	4805004	VENT VALVE
4	533125	GROMMET
5	363418	FUEL VALVE

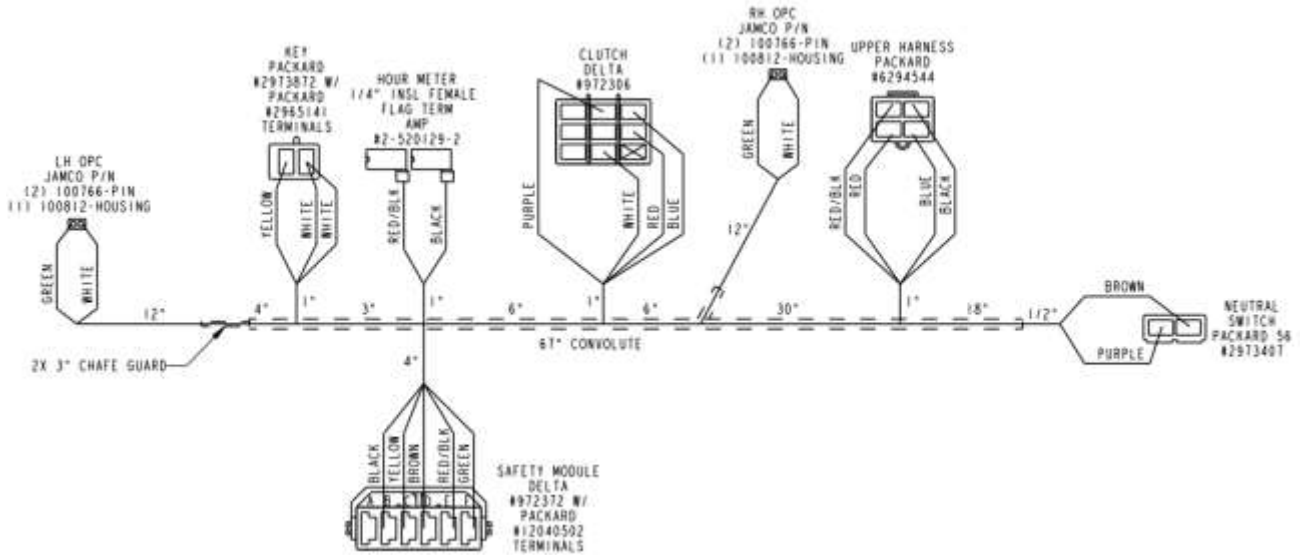

1

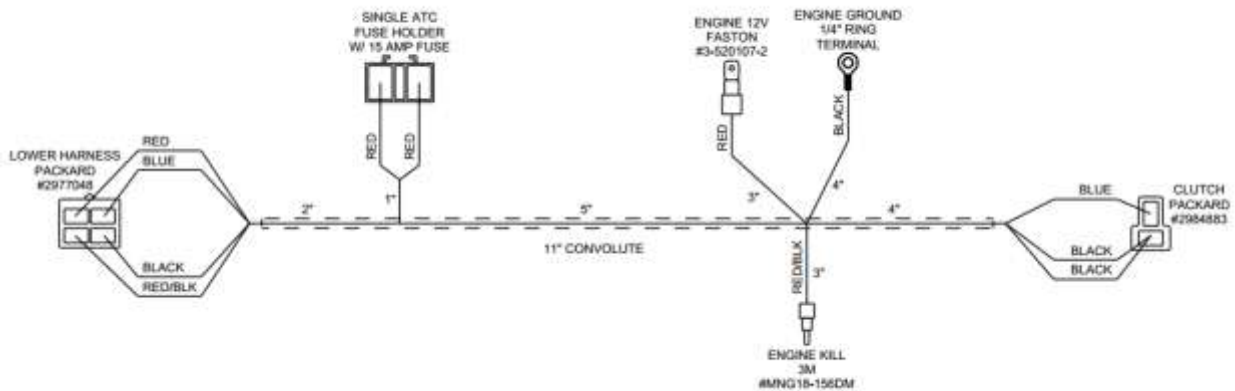









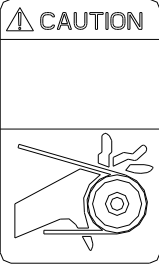

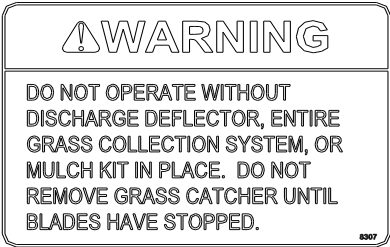
2

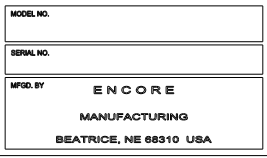
ITEMS	PART NO.	DESCRIPTION
1	323049	HARNESS, B-DRIVE
2	323051	HARNESS, ENGINE WIRE

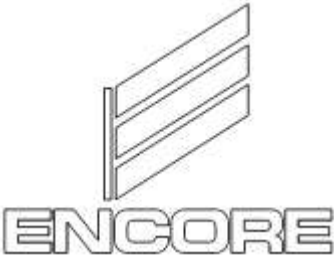
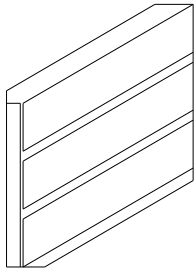
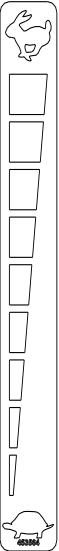
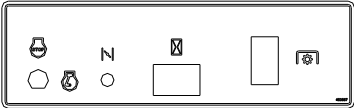
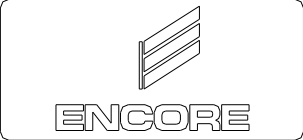
DECAL



 <p>1</p>	 <p>2</p>	 <p>3</p>	
 <p>4</p>	 <p>5</p>	 <p>6</p>	
 <p>7</p>	 <p>10</p>	 <p>11</p>	
<p>R N 1 2 3 4 5</p> <p>8</p>			
<p>OPERATOR MUST DISENGAGE CLUTCH BEFORE SHIFTING GEARS</p> <p>9</p>			
 <p>12</p>	 <p>13</p>	 <p>14</p>	<p>IMPORTANT EMISSION CONTROL INFORMATION WORLDRAWN POWER EQUIPMENT - THIS EQUIPMENT MEETS - U.S. EVAPORATIVE EMISSIONS STANDARDS (DOES NOT MEET CARB EVAP STANDARDS)</p> <p>363416</p> <p>15</p>
 <p>16</p>	 <p>17</p>	 <p>18</p>	

ITEMS	PART NO.	DESCRIPTION	ITEMS	PART NO.	DESCRIPTION
1	8008	DECAL, CAUTION, GUARDING LG	10	453570	DECAL, 10" ENCORE LOGO
2	363038	CAUTION INST. LABEL	11	363362	ENCORE LOGO
3	8307	DECAL, DISCHARGE WARNING	12	453564	DECAL, THROTTLE
4	363023	DANGER DECAL, HANDS AND FEET	13	453567	DECAL, CONTROL CONSOLE
5	363026	SERIAL NO. PLATE	14	453563	DECAL, EN HANDLE
6	8303	DECAL, CAUTION, GUARDING SM	15	363416	EPA LABEL - WB
7	363243	SMALL ENCORE LABEL	16	323038	PRO-32 DECAL
8	363241	GEARSHIFT LABEL (RN12345)	17	363356	PRO-36 DECAL
9	363233	SHIFTING LABEL	18	483075	PRO-48 DECAL



ALL RIGHTS RESERVED
CONTENTS SUBJECT TO CHANGE

EW32FS481V EW36FS481V EW48FS481V PARTS MANUAL
BELT DRIVE WALK BEHIND 20160825