

OWNER'S MANUAL

How to maintain and operate your
EcoWater birm filter with air injected assembly
and turbine initiated flow switch



A Marmon Water/Berkshire Hathaway Company

**MODEL
ETF AIIF10**

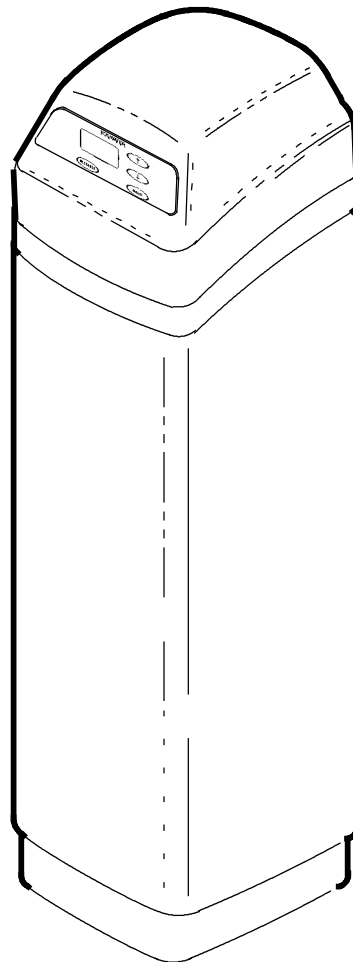

EcoWater Systems
P.O. Box 64420 St. Paul MN 55164 - 9888
(651) 739-5330

UNPACKING

TABLE OF CONTENTS

EcoWater Air Injected Iron Filters are shipped from the factory with the following:

- Filter assembly, packed with quartz and birm ◆
- Air pump
- Relay box assembly
- Transformer
- Parts bag

Thoroughly check the filter for possible shipping damage and parts loss. Also inspect and note any damage to the shipping carton. Notify the transportation company if damage is present. EcoWater is not responsible for in-transit damages.

Remove and discard (RECYCLE) all packing materials.

	PAGE
Safety Guides	3
Specifications / Dimensions	4
Typical Finished Installation	5
Planning Installation	6
Installation	7 - 10
Programming Face Plate Timer	11 - 12
Start Up Checklist	13
Features / Options	14
Filter Operation	15 - 16
Service Information	17 - 19
Repair Parts	20 - 23
Warranty	24

◆ **NOTE:** Do not backwash this unit for 24 hours. The birm will initially retain large amounts of air. If it is backwashed before the air is removed, the valve may get plugged with birm particles, or particles may get flushed to the drain.

SAFETY GUIDES

Follow the installation instructions carefully. Failure to install the filter properly **voids the warranty**.

Before you begin installation, read this entire manual. Then, obtain all the materials and tools you will need to make the installation.

Check local plumbing and electrical codes. The installation must conform to them.

NOTE: Codes in the state of Massachusetts require installation by a licensed plumber. For installation, use plumbing code 248-CMR of the Commonwealth of Massachusetts.

Use only lead-free solder and flux for all sweat-solder connections, as required by state and federal codes. Use care when handling the filter. Do not turn upside down, drop, or set on sharp protrusions.

Do not locate the filter where freezing temperatures occur. Do not attempt to filter water over 120°F. **Freezing, or hot water damage voids the warranty.**

Avoid installing in direct sunlight. Excessive sun heat may cause distortion or other damage to non-metallic parts.

The filter requires a **minimum water flow of 5 gallons per minute** at the inlet for *backwash*. Test water flow if in doubt.

Recommended maximum allowable inlet water pressure is 80 psi. Use a pressure reducing valve if necessary. Be sure the addition of a pressure reducing valve will not reduce the flow to less than the 5 gallons per minute needed for backwash.

This filter controller works on 24 Volt, 60 Hz electrical power only. Be sure to use the included transformer and plug it into a nominal 120V, 60 cycle household outlet that is grounded and properly protected by an over current device such as a circuit breaker or fuse. If transformer is replaced, use only the authorized service, class II, 24 Volt, 10 VA transformer. The relay box for the air pump must be plugged into a separate 120V grounded household outlet.

This system is not intended to be used for treating water that is microbiologically unsafe or of unknown quality without adequate disinfection before or after the system.



European Directive 2002/96/EC requires all electrical and electronic equipment to be disposed of according to Waste Electrical and Electronic Equipment (WEEE) requirements. This directive or similar laws are in place nationally and can vary from region to region. Please refer to your state and local laws for proper disposal of this equipment.

BIRM FILTER WITH AIR INJECTION ASSEMBLY

Filter Type	Oxidizing	Minimum Water Supply pH	7.0
Type of Mineral	Birm	Maximum Service Flow	5.0 gpm
Amount of Mineral	1 cu ft	Minimum Backwash Flow ①	5.0 gpm
Amount of Gravel	17 lbs	Minimum In-Out Pipe Size	3/4 in.
Recommended Maximum Water Supply Pressure	80 psi	Electrical: Filter Timer	24V, 60Hz
Maximum Water Temperature ...	120° F	Electrical: Air Pump	120V, 60Hz

Contaminant Removal Limitations: up to 10 ppm iron.

① **A minimum flow of 5 gpm is required for filter backwash.**

Nominal Mineral Tank Size	10" dia. by 47" high
----------------------------------	----------------------

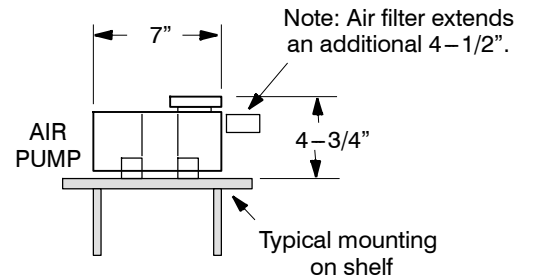
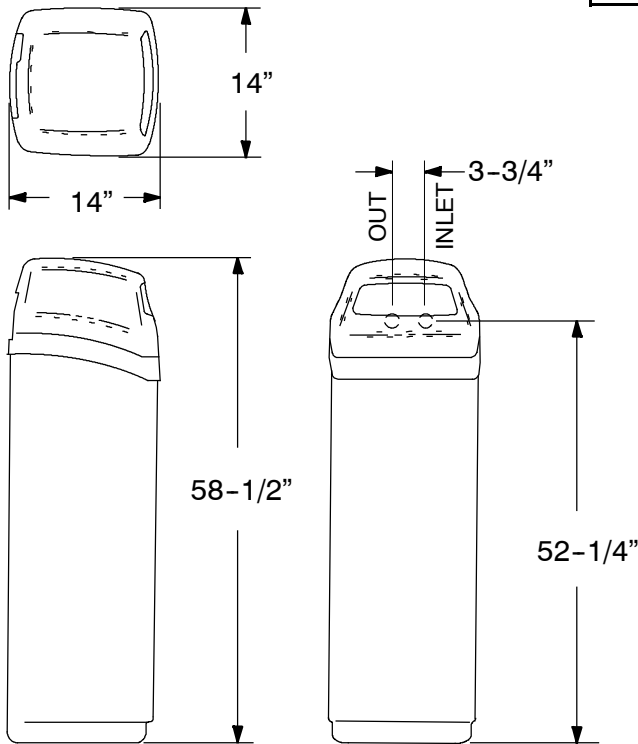

FIGURE 1

TYPICAL FINISHED INSTALLATION

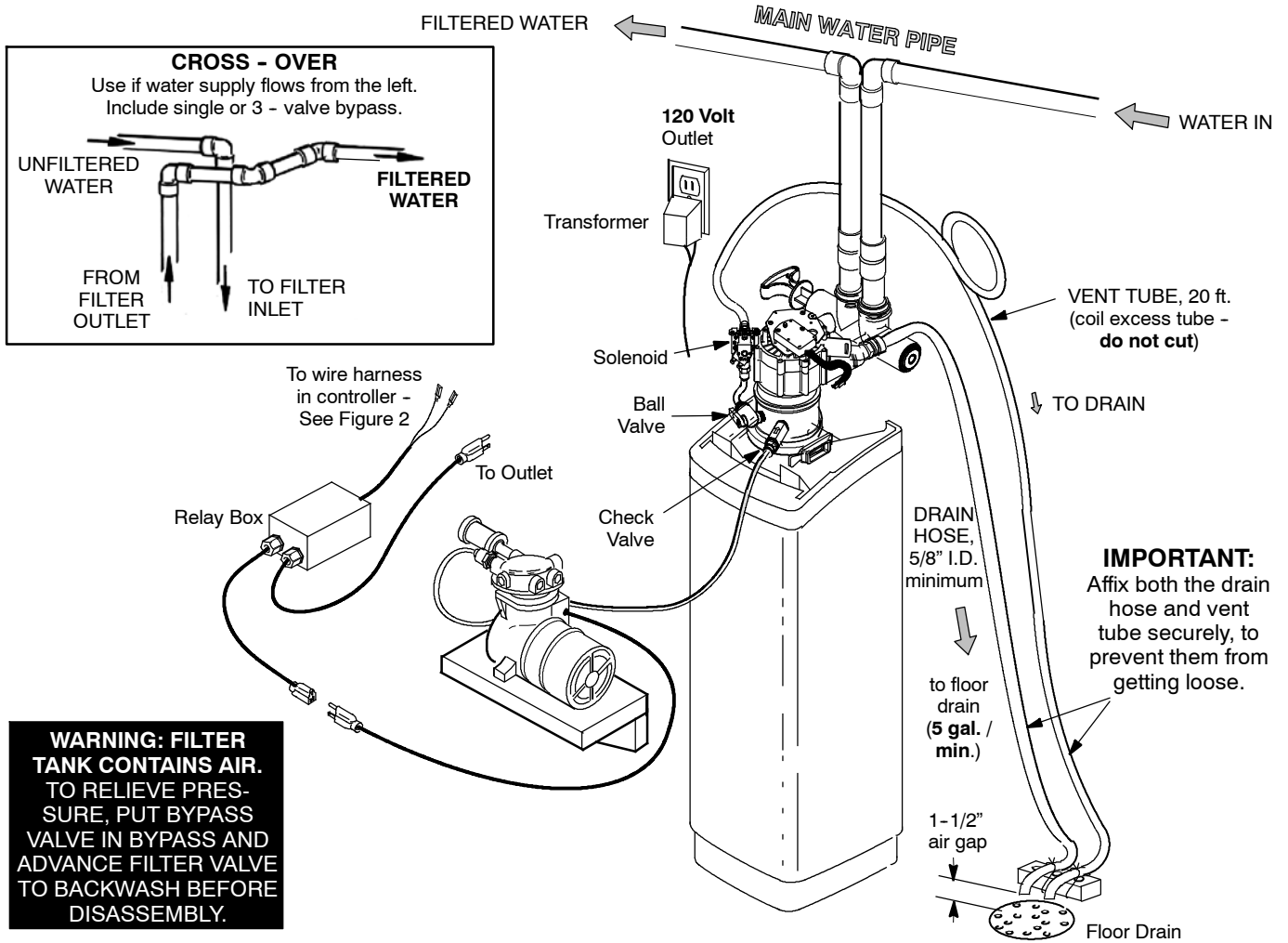
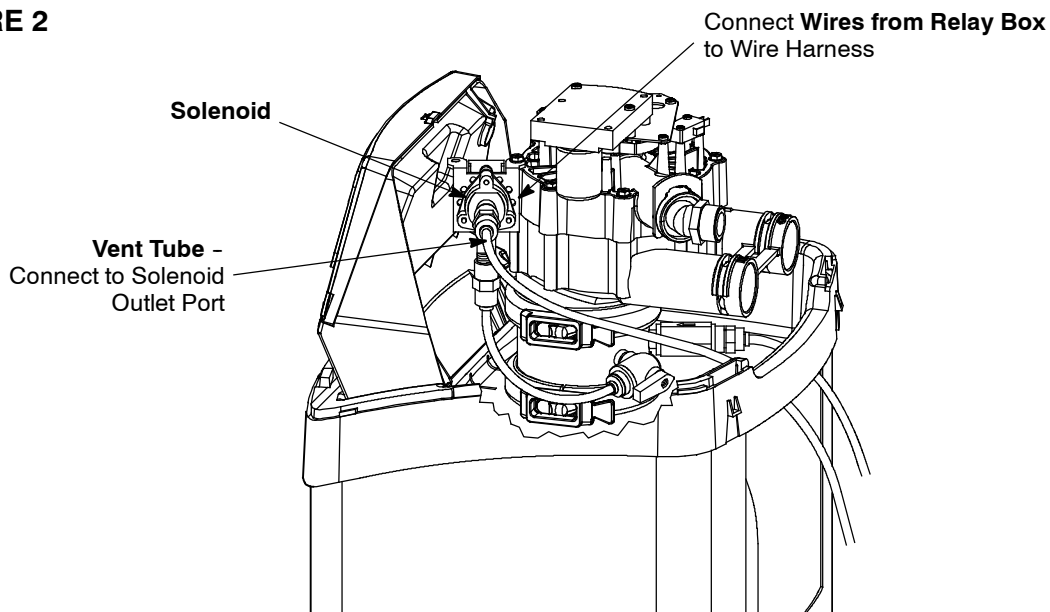

FIGURE 2







INLET - OUTLET PLUMBING OPTIONS

1. ALWAYS INSTALL either an EcoWater bypass valve, #7214383, or a 3 valve bypass system.
2. Use 1" ... or, 3/4" (minimum) pipe and fittings.
3. Use sweat copper... or, threaded pipe*... or, PVC plastic pipe.*

*Sweat soldering is required to adapt to the fittings (1" male) supplied with the filter, or obtain approved compression adaptors. The following special fittings are available from EcoWater. **Be sure to comply with all local plumbing codes.**

OPTIONAL INLET/OUTLET FITTINGS

-  — #7104546 PVC Nipple – Use in place of included copper inlet and outlet tubes.
-  — #7129211 Adaptor Fitting, 1-1/2" (2) – Use in place of included copper inlet and outlet tubes.
-  — #7120259 Elbow – Extends inlet and/or outlet in any 90° direction.
-  — #7271204 Adaptor, 1" NPT (2) – Use in place of included copper inlet and outlet tubes.

OTHER REQUIREMENTS

4. A drain is needed for recharge discharge water. A standpipe, close to the filter is preferred. A laundry tub, floor drain, etc., are other options.

CAUTION: DRAIN WATER EXITS THE HOSE AT A FAST FLOW RATE, AND AT WATER SYSTEM PRESSURE. BE SURE THE HOSE IS FASTENED IN SOME MANNER TO PREVENT "WHIPPING", AND SPLASHING TO PREVENT WATER DAMAGE TO SURROUNDING AREA.

5. A 120V, 60Hz, grounded electrical outlet (continuously "live") is needed within 10' of the filter.

TOOLS YOU MAY NEED

- common screwdriver
- cross-point screwdriver
- pliers
- tape measure

SOLDERED COPPER	THREADED	CPVC PLASTIC
● tubing cutter	● hacksaw or pipe cutter	● hacksaw
● propane torch	● threading tool	● adjustable wrench
● LEAD-FREE solder and flux	● pipe joint compound	● solvent cement
● emery cloth, sandpaper or steel wool		● primer

MATERIALS YOU MAY NEED

- bypass valve, or 3 valves
- pipe and fittings as required
- 5/8" I. D. minimum drain hose, either standard garden hose, or hose onto a barb fitting*

***VALVE DRAIN OPTIONS:** Flexible drain hose is not allowed in all localities (check your codes). For a rigid valve drain run, plumb according to local codes. To connect to the valve drain fitting, purchase an adaptor, garden hose thread x 5/8" (minimum) tube. Use a hacksaw to cut barbs from the fitting.

SELECT INSTALLATION LOCATION

Consider all of the following when selecting an installation location for the filter selected.

- To filter all water in the home, install the filter close to the water supply inlet. To conserve filtered water, outside faucets should remain on raw water.
- If other water conditioning equipment is installed, locate as shown in Figure 3.
- A nearby drain is needed to carry away recharge discharge water. A standpipe is preferred, with a laundry tub, floor drain, etc., as other options (check your local codes).
- The filter works on 24 volts only. A transformer is included (FOR INDOOR USE) to reduce 120V, 60 Hz house electrical power. Provide an approved, grounded outlet within 10' of the filter. The filter includes a 10' power cable for connection between the transformer and the timer. The relay box also requires a suitable live, grounded outlet.
- Position the filter at least 6" from surrounding walls, or other appliances, to allow access for servicing.
- If installing the filter in an outside location, be sure to provide protection from the elements, contamination, vandalism, and sunlight heat. The sun's heat can melt plastic parts.

FIGURE 3

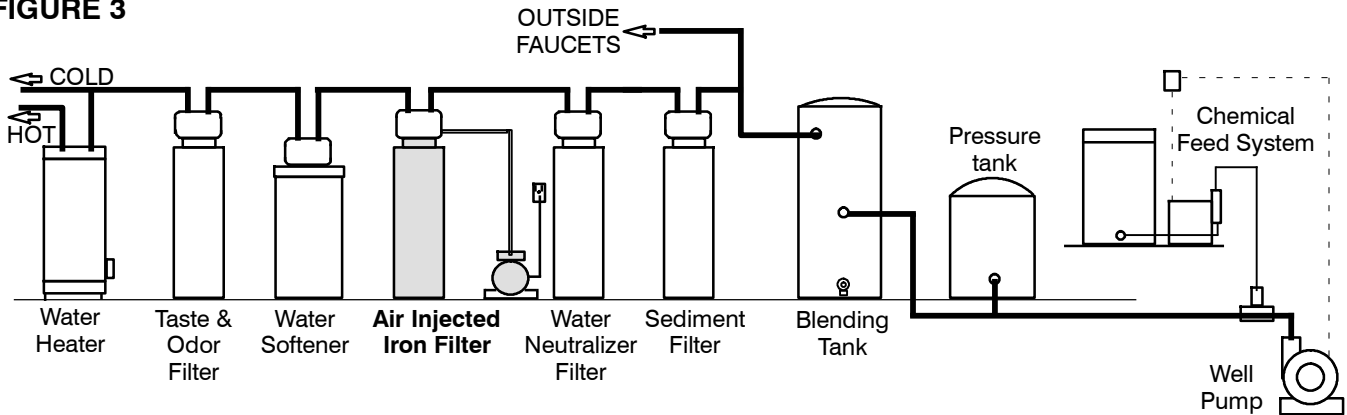

SANITIZING THE FILTER

Care is taken at the factory to keep your water filter clean and sanitary. Materials used to make the filter will not infect or contaminate your water supply, and will not cause bacteria to form or grow; however, during shipping, storage, installing and operating, bacteria could get into the filter. For this reason, sanitizing, as follows, is suggested when installing.

Pour about 1 oz. or 2 oz. of the following disinfectant into the filter.

1. Calcium hypochlorite, available in granular or tablet form, under trade names such as Perchloron or HTH.
2. Common 5.25% household bleach such as Clorox, Linco, Bo Peep, White Sail, Eagle, etc.

SANITIZING WILL BE CONTINUED IN STEP 9, PAGE 11, AND STEP II ON PAGE 12.

1. INSTALL SINGLE BYPASS VALVE and/or COPPER TUBES

NOTE: All fittings are in the parts bag.

a. Push the bypass valve, with lubricated o-ring seals in place, into the valve inlet and outlet ports, Figure 4. Be sure the o-ring sealing surface is clean.

- AND/OR -

b. Slide copper tubes, with lubricated o-ring seals in place, into the filter valve or bypass valve inlet and outlet ports, Figure 5. Be sure the o-ring sealing surface is clean.

NOTE: Be sure the turbine and support are in place in the valve outlet, as shown in Figures 4 and 5.

c. Snap the two large plastic clips into place, from the top down, Figure 4 and Figure 5. Be sure they snap into place. Pull on the copper tubes, or bypass valve, to make sure they are held securely in place.

NOTE: For lubrication, use silicone grease approved for use on potable water supplies.

FIGURE 4

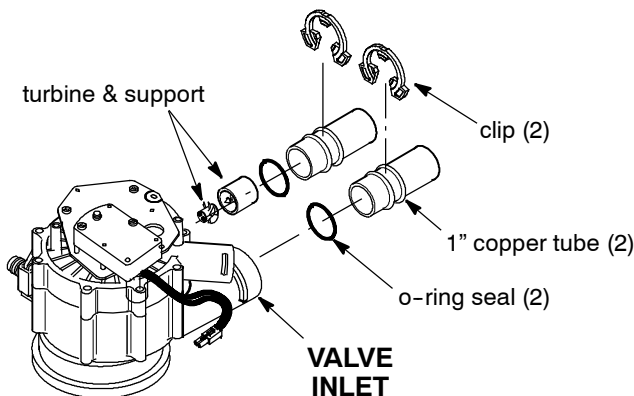
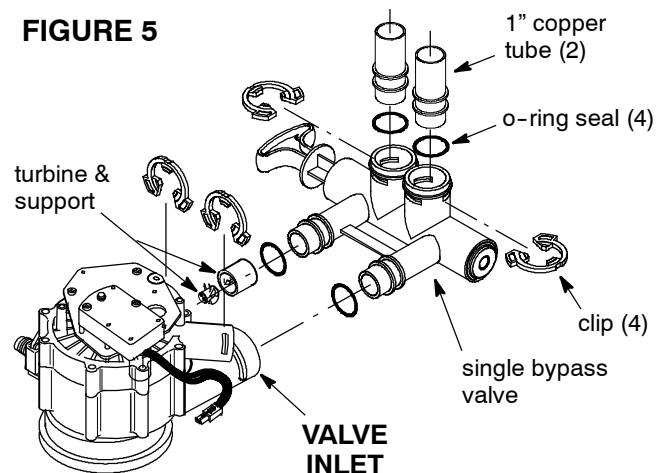

FIGURE 5



2. TURN OFF WATER SUPPLY

- a. Close the main water supply valve, near well pump or water meter.
- b. Shut off the electricity or fuel supply to the water heater.
- c. Open high and low faucets to drain all water from house pipes.

3. INSTALLING 3-VALVE BYPASS

If installing a 3-valve bypass system, plumb as needed. If installing sweat copper, be sure to USE LEAD-FREE SOLDER as required by Federal and State codes. Use pipe joint compound on outside pipe threads.

4. MOVE FILTER INTO PLACE

Move the filter into the installation position, setting on a solid, smooth and level surface.

CAUTION: DO NOT PLACE SHIMS DIRECTLY UNDER THE SHROUD. The weight of the tank may cause the shroud to fracture at the shim.

5. ASSEMBLE INLET & OUTLET PLUMBING

Measure, cut and loosely assemble pipe and fittings from the main water pipe (or from bypass valves installed in step 3), to the filter inlet and outlet copper tubes.

BE SURE UNFILTERED WATER SUPPLY PIPE GOES TO THE FILTER INLET SIDE. Trace the water flow direction to be sure.

6. COLD WATER PIPE GROUNDING

The house cold water pipe (metal only) is often used as a ground for the house electrical system. The 3-valve bypass type, if installed, will maintain

ground continuity. If you use the plastic bypass valve at the filter, continuity is broken. To restore the ground, install one of the following grounds.

- a. Use the included ground clamp kit to jumper across the inlet and outlet copper tubes Figure 6a.
- b. Install a #4 copper wire across the removed section of main water pipe, securely clamping on both ends, Figure 6b.

7. CONNECT INLET & OUTLET PLUMBING

Complete the inlet and outlet plumbing as applicable.

a. SOLDERED COPPER

- (1) Thoroughly clean and flux all joints.
- (2) Remove the inlet and outlet tubes from the valve (pull plastic "C" clips), and o-rings from the tubes. **DO NOT SOLDER WITH TUBES IN THE VALVE. SOLDERING HEAT WILL DAMAGE THE VALVE.**
- (3) Make all solder connections. Be sure to keep fittings fully together, and pipes square and straight.
- (4) **AFTER PLUMBING HAS COOLED**, repeat steps 1b and 1c.

b. THREADED PIPE

- (1) Apply pipe joint compound to all outside pipe threads.
- (2) Tighten all threaded joints.
- (3) If **SOLDERING TO INLET AND OUTLET TUBES**, observe steps (1) through (4) above.

c. CPVC PLASTIC PIPE

- (1) Clean, prime and cement all joints (follow instructions of the plastic pipe and fittings manufacturer).
- (2) **IF SOLDERING TO INLET AND OUTLET TUBES**, observe preceding steps (1) through (4).

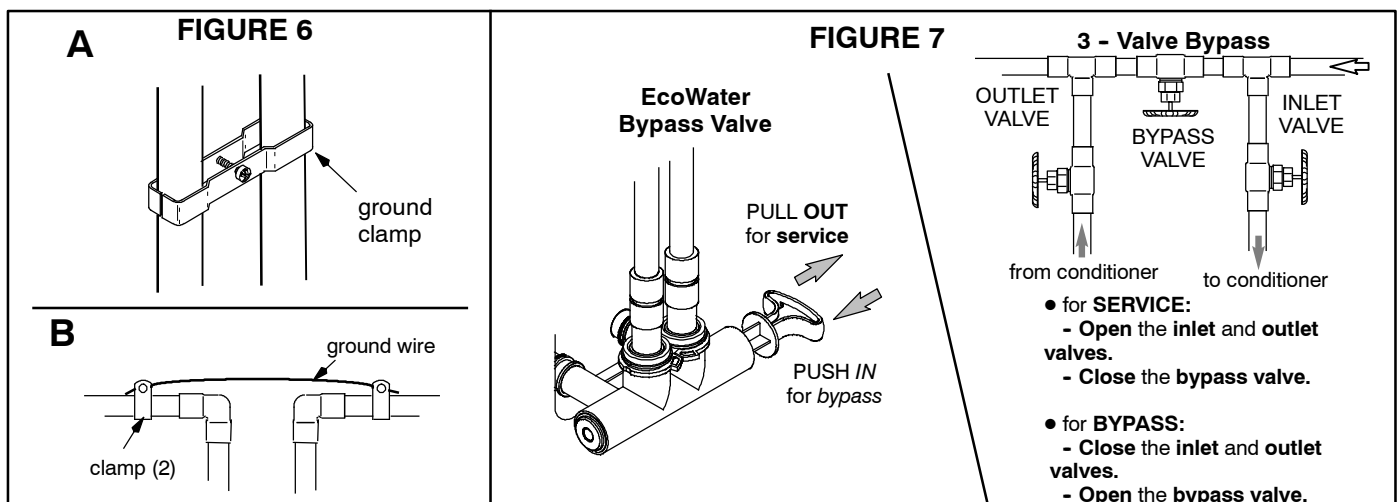

8. INSTALL VALVE DRAIN HOSE

a. Connect a length of 5/8" I.D. (minimum) hose to the valve drain elbow on the controller Figure 1. The elbow accepts standard garden hose onto the threads.

NOTE: Flexible drain hose is not allowed in all localities. See option on page 6.

b. Route the hose to the drain point (standpipe, laundry tub, floor drain, etc.) as typically shown in Figure 1. **Affix the end of the hose securely** to prevent "whipping" during recharges. Be sure to provide a 1-1/2" minimum air gap, to prevent possible sewer water backup.

NOTE: Avoid long drain hose runs, or elevating the hose.

9. INSTALL VENT TUBE

a. Locate the 20' coil of 1/4" O.D. tubing included with the filter. Connect one end of the tubing to the outlet port of the solenoid valve, Figure 2.

NOTE: Do not cut the vent tubing - use the entire 20' length.

b. Route the vent tubing to the drain point (standpipe, laundry tub, floor drain, etc.) as typically shown in Figure 1. **Affix the end of the tube securely**, as water and air will exit this vent with force.

10. PRESSURE TESTING FOR LEAKS

TO PREVENT EXCESSIVE AIR PRESSURE IN THE FILTER AND PLUMBING SYSTEM, DO THE FOLLOWING STEPS IN ORDER

a. Open two or more filtered water faucets, both hot and cold.

b. Referring to Figure 7, turn the bypass valves to service position.

c. Slowly open the main water supply valve.

d. Close the filtered water faucets.

e. Check your complete installation for leaks. If rework is required, be sure to observe precautions in step 6.

11. CONNECT ALL LEADWIRES

a. Locate the power cable, which is shipped with one end plugged into the timer (PWA) under the top cover. Refer to Figure 8. Attach the other end of the power cable to the transformer.

NOTE: Check to be sure the connector is secure on the back of the timer.

b. Plug the leads from the relay box into the corresponding connectors of the wire harness, located near the solenoid under the top cover.

12. CONNECT AIR PUMP

a. On the floor or a shelf nearby the filter, fasten the air pump in place.

b. Install the air filter (if required) and tubing connector fitting.

c. Connect the tubing from the check valve, on the adaptor, to the connector fitting on the air pump.

d. Plug the pump into the relay box connector.

13. CONNECT TO ELECTRICAL POWER

Plug both the transformer and relay box into continuously "live", grounded, 120V, 60Hz house electrical outlets, approved by local codes.

14. TO COMPLETE INSTALLATION, DO THE PROGRAMMING STEPS ON PAGES 11 AND 12.

NOTE: WATER HEATER START-UP ON PAGE 12.

FIGURE 8

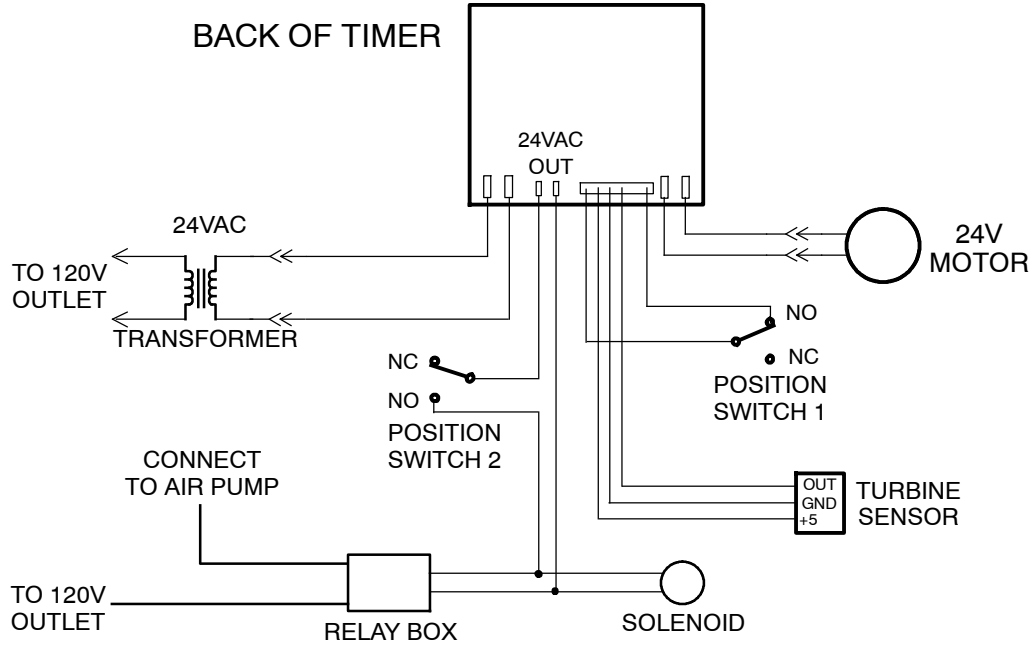
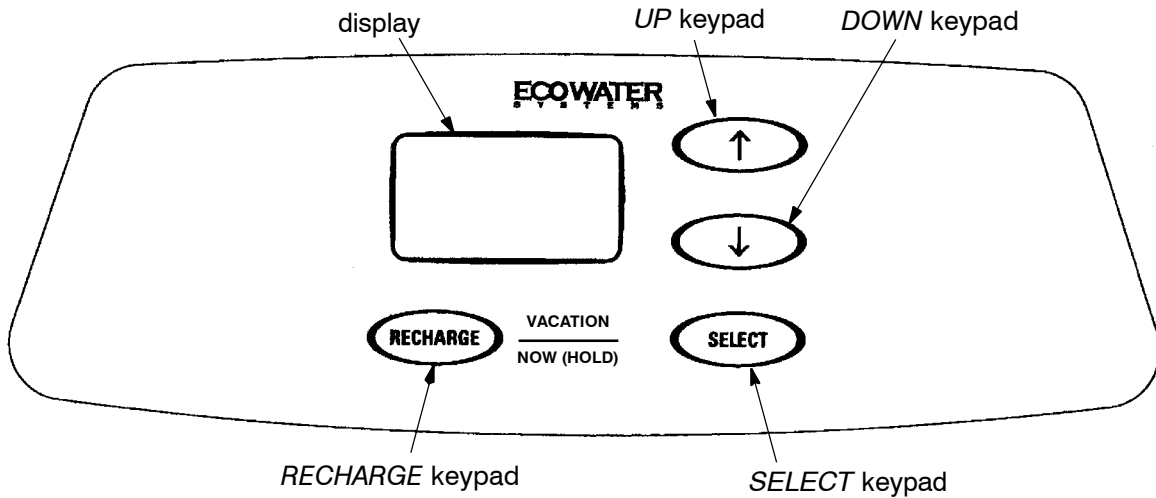
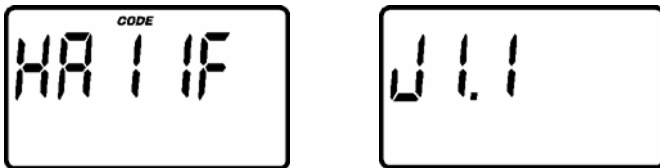

FIGURE 9



I. When the transformer is plugged in, the model code HAIF shows in the face plate display for the first few seconds. The model code is followed by a test number (example: J1.1). Then the display will flash "12:00 PM" and the words "PRESENT TIME". Set the present time of day as follows:



A. Set Time of Day



1. Press the UP or DOWN keypads until the correct time of day shows, being sure AM or PM shows in the display.

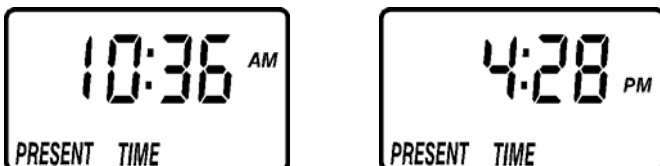

NOTE: Press and quickly release the keypads to slowly advance the display. Hold the kaypads down

for fast advance. This procedure applies for all following settings.

2. Press the SELECT keypad once to set the present time and advance to the next set up screen.

B. Set Days to Recharge

1. This setting is the number of days the filter will go between recharges. The default setting is 3 days, with a maximum setting of 99.

2. Press the UP or DOWN keypads until the correct number of days between recharges is shown in the display.



3. Press the SELECT keypad once to set the days to recharge and advance to the next set up screen.

NOTE: See the chart on the following page to determine the frequency of recharges. Find the number of people living in the household, and then going across the chart, find the amount of iron (in parts per million) that is in the water supply. The number of days that shows is the number of days the filter should be set for recharges.

Number of People	Iron (parts per million)			
	1 - 2	3 - 4	5 - 7	8 - 10
1	4 days	3 days	2 days	1 day
2	4 days	3 days	2 days	1 day
3	4 days	3 days	1 day	1 day
4	3 days	2 days	1 day	1 day
5	3 days	2 days	1 day	1 day
6	2 days	1 day	1 day	1 day
7	2 days	1 day	1 day	1 day

NOTE: If the water supply has high turbidity (sand, silt, sediments, etc.) set the filter to recharge more often than the table above shows.

C. Set Recharge Time

1. Press the UP or DOWN keypads until the correct recharge time shows, being sure AM or PM shows in the display. Default for this display is 12:00 AM.



2. Press the SELECT keypad once to set the days to recharge and advance to the next set up screen.

II. Press and hold the RECHARGE keypad for three seconds until RECHARGE NOW begins to flash in the display, starting a backwash. This backwash

flushes “fines” from the new mineral, and purges air and bleach remaining from the sanitizing procedure. The filter returns to service in about 30 minutes.

III. RESTART THE WATER HEATER: Turn on the electric or fuel supply to the water heater, and light the pilot, if applies.

NOTE: The water heater is filled with unfiltered water and as hot water is used, it refills with filtered water. In a few days, hot water will be fully filtered. To have fully filtered water immediately, wait until the recharge (step II above) is over. Then, drain the water heater until water runs cold.

IV. THE TIMER IS NOW PROGRAMMED AND INSTALLATION IS COMPLETE.

After completing the preceding installation and programming steps, check all the following:

- Make sure the bypass valve(s) are in the “service” position.
- Check for leaks.
- Open a filtered water faucet and confirm that the air pump runs. Pump will run for 8 seconds after water flow has stopped.
- Make sure the ball valve on the neck adaptor is open. See Figure 10.
- Make sure the solenoid vent is open when the air pump is running.
- **Make sure the vent tube is held securely at the drain point. Air/water mixture exits the vent tube with force. Observe the vent tube for at least 10 minutes while air pump is running and solenoid is open to ensure that vent tube is held securely and will not become dislodged from the drain.**

FIGURE 10

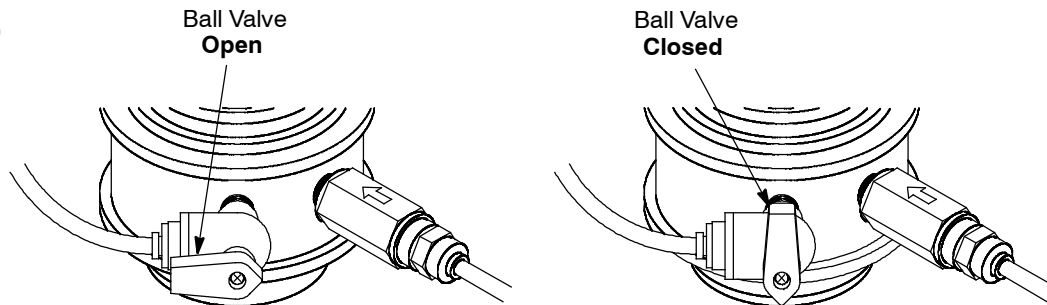

RECHARGE NOW – For an immediate extra backwash at any time, use this feature. Press and **hold** in the RECHARGE keypad for three seconds until RECHARGE NOW begins to flash in the display. The filter backwashes for 25 minutes, followed by a 5 minute fast rinse cycle. Then the filter returns to service.



VACATION – The day you leave on vacation, or other long absence, press (DO NOT HOLD IN) the RECHARGE keypad. **VAC** begins to flash in the display. The timer will keep time, but the filter will not backwash and waste water.



NOTE: While in the VACATION setting, the filter **will** go through a backwash if the RECHARGE NOW feature is used (see above).

WHEN YOU RETURN, press the RECHARGE keypad again to return the filter to service, and the correct time of day will show in the display. **Remember to do this or the filter will not backwash and you will have unfiltered water.**

The default settings for backwash (25 minutes) and fast rinse (5 minutes) cycles of recharge are factory set for maximum performance of the filter. Use the following procedures to check for correct cycle times, or to change if desired. However, only trained technicians should change the time settings.

ADJUSTABLE BACKWASH – Press and hold the SELECT button until the display shows “000--”, then press the SELECT button once to advance to the Backwash time adjust screen.



Using the UP or DOWN buttons, adjust the backwash time from 0 minutes to 60 minutes.

ADJUSTABLE FAST RINSE – Press and hold the SELECT button until the display shows “000--”, then press the SELECT button twice to advance to the Fast Rinse time adjust screen.

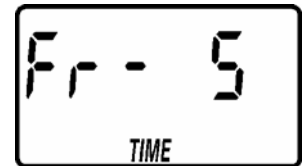

Using the UP or DOWN buttons, adjust the fast rinse time from 0 minutes to 60 minutes.

NOTE: Fill and brine times are adjustable, but preset at the factory to zero minutes. It is recommended to leave these settings as preset, unless the filter is used in a custom application by the installer.

TIMER “POWER-OUTAGE MEMORY” – If electrical power to the timer is interrupted, the “memory” built into timer circuitry keeps time settings for several hours (minimum) or more. The display is blank and the filter will not recharge. When electrical power comes on, one of two things will happen.

1. The present time of day will show steady, meaning the timer has not lost time.
2. The display will show a time, but it will be flashing. The timer memory did **not** keep the time setting and must be reset (page 11). If you do not reset the time setting, recharges will most likely be at the wrong time of day.

NOTE: The flashing display is to remind you to reset the timer.

NOTE: If the filter was in a backwash when power was lost, it will now finish the cycle.

GENERAL INFORMATION

The air injector adaptor installs between the filter valve and mineral tank. A pump injects air into the iron filter through the adaptor. The air oxidizes iron and it is mechanically filtered by the filter mineral bed. The injector adaptor float allows excess air to vent from the tank.

SERVICE, BACKWASH AND FAST RINSE

SERVICE (Figure 11): Unfiltered water enters the valve inlet port. Internal valve porting routes the water down and out the top distributor, into the mineral tank. The water is filtered as it passes through the mineral bed, then enters the bottom distributor. Filtered water flows back into the valve and out the valve outlet, to the house filtered water pipes.

In time, the filter needs cleaning to remove sediments, dirt, iron, etc., from the mineral bed. This

cleaning is done in two stages, or cycles, called backwash and fast rinse. It is started automatically by the timer.

BACKWASH (Figure 12): The timer starts the valve motor and moves the valve into backwash position. Water is routed down and out the bottom distributor, up through the mineral bed, and out the top distributor to the drain. The fast flow (controlled by a flow plug in the drain fitting) flushes dirt, sediments, iron deposits, etc. to the drain. The mineral bed is lifted and expanded for maximum cleaning.

FAST RINSE (Figure 13): Valve rotation positions the inner discs so water flow enters the mineral tank through the top, and exits at the bottom, to the drain. The fast flow of water downward, packs the mineral bed and prepares it for return to service.

The timer energizes the valve motor again to return the valve to service.

WATER FLOW PATHS THROUGH VALVE

FIGURE 11

SERVICE CYCLE

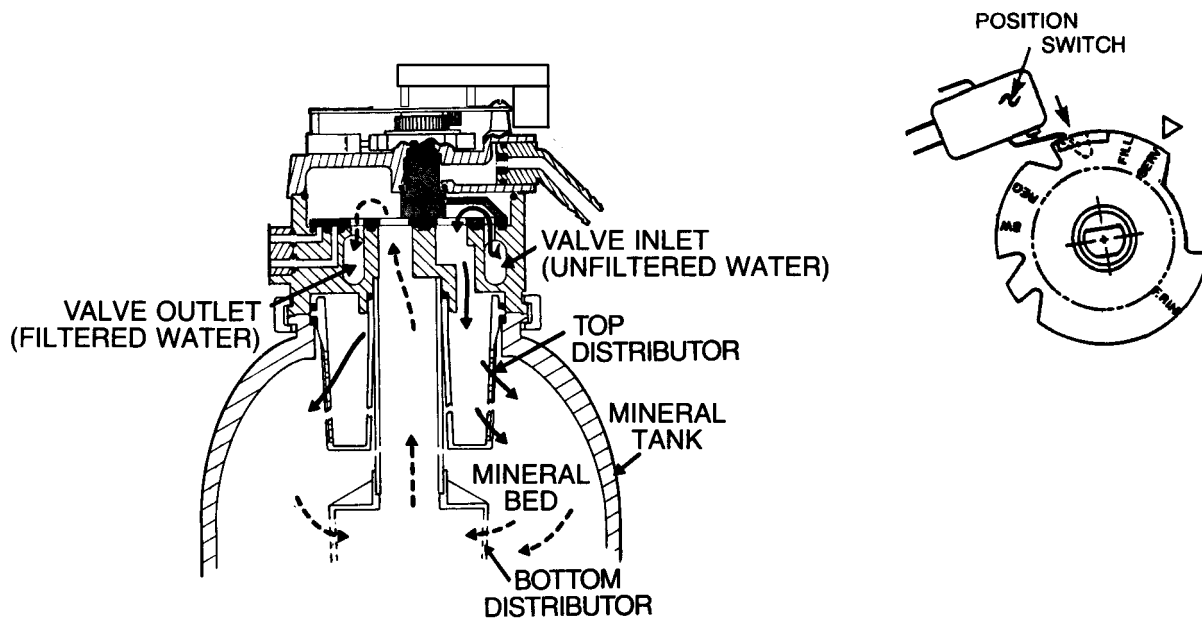

FIGURE 12

BACKWASH CYCLE

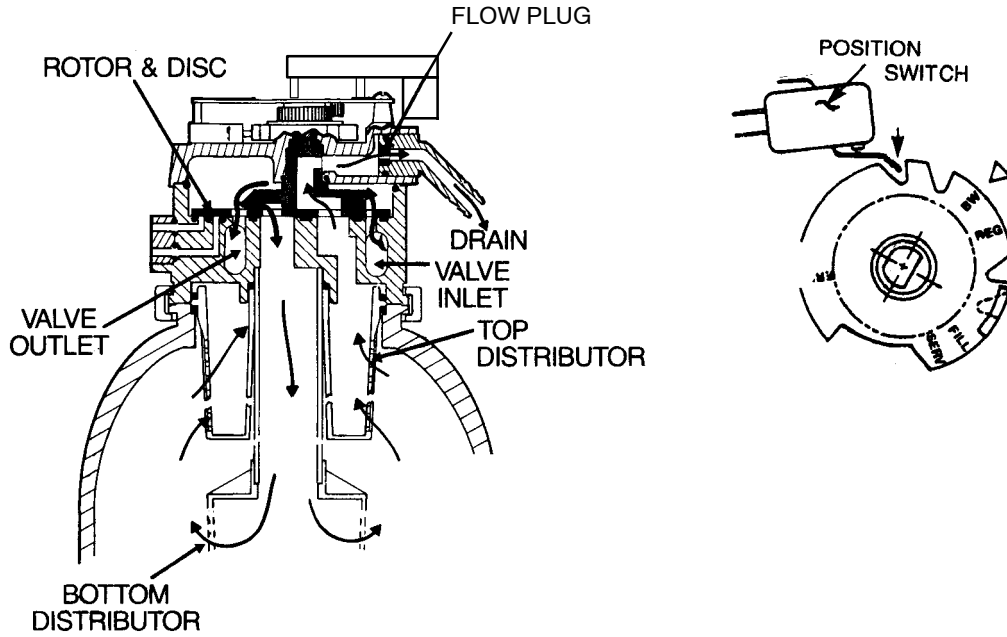
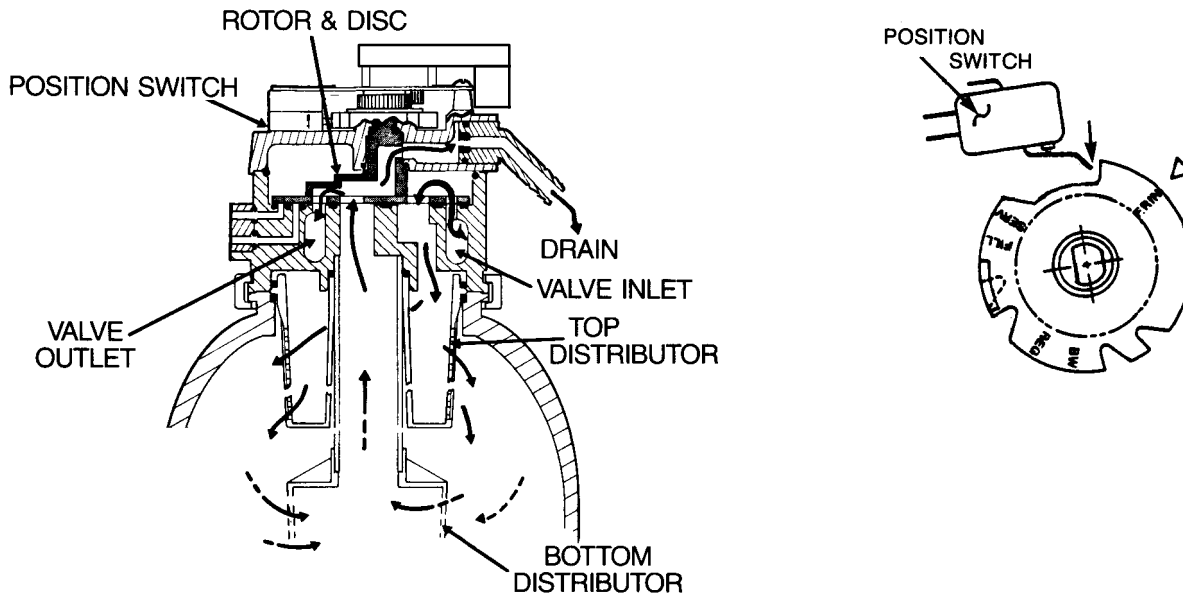

FIGURE 13

FAST RINSE CYCLE



Description of Operation - Air pump activation & solenoid venting system

When service water flows through the filter, it rotates the turbine (located in the valve's outlet port), sending a signal to the controller (PWA). The controller then activates a 24V power supply to the vent solenoid and relay box. When activated, the relay box turns on the 120V power supply to the air pump. The air pump adds a head of air in the filter tank. This supplies oxygen that aerates the water and oxidizes iron, manganese and hydrogen sulfide (generating particles). The vent solenoid is opened during this time, permitting oxygen-depleted air to escape and be continuously replaced in the tank by fresh air. After oxidation, the birm filtration media filters out the particles. During the backwash / rinse cycles, the filter cleans itself. During regenerations the air pump and vent solenoid do not activate. After service water flow stops, the air pump will run for an additional 8 seconds.

Adaptor Troubleshooting Guide

If excess air is in household plumbing, the air vent is most likely plugged with debris.

Close the ball valve. Then disconnect tubing from solenoid inlet, as shown below. Remove the inlet screen, located inside the inlet port of the solenoid. Clean and reinstall the inlet screen.

After vent is cleared, reconnect tubing, open ball valve and check for leaks.

Solenoid Inlet
(remove and clean screen)

WARNING: FILTER TANK CONTAINS AIR. TO RELIEVE PRESSURE, PUT BYPASS VALVE IN BYPASS AND ADVANCE FILTER VALVE TO BACKWASH BEFORE DISASSEMBLY.

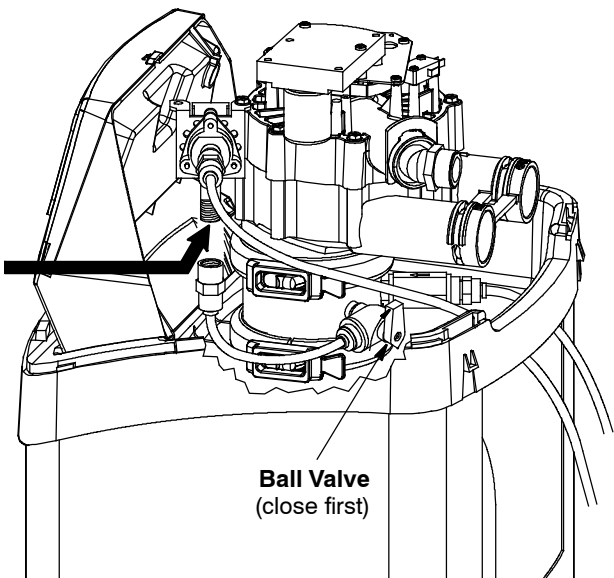

TROUBLESHOOTING

ALWAYS MAKE THESE INITIAL CHECKS FIRST

1. Does the time display show the correct time of day?

...If display is blank, check power source to the filter.

...If time is flashing, power was off for over 6 hours. The filter resumes normal operation but backwashes occur at the wrong time.

2. Plumbing bypass valve(s) must be in SERVICE position (see Figure 7, page 8).

3. The inlet and outlet pipes must connect to the filter inlet and outlet respectively.

4. Is the transformer plugged into a "live" grounded wall outlet, and the power cable fastened securely?

5. The valve drain hose must be free of kinks and sharp bends.

6. If the air pump is not running, check for binding of the turbine, check that the leads of the relay box are connected to the back of the faceplate and there is power to the relay box.

If you do not find the problem after making the initial checks, do the MANUAL ADVANCE DIAGNOSTICS.

**MANUAL INITIATED
ELECTRONICS DIAGNOSTIC**

1. To enter diagnostics, press and hold the SELECT keypad until (000- -) shows in the display.



The letter (P) and dash or dashes indicate position switch operation. The letter shows if the switch is closed and the motor is rotating. A dash shows when the switch is open.

SWITCH DISPLAYS	VALVE CYCLE STATUS
- -	valve in service, backwash or fast rinse position
- P	valve rotating from one position to another

Use the RECHARGE keypad to manually advance the valve into each cycle and check correct switch operation.

While in this diagnostic screen, the following information is available and may be beneficial for various reasons. This information is retained by the computer from the first time electrical power is applied to the face plate.

NOTE: If the face plate is left in a diagnostic display (or a flashing display when setting times or days to recharge), preset time automatically returns if a button is not pressed within 4 minutes.

RESETTING TO FACTORY DEFAULTS

To reset the electronic controller to its factory default for all settings (time, days to recharge, etc.):

1. Press the SELECT keypad and hold it until the display changes twice to show "CODE" and the flashing model code.

...Press the UP keypad to display the number of days this face plate has had electrical power applied.



...Press the DOWN keypad to display the number of recharges initiated by this face plate since the model code number was entered.



2. Press the SELECT keypad and hold for 3 seconds until the model code appears in the display.

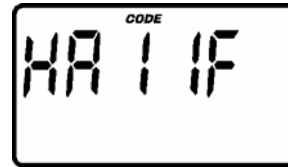

NOTE: For correct filter operation, the model code must be HA I IF.

To reset the code, press the UP or DOWN keypads until the correct model code shows in the display.

3. Press the SELECT keypad to return the present time display. If the code was changed, make ALL the timer settings, page 11 and 12.

2. Press the UP keypad (a few times, if necessary) to display a flashing "SoS".

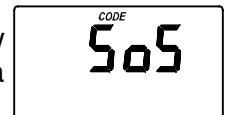

3. Press the SELECT keypad, and the electronic controller will restart.

4. Set the present time, days to recharge, etc., as described on pages 11 & 12.

MANUAL ADVANCE DIAGNOSTICS

Use the following procedures to advance the filter valve through the recharge cycles to check operation.

Remove the top cover to observe cam and switch operation during valve rotation.

DISPLAY MUST SHOW TIME AND DAY

1. Press and hold the RECHARGE keypad for 3 seconds until RECHARGE NOW flashes in the display and the filter moves into the backwash cycle.



...If the motor does not run, check the motor and all wiring connections.

Look for a fast flow of water from the drain hose (see specifications, page 4).

...An obstructed flow indicates a plugged top distributor, backwash flow plug, or drain hose.

NOTE: Be sure household water pressure (well system) is maintained at a minimum of 20 psi. Adjust the pump switch upward, if needed.

2. Press the RECHARGE keypad to move the filter into fast rinse. Again, look for a drain flow rate about the same as backwash.

3. To return the filter to service, press the RECHARGE keypad once.

OTHER SERVICE

UNFILTERED WATER BYPASS (unfiltered water “bleeds” into filtered water supply.

1. Missing or defective o-ring(s) at resin tank to valve connection (see pages 20 and 21).

2. Defective rotor disc, seal or wave washer (see pages 22 and 23).

WATER LEAKS FROM DRAIN HOSE (during service)

1. Defective rotor disc, seal, or wave washer.

2. Defective o-ring on disc shaft.

AUTOMATIC ELECTRONIC DIAGNOSTICS

The face plate has a self diagnostic function for the electrical systems (except input power). The face

plate monitors the electronic components and circuits for correct operation. If a malfunction occurs, an error code appears in the face plate display.

POSSIBLE DEFECT

CODE	MOST LIKELY	LEAST LIKELY
Err 01, Err 03 & Err 04	wiring harness or connection to position switch / switch / valve defect causing high torque / motor inoperative	
Err 05	faceplate	

PROCEDURE FOR REMOVING ERROR CODE FROM FACEPLATE: 1. Unplug transformer----- 2. Correct defect----- 3. Plug in transformer----- 4. Wait for 8 minutes. The error code will return if the defect was not corrected. Press and hold the RECHARGE keypad for 3 seconds as an alternate way to clear an error code.

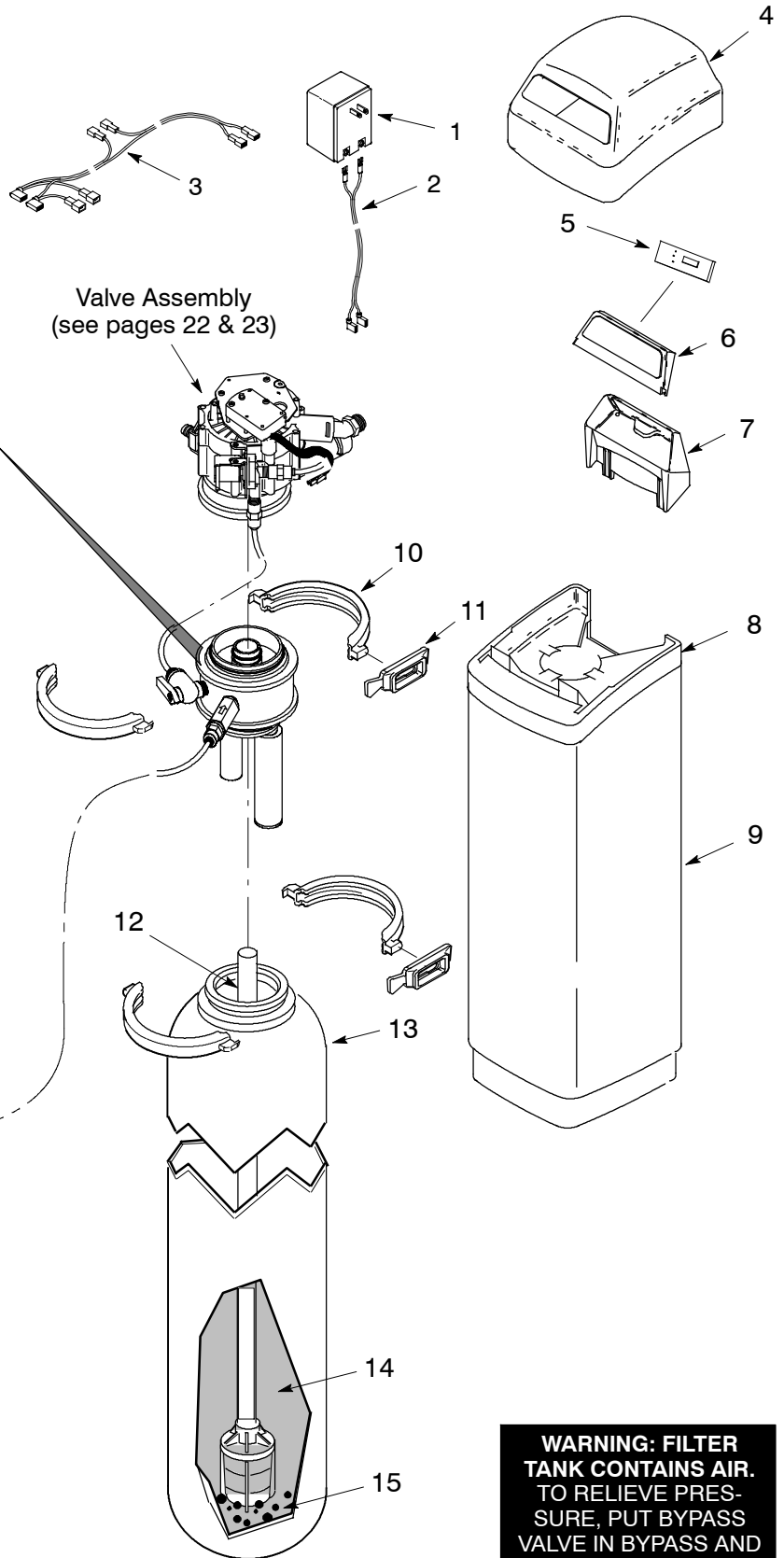
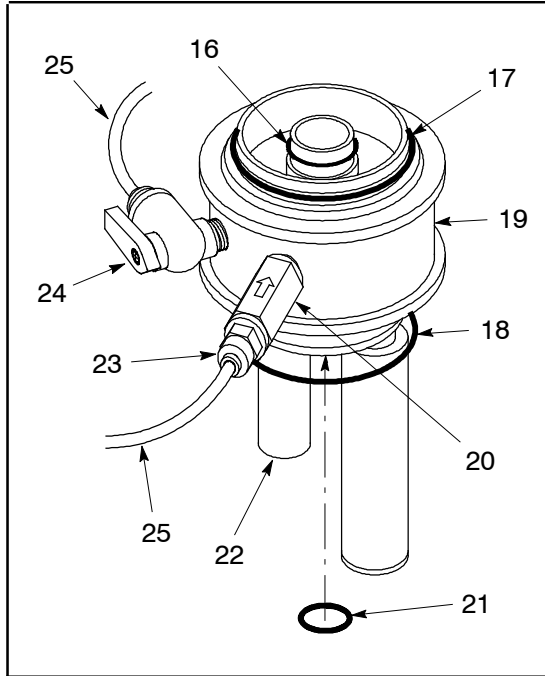

WARNING: FILTER TANK CONTAINS AIR. TO RELIEVE PRESSURE, PUT BYPASS VALVE IN BYPASS AND ADVANCE FILTER VALVE TO BACKWASH BEFORE DISASSEMBLY.

KEY NO.	PART NO.	DESCRIPTION
1	7085297	Transformer, 24V – 40VA
2	7132840	Power Cord
3	7322801	Wire Harness, Solenoid
4	7218670	Top Cover
5	7285813	Repl. PWA
6	7210509	Faceplate (order following decal)
–	7308970	Decal
7	7211173	Faceplate Support
8	7287792	Rim
9	7313218	Shroud
–	7331177	Tank Neck Clamp Kit (includes 2 ea. of Key Nos. 10 & 11)
10	↑	Clamp Section, 4 req.
11	↑	Retainer Clip, 4 req.
12	7105047	Rep'l Distributor, bottom
13	7092202	Resin Tank, 10" dia. x 47"
14	4015000	Birm, Pkd.
15	7124415	Quartz

KEY NO.	PART NO.	DESCRIPTION
–	7112963	Distributor O–ring Kit (includes Key Nos. 16–18)
16	↑	O–ring, 13/16 I.D. x 1–1/16 O.D.
17	↑	O–ring, 2–7/8 I.D. x 3–1/4 O.D.
18	↑	O–ring, 2–3/4 I.D. x 3 O.D.
19	7310278	Adaptor Assembly (includes Key Nos. 20–24)
20	7190628	Check Valve
21	7168312	O–ring, 63/64 I.D. x 1–1/4 O.D.
22	7306813	Nipple
23	7171666	Connector, 1/4 Tube to 1/4 NPT
24	7306839	Ball Valve
25	7161823	Tubing, 1/4" x 20 ft.
26	7322681	Relay Box
27	7288081	Air Pump, 120V (incl. Key No. 28)
28	7171666	Connector, 1/4 Tube to 1/4 NPT (use with Gast Pump)
	7171674	Connector, 1/4 Tube to 1/8 NPT (use with Thomas Pump)
–	7311313	Adaptor Kit (incl. Key Nos. 16–19 & 2 ea. of 10 & 11)

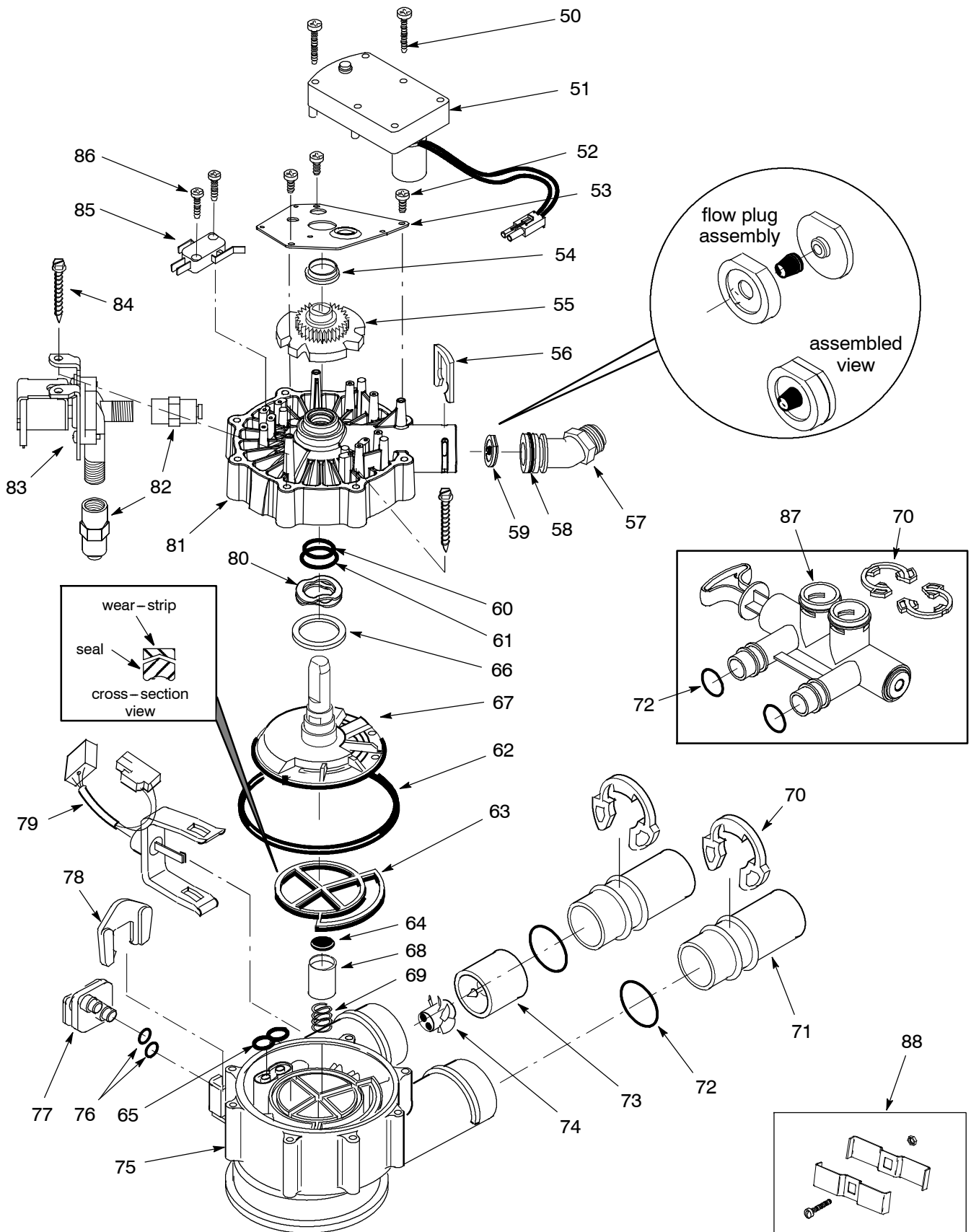

KEY NO.	PART NO.	DESCRIPTION
50	7224087	Screw, #6-20 x 7/8 (2 req.)
51	7286039	Motor (incl. 2 ea. of Key No. 50)
52	0900857	Screw, #6-20 x 3/8 (3 req.)
53	7231393	Motor Plate
54	7171250	Bearing
55	7283489	Cam and Gear
56	7169180	Clip (Drain)
57	7172793	Drain Hose Adaptor
58	7170288	O-ring, 15/16 x 1-3/16
59	7178189	Flow Plug, 5 gpm
-	7185487	Seal Kit (includes Key Nos. 60-65)
60	↑	O-ring, 5/8 x 13/16
61	↑	O-ring, 1-1/8 x 1-1/2
62	↑	O-ring, 4-1/2 x 4-7/8
63	↑	Rotor Seal
64	↑	Seal
65	↑	Seal, Nozzle & Venturi
66	7174313	Bearing, Wave Washer
67	7185500	Rotor & Disc
68	7171187	Plug (Drain Seal)
69	7129889	Spring
70	7089306	Clip (2 req.)

KEY NO.	PART NO.	DESCRIPTION
71	7077642	Copper Tube, 1" (2 req.)
72	7311127	O-ring, 1-1/16 x 1-5/16 (4 req.)
-	7290931	Turbine & Support Assembly (includes 1 ea. of Key Nos. 73, 74 & 2 ea. of Key No. 72)
73	↑	Turbine Support & Shaft
74	↑	Turbine
75	7171145	Valve Body
76	7170319	O-ring, 1/4 x 3/8 (2 req.)
77	7100940	Plug
78	7081201	Retainer
79	7309811	Wire Harness & Sensor Housing
80	7175199	Wave Washer
81	7171161	Valve Cover
82	7306821	Connector, 1/4 QC to 1/4 NPT (2 req.)
83	7322699	Solenoid
84	7172997	Screw, #10 x 2-5/8 (8 req.)
85	7305150	Switch (2 req.)
86	7140738	Screw, #4-24 x 3/4 (4 req.)
87	7214383	Bypass Valve (includes 2 ea. of Key Nos. 70 & 72)
88	7248706	Ground Clamp Kit

**EcoWater Systems LLC
Advantage Warranty
Series ETF AllF Water System**

Congratulations! You have just purchased the highest quality water conditioning product on the market. To register your warranty, complete the enclosed Warranty Registration Card and mail it within 30 days of purchase.

To whom is this warranty extended?

EcoWater Systems LLC warrants its products to the original owner and guarantees that the products will be free from defects in materials and workmanship from the original date of installation.

How does my warranty work?

If, during the respective warranty period, a part proves, after inspection by EcoWater, to be defective, EcoWater will, at its sole option repair or replace that part at no charge, other than normal shipping and installation charges.

What is covered by the warranty?

EcoWater systems LLC guarantees that,

for the LIFETIME of the original owner, the MINERAL TANK will not rust, corrode, leak, burst, or in any other manner fail to perform their proper functions and that,

for a period of FIVE (5) YEARS after installation, the VALVE BODY will be free of defects in materials and workmanship and will perform its proper function and that,

for a period of THREE (3) YEARS after installation, the ELECTRONIC FACEPLATE will be free of defects in materials and workmanship and will perform its normal functions and that,

for a period of ONE (1) YEAR after installation, ALL OTHER PARTS will be free of defects in materials and workmanship and will perform their normal functions.

How do I obtain local service?

Should you need service, your local, independent EcoWater Dealer is only a phone call away.

PHONE: _____

If I need a part replaced after the factory warranty expires, is that part warranted?

Yes, EcoWater Systems LLC warrants FACTORY REPAIRS as well as all replacement parts for a period of 90 DAYS.

Are any additional warranties available?

We are pleased to say, YES! EcoWater Systems LLC offers an EXTENDED, PARTS ONLY WARRANTY for the ELECTRONICS portion of your product. This warranty is called the "Perfect Ten" and extends the three year warranty on the electronic FACEPLATE, WIRING HARNESS, DRIVE MOTOR, TRANSFORMER, POWER CORD, SENSOR HOUSING, and MICRO SWITCHES to a total of TEN YEARS from the date of original installation. Should your local dealer not offer this warranty, you may contact the factory for additional information.*

General Provisions

The above warranties are effective provided the water conditioner is operated at water pressures not exceeding 125 psi, and at water temperatures not exceeding 120°F; provided further that the water conditioner is not subject to abuse, misuse, alteration, neglect, freezing, accident or negligence; and provided further that the water conditioner is not damaged as the result of any unusual force of nature such as, but not limited to, flood, hurricane, tornado or earthquake. EcoWater Systems LLC, is excused if failure to perform its warranty obligations is the result of strikes, government regulation, materials shortages, or other circumstances beyond its control.

To obtain warranty service, notice must be given, within thirty (30) days of the discovery of the defect, to your local EcoWater Systems dealer.

*THERE ARE NO WARRANTIES ON THE WATER CONDITIONER BEYOND THOSE SPECIFICALLY DESCRIBED ABOVE. ALL IMPLIED WARRANTIES, INCLUDING ANY IMPLIED WARRANTY OF MERCHANTABILITY OR OF FITNESS FOR A PARTICULAR PURPOSE, ARE DISCLAIMED TO THE EXTENT THEY MIGHT EXTEND BEYOND THE ABOVE PERIODS. THE SOLE OBLIGATION OF ECOWATER SYSTEMS LLC UNDER THESE WARRANTIES IS TO REPLACE OR REPAIR THE COMPONENT OR PART WHICH PROVES TO BE DEFECTIVE WITHIN THE SPECIFIED TIME PERIOD, AND ECOWATER IS NOT LIABLE FOR CONSEQUENTIAL OR INCIDENTAL DAMAGES. NO ECOWATER DEALER, AGENT, REPRESENTATIVE, OR OTHER PERSON IS AUTHORIZED TO EXTEND OR EXPAND THE WARRANTIES EXPRESSLY DESCRIBED ABOVE.

Some states do not allow limitations on how long an implied warranty lasts or exclusions or limitations of incidental or consequential damage, so the limitations and exclusions in this warranty may not apply to you. This warranty gives you specific legal rights, and you may have other rights which vary from state to state. This warranty applies to consumer-owned installations only.