

**V**

# ROLLERI ROLLA-V ONYX DIES

Content Explanation	202 - 203
Model 1	204
Model 2	205
Model 2.5	205
Model 3	206
Model 4	206
Adjustable Dies	207
Hemming and Joggle Tools	207

### Compatibility

- **RVP Dies (Models 1, 2, 3)** are compatible with press brake machines (60 mm / 2.36 in die holder) from: ACL, Accurpress, AM Machinery, Amada, Atlantic, Adira, Baykal, BL, Boschert, Boutillon, Bystronic-Beyeler Euro-B, Coastone, Colgar, Dener, Deratech, Durmazlar, Ermaksan, Farina, Gade, Gasparini, Gizelis, Haco, Hindustan, Iturraspe, Jfy, LFK, MVD, Newton, Prima Power, Promecam, Rico, Salvagnini, Schiavi, SMD, Sorg, Somo, Vicla, Vimercati, Warcom, Yangli, Yawei, Ysd, etc.
- **RVS Dies (Models 1, 2, 3)** are compatible with press brake machines (14 mm / 0.55 in tang) from: Amada Single V style
- **RVT Dies (Models 1, 2, 3)** are compatible with press brake machines (12.7 mm / 0.50 in / 13 mm / 0.51 in tang) from: Bystronic, Hämmerle, Beyeler, Edwards, Safan, SMD, Trumpf
- **RVT90 Dies (Models 1, 2, 3)** are compatible with press brakes machines (12.7 mm / 0.50 in tang) from: LVD
- **RVM Dies (Models 2.5, 3, 4)** are compatible with all press brake machines (various die holders)
- all dies can be mounted in other press brakes by using adapters or customized die holders.

### Our Advantages – Your Convenience

- no corrosion
- fast and easy tool change
- new design
- longer operational life
- high precision
- interchangeability guaranteed
- reduction of bending marks on the sheet metal
- small flanges bent without marks
- No metal residue left on tools during bending of galvanized sheet metal
- ideal for profiles with oblique sides

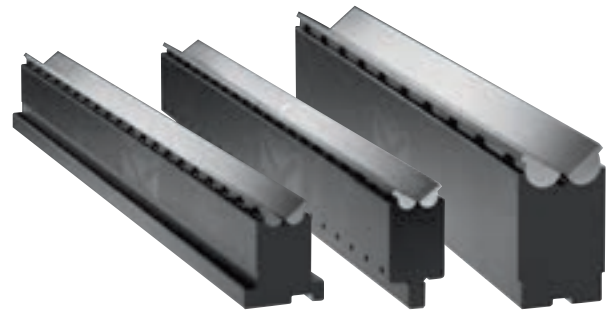

### Material

Raw material is provided by qualified suppliers and chemical composition corresponds to international standards. Therefore, raw material yield and tensile strength are guaranteed.

	Model	Material Type	Hardness of the material and the tool body	Hardness of the operating surfaces after induction hardening
Body	1 / 2 / 2.5 / 3 / 4	42CrMo4	1100-1200 N/mm <sup>2</sup>	55 HRc
Inserts	1 / 2 / 2.5	Toolox 44	1450 N/mm <sup>2</sup>	through hardened 44 HRc
Inserts	3 / 4	Toolox 33	1100 N/mm <sup>2</sup>	55 HRc

- Specifications for the maximum press force kN/m are indicated as such, **1 t = 10 kN**.

	Equivalent V size mm (in)	max. tool load (kN/m)	Material Thickness mm (in)	min. bending angle	needed press force (kN)	min. outside flange mm (in)	max. outside radius mm (in)
Model 1 Max. recommended thickness =1.5 mm (0.06 in) (2.0 mm / 0.08 in possible)	8 (0.31)	1000	0.70 (0.03)	40°	50	3.0 (0.12)	3.0 (0.12)
		1000	1.10 (0.04)	35°	130	3.9 (0.15)	2.6 (0.10)
		1000	1.50 (0.06)	35°	270	4.2 (0.17)	2.2 (0.09)
Model 2 Max. recommended thickness =3.0 mm (0.12 in) (4.0 mm / 0.15 in possible)	15 (0.59)	1500	2.00 (0.08)	59°	210	8.5 (0.33)	6.0 (0.24)
		1500	3.00 (0.12)	47°	550	9.3 (0.37)	5.0 (0.20)
		1500	3.20 (0.13)	47°	650	9.3 (0.37)	4.8 (0.19)
Model 2.5 Max. recommended thickness =5.0 mm (0.20 in) (6.35 mm / 0.24 in possible)	28 (1.10)	2500	2.00 (0.08)	46°	100	18.6 (0.73)	13.2 (0.52)
		2500	4.00 (0.16)	46°	470	18.6 (0.73)	12.0 (0.47)
		2500	6.00 (0.24)	55°	1270	18.6 (0.73)	9.8 (0.39)
Model 3 Max. recommended thickness =6.3 mm (0.25 in) (8.0 mm / 0.31 in possible)	38 (1.50)	2500	2.00 (0.08)	68°	70	22.5 (0.89)	13.9 (0.55)
		2500	4.00 (0.16)	47°	340	22.5 (0.89)	11.9 (0.47)
		2500	6.00 (0.24)	50°	900	22.5 (0.89)	9.9 (0.39)
Model 4 Max. recommended thickness =16.0 mm (0.63 in)	85 (3.35)	3000	6.00 (0.24)	78°	260	56.6 (2.23)	36.4 (1.43)
		3000	8.00 (0.31)	76°	500	56.6 (2.23)	36.4 (1.43)
		3000	12.00 (0.47)	73°	1290	56.6 (2.23)	36.4 (1.43)

### ■ Tool lengths and sectioning

#### Standard



Segmented tools are delivered in complete sets.  
More lengths and sectionings are possible upon request.

**Model 1, 440 mm (17.32 in) segmented**  
(7 segments)

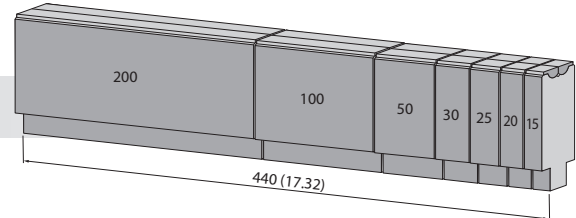

**Model 2, 450 mm (17.72 in) segmented**  
(7 segments)

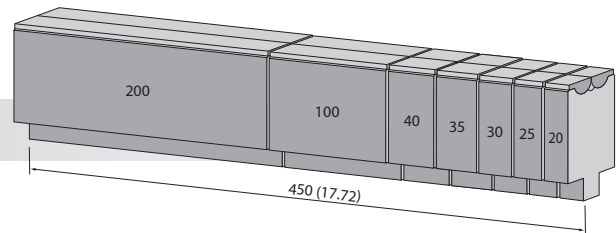

**Model 2.5, 470 mm (18.50 in) segmented**  
(6 segments)

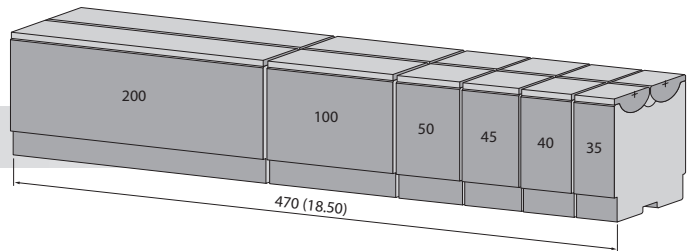

**Model 3, 455 mm (17.91 in) segmented**  
(5 segments)

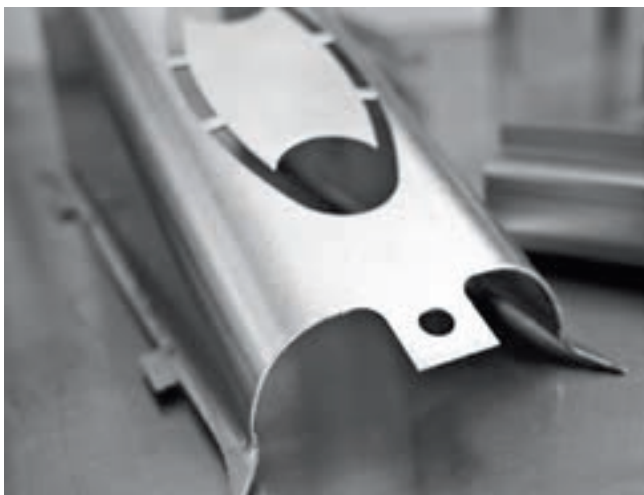
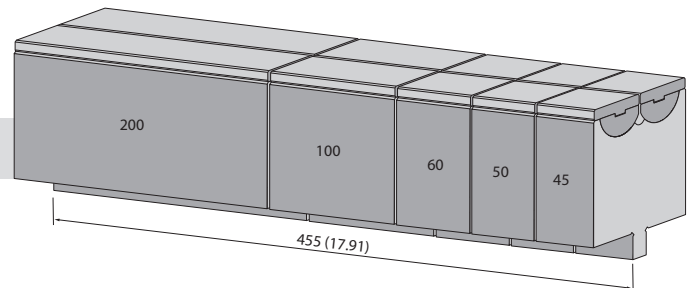

8

### RVP60-1

1000 kN/m max.

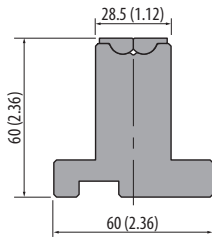

500 mm	16.68 in	6.9 kg
440 mm segmented	17.32 in segmented	6.1 kg

42Cr: 1100-1200 N/mm<sup>2</sup>



### RVS80-1

1000 kN/m max.

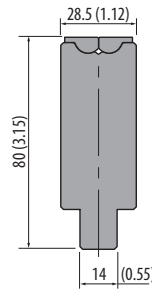

500 mm	16.68 in	6.3 kg
440 mm segmented	17.32 in segmented	5.8 kg

42Cr: 1100-1200 N/mm<sup>2</sup>



### RVT55-1

1000 kN/m max.

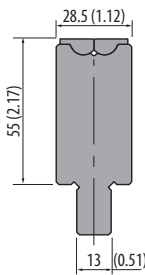

500 mm	16.68 in	5.5 kg
440 mm segmented	17.32 in segmented	5.0 kg

42Cr: 1100-1200 N/mm<sup>2</sup>



### RVT90-1

1000 kN/m max.

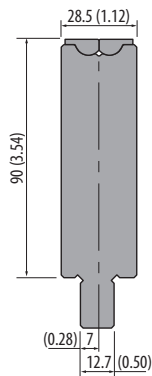

500 mm	16.68 in	8.5 kg
440 mm segmented	17.32 in segmented	7.8 kg

42Cr: 1100-1200 N/mm<sup>2</sup>



### RVT100-1

1000 kN/m max.

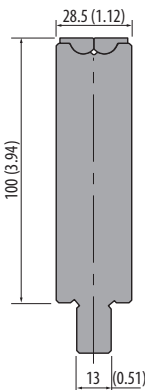

500 mm	16.68 in	9.4 kg
440 mm segmented	17.32 in segmented	8.6 kg

42Cr: 1100-1200 N/mm<sup>2</sup>



### Rolleri Videos



Use and application of Rolla-V dies

[www.rolleritools.com/videos/rolla-v](http://www.rolleritools.com/videos/rolla-v)

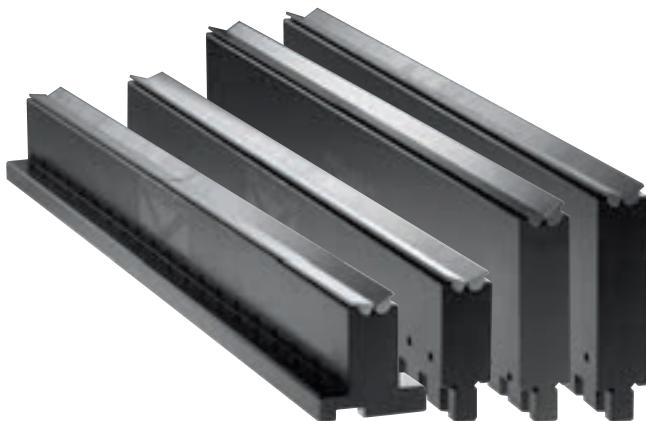

### RVP65-2

1500 kN/m max.

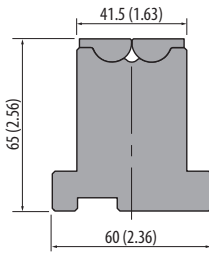

500 mm	16.68 in	7.9 kg
450 mm segmented	17.72 in segmented	7.4 kg

42Cr: 1100-1200 N/mm<sup>2</sup>



### RVS80-2

1500 kN/m max.

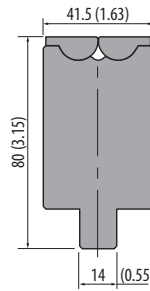

500 mm	16.68 in	8.3 kg
450 mm segmented	17.72 in segmented	7.8 kg

42Cr: 1100-1200 N/mm<sup>2</sup>



### RVT60-2

1500 kN/m max.

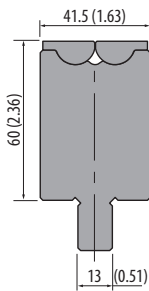

500 mm	16.68 in	7.9 kg
450 mm segmented	17.72 in segmented	7.4 kg

42Cr: 1100-1200 N/mm<sup>2</sup>



### RVT90-2

1500 kN/m max.

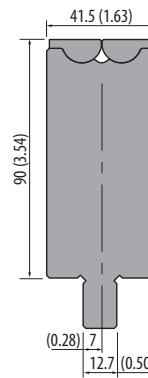

500 mm	16.68 in	11.3 kg
450 mm segmented	17.72 in segmented	10.6 kg

42Cr: 1100-1200 N/mm<sup>2</sup>



### RVT100-2

1500 kN/m max.

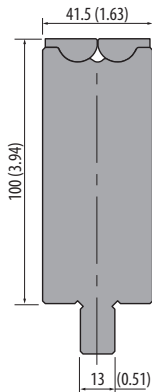

500 mm	16.68 in	12.4 kg
450 mm segmented	17.72 in segmented	11.7 kg

42Cr: 1100-1200 N/mm<sup>2</sup>



## Model 2.5

### RVM2.5

2000 kN/m max.

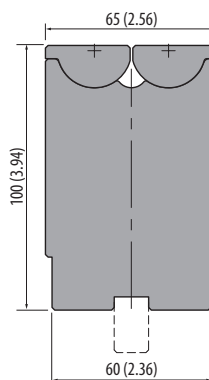

without tang		
500 mm	16.68 in	22.0 kg
470 mm segmented	18.50 in segmented	21.0 kg
with tang 0.51x0.79 in		
500 mm	16.68 in	23.5 kg
470 mm segmented	18.50 in segmented	22.4 kg
with tang 0.5x0.75 in		
500 mm	16.68 in	23.5 kg
470 mm segmented	18.50 in segmented	22.4 kg

42Cr: 1100-1200 N/mm<sup>2</sup>

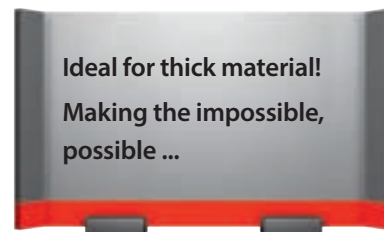

Article on stock



Please ask for delivery time!

1 kg = 2.20 Pounds (lb) = 35.27 Ounces (oz)  
100 mm = 3.94 Inch (in) = 0.33 Feet (ft)



Articles on stock – Please note that delivery time depends on your location.

### RVP100-3

2500 kN/m max.

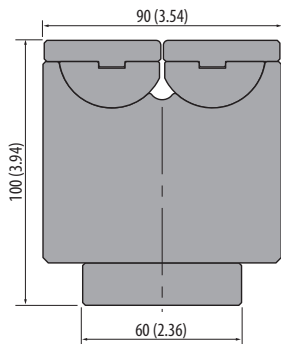

500 mm	16.68 in	28.8 kg
455 mm segmented	17.91 in segmented	26.2 kg

42Cr: 1100-1200 N/mm<sup>2</sup>



### RVM70-3

2500 kN/m max.

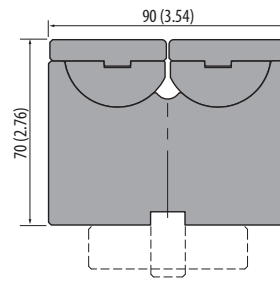

without tang		
500 mm	16.68 in	20.6 kg
455 mm segmented	17.91 in segmented	18.7 kg

with base 2.36 in		
500 mm	16.68 in	23.5 kg
455 mm segmented	17.91 in segmented	23.0 kg

with tang 0.51 in		
500 mm	16.68 in	22.1 kg
455 mm segmented	17.91 in segmented	20.1 kg

with offset tang 0.5 in		
500 mm	16.68 in	22.1 kg
455 mm segmented	17.91 in segmented	20.1 kg

42Cr: 1100-1200 N/mm<sup>2</sup>



### RVT100-3

2500 kN/m max.

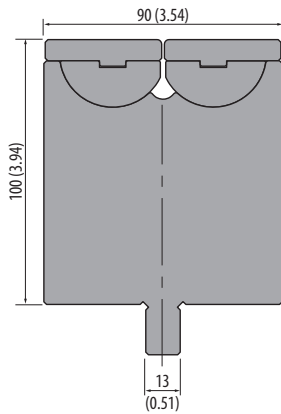

500 mm	16.68 in	30.9 kg
455 mm segmented	17.91 in segmented	28.5 kg

42Cr: 1100-1200 N/mm<sup>2</sup>

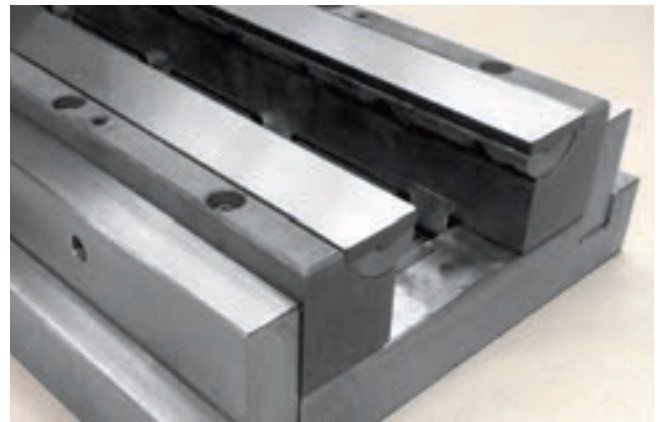

## Model 4

### Our Advantages – Your Convenience

The **model 4 tools** and the **adjustable dies** are suitable for thick sheet metal and large-radius bends. Material specifications vary greatly, therefore no specific data can be given.

- minimum flanges depend on the bending angle
- distortion of holes near the bending line is substantially decreased, although it depends on the type of the sheet metal
- large-radius bends are influenced by sheet metal springback, type of material and flange length

For advice please contact us!

### RVM90-4

3000 kN/m max.

		without tang		with tang 0.51 in	
500 mm	16.68 in	56.6 kg	500 mm	16.68 in	58.1 kg
200 mm	7.87 in	22.7 kg	200 mm	7.87 in	23.3 kg

		with base 2.36 in		with offset tang 0.5 in	
500 mm	16.68 in	61.3 kg	500 mm	16.68 in	58.1 kg
200 mm	7.87 in	24.6 kg	200 mm	7.87 in	23.3 kg

42Cr: 1100-1200 N/mm<sup>2</sup>

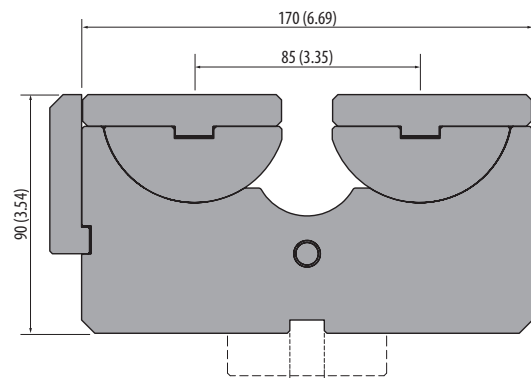

### Our advantages – Your Convenience

- bending up to 30 mm thick sheet metal
- hardened inserts
- no traditional bending marks
- adjustable openings  
 RVPV3 = 39-94 mm (1.54-3.70 in)  
 RVHD3 = 39-118 mm (1.54-4.65 in)  
 RVHD4 = 70-220 mm (2.76-8.66 in)
- bending of laser-cut sheet metal without damaging the tool
- exact inner radius

### RVPV3

2500 kN/m max.

42Cr: 1100-1200 N/mm<sup>2</sup>



500 mm	16.68 in	50.0 kg
200 mm	7.87 in	20.0 kg

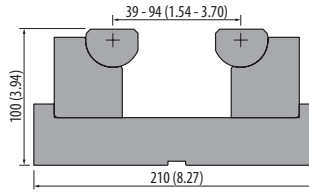

### RVHD3

3500 kN/m max.

42Cr: 1100-1200 N/mm<sup>2</sup>



500 mm	16.68 in	98.0 kg
200 mm	7.87 in	38.1 kg

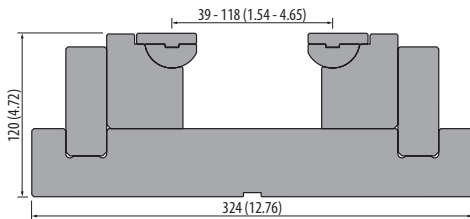

### RVHD4

3500 kN/m max.

42Cr: 1100-1200 N/mm<sup>2</sup>



500 mm	16.68 in	200.0 kg
200 mm	7.87 in	80.0 kg

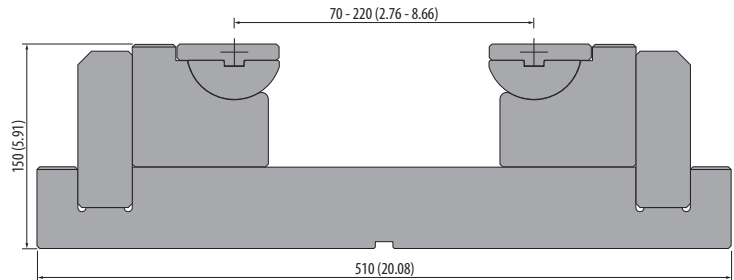

• V-Bending • flat inserts	• Radius-Bending • flat inserts	• Conical Bending • flat inserts	• Radius-Overbending • concave inserts	• U-Bending • V-inserts

### Hemming and Z-Tools

#### Hemming Tool

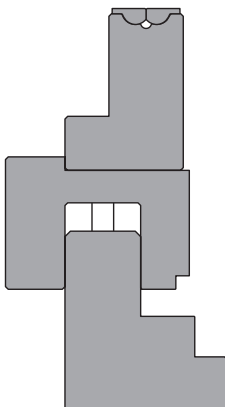

per piece | Price upon request

Production according to your specifications

42Cr: 1100-1200 N/mm<sup>2</sup>



#### Joggle Tool

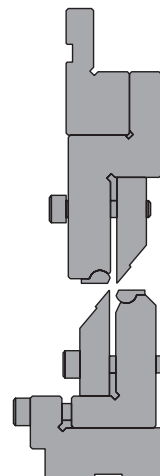

per piece | Price upon request

Production according to your specifications

42Cr: 1100-1200 N/mm<sup>2</sup>

