

70's Glam Meets Cowgirls

Objective



MaKara Blake

Styling

Diana Ross/Cher

Very feminine silhouettes

Fur jacket?

Hair down. Little natural makeup. Ill probably add color and gloss to you as we go.

Tone

Confident in where I am from

How is that achieved?

Embracing the yeehaw and being comfortable with it

Yeehaw props

Mood

Better than you

How it that achieved

Comfortable with the camera, comfortable with yourself and in the clothes

Setting

Dimensional seamless

How is that achieved?

Use lights to add depth and different tones in the background

Final Set-Up

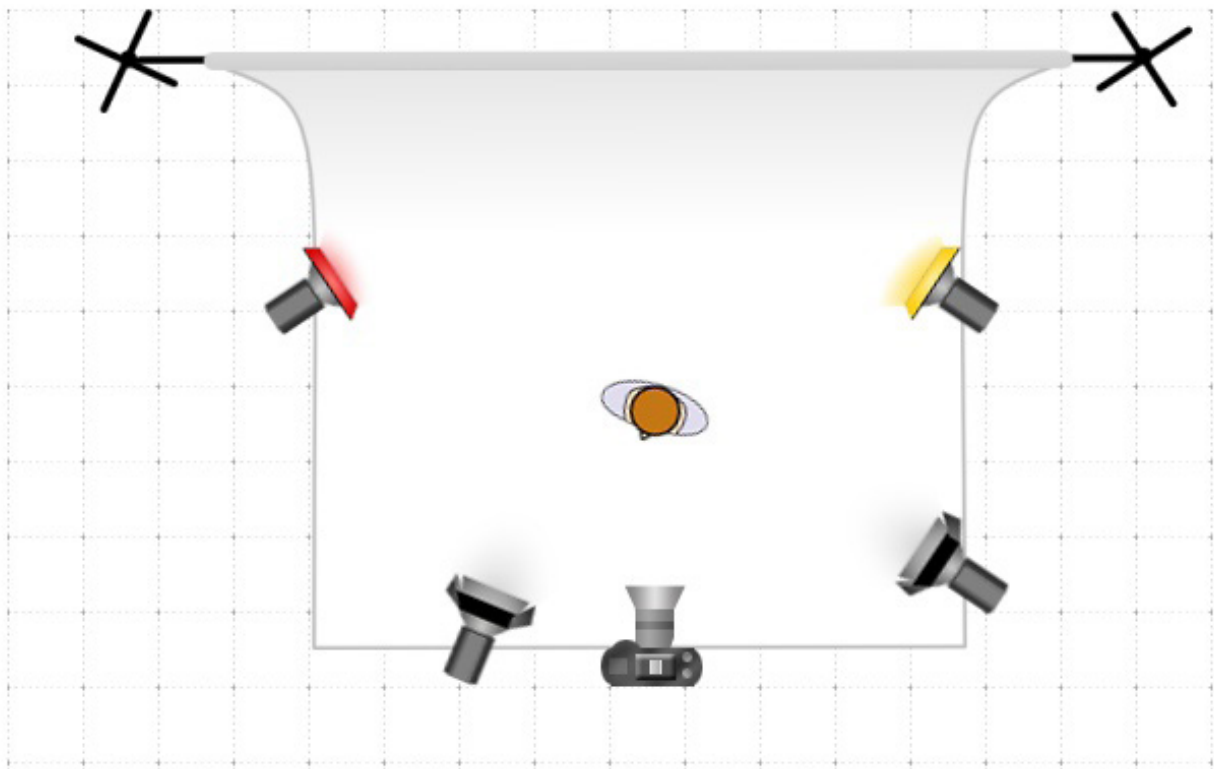

MaKara Blake

Photographer.....MaKara Blake
Art Director.....MaKara Blake
Producer.....MaKara Blake
Lighting.....MaKara Blake
Model.....Deanna Cepena