

# BURTERMINATOR™ FLOAT MANAGEMENT CONTROL SIMPLEX MODEL 1CH-01B MANUAL



<i>AUTHOR</i>	<i>SIMPLEX MANUAL</i>	<i>REV</i>	<i>RELEASED</i>
Tracy Burt	Wiring process and diagram.	3	08/25/2025



## Table of Contents

<b>1. PURPOSE</b> .....	<b>3</b>
<b>2. SCOPE</b> .....	<b>3</b>
<b>3. DEFINITIONS</b> .....	<b>3</b>
<b>4. SAFETY</b> .....	<b>3</b>
<b>5. REQUIRED TOOLS</b> .....	<b>4</b>
<b>6. REQUIRED PARTS</b> .....	<b>4</b>
<b>7. INSTALLATION PROCEDURES</b> .....	<b>4</b>
<b>7.1 Unpackaging</b> .....	<b>4</b>
<b>7.2 Location and Mounting</b> .....	<b>7</b>
<b>7.3 Installation of Wiring</b> .....	<b>9</b>
<b>7.4 Calibration of FMC</b> .....	<b>10</b>
<b>8. APPLICABLE REFERENCES</b> .....	<b>13</b>

## 1. PURPOSE

This manual describes the installation and operation of the IUS BurTerminator™ Float Management Control Model 1CH-01B for Grinder Pumps.



---

*The IUS BurTerminator™ Float Management Control Model 1CH-01B will only work on Grinder Pumps. It will not work on Centrifugal Pumps.*

---

## 2. SCOPE

This manual provides an outline of the procedures used to install and operate the IUS BurTerminator™ Float Management Control Model 1CH-01B for Grinder Pumps. This procedure, in conjunction with a Job Safety Analysis (JSA), provides the minimum standards for safe operations. Deviation from the procedure requires the approval of IUS. Careful consideration of safety requirements and operational needs is an essential part of all job preparations and needs to include all field personnel present as well as Management.



---

*Opening the BurTerminator™ Float Management Control Panel will void the warranty.*

---

## 3. DEFINITIONS

- N/A

## 4. SAFETY



---

**Read ALL instructions prior to installation! Failure to follow appropriate safety measures may lead to serious injury or death! In addition to any instructions contained in this document, follow any safety protocol(s) established by your company and local/federal regulations.**

---



---

**Power being run into utility panels is sufficient to cause serious injury or death. Use Lock-Out Tag-Out protocol when applicable.**

---



---

**Power being run into utility panels is sufficient to cause serious injury or death. When it is necessary to work on equipment that is powered up, take all necessary and prudent safety precautions. Always assume that circuits are live until proven otherwise.**

---



---

*The BurTerminator™ Float Management Control must be installed by a qualified, licensed electrician.*

---

## 5. REQUIRED TOOLS

1. Flathead Screwdriver
2. Phillips Head Screwdriver
3. Impact or Standard Drill
4. Bits matching the Self-Tapping Screws
5. Precision 5/64" Flat Head Screwdriver
6. Digital Multimeter
7. AC Clamp Meter

## 6. REQUIRED PARTS

1. BurTerminator™ Float Management Control Model 1CH-01B.
2. 2 Amp Fuse (2A, 3AG, 250V, Fast Acting, Round Glass, 0.25" x 1.25"). (Included)
3. Two wire caps rated for two 12 AWG wires. (Not included)
4. Four #10 x 1/2" Self-Tapping Screws or Industrial Velcro. (Not included)

## 7. INSTALLATION PROCEDURES

### 7.1 Unpackaging



---

**Read ALL instructions prior to installation! Failure to follow appropriate safety measures may lead to serious injury or death! In addition to any instructions contained in this document, follow any safety protocol(s) established by your company and local/federal regulations.**

---



---

**Power being run into utility panels is sufficient to cause serious injury or death. Use Lock-Out Tag-Out protocol when applicable.**

---



---

**Power being run into utility panels is sufficient to cause serious injury or death. When it is necessary to work on equipment that is powered up, take all necessary and prudent safety precautions. Always assume that circuits are live until proven otherwise.**

---



---

*The BurTerminator™ Float Management Control must be installed by a qualified, licensed electrician.*

---



*Opening the Float Management Control Panel will void the warranty.*



*The BurTerminator™ Float Management Control Model 1CH-01B will only work on Grinder Pumps. It will not work on Centrifugal Pumps.*

1. Conduct a site inspection concentrating on hazard identification. Take note of hazards where the procedure will take place.
2. Open the box.
3. Remove the Float Management Control panel from the shipping container.
4. Remove any packing material.



5. Remove the zip ties and uncoil the wires.
6. Locate and identify the labels on each wire.
  - a. There will be two black 12 AWG Motor Wires.
  - b. There will be one grey Control Off Float Wire with one red and one black 18-2 AWG Wire.
  - c. There will be one black Control Wire with one black, one white and one green 18-3 AWG Wire.

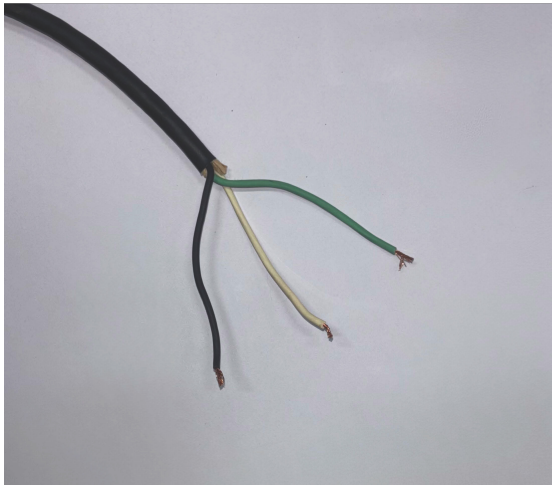

7. Note the Fuse Holder on the top right of the panel on the Model 1CH-01B. The Fuse Holder Fuse Holder takes a 2 Amp Fuse (2A, 3AG, 250V, Fast Acting, Round Glass, 0.25" x 1.25"). Open the Fuse Holder and ensure that the correct Fuse is installed. Close the Fuse Holder.

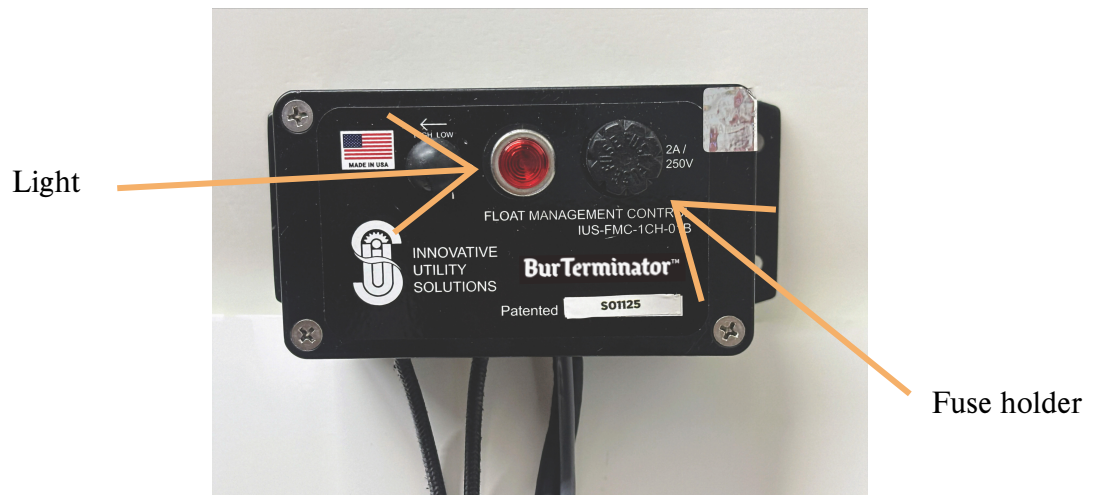

8. There is one red light on the face of the Panel on Model 1CH-01B. The indicator light is on when the FMC is actively overriding the Float Switch to keep the Grinder Pump operating.

Silicone button

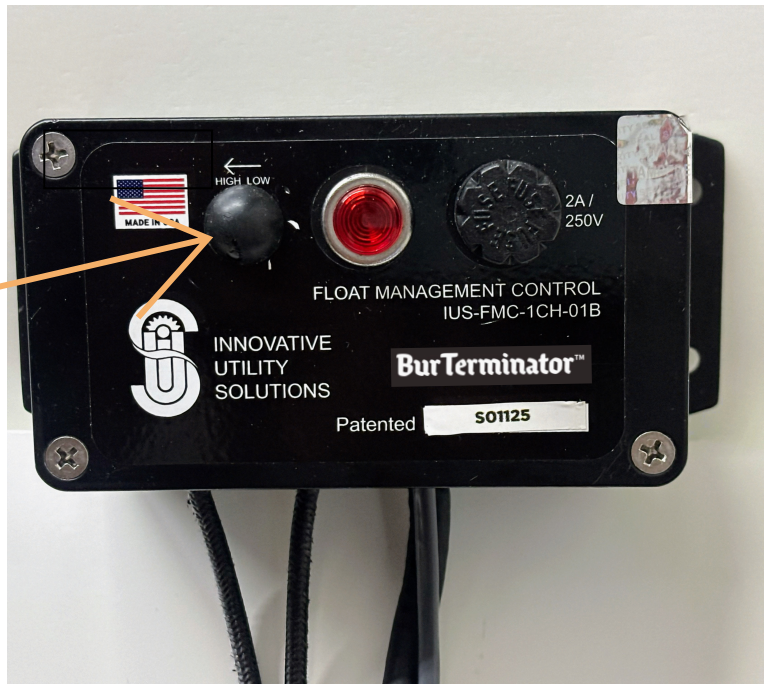

9. There is one silicone button on the left hand side. Printed above the button are the words “High” and “Low” with an arrow pointing to the left between them. Underneath the silicone button is the High-Low Adjustment Screw. The silicone button will be temporarily removed to allow access to the High-Low Adjustment Screw later in the procedures. Always ensure that it is replaced to keep the unit sealed.

## 7.2 Location and Mounting

1. Conduct a site inspection concentrating on hazard identification. Take note of hazards around the control panel where the procedure will take place.



**Power being run into utility panels is sufficient to cause serious injury or death. Use Lock-Out Tag-Out protocol when applicable.**



**Power being run into utility panels is sufficient to cause serious injury or death. When it is necessary to work on equipment that is powered up, take all necessary and prudent safety precautions. Always assume that circuits are live until proven otherwise.**

2. Open the Motor Control Panel.
3. Inside the control panel locate an area to mount the FMC Panel. It can be attached to the back wall. Ensure that all the leads will reach the locations needed.

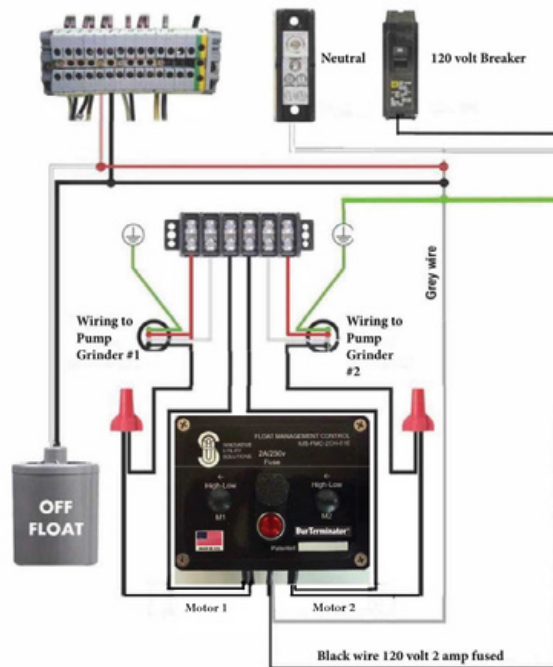

4. Use self-tapping screws and the holes on the flange on the FMC Panel to mount the FMC Panel to the back wall or use Industrial Velcro to attach to wall or sides.

### 7.3 Installation of Wiring



**Turn off power before proceeding. Power being run into utility panels is sufficient to cause serious injury or death.**



**Power being run into utility panels is sufficient to cause serious injury or death. Use Lock-Out Tag-Out protocol when applicable.**

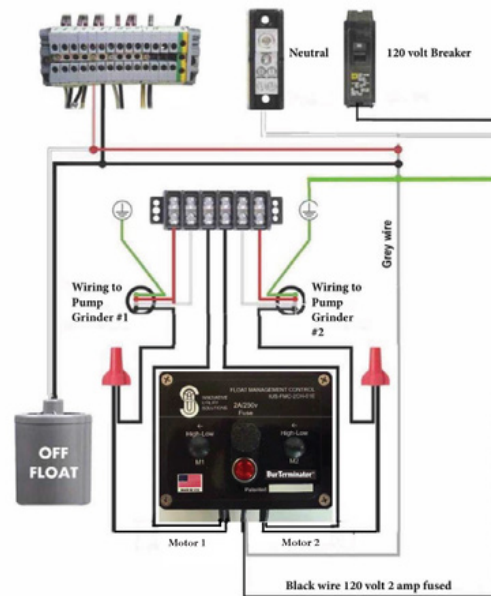

1. Turn off power to the Grinder Motor.
2. Check and verify that power has been turned off before proceeding. Conduct Lock Out/Tag Out as applicable.
3. Remove the black Motor Lead from M1 or M2 depending if installing Duplex or Simplex model from the Control Panel Terminal Block and attach it to the FMC Motor black Lead 12 AWG Wire with a wire nut.
4. Attach the remaining FMC Motor black Lead 12 AWG Wire to the Control panel Terminal Block in the spot where the black Motor Lead was taken from.
5. Take the grey Off Float (18-2) Wire and locate a clean path to install wire neatly in the Control Panel reaching the final location for each wire. These two wires will be placed in tandem with the existing Off Float Wires without removing the original Off Float Wires.

6. Take the black Control Wire (18-3) and locate the black Lead and place it under a 120 vac power supply in the panel which is protected by a 2 amp fuse in the FMC.
7. Locate the white Wire in the black Control Wire (18-3) and place on a neutral bar.
8. Locate the green Wire in the black Control Wire (18-3) and place on a ground bar.



*Verify all wiring is correct and properly connected.*

#### 7.4 Calibration of FMC



**Power being run into utility panels is sufficient to cause serious injury or death. When it is necessary to work on equipment that is powered up, take all necessary and prudent safety precautions. Always assume that circuits are live until proven otherwise.**



*Ensure the floats for the motors give the motor an adequate amount of water around the motor to keep it cool while running. It is recommended that the final normal operating level of the water is to be no more than 2" below the top of the motor.*

1. Attach the AC Clamp Meter to the corresponding M1 or M2 Motor Lead 12 AWG Black Wire.

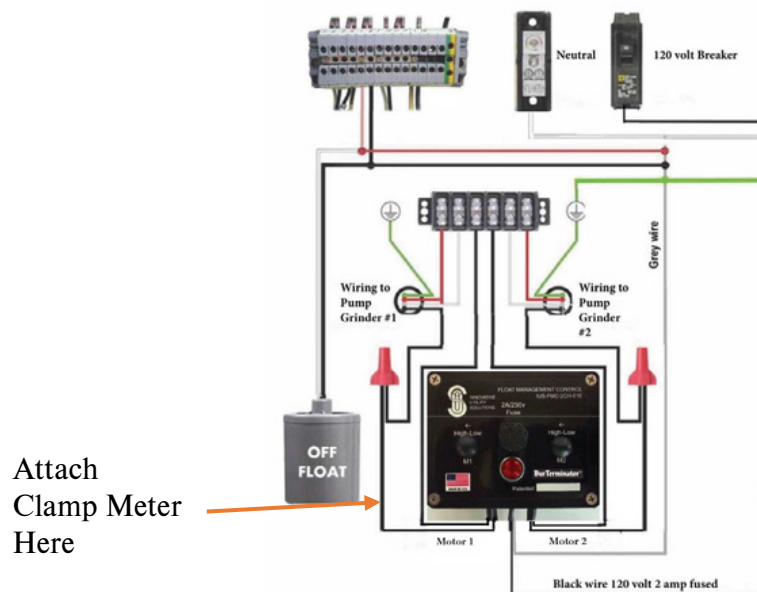

2. Turn on power to the Motor Circuit. If necessary, manually turn on the Pump.
3. Watch the current draw on the Clamp Meter.
4. Allow the Motor Pump to run for 10 to 15 seconds to get the current down to a stable, steady state level.
5. Remove the silicone button covering the Motor High-Low Adjustment Screw. Set it aside and do not lose it.

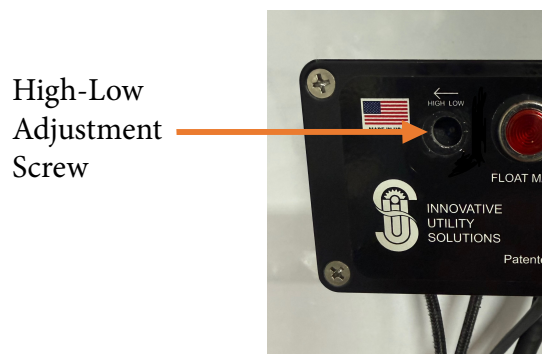
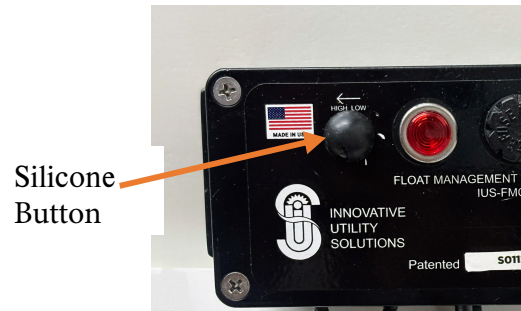

6. Run Motor Pump while using a Precision 5/64" Flathead Screwdriver on the Motor High-Low Adjustment Screw to make the adjustments.
7. Turn the High-Low Adjustment Screw counterclockwise slowly until you see the red light come on and stop. It may take several turns before the light comes on. If the light is on initially, proceed to step 8.
8. Slowly turn the High-Low Adjustment Screw clockwise until the red light goes off.
9. Again, slowly turn the High-Low Adjustment Screw counterclockwise until red light comes on and note this location.
10. Again, slowly turn the High-Low Adjustment Screw clockwise until red light goes off and note this location.
11. Turn the High-Low Adjustment Screw counterclockwise to the halfway point between the two positions and the red light should be off which will set the calibrated position of the FMC High-Low Adjustment Screw.
12. Remove the AC Clamp Meter.
13. Replace the silicone button that covers the Motor High-Low Adjustment Screw.
14. Close the Motor Control Panel.

Simplex



Duplex



**Power being run into utility panels is sufficient to cause serious injury or death. When it is necessary to work on equipment that is powered up, take all necessary and prudent safety precautions. Always assume that circuits are live until proven otherwise.**



***Ensure the floats for the motors give the motor an adequate amount of water around the motor to keep it cool while running. It is recommended that the final normal operating level of the water is to be no more than 2" below the top of the motor.***

## 8. APPLICABLE REFERENCES

### 1. Single-Phase and Three-Phase Wiring Diagram

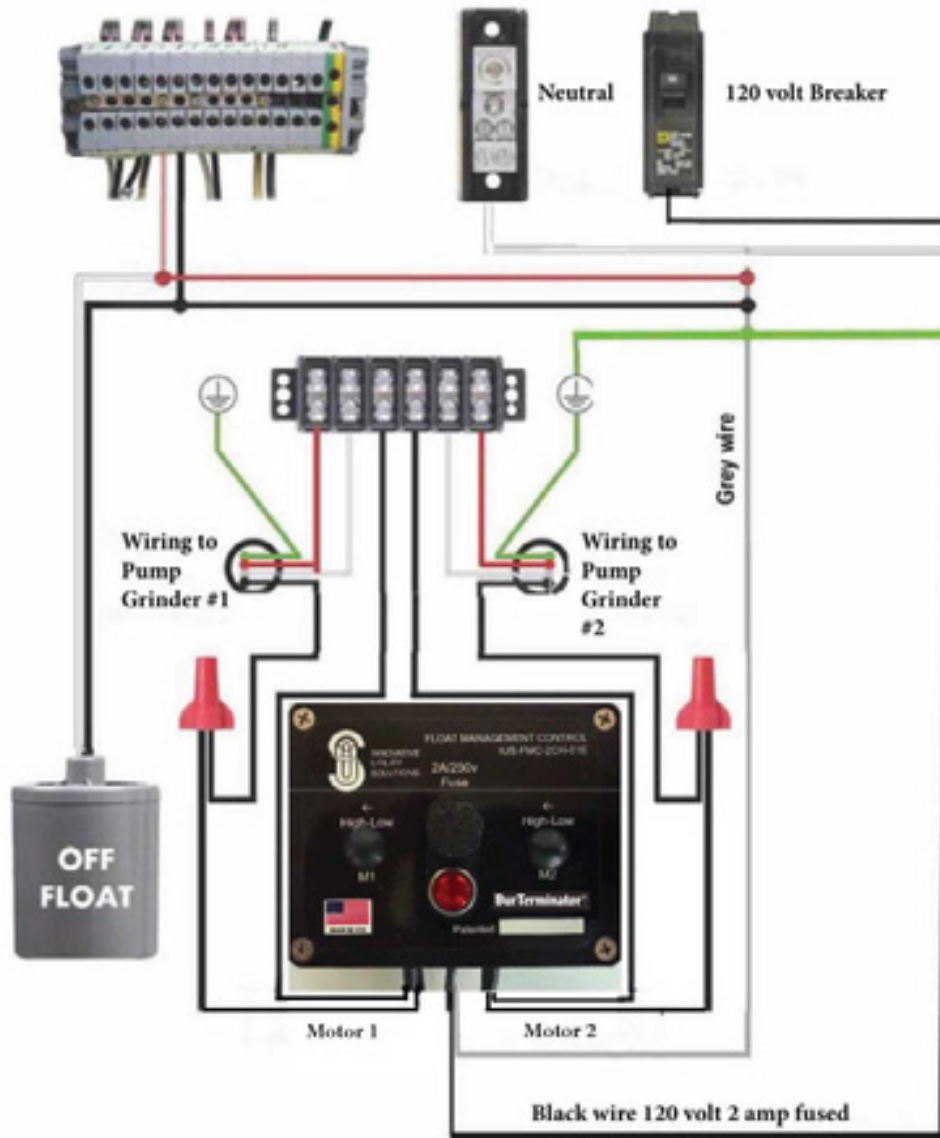

Single-Phase and Three-Phase Power Wiring Diagram