

FERRO / STEEL



Tool holders catalogue
Parts of your business



ims



Tool holders catalogue Parts of your business

May 2010

- I Edition: 30/03/1969 - Ed. Bidone
- II Edition: 30/03/1971 - Ed. IMS
- III Edition: 31/02/1972 - Ed. IMS
- IV Edition: 15/11/1973 - Ed. La Precisa
- V Edition: 15/11/1974 - Ed. G.F.
- VI Edition: 10/09/1980 - Ed. G.F.
- VII Edition: 30/07/1982 - Ed. Langa Grafica
- VIII Edition: 30/08/1983 - Ed. Langa Grafica
- IX Edition: 30/06/1986 - Ed. G.F.
- X Edition: 30/09/1988 - Ed. G.F.
- XI Edition: 30/03/2003 - Ed. Centro Stampa srl
- XII Edition: 15/09/2006 - Ed. L'Artistica Savigliano
- XIII Edition: 30/05/2010 - Ed. Rossano Adv



Industrial Fastening Systems

R.S. Johnston Industrial Fastening Systems
16 Diamond Road, Dromore, Co Down
BT25 1PH

Tel: +44 (0) 2892 699644

Fax: +44 (0) 2892 693498

Email info@rsjohnston.co.uk

Index

4-27	HSK A
28-44	HSK B
45-61	HSK C
62-78	HSK D
79-97	HSK E
98-117	HSK F
118-119	Accessories
120-162	ISO DIN 280
163-192	ISO BT
193-200	ISO BIG PLUS BT
201-231	ISO DIN 69871/A Stanimuc
232-234	ISO DIN 69871/A Big Plus
235-240	ISO DIN 69871/B
241-248	ISO CAT 40/50
249-254	Adjustable cylindrical tool holders - 1 diameter
255-261	Modular self docking tool holders
262-270	Tool holders with morse taper
271-272	Digital height measuring device
273	R8
274	Adaptor cylindrical shank to Weldon DIN 1835
275	Cylindrical shank
277-282	Tool holders for sharpening machineries
283-285	Rings
286-310	Collets
311-321	Nuts/Wrenches
322-323	Stiff tap collets
324-328	Accessories
329-379	Petal collets
380-396	Accessories
397-398	Broaches
399-401	Boring and facing heads
402	Face mill holders
403-420	VDI tool holders
421-430	Pull studs
431	Adaptor shrink fit
432	Release kit
433	Fingers
434	Special tool holders
435	Special tool holders
436-442	Tables



Code generator for HSK tool holders

HSK tool holders are very particular items, non suitable for a traditional catalogue: in order to identify the 48 versions (different shape and size) of every piece by a single code, without creating a reasonable confusion, we have chosen a modular code, easy to generate and understand.

Final code

HSK	63	F	091	1	4
A	B	C	D	E	F

MEANING OF CODE:

- A:** HSK abbreviation (page 7)
- B:** HSK size (page 20)
- C:** HSK connection (page 33)
- D:** Tool holder serial number (page 72)
- E:** Balancing (page 59)
- F:** Protective treatments (page 46)

HSK tool holders

Catalogue:

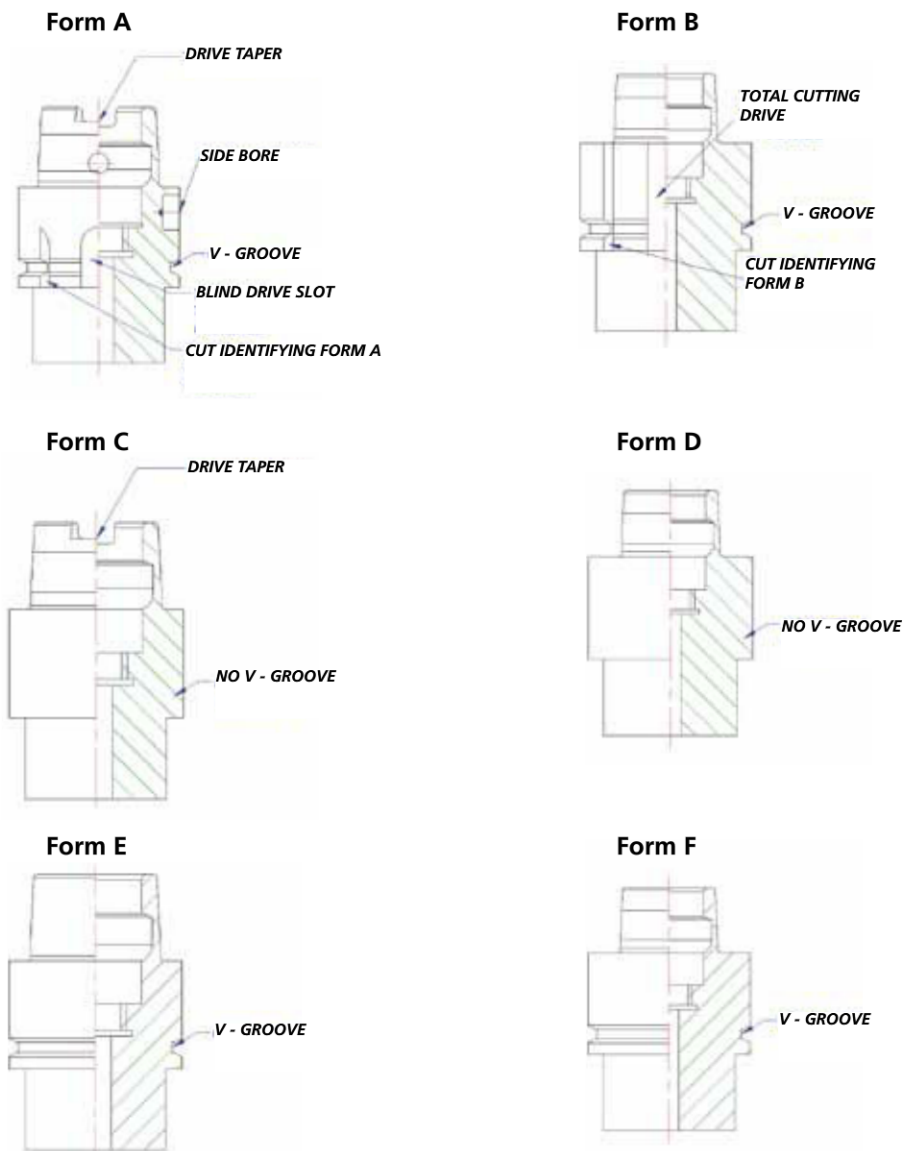

Special items provided on request

DIN 69893 tool holder sizes

Form A, C, E

Diameter (D)	Taper Diameter (D)	Taper length (L)
25	19	13
32	24	16
40	30	20
50	38	25
63	48	32
80	60	40
100	75	50
125	95	63
160	120	80

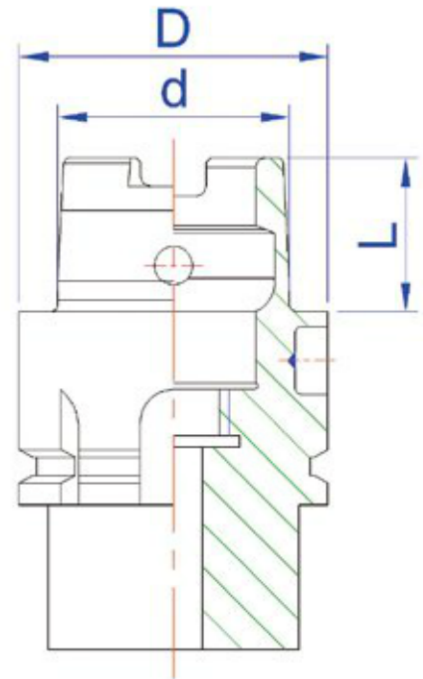

Form B, D, F

Diameter (D)	Taper Diameter (D)	Taper length (L)
32	19	13
40	24	16
50	30	20
63	38	25
80	48	32
100	60	40
125	75	50
160	95	63

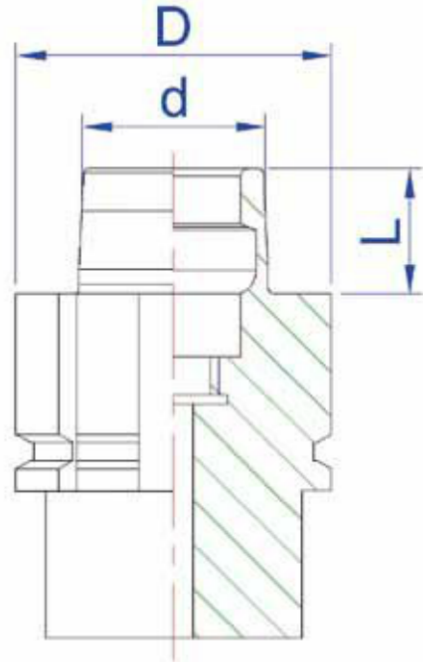

On equal external diameter of the flange (D), for forms A - C - E the larger taper diameter (d) is one size bigger than the other.

Special items provided on request



Tool holder HSK form A

Shell end mill holders

Code	d	L	I	D	HSK size
HSK32A29001	16	33	17	39	HSK-A-32
HSK32A29201	1/2"	3	0,56	1,35	HSK-A-32
HSK32A29202	3/4"	3	0,56	1,70	HSK-A-32
HSK40A29001	16	43	17	39	HSK-A-40
HSK40A29002	22	41	19	46	HSK-A-40
HSK40A29201	1/2"	3	0,56	1,35	HSK-A-40
HSK40A29202	3/4"	3	0,56	1,70	HSK-A-40
HSK40A29203	1"	3	0,67	2,20	HSK-A-40
HSK50A29001	16	53	17	39	HSK-A-50
HSK50A29002	22	51	19	46	HSK-A-50
HSK50A29003	27	69	21	55	HSK-A-50
HSK50A29004	32	61	24	63	HSK-A-50
HSK50A29201	1/2"	3	0,56	1,35	HSK-A-50
HSK50A29202	3/4"	3	0,56	1,70	HSK-A-50
HSK50A29203	1"	3	0,67	2,20	HSK-A-50
HSK50A29204	1"-1/4	4	0,70	2,20	HSK-A-50
HSK63A29001	16	63	17	39	HSK-A-63
HSK63A29002	22	61	19	46	HSK-A-63
HSK63A29003	27	69	21	55	HSK-A-63
HSK63A29004	32	66	24	63	HSK-A-63
HSK63A29005	40	73	27	78	HSK-A-63
HSK63A29201	1/2"	3	0,56	1,35	HSK-A-63
HSK63A29202	3/4"	3	0,56	1,70	HSK-A-63
HSK63A29203	1"	3	0,67	2,20	HSK-A-63
HSK63A29204	1"-1/4	4	0,70	2,20	HSK-A-63
HSK63A29205	1"-1/2	4	0,96	3,60	HSK-A-63
HSK80A29001	16	63	17	39	HSK-A-80
HSK80A29002	22	61	19	46	HSK-A-80
HSK80A29003	27	69	21	55	HSK-A-80
HSK80A29004	32	66	24	63	HSK-A-80
HSK80A29005	40	73	27	78	HSK-A-80
HSK80A29201	1/2"	3	0,56	1,35	HSK-A-80
HSK80A29202	3/4"	3	0,56	1,70	HSK-A-80
HSK80A29203	1"	3	0,67	2,20	HSK-A-80
HSK80A29204	1"-1/4	4	0,70	2,20	HSK-A-80
HSK80A29205	1"-1/2	4	0,96	3,60	HSK-A-80
HSK100A29001	16	73	17	39	HSK-A-100
HSK100A29002	22	71	19	46	HSK-A-100
HSK100A29003	27	69	21	55	HSK-A-100
HSK100A29004	32	66	24	63	HSK-A-100
HSK100A29005	40	73	27	78	HSK-A-100
HSK100A29201	1/2"	3	0,56	1,35	HSK-A-100
HSK100A29202	3/4"	3	0,56	1,70	HSK-A-100
HSK100A29203	1"	3	0,67	2,20	HSK-A-100
HSK100A29204	1"-1/4	4	0,70	2,20	HSK-A-100
HSK100A29205	1"-1/2	4	0,96	3,60	HSK-A-100
HSK100A29206	2"	4	1	4	HSK-A-100

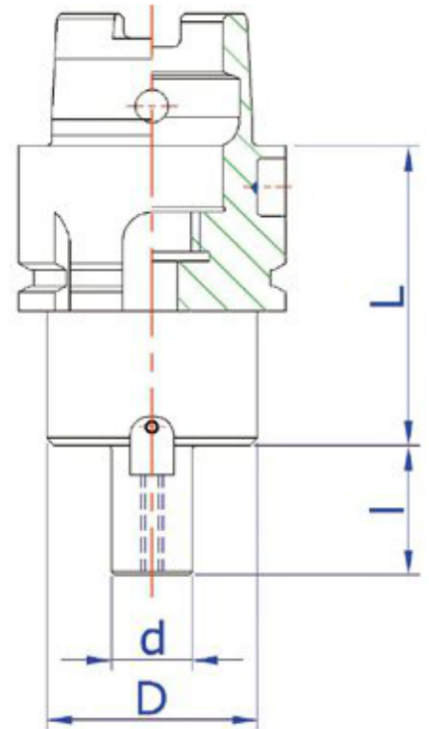

Special items provided on request

Tool holder HSK form A

Hydraulic collet chucks IMS type

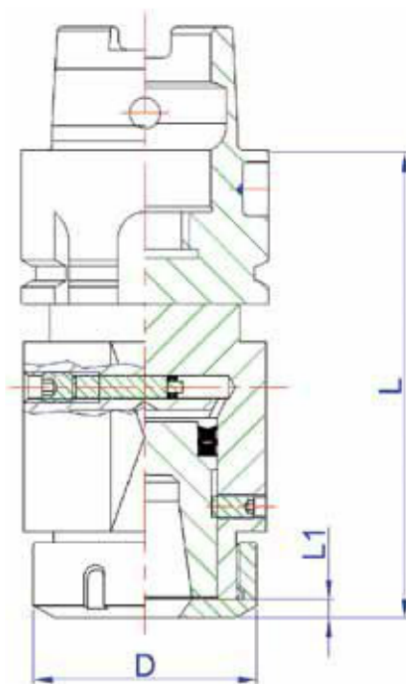

Code	Capacity	Collet	D	L	L1	HSK size
HSK50A29017	2 – 20	ER 32	63	80	12,5	HSK-A-50
HSK50A29018	3 – 30	ER 40	73	80	12,5	HSK-A-50
HSK63A29017	2 – 20	ER 32	63	80	12,5	HSK-A-63
HSK63A29018	3 – 30	ER 40	73	80	12,5	HSK-A-63
HSK80A29017	2 – 20	ER 32	63	80	12,5	HSK-A-80
HSK80A29018	3 – 30	ER 40	73	80	12,5	HSK-A-80
HSK100A29017	2 – 20	ER 32	63	80	12,5	HSK-A-100
HSK100A29018	3 – 30	ER 40	73	80	12,5	HSK-A-100
HSK125A29017	2 – 20	ER 32	63	80	12,5	HSK-A-125
HSK125A29018	3 – 30	ER 40	73	80	12,5	HSK-A-125
HSK160A29017	2 – 20	ER 32	63	80	12,5	HSK-A-160
HSK160A29018	3 – 30	ER 40	73	80	12,5	HSK-A-160

See pages 286/296 for ER collets

Special items provided on request



Tool holder HSK form A

Milling chucks

Code	Capacity	d	D	L	HSK size
HSK40A29031	6-32	32	75	95	HSK40A
HSK40A29032	4-20	20	50	70	HSK40A
HSK50A29031	6-32	32	75	95	HSK50A
HSK50A29032	4-20	20	50	70	HSK50A
HSK63A29031	6-32	32	75	95	HSK63A
HSK63A29032	4-20	20	50	70	HSK63A
HSK80A29031	6-32	32	75	95	HSK80A
HSK80A29032	4-20	20	50	70	HSK80A
HSK100A29031	6-32	32	75	95	HSK100A
HSK125A29031	6-32	32	75	150	HSK125A

See page 308 for cylindrical collets

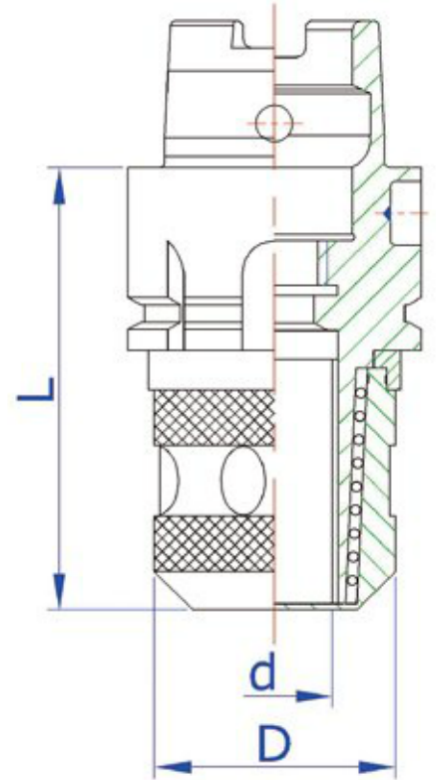

Special items provided on request

Tool holder HSK form A Collet chucks for ER collets

Code	Capacity	Collet	L Min.	D	HSK size
HSK32A29021	1-5	ER 8	60	12	HSK-A-32
HSK32A29022	1-7	ER 11	60	16	HSK-A-32
HSK32A29024	1-10	ER16	60	22	HSK-A-32
HSK40A29021	1-5	ER 8	60	12	HSK-A-40
HSK40A29022	1-7	ER 11	60	16	HSK-A-40
HSK40A29024	1-10	ER 16	60	22	HSK-A-40
HSK40A29025	1-13	ER 20	70	28	HSK-A-40
HSK40A29026	1-16	ER 25	70	42	HSK-A-40
HSK40A29027	2-20	ER 32	70	50	HSK-A-40
HSK50A29021	1-5	ER 8	70	12	HSK-A-50
HSK50A29022	1-7	ER 11	70	16	HSK-A-50
HSK50A29024	1-10	ER 16	70	22	HSK-A-50
HSK50A29025	1-13	ER 20	70	28	HSK-A-50
HSK50A29026	1-16	ER 25	70	42	HSK-A-50
HSK50A29027	2-20	ER 32	70	50	HSK-A-50
HSK50A29028	3-30	ER 40	70	63	HSK-A-50
HSK63A29021	1-5	ER 8	70	12	HSK-A-63
HSK63A29022	1-7	ER 11	70	16	HSK-A-63
HSK63A29024	1-10	ER 16	70	22	HSK-A-63
HSK63A29025	1-13	ER 20	70	28	HSK-A-63
HSK63A29026	1-16	ER 25	70	42	HSK-A-63
HSK63A29027	2-20	ER 32	70	50	HSK-A-63
HSK63A29028	3-30	ER 40	70	53	HSK-A-63
HSK63A29029	6-34	ER 50	70	78	HSK-A-63
HSK63A29030	2-25	ORT 25	70	60	HSK-A-63
HSK80A29025	1-13	ER 20	70	28	HSK-A-80
HSK80A29026	1-16	ER 25	70	42	HSK-A-80
HSK80A29027	2-20	ER 32	70	50	HSK-A-80
HSK80A29028	3-30	ER 40	70	63	HSK-A-80
HSK80A29029	6-34	ER 50	70	78	HSK-A-80
HSK80A29030	8-40	ER 60	70	90	HSK-A-80
HSK100A29026	1-16	ER 25	70	42	HSK-A-100
HSK100A29027	2-20	ER 32	70	50	HSK-A-100
HSK100A29028	3-30	ER 40	70	63	HSK-A-100
HSK100A29029	6-34	ER 50	70	78	HSK-A-100
HSK100A29030	8-40	ER 60	70	90	HSK-A-100
HSK100A29031	2-25	ORT 25	70	60	HSK-A-100
HSK100A29032	4-32	ORT 32	100	78	HSK-A-100
HSK125A29028	2-20	ER 40	140	63	HSK-A-125
HSK125A29029	3-30	ER 50	140	78	HSK-A-125
HSK125A29030	6-34	ER 60	140	90	HSK-A-125
HSK160A29028	3-30	ER 40	180	63	HSK-A-160
HSK160A29031	2-25	ORT 25	100	60	HSK-A-160
HSK160A29032	4-32	ORT 32	100	78	HSK-A-160
HSK160A29030	6-34	ER 60	120	90	HSK-A-160

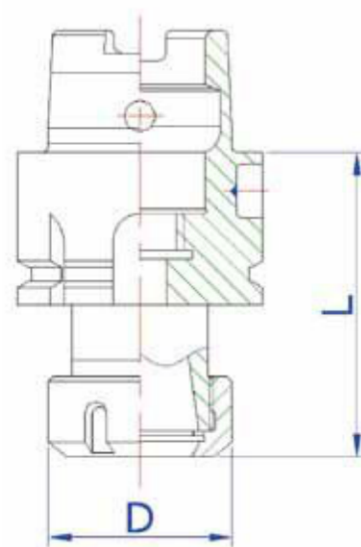

See pages 286/296 for ER collets

Special items provided on request



Tool holder HSK form A

Extra short ER collet chucks with inner nut

Code	Capacity	Collet	L	D	M	HSK size
HSK50A29048	1 – 20	ER 32	60	60	40X1,5	HSK-A-50
HSK50A29049	3 – 25	ER 40	70	70	50X1,5	HSK-A-50
HSK63A29048	1 – 20	ER 32	60	60	40X1,5	HSK-A-63
HSK63A29049	3 – 25	ER 40	70	70	50X1,5	HSK-A-63
HSK80A29048	1 – 20	ER 32	70	60	40X1,5	HSK-A-80
HSK80A29049	3 – 25	ER 40	80	70	50X1,5	HSK-A-80
HSK100A29048	1 – 20	ER 32	80	60	40X1,5	HSK-A-100
HSK100A29049	3 – 25	ER 40	90	70	50X1,5	HSK-A-100

See pages 286/296 for ER collets

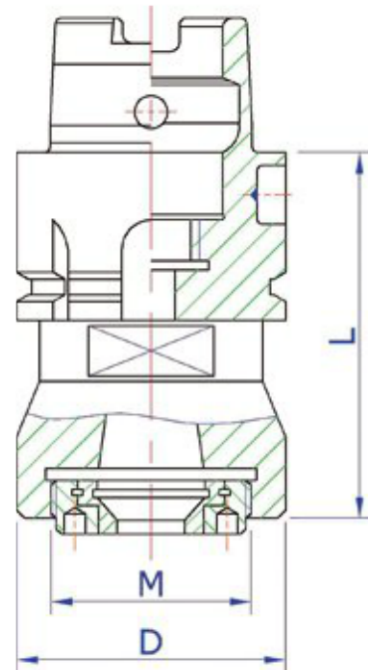

Special items provided on request

Tool holder HSK form A

Hydraulic chuck for end mill

Code	d	D	L	HSK size
HSK32A29060	6	26	80	HSK-A-32
HSK32A29065	8	30	85	HSK-A-32
HSK32A29062	10	30	85	HSK-A-32
HSK32A29063	12	32	90	HSK-A-32
HSK32A29061	1"	50	100	HSK-A-32
HSK40A29060	6	26	80	HSK-A-40
HSK40A29065	8	30	85	HSK-A-40
HSK40A29062	10	30	85	HSK-A-40
HSK40A29063	12	32	90	HSK-A-40
HSK40A29064	1/4"	1/2"	70	HSK-A-40
HSK40A29061	1"	50	100	HSK-A-40
HSK50A29060	6	26	80	HSK-A-50
HSK50A29066	8	30	85	HSK-A-50
HSK50A29062	10	30	85	HSK-A-50
HSK50A29063	12	32	90	HSK-A-50
HSK50A29064	14	34	90	HSK-A-50
HSK50A29065	16	38	95	HSK-A-50
HSK50A29067	20	42	100	HSK-A-50
HSK50A29068	3/8"	3/8"	70	HSK-A-50
HSK50A29061	1"	50	100	HSK-A-50
HSK63A29060	6	26	80	HSK-A-63
HSK63A29071	8	30	85	HSK-A-63
HSK63A29062	10	30	85	HSK-A-63
HSK63A29063	12	32	90	HSK-A-63
HSK63A29065	16	38	95	HSK-A-63
HSK63A29067	20	42	100	HSK-A-63
HSK63A29068	25	50	120	HSK-A-63
HSK63A29069	32	60	125	HSK-A-63
HSK63A29070	1/2"	1/2"	80	HSK-A-63
HSK63A29061	1"	50	100	HSK-A-63
HSK80A29060	6	26	85	HSK-A-80
HSK80A29071	8	30	85	HSK-A-80
HSK80A29062	10	30	90	HSK-A-80
HSK80A29063	12	32	95	HSK-A-80
HSK80A29065	16	38	100	HSK-A-80
HSK80A29067	20	42	105	HSK-A-80
HSK80A29068	25	50	115	HSK-A-80
HSK80A29069	32	60	120	HSK-A-80
HSK80A29070	3/4"	3/4"	90	HSK-A-80
HSK80A29061	1"	50	100	HSK-A-80
HSK100A29060	6	26	85	HSK-A-100
HSK100A29071	8	30	85	HSK-A-100
HSK100A29062	10	30	90	HSK-A-100
HSK100A29063	12	32	95	HSK-A-100
HSK100A29065	16	38	100	HSK-A-100
HSK100A29067	20	42	105	HSK-A-100
HSK100A29068	25	50	115	HSK-A-100
HSK100A29069	32	60	120	HSK-A-100
HSK100A29070	1"	1"	110	HSK-A-100

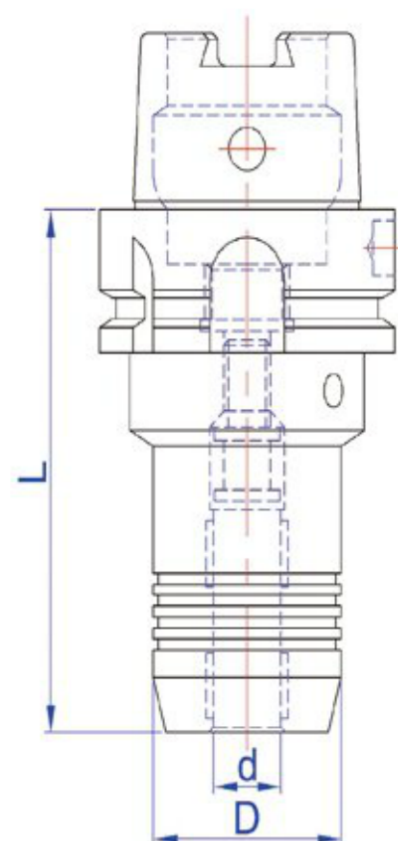

See page 309 for ER collets

Special items provided on request



Tool holder HSK form A Long version ER collet chucks with mini nut

Code	Capacity	Collet	L Min.	D	HSK size
HSK25A29041	1 – 5	ER8	100	12	HSK-A-25
HSK25A29042	1 – 7	ER11	100	16	HSK-A-25
HSK25A29043	1 – 10	ER16	100	22	HSK-A-25
HSK25A29044	1 – 13	ER20	100	28	HSK-A-25
HSK25A29045	1 – 16	ER25	100	35	HSK-A-25
HSK32A29041	1 – 5	ER8	100	12	HSK-A-32
HSK32A29042	1 – 7	ER11	100	16	HSK-A-32
HSK32A29043	1 – 10	ER16	100	22	HSK-A-32
HSK32A29044	1 – 13	ER20	100	28	HSK-A-32
HSK32A29045	1 – 16	ER25	100	35	HSK-A-32
HSK40A29041	1 – 5	ER8	100	12	HSK-A-40
HSK40A29042	1 – 7	ER11	100	16	HSK-A-40
HSK40A29043	1 – 10	ER16	100	22	HSK-A-40
HSK40A29044	1 – 13	ER20	100	28	HSK-A-40
HSK40A29045	1 – 16	ER25	100	35	HSK-A-40
HSK50A29041	1 – 5	ER8	160	12	HSK-A-50
HSK50A29042	1 – 7	ER11	160	16	HSK-A-50
HSK50A29043	1 – 10	ER16	160	22	HSK-A-50
HSK50A29044	1 – 13	ER20	160	28	HSK-A-50
HSK50A29045	1 – 16	ER25	160	35	HSK-A-50
HSK63A29041	1 – 5	ER8	160	12	HSK-A-63
HSK63A29042	1 – 7	ER11	160	16	HSK-A-63
HSK63A29043	1 – 10	ER16	160	22	HSK-A-63
HSK63A29044	1 – 13	ER20	160	28	HSK-A-63
HSK63A29045	1 – 16	ER25	160	35	HSK-A-63
HSK80A29041	1 – 5	ER8	160	12	HSK-A-80
HSK80A29042	1 – 7	ER11	160	16	HSK-A-80
HSK80A29043	1 – 10	ER16	160	22	HSK-A-80
HSK80A29044	1 – 13	ER20	160	28	HSK-A-80
HSK80A29045	1 – 16	ER25	160	35	HSK-A-80
HSK100A29041	1 – 5	ER8	160	12	HSK-A-100
HSK100A29042	1 – 7	ER11	160	16	HSK-A-100
HSK100A29043	1 – 10	ER16	160	22	HSK-A-100
HSK100A29044	1 – 13	ER20	160	28	HSK-A-100
HSK100A29045	1 – 16	ER25	160	35	HSK-A-100
HSK125A29043	1 – 10	ER16	160	22	HSK-A-125
HSK125A29045	1 – 16	ER25	160	35	HSK-A-125

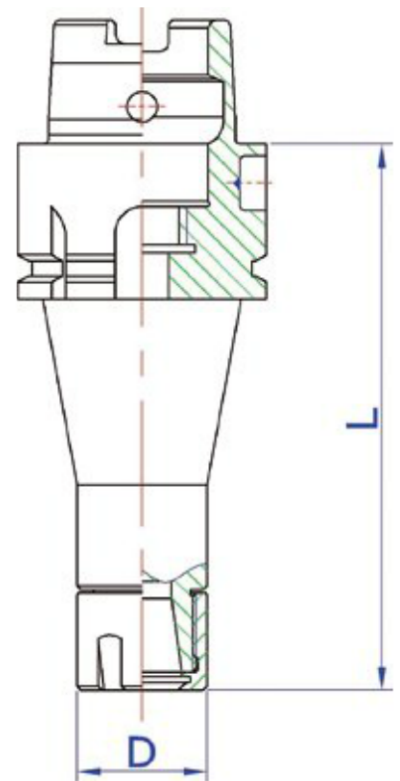

See pages 286/296 for ER collets

Special items provided on request

Tool holder HSK form A tap holder with tension and compression BILZ type

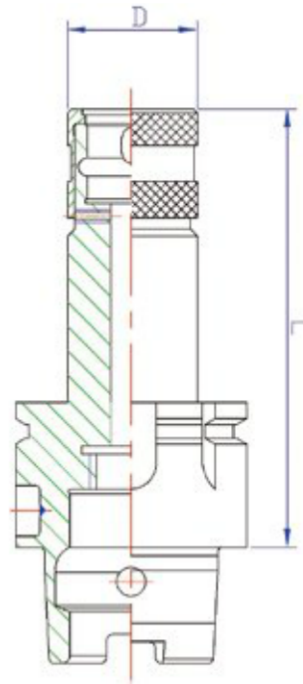

Code	Cap.	Collet size	Tens.	Comp.	L	D	HSK size
HSK40A29071	M3-M12	WE1	7	5	90	32	HSK-A-40
HSK50A29071	M3-M12	WE1	7	5	90	32	HSK-A-50
HSK50A29072	M9-M24	WE2	15	8	120	50	HSK-A-50
HSK63A29071	M3-M12	WE1	7	5	90	32	HSK-A-63
HSK63A29072	M9-M24	WE2	15	8	110	50	HSK-A-63
HSK63A29073	M16-M33	WE3	25	10	120	72	HSK-A-63
HSK80A29071	M3-M12	WE1	7	5	90	32	HSK-A-80
HSK80A29072	M9-M24	WE2	15	8	110	50	HSK-A-80
HSK80A29073	M16-M33	WE3	25	10	120	72	HSK-A-80
HSK80A29074	M24-M60	WE4	25	15	200	92	HSK-A-80
HSK100A29071	M3-M12	WE1	7	5	90	32	HSK-A-100
HSK100A29072	M9-M24	WE2	15	8	110	50	HSK-A-100
HSK100A29073	M16-M33	WE3	25	10	120	72	HSK-A-100
HSK100A29074	M24-M60	WE4	25	15	210	92	HSK-A-100

See pages 321/322 for tap collets.
It's advisable to use clutch tap collets.

Special items provided on request



Tool holder HSK form A

Tap holder fixed size BILZ type

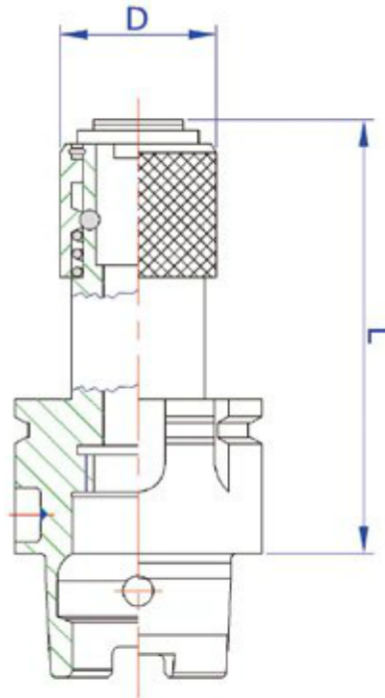

Code	Capacity	Collet Size	L	D	HSK size
HSK40A29076	M3-M12	WE1	70	32	HSK-A-40
HSK50A29076	M3-M12	WE1	70	32	HSK-A-50
HSK50A29077	M9-M24	WE2	90	50	HSK-A-50
HSK63A29076	M3-M12	WE1	70	32	HSK-A-63
HSK63A29077	M9-M24	WE2	90	50	HSK-A-63
HSK63A29078	M16-M33	WE3	100	72	HSK-A-63
HSK80A29076	M3-M12	WE1	70	32	HSK-A-80
HSK80A29077	M9-M24	WE2	90	50	HSK-A-80
HSK80A29078	M16-M33	WE3	100	72	HSK-A-80
HSK80A29079	M24-M60	WE4	150	92	HSK-A-80
HSK100A29076	M3-M12	WE1	70	32	HSK-A-100
HSK100A29077	M9-M24	WE2	90	50	HSK-A-100
HSK100A29078	M16-M33	WE3	100	72	HSK-A-100
HSK100A29079	M24-M60	WE4	160	92	HSK-A-100

See pages 321/322 for tap collets.
It's advisable to use clutch tap collets.

Special items provided on request

Tool holder HSK form A

Morse taper reduction sleeve with tang

Code	Morse taper	L	D	HSK size
HSK32A29081	1	90	35	HSK-A-32
HSK40A29081	1	110	35	HSK-A-40
HSK40A29082	2	110	35	HSK-A-40
HSK50A29081	1	90	35	HSK-A-50
HSK50A29082	2	110	35	HSK-A-50
HSK50A29083	3	130	42	HSK-A-50
HSK63A29081	1	90	35	HSK-A-63
HSK63A29082	2	110	35	HSK-A-63
HSK63A29083	3	160	42	HSK-A-63
HSK63A29084	4	160	52	HSK-A-63
HSK63A29085	5	200	70	HSK-A-63
HSK80A29081	1	90	35	HSK-A-80
HSK80A29082	2	110	35	HSK-A-80
HSK80A29083	3	140	42	HSK-A-80
HSK80A29084	4	160	52	HSK-A-80
HSK80A29085	5	200	70	HSK-A-80
HSK100A29081	1	90	35	HSK-A-100
HSK100A29082	2	110	35	HSK-A-100
HSK100A29083	3	140	42	HSK-A-100
HSK100A29084	4	160	52	HSK-A-100
HSK100A29085	5	200	70	HSK-A-100
HSK100A29086	6	260	90	HSK-A-100

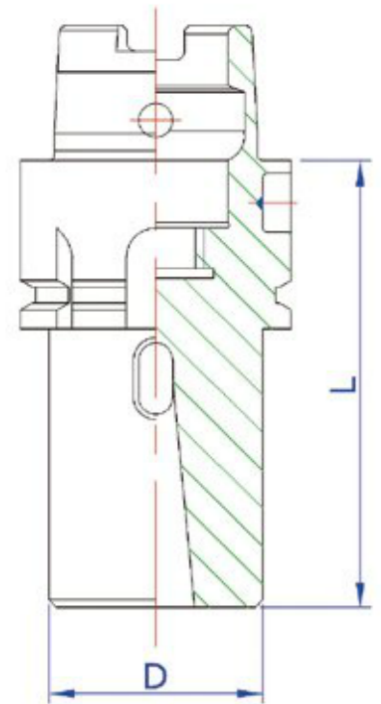

Special items provided on request



Tool holder HSK form A

Morse taper reduction sleeve with thread

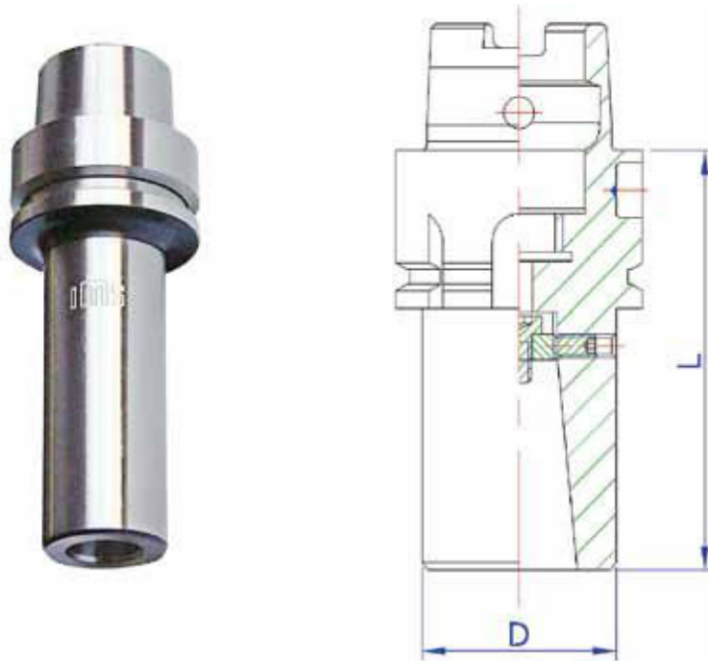

Code	Morse taper	L	D	HSK size
HSK40A29087	2	110	35	HSK-A-40
HSK50A29087	2	110	35	HSK-A-50
HSK50A29088	3	130	42	HSK-A-50
HSK63A29087	2	110	35	HSK-A-63
HSK63A29088	3	160	42	HSK-A-63
HSK63A29089	4	200	52	HSK-A-63
HSK80A29087	2	110	35	HSK-A-80
HSK80A29088	3	140	42	HSK-A-80
HSK80A29089	4	200	52	HSK-A-80
HSK100A29087	2	110	35	HSK-A-100
HSK100A29088	3	140	42	HSK-A-100
HSK100A29089	4	200	52	HSK-A-100
HSK100A29090	5	200	65	HSK-A-100

Special items provided on request

Tool holder HSK form A automatic locking end mill holder

Automatic locking system tool holders for high speed

The tool has to be plugged by hand.

To block it, just turn it by hand, clock wise;

to unlock it, just turn it anti clockwise.

Code	D	d	L	HSK size
HSK40A29102	18	6	63	HSK-A-40
HSK40A29104	25	8	63	HSK-A-40
HSK40A29105	25	10	63	HSK-A-40
HSK40A29106	28	12	63	HSK-A-40
HSK40A29108	34	16	63	HSK-A-40
HSK40A29110	39	20	63	HSK-A-40
HSK40A29112	39	25	80	HSK-A-40
HSK50A29102	18	6	63	HSK-A-50
HSK50A29104	25	8	63	HSK-A-50
HSK50A29105	25	10	63	HSK-A-50
HSK50A29106	28	12	63	HSK-A-50
HSK50A29108	34	16	63	HSK-A-50
HSK50A29110	39	20	63	HSK-A-50
HSK50A29112	39	25	80	HSK-A-50
HSK80A29102	18	6	63	HSK-A-80
HSK80A29104	25	8	63	HSK-A-80
HSK80A29105	25	10	63	HSK-A-80
HSK80A29106	28	12	63	HSK-A-80
HSK80A29108	34	16	63	HSK-A-80
HSK80A29110	39	20	63	HSK-A-80
HSK80A29112	39	25	80	HSK-A-80
HSK63A29102	18	6	63	HSK-A-63
HSK63A29104	25	8	63	HSK-A-63
HSK63A29105	25	10	63	HSK-A-63
HSK63A29106	28	12	63	HSK-A-63
HSK63A29108	34	16	63	HSK-A-63
HSK63A29110	39	20	63	HSK-A-63
HSK63A29112	39	25	80	HSK-A-63
HSK100A29102	18	6	120	HSK-A-100
HSK100A29104	25	8	120	HSK-A-100
HSK100A29105	25	10	120	HSK-A-100
HSK100A29106	28	12	120	HSK-A-100
HSK100A29108	34	16	120	HSK-A-100
HSK100A29110	39	20	120	HSK-A-100
HSK100A29112	39	25	120	HSK-A-100

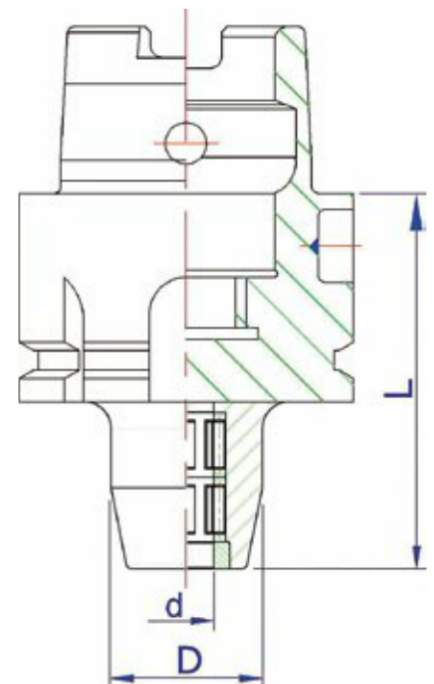

Special items provided on request



Tool holder HSK form A

End mill holder WHISTLE NOTCH

Code	d	D	L	HSK size
HSK32A2909100	6	22	70	HSK-A-32
HSK32A2909101	8	28	70	HSK-A-32
HSK32A2909301	1/4"	22	70	HSK-A-32
HSK32A2909302	3/8"	35	70	HSK-A-32
HSK32A2909303	1/2"	42	70	HSK-A-32
HSK32A2909304	3/4"	110	52	HSK-A-32
HSK32A2909305	1"	110	65	HSK-A-32
HSK40A2909100	6	22	70	HSK-A-40
HSK40A2909101	8	28	70	HSK-A-40
HSK40A2909102	10	35	70	HSK-A-40
HSK40A2909301	1/4"	22	70	HSK-A-40
HSK40A2909302	3/8"	35	70	HSK-A-40
HSK40A2909303	1/2"	42	70	HSK-A-40
HSK40A2909304	3/4"	52	110	HSK-A-40
HSK40A2909305	1"	65	110	HSK-A-40
HSK50A2909100	6	22	70	HSK-A-50
HSK50A2909101	8	28	70	HSK-A-50
HSK50A2909102	10	35	70	HSK-A-50
HSK50A2909103	12	42	70	HSK-A-50
HSK50A2909104	16	48	70	HSK-A-50
HSK50A2909105	20	52	70	HSK-A-50
HSK50A2909301	1/4"	22	70	HSK-A-50
HSK50A2909302	3/8"	35	70	HSK-A-50
HSK50A2909303	1/2"	42	70	HSK-A-50
HSK50A2909304	3/4"	52	110	HSK-A-50
HSK50A2909305	1"	65	110	HSK-A-50
HSK63A2909100	6	22	70	HSK-A-63
HSK63A2909101	8	28	70	HSK-A-63
HSK63A2909102	10	35	70	HSK-A-63
HSK63A2909103	12	42	70	HSK-A-63
HSK63A2909104	16	48	70	HSK-A-63
HSK63A2909105	20	52	70	HSK-A-63
HSK63A2909106	25	65	110	HSK-A-63
HSK63A2909107	32	70	110	HSK-A-63
HSK63A2909301	1/4"	22	70	HSK-A-63
HSK63A2909302	3/8"	35	70	HSK-A-63
HSK63A2909303	1/2"	42	70	HSK-A-63
HSK63A2909304	3/4"	52	110	HSK-A-63
HSK63A2909305	1"	65	110	HSK-A-63
HSK80A2909100	6	22	70	HSK-A-80
HSK80A2909101	8	28	70	HSK-A-80
HSK80A2909102	10	35	70	HSK-A-80
HSK80A2909103	12	42	70	HSK-A-80
HSK80A2909104	16	48	70	HSK-A-80
HSK80A2909105	20	52	70	HSK-A-80
HSK80A2909106	25	65	110	HSK-A-80
HSK80A2909107	32	70	110	HSK-A-80
HSK80A2909108	40	70	110	HSK-A-80
HSK80A2909109	50	80	110	HSK-A-80
HSK80A2909301	1/4"	22	70	HSK-A-80
HSK80A2909302	3/8"	35	70	HSK-A-80
HSK80A2909303	1/2"	42	70	HSK-A-80
HSK80A2909304	3/4"	52	110	HSK-A-80
HSK80A2909305	1"	65	110	HSK-A-80
HSK100A2909100	6	22	70	HSK-A-100
HSK100A2909101	8	28	70	HSK-A-100
HSK100A2909102	10	35	70	HSK-A-100
HSK100A2909103	12	42	70	HSK-A-100
HSK100A2909104	16	48	70	HSK-A-100
HSK100A2909105	20	52	70	HSK-A-100
HSK100A2909106	25	65	110	HSK-A-100
HSK100A2909107	32	70	110	HSK-A-100
HSK100A2909108	40	70	110	HSK-A-100
HSK100A2909109	50	80	110	HSK-A-100
HSK100A2909301	1/4"	22	70	HSK-A-100
HSK100A2909302	3/8"	35	70	HSK-A-100
HSK100A2909303	1/2"	42	70	HSK-A-100
HSK100A2909304	3/4"	52	110	HSK-A-100
HSK100A2909305	1"	65	110	HSK-A-100

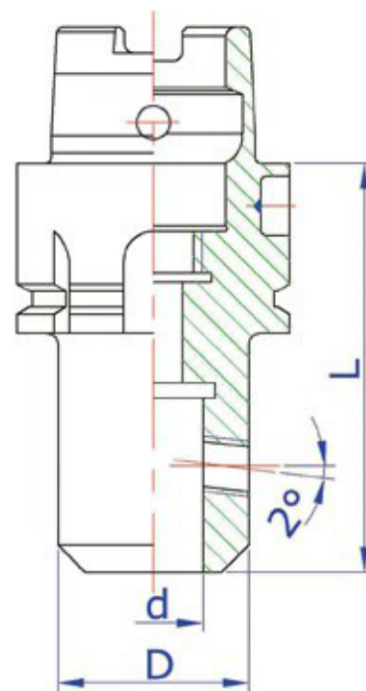

Special items provided on request

Tool holder HSK form A

Weldon end mill holders

Code	d	D	L	HSK size
HSK32A29090	6	22	70	HSK-A-32
HSK32A29091	8	28	70	HSK-A-32
HSK32A29291	1/4"	22	70	HSK-A-32
HSK32A29292	3/8"	35	70	HSK-A-32
HSK32A29293	1/2"	42	70	HSK-A-32
HSK40A29090	6	22	70	HSK-A-40
HSK40A29091	8	28	70	HSK-A-40
HSK40A29092	10	35	70	HSK-A-40
HSK40A29291	1/4"	22	70	HSK-A-40
HSK40A29292	3/8"	35	70	HSK-A-40
HSK40A29293	1/2"	70	42	HSK-A-40
HSK40A29294	3/4"	52	110	HSK-A-40
HSK40A29295	1"	65	110	HSK-A-40
HSK50A29090	6	22	70	HSK-A-50
HSK50A29091	8	28	70	HSK-A-50
HSK50A29092	10	35	70	HSK-A-50
HSK50A29093	12	42	70	HSK-A-50
HSK50A29094	16	48	70	HSK-A-50
HSK50A29095	20	52	70	HSK-A-50
HSK50A29291	1/4"	22	70	HSK-A-50
HSK50A29292	3/8"	35	70	HSK-A-50
HSK50A29293	1/2"	70	42	HSK-A-50
HSK50A29294	3/4"	52	110	HSK-A-50
HSK50A29295	1"	65	110	HSK-A-50
HSK63A29090	6	22	70	HSK-A-63
HSK63A29091	8	28	70	HSK-A-63
HSK63A29092	10	35	70	HSK-A-63
HSK63A29093	12	42	70	HSK-A-63
HSK63A29094	16	48	70	HSK-A-63
HSK63A29095	20	52	70	HSK-A-63
HSK63A29096	25	65	110	HSK-A-63
HSK63A29097	32	70	110	HSK-A-63
HSK63A29291	1/4"	22	70	HSK-A-63
HSK63A29292	3/8"	35	70	HSK-A-63
HSK63A29293	1/2"	70	42	HSK-A-63
HSK63A29294	3/4"	52	110	HSK-A-63
HSK63A29295	1"	65	110	HSK-A-63
HSK80A29090	6	22	70	HSK-A-80
HSK80A29091	8	28	70	HSK-A-80
HSK80A29092	10	35	70	HSK-A-80
HSK80A29093	12	42	70	HSK-A-80
HSK80A29094	16	48	70	HSK-A-80
HSK80A29095	20	52	70	HSK-A-80
HSK80A29096	25	65	110	HSK-A-80
HSK80A29097	32	70	110	HSK-A-80
HSK80A29098	40	70	110	HSK-A-80
HSK80A29099	50	80	110	HSK-A-80
HSK80A29291	1/4"	22	70	HSK-A-80
HSK80A29292	3/8"	35	70	HSK-A-80
HSK80A29293	1/2"	70	42	HSK-A-80
HSK80A29294	3/4"	52	110	HSK-A-80
HSK80A29295	1"	65	110	HSK-A-80
HSK100A29090	6	22	70	HSK-A-100
HSK100A29091	8	28	70	HSK-A-100
HSK100A29092	10	35	70	HSK-A-100
HSK100A29093	12	42	70	HSK-A-100
HSK100A29094	16	48	70	HSK-A-100
HSK100A29095	20	52	70	HSK-A-100
HSK100A29096	25	65	110	HSK-A-100
HSK100A29097	32	70	110	HSK-A-100
HSK100A29098	40	70	110	HSK-A-100
HSK100A29099	50	80	110	HSK-A-100
HSK100A29291	1/4"	22	70	HSK-A-100
HSK100A29292	3/8"	35	70	HSK-A-100
HSK100A29293	1/2"	70	42	HSK-A-100
HSK100A29294	3/4"	52	110	HSK-A-100
HSK100A29295	1"	65	110	HSK-A-100

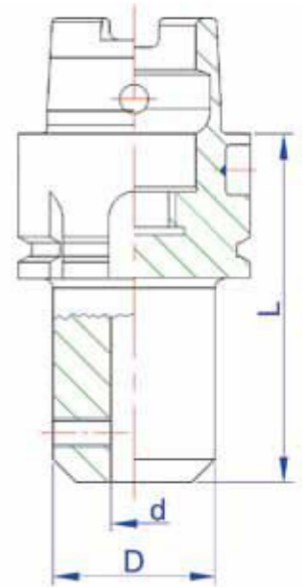

Special items provided on request



Tool holder HSK form A

Shrink fit end mill holders

Code	d	D	L	HSK size
HSK32A29120	6	27	95	HSK-A-32
HSK32A29121	8	28	95	HSK-A-32
HSK32A29122	10	29	95	HSK-A-32
HSK32A29123	12	29	95	HSK-A-32
HSK32A29321	1/4"	22	95	HSK-A-32
HSK32A29322	3/8"	35	95	HSK-A-32
HSK32A29323	1/2"	42	95	HSK-A-32
HSK32A29324	3/4"	52	95	HSK-A-32
HSK32A29325	1"	65	120	HSK-A-32
HSK40A29120	6	27	95	HSK-A-40
HSK40A29121	8	28	95	HSK-A-40
HSK40A29122	10	32	95	HSK-A-40
HSK40A29123	12	32	95	HSK-A-40
HSK40A29124	16	34	95	HSK-A-40
HSK40A29321	1/4"	22	95	HSK-A-40
HSK40A29322	3/8"	35	95	HSK-A-40
HSK40A29323	1/2"	42	95	HSK-A-40
HSK40A29324	3/4"	52	95	HSK-A-40
HSK40A29325	1"	65	120	HSK-A-40
HSK50A29120	6	27	80	HSK-A-50
HSK50A29121	8	28	95	HSK-A-50
HSK50A29122	10	32	85	HSK-A-50
HSK50A29123	12	32	90	HSK-A-50
HSK50A29124	16	34	95	HSK-A-50
HSK50A29125	20	42	100	HSK-A-50
HSK50A29321	1/4"	22	70	HSK-A-50
HSK50A29322	3/8"	35	70	HSK-A-50
HSK50A29323	1/2"	42	70	HSK-A-50
HSK50A29324	3/4"	52	95	HSK-A-50
HSK50A29325	1"	65	95	HSK-A-50
HSK63A29120	6	27	95	HSK-A-63
HSK63A29121	8	28	95	HSK-A-63
HSK63A29122	10	32	95	HSK-A-63
HSK63A29123	12	32	95	HSK-A-63
HSK63A29124	16	34	95	HSK-A-63
HSK63A29125	20	42	95	HSK-A-63
HSK63A29126	25	53	120	HSK-A-63
HSK63A29127	32	53	95	HSK-A-63
HSK63A29131	1/4"	27	95	HSK-A-63
HSK63A29132	3/8"	32	95	HSK-A-63
HSK63A29133	1/2"	32	95	HSK-A-63
HSK63A29134	5/8"	34	95	HSK-A-63
HSK63A29135	3/4"	42	95	HSK-A-63
HSK63A29136	1"	53	120	HSK-A-63
HSK63A29137	1-1/4"	53	95	HSK-A-63

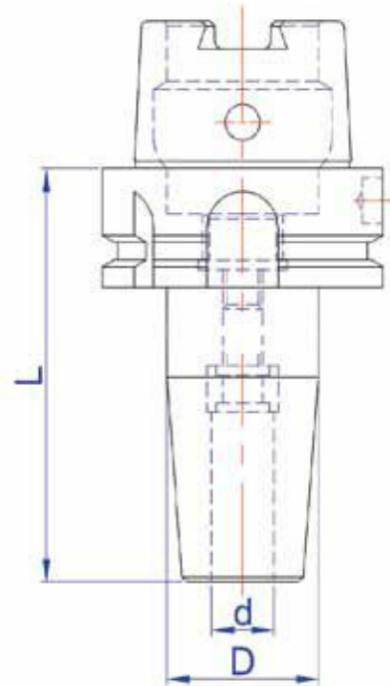

Code	d	D	L	HSK size
HSK80A29120	6	27	85	HSK-A-80
HSK80A29121	8	28	95	HSK-A-80
HSK80A29122	10	32	90	HSK-A-80
HSK80A29123	12	32	95	HSK-A-80
HSK80A29124	16	34	95	HSK-A-80
HSK80A29125	20	42	95	HSK-A-80
HSK80A29126	25	53	95	HSK-A-80
HSK80A29127	32	53	120	HSK-A-80
HSK80A29321	1/4"	22	70	HSK-A-80
HSK80A29322	3/8"	35	70	HSK-A-80
HSK80A29323	1/2"	42	70	HSK-A-80
HSK80A29324	3/4"	52	95	HSK-A-80
HSK80A29325	1"	65	120	HSK-A-80
HSK100A29120	6	27	85	HSK-A-100
HSK100A29121	8	28	95	HSK-A-100
HSK100A29122	10	32	90	HSK-A-100
HSK100A29123	12	32	95	HSK-A-100
HSK100A29124	16	34	95	HSK-A-100
HSK100A29125	20	42	95	HSK-A-100
HSK100A29126	25	53	95	HSK-A-100
HSK100A29127	32	53	95	HSK-A-100
HSK100A29321	1/4"	22	95	HSK-A-100
HSK100A29322	3/8"	35	95	HSK-A-100
HSK100A29323	1/2"	42	95	HSK-A-100
HSK100A29324	3/4"	52	95	HSK-A-100
HSK100A29325	1"	65	120	HSK-A-100

Special items provided on request