



CONSTITUTION, RULES AND SPECIFICATIONS
of the
INTERNATIONAL SHARK CLASS ASSOCIATION



<u>Contents</u>	<u>Pages</u>	<u>Date of Issue</u>
CONSTITUTION	3 - 9	April 2010
APPENDIX I Championship Rules	10 - 13	April 2010
APPENDIX II General Class Rules and Specifications	14 - 29	April 2010
APPENDIX III Official Drawings	30 - 31	April 2010
APPENDIX IV	32 - 33	April 2010

REVISIONS

REVISION	DATE OF REVISION	DESCRIPTION
#0	May 15, 1977	As ratified at ISCA General Meeting, August 1976, Buffalo Canoe Club.
#1	July 15, 1979	Lack of quorum - not approved.
#2	April 15, 1982	Approved by mail vote.
#3	June 17, 1984	Approved by mail vote.
#4	March 10, 1988	Approved by mail vote.
#5	April 1, 1992	Rudder and Internal Halyards
#6	June, 1993	150% Genoa and Roller Furling
#7	May, 1995	North American Boat Weight and Foresail Luff
#8	April, 2010	Approved by mail vote of membership
#9	May, 2011	Advertising 9.12 (approved by vote of membership)
#10	May, 2011	Clarifications approved by ISCA Committee: Appendix II: 7.5 Dyform Rigging, 8.2h Mainsail
#11	September, 2013	Clarifications approved by ISCA Committee: Appendix 1: 7a,b,c. Appendix II: 3.3, 6.9a, 7.6a, 9.5b,c,d. Appendix IV: 7.20.
#12	August 2019	Appendix I 3a, 5a and 7 Appendix II 7.20 and 8.2(f)



CONSTITUTION

of the

INTERNATIONAL SHARK CLASS ASSOCIATION

1. TITLE

The full title of the Association shall be the “INTERNATIONAL SHARK CLASS ASSOCIATION” (ISCA).

2. EMBLEM

The emblem shall be the Shark Symbol as shown on the Shark Sail Plan.

3. PURPOSE

The purpose of the Association is to promote and further the interest of the Shark Class throughout the world by:

- a) maintaining the one-design character of the SHARK 24,
- b) coordinating and managing the affairs and rules of the Class,
- c) making recommendations on the control of the licensed builders,
- d) encouraging and coordinating both national and international competition and cruising in the Class,
- e) providing relevant information to members of the Class associations.

4. TERMS AND DEFINITIONS

Throughout these rules the following defined terms will be used:

- a) The “Association” shall mean the INTERNATIONAL SHARK CLASS ASSOCIATION (ISCA).
- b) A “National Association” shall mean a Shark Class National Association.
- c) The “National Authority” shall mean the officially recognized authority controlling and organizing the sport of yachting and sailing on a national basis in any country.
- d) The “Committee” shall mean the committee of the “Association”, consisting of duly elected or appointed Members,
- e) The “Association Rules” shall mean the rules governing the conduct of the Association.
- f) The “Association Register” shall mean the Register of members of the Association to be kept hereinafter provided.
- g) The “Class” shall mean the class of sailing yacht designed by George Hinterhoeller and made in accordance with his drawings and specifications, and known under the name “SHARK 24”.
- h) The “Class Rules” shall mean the rules relating to measurement, construction, specifications and racing, forming the appendices to the Association Rules and governing the building of each SHARK 24 and its listing as a recognized boat within the class for class racing purposes.
- i) The “Class Register” shall mean the tabulation of SHARK 24’s and their owners to be kept as hereinafter provided.



- j) The “Register of Molds” shall mean the Register officially measured, approved and numbered molds and keel patterns, from which the production of GRP constructed SHARK 24’s is approved by ISCA.
- k) The “Register of Builders” shall mean the identified Builders who have applied to the Association or the Copyright Holder for approval as constructors of SHARK 24 hull, deck and component molding in GRP, and have been granted such approval by the official approved and numbered molds for the construction of GRP SHARK 24’s and keels for SHARK 24’s.
- l) The “Registered Number” shall mean the “Sail Number allocated to the boat.
- m) The “Measurement Certificate” shall mean a certificate to be issued, ratified and endorsed as hereinafter provided and recording:
 - i) The Registered Number and Ownership of a SHARK 24 with its net weight recorded.
 - ii) The fact that such SHARK 24 originally complied with the Class Rules on completion of construction, together with such particulars as may be required by the Class Rules.
- n) A “Valid Measurement Certificate” shall mean:
 - i) The particulars of ownership are up-to-date and entered on the Class Register.
 - ii) Any endorsement required by the Class Rules has been duly entered.
- o) “Fleet” shall mean five or more registered SHARK 24’s normally located sufficiently near to each other to permit regular racing between them or cooperation in cruising matters.
- p) “Owner” and “Joint Owner” shall mean any person or persons, corporation or association entered on a certificate as owner or joint owner of a SHARK 24.
- q) “Copyright Holder” shall mean the person or persons or corporation for the time being in possession of the copyright in the drawings and specifications of the SHARK 24 yacht.
- r) “Licensee” shall mean the person, persons or corporation for the time being holding a license under the copyright of the SHARK 24 yacht for the construction thereof.

5. MEMBERSHIP AND VOTING RIGHTS

- a) The following classes of membership shall be recognized:
 - i) Full Member
 - ii) Associate Member
 - iii) Honorary Member
- b) A “Full Member” shall, subject to payment of the prescribed annual subscription by a National Association, be open to membership in the National Association or, in a country without a National Association, be an individual Owner (which is extended to immediate family such as spouse and/or children) of a SHARK 24 or, in the case of Joint Owners, to any one of them, or in the case of a SHARK 24 owned by a corporation or an Association to a nominated representative of that organization.
- c) An “Associate Member” shall, upon payment of the prescribed annual subscription to a National Association, be open to Associate Membership in a National Association, and in an individual or club interested in the Shark Class.
- d) An “Honorary Member” shall be any person having an interest in the Association or in the Class who is proposed by a Full Member and seconded by at least one member of that Committee and is elected by members of the Association at any General Meeting of the Association.
- e) Members shall be bound by the Association Rules.
- f) Members acting as helmsmen, entering SHARK 24’s in races, shall be bound by the Class Rules.



- g) Each Full or Honorary Member shall be entitled to one vote at a General Meeting of the Association, a postal ballot or a vote conducted by means of electronic communication in such a manner as may reasonably be expected to ensure the integrity of the voting system. Associate Members shall be entitled to attend and speak at any General Meeting, but not to vote.
- h) Members may be suspended for a period of up to one year, by the Committee for gross violation of the Class Rules or unsportsmanlike conduct or, after, due warning, for willful and persistent disregard of the rulings. Provided that on a vote of 75% of the members present at the AGM of such members national association the suspension may be extended or the Member permanently expelled.

6. THE OFFICIAL LANGUAGE

The official language of the Association shall be English.

7. ANNUAL CONTRIBUTIONS FROM THE NATIONAL ASSOCIATES AND FEES

- a) The Association shall be financed by a general levy from National Associates by means of a percentage of each National Association's income from subscriptions, or, where there is no National Association, by means of individual fees. The percentage and individual fee shall be determined biannually by the Committee of the International Association and shall apply equally to all National Associations and individual Members.
- b) The annual contribution from National Associations and individual Members shall become due on the First of June.
- c) Any National Association or individual Member who has not paid the annual contribution within two months of the due date may cease to be officially recognized by the Association and lose the privileges and benefits of membership of the Association under these rules, but may be restored to the list of officially recognized National Associations and individual Members at the discretion of the Committee and payment of any subscriptions due.
- d) The Association shall receive a fee of \$100.00 payable by each registered Builder, on each set of molds purchased. This fee is to be stated as a separate item on any quotation, estimate, invoice or statement relating to the cost of molds.
- e) The Association shall receive a building fee of 30% of the designer's Royalty for every SHARK 24 built. This fee shall be paid by the Builder not later than 60 days after the sale of the boat. In return, the ISCA shall:
 - i) Maintain control of the shipyards building the SHARK in order to ensure the provision of high quality class yachts.
 - ii) Invoice the royalty against the assignment of the Registered Numbers.
- f) Honorary Members are exempt from any contributions or fees.

8. MANAGEMENT

- a) The affairs of the Association shall be managed by the Committee.
- b) The Committee shall be comprised as follows:
The National Presidents (or duly appointed delegate) from each nation with twelve or more Full Members, each of who will be a full voting member of the Committee.



The National Presidents will appoint the President of the International Shark Class Association as well as the Specifications Officer of the International Shark Class Association, each of who will be full voting members of the Committee.

The ISCA President will seek out and recommend to the Committee for approval both a Class Honourary Treasurer and a Class Secretary.

The ISCA Specifications Officer will seek out and recommend to the Committee for approval Specifications Officers for each of North America and Europe.

Neither the Honourary Treasurer, Secretary nor European/North American Specifications Officers will be voting members of the Committee.

- c) No Member shall serve on the Committee as an appointed, elected or national committee member for more than three years, at the end of which period he shall retire, but shall be eligible for re-election after an interval of one year and may be co-opted. This provision shall apply only when a replacement Member is prepared to serve on the Committee.
- d) The Committee need not fill a vacancy arising in the Committee unless the total number of committee members has dropped below the minimum of six. Committee members appointed to fill a vacancy shall remain in office until the next General Meeting.
- e) At its first meeting to be held immediately after the General Meeting of the Association, the Committee shall:
 - i) Elect one of its members to act as President of the Association and one Vice-President who shall be in charge when the President is not available. They shall be elected for one year.
 - ii) Elect an Honorary Secretary or appoint a Secretary who shall keep correct minutes and records of all Committee and General Meetings, together with the Association Register and the Class Register and shall be responsible for communicating the decisions of the Committee to the members of the Committee and to National Associations and, where directed by the Committee, to SHARK 24 owners and other interested individuals or groups.
 - iii) Elect an Honorary Treasurer who shall have charge of the funds of the Association; make such disbursements as the committee shall direct; keep an accurate record of the financial affairs of the Association; and present an annual financial statement at each Annual General Meeting. The Secretary or the Honorary Secretary may fulfill the function of the Treasurer.
 - iv) Appoint an Auditor who shall certify the annual financial statement.
 - v) Elect a rules and technical subcommittee which shall be responsible for advising the Committee and the Association Members upon the interpretation to the Association Rules, for considering requirements for amendments or additions to such rules or to the Class Rules and for making recommendations to the Committee.
 - vi) Decide the time and place for the next meeting of the Committee and direct the Honorary Secretary to send notice of this meeting to all members of the Committee.
- f) At meetings of the Committee, five of the elected Members present shall form a quorum.
- g) The Committee shall have the power to make recommendations to the Members at a General Meeting, by post or by means of electronic communication in such a manner as may reasonably be expected to be received by such Member for alterations in or additions to the Association Rules.
- h) The Committee shall be responsible for the appointment of official class measurers and for the compilation and distribution of measurement forms, provided that no responsibility shall rest with the Committee in respect of errors made by measurers.
- i) The Committee shall arrange an annual World Championship of the Class and coordinate such national and regional championships as may be required and all matters pertaining



- to international championships shall be settled by the Committee in consultation with the sponsoring club or clubs and/or the relevant national authority.
- j) Owing to the difficulties of attendance at meetings of an international committee, at least eight weeks notice of the date, place and agenda for any such meeting must be given in writing by the Secretary to each Committee member. Business will mainly be conducted by correspondence, which shall always be circulated through the Secretariat. Any Committee member not answering a motion communicated to him in writing within six weeks of the date of mailing or sending of electronic communication, shall be deemed to have agreed to such motion. All communications to countries outside that of the Secretariat shall be sent by mail or by means of electronic communication in such a manner as may reasonably be expected to be received by such Member.
 - k) Acceptance of a certificate by Owner or Joint Owner shall ipso facto render him subject to the jurisdiction of the Association or the Committee in any matter pertaining to Class Rules.
 - l) A member of the Committee may be removed from the Committee for willful and unjustifiable act of commission or omission detrimental to the Association, the Class or any of its respective Members. Such removal shall be by a vote of not less than 75% of the remaining members of the Committee.

9. POWERS OF THE COMMITTEE

Subject to the provisions of these rules and in particular to the purpose of the Association as expressed in Rule 3, the General Committee shall be empowered to perform all functions of management and administration. The making of payments and receipt of monies shall be validly evidenced only by the signature of the Treasurer or his deputy as appointed by the Committee and payments or receipts of monies exceeding the sum of \$200.00 shall require the signature of the President and Secretary or Treasurer.

10. CONDUCT OF MEETINGS OF THE ASSOCIATION

- a) The Annual General Meeting of the Association shall be held each year at the World Championships or other major regatta of the Class, or any other place judged by the Committee to be the most convenient to the majority of Members of the Association, the precise date, time and place being at the Committee's discretion.
- b) A Special General Meeting shall be called by the President or Class Secretary upon receipt by the Class Secretary of a request in writing signed by not fewer than fifty Full Members of the Association.
- c) At least 60 days notice, in writing, delivered by mail, or by means of electronic communication in such a manner as may reasonably be expected to be received by such Member, shall be given to the Members of any General Meeting.
- d) At any General Meeting or Committee Meeting decisions, other than those concerned with the Constitution of the ISCA and/or its appendices, including the Measurement Rules, shall be carried by a majority vote. Voting shall be a show of hands unless a poll is demanded by not fewer than three of the Full Members present. At any meeting, the President shall have a casting vote. The Secretariat shall be responsible for circulating all National Associations or, in case of Committee Meetings, all committee members, with the result. In lieu of voting at a meeting, voting may take place by way of a postal ballot or by means of electronic communication in such a manner as may reasonably be expected to ensure the integrity of the voting system. All returns shall be made to the



Secretariat within four weeks of the date of posting of the ballot paper. In the case of an electronic vote, Members shall have a period of at least 4 weeks to cast a vote.

- e) At any General Meeting of the Association, fifteen Full Members shall form a quorum.
- f) At any General Meeting of the Association, a decision to make a change in or addition to the Constitution of the ISCA and/or its appendices, including the Class Rules, shall require a majority of two-thirds, all Members having been informed of the proposed change and its implications at least sixty days before the meeting. Any such change or addition shall require ratification by the Committee, which shall be presumed to be given unless otherwise announced within three months of the date of the General Meeting.

11. ACCOUNTS

- a) The committee shall cause true accounts to be kept giving full particulars of:
 - i) All monies, assets and liabilities of the Association.
 - ii) All monies received and expended by the Association and of the matters in respect of which such receipts and expenditure arise.
 - iii) All sales and purchases of goods by the Association.
- b) The Committee shall cause to be prepared and laid before the Members at every annual General Meeting of the Association an annual financial statement.
- c) A copy of the annual financial statement, duly audited, which is to be laid before the Members in General Meeting, shall not less than thirty days previous to such General Meeting be sent to every National Association.

12. PROTECTION OF “ONE-DESIGN” AND ISSUE OF CERTIFICATES

- a) The “one-design” character of the SHARK 24 throughout the world and the quality of these yachts shall be controlled by limiting building rights to selected builders in each country from which application is made to the Class Association or to the Copyright Holder. The number of builders may vary in each country, but where a territory is adequately served by one builder, another will not normally be granted rights to build or obtain molds for GRP construction. Licenses to build shall be reviewed annually and may be withdrawn. All applications for licenses to build shall be sent to the Association, which will refer these to the National Authority of the country concerned, asking such Authority to advise on the most suitable of these builders, whose premises and production facilities shall then be inspected by the Copyright Holder and a representative of the Association. The inspection shall be at the builders' own expense. If this inspection is satisfactory and approval is given by the Copyright Holder and the Association, the Copyright Holder shall be requested to issue a license to the builder, under the terms agreed between the Association and the Copyright Holder, to produce SHARK 24”S conforming with the official plans, specifications and measurement rules.
- b) No yacht shall be entered on the Class Register as a SHARK 24, or be eligible for a Certificate as a SHARK 24 unless the hull, deck and other component moldings, are produced by a builder approved by the Association and the Copyright Holder and entered on the Association Register of Builders.
- c) No yacht built of GRP shall be entered in the Class Register as a SHARK 24 or be eligible for a Certificate as a SHARK 24 unless built to the official plans and specifications from component moldings produced on officially measured, approved and numbered molds, issued on the authority of Copyright Holder and the Association and entered on the Register of Molds.



- d) The Association shall collaborate with the Copyright Holder and National Authorities in the allotment and issue of serial class numbers for SHARK 24's as they are built, and in the keeping of the Class Register, Register of Builders and Register of Molds.
- e) Measurement Certificates shall be obtainable from the National Yachting Authority, which may delegate its authority to the National Association, upon production of a measurement form properly completed by a national measurer or an official class or club measurer, showing the boat to be within the requirements of the Shark Measurement Rules.
- f) Measurement Certificates shall remain valid only so long as the boat continues to comply with the Measurement Rules.
- g) Only sails with the official ISCA label will be considered legal. Sail labels are to be purchased from ISCA. The manufacturer of the sails shall certify each sail complies with the specifications with said label. ISCA and National Associations reserve the right to measure any sail at any time and may restrict a manufacturer from purchasing labels if its sails are found not to comply with the Class specifications. Labels are non transferable from one sail to another.
- h) The responsibility for ensuring the validity of Certificates issued in respect of newly built boats shall rest with the Builder.
- i) The responsibility for ensuring the continuing validity of Measurement Certificates shall rest with the Owner. When ownership changes it shall be the responsibility of the new Owner to have the necessary endorsement completed upon his Certificate or to have the Certificate re-issued, as appropriate in the country issuing the Certificate.

END OF CONSTITUTION



CHAMPIONSHIP RULES

1. GENERAL

The International Shark Class Association has the overall responsibility for organizing World Championships and Continental Championships in cooperation with National Shark Class Associations and the National Yachting Authorities of different countries. These sailing events will be held under the following general rules:

2. CONDITIONS

All championship races will be sailed under the current ISAF (International Sailing Association Federation) Rules, including all amendments made by the local National Authority, and the rules of the International Shark Class and International Shark Class Association, except where specially amended in the Sailing Instructions.

3. FREQUENCY OF CHAMPIONSHIPS

- a) The World Championships may take place each year.
- b) The Continental Championship may take place every year but shall not be sailed at the same time and place as the World Championships if that event is held on the continent concerned.

4. SIZE OF CHAMPIONSHIP FLEET

- a) At World Championships, notwithstanding any entry restrictions or qualifications, a minimum of four boats per country and the preceding World Champion shall be automatically permitted to compete. The ISCA Committee may, at its own discretion, increase the basic allocation of competitors from any country.
- b) The allocation of boats from the country acting as championship host may be doubled.
- c) At Continental Championships, the number of boats admitted to the championship will be unlimited unless a limitation is specially imposed by the ISCA Committee.

5. QUALIFICATIONS FOR REPRESENTATION

- a) A representative of a country competing in the World Championships shall
 - (i) be a national or ordinarily resident of that country;
 - (ii) be a bona fide member of a yacht club of that country; and
 - (iii) meet World Sailing eligibility conditions.
- b) Helmsmen or skippers in World, Continental and National Championships shall be full members of the ISCA.

6. ELIGIBILITY OF BOATS FOR CHAMPIONSHIP REGATTAS

All boats entered for World, Continental, National Championships or sanctioned regattas must be in compliance with the rules and regulations of the International Shark Class and must have a valid measurement certificate. The Measurement Committee has the right to have all boats or sails, etc., wholly or partially re-measured. If deviations from the rules are found, the boat will not have the right to participate in SHARK 24 races until after further official measurement is completed to the satisfaction of the Specifications Committee.

7. NUMBER OF RACES IN CHAMPIONSHIPS

- a) At World Championships:
 - i) The number of races to be sailed shall be a minimum of four (4) to maximum of ten (10).



- ii) Four races shall constitute a Championship.
- iii) A distance race shall be scheduled to be run once four or more course races are completed provided that the distance race shall not be sailed on the last scheduled day of racing.
- iv) A maximum of three (3) races may be sailed in any one day and no course racing shall be held on the same day as the distance race.
- b) At Continental Championships, the number of races to be sailed shall be not less than four (4).
- c) At National Championships, the number of races to be sailed shall be shall be four, but the National Association or the National Authority may reduce this number at its own discretion.

8. SCORING SYSTEM

- a) At World Championships, the low point scoring system shall be used. Each entrant shall exclude any one race which may include the long distance race, from his final score, except that when only four races are completed, all shall count. If fewer than four races are completed, the championship shall be null and void.
- b) At Continental Championships:
 - (i) the number of races scheduled shall not be less than four (4);
 - (ii) here (3) races shall constitute a championship; and
 - (iii) a maximum of four (4) races may be sailed in any one day.
- c) At National Championships the scoring system is at the discretion of the National Shark Association or national authority concerned but it is recommended that the low point scoring system be used.

9. COURSES

- a) At the discretion of both the organizing and ISCA Committee, the courses may be windward leeward with a turning mark and leeward gate, a conventional Olympic type triangle or such other course configuration as may be commonly used for ISAF World Championships.
- b) As stated one of the races in the World Championships shall be a distance race. The length of this race is recommended to be not less than 24 kms and no more than 42 kms. It is also recommended that the distance race start with a windward leg of minimum 1.6 kms.
- c) At Continental Championships the course shall be at the discretion of the organizing authority,

10. SHORTENING OF COURSE

- a) At World Championships, the course may be shortened at the discretion of the race officer under ISAF Part 3 if he considers the full course cannot be completed in about one and one-half hours. Any race in which less than 3 legs of the course are completed shall be null and void. The above rule is not valid for the long distance race, which cannot be shortened. The long distance race shall be null and void if the leading boat cannot complete the course with a minimum average speed of two knots.
- b) At Continental Championships the course may be shortened at the discretion of the race officer under ISAF Part 3 if he considers that the full course cannot be completed in a reasonable period of time. Any race in which less than three legs of the course are completed shall be null and void.



11. STARTING LINES

At World Championships and at Continental Championships the starting line must be laid at approximate right angles to the first leg of the course. At the time of the first preparatory signal the first leg of the course shall be as near as possible to windward.

12. LENGTH OF STARTING LINE

At World Championships and at Continental Championships the starting line shall not be less than the total length of all boats entered, plus 25%.

13. MANAGEMENT

The management of both World and Continental Championships shall be divided as under:

- a) The host National Association will select, sufficiently in advance, a suitable Yacht Club at which to hold the event, with the agreement of the ISCA Committee.
- b) The organizing Committee shall be appointed by the Yacht Club or Yachting Association entrusted by the Host Association with the event. It must include at least one officer of the Host Association. The Organizing committee is responsible for the general management of the Championships, including safety measures, and under the jurisdiction of these rules. The Organizing Committee shall submit Preliminary Notices for the approval of the ISCA Committee at least 6 months before the Championships. The contents of these Notices shall be in accordance with Part 7, Race Organization and Appendix M, Notice of Race and Sailing Instructions of the ISAF Rules. The Organizing Committee shall submit the Sailing Instructions and Final Notice for approval of the ISCA Committee at least three months before the Championships. The contents of these notices shall be in accordance with ISAF Rules. The official language of the Sailing Instructions shall be English. It is desirable that translations into the language of the competing helmsmen shall be provided, but if this is not done, Sailing Instructions should be provided to all competing Helmsmen at least four weeks prior to the event so that they can make their own translations. It is the intention that all decisions concerning measurements, protests and these rules shall be final. The Organizing Committee shall therefore, obtain specific approval from its National Yachting Authority for the decisions of the Measurement, Protest and Class Committees to be final. After the Championships it shall submit a report to the ISCA Committee on the operating of the Championship Rules and any recommendations for their improvement.
- c) The Race Committee has the authority and duties as laid down in Part 3 of the ISAF Rules. The Race Committee shall be appointed by the Organizing Committee. The Race Committee should discourage all attempts towards team racing.
- d) The Class Committee shall represent the ISCA at the Championships. Each competing country which is eligible for representation on the ISCA Committee shall appoint a Class Committee Member, who shall be a full member of the ISCA and preferably a member of the ISCA Committee. The Chairman of the Class Committee shall be an International Shark Class Officer appointed by the ISCA Committee and preferably shall be the President of the ISCA Committee. The names of the Class Committee Officers will be given to the Organizing Committee by the ISCA Committee. The Chairman of the Class Committee shall co-operate with the Host Association and the Organizing Committee to ensure that an Official Class Measurer is available during the whole of the event, with adequate measuring equipment. Class Committee members shall decide on all matters concerning the interpretation of the Championship and Class Rules, the English edition of which will prevail in case of ambiguity. The Class Committee shall, in conjunction with the Organizing Committee, be responsible for establishing the order of the competitors at the end of the Championships and its decision shall be final. It shall ensure that these results are announced officially.



- e) The Measurement Committee shall be appointed by the Specifications Committee. It shall include an Official Class Measurer with adequate measuring equipment. The Measurement Committee shall submit to the ISCA Committee a report of its official activities, and any deviations from the Class Rules which it found.
- f) The Protest Committee (Jury). The Chairman of the Protest Committee(s) and Protest Committee(s) members shall be chosen by the Organizing Committee with the approval of the Class Committee. The Protest Committee officers shall be persons fully conversant with the ISAF Racing Rules of Sailing and their attitudes and judgments shall not be that of interested parties. It is suggested that the Protest Committee includes a representative of the National Yachting Authority of the Host country and follows the general procedures as outlined in the ISAF Racing Rules of Sailing.

14. PRIZES

In all Championship races it is recommended prizes shall be awarded to helmsman and crew of the first ten competing boats, with a minimum of prizes for five boats. The prizes shall be given for final points. It is also suggested that the Host Club or Association shall present a souvenir to all participants in the World Championships.

ISCA will present the Bill Metzger Trophy to the boat with the best score consisting of the practice race, the long distance race and the last course race.

END OF CHAMPIONSHIP RULES



APPENDIX II

GENERAL CLASS RULES AND SPECIFICATIONS

1. GENERAL

1.1

- a) The object of these Rules is to maintain the SHARK 24 as a one-design Class yacht. The Rules shall be interpreted so that racing as a Class shall emphasize the performance of crews over that of yachts.
- b) These Rules do not apply to SHARK 24's racing in open handicap events except where the rating assigned to the yacht is based on such yacht complying with these rules.

1.2

- a) The Rules and Specifications refer to the SHARK 24 plans, tables of offsets (lines) and fibreglass layups. These drawings and specifications are in the custody of the Chairman, Specification Committee, International Shark Class Association (ISCA) and form the basis of the standards for the areas covered.
- b) The offset drawings, Layup Specifications and other basic construction data are the property of the ISCA and may not be reproduced without the written permission of the ISCA.

1.3

- a) The Class Rules are obligatory.
- b) A boat, spars sails or equipment may be checked by a Class Measurer or any member of the ISCA or National Shark Class Association (NSCA) Specifications Committee at any time.

1.4

The ISCA Specifications Committee may under special circumstances and with the prior approval of the ISCA Committee:

- a) issue amendments and interpretations of these Rules under Appendix IV.
- b) grant dispensation for infringement of the Rules.

1.5

The official language of the Class Rules shall be English. In the event of any disputes over interpretation the English text shall prevail.

1.6

The weight and dimensions applying shall be those given in metric.

1.7

The ISCA, NSCA's and the Designer accept no responsibility in respect to these Rules or any claim arising there from.

2. BUILDERS AND OWNERS

2.1

Builders of the 'Shark 24' shall only be those holding a license issued by and under agreement with ISCA.



- 2.2
- a) Builders shall be responsible for supplying boats, sails, spars and equipment that comply with the International Shark 24 Rules.
 - b) The builder shall at his expense, correct or replace any boat or hull, sails, spar or other equipment supplied by him that fails to pass measurement.
- 2.3 Builders and owners shall consult with ISCA and obtain written authorization before making any changes in construction of the boat, spars or equipment as covered by these Rules.
- 2.4 The Rules shall be interpreted in a manner such that unless a change or modification from the boats original set up is specifically permitted by these rules, it shall not be permitted unless the Specifications Committee has given prior approval to such change.
3. REGISTRATION
- 3.1 ISCA shall maintain a sail number register and shall allocate sail numbers to registered builders.
- 3.2 Each hull manufactured by a registered builder shall have a registration plaque attached to the forward face of the aft cockpit bulkhead. The plaque shall provide the manufacturer's name, year of manufacture, sail number and serial number.
- 3.3 In boats whose registration plaque is missing, replacement plaques can be obtained from ISCA using the serial number stamped into the transom as a reference.
- 3.4 The registered sail number shall remain as identification of the hull regardless of ownership.
- 3.5 The ownership registration shall be made through the NSCA concerned.
4. MEASUREMENT
- 4.1 The Shark 24 is a one-design class. Measurement shall be carried out to these rules.
- 4.2
- a) Only recognized Class measurers as appointed and approved by each National Shark Class Association shall measure a boat, its spars, sails and equipment.
 - b) A measurer shall not measure a boat, spars, sails or equipment owned or part owned by himself.
- 4.3 Payment for the measuring fee, where applicable shall be the responsibility of the owner.
- 4.4
- a) All new boats, spars, sails and equipment shall comply with the current rules.
 - b) Old boats, spars, sails and equipment shall comply with either the current rules or the rules applying at the time of manufacture.
 - c) All alterations, replacements, restorations or modifications shall comply with the current rules.



5. CERTIFICATION

5.1

- a) An official Class measurement Certificate shall be issued by the NSCA concerned on receipt of a correctly completed official Measurement Form and payment of the appropriate NSCA measurement fee, if applicable
- b) The Measurement Form shall be retained by the NSCA.
- c) The Measurement Certificate shall be considered as valid only when:
 - i) a current membership fee receipt is attached and
 - ii) in North America only a current membership fee sticker is attached to the upper left hand corner of the transom.

5.2

- a) Change of ownership shall invalidate the Measurement Certificate, but shall not require re-measuring.
- b) The new owner shall apply to the NSCA for a new Certificate.

5.3 It shall be the responsibility of the owner to ensure that the boat, spars, sails and equipment comply with the Class Rules.

5.4 All replacements of spars and equipment (except sails) covered by these rules shall be submitted to measuring and be filed with the NSCA otherwise the Measurement Certificate will be invalidated.

5.5 The measurement certificate may be revoked by ISCA in the event the boat or equipment to which the Certificate relates is determined by the Specifications Committee to fail to comply with the Class Rules.

6. HULL, DECK, KEEL AND RUDDER

6.1 Hull

- a) All hulls shall be produced in molds taken from the master plug owned by the International Shark Class Association.
- b) The hull shall be constructed of fibreglass (glass cloth, chop, roving and reinforced mat plastic to conform with the Layup Specification (see 1.2). As well, the mat and roving weights and quantity of resin used are specified.
- c) Hull thickness and weights are governed by these standard layups.
- d) Neither sandwich construction nor any system which is intended to leave trapped air cells within the wetted skin shall be permitted.
- e) Overall dimensions of the Hull are as follows:
LOA: 7315 mm (24' 0") Beam: 2083 mm (6' 10")
- f) Designed waterline length and draft are as follows:
LWL: 6095 mm (20' 0") Draft: 965 mm (3' 2")

6.2 Deck

- a) The deck unit (cabin, lazarette covers(s), cockpit, etc.) shall be of molded fibreglass according to the Layup Specification.
- b) The deck and cabin top unit may be of "sandwich" or synthetic microballoon construction.



- c) The self-bailing feature of the cockpit shall be retained.
- d) Wooden cockpit coaming heights shall be no lower than that of the standard fibreglass molding. Boats with wooden coamings may alter the coamings to have the same profile as boats equipped with fibreglass coamings found in later model Sharks.
- e) Control lines (sheets, halyards, tensioning devices) shall not be led through the cockpit coaming, hull or deck. Where the original arrangement provided for genoa sheets to be led through the wooden coaming (single centre winch), this shall be considered to be acceptable.

6.3 Keel

- a) The keel shall be of cast iron which may contain not more than 2% nickel or other alloying ingredient. The keel weight shall be 306 kg \pm 7 kg (675 \pm 15 lb) for casting variations.
- b) The keel shall conform to the dimensions shown in Appendix III, Fig. 1.
- c) The thickness of the keel web or flat section at the fore and aft points shall not be greater than 22 mm (7/8") or less than 16 mm (5/8"). The thickness must be constant over the length of this section within 6 mm (1/4") i.e. max. allowed thickness at any point of this section is 28 mm (1 1/8"). The leading and trailing edge can be tapered to a maximum of 50 mm measured perpendicular to the casting.
- d) The keel shall be positioned with the trailing edge of the flange located 3295 mm (10' 9-3/4") minimum to 3325 mm (10' 11") maximum from the transom measured along the hull at the centerline. The distance from the 'aftermost point of the keel-shoe to the lowest point of the transom at the centre line shall be 2845 mm \pm 20mm (112" \pm 3/4"). The distance from the same point on the keel to the nearest position on the centre line of the hull shall be 670 mm \pm 15 mm (26 1/2" \pm 5/8").
- e) The keel flange shall extend below the hull surface a minimum of 12 mm (1/2") along its entire length to be measured 25 mm (1.0") in from the edge of the flange at the hull surface and on the same angle as the hull surface.
- f) The fairing at the front and rear of the flange at the junction with the hull shall not exceed 150 mm (6.0") in length.
- g) The fairing at the hull and the vertical sides of the flange shall not be greater than 11 mm (7/16") concave radius with the radius being tangential to both the flange and hull surfaces.

6.4A Weight - Outside North America

- a) The weight is to include the following: hull, keel, rudder and tiller, 3 internal bunks and mattresses (see 9.3, a) for dimensions), shelving, lighting with battery, immovable internal equipment, mast, boom and all rigging, both standing and running. Not included are sails, motor, fuel and tank, tools, anchors with lines, or other movable items.
- b) This net weight is to be a minimum of 953 kg (2100 lb).
- c) If corrector weights are required to attain the Class minimum, these shall be in the form of metal plates or sheets, be permanently marked with the weight and shall be fastened in a permanent manner to the bunk tops.
- d) The corrector weight shall be indicated on the Measurement Certificate.



6.4B Weight - North America only

- a) BASIC BOAT WEIGHT shall be not less than 953 kg. (2100 lbs) when equipped as follows:
- Spars, standing and running rigging, excluding sheets and spinnaker pole
 - Floor boards.
 - Hatch boards
 - Rigid lazarette cover and motor cut out.
 - Rigid bunk tops including all cut-outs and inserts
 - Rudder and tiller
 - Removable Shelving
- b) All removable equipment such as floorboards etc. which is on board to determine this BASIC BOAT WEIGHT will be noted on the measurement form and identified in some manner by the measurer. Yachts will be weighed with all other removable equipment offloaded. Permanently installed equipment may be left in place but will be noted on the measurement form. Any such equipment which, in the opinion of the measurer, is installed solely to effect a more favorable weight distribution than corrector weights would allow shall be removed or subtracted from the BASIC BOAT WEIGHT.
- c) If corrector weights are required to attain the BASIC BOAT WEIGHT, these shall be in the form of metal plates or sheets, be permanently marked with the weight and shall be fastened in a permanent manner to the topsides or undersides of the bunk tops.
- d) The corrector weight shall be indicated on the measurement certificate.
- e) ALL UP RACING WEIGHT shall be not less than 2300 lbs when equipped with all items included in the BASIC BOAT WEIGHT, all equipment specified in Rule 9 (Racing Regulations) and any optional equipment required to reach the ALL UP RACING WEIGHT. Personal clothing and consumable stores including water and engine fuel may not be included in the ALL UP RACING WEIGHT.
- f) The equipment added to the BASIC BOAT WEIGHT to arrive at the ALL UP RACING WEIGHT is to be normal racing and cruising equipment and not ballast.
- g) All equipment comprising the ALL UP RACING WEIGHT of the yacht shall be itemized on the Inventory of Required and Optional Equipment, which shall be carried aboard the yacht and be available for inspection by race authorities.
- h) Any owner whose officially measured BASIC BOAT WEIGHT is over 953 kg. (2100 lbs) may apply for WEIGHT RELIEF. This will be considered only:
- (i) when no BASIC BOAT WEIGHT corrector weights are being used.
 - (ii) to the extent by which the BASIC BOAT WEIGHT exceeds 953 kg. (2100 lbs).
- This application must be submitted in writing on the prescribed form to the local measurer who will consult with and get the approval of the Chief Measurer. If the Chief Measurer approves, he will certify and sign the application, produce a new measurement certificate and mail these to the owner.



WEIGHT RELIEF will be granted first of all to those items in group A in any order. When these are exhausted, items from group B may be requested in any order. When relief is granted they shall void the need to comply with the applicable section of Rule 9. Racing Regulations.

Group A

Reduce/remove bunk cutouts
Reduce/remove v-berth insert
Reduce number of/remove bunk cushions
Remove forward floorboard (if appropriate)
Install lighter floorboards (if appropriate)
Reduce size of/remove anchor
Reduce/remove internal shelving

Group B

Make Minor enlargements to bunk cutout holes
Make minor internal structural modifications e.g. removing built in cooler etc.
The Specifications Officer will have the discretion to consider other weight reduction methods including the reduction of motor corrector weights in certain cases of grossly overweight boats.

Appendix IV 1, (Section 23, Builders and Owners) shall not apply in North America

6.5 Rudder

- a) The Rudder shall be constructed of solid hardwood or alternately of fibre reinforced plastic over an optional core. The core must be suitable for the applied loads.
- b) The minimum weight including pintles or pins but less tiller and extension shall be 7.7 kg. (17 lbs.). A maximum of 0.9 kg of corrector weights may be added.
- c) The blade thickness shall be 40 mm \pm 5 mm (1-9/16" \pm 3/16"). This thickness is to comply for a minimum distance of 711 mm (2'4") below the transom.
- d) The depth of rudder below the lowest point of the transom shall be a minimum of 813 mm (2'8").
- e) The rudder width between the bottom of the transom and 711 mm (2'4") below the transom, shall not be more than 432 mm (17") and not less than 178 mm (7"). Also it must at some point be 279 mm (11") wide. The width below the 711 mm (2'4") point is unrestricted.
- f) Rudder blades shall be fixed relative to the pintles. Neither rudder depth nor rudder profile shall be adjustable. The line of the gudgeons may be set at the vertical.
- g) The rudder or transom shall be fitted with a suitable means of preventing the rudder from becoming detached from the hull.
- h) No other foils are allowed above or below the waterline, i.e. endplates, winglets.



6.6 Tiller

- a) The tiller shall be a maximum length of 1270mm (50") measured from the aft-most part of the transom to the forward-most part of the tiller extending into the cockpit, with the tiller properly installed to the rudder, and with the rudder hung in its normal position.
- b) There are no restrictions to the tiller extension length.

6.7 Chain Plates

- a) The upper and lower shrouds shall be attached to a common chainplate, which shall be bolted to the after side of the main bulkhead as close to the gunwale as possible.
- b) The backstay shall lead to a single chain plate on the port side of the tiller and shall not straddle the tiller.

6.8 Forestay Bow Fitting

- a) The centre of the forestay attachment hole at the bow fitting shall not be greater than 230 mm (9") from the foremost point of the hull (bow fitting extension excluded).
- b) Where the bow fitting provides more than one forestay attachment hole, the hole to be used shall be identified by a band having a minimum width of 6 mm ($\frac{1}{4}$ ") and painted in a contrasting colour forward of the hole.

6.9 Mast Step

- a) Shall be a metal alloy channel with a minimum length of 560 mm (22"), a minimum width of 90 mm (3- $\frac{1}{2}$ "), and a minimum height of 45 mm (1- $\frac{3}{4}$ "). The height may be tapered fore and aft from the mast butt position.
- b) Shall be mounted on top of the cabin.

6.10 Mainsheet Traveler Track

- a) Shall be mounted across the cockpit with its lower surface within 25 mm (1") of seat level.
- b) Situated 559 mm \pm 25 mm (22" \pm 1") measured at seat level from the aft end of the cockpit to the track centre.
- c) The thwart shall not be removed.

6.11 Compression Post

A compression post maybe used to support the deck and mast. The post shall be used in conjunction with any original bulkhead or frame. The post should not replace any original bulkheads, frames or equipment. The compression post cannot be adjustable after being installed. The sole purpose of the compression post is for additional support. The weight of the post will not be included in the basic boat weight. The post shall be placed in such a way that it should not impede the entrance to or exit from the forepeak.

7. SPARS AND RIGGING

7.1 Mast



- a) Mast shall be an aluminum spar section limited by the following weights and dimensions. The minimum weight of the section is 1.63 kg/m (1.1 lb/ft). It may not be tapered and its fore and aft and athwart ships minimum dimensions are 90.0 mm (3.5") and 50 mm (2") respectively. The wall thickness shall be uniform throughout the length of the spar.
- b) For Shark 24's built in North America the mast section shall comply with Appendix III, Fig. 2.
- c) The minimum weight of the mast with the following attachments shall not be less than 20.4 kg (45 lbs.).
 - Foot Casting
 - Boom gooseneck track (or equivalent)
 - Spinnaker pole track (or equivalent)
 - Jumper struts, wires and turnbuckles
 - Spreaders
 - Upper and lower shrouds plus turnbuckles
 - Forestay minus all removable mast fittings
 - Backstay minus all removable tensioning devices
 - Main, jib and spinnaker halyards including rope tails
 - Spinnaker pole topping lift and downhaul ropes and/or wires
 - Headsail tensioning device if so fitted
- d) The foot casting may be either of aluminum alloy or stainless steel.
- e) The mast shall not be allowed to rotate.
- f) Halyards and spinnaker pole up haul and downhaul control lines may be external or internal to the mast.

7.2 Mast Bands

- a) The mast shall carry two (2) painted bands in a colour contrasting with the mast.
- b) They shall be at least 25 mm (1") wide.
- c) The upper edge of lower mast band shall be 965 mm \pm 12 mm (38" \pm 1/2") above the elevation of the sheer. The points on the deck, outside the track, will be approximately 2500 mm (8' 2-3/8") from the bow when measured along the sheer. For masts with fixed goosenecks with the boom attached and at right angles to the mast, the top surface of the boom shall not be below the top of the lower mast band.
- d) The lower edge of the upper mast band shall be a maximum of 7010 mm (23' 0") above the upper edge of the lower mast band.

7.3 Spreaders

- a) Shall be of wood, aluminum or stainless steel of 16 mm (5/8") minimum diameter or equivalent cross-sectional area (measured at the base).
- b) Shall not be shorter than 585 mm (23") from the centre line of the shroud to the near side of the mast.
- c) The centerline of the spreaders at the mast shall be 2250 mm \pm 25 mm (7' 4-1/2" \pm 1") above the lower mast band.

7.4 Jumper Struts



- a) Shall be of wood, stainless steel or aluminum alloy of 12 mm (½”) minimum diameter, or equivalent cross sectional area (measured at the base).
- b) Shall not be shorter than 255 mm (10”) measured from the junction at the mast to the centerline of the jumper stay.
- c) The angle between the jumper struts and the fore and aft centerline of the mast shall be $50^{\circ} \pm 5^{\circ}$.
- d) The centerline of the V-struts (jumpers) at the mast shall be 5207 mm \pm 25 mm (17’ 1” \pm 1”) above the upper edge of the lower band on the mast.

7.5 Stays and Turnbuckles

- a) Stays and turnbuckles are to conform to the following:

	Wire Sizes (1x19) Minimum. Diameter	Turnbuckle Sizes Minimum
Forestay	3.0mm (1/8”)	NA
Upper Shrouds	4.0 mm (5/32”)	8.0 mm (5/16”)
Lower Shrouds	3.0 mm (1/8”)	6.0 mm (1/4”)
Back Stay	2.0 mm (3/32”)	NA
Jumper Stays	2.0 mm (3/32”)	5.0 mm (3/16”)

- b) When a roller furling system is installed as part of the forestay, the rating of the system shall not be less than 907 kg (2000 lbs).
- c) If the roller furling system utilizes a foil/ slotted forestay, the foil/slotted forestay must be restricted to a single luff groove.
- d) The use of Dyform or other non-standard 1x19 wire rigging is not permitted.

7.6 Standing Rigging

- a) Except backstays, shall be adjustable only by the normal use of standard turnbuckles. Adjustable turnbuckles are permitted, but must use threaded components.
- b) All attachment points on the mast for standing rigging must be external to the mast.

7.7 Lower Shrouds

The upper extension of the lower shrouds shall intersect the mast at a point no greater than 100 mm (4”) below the center line of the spreaders.

7.8 Upper Shrouds

The attachment point of the upper shrouds to the mast shall not be above the jumper strut centerline or be more than 150 mm (6”) below that point.

7.9 Forestay



The upper extension of the forestay shall intersect the mast at a point 5207 mm \pm 25 mm (17' 1" \pm 1") above the upper edge of the lower mast band.

7.10 Backstay

Minimum length shall be 7900 mm.

7.11 Jumper Stays

Jumpers shall be attached at the masthead fitting with the lower extension intersecting the mast at a point not greater than 100 mm (4") above the centreline of the spreaders.

7.12 Jib Halyard Block

The attachment point for the jib halyard block shall be not less than 76mm (3") below the point where the forestay intersects the mast.

7.13 Spinnaker Halyard Block

- a) The maximum height of the underside of the spinnaker halyard immediately forward of the block or lead shall be no greater than 5194 mm (17' ½") above the upper edge of the lower band.
- b) The maximum horizontal distance between the forward face of the mast and the forward side of the spinnaker halyard immediately below or above the block or lead shall be no greater than 76 mm (3").
- c) The measurement of rules 7.12 a) and 7.12 b) shall be taken with the halyard tail cleated on the mast, tied off at the mast exit sheave box or mast bottom turning block and with the spinnaker end of the halyard drawn horizontally forward of the mast.
- d) There shall be no other means of supporting or leading the halyard at the spinnaker end, other than the block or lead covered by rules 7.12 a) and 7.12 b).

7.14 Mast Foot Position

- a) Shall be 2235 mm (7'4") maximum from the leading edge of the mast immediately above the foot casting to the centre of the designated forestay attachment hole in the bow fitting. This measurement shall be taken parallel to the deck.
- b) The hole in the mast step used to establish the above measurement shall be clearly identified by a painted contrasting band not less than 6 mm (¼") wide, immediately aft of the designated hole.

7.15 Boom

Shall be of aluminum alloy of uniform cross-section, less all fittings, shall have a minimum weight of 3.4 kg (7.5 lbs.).

7.16 Boom Band

- a) The boom shall carry a single painted band in a colour contrasting the boom.
- b) The band shall be at least 25 mm (1") wide.



- c) With the boom attached to the gooseneck fitting and at right angles to the mast the distance between the downward projection of the aft edge of the mast, disregarding projection or cutouts, and the forward edge of the boom band shall be 3100 mm (10'2") maximum.

7.17 Boom Vangs

Boom Vangs, Boom Kickers, Boom Topping Lifts and Boom Preventers are permitted. Vangs shall be led to the fore and aft centerline of the yacht within 305 mm (12") of the aft side of the mast.

7.18 Spinnaker Pole

- a) When set at right angles to the mast and parallel to the centerline of the yacht, the measurement from the front of the mast, excluding the track, to the extreme outboard end of the pole including all fixed fittings shall not exceed 2235 mm (7'4").
- b) The inboard end of the pole may be raised or lowered at the mast by means of a track or by shifting between fixed points. The highest point of attachment shall not be greater than 813 mm (32") above the upper edge of the lower mast band.

7.19 Sheets

- a) Shall be led to points within the plan contours of the hull and no device may be used to sheet or lead sheets outboard of these contours, other than a spinnaker or whisker pole or as provided for in the ISAF Racing Rules of Sailing applying for foresails.
- b) The mainsheet shall be led within the cockpit.
- c) The foresail sheets shall be first led through fairlead blocks located outside the cockpit area.

7.20 Deck Layout

The deck layout for halyards, sheets, and other control line hardware is not restricted. The use of cleats, winches, or purchase systems is optional, except for what is described elsewhere within these Class Rules.

8. SAILS

8.1 General

- a) Sails shall be constructed only of woven fabric or woven cloth and are to conform to the measurements and specifications listed below. The use of Mylar, Kevlar or laminates using these materials are not allowed.
- b) Two "windows" are allowed in each sail. Total window area per sail is not to exceed 38096 sq. mm (600 sq. inches). The windows shall be transparent and section 8.1 a) shall not apply to material use in the window.
- c) All sails must bear an ISCA sail label.
- d) If there is discrepancy in the sail cloth weight, the manufacturer's published cloth weight will be used to establish the cloth weight. This applies to all Shark sails.



8.2 Mainsail

- a) Minimum sail cloth weight: 0.215 Kg/sq.m.
- b) Leach 7468 mm (24' 6") maximum
- c) Mid girth 1956 mm (6'5") maximum
- d) Three-Quarter-Height Girth 1143 mm (3'9") maximum
- e) Top Width maximum 120mm. Mainsails built 2016 or earlier may have top width maximum 140mm.
- f) Battens Top and Bottom (2) 610 mm (24") maximum
 Middle (1) 686 mm (27") maximum.
- g) Batten pockets shall be equally spaced along the after edge of the sail.
- h) The mainsail shall be affixed to the mast and boom by the bolt rope or slug and slot method. The minimum number of slugs required to affix the main to the slot on the boom is one.

8.3 Jib

- a) Minimum cloth weight 0.215 Kg/sq.m.
- b) Luff length 5486 mm (18' 0") minimum, 5918mm (19' 5") maximum
- c) Battens 2 (optional) 305 mm (12") maximum length
- d) Batten pockets shall be equally spaced along the leach.
- e) The width of this sail measured perpendicular to the luff shall not be greater than 2819 mm (9' 3").
- f) There shall be a minimum of six (6) piston hanks or equivalent when used with a wire forestay.
- g) When used with a roller furling head foil, the hanks shall not be required.

8.4 #1 Genoa

- a) Minimum cloth weight 0.156 Kg/sq m.
- b) Luff length 5486 mm (18'0") minimum, 5918mm (19' 5") maximum
- c) The width of this sail measured perpendicular to the luff shall be not less than 3912 mm (12' 10") and not more than 4013 mm (13' 2").



- d) The Sail shall have only one clew and the outside diameter of the clew ring shall not exceed 51 mm (2").
- e) There shall be a minimum of six (6) piston hanks or equivalent when used with a wire forestay.
- f) When used with a roller furling head foil, the hanks shall not be required.

8.5 #2 Genoa

- a) Minimum cloth weight 0.156 Kg/sq. m.
- b) Luff length 5486 mm (18'0") minimum, 5918mm (19' 5") maximum
- c) The width of this sail measured perpendicular to the luff shall be not less than 3302 mm (10' 10") and not more than 3404 mm (11' 2").
- d) The Sail shall have only one clew and the outside diameter of the clew ring shall not exceed 51 mm (2").
- e) There shall be a minimum of six (6) piston hanks or equivalent when used with a wire forestay.
- f) When used with a roller furling head foil, the hanks shall not be required.

8.6 Spinnaker

- a) Minimum cloth weight 0.034 Kg/sq.m.
- b) Luff or Leach 6147 mm (20'2") maximum
- c) Width 4013 mm (13'2") maximum
- d) The cloth shall be continuous, woven and without "peepholes" or venturi flaps.
- e) The spinnaker shall be symmetrical.

8.7 Sail Numbers

- a) Numbers are to be displayed on both sides of the mainsail and genoa and on the outside of the spinnaker.
- b) They shall be placed as laid down by ISAF Racing Rules of Sailing
- c) The numbers shall be of the following minimum dimensions:
 - Height 300 mm (12")
 - Width 200 mm (8")
 - Thickness 45 mm (1-3/4")
- d) The space between adjoining letter and numbers 60 mm (2-3/8")

8.8 National Letters



- a) National Letters (as described in ISAF Racing Rules of Sailing) are to be displayed on both sides of the mainsail for all World and International Events. National letters are not required for National Events or other sanctioned events.
- b) The National Letters shall be placed as laid down by ISAF Racing Rules of Sailing.
- c) The letters shall be of the following minimum dimensions:

Height	300 mm (12")
Width	200 mm (8")
Thickness	45 mm (1¾")
- d) The space between adjoining letter and numbers shall be 60 mm (2-3/8")

8.9 Emblem

- a) The "Shark" emblem shall be displayed above the sail number/letters on both sides of the mainsail.
- b) The outline of the emblem shall be as shown in Appendix III, Fig. 3.
- c) Minimum overall length shall be 812 mm (32").

9. RACING REGULATIONS

9.1 General

All racing between SHARK 24's as a one-design class shall be governed first by the ISCA Class Rules, second by the ISAF Classic Yacht Rules and third by the National Authority Rules in effect in the country in which the races are held.

9.2 Crew

- a) The minimum crew for ISCA and NSCA sponsored racing shall be three (3).
- b) Changes in crew during a series of races shall be made only with the approval of the Race Committee and/or Jury, and may be undertaken only due to illness or required absence for other unavoidable reasons.

9.3 Equipment Requirement

- a) All SHARK 24's shall carry the following while racing:
 - i) An anchor of minimum weight 5.5 kg (12 lbs) attached to a length of at least 30 meters (100') of 12.5 mm (½") manila line or 9.5 mm (3/8") Nylon, Polypropylene or equivalent.
 - ii) Two paddles or oars of minimum length 1220 mm (4').
 - iii) Three bunks, and three mattresses or sets of mattresses each totaling 1830 mm (6') minimum length and 610 mm (2') minimum width or equivalent area and having a minimum thickness of 50 mm (2") and made from foam completely covered with vinyl, cloth, or equivalent material.
 - iv) One ice box.
 - v) One approved lifejacket or approved personal flotation device for each member of the crew.
 - vi) Such other equipment as may be required by local law requirements.
 - vii) A completed form entitled Inventory of Required and Optional Equipment (North America only).



9.4 Motor and Fuel Tank – **North America Only**

- a) A motor plus fuel tank shall be stored in the lazarette at all times when racing.
- b) If the motor plus empty fuel tank weighs less than 27.2 kg (60 lbs) then corrector weights must be permanently attached to the bulkhead within the lazarette. The corrector weight shall carry a permanent mark indicating its weight. The corrector weight may be of metal, cement or similar dense solid material and shall not be an object of any utility use (such as an anchor, sounding lead, or tools).
- c) The corrector weights shall be indicated on the Measurement Certificate.

Motor and Fuel Tank – **Europe Only**

- d) When a motor is required by the regatta organizing committee or the appropriate authorities, it must be stowed in the cabin or the lazarette.
- e) If the motor and the empty fuel tank (in case of an electric motor including the battery) weigh less than 27.2 kg, a corrector weight must be carried. It must be marked permanently showing its weight. The corrector weight may be made of metal, concrete or a similar dense hard material. It may not be a regular utensil such as an anchor, a sounding lead or tools.
- f) The corrector weight must be stowed next to the motor.

9.5 Lazarette Cover

- a) The lazarette cover and transom hatch shall remain closed in their proper place during racing.

Lazarette Cover – **North America Only**

- b) The minimum weight of a replacement lazarette cover shall be 4.4 kg (9.7 lbs).
- c) The minimum weight of a replacement transom hatch shall be 0.68 kg (1.5 lbs).
- d) Corrector weights cannot be used to reach the minimum weight for section 9.5 b) and c).

9.6 Sails

- a) At no time in any race sailed under these Rules may a SHARK 24 carry on board more than 1 mainsail, 3 headsails and 2 spinnakers.
- b) On the advance written notice of the sponsoring body, the following optional rules may be adopted for a regatta, series or races or single race: "A yacht shall register (measure) for this event (series, regatta, race) a sail inventory not to exceed 1 mainsail, 3 headsails and 2 spinnakers. These sails shall be distinctively marked by the sponsoring body. Any yacht carrying on board any sail not so marked during any race shall be disqualified from that event."
- c) Unless permission is obtained from the Race Committee or Jury, only sails bearing the registered sail number of the yacht may be used.
- d) Roller furling devices are allowed. They may be used during racing but must not be used between the fully furled or open (unfurled) positions.
- e) All foresails must be flown with all hanks attached to the forestay and with the tack attached to the stem head fitting. Slotted furling systems are accepted.



9.7 Mast Foot

The position of the mast foot shall not be altered while racing.

9.8 Rudder

The rudder shall not be changed while racing or during a regatta or race series without permission of the Race Committee or Jury.

9.9 Mast and Boom Bands

While racing the head of the mainsail shall not extend above the bottom edge of the upper mast band, the clew of the mainsail shall not extend beyond the inside edge of the boom band and the top surface of the boom shall not extend below the top of the lower mast band.

9.10 Hiking Aids

No hiking device which extends beyond the gunwale for supporting crew, or counterbalance weights beyond the gunwale permitted. No hiking aid, other than standard equipment in its normal position (e.g., grab rails, shrouds, sheets in use for normal sail adjustments), is permitted.

9.11 Hand Rails

The cabin top hand rails (grab rails) shall not be moved from their original position but can be either lengthened or shortened to accommodate control lines. Cabin top hand rails cannot be removed in their entirety.

9.12 Advertising

Advertising on a boat (including hull, spars, sails and equipment) shall be prohibited while sailing in Class events, except for Event Advertising and Manufacturer's and Sailmaker's Marks (pursuant to the ISAF Advertising Code).

Competitor Advertising (pursuant to the ISAF Advertising Code) on Personal Equipment is permitted.

END OF GENERAL CLASS RULES AND SPECIFICATIONS

APPENDIX III

III - 1 Official Drawings

FIG. 1 Keel Dimensions

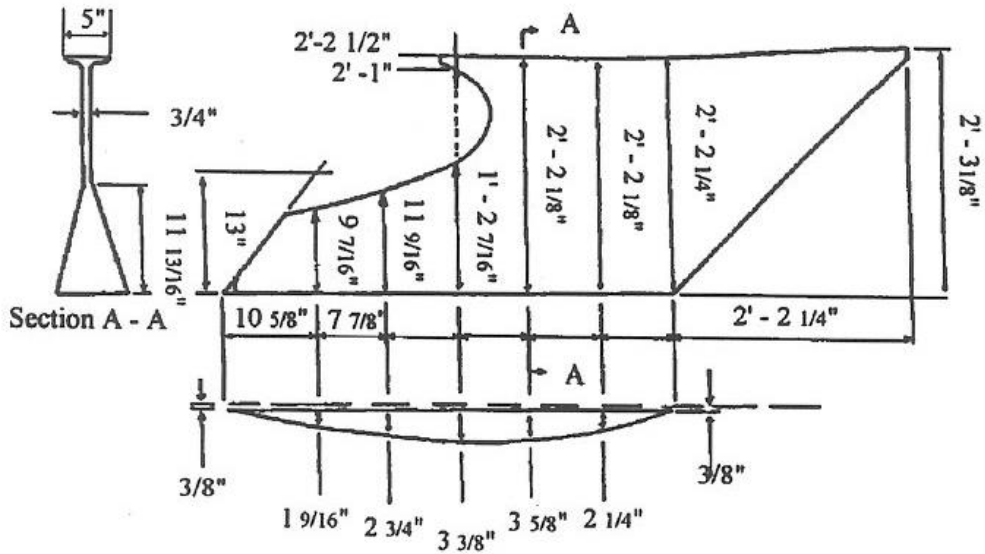

Dimensions shown are in feet and / or inches.

FIG. 2 North American Mast Section

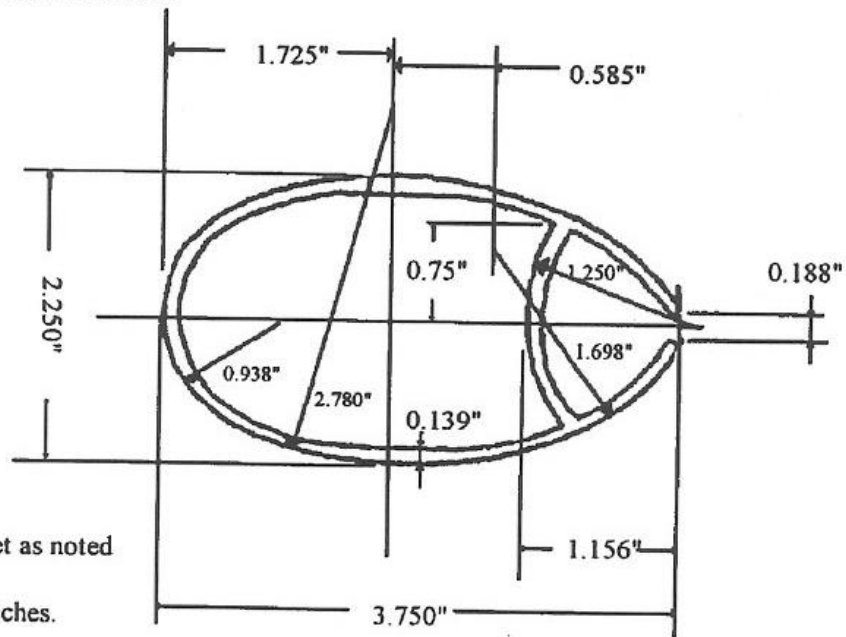

Wall thickness 0.100" except as noted
 Weight 1.38 Lbs per Ft.
 Dimensions shown are in inches.

Appendix III
III - 2

Fig. 3 Shark Emblem

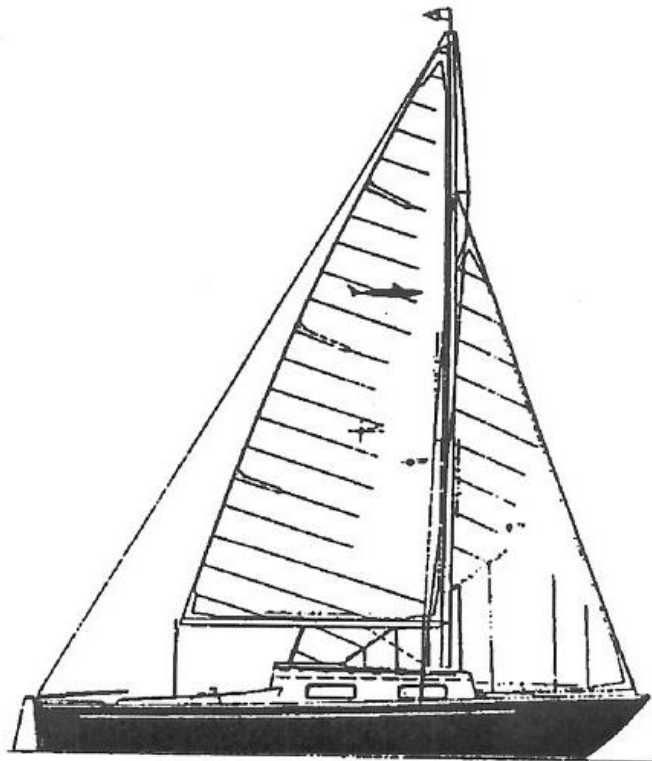
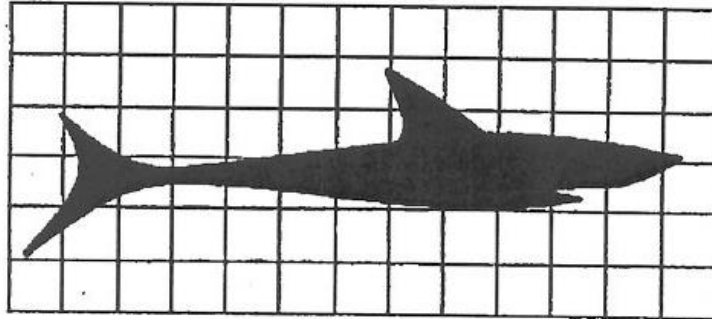



APPENDIX IV

INTERPRETATIONS AND EXEMPTIONS TO THE GENERAL CLASS RULES AND SPECIFICATIONS

1. **SECTION 2: BUILDERS AND OWNERS**

There is little scope or justification for the committee to grant specific interior modifications except for boats that are significantly overweight. When an application to modify is submitted, the committee will examine the recorded weight of the boat. As a guideline, if a boat is more than 2% over minimum weight, specific minor modifications will be permitted. These modifications are designed to have minimal effect on the appearance and function of the interior and are not permitted in conjunction with corrector weights.

Application Procedure

Any owner of a boat officially measured as over minimum regulation weight (2100 lbs.) by 2% or more, may apply for reduction approval. The procedure is as follows:

- 1) Owner submits application in writing to the National Measurer and ISCA Specifications Committee citing official weight.
- 2) Specifications Committee issues written ruling.
- 3) Owner makes specified modification(s) in consultation with an official class measurer, boat is inspected and reweighed. No corrector weights permitted.
- 4) Appropriate notation is made on official measurement Certificate.

2. **SECTION 2: BUILDERS AND OWNERS**

2.2 c) Cockpit Drains

SHARKS built by the “Shark Shoppe” above the number 1456 may have through transom cockpit drains instead of through hull drains. With the exception of the above, cockpit drain locations and diameters are to remain as built.

3. **SECTION 6: HULL, KEEL, AND RUDDER**

6.1 g) Hull/Deck Joint

The hull/deck joint may be fibre glassed in accordance with the following criteria:

- (i) Under section 2.3 of the Specifications, Builders and owners shall consult with ISCA and obtain written authorization before making any changes in construction of the boat, spars or equipment as covered by these Rules.
- (ii) The mechanical fastening of the joint shall remain in accordance with the original method of attachment, including use of the original type of fastening and in the same quantity.
- (iii) The use of fibreglass is only for the sealing of the joint and shall not be a substitute for the mechanical fastening on the hull.



- (iv) If there is a reduction in weight because of this work, one of the following shall take place:
 - (A) for Boats above basic weight (2100 lbs), this reduction shall be considered weight relief.
 - (B) Boats below basic weight or boats that drop below the basic weight: the addition of corrector weights must be equal or greater to the weight reduction. This weight must be added at the following locations: The corrector weights must be permanently marked with the weight and shall be fastened in a permanent manner to the under side of the deck where it meets the hull. The weight shall be placed in front of the main bulkhead and/or in the area of the cockpit seats.
- (v) The boat shall be weighed at the basic weight before and after the work is complete, to determine if there was a reduction in weight. All original tracks, railings, and fittings must be reinstalled upon completion of work.
- (vi) Boats that have a vinyl rub rail will have to remove this rail in order to glass over the hull/deck joint. The vinyl rub rail cannot be reinstalled after the work is complete, as this rail was an integral part of the original hull/deck joint. The removal of the vinyl rub rail will be permitted for the purpose of glassing the hull/deck joint. It should be noted that the rub rail is heavy and there will likely be a reduction of weight once the glassing over of the joint is complete which will require compliance with the above procedure.