

ACCESSORIES AU UNLIMITED LLC.

OPERATOR'S MANUAL

ACCESSORIES UNLIMITED SKID STEER BLOWER
MOVE ANY AMOUNT OF SNOW WITH EASE AND RELIABILITY

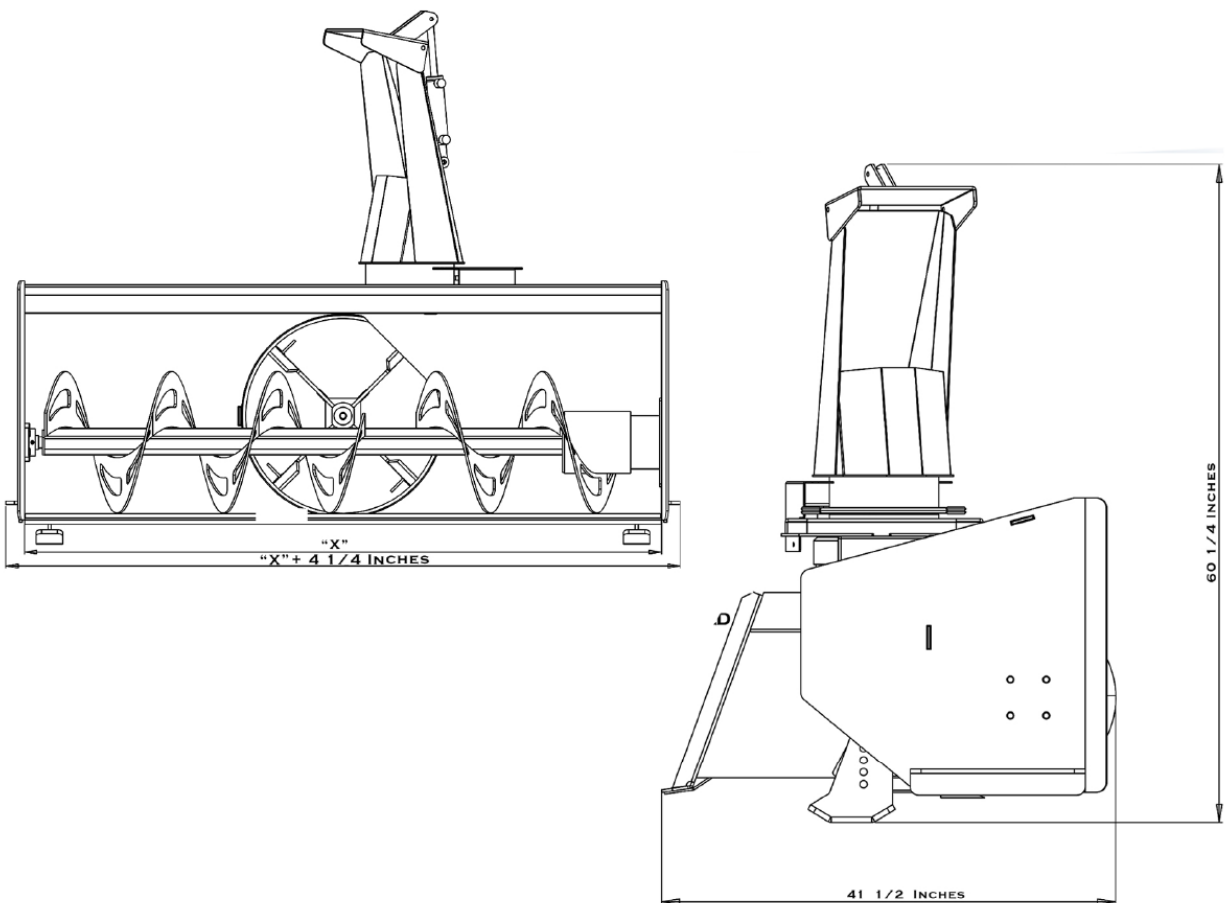

MADE IN THE USA

TABLE OF CONTENTS

INTRODUCTION	1
TO THE PURCHASER	1
SAFETY PRECAUTIONS.....	2
BEFORE OPERATION.....	2
NOTICE.....	3
THE SNOWBLOWER	3
BEFORE OPERATION.....	3
SNOWBLOWER OPERATION	4
THE SKID STEER.....	5
GENERAL INFORMATION	5
OPERATING THE SKID STEER	5
DURING OPERATION	6
ROLL-OVER PROTECTIVE STRUCTURE (ROPS) DURING OPERATION....	6
MAINTENANCE.....	7
TRANSPORTING	8
STORAGE	8
OPERATION.....	9
GENERAL PREPARATION.....	9
ENGINE SPEED	9
INCREASING TRACTION AND STABILITY	9
ENGAGING THE DRIVE MECHANISM	9
DEFLECTOR ADJUSTMENT IF MANUAL	10
SKID SHOE ADJUSTMENT	10
SNOW REMOVAL METHODS	11
MAINTENANCE	12
LUBRICATION.....	13
PARTS.....	14
INTRODUCTION	14
SKID STEER BLOWER PARTS AND ASSEMBLY AU-01-1500 REV 5	15
SKID STEER BLOWER PARTS AND ASSEMBLY AU-01-1501 REV 1	16
HOSES.....	17
SKID STEER BLOWER HYDRAULIC PARTS AND ASSEMBLY AU-02-3200	18
SKID STEER PLUG WIRING PINS.....	20
WIRING GUIDE	21
TORQUE SPECIFICATION TABLE.....	23
WARRANTY.....	24

INTRODUCTION

TO THE PURCHASER

All products are designed to give safe, dependable service if they are operated and maintained according to instructions. Read and understand this manual before operation.

This manual has been prepared to assist the owner and operators in the safe operation and suitable maintenance of the equipment. The information was applicable to products at the time of manufacture and does not include modifications made afterwards.

Read and understand this operator's manual before attempting to put equipment into service. Familiarize yourself with the operating instructions and all the safety recommendations contained in this manual and those labeled on the equipment and on the skid steer. Follow the safety recommendations and make sure that those with whom you work follow them.

Illustrations

The illustrations may not necessarily reproduce the full detail and the exact shape of the parts or depict the actual models, but are intended for reference only.

Direction Reference

All references to right and left, forward or rearward, are from the operator's seat, facing the steering wheel.

SERIAL PLATE

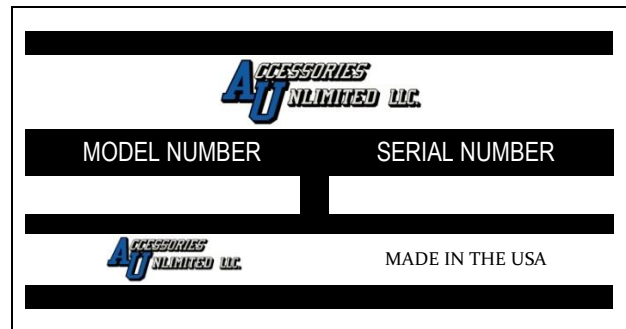

To assist your dealer in handling your needs, please record hereafter the model number and the serial number of your equipment and skid steer. It is also advisable to supply them to your insurance company. It will be helpful in the event that an equipment or skid steer is lost or stolen.

SKID STEER

IMPLEMENT

MODEL: _____

SERIAL NUMBER: _____

DATE OF PURCHASE: _____

DEALER NAME: _____

SAFETY PRECAUTIONS



SAFETY FIRST

This symbol, the industry's "Safety Alert Symbol", is used throughout this manual and on labels on the machine itself to warn of the possibility of personal injury. Read these instructions carefully. It is essential that you read the instructions and safety regulations before you attempt to assemble or use this unit.



DANGER: Indicates an immediate hazardous situation which, if not avoided, will result in death or serious injury.



WARNING: Indicates a potentially hazardous situation which, if not avoided, will result in death or serious injury.



CAUTION: Indicates a potentially hazardous situation which, if not avoided, may result in minor or moderate injury.

IMPORTANT: Indicates that equipment or property damage could result if instructions are not followed.

NOTE: Gives helpful information.

All products are designed to give safe, dependable service if they are operated and maintained according to instructions. **Read and understand this manual before operation.** It is the owner's responsibility to be certain anyone operating this product reads this manual, and all other applicable manuals to become familiar with this equipment and all safety precautions. Failure to do so could result in serious personal injury or equipment damage. If you have any questions, consult your dealer.

BEFORE OPERATION

Children

Tragic accidents can occur if the operator is not alert to the presence of children. Children are generally attracted to machines and work being done. Never assume children will remain where you last saw them.

1. Keep children out of the operating area and under the watchful eye of another responsible adult.
2. Be alert and turn machine off if children enter the work area.
3. Before and when backing, look behind for small children.
4. Never carry children while operating the machine. They may fall off and be seriously injured or interfere with the safe operation of the machine.
5. Never allow children to play on the machine or attachment even when they are turned off.
6. Never allow children to operate the machine even under adult supervision.
7. Use extra care when approaching blind corners, shrubs, trees, or other obstructions that might hide children from sight.

SAFETY PRECAUTIONS — CONTINUED

NOTICE

A safe operator is the best assurance against accidents. All operators, no matter how experienced they may be, should read this operator's manual and all other related manuals before attempting to operate the equipment. Please read the following section and pay particular attention to all safety recommendations contained in this manual and those labeled on the equipment and on the skid steer.

THE SNOWBLOWER

Before Operation

1. Read and understand this operator's manual and skid steer operator's manual. Know how to operate all controls and how to stop the unit and disengage the controls quickly.
2. Never wear loose, torn, or bulky clothing around the skid steer and the snowblower. It may catch on moving parts or controls, causing injury.
3. Before and during the snow season, thoroughly inspect the area where the equipment is to be used and remove all objects that may cause damage to the equipment.
4. Set transmission to neutral and disengage clutch, if equipped, before starting the engine.
5. Do not operate equipment in wintertime without wearing adequate winter garments and protective clothing.
6. Never attempt to make any adjustments while engine is running. Read this manual carefully to acquaint yourself with the equipment as well as the skid steer operator's manual. Working with unfamiliar equipment can lead to accidents. Be thoroughly familiar with the controls and proper use of the equipment.
7. Keep all safety guards in place and verify hardware for proper tightening.
8. Check for moving parts excessive wear regularly. Replace worn parts with genuine parts.
9. Replace all missing, illegible, or damaged safety and warning decals. See list of decals in operator's manual.
10. Keep safety decals clean of dirt and grime.
11. Do not modify or alter this equipment or any of its components, or any equipment or any of its components, or any equipment function without first consulting your dealer.
12. Use of counterweights is recommended. Weights provide the necessary balance to improve stability, traction and steering. Use only those recommended by your dealer.

SAFETY PRECAUTIONS — CONTINUED

Snowblower Operation

1. Before leaving the skid steer unattended, take all possible precautions. Park the skid steer/snowblower on level ground, place the transmission in neutral, set the parking brake, disengage the Aux hydraulics, lower the equipment to the ground, place all levers including auxiliary control levers in neutral, shut off the engine and remove the ignition key.
2. Before starting the skid steer/snowblower, remove any ice that has accumulated in the auger/fan.
3. Prior to operation, clear work area of all objects that can be picked up and thrown. Mark all curbs, pipes, etc. that cannot be moved.
4. Be sure the Aux hydraulics switch/lever is in OFF position before starting engine.
5. Exercise extreme caution when operating on or crossing a gravel drive, walks, or roads. Stay alert for hidden hazards or traffic.
6. Do not carry passengers.
7. Adjust skid shoes – housing height to clear gravel or crushed rock surface.
8. Keep clear of rotating parts. Do not put hands or feet under or into snowblower with engine running, and allow the rotating parts to stop BEFORE unclogging the collector/fan housing or chute, and making any repairs, adjustments or inspections. Use only a 36" long piece of wood to unclog blower.
9. Park the skid steer/snowblower on level ground, place the transmission in neutral, set the parking brake, disengage the Aux hydraulics, lower the equipment to the ground, place all control levers in neutral, shut off the engine, remove the ignition key and allow the rotating parts to stop BEFORE unclogging the collector/fan housing or chute, and making any repairs, adjustments or inspections. Use only a 36" long piece of wood to unclog blower.
10. If the snowblower starts to vibrate abnormally, disengage the Aux hydraulics, stop the engine immediately and check for cause. Excessive vibration is generally a sign of trouble.
11. Do not run the engine indoors except when starting engine and transporting attachment in or out of building. Carbon monoxide gas is colorless, odorless and deadly.
12. Do not attempt to operate on steep slopes. If operating on slopes is necessary, exercise extreme caution when changing direction.
13. Never operate snowblower without guards, and other safety protective devices in place.
14. Keep clear of chute discharge. This chute has the capability of throwing objects at far distances.
15. Never operate snowblower near glass enclosures, automobiles, window wells, embankments, etc. without proper adjustment of snow discharge angle.
16. Never operate machine at high transport speeds on a slippery surface.
17. Use extra caution when backing up.
18. Do not direct discharge at bystanders or animals. Ejected objects may cause injury.
19. Disengage power to auger/fan when transporting or when not in use.
20. Never operate the snowblower without good visibility and lighting.
21. Prolonged exposure to loud noise can cause impairment or loss of hearing. Wear a suitable hearing device such as earmuffs or earplugs to protect against objectionable or uncomfortable noises.
22. Never allow anyone near the work area.

SAFETY PRECAUTIONS — CONTINUED

THE SKID STEER

General Information

1. Read the operator's manual carefully before using skid steer. Lack of operating knowledge can lead to accidents.
2. Do not permit anyone but the operator to ride on the skid steer. There is no safe place for passengers.

Operating the Skid Steer

1. Never run the skid steer engine in a closed building without adequate ventilation, as the exhaust fumes are very dangerous.
2. Adopt safe driving practice: Keep the parking brake on at all times during transportation.
3. Always drive at a safe speed relative to local conditions and ensure that your speed is low enough for an emergency stop to be safe and secure.
4. Reduce speed prior to turns to avoid the risk of overturning. Keep speed to a minimum.
5. Always keep the skid steer in gear to provide engine braking when going downhill. Do not coast.
6. Never allow an open flame near the fuel tank or battery.
7. Make sure the proper shields are installed when using the equipment and always replace the shields if damaged.
8. Park the skid steer/snowblower on level ground, place the transmission in neutral, set the parking brake, disengage the Aux hydraulics, lower the equipment to the ground, place all levers including auxiliary control levers in neutral, shut off the engine and remove the ignition key BEFORE leaving the skid steer.
9. Never park the skid steer on a steep slope.
10. Do not attempt to operate on steep slopes. Avoid sudden uphill turns on steep slopes.
11. Use of counterweights for better traction and stability is recommended.
12. Handle fuel with care, as it is highly flammable.
13. Use approved fuel container.
14. Never add fuel to running engine or a hot engine.
15. Fill fuel tank outdoors with extreme care. Never fill fuel tank indoors. Replace fuel cap securely and wipe up spilled fuel.
16. Never allow anyone to operate the snowblower until they have read the manual completely and are thoroughly familiar with basic skid steer and snowblower operation.
17. Make sure the skid steer is counterweighted as recommended by your dealer. Weights provide the necessary balance to improve stability, traction and steering.
18. Always make sure all snowblower components are properly installed and securely fastened BEFORE operation.
19. Never attempt to start the engine and/or engage snowblower drive while standing beside the skid steer.
20. Always start the engine from the operator's seat with all the transmission lever(s) and snowblower drive lever in neutral.
21. DO NOT bypass the safety system by shorting across the terminals of the starter motor to start the engine. This may cause the skid steer to move suddenly.
22. If the safety start system does not work, consult your dealer immediately.

SAFETY PRECAUTIONS — CONTINUED

During Operation

1. Do not allow passengers on the skid steer/snowblower at any time. There is no safe place for passengers on the equipment. The operator **MUST** sit in the skid steer seat.
2. Eye and hearing protection is recommended when operating the snowblower.
3. Operate only during daylight hours, or when the area is well lit with bright artificial light.
4. Park the skid steer/snowblower on level ground, place the transmission in neutral, set the parking brake, disengage the Aux hydraulics, lower the equipment to the ground, place all control levers in neutral, shut off the engine and remove the ignition key **BEFORE** leaving the operator's seat.
5. Inspect the snowblower after striking any foreign object to assure that all snowblower parts are safe and secure and not damaged.
6. Be especially observant of the operating area and terrain. Watch for holes, rocks, or other hidden hazards. **ALWAYS** inspect the area prior to blowing.
7. **DO NOT** blow near the edge of drop-offs or banks.
8. **DO NOT** blow on steep slopes as overturn may result.
9. Operate up and down (not across) intermediate slopes. Avoid sudden starts and stops.
10. Drive skid steer backwards up steeper slopes with blower off. Then blow as you travel down the slope.
11. Slow down before you change directions on any slope.
12. Use wheel weights on your skid steer to increase stability on slopes.
13. Never stand alongside of the unit while the engine is running.

Roll-Over Protective Structure (ROPS) During Operation

1. **DO NOT** weld, drill or alter the ROPS. Damaged ROPS must not be straightened or used. If damage does occur, consult your dealer.
2. If ROPS is lowered or removed from the skid steer for any reason, it must be erected and/or refitted immediately. Original bolts or equivalent replacements must be used and tightened to the correct torque.
3. Your dealer does not recommend usage of skid steer with ROPS removed.
4. Seat belt usage: With ROPS installed on the skid steer it is imperative that the seat belt be installed, used and correctly adjusted, at all times. **DO NOT** use a seat belt if operating without ROPS.
5. Keep all shields and covers in place. All skid steer and equipment shields and covers must be correctly installed at all times. When necessary to remove these, they must be reinstalled immediately.
6. Keep clear of all rotating driveline components. Be especially observant of implement areas of discharge, intake or other mechanical motion.
7. Securely lock equipment drive shaft. Check that all skid steer and equipment drivelines are in good working order.
8. Additional safety equipment: A fire extinguisher and first aid kit should be kept readily accessible. These are available through your dealer.

SAFETY PRECAUTIONS — CONTINUED

MAINTENANCE

Always use genuine parts when replacement parts are required during operation.

1. Keep the skid steer and snowblower properly maintained.
2. Park the skid steer/snowblower on level ground, place the transmission in neutral, set the parking brake, disengage the Aux hydraulics, lower the equipment to the ground, place all control levers in neutral, shut off the engine and remove the ignition key and allow the rotating parts to stop BEFORE making any snowblower adjustments.
3. To avoid injury, do not adjust, unclog or service the snowblower with the skid steer engine running. Make sure rotating components have completely stopped before leaving the operator's seat.
4. Keep the skid steer/snowblower clean. Snow and ice build-up can lead to malfunction or personal injury from thawing and refreezing in garage.
5. Always wear eye protection when cleaning or servicing the snowblower.
6. Service the unit in safety: DO NOT service the skid steer while the engine is running or hot, or if the unit is in motion. Always lower snowblower to the ground. If necessary to service unit with blower raised, securely support with stands or suitable blocking before working underneath. Do not rely on hydraulically supported devices for your safety. They can settle suddenly, leak down, or be accidentally lowered.
7. Do not attempt to service machine, clear obstructions or unplug blockages with the engine running. Always shut off engine and allow all motion to cease.
8. The manufacturer will not claim responsibility for fitment of unapproved parts and/or accessories and any damages as a result of their use.
9. Make sure all shields and guards are securely in place following all service, cleaning, or repair work.
10. Do not modify or alter this equipment or any of its components or operating functions. If you have any questions concerning modifications, consult with your dealer.
11. Do not operate a unit which is defective or has missing parts. Make sure that all recommended maintenance procedures are completed before operating the unit.
12. Check all controls regularly and adjust where necessary.
13. Periodically check all nuts and bolts for tightness, especially wheel hub and rim nuts.
14. Snowblower fan and auger must be checked for tightness. Remove any twine, wire, etc. that may have wrapped on the fan or the auger.
15. To avoid serious personal injury: Escaping hydraulic/diesel fluid under pressure can penetrate the skin causing serious injuries. Do not use your hands to check for leaks. Use a piece of cardboard or paper to search for leaks.
16. Stop engine and relieve pressure before connecting lines. Tighten all connections before starting engine or pressurizing lines.

SAFETY PRECAUTIONS — CONTINUED

TRANSPORTING

1. Transporting on public roadway: When driving the skid steer and equipment on the road or highway under 25 mph, at night or during the day, use flashing amber warning lights and the Slow Moving Vehicle ("SMV") identification emblem.
2. Check local traffic codes that may apply to unit usage on public roads and highways in your area. The use of flashing amber lights is acceptable in most localities. However, some localities may prohibit their use.
3. Always disengage equipment drive prior to transporting unit.

STORAGE

Before storing the snowblower, certain precautions should be taken to protect it from deterioration.

1. Clean the snowblower throughout.
2. Make all the necessary repairs.
3. Replace all safety signs that are damaged, lost, or otherwise become illegible. If a part to be replaced has a sign on it, obtain a new safety sign from your dealer and install it in the same place as on the removed part.
4. Repaint all parts from which paint has worn or peeled.
5. Lubricate the snowblower as instructed under the "*Lubrication*" section.
6. When the snowblower is dry, oil all moving parts. Apply oil liberally to all surfaces to protect against rust.
7. Store in a dry place.

OPERATION

GENERAL PREPARATION

1. Read the operator's manual carefully before using the skid steer and snowblower. Be thoroughly familiar with the controls and proper use of the equipment. Know how to stop the unit and disengage the controls quickly.
2. Wear adequate winter outer garments while operating the equipment.
3. Make sure the snowblower is clear of snow and other material before engaging the snowblower.
4. Make sure the auger and fan operate freely.
5. Adjust the skid shoes so the snowblower runs leveled.
6. Before engaging the snowblower drive, always have the engine running at idle.
7. Operate the snowblower at maximum to 3/4 engine RPM.

Engine Speed

1. Start the skid steer engine. Let the engine warm up at least one minute before engaging the drive mechanism then increase speed gradually.
2. Make sure the snowblower head is properly positioned and engage the drive mechanism.
3. Adjust the ground speed according to conditions. For maximum power, run engine at or near full throttle.

IMPORTANT: Use full RPM power when removing wet, sticky snow. Low RPM power will tend to clog the chute.



WARNING: To avoid serious personal injury: Do not use your hands to unclog the chute. Use a 36" (925mm) stick or board. Do not attempt to unclog the chute while engine is running. If the chute is clogged, shut off the skid steer engine, remove the key and allow the rotating parts to stop before removing the snow from the chute.

Increasing Traction and Stability

The use of approved tire chains and wheel weights is recommended for extra traction and stability, especially when operating in snow and/or on slippery surfaces. See your dealer for details.

Engaging the Drive Mechanism

Refer to the skid steer's operating manual for instructions.

OPERATION — CONTINUED



WARNING: To avoid serious personal injury: Make sure skid steer engine and snowblower come to a complete stop and skid steer drive mechanism is disengaged BEFORE making any adjustments.

Deflector Adjustment if Manual

The deflector angle must be set according to the distance the snow must be thrown. To adjust the angle:

- Turn the chute to right as far as possible.
- Remove hairpin from adjustment tube and adjust the deflector with the adjustment rod.
- Reinsert hairpin in adjustment tube.

Skid Shoe Adjustment

Adjust the skid shoes so that the snowblower runs level and according to the surface conditions so that stones are not thrown with the snow.

Adjust both skid shoes to the same height to keep the cutting edge level and adjust upwards for smooth surfaces.

Remove skid shoe bolts (item 2) and adjust according to instructions below, and securely tighten bolts:

Clearance between cutting edge and surface:

- Level paved surface: Adjust to 1/16" to 1/8"
- Uneven or gravel surface: Adjust 1/2" to 5/8"

OPERATION — CONTINUED

SNOW REMOVAL METHODS

When removing snow, do not use the snowblower as a dozer blade to push snow. Let the snowblower work its way through deep drifts. If the speed of your skid steer is too fast, the snowblower may become overloaded and clog. For best results, raise the snowblower and remove a top layer of snow. A second pass with the snowblower will remove the remaining snow.

IMPORTANT: Use full RPM power when removing wet, sticky snow. Low RPM power will tend to clog the chute.



WARNING: To avoid serious personal injury: Do not use hands or feet to unclog chute. Do not attempt to clear clogged chute of snow while skid steer engine is running. If the chute clogs, disengage the Aux hydraulics, shut off the skid steer engine, set the parking brake, lower snowblower to the ground, place transmission in neutral, remove the ignition key, wait for all movement to stop, then clear the snow from the chute.

A definite pattern of operation is required to thoroughly clean the snow area. These patterns will avoid throwing snow in unwanted places as well as eliminating a second removal of snow.

PATTERN 1

DISCHARGE SNOW BOTH SIDES

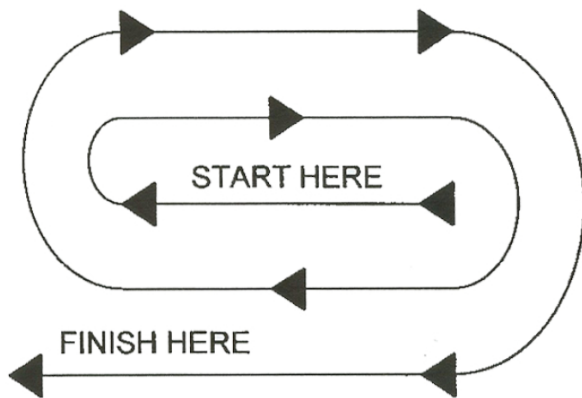

DISCHARGE SNOW BOTH SIDES

Where it is possible to throw the snow to the left and right (above), as on a long driveway, it is advantageous to start in the middle. Plow from one end to the other, throwing snow to both sides without changing the direction of the discharge guide.

PATTERN 2

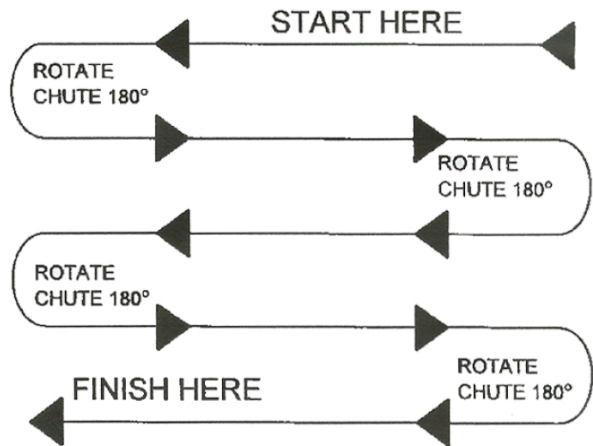

DISCHARGE SNOW THIS SIDE ONLY

If the snow can only be thrown to one side of the driveway or sidewalk (above), start on the opposite side. At the end of the first pass, rotate the discharge guide 180 degrees for the return pass. At the end of each succeeding pass, rotate the discharge guide 180 degrees to maintain direction of throw in the same area.

MAINTENANCE

Always use genuine parts when replacement parts are required.



WARNING: To avoid serious personal injury:

- Before cleaning, adjusting or repairing the snowblower: Bring the skid steer to a complete stop, disengage the Aux hydraulics, apply parking brake, lower the implement to the ground, shut off the engine and remove the ignition key.
- Never park the skid steer inside a building where an open flame or sparks are present. Allow the engine to cool down before storing in any enclosure.
- Run the snowblower a few minutes after blowing snow to prevent freeze up of auger and fan.
- Provide adequate blocking before working under the snowblower when in raised position.

MAINTENANCE — CONTINUED

LUBRICATION

Use oil or grease gun and lubricate as follows:

DESCRIPTION	INTERVAL	LUBRICATION REQUIRED
Bearing	8 hours of operation	Grease each auger bearing.

PARTS

INTRODUCTION

All parts are illustrated in "exploded views" which show the individual parts in the normal relationship to each other. Reference numbers are used in the illustrations. These numbers correspond to those in the "*Item No.*" column, and are followed by the description and quantity required.

The manufacturer reserves the right to change, modify, or eliminate from time to time, for technical or other reasons, certain or all data, specifications, or the product or products themselves, without any liability or obligation.

PARTS — CONTINUED

SKID STEER BLOWER PARTS AND ASSEMBLY

AU-01-1500 REV 5

ITEM NO.	PART NUMBER	DESCRIPTION	QTY.
1	AU-02-1505 Rev 3	Auger Motor Mount	1
2	AU-02-1504-Width Rev 2	Auger	1
3	104-4236-006	Auger Drive Motor	1
4	105-1488-006 For 84" 105-1374-006 For 72"	Fan Impeller Motor	1
5	AU-02-1502 Rev 3	Chute Assembly	1
6	AU-01-1600	Chute Tip Cylinder	1
7	AU-02-1602	Foot	2
8	AU-02-1671	Left Skid Shoe	1
9	AU-02-1672	Right Skid Shoe	1
10	AU-03-1673	Auger Motor Inspection Cover	1
11	AU-03-1504-Width	Cutting Edge	1
12	AU-03-1510	Rotation Motor	1
13	AU-03-5042	Rotation Sprocket	1
14	AU-03-1645	Chute Hold Down	2
15	AU-03-1625	1.750 Flange Bearing	1
16	AU-03-1674	Fan Restrictor	1
17	AU-03-5043	Rotation Guard	1
18	AU-03-1687	Chute Riser Pad	4
19	AU-03-5114	Spacer	1
20	AU-03-5093	Chute Spacer Plate	4
21	AU-03-3014	Impeller Fan Nut	1
22	AU-03-3015	Lock Washer	1
23	.125 x 2.00 Cotter Pin	Cotter Pin	1
24	AU-02-1613 Rev4	Blower Body	1
27	AU-02-1501-Rev 4	Fan	1
28	AU-03-1775	Wire Harness	1
29	AU-03-5121	Manual Canister	1
30	PH250-FT12	-10 Male ORB to 1/4"NPT Female Rigid	2
31	PH500-FT11	-10 Male ORB to 1/2" NPT Female Swivel	4
32	Manifold Block Assembly	See Break Down	1
33	PH250-FT05	1/4" NPT ST 90	2
34	AU-03-1686-Width	Hydraulic Guard	1

- A- Warning Do Not put Hands in Decal
- B- Accessories Unlimited Contact Info Decal
- C- Accessories Unlimited Logo Decal (Large)
- D- Auger Warning Decal
- E- Model/Serial Number Decal
- F- Grease Daily Decal
- G- Accessories Unlimited Logo Decal (Small)
- H- Caution Do Not Operate with Guard Removed Decal

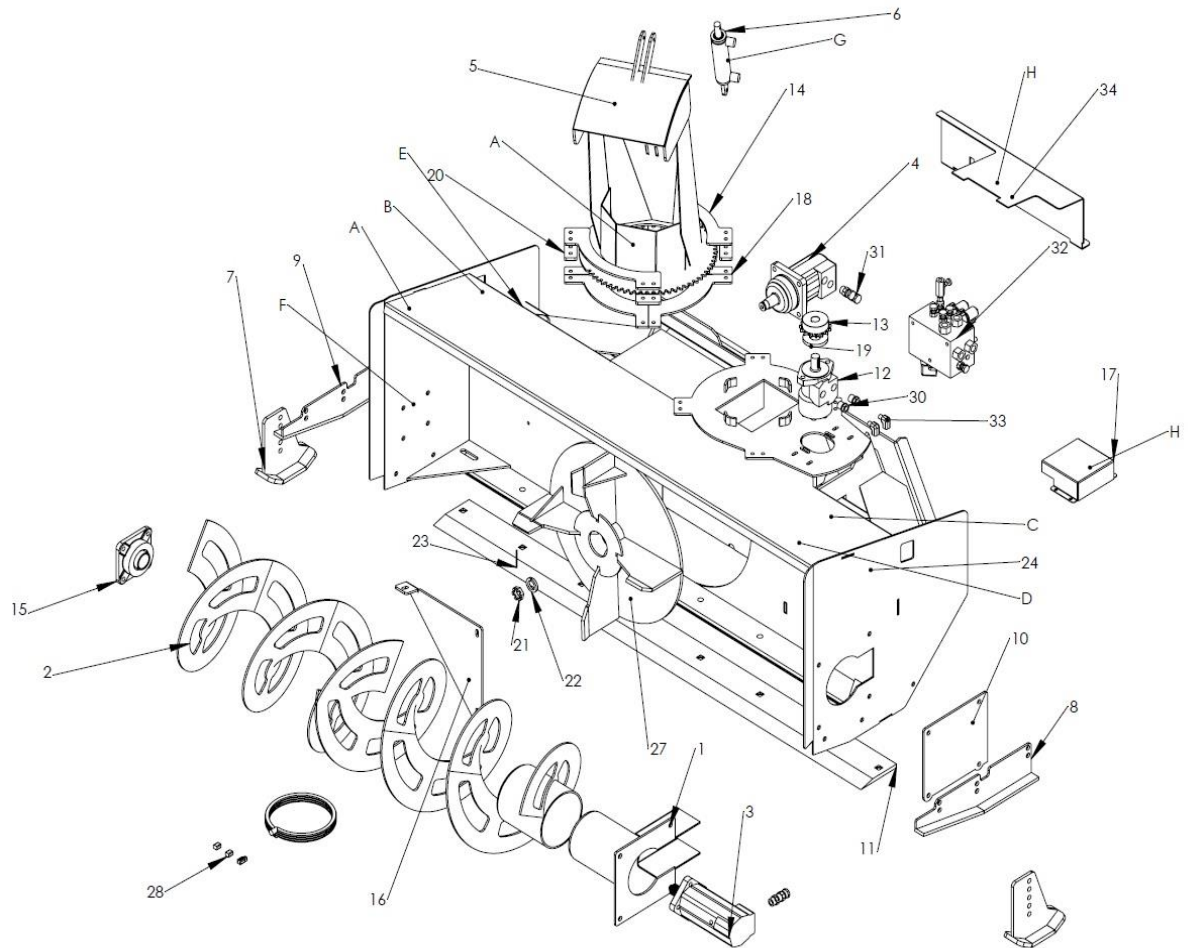

PARTS — CONTINUED

SKID STEER BLOWER PARTS AND ASSEMBLY

AU-01-1501 REV 1

ITEM NO.	PART NUMBER	DESCRIPTION	QTY.
1	AU-02-1613-20-Width	Blower Body	1
2	105-1556-006	Fan Motor	1
3	AU-02-1501-20	Impeller Fan	1
4	AU-03-1504-Width	Cutting Edge	1
5	AU-02-1504-Width Rev 2	Auger	1
6	AU-02-1505 Rev 3	Auger Motor Mount	1
7	104-4236-006	Auger Motor	1
8	AU-03-1625	1.750 Flange Bearing	1
9	AU-02-1602	Foot	2
10	AU-02-1672	Right Skid Shoe	1
11	AU-02-1671	Left Skid Shoe	1
12	AU-03-3014	Fan Nut	1
14	.125 x 2.00 Cotter Pin	Cotter Pin	1
14	AU-03-3015	Lock Washer	1
15	AU-02-1502-20	Chute Assembly	1
16	AU-03-1645-20	Chute Hold Down	2
17	AU-03-1510	Rotation Motor	1
18	AU-03-5114	Spacer	1
19	AU-03-1687-20	Chute Riser Pad	4
20	AU-03-5093	Chute Spacer Plate	4
21	AU-03-5042	Rotation Sprocket	1
22	AU-03-5043	Rotation Guard	1
23	AU-03-1674-20	Fan Restrictor	1
24	AU-03-1673	Auger Motor Inspection Cover	1
25	AU-01-1600	Chute Tip Cylinder	1
26	AU-03-1686-20-Width	Hydraulic Guard	1
27	Manifold Block Assembly	See Break Down	1
28	AU-03-5121	Manual Canister	1
29	PH250-FT12	-10 Male ORB to ¼" NPT Female Rigid	2
30	PH250-FT05	¼" NPT ST 90	2
31	PH500-FT11	-10 Male ORB to ½" NPT Female Swivel	4

- A – Warning Do Not Put Hands In Decal
- B – Accessories Unlimited Website Decal
- C – Large Accessories Unlimited Logo Decal
- D – Auger Warning Decal
- E – Serial Number Decal
- F – Grease Daily Decal
- G – Small Accessories Unlimited Logo Decal
- H – Caution Do Not Operate With Guard Removed Decal

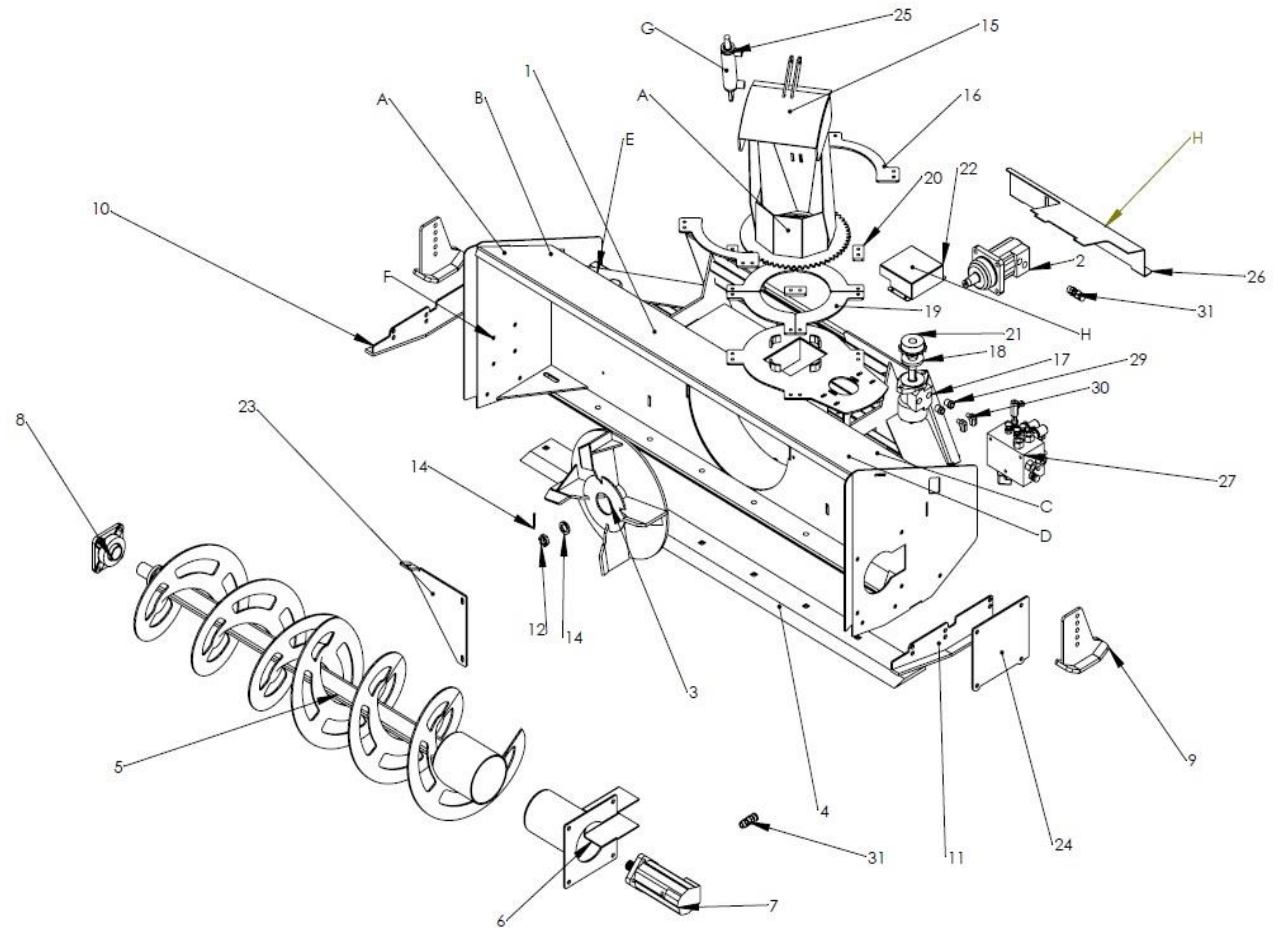

PARTS – CONTINUED

HOSES

Part Number-1/2" Hoses	Location	Qty	Over all length
AU-03-PH512	Auger Motor Bottom Port to Manifold Block	1	14"
AU-03-PH524	Auger Motor Top Port to Manifold Block	1	26"
AU-03-PH540	Impellar Motor Bottom Port to Manifold Block	1	42"
AU-03-PH540	Impellar Motor Top Port to Manifold Block	1	42"
AU-03-PH584	Pressure from Machine to Manifold block	1	86"
AU-03-PH5108	Return to Machine from Manifold block	1	110"
PHSL500	Abrasion Sleeve	1	60"

Part Number- 1/4" Hose 1500-84	Location	Qty	Over all length
AU-03-PH2515	Rotation Motor to Manifold Block	2	17"
AU-03-PH2556	Chute Tip To Manifold Block	1	58"
AU-03-PH2556	Impellar Case Drain to Manifold Block	1	58"
AU-03-PH2562	Chute Tip To Manifold Block	1	64"

Part Number- 1/4" Hose 1500-72	Location	Qty	Over all length
AU-03-PH2556	Chute Tip To Manifold Block	1	58"
AU-03-PH2550	Chute Tip To Manifold Block	1	52"
AU-03-PH2550	Impellar Case Drain to Manifold Block	1	52"
AU-03-PH2512	Rotation Motor to Manifold Block	2	14"

Part Number- 1/4" Hose 1501-66&72	Location	Qty	Over all length
AU-03-PH2556	Chute Tip To Manifold Block	1	58"
AU-03-PH2550	Chute Tip To Manifold Block	1	52"
AU-03-PH2550	Impellar Case Drain to Manifold Block	1	52"
AU-03-PH2509	Rotation Motor to Manifold Block	2	11"

Part Number- 1/4" Hose 1501-84	Location	Qty	Over all length
AU-03-PH2556	Impellar Case Drain to Manifold Block	1	58"
AU-03-PH2556	Chute Tip To Manifold Block	1	58"
AU-03-PH2562	Chute Tip To Manifold Block	1	64"
AU-03-PH2518	Rotation Motor to Manifold Block	2	20"

PARTS — CONTINUED

SKID STEER BLOWER HYDRAULIC PARTS AND ASSEMBLY

AU-02-3200 MANIFOLD BLOCK

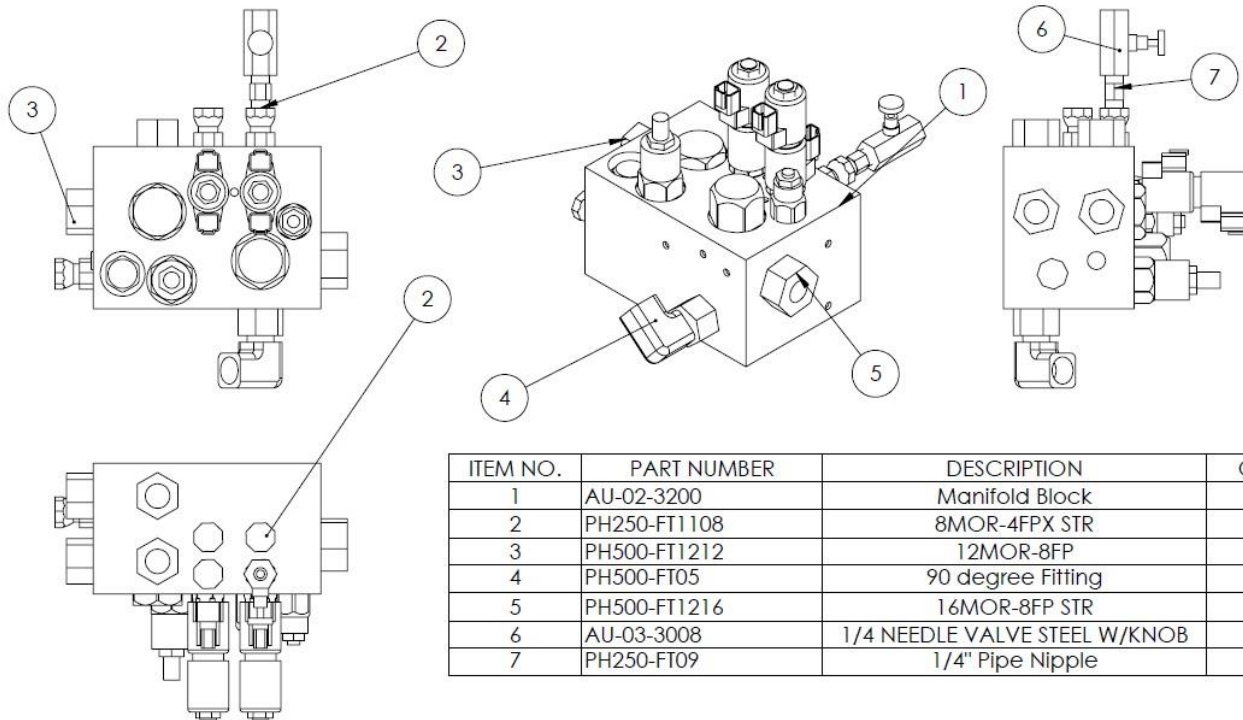

ITEM NO.	PART NUMBER	DESCRIPTION	QTY.
1	AU-02-3200	Manifold Block	1
2	PH250-FT1108	8MOR-4FPX STR	5
3	PH500-FT1212	12MOR-8FP	5
4	PH500-FT05	90 degree Fitting	1
5	PH500-FT1216	16MOR-8FP STR	1
6	AU-03-3008	1/4 NEEDLE VALVE STEEL W/KNOB	1
7	PH250-FT09	1/4" Pipe Nipple	1

PARTS — CONTINUED

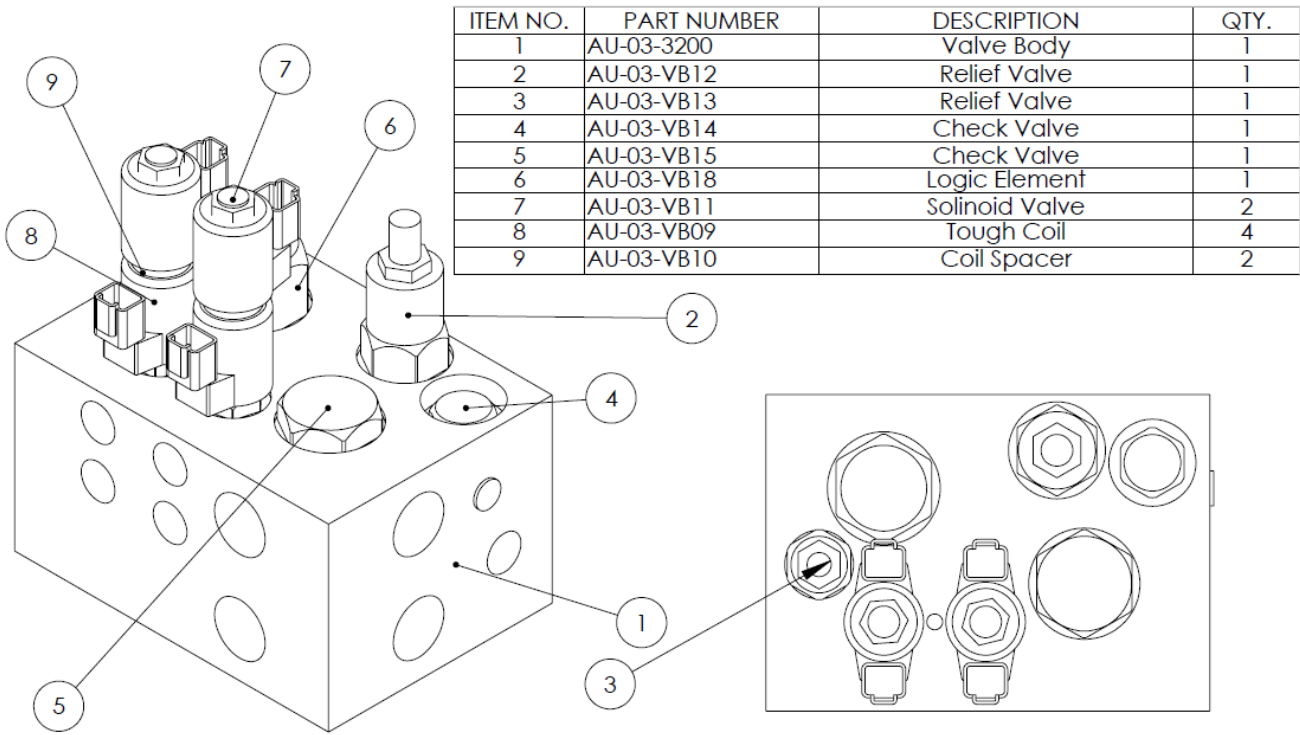

ITEM NO.	PART NUMBER	DESCRIPTION	QTY.
1	AU-03-3200	Valve Body	1
2	AU-03-VB12	Relief Valve	1
3	AU-03-VB13	Relief Valve	1
4	AU-03-VB14	Check Valve	1
5	AU-03-VB15	Check Valve	1
6	AU-03-VB18	Logic Element	1
7	AU-03-VB11	Solnoid Valve	2
8	AU-03-VB09	Tough Coil	4
9	AU-03-VB10	Coil Spacer	2

PARTS — CONTINUED

SKID STEER PLUG WIRING PINS	
------------------------------------	--

Bobcat & Gehl 14 Pin

Black Wire- Letter B
Yellow Wire- Letter G
Red Wire- Letter H
Blue Wire- Letter E
Green Wire- Letter F

Cat 14 Pin

Black Wire- Letter B
Yellow Wire- Letter C
Red Wire- Letter D
Blue Wire- Letter E
Green Wire- Letter F

Cat 8 Pin

Black Wire- Letter A
Yellow Wire- Letter B
Red Wire- Letter H
Blue Wire- Letter D
Green Wire- Letter C

F & G need to be jumped for high flow

John Deere 14 Pin

Black Wire- Letter A
Yellow Wire- Letter G
Red Wire- Letter C
Blue Wire- Letter E
Green Wire- Letter D

Case 14 Pin

Black Wire- Letter B
Yellow Wire- Letter C
Red Wire- Letter D
Blue Wire- Letter E
Green Wire- Letter F

Kubota 14 Pin

Black Wire- Letter B
Yellow Wire- Letter G
Red Wire- Letter H
Blue Wire- Letter E
Green Wire- Letter F

ICB 14 Pin

Black Wire- Letter B
Yellow Wire- Letter D
Red Wire- Letter C
Blue Wire- Letter E
Green Wire- Letter F

ASV 8 Pin

Black Wire- Letter A
Yellow Wire- Letter B
Red Wire- Letter G
Blue Wire- Letter C
Green Wire- Letter D

New Holland 14 Pin

Black Wire- Letter B
Yellow Wire- Letter G
Red Wire- Letter H
Blue Wire- Letter E
Green Wire- letter F

Volvo

Black Wire- Letter B
Yellow Wire- Letter C
Red Wire- Letter D
Blue Wire- Letter E
Green Wire- Letter F

PARTS — CONTINUED

SKID STEER PLUG WIRING PINS	
------------------------------------	--

Mustang

Black Wire- Letter B
Yellow Wire- Letter C
Red Wire- Letter D
Blue Wire- Letter E
Green Wire- Letter F

Gehl

Black Wire- Letter B
Yellow Wire- Letter C
Red Wire- Letter D
Blue Wire- Letter E
Green Wire- Letter F

PARTS — CONTINUED

WIRING GUIDE

Wire Hook Up to Quick Disconnect

Black = - 12 Volt Ground

Yellow = + 12 Volt Shoot Up

Red = + 12 Volt Shoot Down

Blue = + 12 Volt Shoot Left

Green = + 12 Volt Shoot Right

Brown = Spare

Switch Kit

1. Place hand control in cab with enough extra cable so you can move around for use.
2. Run white and black wires back to battery so the white and black wires will reach the battery.
3. Now run the remaining wires to the front of the machine following the loader arms.
4. Cut wire to length and hook up to female quick disconnect.
5. Mount female quick disconnect near auxiliary hydraulic lines, use mounting plate included in box.
6. Connect wires from attachment to male end of quick disconnect.
7. Make sure the color wires from the female side match up with the color wires from the male side.
8. Connect black and white wires to battery, (black is negative, white is positive).
9. You are now ready to test the functions of the blower, to do so **auxiliary hydraulics will have to be on and running.**

TORQUE SPECIFICATION TABLE

GENERAL SPECIFICATION TABLE

Use the following torques when special torques are not given. Note: These values apply to fasteners as received from supplier, when dry. These values do not apply if lubricants are used.

BOLT SIZES (SAE)	TORQUE	
INCHES	POUNDS-FOOT	NEWTONS-METER
1/4	5	7
5/16	10	14
3/8	20	27
7/16	25	41
1/2	88	119
9/16	121	164
5/8	165	224
3/4	297	403
7/8	440	597
1	638	865
1 1/8	840	1139
1 1/4	1180	1600
1 3/8	1570	2129
1 1/2	2070	2807

BOLT SIZES (METRIC)	TORQUE	
MILLIMETERS	POUNDS-FOOT	NEWTONS-METER
M6	10	13
M8	22	30
M10	40	54
M12	59	80
M14	93	126
M16	130	176
M18	168	228
M20	205	278

WARRANTY

ACCESSORIES UNLIMITED LLC ATTACHMENTS

Accessories Unlimited LLC warrants to its authorized dealers who in turn warrant to the original owner, that each new Accessories Unlimited LLC attachment will be free from proven defects in material and workmanship for twelve (12) months after delivery by the authorized Accessories Unlimited LLC dealer to the original buyer.

During the warranty period, the authorized Accessories Unlimited LLC dealer shall repair or replace, at Accessories Unlimited LLC's option, without charge for parts and labor, any part of the Accessories Unlimited LLC product which fails because of defects in material or workmanship. The owner shall provide the authorized Accessories Unlimited LLC dealer with prompt written notice of the defect and allow reasonable time for replacement or repair. Accessories Unlimited LLC may, at its option, require failed parts to be returned to the factory. Travel time of mechanics and transportation of the Accessories Unlimited LLC product to the authorized Accessories Unlimited LLC dealer for warranty work are the responsibility of the owner. The remedies provided in this warranty are exclusive.

This warranty does not cover replacement of scheduled service items and high wear items. The owner shall rely solely on the warranty, if any, of the respective manufacturers thereof. This warranty does not cover damages resulting from abuse, accidents, alterations, use of the Accessories Unlimited LLC product as an attachment on any equipment not approved by Accessories Unlimited LLC, air flow obstructions, or failure to maintain or use the Accessories Unlimited LLC product according to the instructions applicable to it.

THIS WARRANTY IS EXCLUSIVE AND IN LIEU OF ALL OTHER WARRANTIES AND CONDITIONS, EXCEPT THE WARRANTY OF TITLE, ACCESSORIES UNLIMITED LLC DISCLAIMS ALL OTHER WARRANTIES AND CONDITIONS, EXPRESS OR IMPLIED, INCLUDING ANY IMPLIED WARRANTIES OR CONDITIONS OF MERCHANTABILITY OR FITNESS FOR A PARTICULAR PURPOSE. IN NO EVENT SHALL ACCESSORIES UNLIMITED LLC OR THE AUTHORIZED ACCESSORIES UNLIMITED LLC DEALER BE LIABLE FOR ANY SPECIAL, INCIDENTAL, INDIRECT OR CONSEQUENTIAL DAMAGES, WHATSOEVER, INCLUDING, BUT NOT LIMITED TO, LOSS OR INTERRUPTION OF BUSINESS, LOST PROFITS, OR LOSS OF MACHINE USE, WHETHER BASED ON CONTRACT, WARRANTY, TORT, NEGLIGENCE, STRICT LIABILITY, STATUTE OR OTHERWISE, EVEN IF ACCESSORIES UNLIMITED LLC OR THE AUTHORIZED ACCESSORIES UNLIMITED LLC DEALER HAS BEEN ADVISED OF THE POSSIBILITY OF SUCH DAMAGES. THE TOTAL LIABILITY OF ACCESSORIES UNLIMITED LLC AND THE AUTHORIZED ACCESSORIES UNLIMITED LLC DEALERS WITH RESPECT TO THE PRODUCT AND SERVICES FURNISHED HEREUNDER SHALL NOT EXCEED THE PURCHASE PRICE OF THE PRODUCT UPON WHICH SUCH LIABILITY IS BASED.



OPERATOR'S MANUAL
ACCESSORIES UNLIMITED SKID STEER BLOWER

MADE IN THE USA