

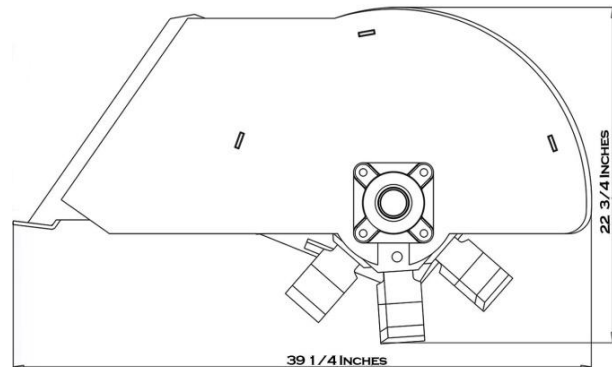

OPERATOR'S MANUAL

ACCESSORIES UNLIMITED ROTO TILLER
ENGINEERED TO FIT YOUR EVERY NEED

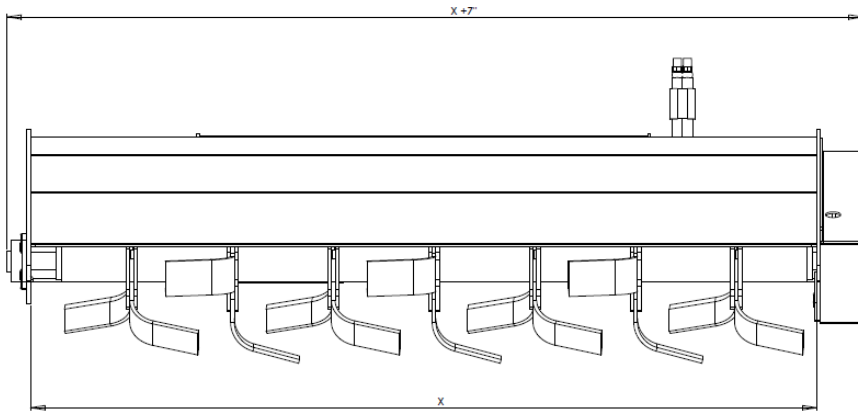

MADE IN THE USA

TABLE OF CONTENTS

INTRODUCTION	1
TO THE PURCHASER	1
SAFETY PRECAUTIONS.....	2
BEFORE OPERATION.....	2
NOTICE.....	3
SAFE OPERATION NEEDS A QUALIFIED OPERATOR	3
FIRE PREVENTION	4
THE ROTO TILLER	5
BEFORE OPERATION.....	5
AUXILIARY HYDRAULIC CONTROLS	6
ROTO TILLER OPERATION	6
THE SKID STEER.....	8
GENERAL INFORMATION	8
OPERATING THE SKID STEER	8
DURING OPERATION	9
ROLL-OVER PROTECTIVE STRUCTURE (ROPS) DURING OPERATION....	9
MAINTENANCE.....	10
TRANSPORTING	11
STORAGE	11
OPERATION.....	12
GENERAL PREPARATION.....	12
ENGINE SPEED	12
ENGAGING THE DRIVE MECHANISM	12
MAINTENANCE.....	13
LUBRICATION.....	14
PARTS.....	15
INTRODUCTION	15
ROTO TILLER PARTS AND ASSEMBLY AU-01-1200 REV 2.....	16
HYDRAULIC SCHEMATIC	17
TORQUE SPECIFICATION TABLE.....	18
WARRANTY.....	19

INTRODUCTION

TO THE PURCHASER

All products are designed to give safe, dependable service if they are operated and maintained according to instructions. Read and understand this manual before operation.

This manual has been prepared to assist the owner and operators in the safe operation and suitable maintenance of the equipment. The information was applicable to products at the time of manufacture and does not include modifications made afterwards.

Read and understand this operator's manual before attempting to put equipment into service. Familiarize yourself with the operating instructions and all the safety recommendations contained in this manual and those labeled on the equipment and on the skid steer. Follow the safety recommendations and make sure that those with whom you work follow them.

If you have any questions, see your Accessories Unlimited LLC dealer.

Illustrations

The illustrations may not necessarily reproduce the full detail and the exact shape of the parts or depict the actual models, but are intended for reference only.

Direction Reference

All references to right and left, forward or rearward, are from the operator's seat, facing the steering wheel.

SERIAL PLATE

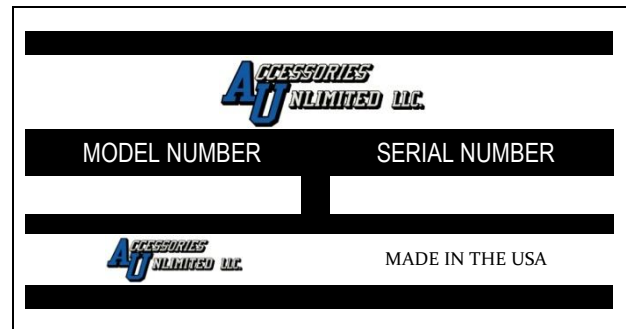

To assist your dealer in handling your needs, please record hereafter the model number and the serial number of your implement and skid steer. It is also advisable to supply them to your insurance company. It will be helpful in the event that an implement or skid steer is lost or stolen.

SKID STEER

IMPLEMENT

MODEL: _____

SERIAL NUMBER: _____

DATE OF PURCHASE: _____

DEALER NAME: _____

SAFETY PRECAUTIONS



SAFETY FIRST

This symbol, the industry's "Safety Alert Symbol", is used throughout this manual and on labels on the machine itself to warn of the possibility of personal injury. This symbol with a warning statement means: "Warning, be alert! Your safety is involved!" Carefully read the message that follows. Warnings on the machine and in the manuals are for your safety. Failure to obey warnings can cause injury or death. It is essential that you read the instructions and safety regulations before you attempt to assemble or use this unit.



DANGER: Indicates an immediate hazardous situation which, if not avoided, will result in death or serious injury. Operator must have instructions before running the machine.



WARNING: Indicates a potentially hazardous situation which, if not avoided, will result in death or serious injury. Operator must have instructions before running the machine.



CAUTION: Indicates a potentially hazardous situation which, if not avoided, may result in minor or moderate injury. Operator must have instructions before running the machine.

IMPORTANT: Indicates that equipment or property damage could result if instructions are not followed. Operator must have instructions before running the machine.

NOTE: Gives helpful information.

All products are designed to give safe, dependable service if they are operated and maintained according to instructions. **Read and understand this manual before operation.** It is the owner's responsibility to be certain anyone operating this product reads this manual, and all other applicable manuals to become familiar with this equipment and all safety precautions. Failure to do so could result in serious personal injury or equipment damage. If you have any questions, consult your dealer.

BEFORE OPERATION

Children

Tragic accidents can occur if the operator is not alert to the presence of children. Children are generally attracted to machines and work being done. Never assume children will remain where you last saw them.

1. Keep children out of the operating area and under the watchful eye of another responsible adult.
2. Be alert and turn machine off if children enter the work area.
3. Before and when backing, look behind for small children.
4. Never carry children while operating the machine. They may fall off and be seriously injured or interfere with the safe operation of the machine.
5. Never allow children to play on the machine or attachment even when they are turned off.
6. Never allow children to operate the machine even under adult supervision.
7. Use extra care when approaching blind corners, shrubs, trees, or other obstructions that might hide children from sight.

SAFETY PRECAUTIONS — CONTINUED

NOTICE

A safe operator is the best assurance against accidents. All operators, no matter how experienced they may be, should read this operator's manual and all other related manuals before attempting to operate the equipment. Please read the following section and pay particular attention to all safety recommendations contained in this manual and those labeled on the equipment and on the skid steer. Safe operation is the operator's responsibility.

The skid steer and attachment must be in good operating condition before use.

Safe Operation Needs a Qualified Operator

For an operator to be qualified, he or she must not use drugs or alcoholic drinks which impair alertness or coordination while working. An operator who is taking prescription drugs must get medical advice to determine if he or she can safely operate a machine.

A QUALIFIED OPERATOR MUST DO THE FOLLOWING:

Understand the Written Instructions, Rules and Regulations

Check the rules and regulations at your location. The rules may include an employer's work safety requirements. Regulations may apply to local driving requirements or use of a Slow Moving Vehicle (SMV) emblem. Regulations may identify a hazard such as a utility line.

Have Training with Actual Operation

1. Operator training must consist of a demonstration and verbal instruction. This training is given by your Accessories Unlimited LLC dealer before the product is delivered.
2. The new operator must start in an area without bystanders and use all the controls until he or she can operate the machine and attachment safely under all conditions of the work area. Always fasten seat belt before operating.

Know the Work Conditions

1. Know the weight of the materials being handled. Avoid exceeding the machine load capacities. Material which is very dense will be heavier than the same volume of less dense material. Reduce the size of the load if handling dense material.
2. The operator must know any prohibited uses or work areas, for example, he or she needs to know about excessive slopes.
3. Know the location of any underground lines; call before you dig. Call local utilities or the North American One Call Referral System at 1-888-258-0808. When you call this number you will be directed to a location in your state/city for information about buried lines (telephone, cable TV, water, sewer, gas, etc.).

SAFETY PRECAUTIONS — CONTINUED

FIRE PREVENTION

The machines and some attachments have components that are at high temperatures under normal operating conditions. The primary source of high temperatures is the engine and exhaust system. The electrical system, if damaged or incorrectly maintained, can be a source of arcs or sparks.

Flammable debris (leaves, straw, etc.) must be removed regularly. If flammable debris is allowed to accumulate, it can cause a fire hazard. Clean often to avoid this accumulation. Flammable debris in the engine compartment is a potential fire hazard.

The spark arrestor exhaust system (if equipped) is designed to control the emission of hot particles from the engine and exhaust system, but the muffler and the exhaust gases are still hot.

1. Do not use the machine where exhaust, arcs, sparks or hot components can contact flammable material, explosive dust or gases.
2. The operator cab (if equipped), engine compartment and engine cooling system must be inspected every day and cleaned if necessary to prevent fire hazards and overheating.
3. Check all electrical wiring and connections for damage. Keep the battery terminals clean and tight. Repair or replace any damaged part.
4. Check fuel and hydraulic tubes, hoses and fittings for damage and leakage. Never use open flame or bare skin to check for leaks. Tighten or replace any parts that show leakage. Always clean fluid spills. Do not use gasoline or diesel fuel for cleaning parts. Use commercial nonflammable solvents.
5. Do not use ether or starting fluids on any engine that has glow plugs. These starting aids can cause explosion and injure you or bystanders.
6. Always clean the machine, disconnect the battery, and disconnect the wiring from the controllers (if equipped) before welding. Cover rubber hoses, battery and all other flammable parts. Keep a fire extinguisher near the machine when welding. Have good ventilation when grinding or welding painted parts. Wear dust mask when grinding painted parts. Toxic dust or gas can be produced.
7. Stop the engine and let it cool before adding fuel. No smoking!
8. Use the procedure in the operator's manual for connecting the battery and for jump starting.
9. Use the procedure in the operator's manual for cleaning the spark arrestor muffler (if equipped).
10. Know where fire extinguishers and first aid kits are located and how to use them. Fire extinguishers are available from your Accessories Unlimited LLC dealer.

SAFETY PRECAUTIONS — CONTINUED

THE ROTO TILLER

Before Operation

1. Read and understand this operator's manual and skid steer operator's manual. Know how to operate all controls and how to stop the unit and disengage the controls quickly.
2. In addition to the design and configuration of equipment, hazard control and accident prevention are dependent upon the awareness, concern, prudence and proper training of personnel involved in the operation, transport, maintenance and storage of equipment.
3. Never wear loose, torn, or bulky clothing around the skid steer and the tiller. It may catch on moving parts or controls, causing injury.
4. Always wear safety glasses when doing maintenance or service.
5. Check for underground lines before operating attachment (if applicable).
6. Before and during the tilling season, thoroughly inspect the area where the equipment is to be used and remove all objects that may cause damage to the equipment.
7. Check that the Bob-Tach levers are in the locked position and the wedges are fully engaged into the holes of the attachment (if applicable).
8. Check that the attachment is securely fastened to the machine.
9. Set transmission to neutral and disengage clutch, if equipped, before starting the engine.
10. Operate the attachment only from the operator's position.
11. When learning to operate the attachment, do it at a slow rate in an area clear of bystanders.
12. Do not permit personnel to be in the work area when operating the machine and attachment.
13. Never attempt to make any adjustments while engine is running. Read this manual carefully to acquaint yourself with the equipment as well as the skid steer operator's manual. Working with unfamiliar equipment can lead to accidents. Be thoroughly familiar with the controls and proper use of the equipment.
14. Keep all safety guards in place and verify hardware for proper tightening.
15. Check for moving parts excessive wear regularly. Replace worn parts with genuine parts.
16. Replace all missing, illegible, or damaged safety and warning decals. See list of decals in operator's manual.
17. Keep safety decals clean of dirt and grime.
18. The attachment must be used ONLY on approved machines. See your Accessories Unlimited LLC dealer for an updated list of approved attachments for each machine model.
19. Do not modify or alter this equipment or any of its components, or any equipment or any of its components, or any equipment function without first consulting your Accessories Unlimited LLC dealer.
20. Use of counterweights is recommended. Weights provide the necessary balance to improve stability, traction and steering. Use only those recommended by your Accessories Unlimited LLC dealer.

SAFETY PRECAUTIONS — CONTINUED

Auxiliary Hydraulic Controls

The auxiliary hydraulics must be activated prior to tiller operation.

Loaders: Enter the loader. Fasten the seat belt, lower the seat bar and start the engine. Release the parking brake.

Utility Work Machine: Enter the cab and fasten the seat belt, lower the operator arm rest, and start the engine. Release the parking brake.

Roto Tiller Operation

NOTE: If the ground is extremely compacted, it may be necessary to make several passes to get to the desired depth.

NOTE: Tilt the tiller forward and make multiple passes with the tiller to dig deeper into the ground.



WARNING: To avoid serious personal injury or death: Bystanders must stay at least 9 ft. (3 m) away from the attachment when operating. DO NOT TOUCH the tiller or leave the loader seat while the engine is running.

1. Tilt the tiller back and move the machine/attachment to the starting point.
2. Tilt the tiller slowly to the ground. Make sure the attachment is level with the ground.
3. The tiller can be operated by moving the machine either forward or backward.
4. Before leaving the skid steer unattended, take all possible precautions. Park the skid steer/tiller on level ground, place the transmission in neutral, set the parking brake, disengage the Aux hydraulics, lower the equipment to the ground, place all levers including auxiliary control levers in neutral, shut off the engine and remove the ignition key.
5. Prior to operation, clear work area of all objects that can be picked up and thrown. Mark all curbs, pipes, etc. that cannot be moved.
6. Be sure the Aux hydraulics switch/lever is in OFF position before starting engine.
7. Exercise extreme caution when operating on or crossing a gravel drive, walks, or roads. Stay alert for hidden hazards or traffic.
8. Do not carry passengers.
9. Keep clear of rotating parts. Do not put hands or feet under or into tiller with engine running, and allow the rotating parts to stop BEFORE unclogging.
10. Park the skid steer/tiller on level ground, place the transmission in neutral, set the parking brake, disengage the Aux hydraulics, lower the equipment to the ground, place all control levers in neutral, shut off the engine, remove the ignition key and allow the rotating parts to stop BEFORE making any repairs, adjustments or inspections.
11. If the tiller starts to vibrate abnormally, disengage the Aux hydraulics, stop the engine immediately and check for cause. Excessive vibration is generally a sign of trouble.
12. Do not run the engine indoors except when starting engine and transporting attachment in or out of building. Carbon monoxide gas is colorless, odorless and deadly.
13. Do not attempt to operate on steep slopes. If operating on slopes is necessary, exercise extreme caution when changing direction.
14. Never operate tiller without guards, and other safety protective devices in place.

SAFETY PRECAUTIONS — CONTINUED

15. Never operate machine at high transport speeds on a slippery surface.
16. Use extra caution when backing up.
17. Never operate the tiller without good visibility and lighting.
18. Prolonged exposure to loud noise can cause impairment or loss of hearing. Wear a suitable hearing device such as earmuffs or earplugs to protect against objectionable or uncomfortable noises.
19. Never allow anyone near the work area.

SAFETY PRECAUTIONS — CONTINUED

THE SKID STEER

General Information

1. Read the operator's manual carefully before using skid steer. Lack of operating knowledge can lead to accidents.
2. Do not permit anyone but the operator to ride on the skid steer. There is no safe place for passengers.

Operating the Skid Steer

1. Never run the skid steer engine in a closed building without adequate ventilation, as the exhaust fumes are very dangerous.
2. Adopt safe driving practice: Keep the parking brake on at all times during transportation.
3. Always drive at a safe speed relative to local conditions and ensure that your speed is low enough for an emergency stop to be safe and secure.
4. Reduce speed prior to turns to avoid the risk of overturning. Keep speed to a minimum.
5. Always keep the skid steer in gear to provide engine braking when going downhill. Do not coast.
6. Never allow an open flame near the fuel tank or battery.
7. Make sure the proper shields are installed when using the equipment and always replace the shields if damaged.
8. Park the skid steer on level ground, place the transmission in neutral, set the parking brake, disengage the Aux hydraulics, lower the equipment to the ground, place all levers including auxiliary control levers in neutral, shut off the engine and remove the ignition key BEFORE leaving the skid steer.
9. Never park the skid steer on a steep slope.
10. Do not attempt to operate on steep slopes. Avoid sudden uphill turns on steep slopes.
11. Use of counterweights for better traction and stability is recommended.
12. Handle fuel with care, as it is highly flammable.
13. Use approved fuel container.
14. Never add fuel to running engine or a hot engine.
15. Fill fuel tank outdoors with extreme care. Never fill fuel tank indoors. Replace fuel cap securely and wipe up spilled fuel.
16. Never allow anyone to operate the tiller until they have read the manual completely and are thoroughly familiar with basic skid steer and tiller operation.
17. Make sure the skid steer is counterweighted as recommended by your dealer. Weights provide the necessary balance to improve stability, traction and steering.
18. Always make sure all tiller components are properly installed and securely fastened BEFORE operation.
19. Never attempt to start the engine and/or engage tiller drive while standing beside the skid steer.
20. Always start the engine from the operator's seat with all the transmission lever(s) and tiller drive lever in neutral.
21. DO NOT bypass the safety system by shorting across the terminals of the starter motor to start the engine. This may cause the skid steer to move suddenly.
22. If the safety start system does not work, consult your dealer immediately.

SAFETY PRECAUTIONS — CONTINUED

During Operation

1. Do not allow passengers on the skid steer/tiller at any time. There is no safe place for passengers on the equipment. The operator **MUST** sit in the skid steer seat.
2. Eye and hearing protection is recommended when operating the tiller.
3. Operate only during daylight hours, or when the area is well lit with bright artificial light.
4. Park the skid steer on level ground, place the transmission in neutral, set the parking brake, disengage the Aux hydraulics, lower the equipment to the ground, place all control levers in neutral, shut off the engine and remove the ignition key **BEFORE** leaving the operator's seat.
5. Inspect the tiller after striking any foreign object to assure that all tiller parts are safe and secure and not damaged.
6. Be especially observant of the operating area and terrain. Watch for holes, rocks, or other hidden hazards. **ALWAYS** inspect the area prior to tilling.
7. **DO NOT** till near the edge of drop-offs or banks.
8. **DO NOT** till on steep slopes as overturn may result.
9. Operate up and down (not across) intermediate slopes. Avoid sudden starts and stops.
10. Drive skid steer backwards up steeper slopes with tiller off. Then till as you travel down the slope.
11. Slow down before you change directions on any slope.
12. Use wheel weights on your skid steer to increase stability on slopes.
13. Never stand alongside of the unit while the engine is running.

Roll-Over Protective Structure (ROPS) During Operation

1. **DO NOT** weld, drill or alter the ROPS. Damaged ROPS must not be straightened or used. If damage does occur, consult your dealer.
2. If ROPS is lowered or removed from the skid steer for any reason, it must be erected and/or refitted immediately. Original bolts or equivalent replacements must be used and tightened to the correct torque.
3. Your dealer does not recommend usage of skid steer with ROPS removed.
4. Seat belt usage: With ROPS installed on the skid steer it is imperative that the seat belt be installed, used and correctly adjusted, at all times. **DO NOT** use a seat belt if operating without ROPS.
5. Keep all shields and covers in place. All skid steer and equipment shields and covers must be correctly installed at all times. When necessary to remove these, they must be reinstalled immediately.
6. Keep clear of all rotating driveline components. Be especially observant of implement areas of discharge, intake or other mechanical motion.
7. Securely lock equipment drive shaft. Check that all skid steer and equipment drivelines are in good working order.
8. Additional safety equipment: A fire extinguisher and first aid kit should be kept readily accessible. These are available through your dealer.

SAFETY PRECAUTIONS — CONTINUED

MAINTENANCE

Always use genuine parts when replacement parts are required during operation.

1. Keep the skid steer and tiller properly maintained.
2. Park the skid steer on level ground, place the transmission in neutral, set the parking brake, disengage the Aux hydraulics, lower the equipment to the ground, place all control levers in neutral, shut off the engine and remove the ignition key and allow the rotating parts to stop BEFORE making any tiller adjustments.
3. To avoid injury, do not adjust, unclog or service the tiller with the skid steer engine running. Make sure rotating components have completely stopped before leaving the operator's seat.
4. Keep the skid steer/tiller clean.
5. Always wear eye protection when cleaning or servicing the tiller.
6. Service the unit in safety: DO NOT service the skid steer while the engine is running or hot, or if the unit is in motion. Always lower tiller to the ground. If necessary to service unit with tiller raised, securely support with stands or suitable blocking before working underneath. Do not rely on hydraulically supported devices for your safety. They can settle suddenly, leak down, or be accidentally lowered.
7. Do not attempt to service machine, clear obstructions or unplug blockages with the engine running. Always shut off engine and allow all motion to cease.
8. The manufacturer will not claim responsibility for fitment of unapproved parts and/or accessories and any damages as a result of their use.
9. Make sure all shields and guards are securely in place following all service, cleaning, or repair work.
10. Do not modify or alter this equipment or any of its components or operating functions. If you have any questions concerning modifications, consult with your dealer.
11. Do not operate a unit which is defective or has missing parts. Make sure that all recommended maintenance procedures are completed before operating the unit.
12. Check all controls regularly and adjust where necessary.
13. Periodically check all nuts and bolts for tightness, especially wheel hub and rim nuts.
14. Tiller teeth must be checked for tightness. Remove any twine, wire, etc. that may have gotten wrapped in the tiller teeth.
15. To avoid serious personal injury: Escaping hydraulic/diesel fluid under pressure can penetrate the skin causing serious injuries. Do not use your hands to check for leaks. Use a piece of cardboard or paper to search for leaks.
16. Stop engine and relieve pressure before connecting lines. Tighten all connections before starting engine or pressurizing lines.

SAFETY PRECAUTIONS — CONTINUED

TRANSPORTING

1. Transporting on public roadway: When driving the skid steer and equipment on the road or highway under 25 mph, at night or during the day, use flashing amber warning lights and the Slow Moving Vehicle ("SMV") identification emblem.
2. Check local traffic codes that may apply to unit usage on public roads and highways in your area. The use of flashing amber lights is acceptable in most localities. However, some localities may prohibit their use.
3. Always disengage equipment drive prior to transporting unit.

STORAGE

Before storing the tiller, certain precautions should be taken to protect it from deterioration.

1. Clean the tiller throughout.
2. Make all the necessary repairs.
3. Replace all safety signs that are damaged, lost, or otherwise become illegible. If a part to be replaced has a sign on it, obtain a new safety sign from your dealer and install it in the same place as on the removed part.
4. Repaint all parts from which paint has worn or peeled.
5. Lubricate the tiller as instructed under the "Lubrication" section.
6. When the tiller is dry, oil all moving parts. Apply oil liberally to all surfaces to protect against rust.
7. Store in a dry place.

OPERATION

GENERAL PREPARATION

1. Read the operator's manual carefully before using the skid steer and tiller. Be thoroughly familiar with the controls and proper use of the equipment. Know how to stop the unit and disengage the controls quickly.
2. Wear adequate outer garments while operating the equipment.
3. Make sure the tiller is clear of dirt and other material before engaging the tiller.
4. Before engaging the tiller drive, always have the engine running at idle.
5. Operate the tiller at maximum to 3/4 engine RPM.

Engine Speed

1. Start the skid steer engine. Let the engine warm up at least one minute before engaging the drive mechanism then increase speed gradually.
2. Make sure the tiller is properly positioned and engage the drive mechanism.
3. Adjust the ground speed according to conditions. For maximum power, run engine at or near full throttle.

IMPORTANT: Use full RPM power when tilling. Low RPM power will tend to clog the teeth.



WARNING: To avoid serious personal injury: Do not use your hands to unclog the tiller shaft. Use a 36" (925mm) stick or board. Do not attempt to unclog the chute while engine is running. If the chute is clogged, shut off the skid steer engine, remove the key and allow the rotating parts to stop before removing any objects.

Engaging the Drive Mechanism

Refer to the skid steer's operating manual for instructions.



WARNING: To avoid serious personal injury: Make sure skid steer engine and tiller come to a complete stop and skid steer drive mechanism is disengaged BEFORE making any adjustments.

MAINTENANCE

Always use genuine parts when replacement parts are required.



WARNING: To avoid serious personal injury:

- Before cleaning, adjusting or repairing the tiller: Bring the skid steer to a complete stop, disengage the Aux hydraulics, apply parking brake, lower the implement to the ground, shut off the engine and remove the ignition key.
- Never park the skid steer inside a building where an open flame or sparks are present. Allow the engine to cool down before storing in any enclosure.
- Run the tiller a few minutes after tilling to remove any built up dirt.
- Provide adequate blocking before working under the tiller when in raised position.

MAINTENANCE — CONTINUED

LUBRICATION

Use oil or grease gun and lubricate as follows:

DESCRIPTION	INTERVAL	LUBRICATION REQUIRED
Bearing	8 hours of operation	Grease each auger bearing.
Driving Chain	4 hours and after each operation	Lubricate with chain lube.

PARTS

INTRODUCTION

All parts are illustrated in "exploded views" which show the individual parts in the normal relationship to each other. Reference numbers are used in the illustrations. These numbers correspond to those in the "*Item No.*" column, and are followed by the description and quantity required.

The manufacturer reserves the right to change, modify, or eliminate from time to time, for technical or other reasons, certain or all data, specifications, or the product or products themselves, without any liability or obligation.

PARTS — CONTINUED

ROTO TILLER PARTS AND ASSEMBLY

AU-01-1200 REV 2

ITEM NO.	PART NUMBER	DESCRIPTION	QTY.
1	AU-02-1511-Width	Tiller Shaft	1
2	AU-03-1625	1.750 Flange Bearing	2
3	AU-02-1512	Chain Gaurd	1
4	AU-03-1605	Access Cover	1
5	AU-03-1617	Cover Plate	1
6	AU-03-1620	L.H. Tiller Tine	14
7	AU-03-1621	R.H. Tiller Tine	14
8	AU-02-1513-Width	Tiller Body	1
9	AU-03-4005	80H 9 Tooth Sprocket	1
10	AU-03-4006	80H 22 Tooth Sprocket	1
11	AU-03-9910	Hydraulic Motor	1
12	AU-03-1626	.375 X 1.50 Key	1
13	AU-03-1635	80H X 45.00 Chain	1
14	H500-7200KK	1/2 in X 72.00 Hydraulic hose	2
15	HSL500-66	66" Hose sleeve	1
16	H500-FT11	7/8 Male ORB TO 1/2 NPT Female Swivel Fitting	2

Wearable Item

Wearable Item

Wearable Item

Wearable Item

- A - Blade Warning Decal
- B - Rotating Machinery Warning Decal
- C - Accessories Unlimited Contact Info Decal
- D - Accessories Unlimited Logo Decal(Large)
- E - Grease Dait Decal
- F - Caution "Do Not Operate With Gaurd Removed Decal
- G - Model Serial# Decal

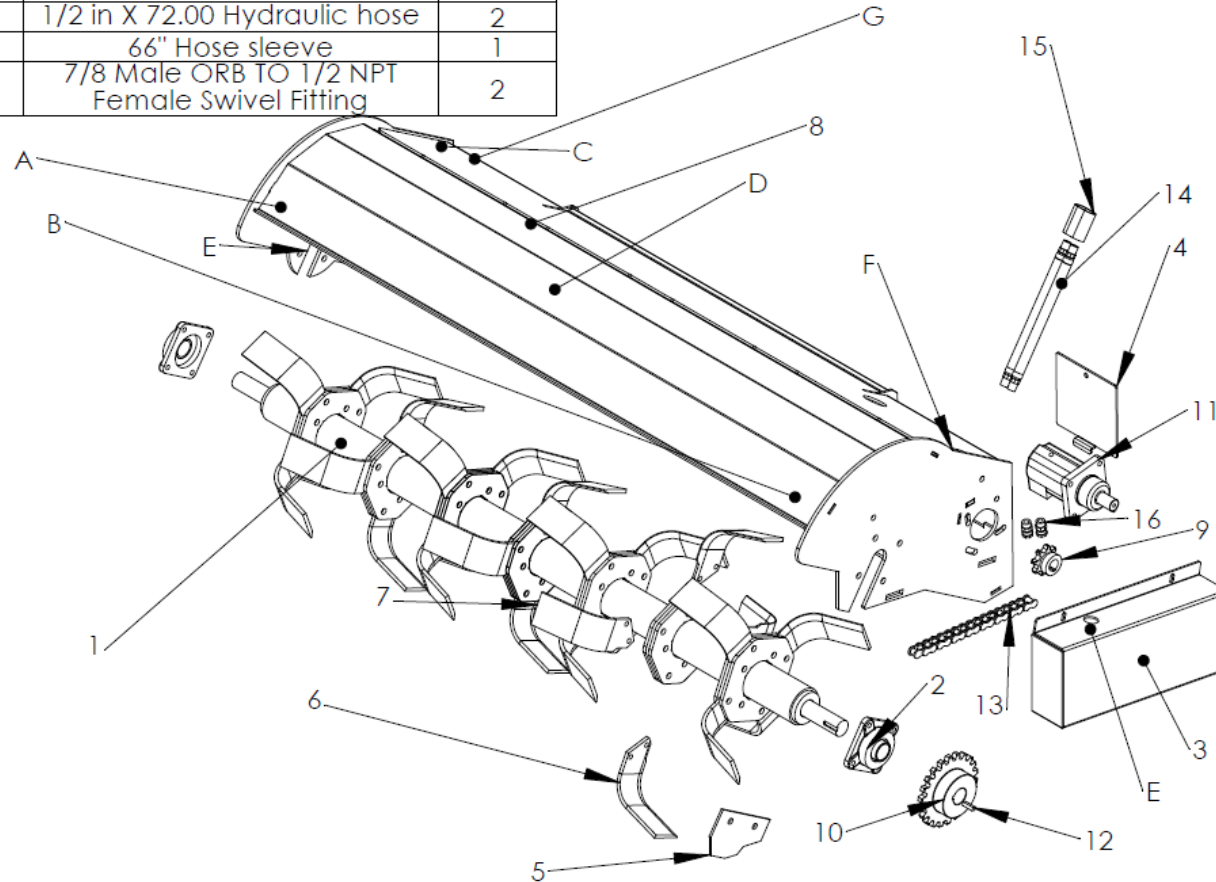

PARTS — CONTINUED

HYDRAULIC SCHEMATIC

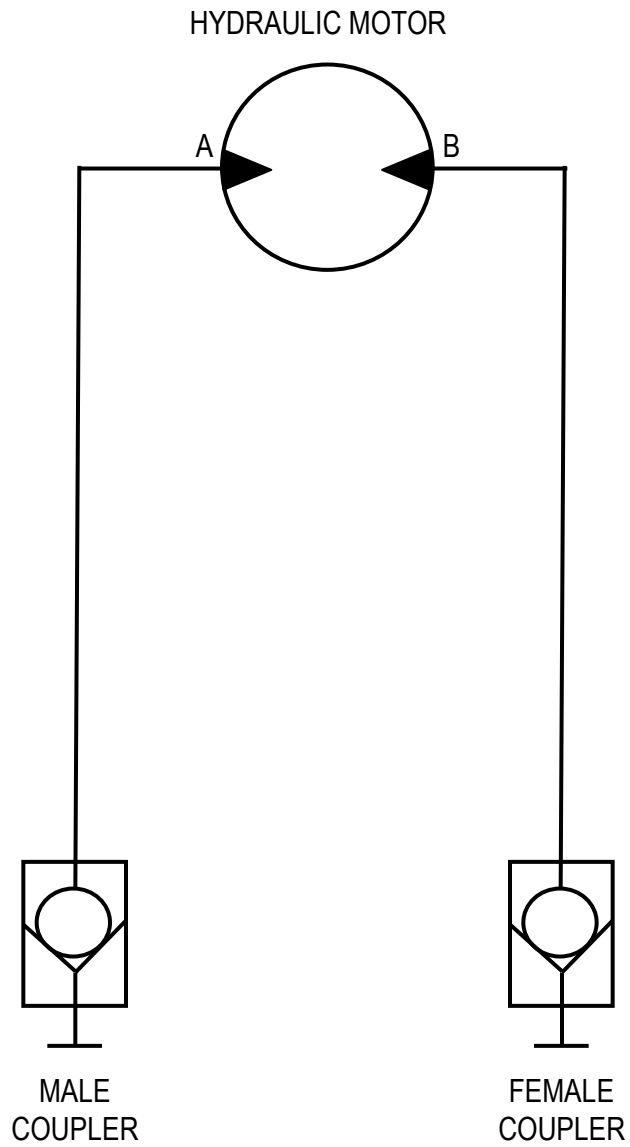

TORQUE SPECIFICATION TABLE

GENERAL SPECIFICATION TABLE

Use the following torques when special torques are not given. Note: These values apply to fasteners as received from supplier, when dry. These values do not apply if lubricants are used.

BOLT SIZES (SAE)	TORQUE	
INCHES	POUNDS-FOOT	NEWTONS-METER
1/4	5	7
5/16	10	14
3/8	20	27
7/16	25	41
1/2	88	119
9/16	121	164
5/8	165	224
3/4	297	403
7/8	440	597
1	638	865
1 1/8	840	1139
1 1/4	1180	1600
1 3/8	1570	2129
1 1/2	2070	2807

BOLT SIZES (METRIC)	TORQUE	
MILLIMETERS	POUNDS-FOOT	NEWTONS-METER
M6	10	13
M8	22	30
M10	40	54
M12	59	80
M14	93	126
M16	130	176
M18	168	228
M20	205	278

WARRANTY

ACCESSORIES UNLIMITED LLC ATTACHMENTS

Accessories Unlimited LLC warrants to its authorized dealers who in turn warrant to the original owner, that each new Accessories Unlimited LLC attachment will be free from proven defects in material and workmanship for twelve (12) months after delivery by the authorized Accessories Unlimited LLC dealer to the original buyer.

During the warranty period, the authorized Accessories Unlimited LLC dealer shall repair or replace, at Accessories Unlimited LLC's option, without charge for parts and labor, any part of the Accessories Unlimited LLC product which fails because of defects in material or workmanship. The owner shall provide the authorized Accessories Unlimited LLC dealer with prompt written notice of the defect and allow reasonable time for replacement or repair. Accessories Unlimited LLC may, at its option, require failed parts to be returned to the factory. Travel time of mechanics and transportation of the Accessories Unlimited LLC product to the authorized Accessories Unlimited LLC dealer for warranty work are the responsibility of the owner. The remedies provided in this warranty are exclusive.

This warranty does not cover replacement of scheduled service items and high wear items. The owner shall rely solely on the warranty, if any, of the respective manufacturers thereof. This warranty does not cover damages resulting from abuse, accidents, alterations, use of the Accessories Unlimited LLC product as an attachment on any equipment not approved by Accessories Unlimited LLC, air flow obstructions, or failure to maintain or use the Accessories Unlimited LLC product according to the instructions applicable to it.

THIS WARRANTY IS EXCLUSIVE AND IN LIEU OF ALL OTHER WARRANTIES AND CONDITIONS, EXCEPT THE WARRANTY OF TITLE, ACCESSORIES UNLIMITED LLC DISCLAIMS ALL OTHER WARRANTIES AND CONDITIONS, EXPRESS OR IMPLIED, INCLUDING ANY IMPLIED WARRANTIES OR CONDITIONS OF MERCHANTABILITY OR FITNESS FOR A PARTICULAR PURPOSE. IN NO EVENT SHALL ACCESSORIES UNLIMITED LLC OR THE AUTHORIZED ACCESSORIES UNLIMITED LLC DEALER BE LIABLE FOR ANY SPECIAL, INCIDENTAL, INDIRECT OR CONSEQUENTIAL DAMAGES, WHATSOEVER, INCLUDING, BUT NOT LIMITED TO, LOSS OR INTERRUPTION OF BUSINESS, LOST PROFITS, OR LOSS OF MACHINE USE, WHETHER BASED ON CONTRACT, WARRANTY, TORT, NEGLIGENCE, STRICT LIABILITY, STATUTE OR OTHERWISE, EVEN IF ACCESSORIES UNLIMITED LLC OR THE AUTHORIZED ACCESSORIES UNLIMITED LLC DEALER HAS BEEN ADVISED OF THE POSSIBILITY OF SUCH DAMAGES. THE TOTAL LIABILITY OF ACCESSORIES UNLIMITED LLC AND THE AUTHORIZED ACCESSORIES UNLIMITED LLC DEALERS WITH RESPECT TO THE PRODUCT AND SERVICES FURNISHED HEREUNDER SHALL NOT EXCEED THE PURCHASE PRICE OF THE PRODUCT UPON WHICH SUCH LIABILITY IS BASED.



OPERATOR'S MANUAL
ACCESSORIES UNLIMITED ROTO TILLER

MADE IN THE USA