

# C16 1000

## Marine Pleasure / Commercial CURSOR 16

Rating type A2: 735 kW (1000 HP) @ 2300 rpm

Rating type . : 662 kW (900 HP) @ 2300 rpm

Rating type C: 599 kW (815 HP) @ 2300 rpm

Rating type C: 552 kW (750 HP) @ 2300 rpm

Rating type C: 478 kW (650 HP) @ 2300 rpm

### SPECIFICATIONS

Thermodynamic cycle	Diesel 4 stroke	
Air handling	TCA	
Cylinders arrangement	6L	
Bore x Stroke	millimeters	141 x 170
Total displacement	liters	15.9
Valves per cylinder	number	-
Cooling System	-	
Direction of Rotation (viewed facing flywheel)	CCW	
Engine management	by ECU (Electronic Control Unit)	
Injection System	CR (Common Rail)	

### STANDARD CONFIGURATION

Flywheel housing	type	SAE 1
Flywheel size	inch	14"
Air filter	rear side	
Turbocharger	iate Single Stage (water cooled) Turbo with Aftercooler (TCA)	
Heat exchanger	tube type	
Exhaust gas water mixer - Exhaust cooled elbow	-	
Water charge tank	included	
Fuel filter	number	1 Rear Side
Fuel prefilter	included (loose)	
Fuel pump	included	
Oil filter	number	2 Left Side
Oil sump	aluminium	
Oil vapours blowby circuit	rear	
Oil heat exchanger	included	
Oil filler	by cylinder head cover	
Starter	24 V - 5.5 kW	
Alternator	28 V - 120 A	
Engine stop device	by ECU (Electronic Control Unit)	
Wiring harness	with negative to ground connection	
Painting color	white "ICE"	

### WEIGHT AND DIMENSIONS

Dimensions	LxWxH (inch)	see below
Dry Weight	lbs	3,726



MARINE

### ELECTRICAL SYSTEM

Voltage	V	24 V
---------	---	------

### NOT INCLUDED IN STANDARD CONFIGURATION

Battery - minimum capacity recommended	Ah	120 Ah
Battery - minimum cold cranking capacity recommended	Ah	900 Ah

### LEGEND

Arrangement	Air Handling	Turbocharger	Injection System	Exhaust System
L (in line)	TCA (Turbocharged with aftercooler)	WG (Wastegate)	M (Mechanical)	EGR (Exhaust Gas Recirculation)
V (90° "V" configuration)	TC (Turbocharged)	VG (Variable Geometry Turbocharger)	ECR (Electronic Common Rail)	SCR (Selective Catalytic Reduction)
	NA (Naturally Aspirated)	TST (Twin Stage Turbocharger)	EUI (Electronic Unit Injector)	
			MPI (Multi Point Injection)	

**A1** High Performance Crafts. Full throttle operation restricted within 10% of total use period. Cruising speed at engine rpm <90% of rated speed setting - Maximum usage 300 hours per year.

**A2** Pleasure Commercial Vessels. Full throttle operation restricted within 10% of total use period. Cruising speed at engine rpm <90% of rated speed setting - Maximum usage 1000 hours per year.

**B** Light Duty: Full throttle operation restricted within 10% of use period. Cruising speed at engine rpm <90% of rated speed setting - Maximum usage 1500 hours per year.

**C** Medium Duty: Full throttle operation < 25% of use period. Cruising speed at engine rpm <90% of rated speed setting - Maximum usage 3000 hours per year.

**D** Heavy Duty

FOR INFORMATION ON THE AVAILABLE RATINGS NOT LISTED IN THIS DOCUMENT PLEASE CONTACT THE FPT INDUSTRIAL SALES NETWORK OR VISIT OUR SITE [WWW.FPTINDUSTRIAL.COM](http://WWW.FPTINDUSTRIAL.COM)

SPECIFICATION SUBJECT TO CHANGE WITHOUT NOTICE



## RATING TYPE

		A1	A2	B	C	C	C
Maximum power [*]	kW (HP)	- (-)	735 (1000)	622 (900)	599 (815)	552 (750)	478 (650)
At speed	rpm	-	2300	2300	2300	2300	2300

## POWER & TORQUE

## PANEL SELECTION

FPT C16-1000 Performance Curves (735kW / 1000mhp @ 2300rpm)								
RPM	Power (kW)	Power (mhp)	Propeller (kW)	Propeller (mhp)	Torque (NM)	Torque (lbs)	Fuel Burn (l/h)	Fuel Burn (gal/h)
2300	735	999	735	999	3052	2251	200	53
2200	734	998	643	875	3186	2350	172	45
2100	726	987	559	761	3302	2435	146	39
2000	717	975	483	657	3424	2525	123	33
1900	698	949	414	563	3508	2587	103	27
1800	662	900	352	479	3510	2589	86	23
1700	625	850	297	404	3510	2589	72	19
1600	562	764	247	336	3354	2474	61	16
1500	497	676	204	277	3164	2334	50	13
1400	433	589	166	225	2954	2179	42	11
1300	357	485	133	180	2623	1935	36	9
1200	292	397	104	142	2324	1714	29	8
1100	229	311	80	109	1988	1466	23	6
1000	178	242	60	82	1700	1254	17	4
900	143	194	44	60	1517	1119	12	3
800	112	152	31	42	1337	986	8	2
700	91	124	21	28	1242	916	5	1
600	71	97	13	18	1130	833	3	1

Performance data is not binding and according to their respective tolerances.

FPT C16-1000 Performance Curves (599kW / 815mhp @ 2300rpm)								
RPM	Power (kW)	Power (mhp)	Propeller (kW)	Propeller (mhp)	Torque (NM)	Torque (lbs)	Fuel Burn (l/h)	Fuel Burn (gal/h)
2300	599	814	599	814	2847	2100	165	44
2200	594	808	524	713	2579	1902	145	38
2100	594	808	456	620	2701	1992	125	33
2000	593	806	394	535	2832	2089	104	28
1900	593	806	338	459	2981	2199	85	22
1800	592	805	287	390	3141	2317	70	19
1700	591	804	242	329	3320	2449	58	15
1600	562	764	202	274	3354	2474	49	13
1500	497	676	166	226	3164	2334	41	11
1400	433	589	135	184	2954	2179	34	9
1300	357	485	108	147	2623	1935	29	8
1200	292	397	85	116	2324	1714	23	6
1100	229	311	66	89	1988	1466	18	5
1000	178	242	49	67	1700	1254	14	4
900	143	194	36	49	1517	1119	10	3
800	112	152	25	34	1337	986	7	2
700	91	124	17	23	1242	916	4	1
600	71	97	11	14	1130	833	3	1

Performance data is not binding and according to their respective tolerances.

Digital Deluxe Plus 7"



Digital Compact 5"



MARINE

## DIMENSIONS

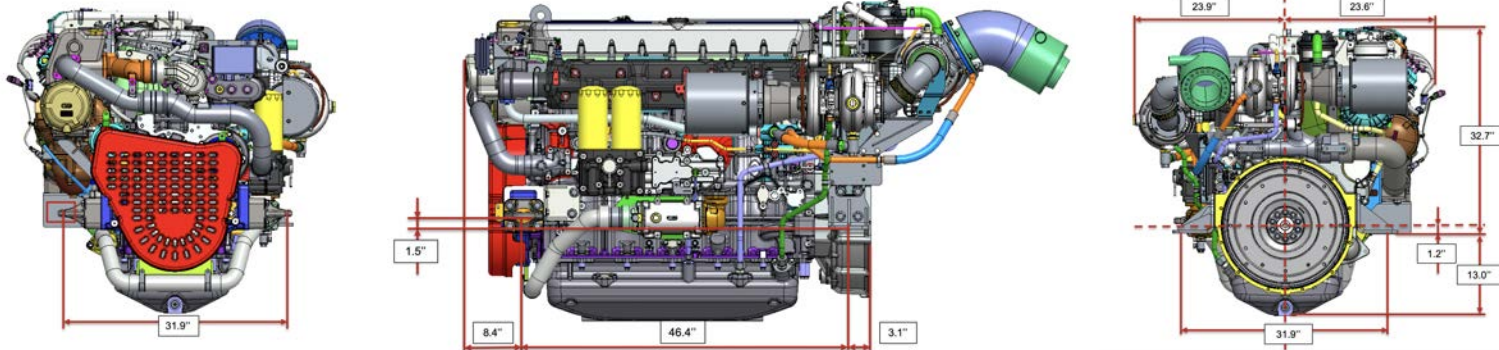

## LEGEND

<b>Arrangement</b>	<b>Air Handling</b>	<b>Turbocharger</b>	<b>Injection System</b>	<b>Exhaust System</b>
L (in line)	TCA (Turbocharged with aftercooler)	WG (Wastegate)	M (Mechanical)	EGR (Exhaust Gas Recirculation)
V (90° "V" configuration)	TC (Turbocharged)	VGT (Variable Geometry Turbocharger)	ECR (Electronic Common Rail)	SCR (Selective Catalytic Reduction)
	NA (Naturally Aspirated)	TST (Twin Stage Turbocharger)	EUI (Electronic Unit Injector)	
			MPI (Multi Point Injection)	

**A1** High Performance Crafts. Full throttle operation restricted within 10% of total use period. Cruising speed at engine rpm <90% of rated speed setting - Maximum usage 300 hours per year.  
**A2** Pleasure Commercial Vessels. Full throttle operation restricted within 10% of total use period. Cruising speed at engine rpm <90% of rated speed setting - Maximum usage 1000 hours per year.  
**B** Light Duty: Full throttle operation restricted within 10% of use period. Cruising speed at engine rpm <90% of rated speed setting - Maximum usage 1500 hours per year.  
**C** Medium Duty: Full throttle operation < 25% of use period. Cruising speed at engine rpm <90% of rated speed setting - Maximum usage 3000 hours per year.  
**D** Heavy Duty

FOR INFORMATION ON THE AVAILABLE RATINGS NOT LISTED IN THIS DOCUMENT PLEASE CONTACT THE FPT INDUSTRIAL SALES NETWORK OR VISIT OUR SITE [WWW.FPTINDUSTRIAL.COM](http://WWW.FPTINDUSTRIAL.COM)

SPECIFICATION SUBJECT TO CHANGE WITHOUT NOTICE

