

CLINICS BC ASSOCIATION

4TH ANNUAL
A VERY VALUABLE SERVICE
CONFERENCE

SPONSOR &
EXHIBITOR
PROSPECTUS

FRIDAY, OCTOBER 18, 2019
PINNACLE HOTEL HARBOURFRONT
1133 W Hastings Street, Vancouver, BC

www.clinicsbc.org

Who we are:

Clinics BC is an association of Medical Clinic Operators (Clinic Owners, Clinic Managers); Physicians; Business Partners and Medical Students.

Clinics BC represents the unique operating interests of medical clinics in the Province of B.C.

We recognize the opportunities and challenges that clinic operators and medical staff working in clinics face on a daily basis and serve as a connection point for clinics to advocate to government and to link clinics with industry trade partners.

Who should attend:

Any business that sells products or services to clinics in the Province of B.C. or any business that relies on referrals from clinics are ideal exhibitors and sponsors at our conference.

Why you should attend:

We offer key access to clinic owners, managers, and physician from across B.C. to connect you with the clinic decision makers who need your products and services.

This is our 4th Annual Conference. In past years we've had between 150-200 attendees. We anticipate an even larger audience this year.

This year, we are offering more time in our program for exhibit/attendee interaction, with specific activities to engage with attendees.

Program-At-A-Glance:

Clinics BC is delighted to have your company participate in our annual conference on October 18, 2019 at the Vancouver Pinnacle Harbourfront Hotel.

This Prospectus should provide you with all the necessary information to make your participation a successful one. Should you have any questions about our event, please contact:

Kristy Fredericks
Conference Services
MCBC
Tel: (604) 626-1374
Email: conferenceservices@compositepublicaffairs.ca

Important Documents:

Once you have reviewed the prospectus and filled in the Sponsorship/ Exhibitor Registration Form please return the form via email to Kristy Fredericks at conferenceservices@compositepublicaffairs.ca as soon as possible to assure your booth location preference.

Additionally, please refer to the Trade Show Check list to ensure that you have completed all required deadlines.

Sponsorship Benefits:

Sponsors of the event have identified 'Keys to the Conference' which entitles them to attend the entire conference including the post-conference reception. This event is limited to delegates and sponsors only. No additional tickets can be purchased for this event.

Additionally, the Sponsorship 'Keys to the Conference' includes the provision of an attendees list of all conference attendees - to be provided within one week of the conclusion of the conference.

Finally, only Sponsors will be entitled to have a booth door prize.

Information for all Business Partners:

The conference will be held on Friday, October 18, 2019. Booth setup begins promptly at 6:00 AM on Friday, October 18, 2019 and all booths **must** be setup by no later than 8:30 AM.

Booth Door Prizes

Only Sponsors are entitled to have booth door prizes. Draws for sponsors' booth door prizes will be drawn during the afternoon coffee break. Each sponsor will be provided an opportunity on stage to draw for their door prize.

Silent Auction

All Sponsors and Exhibitors are required to provide a prize to a silent auction that will take place during the course of the day of the conference. Proceeds from the silent auction will be going to the Canadian Mental Health Association.

Schedule of Event

A full conference schedule will be published on the conference website clinicsbc.org

Attendee Badges

Business Partners attending the conference are required to wear their name badge provided by Clinics BC during all portions of the conference. Name badges will be provided in the conference package that Business Partners will receive upon check-in on the morning of the conference.

Business Partners are asked to provide the names of attendees no later than Friday, October 4, 2019.

Booth Policy:

Your exhibit space must adhere to the guidelines provided in the Sponsorship/Exhibitor descriptions. Please note: Clinics BC reserves the right to decline or prohibit any exhibit or participant that is not keeping within the stated guidelines, as determined by Clinics BC.

Each booth must operate as a separate entity as registered with Clinics BC. The booths design cannot be combined, modified or any part of it removed or changed unless permitted by Clinics BC. No holes may be drilled, nails driven, hooks, screws or similar items tacked into any part of the facility or its equipment. Masking, packing or any other tape is prohibited from being attached to the exhibit floor or walls and no items may be hung from the ceilings or any of its fixtures. There is no smoking permitted anywhere within the facility.

Location of Conference & Space Allocation

The conference is being held in the Harbourside Ballroom and adjoining foyer. Allocation of booths is based on the level of sponsorship and the order in which registration and payment is received and accepted. Business Partners will be contacted once payment has been received to discuss booth location preference, based on availability.

Cancellation of Space

If a Business Partner cancels their Sponsorship/Exhibitorship up to and including Friday, September 15, 2019, Clinics BC will refund monies paid less a 25% administration fee.

No refunds will be made for cancellations received after Friday, September 15, 2019.

Sponsor/Exhibitor Directory

Clinics BC will be providing conference attendees with a directory of all Sponsors and Exhibitors including the Company Name, Contact Person, Address, Phone Number, Email, Website and a short description of the company.

Attendee List

Clinics BC will be providing conference attendees with a directory of all Sponsors and Exhibitors including the Company Name, Contact Person, Address, Phone Number, Email, Website and a short description of the company.

Sponsorship Opportunities

Platinum Sponsor (Reception Sponsorship): \$7,500

Includes:

(1) Ballroom Exterior Wall Booth & 8 'Keys to the Conference' Passes
Full-Page Colour Advertisement in the Conference Program
Full Company Signage During Reception and Conference Recognition
Conference Keynote Speaking Opportunity
Company Logo on website
Opportunity to provide booth door-prize - company representative will have dedicated time to draw and present door-prize to winner.
One-Year Membership in MCBC

Gold Sponsor (Lunch Sponsorship): \$5,000

Includes:

(1) Ballroom Exterior Wall Booth & 6 'Keys to the Conference' Passes
Half-Page Colour Advertisement in the Conference Program
Full Company Signage During Lunch and Conference Recognition
Conference Panelist Participation (1 speaker from company)
Company Logo on website
Opportunity to provide booth door-prize - company representative will have dedicated time to draw and present door-prize to winner.
One-Year Membership in MCBC

Silver Sponsor (Breakfast Sponsorship): \$3,500

Includes:

(1) Ballroom Exterior Wall Booth & 4 'Keys to the Conference' Passes
Half-Page Colour Advertisement in the Conference Program
Full Company Signage During Breakfast and Conference Recognition
Conference Panelist Participation (1 speaker from company)
Company Logo on website
Opportunity to provide booth door-prize - company representative will have dedicated time to draw and present door-prize to winner.
One-Year Membership in MCBC

Bronze Sponsor (Coffee Break Sponsorship - 2 available): \$2,500/each

Includes:

(1) Ballroom Exterior Wall Booth & 4 'Keys to the Conference' Passes
Quarter-Page Colour Advertisement in the Conference Program
Full Company Signage During AM or PM Break and Conference Recognition
Company Logo on website
Opportunity to provide booth door-prize - company representative will have dedicated time to draw and present door-prize to winner.
One-Year Membership in MCBC

*** Please refer to Sponsor & Exhibitor Rules on the next page**

Exhibitor Opportunities

Ballroom - Exterior Wall Booths (16 Available): \$1,500/each

Includes:

(1) Ballroom Exterior Wall Booth (approx. 8' W with 6' W table and 2 chairs)
Ability to have proper 'back-drop' booth banner or larger pop-up banners
2 Attendee Passes
Company Logo (Full-Colour) in the Conference Program
Company Logo on website
One-Year Membership in MCBC

Ballroom - Interior Exhibit Tables (20 Available): \$975/each

Limited to 1 small pop-up banner only, **no 'back-drop' booth banners allowed

Includes:

6' Table top booth with 2 chairs
2 Attendee Passes
Company Logo (Full-Colour) in the Conference Program
Company Logo on website
One-Year Membership in MCBC

Foyer - Exhibit Tables (5 Available): \$675/each

Limited to 1 small pop-up banner only, **no back-drop booth banners allowed

Includes:

6' Table top booth with 2 chairs
1 Attendee Passes
Company Logo (Full-Colour) in the Conference Program
Company Logo on website
One-Year Membership in MCBC

Sponsor & Exhibitor Rules

Please Note:

SETUP TIME STARTS: 6:00 AM on October 18, please have your booth fully set-up by 8:30 AM

- * Power access must be ordered from the hotel directly (prior to the day of the event) - see attached order form.
- ** For all shipping guidelines, please refer to the attached shipping policies document from the hotel.
- *** Wifi will be available, if you require wired access please order from the hotel prior to the event.
- **** Parking is at your own cost, please refer to parking rates in the attached document.
- ***** Meals: Sponsors and exhibitors are welcome to participate in all meals and breaks.
- ***** No wall hangings are permitted, all banners/posters must be stand-alone.

Pre-Conference Opportunities:

This year we are pleased to offer 4 half-day (four hour) session opportunities (on Thursday, October 17) for exhibitors to host in-depth user experiences with attendees. *****You must be registered as either a Sponsor or Exhibitor on October 18 in order to participate in the pre-conference day.**

These sessions are optional for attendees and pre-registration will be required by attendees.

These session could be used for:

- In-depth software experiences and training
- Retail information sessions for potential clinics
- Demonstrations of services and equipment

Pre-Conference Half-Day Exhibitor Session - Thursday, October 17, 2019

Price starts at \$500.00

4 Session Spots Available:

(2 Spots Available - Separate Rooms) 8:00 AM - 12:00 PM or

(2 Spots Available - Separate Rooms) 1:00 PM - 5:00 PM

Includes:

Private room for up to 50 attendees with classroom-style set-up

Coffee & Water Service

Promotion and registration administration by MCBC

**Note all AV requirements are the exhibitor's responsibility and require prior booking directly with the hotel.

Silent Auction:

This year as part of the conference program we will be hosting a silent auction with proceeds going to the Canadian Mental Health Association.

Sponsors/exhibitors are asked to bring an item to be included in the silent auction.

Signage with your logo recognizing your contribution will be on-site to be placed next to your item. Additionally, when the highest bidders are announced, each company will be recognized verbally by the Master of Ceremonies.

Conference Maps

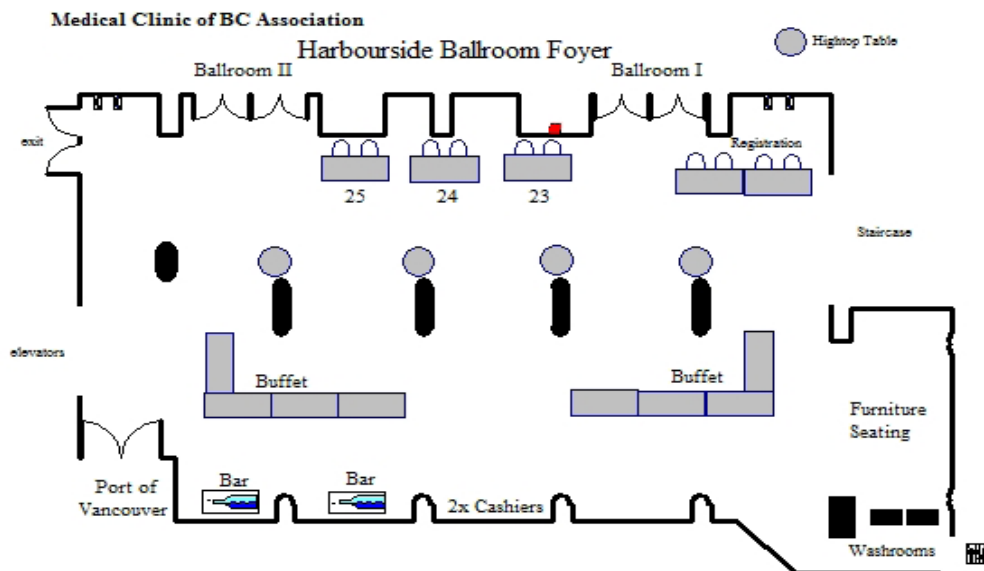
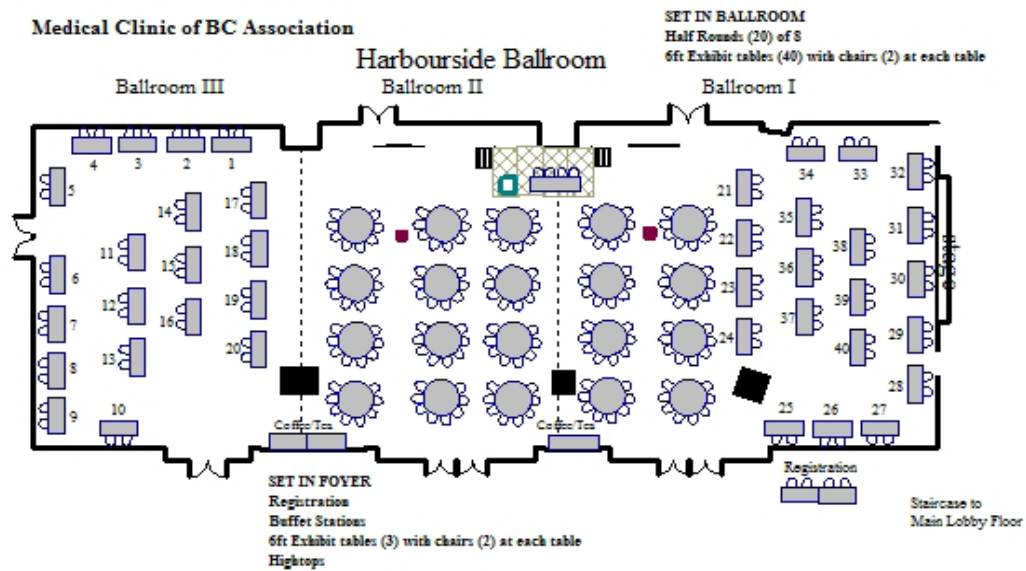

Sponsorship/Exhibitor Registration

**4th A Very Valuable Service Conference –
Friday, October 18th, 2019 - 8:30 AM- 5:00 PM**

**Pinnacle Hotel Harbourfront
1133 W Hastings St, Vancouver, BC V6E 3T3**

2019 Conference Registration Form

Company Name: _____ **Ph#:** _____

Address: _____

City: _____ **Prov.** _____ **Postal Code:** _____

Attendee Name(s)*: (For Name Badges *for Sponsorships please use separate sheet for additional names)

Name: _____ **Title:** _____ **Email:** _____

Name: _____ **Title:** _____ **Email:** _____

Sponsorship (please specify option): _____

(or)

Exhibitor (please specify option): _____

Payment Info:

Cheque (payable to **Clinics BC** and mail to 101-1865 Dilworth Dr. Kelowna, BC Canada V1Y 9T1)

Credit Card

First Name: _____ **Last Name:** _____ **Ph. #:** _____

Visa/Mastercard #: _____ **Expiry (mm/yy):** _____ **CVV:** _____

Total Amount Due: \$ _____

Please email completed form to Kristy Fredericks: conferenceservices@compositopublicaffairs.ca.

Send cheques to: Clinics BC, 324, 101-1865 Dilworth Dr. Kelowna, BC Canada V1Y 9T1

Please Note: Exhibit locations will be assigned on a first-come, first served basis once payment is received. Exhibit location will be at the discretion of the Association unless otherwise agreed.

SPONSOR/EXHIBITOR CHECKLIST (Please complete this list upon your registration confirmation)

___ Full-Colour logo - three sizes for logo, (small, medium, large) max file size 20mb.

___ Max. 50 word description of company.

___ For Sponsors Only - Copy of advertisement.

___ Read through the exhibitor rules/shipping information.

___ Order any required power/AV directly from hotel.

___ All Sponsors & Exhibitors - Item for silent auction.

___ For Sponsors Only - Booth door prize.

AV & Power Order Form



Dear Exhibitor,

This form has been created in order to allow you to order exhibit related equipment & charge them to your credit card. Please provide all the information requested below to ensure prompt processing of your application. We ask you to please sign and date the form before submission. Please email the completed form to lcchang@pinnaclehotels.ca. Should you have any questions, please contact Lynn Chang, Event Manager, 604-691-2722.

Cardholder Information

Name as it appears on the credit card: _____

Card type: Visa MC Amex Diners/CB Discover JCB

Credit Card Number: _____ Exp. date: _____

Billing Address: _____

City, Province/State and Postal Code/ Zip: _____

Phone number: _____ Fax or alternate number: _____

Event Information

Event Name & Date(s) _____

Company & Onsite Contact _____

Booth Number / Location _____

Duration of rental (days) _____

Requested Items – Please mark which items you require *(Contact the hotel to discuss other items not listed here)*

- | | |
|---|---|
| <input type="checkbox"/> Wired Internet - \$50 | <input type="checkbox"/> PC Windows Based Laptop - \$225 |
| <input type="checkbox"/> Multi-Access Power Distribution - \$35 | <input type="checkbox"/> LED Uplighting - \$50 each |
| <input type="checkbox"/> Screen Package (inc. power cord) - \$165 | <input type="checkbox"/> Easel - \$15 |
| <input type="checkbox"/> HD Projector/Screen Pkg - \$550 | <input type="checkbox"/> LCD Display Monitor (circle size): |
| <input type="checkbox"/> Mac Laptop - \$350 | |
| 22" - \$125 | 26" - \$180 |
| 42" - \$375 | 46" - \$450 |
| | 52" LED - \$550 |

Please note: all prices are per day, in Canadian Dollars & subject to service charge (20%) and applicable tax (7% PST / 5% GST). All pricing is subject to change without notice.

I certify that all information is complete and accurate. I hereby authorize Pinnacle Hotel Vancouver Harbourfront to collect payment for all charges associated with the rental of these requested items by processing a charge to the credit card listed above. Charges must not exceed _____ for the entire stay/event. I certify that I am the authorized signer of the credit card listed above.

Cardholder name: (Printed) _____

Cardholder signature: _____ Date: _____

Parking Rates

PINNACLE HOTEL HARBOURFRONT

Self Parking

\$28 + Tax

(Total \$35.57)

Valet Parking

\$33 + Tax

(Total \$41.93)

Transient Rate

\$6 valet service and hourly parkade rate

Self & Valet Parking

Include unlimited in/out privileges

Public Parkade Rates

Mon-Sun

Per 30 min \$3.75

Or portion thereof

Mon-Fri

Early Bird \$15

Enter between 6-9:30am Exit by 7pm

All Day Max \$21

(6am-6pm)

Evening Max \$6

(6pm-6am)

Sat & Sun

All Day Max \$7

(6am-6pm)

Evening Max \$7

(6pm-6am)