

WOODWORKS® Walls

Installation Instructions

1. GENERAL

1.1. Product Description

WoodWorks walls consist of 2' x 4', 2' x 8', 2' x 9' or 2' x 10' perforated and unperforated panels (Millworker quality) that are designed to be installed on an aluminum spline system or per the installing contractor's discretion with z-clips or another specified method.

1.2. Surface Finish

Face cut veneer with clear or tinted semi-gloss coating.

1.3. Storage and Handling

Ceiling components should be stored in a dry interior location and shall remain in cartons prior to installation to avoid damage. The cartons should be stored in a flat, horizontal position. The protectors between panels should not be removed until installation. Proper care must be taken when handling to avoid damage and soiling. Do not store in unconditioned spaces with humidity greater than 55% or lower than 25% RH and temperatures lower than 50°F or greater than 86°F. Panels must not be exposed to extreme temperatures, for example, close to a heating source or near a window where there is direct sunlight.

1.4. Site Conditions

WoodWorks wall panels should be permitted to reach room temperature and have a stabilized moisture content for minimum of 72 hours before installation. (Remove plastic wrap to allow panels to climatize). They should not, however, be installed in spaces where the temperature or humidity conditions vary greatly from the temperatures and conditions that will be normal in the occupied space.

1.4.1. HVAC Design & Operation

Proper design for both supply air and return air, aintenance of the HVAC filters, and building interior space are essential to minimize soiling. Before starting the HVAC system, make sure air supply is properly filtered and the building interior is free of construction dust.

1.4.2. Temperature & Humidity During Installation

WoodWorks wall panels are interior finish products that are designed for installation to be carried out in temperature conditions between 50°F (10°C) and 86°F (30°C), in spaces where the building is enclosed and HVAC systems are functioning and will be in continuous operation. Relative humidity shall not fall below 25% or exceed 55%. Additionally, the fluctuation in relative humidity shall not vary more than 30% over the life of the wall panels. All plastering, concrete, terrazzo or any other wet work shall be completely dry. All window and doors shall be in place. The heating, ventilation and air-conditioning system should be installed and operable where necessary to maintain proper temperature before, during and after installation of the WoodWorks panels.

1.5. Color

WoodWorks panels are made with a variety of real wood veneers. Natural variations in color and grain are characteristic of wood products. To maximize visual consistency, panels should be unpacked and examined collectively to determine the most desirable arrangement for installation. Where consistency is critical, Armstrong can offer custom solutions to meet your budget and aesthetic requirements. Consult HPVA for additional information on veneers and veneer grades.

2. INSTALLATION USING WALL SPLINES

2.1 Important Information

Aluminum wall splines must be used to install these panels. The decorative trim used can be aluminum or wood.

All panels must have kerfs on all four edges.

If the vertical joints of the wall panels are to line up with ceiling grid or some other feature that is on a 2' or 4' module, be aware that the panels are 23-3/4" wide and work with the splines that allow a 1/4" gap to maintain a 24" module.

We suggest that you limit the length of a section of wall to 24'. If the installation is to be longer than 24', you should create a "break" in the panels to allow for expansion and contraction due to air quality variations and humidity fluctuations in the area during seasonal changes and/or HVAC interruptions. Humidity must always be maintained between 25%RH and 55%RH.

Panels larger than 2' x 10' may not be installed using wall splines and will be custom ordered from Architectural Specialties.

2.2 Tools and Cutting Recommendations

You'll need the following tools: utility knife, laser or other level, straight edge, cordless drill with screw bits, cordless (or corded) circular saw, tape measure, spiral saw, pneumatic nail gun and compressor.

For cuts that will be seen, we recommend the following:

Circular saw – A circular saw makes a clean cut when the panel is cut from the back side. If the cut is made on the front side, there is too much splintering on the face due to the direction of the teeth on the blade. A considerable amount of dust is made with this cut.

Spiral Saw (Roto-Zip) – A spiral saw can be used to make cutouts for receptacles and switches or it can be used to make straight cuts to alter the length of the panels. This tool can make plunge cuts as well as cuts in from the edge. The cut is made from the face side. The resulting edges are clean and neat. This cut produces less airborne dust than the circular saw.

▲ CAUTION! WOOD DUST. Sawing, sanding and machining wood products can produce dust. Airborne wood dust can cause respiratory, eye and skin irritation. The International Agency for Research on Cancer (IARC) has classified wood dust as a nasal carcinogen in humans.

Precautionary measures: If power tools are used, they should be equipped with a dust collector. If high dust levels are encountered, use an appropriate NIOSH-designed dust mask. Avoid dust contact with eyes and skin.

First Aid Measure in case of irritation:

Flush eyes or skin with water for at least 15 minutes.

3. VERTICAL INSTALLATION USING WALL SPLINES

3.1 Install Furring

All vertical panel installations to walls with studs require horizontal wood furring. This is used to secure the wall splines to the wall. The furring must be secured to wall studs. If the wall is solid (block, concrete, etc.) furring is not required.

The first row of furring should be placed near the bottom of the wall so the ground strip can be attached to it. The second row of furring should be placed 3 inches above the first. Then secure rows of furring every 24 inches and within 3 inches of the top.

When panels are installed using splines mounted on furring, the 4 inch or 6 inch baseboard trims can be used.

3.2 Determine Width of Border Panels

If the installation of wall panels does not start and end against another wall, all of the panels should be full width.

If one or both ends of the installation are butted against other walls, it is unlikely that you will install all full width panels. The panels at each end should be equal and should be as large as possible.

The width of the panels, counting the trim strip, is 24". To calculate the width of the first and last panels on a wall, measure the length of the wall. Divide this measurement by 2'. Take the remainder, add 2', and divide in half. This is the width of the first panel.

EXAMPLE: If the room measures 17' 4", divide this by 2' and get 13 with a remainder of 1' 4". Add 2' to this and get 3' 4". Divide this in half and get 20". This is the width of the first panel. You may need to calculate the width of the border panels first if the floor is not very level (see next step).

3.3 Establish a Level Line

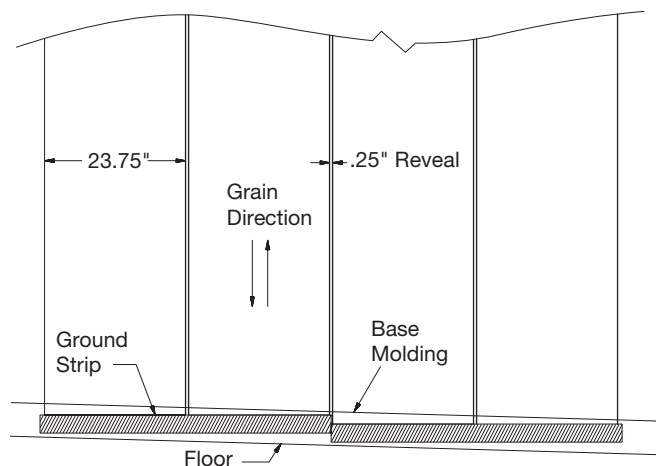

Establish a level line along the wall near the floor as a base for the wall panels. This line should be 1/2" lower than the finished height (either 4" or 6") of the base molding you are using.

NOTE: Make sure the level line is no higher from the floor than the height of the base molding. If the floor is extremely out of level, you may have to strike more than one level line to accommodate the floor slope. This would result in a "stepped" level line. If the level line is "stepped", the step must occur between panels.

Install 3/4" thick lumber (by others), aligning the top of the lumber with the level line. The width of this lumber needs to be 2" - 4", depending on slope conditions and base molding height.

Secure the lumber to wall studs with appropriate fasteners. You will use this lumber as a "ground strip". The bottom edge of the wall panels will rest on this lumber. It is important that they are installed level, so the panels are plumb when they are sitting on them.

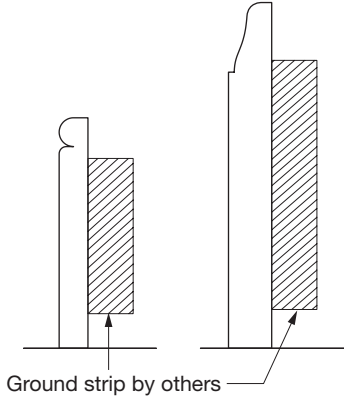

Trim the ends of the base molding as necessary and fasten the base molding to the "ground strip" already installed on the wall.

The bottom edge of the base molding will rest against the floor surface and cover the "ground strip". Use an appropriate fastener. A pneumatic nail gun works well for this.

If the base molding does not reach from wall to wall, miter a "return" on the base molding where it ends.

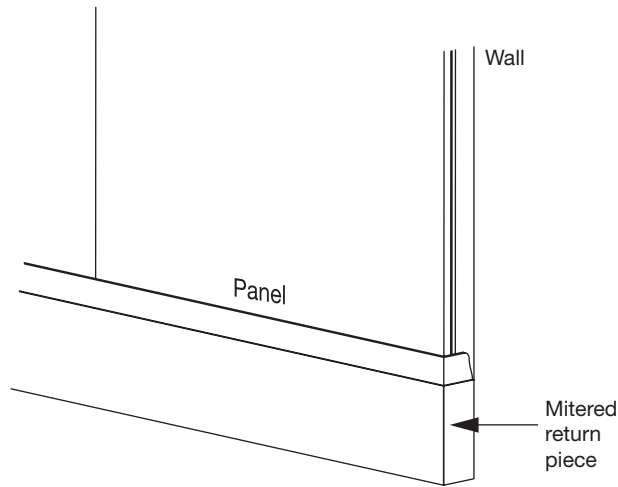

3.4 Panel Installation

Finish molding can be used at each side and at the top of all installations to cover raw edges of the panels. Install finish molding vertically at one end of the installation. The bottom end of the finish molding will rest on the top of the base molding with a straight cut. Miter the top end of the finish molding so that the rabbet in the back of the molding is 1/8"

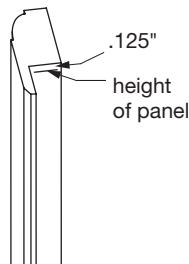

higher than the panel if the panel does not go to the existing ceiling.

If the panels are to reach the existing ceiling, cut the long point of the miter to the existing ceiling height and cut the panel 1-1/8" short of the ceiling height.

If the installation is not wall to wall, install the finish molding plumb. If the installation is wall to wall, install the molding against the abutting wall.

Measure out from the abutting wall, or the starting point, the calculated border dimension. Strike a plumb line on the wall where the edge of the first panel will fall. Measure from the rabbet in the finish molding to the plumb line several places and mark the panel where you will cut it. Cut to width using these marks as a guide. Measure the desired height of the panel and cut the panel to this measurement. Place the bottom edge of the panel on the ground strip and slide the panel sideways into the rabbet in the finish molding, leaving a 1/4" gap between the panel edge and the finish molding rabbet as shown.

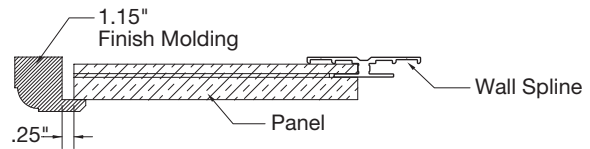
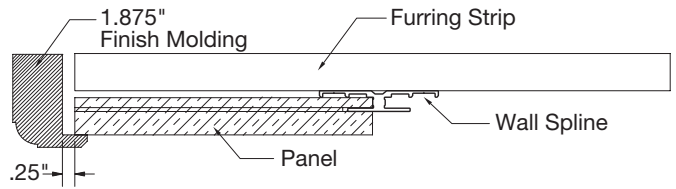

Cut the 1/2" decorative trim so it rests on the ground strip and extends to the top of the panel. Then fit the decorative trim into a wall spline and slide the spline into the kerfed edge of the first panel.

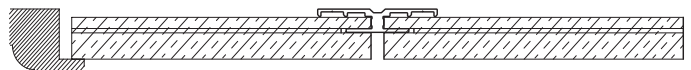
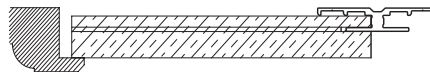
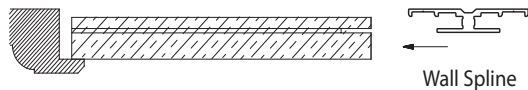

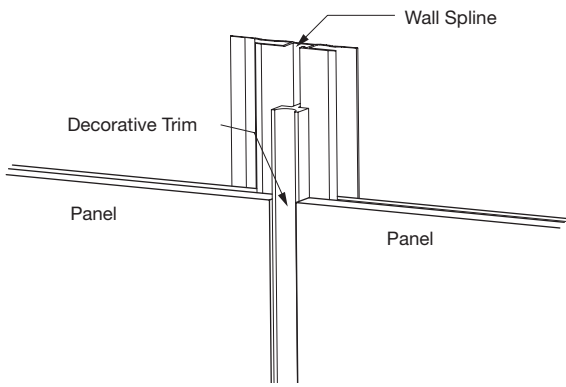

Cut the next panel to height, fit a decorative trim into the spline, slide the spline into the kerf in the panel, and fasten the spline to the wall as before.

Fasten the spline to the wall using appropriate fasteners for the composition of the wall. Be aware that the screw heads must be as flat as possible, or countersunk, so they do not interfere with the next panel fitting into the spline.

Continue in this manner until you reach the other end of the wall you are installing. If the installation is wall to wall, cut the last panel short of the abutting wall allowing space (about 1 1/4") for the finish molding to be installed at the end after the panel is installed. If you are not butting against another wall at the end, install the last full width panel and then install the vertical finish molding 1/8" from the edge of the last panel.

Cut and fit finish molding across the top of the panels to meet the vertical finish moldings at the sides of the installation.

3.5 Limits On Length of Run

For runs of panels longer than 24 feet, you we suggest that you "break" the installation or divide the run into smaller segments so all segments are no longer than 24 feet.

3.6 Cutouts for Switches and Receptacles

Carefully locate the desired cutouts on the face of the panel to allow access to remount the switch or receptacle. A qualified electrician may have to install a box extension for the switch or receptacle before the panel is installed. Mount the panel on the wall and secure with a spline. Have the electrician remount the switch or receptacle.

3.7 Outside Corners

Outside corners are handled by installing a corner spline on the corner of the wall. Be sure to leave a gap of 1/8" – 1/4" between the panel edge and the stop on the corner spline. You then drive a decorative wood corner onto the spline after the panels are in place.

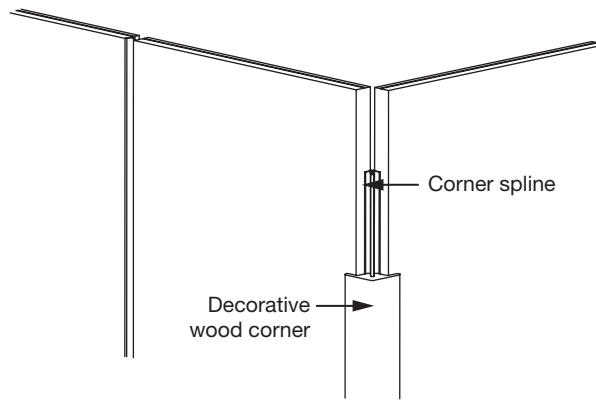
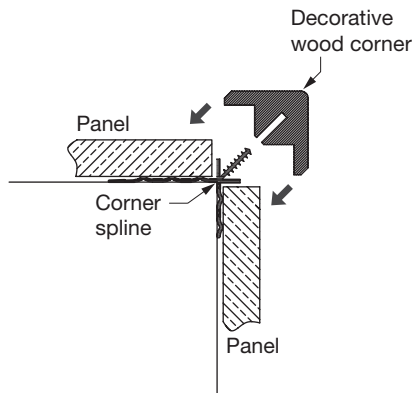

3.8 Inside corners

When panels meet at an inside corner, you should scribe fit one of the panels to butt against the other panel. Use a construction adhesive (follow the adhesive manufacturer's recommendations for application) to secure the panels to the wall where you have no splines or other means of securing them. Item #5867 corner molding can be used to trim this inside corner.

3.9 Stacking

Vertically installed panels can be stacked to a maximum height of twenty feet. Horizontal wall splines must be used between the top of the first row of panels and the bottom of the second row of panels. These splines must be firmly attached to wall studs or a solid wall to provide adequate support for the panels above. Use fasteners (by others) that are appropriate for the wall construction.

4. HORIZONTAL INSTALLATION USING WALL SPLINES

Follow the instructions for mounting the "ground strip" as shown in section 3.3 above.

4.1 Horizontal Panel Installation

If the vertical joints between panels are to line up with any features on the ceiling that recur on a 2' (or multiple of 2') module, adjust the length of the first horizontal panel so the first vertical joint aligns with this feature. Install the first vertical wall spline so it will line up with the ceiling feature. The length of this spline is the same as the intended height of the last panel.

Fasten the spline to the wall using appropriate fasteners for the composition of the wall. Be aware that the screw heads must be as flat as possible, or countersunk, so they do not interfere with the next panel fitting into the spline.

Finish molding can be used at each side and at the top of all installations to cover raw edges of the panels. Install finish molding vertically at one end of the installation. The bottom end of the finish molding will rest on the top of the base molding with a straight cut. Miter the top end of the finish molding so that the rabbet in the back of the molding is 1/8" higher than the top course of panels if the panels will not reach the existing ceiling. The first panel should be placed in the finish molding so there is a 1/4" gap between the inside of the finish molding and the end of the panel.

If the top course of panels are to reach the existing ceiling, cut the long point of the miter to the existing ceiling height and cut the last course of panels 1-1/8" short of the ceiling height.

If the installation is not wall to wall, install the finish molding plumb. If the installation is wall to wall, install the molding against one abutting wall.

Place the first panel on the ground strip at one side of the installation and place a wall spline into the top edge of the panel. The spline should be cut one inch shorter than the panel; cut a 3/4" x 1/4" section out of the ends of the spline as shown below. The end of the horizontal wall spline will butt up against the side of the vertical wall spline. If you are installing the first or last column of panels only cut the 3/4" x 1/4" section out of one end. Secure the horizontal spline to wall studs or a solid wall with the appropriate fasteners (by others). **Use a black marker to blacken the raw aluminum ends of the cut wall spline.**

Cut (if necessary) and install the second panel on top of the first. Insert and secure the horizontal spline on top of the panel as you did with the first spline.

Continue installing panels and splines to the top of the installation. Start the next column of panels in the same way as you started the first.

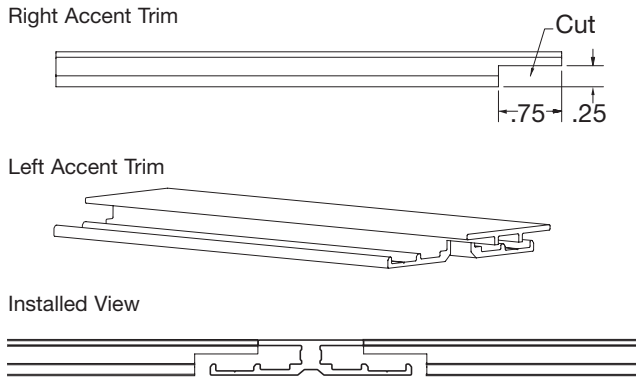

5 INSTALLING CHAIR RAIL ACCESSORIES

5.1 Chair Rail with Insert

Mark a level line on the wall at the desired height of the chair rail.

Wall panels fit above and/or below the chair rail and rest in the channel on the top and/or bottom side of the Mounting Rail (see illustration).

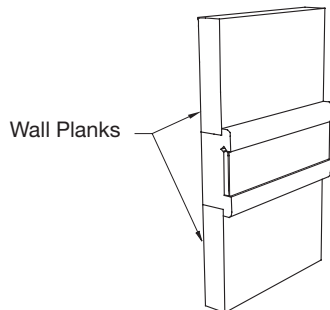

Predrill and countersink holes for flat head screws in the insert channel of the Mounting Rail.

Align rail with the level line and fasten the rail to each wall stud. Use flat head screws appropriate for the wall construction. Install your choice of Rail Insert in the channel using carpenter's glue and brads.

NOTE: The Rail Insert with the aluminum face is secured to the rail with double faced tape (by others). The aluminum Rail Insert has a protective film on the face that should be removed before securing to the rail.

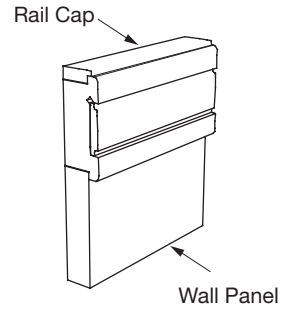

If wall panels are to be installed below the chair rail and not above the chair rail, you install a Rail Cap above the chair rail using carpenter's glue and brads. One Rail Cap is used (see illustration).

5.2 Chair Rail with Easel Ledge

Mark a level line on the wall at the desired height of the chair rail.

Predrill and countersink holes for flat head screws in the insert channel of the Mounting Rail.

Align rail with the level line and fasten the rail to each wall stud. Use flat head screws appropriate for the wall construction.

If wall panels are to be installed below the chair rail and not above the chair rail, you install a Rail Cap above the chair rail using carpenter's glue and brads. One Rail Cap is used (see illustration).

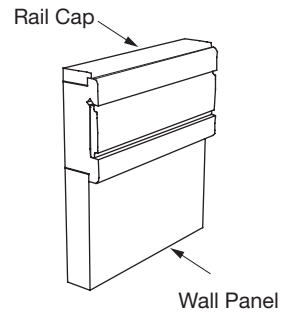

Insert the Easel Ledge into the accent channel in the Mounting Rail and secure it in place with screws through the predrilled and countersunk holes as shown (see illustration).

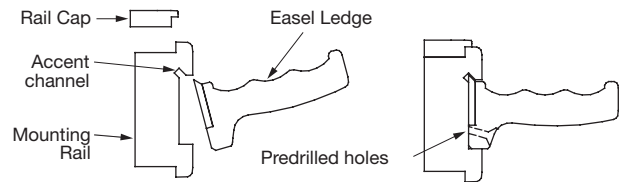

NOTE: The Easel Ledge installation into the Mounting Rail is the same whether or not partial wall installation with Rail Caps is used.

6. INSTALLATION USING Z-CLIPS

All panels intended for Z-clip installations should be ordered with no kerfs in any of the edges.

Panels installed with Z-clips shall have a gap of at least 1/4" between panels.

Panels can be installed horizontal or vertical.

Panels over 2' x 4' up to 2' x 8' shall be fastened to the wall with 6 Z-clips, two near each end and two on each side of the center.

Panels larger than 2' x 8' shall be fastened to the wall with 8 Z-clips, two near each end and two on each side at the third points.

Each Z-clip should be secured to the back of the panels with two #8 x 5/8" modified truss head sharp point screws.

Z-clips shall be secured to the wall with appropriate fasteners for the construction of the wall.

There is no limit to the length of run. Each panel is isolated from every other panel.

Panels 2' x 4' and smaller require 4 Z-clips.

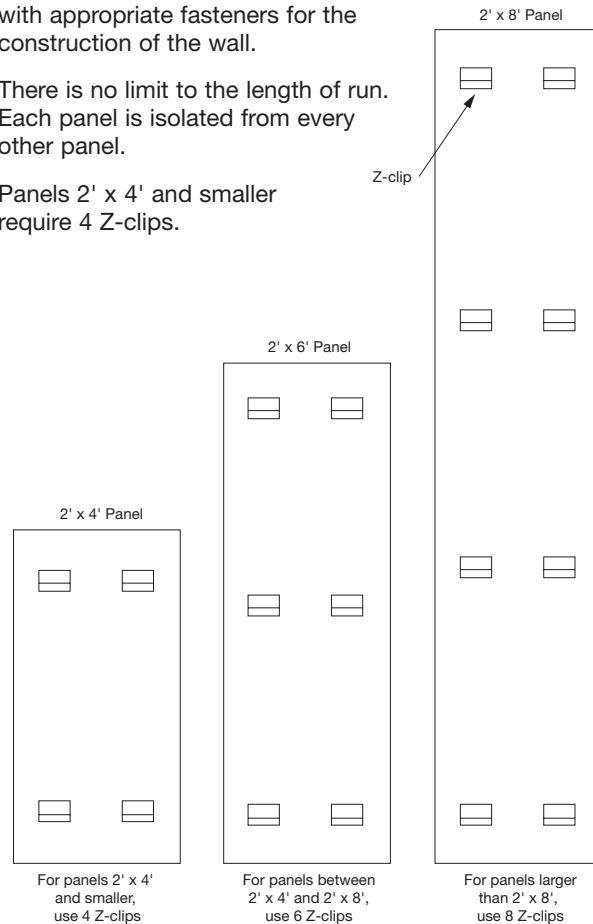

MORE INFORMATION

For more information, or for an Armstrong representative, call 1 877 276 7876

For complete technical information, detail drawings, CAD design assistance, installation information and many other technical services, call TechLine™ services at 1 877 276 7876 or FAX 1 800 572 TECH.

For the latest product selection and specification data, visit armstrongceilings.com/walls

U.S. Patents 5,417,025; 5,253,463; 5,355,646

All trademarks used herein are the property of AWI Licensing Company and/or its affiliates.
© 2012 AWI Licensing Company Printed in the United States of America

BPLA-297712-1012