

1. Install Guardrail Post A extending ~32 inches above the ground at a spacing of 6'3" from the end of the length of need and inline with the length of need.
2. Install Guardrail Post B extending ~32 inches above the ground at a spacing of 6'3" from Guardrail Post A and inline with Guardrail Post A and the length of need.
3. Install Guardrail Post C extending ~32 inches above the ground at a spacing of 6'3" from Guardrail Post B and inline with Guardrail Post B and Guardrail Post A.
4. Install Guardrail Post D extending ~32 inches above the ground at a spacing of 6'3" from Guardrail Post C and inline with Guardrail Post C and Guardrail Post B.
5. Install Guardrail Post E extending ~32 inches above the ground at a spacing of 6'3" from Guardrail Post D and inline with Guardrail Post D and Guardrail Post C.
6. Install Guardrail Post F extending ~32 inches above the ground at a spacing of 6'3" from Guardrail Post E and inline with Guardrail Post E and Guardrail Post D.
7. Install Strut Post G extending ~32 inches above the ground at a spacing of 6'3" from Guardrail Post F and offset 8" toward road from the line of Guardrail Posts F and E.
8. Install Soil Tube H extending ~2.5 inches above the ground at a spacing of 6'3" from Strut Post G and offset 6" toward road from the line of Guardrail Posts F and E.

- A** - 4"X6"X6' Guardrail Post  
{w/four ½"holes in flanges near ground}
- B** - 4"X6"X6' Guardrail Post  
{w/four ½"holes in flanges near ground}
- C** - 4"X6"X6' Guardrail Post  
{w/four ½"holes in flanges near ground}
- D** - 4"X6"X6' Guardrail Post  
{w/four ½"holes in flanges near ground}
- E** - 4"X6"X6' Guardrail Post  
{w/four ½"holes in flanges near ground}
- F** - 4"X6"X6' Guardrail Post  
{w/four ½"holes in flanges near ground}
- G** - 4"X6"X6' Strut Post  
{w/four ½"holes in flanges near ground}
- H** - 6"X8"X6' Soil Tube

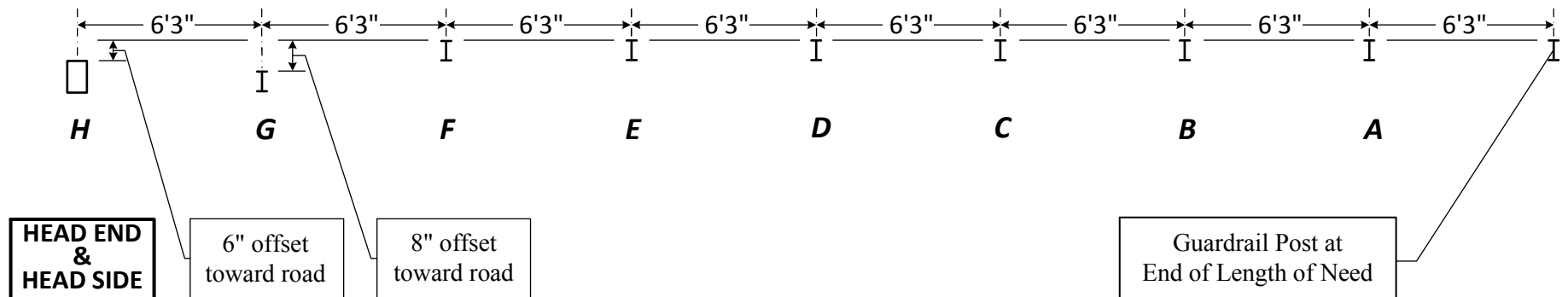

## [LEFT SIDE] I. INSTALLATION OF POSTS AND TUBE

**SPIG Industry, LLC**

PO Box 2617

Abingdon, VA 24212

SHEET NO.

DATE:

L 1 of 20

4/2/20

1. Insert 50" Wood Breakaway Post into Soil Tube **G** until hole in Soil Tube matches hole in Wood Breakaway post.

**G** - 4"X6"X6' Strut Post  
 {w/four 1/2" holes in flanges near ground}  
**H** - 6"X8"X6' Soil Tube

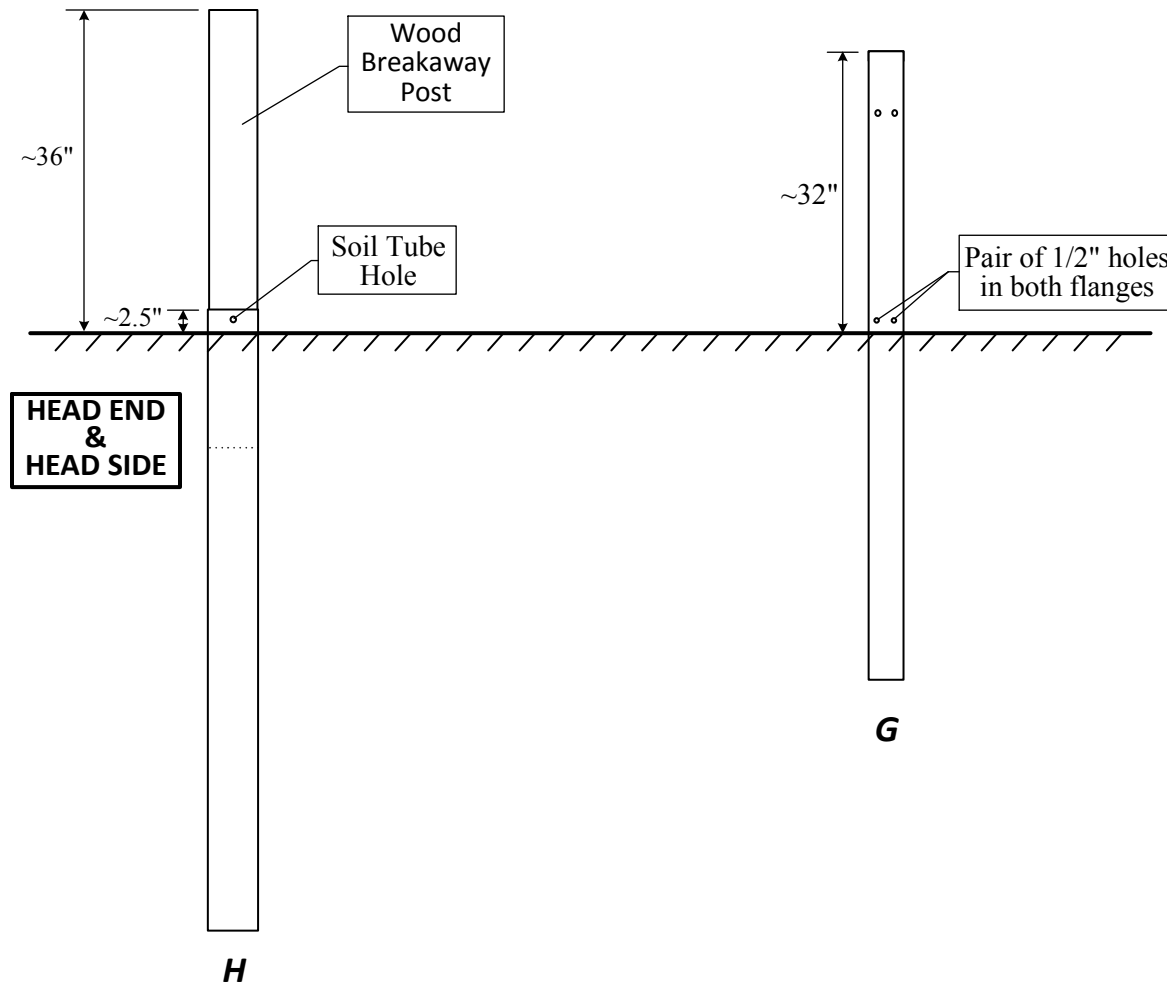

[LEFT SIDE] II. INSTALLATION OF 50" WOOD BREAKAWAY POST

**SPIG Industry, LLC**

PO Box 2617  
 Abingdon, VA 24212

SHEET NO.

DATE:

L 2 of 20

4/2/20

1. (Left Road Side) Position Strike Block on Wood Breakaway Post such that lip of Strike Block is on side of Wood Breakaway Post opposite the Head Side of Wood Breakaway Post and then position Strike Plate on Strike Block such that lip of Strike Plate is on head side of Strike Block.
2. (Left Road Side) Insert 14" (or 12") long 5/8" guardrail bolt through the lower hole of the Strike Plate, through the Strike Block, and then the Wood Breakaway Post. Then, put 5/8" washer and 5/8" nut on the 14" (or 12") long 5/8" guardrail bolt.

H - 6"X8"X6' Soil Tube

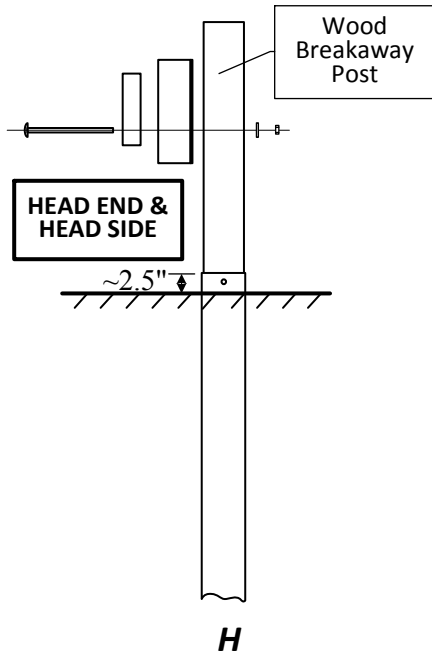

**SIDE VIEW**

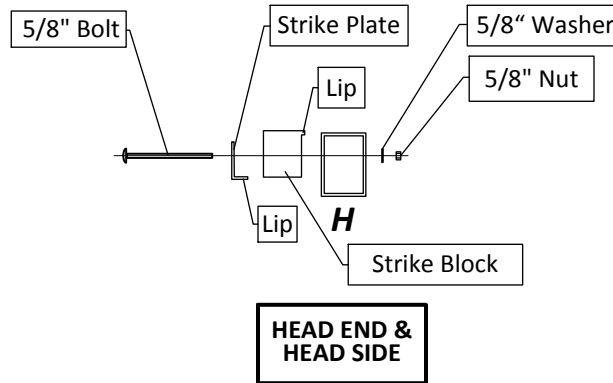

**TOP VIEW**

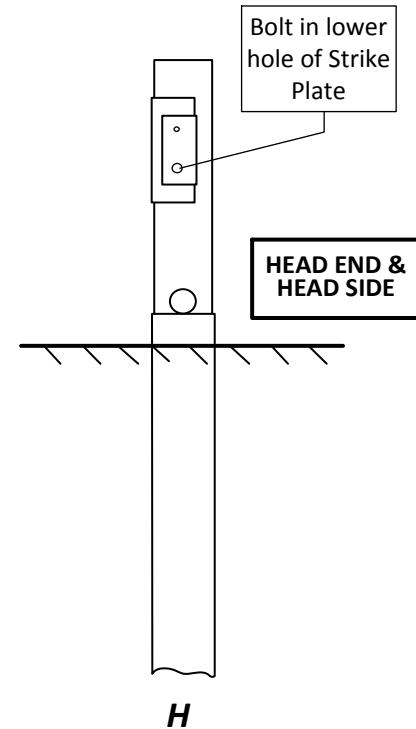

**FRONT VIEW**

**[LEFT SIDE] IIIa. INSTALLATION OF STRIKE PLATE AND STRIKE BLOCK**

**SPIG Industry, LLC**  
 PO Box 2617  
 Abingdon, VA 24212

SHEET NO.

DATE:

L 3 of 20

4/2/20

3. Tighten 5/8" nut on 14" (or 12") long 5/8" guardrail bolt inserted through the lower hole of the Strike Plate, through the Strike Block, and then the Wood Breakaway Post.

**G** - 4"X6"X6' Strut Post  
 {w/four 1/2" holes in flanges near ground}  
**H** - 6"X8"X6' Soil Tube

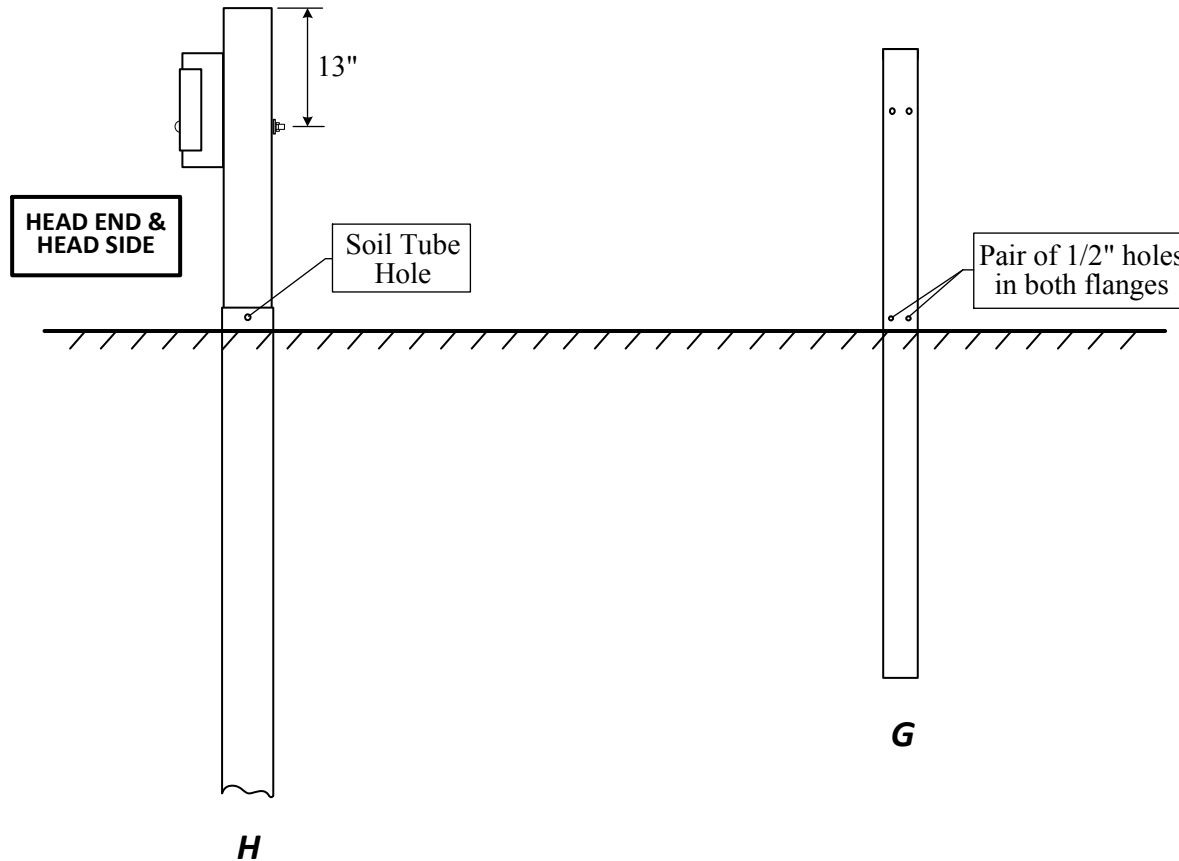

**[LEFT SIDE] IIIb. INSTALLATION OF STRIKE PLATE AND STRIKE BLOCK**

**SPIG Industry, LLC**  
 PO Box 2617  
 Abingdon, VA 24212

SHEET NO.

DATE:

L 4 of 20

4/2/20

1. Position Strut between Strut Post G and Soil Tube H such that one flange of the Strut is on top and the other flange of the Strut is against Strut Post G and Soil Tube H.
2. Insert washered 2" long 1/2" bolts under the one flange and through both the Strut and Strut Post G. Then, put washers, lock washers and nuts on the 2" long 1/2" bolts to attach the Strut to the Strut Post G.
3. Insert washered 10" long 5/8" bolt under the one flange and through the Strut, Soil Tube H and Wood Breakaway Post. Then, put washers, lock washers and nuts on the 10" long 5/8" bolt to attach the Strut to the Soil Tube H and the Wood Breakaway Post.

**G** - 4"X6"X6' Strut Post  
 {w/four 1/2" holes in flanges near ground}  
**H** - 6"X8"X6' Soil Tube

Note: Alternatively, the washer 2" long 1/2" bolts and/or the 10" long 5/8" bolt can be inserted through in the opposite direction.

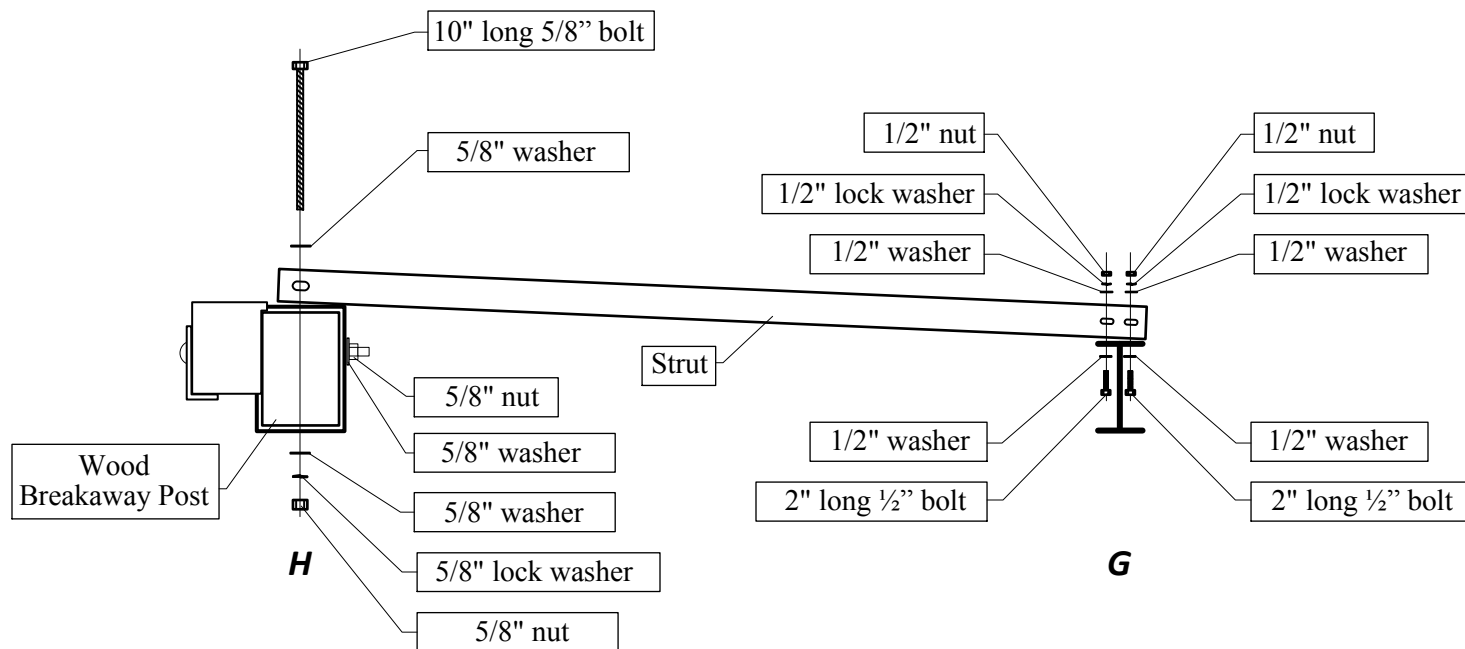

**[LEFT SIDE] IV. INSTALLATION OF STRUT**

**SPIG Industry, LLC**  
 PO Box 2617  
 Abingdon, VA 24212

SHEET NO.

DATE:

L 5 of 20

5/4/20

1. Attach 9' 4½" Panel to the Guardrail Panel coming from the end of the length of need and to Guardrail Post A through 8" Block Outs using 10" guardrail bolts.
2. Attach 12' 6" Panel to the 9' 4½" Panel using 1" splice bolts.
3. Attach 12' 6" Panel to Guardrail Posts B through D through 8" Block Outs using 10" guardrail bolts.
4. Attach another 12' 6" Panel to the 12' 6" Panel using 1" splice bolts.
5. Attach the other 12' 6" Panel to Guardrail Posts D through F through 8" Block Outs using 10" guardrail bolts.

Notes: 12' 6" Panels can be standard or MGS guardrail.  
Splice bolt holes of the 12' 6" Panels are at Posts.

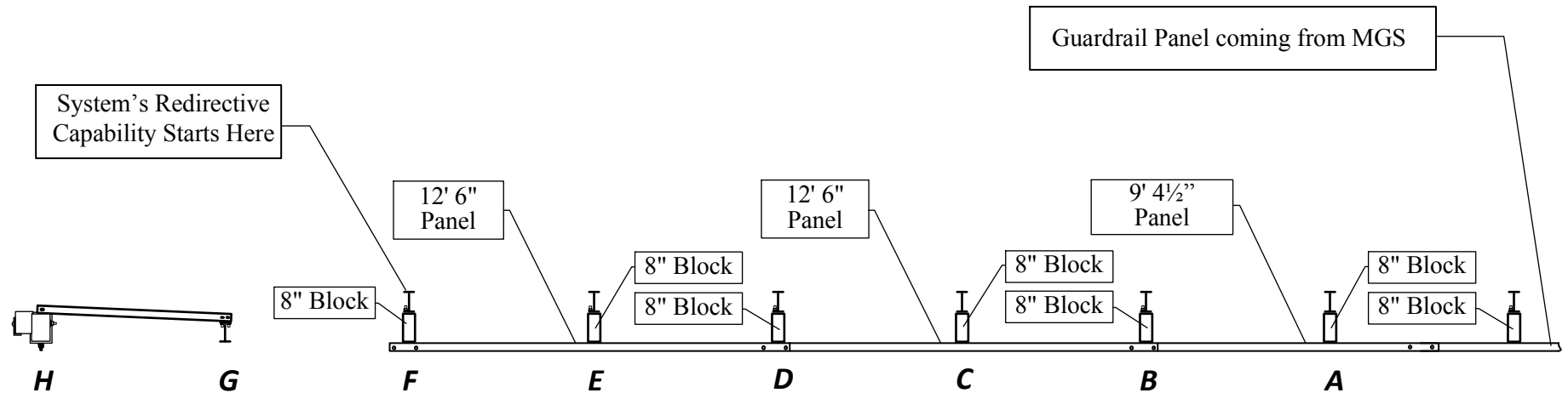

**[LEFT SIDE] V. INSTALLATION OF PANELS (12' 6" & 9' 4½")**

**SPIG Industry, LLC**

PO Box 2617  
Abingdon, VA 24212

SHEET NO.

DATE:

L 6 of 20

4/2/20

7. Attach Specialty Panel to Guardrail Post F through an 8" Block Out using 10" guardrail bolt and to Guardrail Post G .
8. Attach Specialty Panel to the Third 12" 6" Panel using 1" splice bolts.
9. DO NOT ATTACH Specialty Panel to the Wood Breakaway Post in Soil Tube H. The end of the Specialty Panel just lays across the Wood Breakaway Post in Soil Tube H.

- F** - 4"X6"X6' Guardrail Post  
 {w/four ½" holes in flanges near ground}
- G** - 4"X6"X6' Strut Post  
 {w/four ½" holes in flanges near ground}
- H** - 6"X8"X6' Soil Tube

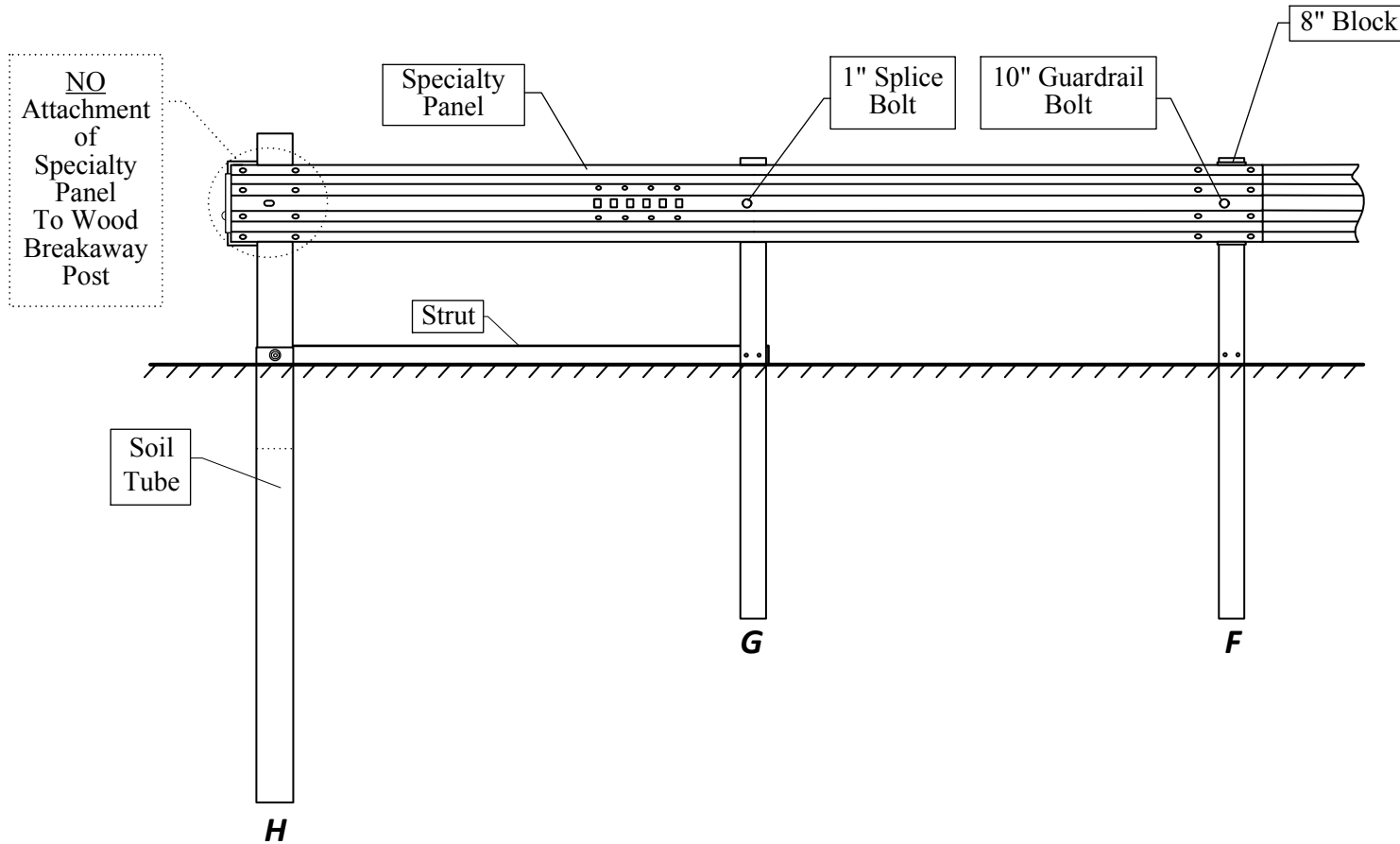

[LEFT SIDE] VI. INSTALLATION OF SPECIALTY PANEL

**SPIG Industry, LLC**

PO Box 2617  
 Abingdon, VA 24212

SHEET NO.

DATE:

L 7 of 20

4/2/20

1. Place Reinforcement Panel behind Specialty Panel and align all of the square holes of the Reinforcement Panel correspondingly to all of the square holes in the Specialty Panel such that the Reinforcement Panel is positioned on the back side of the Specialty Panel with the round bolt holes of the Specialty Panel corresponding to the oblong bolt holes of the Reinforcement Panel.
2. Insert washered 1.25" long ½" bolts from the front side of the Specialty Panel through the round holes of the Specialty Panel and the oblong holes of the Reinforcement Panel. Then, put washers, lock washers and nuts on ends of the 1" long ½" bolts outside of the Reinforcement Panel, which is on the back side of the Specialty Panel.

**G** - 4"X6"X6' Strut Post  
 {w/four ½"holes in flanges}  
**H** - 6"X8"X6' Soil Tube

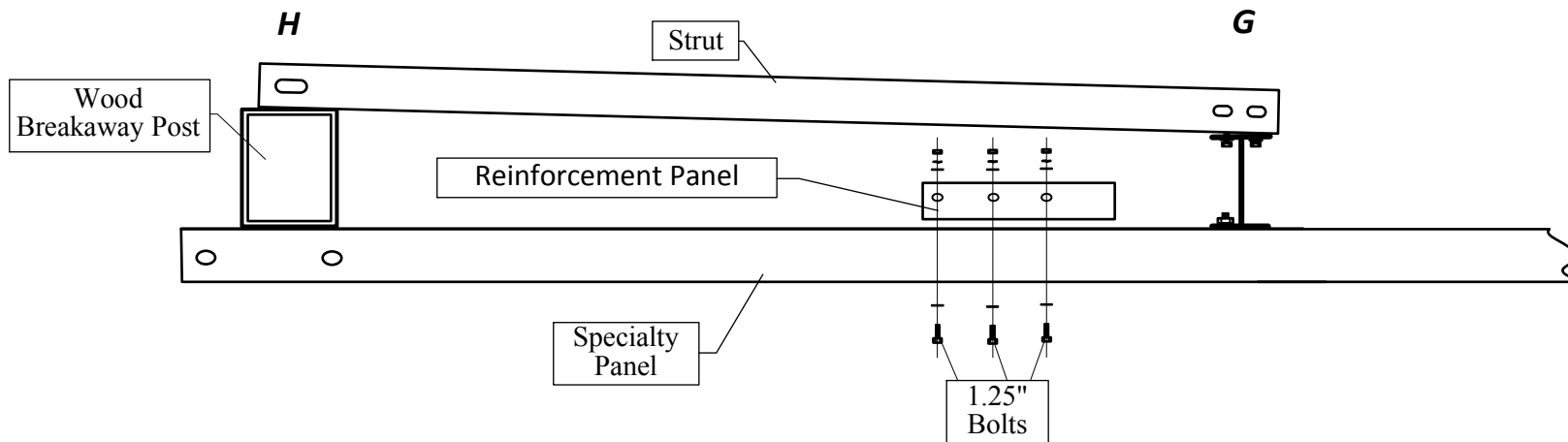

**[LEFT SIDE] VII. INSTALLATION OF REINFORCEMENT PANEL**

**SPIG Industry, LLC**  
 PO Box 2617  
 Abingdon, VA 24212

SHEET NO.

DATE:

L 8 of 20

4/2/20



1. Insert rectangular-shaped pegs of Guardrail grabber into corresponding rectangular holes in both the Reinforcement Panel and the Specialty Panel with the teeth of the Guardrail Grabber pointing toward the front end of the specialty panel.

**G** - 4"X6"X6' Strut Post  
 {w/four ½" holes in flanges}  
**H** - 6"X8"X6' Soil Tube

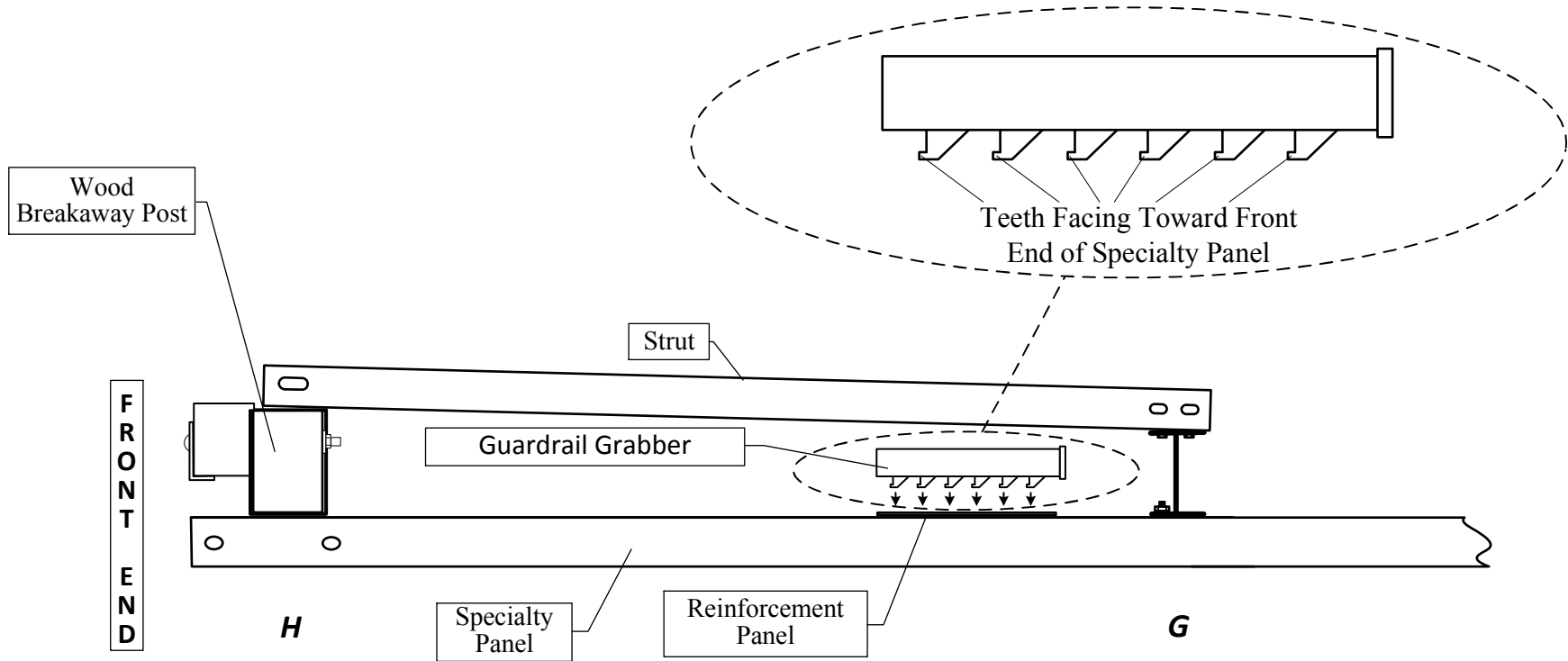

**[LEFT SIDE] VIIIa. INSTALLATION OF GUARDRAIL GRABBER**

**SPIG Industry, LLC**  
 PO Box 2617  
 Abingdon, VA 24212

SHEET NO.

DATE:

L 9 of 20

4/2/20

2. After insertion of the Guardrail Grabber into the Reinforcement Plate, slide Guardrail Grabber forward toward the front end of the Specialty Panel such that the teeth of the Guardrail Grabber lock onto the front side (or road side) of the specialty panel. A hammer may be used to assist in sliding the Guardrail Grabber forward toward the front end of the Specialty Panel.

**F** - 4"X6"X6' Guardrail Post  
**G** - 4"X6"X6' Strut Post  
 {w/four ½"holes in flanges}  
**H** - 6"X8"X6' Soil Tube

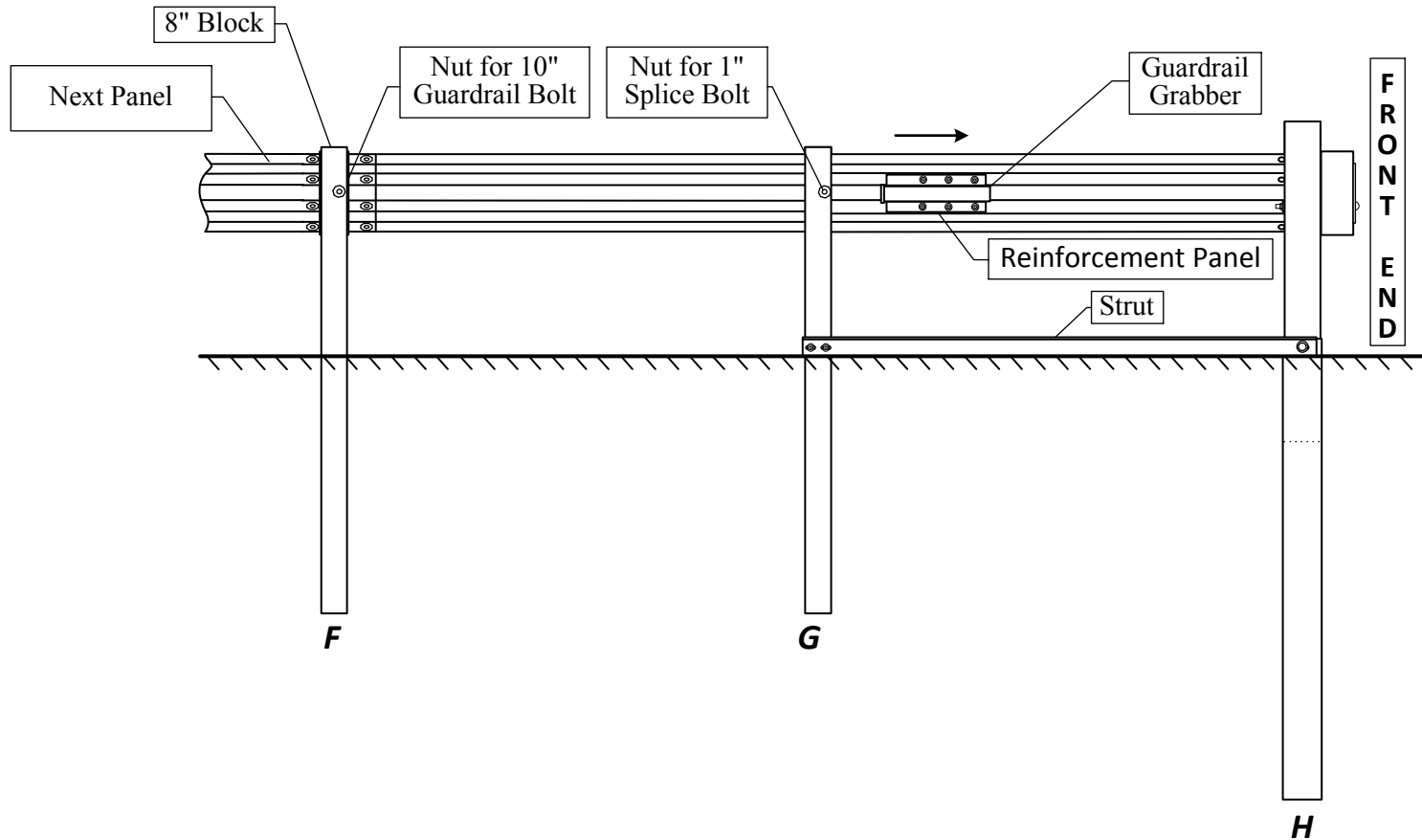

**[LEFT SIDE] VIIIb. INSTALLATION OF GUARDRAIL GRABBER**

**SPIG Industry, LLC**

PO Box 2617  
 Abingdon, VA 24212

SHEET NO.

DATE:

L 10 of 20

4/2/20

4. After sliding the Guardrail Grabber forward toward the front end of the Specialty Panel Specialty Panel, tighten the 1" bolts attaching the Reinforcement Panel to the Specialty such that the locknuts are completely crushed and then at least another half turn.

**F** - 4"X6"X6' Guardrail Post  
**G** - 4"X6"X6' Strut Post  
 {w/four ½" holes in flanges}  
**H** - 6"X8"X6' Soil Tube

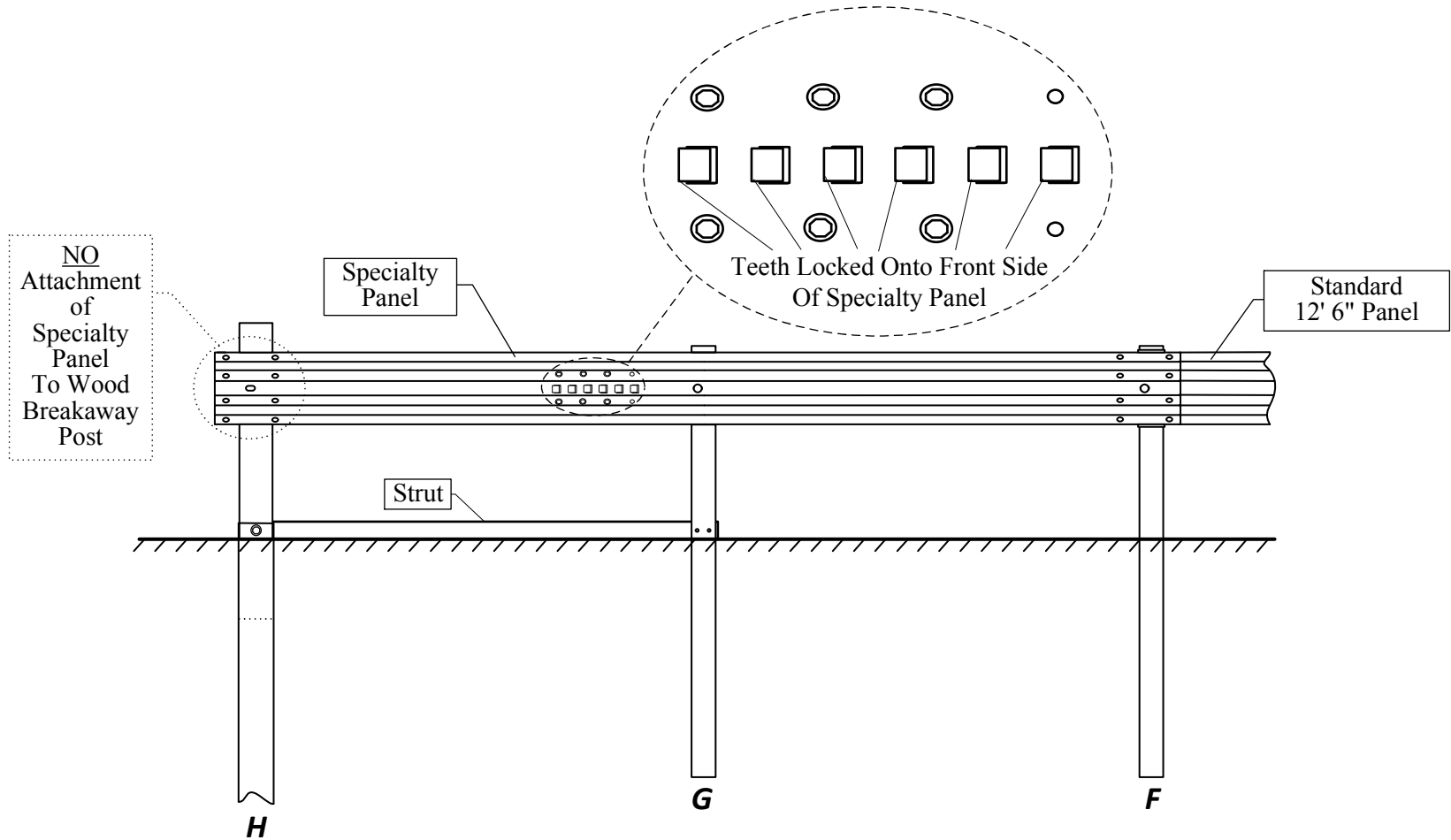

**[LEFT SIDE] VIIIc. INSTALLATION OF GUARDRAIL GRABBER**

**SPIG Industry, LLC**  
 PO Box 2617  
 Abingdon, VA 24212

SHEET NO.

DATE:

L 11 of 20

4/2/20

1. Insert Zip Tie through Plastic Spacer and zip tie plastic spacer into the top feed channel downstream of top mounting tab.

**F** - 4"X6"X6' Guardrail Post  
**G** - 4"X6"X6' Strut Post  
 {w/four 1/2" holes in flanges}  
**H** - 6"X8"X6' Soil Tube

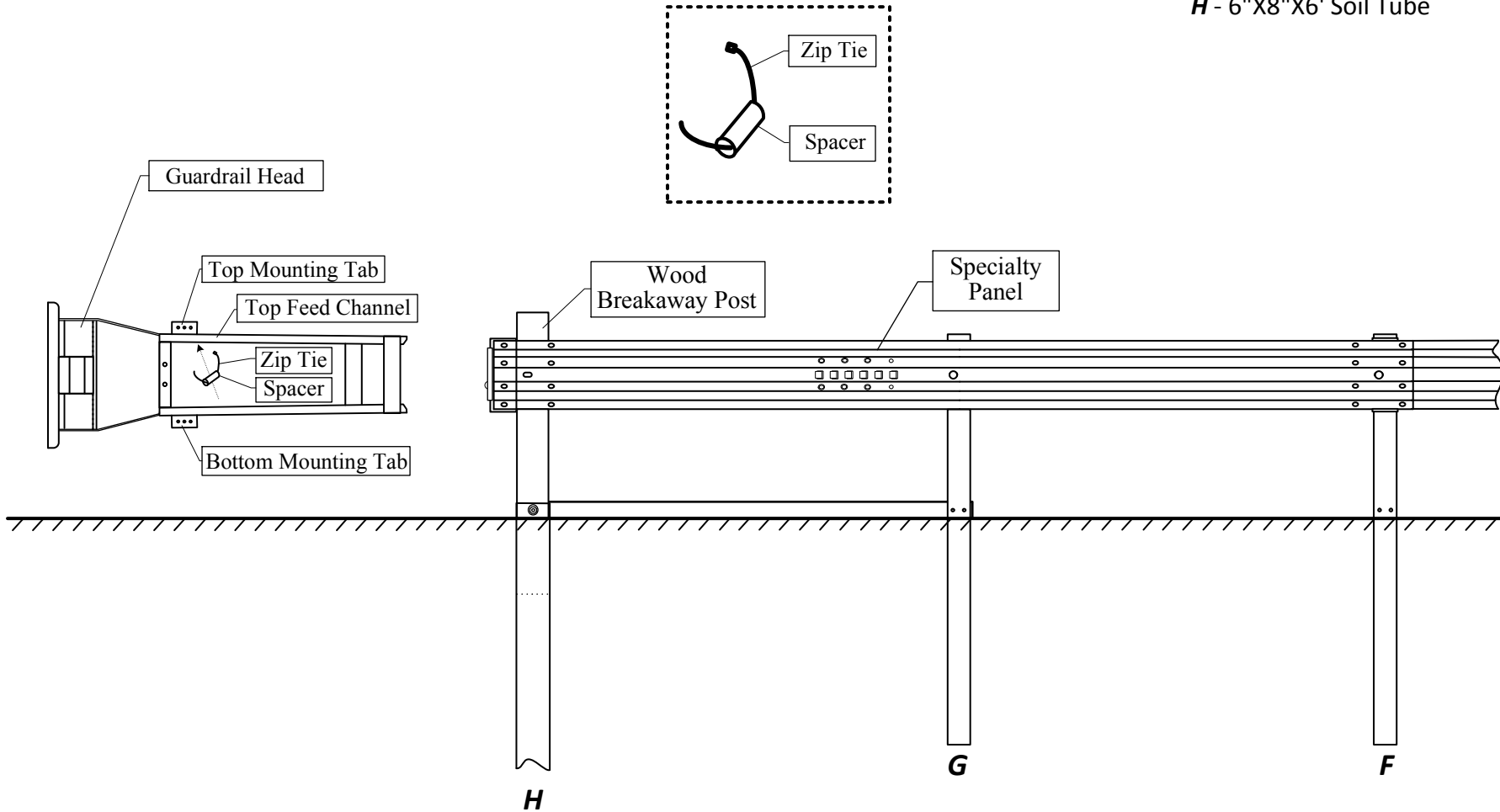

[LEFT SIDE] IXa. INSTALLATION OF GUARDRAIL HEAD

**SPIG Industry, LLC**  
 PO Box 2617  
 Abingdon, VA 24212

SHEET NO.

DATE:

L 12 of 20

4/2/20

2. Tighten Zip Tie such that plastic spacer is within the top feed channel downstream of top mounting tab.
3. Slide Guardrail Head onto Specialty Panel.

**F** - 4"X6"X6' Guardrail Post  
**G** - 4"X6"X6' Strut Post  
 {w/four ½" holes in flanges}  
**H** - 6"X8"X6' Soil Tube

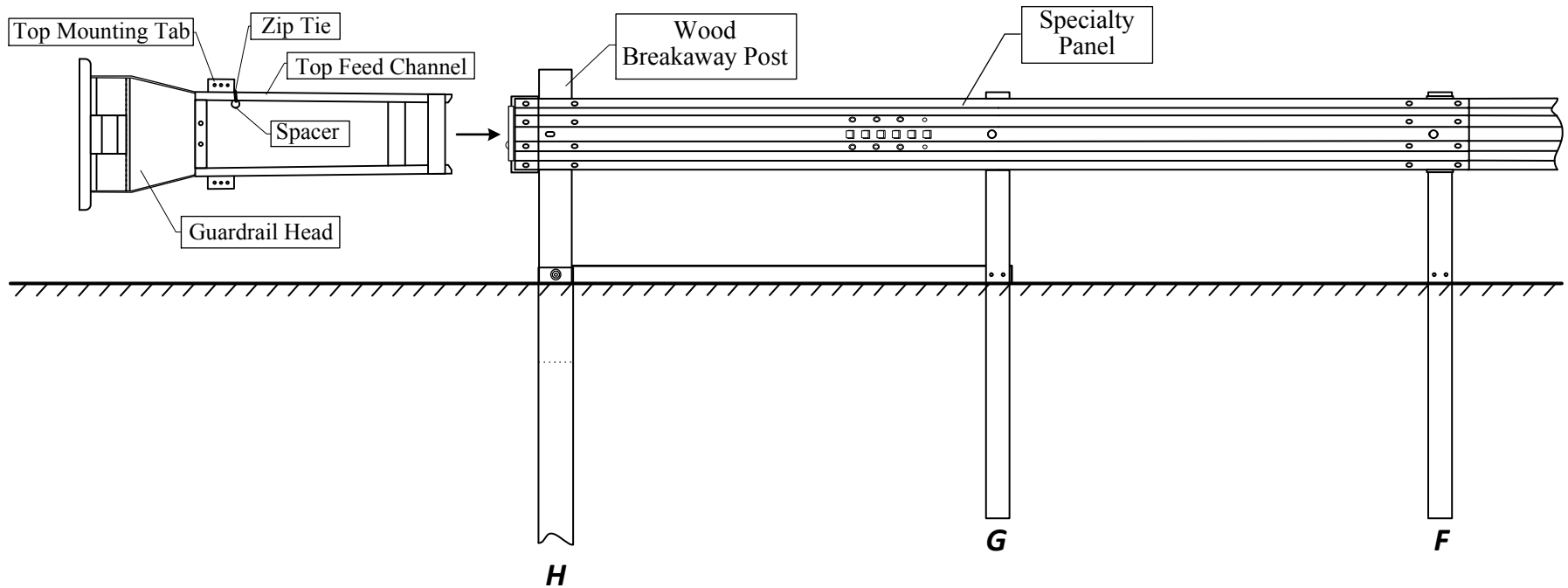

**[LEFT SIDE] IXb. INSTALLATION OF GUARDRAIL HEAD**

**SPIG Industry, LLC**  
 PO Box 2617  
 Abingdon, VA 24212

SHEET NO.

DATE:

L 13 of 20

4/2/20

4. Slide the Guardrail Head onto the Specialty Rail until the Guardrail Head is stopped by the Specialty Panel. Note that the Rail Mounting Hole of the Specialty Panel should be centrally positioned between the Viewing Holes of the Guardrail Head and that the Top and Bottom Mounting Tabs are directly over each other.

**F** - 4"X6"X6' Guardrail Post  
**G** - 4"X6"X6' Strut Post  
 {w/four ½"holes in flanges}  
**H** - 6"X8"X6' Soil Tube

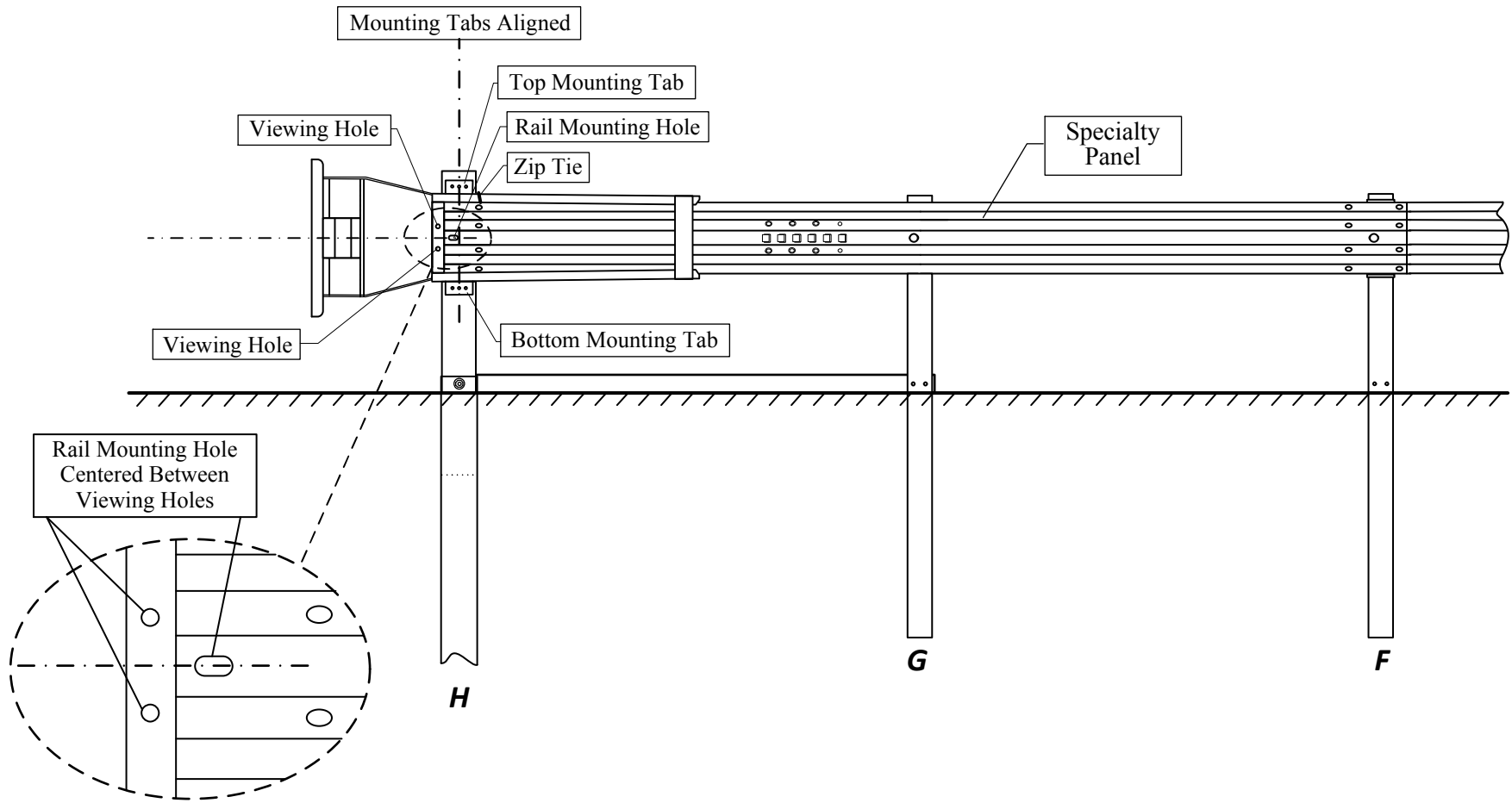

**[LEFT SIDE] IXc. INSTALLATION OF GUARDRAIL HEAD**

**SPIG Industry, LLC**  
 PO Box 2617  
 Abingdon, VA 24212

SHEET NO.	DATE:
L 14 of 20	4/2/20

5. Attach upper and lower Mounting Tabs of Guardrail Head to the Wood Breakaway Post by inserting 3" washered lag bolts through Mounting Tabs of Guardrail Head and screw washered lag bolts into Wood Breakaway Post.

**G** - 4"X6"X6' Strut Post  
 {w/four 1/2" holes in flanges}  
**H** - 6"X8"X6' Soil Tube



Use tab hole in each of the tabs that is nearest to the center of Wood Breakaway Post. Below are example attachment scenarios.

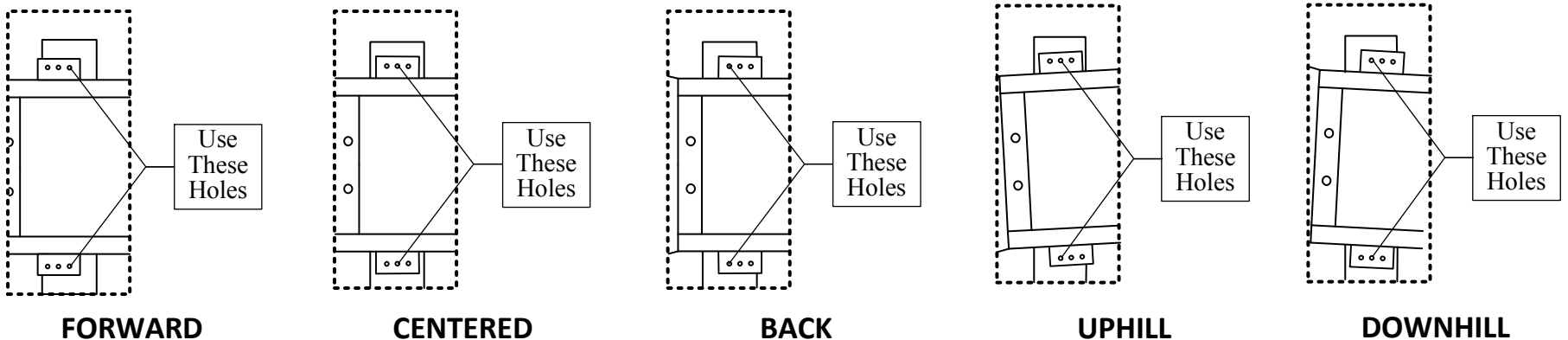

Note: In an alternative, the next tab hole downstream can be used.

**[LEFT SIDE] IXd. INSTALLATION OF GUARDRAIL HEAD**

**SPIG Industry, LLC**

PO Box 2617  
 Abingdon, VA 24212

SHEET NO.

DATE:

L 15 of 20

4/2/20

6. Cut Zip Tie and remove both Zip Tie and Plastic Spacer from within Top Feed Channel of Guardrail Head.

**F** - 4"X6"X6' Guardrail Post  
**G** - 4"X6"X6' Strut Post  
 {w/four ½"holes in flanges}  
**H** - 6"X8"X6' Soil Tube

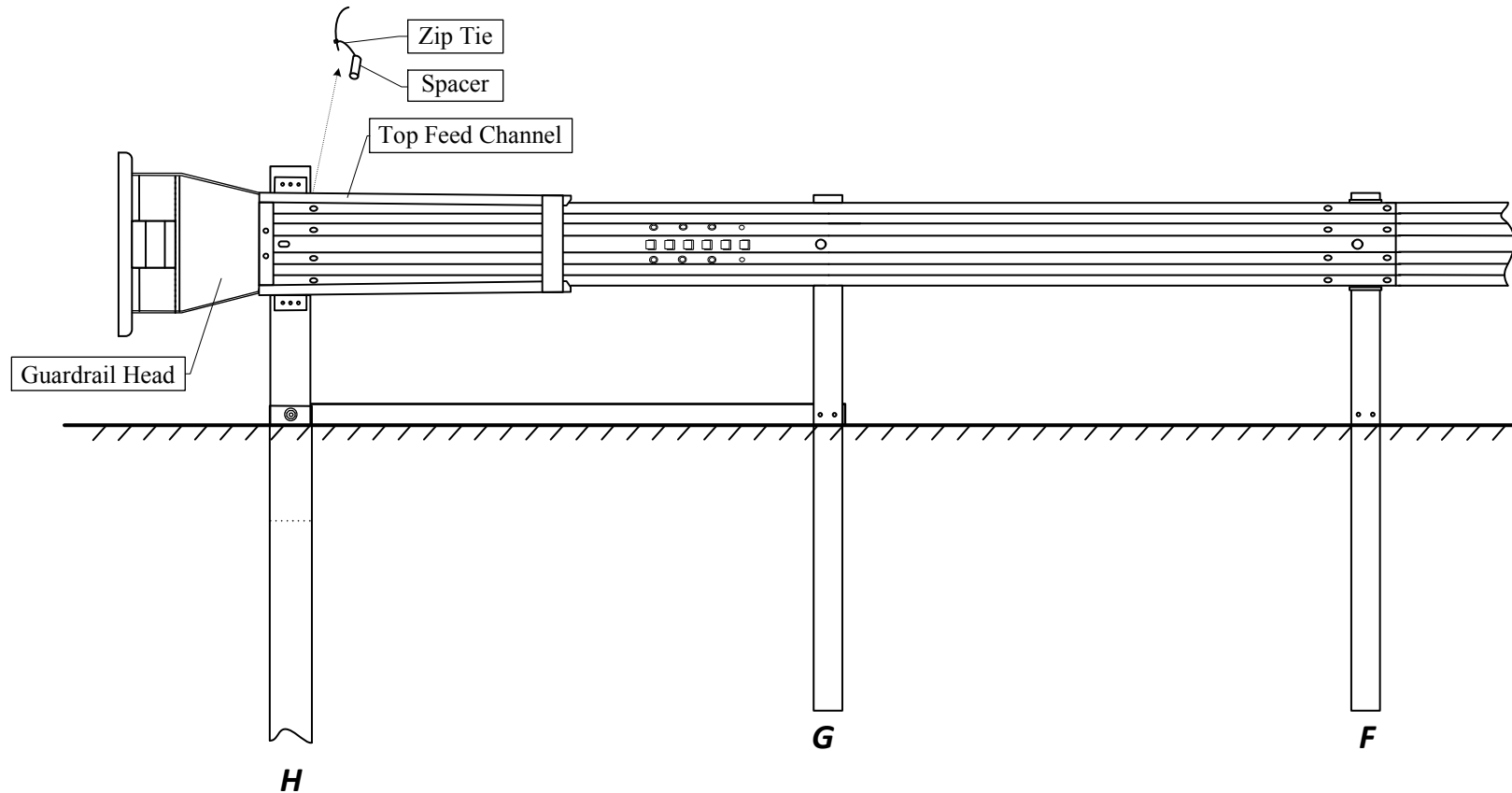

**[LEFT SIDE] IXe. INSTALLATION OF GUARDRAIL HEAD**

**SPIG Industry, LLC**  
 PO Box 2617  
 Abingdon, VA 24212

SHEET NO.

DATE:

L 16 of 20

4/2/20



1. Insert Pipe Sleeve into hole of Wood Breakaway Post.

**F** - 4"X6"X6' Guardrail Post  
**G** - 4"X6"X6' Strut Post  
    {w/four ½"holes in flanges}  
**H** - 6"X8"X6' Soil Tube

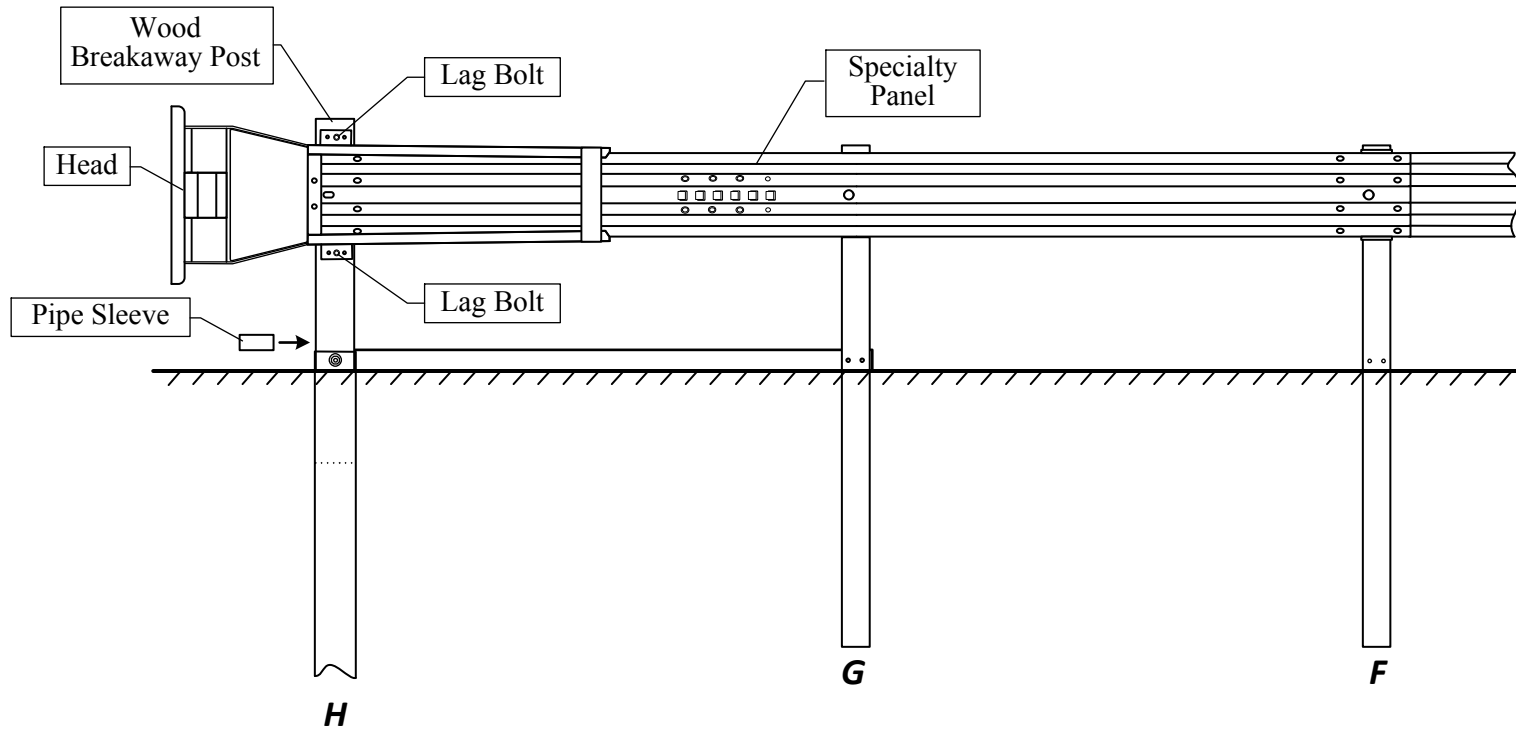

**[LEFT SIDE] Xa. INSTALLATION OF CABLE ANCHOR**

**SPIG Industry, LLC**

PO Box 2617  
Abingdon, VA 24212

SHEET NO.

L 17 of 20

DATE:

4/2/20

2. Thread Cable through Guardrail Grabber and through Pipe Sleeve within Wood Breakaway Post.
3. Attach Cable to Guardrail Grabber using a washer and a nut.
4. Attach Cable to Wood Breakaway Post through Pipe Sleeve and Bearing Plate using a washer and a nut. Position the Bearing Plate such that the two ½" holes of the of the Bearing Plate are on the top. Further, the lip of the bearing plate must be on top of the soil tube and be within the hole of the Wood Breakaway Post.

**F** - 4"X6"X6' Guardrail Post  
**G** - 4"X6"X6' Strut Post  
 {w/four ½"holes in flanges}  
**H** - 6"X8"X6' Soil Tube

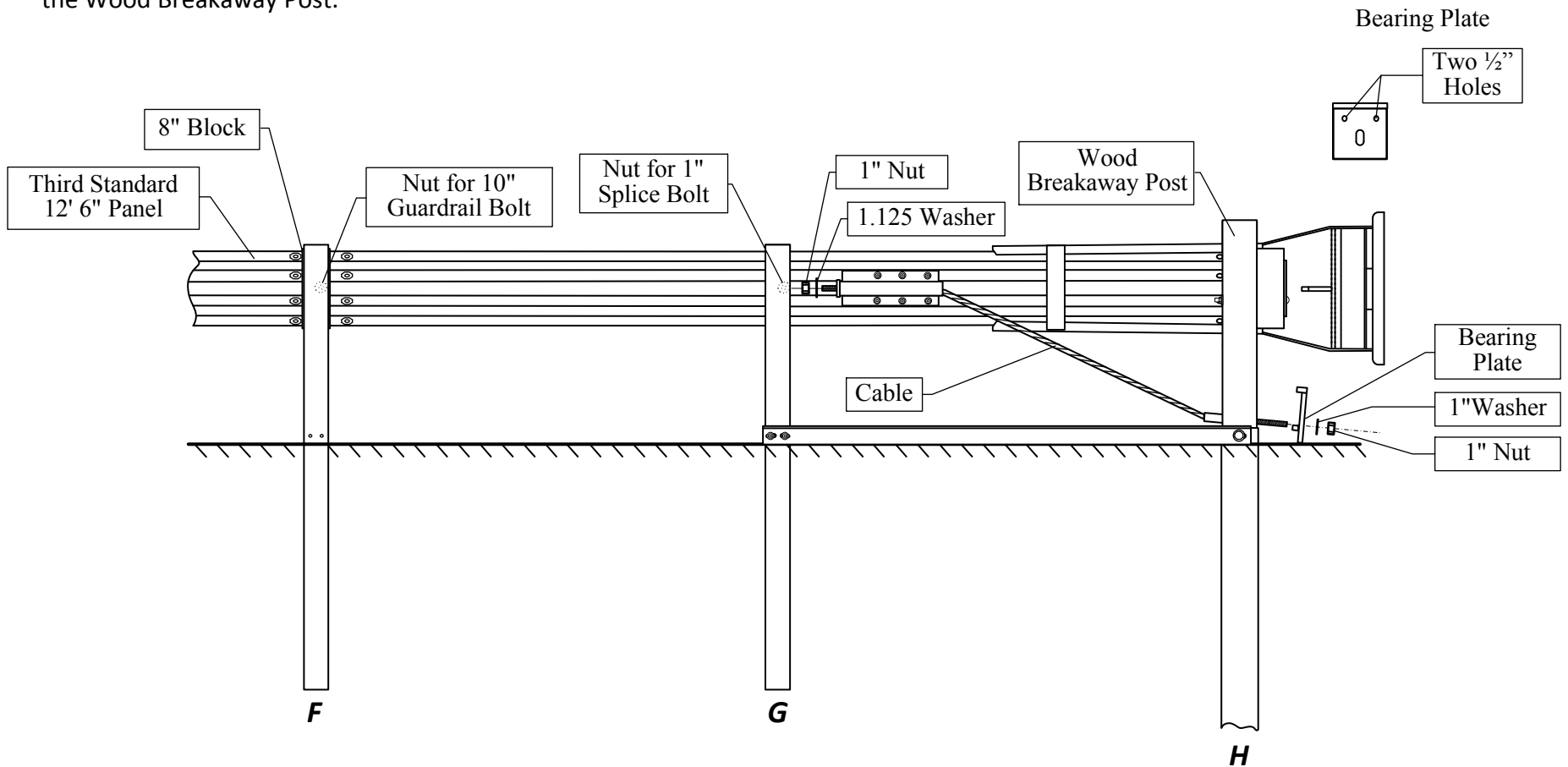

**[LEFT SIDE] Xb. INSTALLATION OF CABLE ANCHOR**

**SPIG Industry, LLC**

PO Box 2617  
 Abingdon, VA 24212

SHEET NO.

DATE:

L 18 of 21

4/2/20

5. Tighten the nuts on the threaded ends of the Cable such that 1-1.25 inches of threading is exposed at the back end of the Guardrail Grabber and the cable becomes taut. Cable should be so taut or tight so as not to deflect more than an inch when kicked.

**F** - 4"X6"X6' Guardrail Post  
**G** - 4"X6"X6' Strut Post  
 {w/four ½" holes in flanges}  
**H** - 6"X8"X6' Soil Tube

**The threaded end of the cable should extend or protrude 1-1.25 inches beyond the nut at the back end of the Guardrail Grabber.**

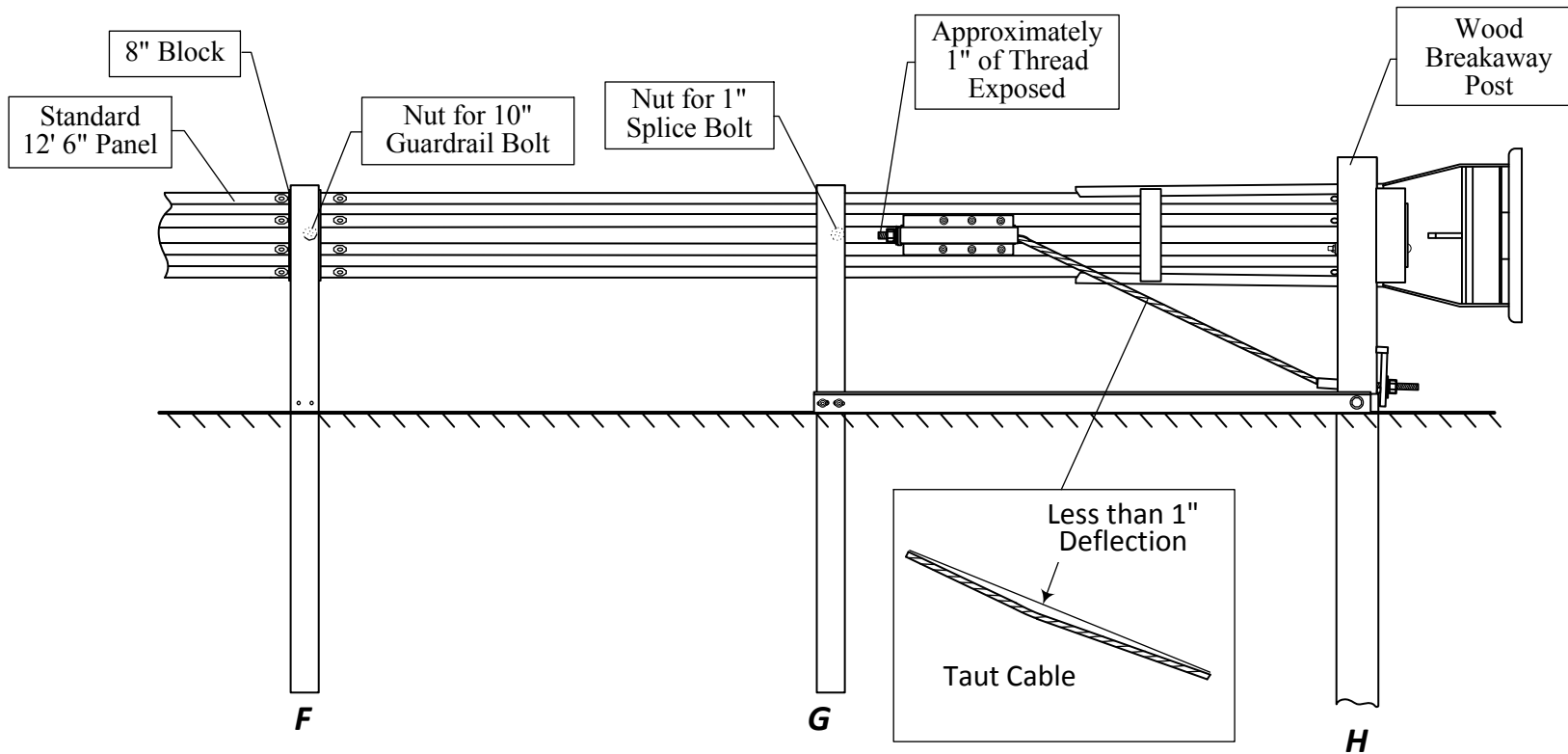

**[LEFT SIDE] Xc. INSTALLATION OF CABLE ANCHOR**

**SPIG Industry, LLC**  
 PO Box 2617  
 Abingdon, VA 24212

SHEET NO.

DATE:

L 19 of 21

4/2/20

6. Insert 3" washered lag screws into the two holes of the Bearing Plate and screw 3" washered lag screws into Wood Breakaway Post.

*H* - 6"X8"X6' Soil Tube

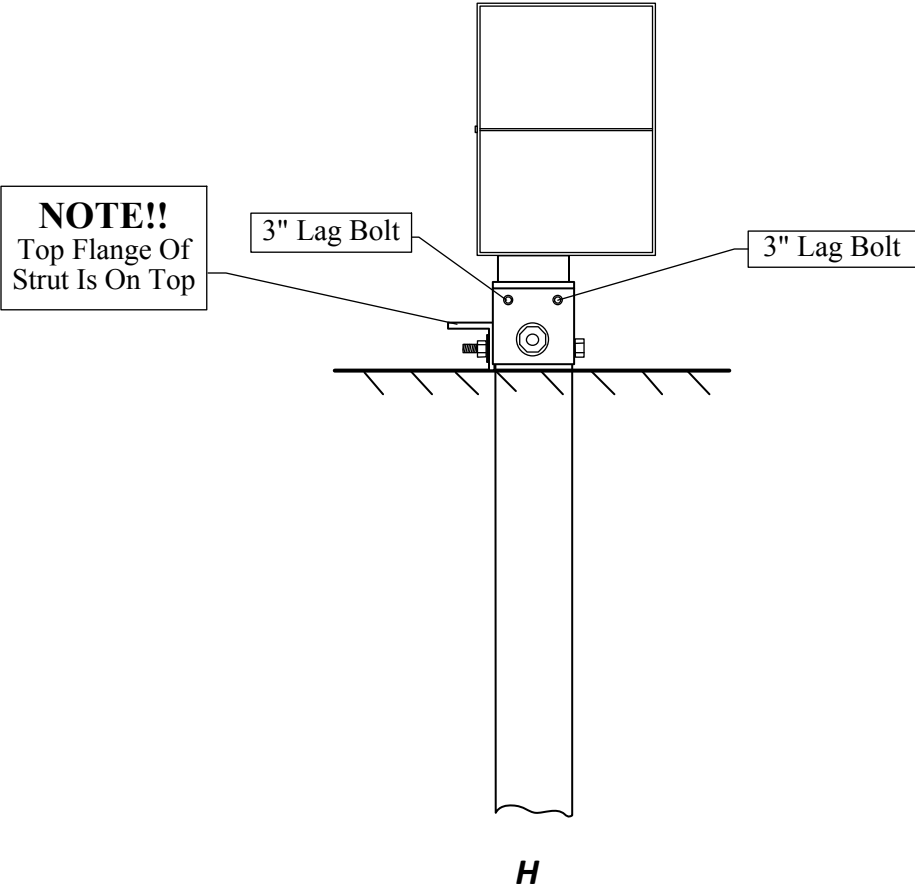

**[LEFT SIDE] Xd. INSTALLATION OF CABLE ANCHOR**

**SPIG Industry, LLC**  
PO Box 2617  
Abingdon, VA 24212

SHEET NO.

DATE:

L 20 of 20

4/2/20

1. Install Guardrail Post A extending ~32 inches above the ground at a spacing of 6'3" from the end of the length of need and inline with the length of need.
2. Install Guardrail Post B extending ~32 inches above the ground at a spacing of 6'3" from Guardrail Post A and inline with Guardrail Post A and the length of need.
3. Install Guardrail Post C extending ~32 inches above the ground at a spacing of 6'3" from Guardrail Post B and inline with Guardrail Post B and Guardrail Post A.
4. Install Guardrail Post D extending ~32 inches above the ground at a spacing of 6'3" from Guardrail Post C and inline with Guardrail Post C and Guardrail Post B.
5. Install Guardrail Post E extending ~32 inches above the ground at a spacing of 6'3" from Guardrail Post D and inline with Guardrail Post D and Guardrail Post C.
6. Install Guardrail Post F extending ~32 inches above the ground at a spacing of 6'3" from Guardrail Post E and inline with Guardrail Post E and Guardrail Post D.
7. Install Strut Post G extending ~32 inches above the ground at a spacing of 6'3" from Guardrail Post F and offset 8" toward road from the line of Guardrail Posts F and E.
8. Install Soil Tube H extending up to 4 inches above the ground at a spacing of 6'3" from Strut Post G and offset 8" toward road from the line of Guardrail Posts F and E.

- A** - 4"X6"X6' Guardrail Post  
{w/four ½"holes in flanges near ground}
- B** - 4"X6"X6' Guardrail Post  
{w/four ½"holes in flanges near ground}
- C** - 4"X6"X6' Guardrail Post  
{w/four ½"holes in flanges near ground}
- D** - 4"X6"X6' Guardrail Post  
{w/four ½"holes in flanges near ground}
- E** - 4"X6"X6' Guardrail Post  
{w/four ½"holes in flanges near ground}
- F** - 4"X6"X6' Guardrail Post  
{w/four ½"holes in flanges near ground}
- G** - 4"X6"X6' Strut Post  
{w/four ½"holes in flanges near ground}
- H** - 6"X8"X6' Soil Tube

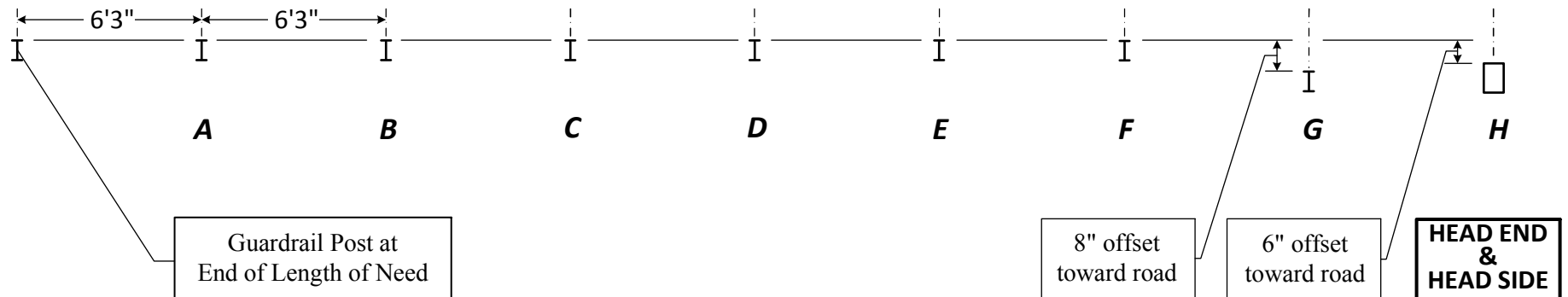

## [RIGHT SIDE] I. INSTALLATION OF POSTS AND TUBE

**SPIG Industry, LLC**

PO Box 2617

Abingdon, VA 24212

SHEET NO.

DATE:

R 1 of 20

4/2/20

1. Insert 50" Wood Breakaway Post into Soil Tube **G** until hole in Soil Tube matches hole in Wood Breakaway post.

**G** - 4"X6"X6' Strut Post  
 {w/four 1/2" holes in flanges near ground}  
**H** - 6"X8"X6' Soil Tube

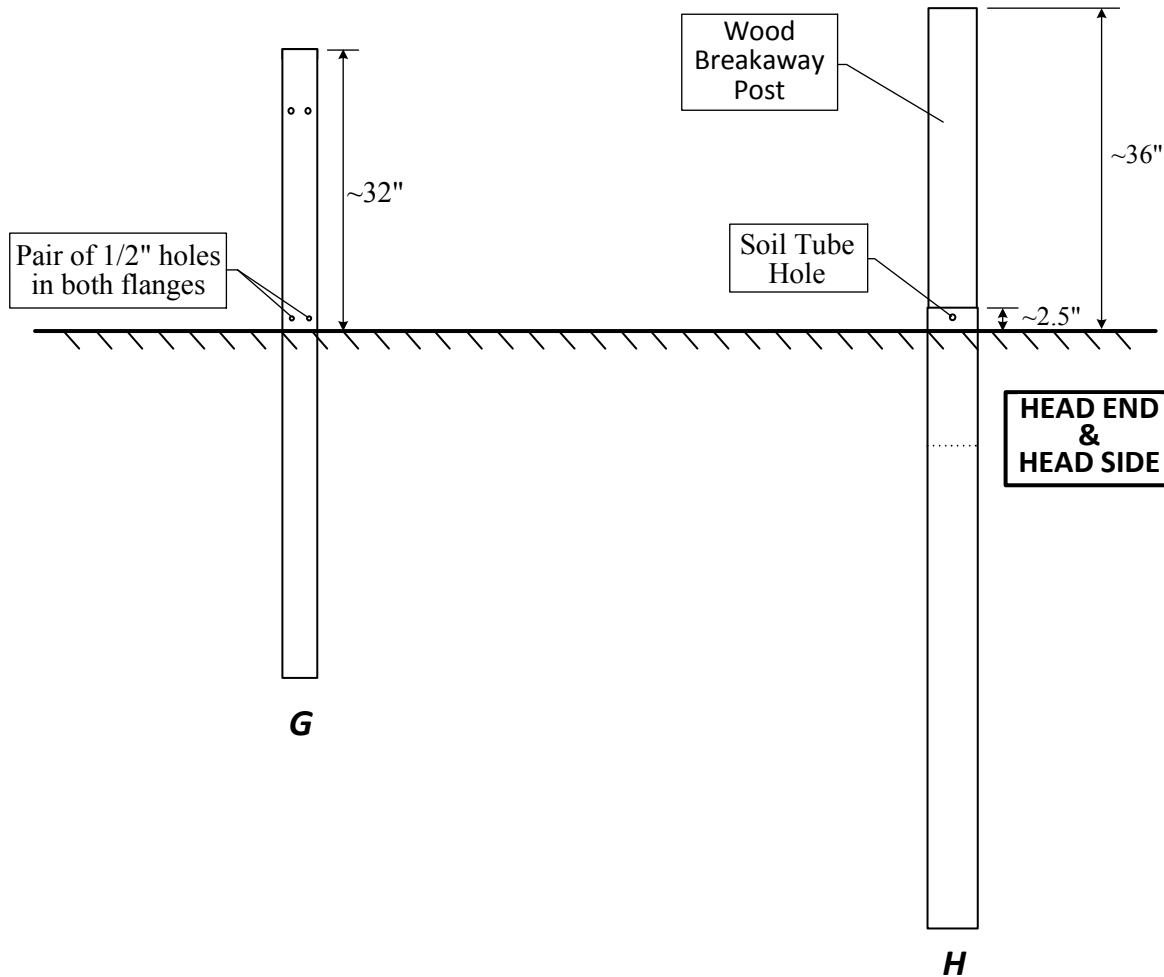

**[RIGHT SIDE] II. INSTALLATION OF 50" WOOD BREAKAWAY POST**

**SPIG Industry, LLC**  
 PO Box 2617  
 Abingdon, VA 24212

SHEET NO.

DATE:

R 2 of 20

4/2/20

1. (Right Road Side) Position Strike Block on Wood Breakaway Post such that lip of Strike Block is on side of Wood Breakaway Post opposite the Head Side of Wood Breakaway Post and then position Strike Plate on Strike Block such that lip of Strike Plate is on head side of Strike Block.
2. (Right Road Side) Insert 14" (or 12") long 5/8" guardrail bolt through the lower hole of the Strike Plate, through the Strike Block, and then the Wood Breakaway Post. Then, put 5/8" washer and 5/8" nut on the 14" (or 12") long 5/8" guardrail bolt.

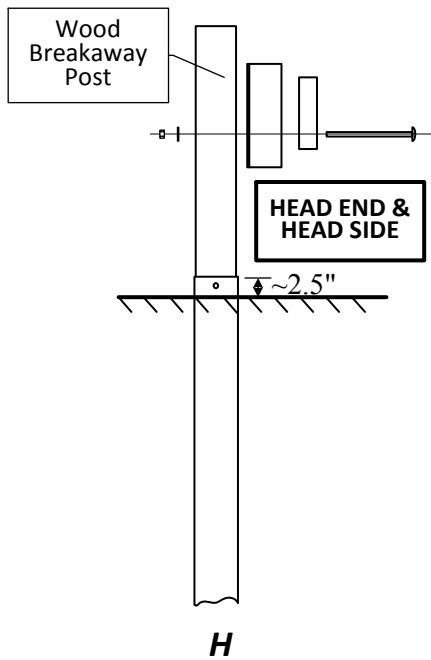

**SIDE VIEW**

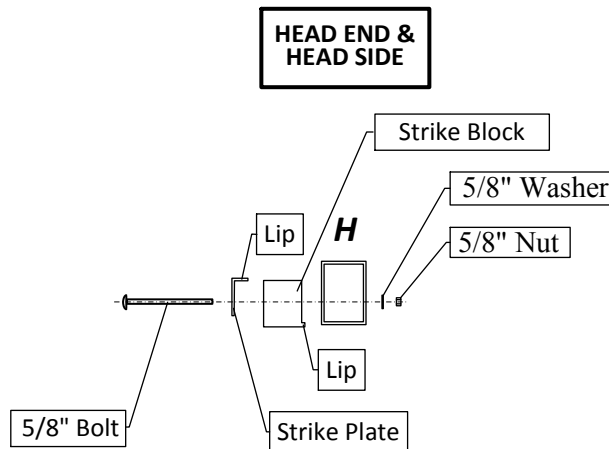

**TOP VIEW**

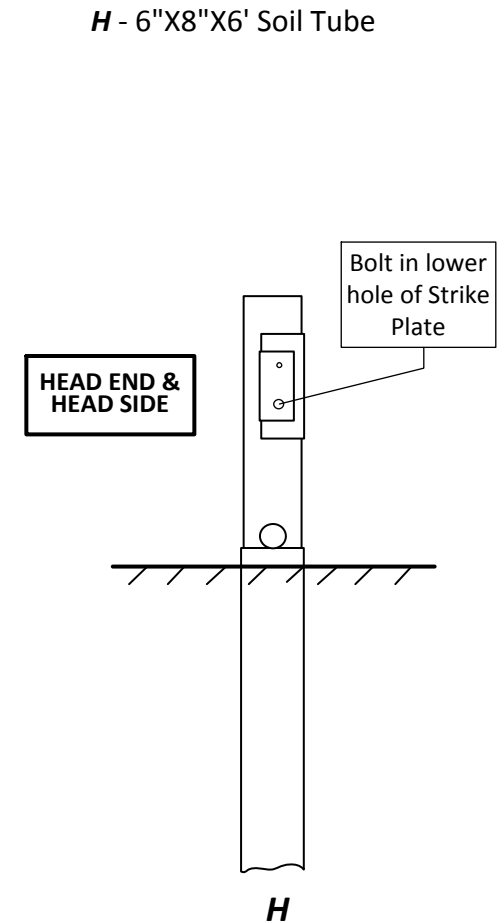

**FRONT VIEW**

**[RIGHT SIDE] IIIa. INSTALLATION OF STRIKE PLATE AND STRIKE BLOCK**

**SPIG Industry, LLC**  
 PO Box 2617  
 Abingdon, VA 24212

SHEET NO.

DATE:

R 3 of 20

4/2/20

3. Tighten 5/8" nut on 14" (or 12") long 5/8" guardrail bolt inserted through the lower hole of the Strike Plate, through the Strike Block, and then the Wood Breakaway Post.

**G** - 4"X6"X6' Strut Post  
 {w/four 1/2" holes in flanges near ground}  
**H** - 6"X8"X6' Soil Tube

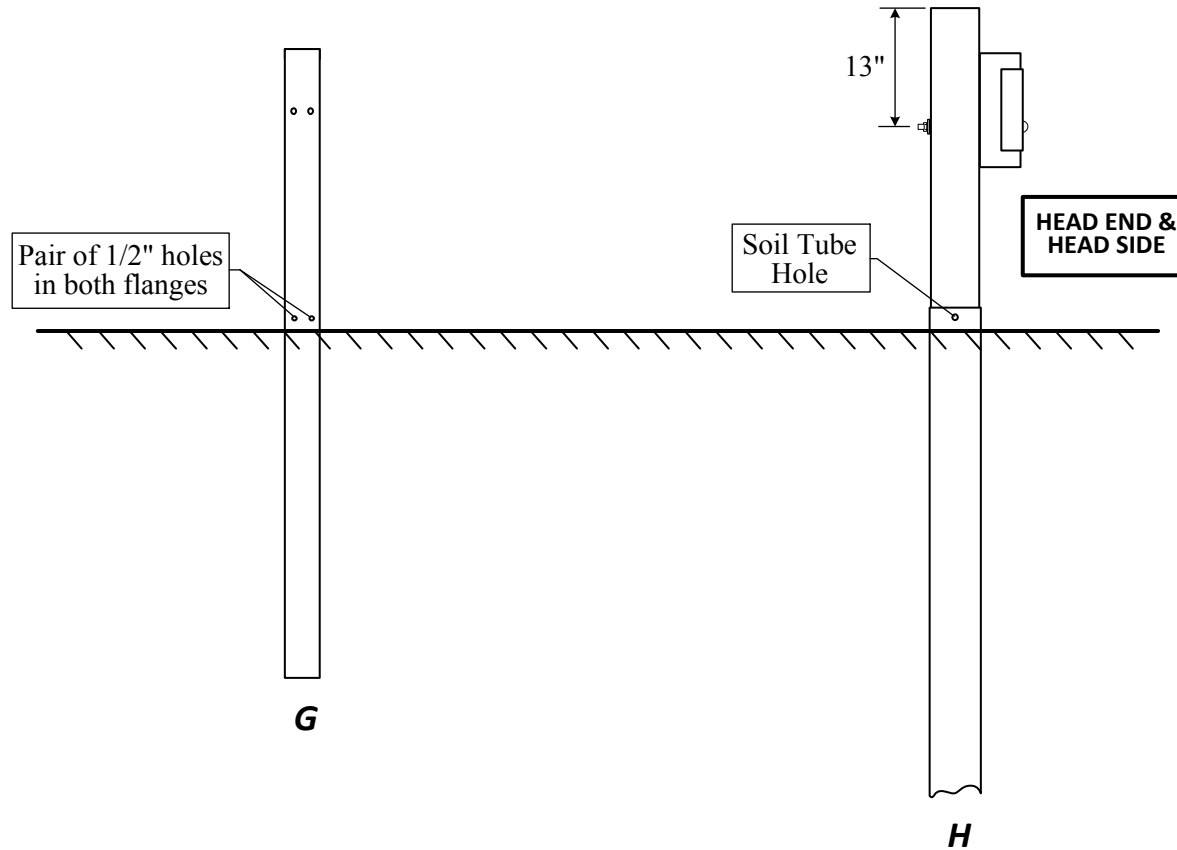

**[RIGHT SIDE] IIIb. INSTALLATION OF STRIKE PLATE AND STRIKE BLOCK**

**SPIG Industry, LLC**  
 PO Box 2617  
 Abingdon, VA 24212

SHEET NO.

DATE:

R 4 of 20

4/2/20



1. Position Strut between Strut Post G and Soil Tube H such that one flange of the Strut is on top and the other flange of the Strut is against Strut Post G and Soil Tube H.
2. Insert washered 2" long 1/2" bolts under the one flange and through both the Strut and Strut Post G. Then, put washers, lock washers and nuts on the 2" long 1/2" bolts to attach the Strut to the Strut Post G.
3. Insert washered 10" long 5/8" bolt under the one flange and through the Strut, Soil Tube H and Wood Breakaway Post. Then, put washers, lock washers and nuts on the 10" long 5/8" bolt to attach the Strut to the Soil Tube H and the Wood Breakaway Post.

**G** - 4"X6"X6' Strut Post  
 {w/four 1/2" holes in flanges near ground}  
**H** - 6"X8"X6' Soil Tube

Note: Alternatively, the washer 2" long 1/2" bolts and/or the 10" long 5/8" bolt can be inserted through in the opposite direction.

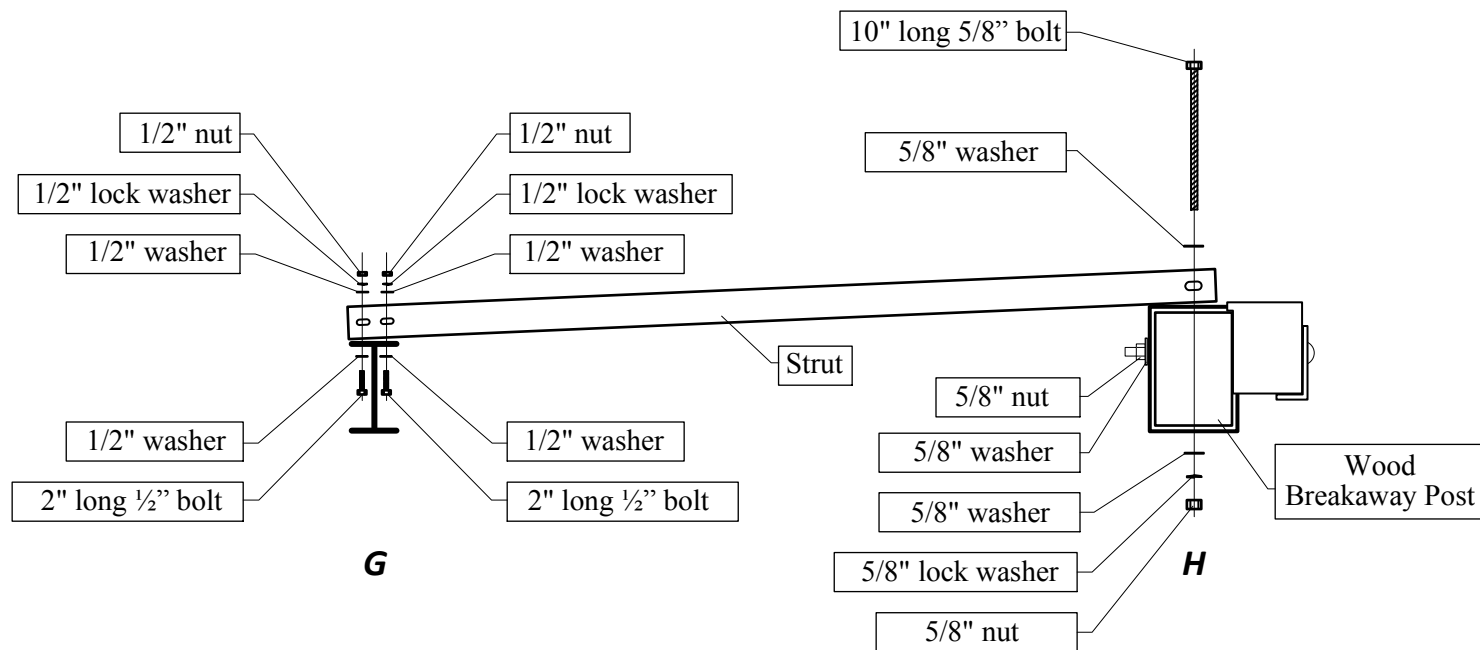

## [RIGHT SIDE] IV. INSTALLATION OF STRUT

**SPIG Industry, LLC**

PO Box 2617  
 Abingdon, VA 24212

SHEET NO.

DATE:

R 5 of 20

5/4/20

1. Attach 9' 4½" Panel to the Guardrail Panel coming from the end of the length of need and to Guardrail Post A through 8" Block Outs using 10" guardrail bolts.
2. Attach 12' 6" Panel to the 9' 4½" Panel using 1" splice bolts.
3. Attach 12' 6" Panel to Guardrail Posts B through D through 8" Block Outs using 10" guardrail bolts.
4. Attach another 12' 6" Panel to the 12' 6" Panel using 1" splice bolts.
5. Attach the other 12' 6" Panel to Guardrail Posts D through F through 8" Block Outs using 10" guardrail bolts.

Notes: 12' 6" Panels can be standard or MGS guardrail.  
Splice bolt holes of the 12' 6" Panels are at Posts.

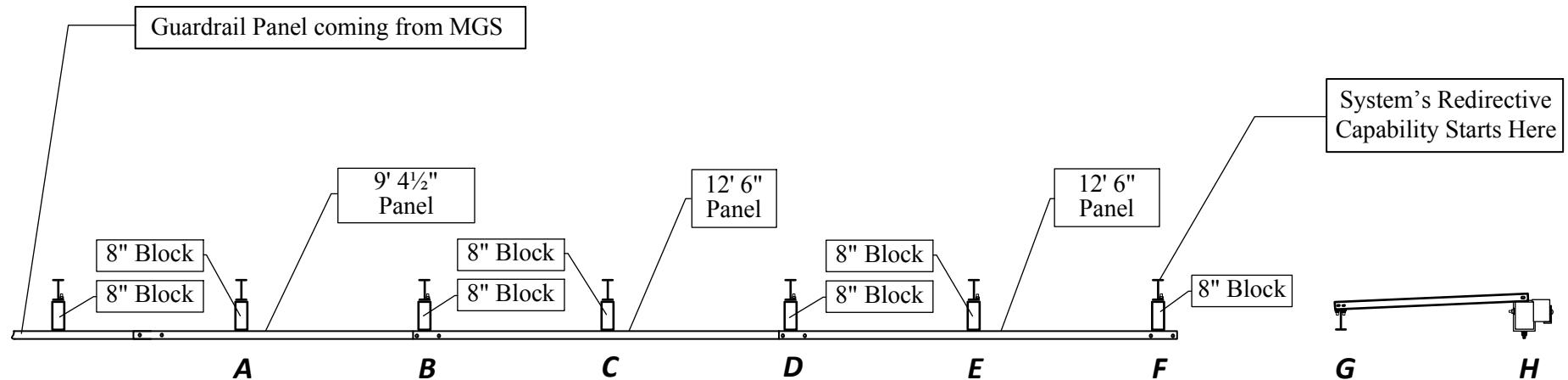

**[LEFT SIDE] V. INSTALLATION OF PANELS (12' 6" & 9' 4½")**

**SPIG Industry, LLC**

PO Box 2617  
Abingdon, VA 24212

SHEET NO.

DATE:

R 6 of 21

4/2/20

7. Attach Specialty Panel to Guardrail Post F through an 8" Block Out using 10" guardrail bolt and to Guardrail Post G .
8. Attach Specialty Panel to the Third 12" 6" Panel using 1" splice bolts.
9. DO NOT ATTACH Specialty Panel to the Wood Breakaway Post in Soil Tube H. The end of the Specialty Panel just lays across the Wood Breakaway Post in Soil Tube H.

- F** - 4"X6"X6' Guardrail Post  
 {w/four ½" holes in flanges near ground}
- G** - 4"X6"X6' Strut Post  
 {w/four ½" holes in flanges near ground}
- H** - 6"X8"X6' Soil Tube

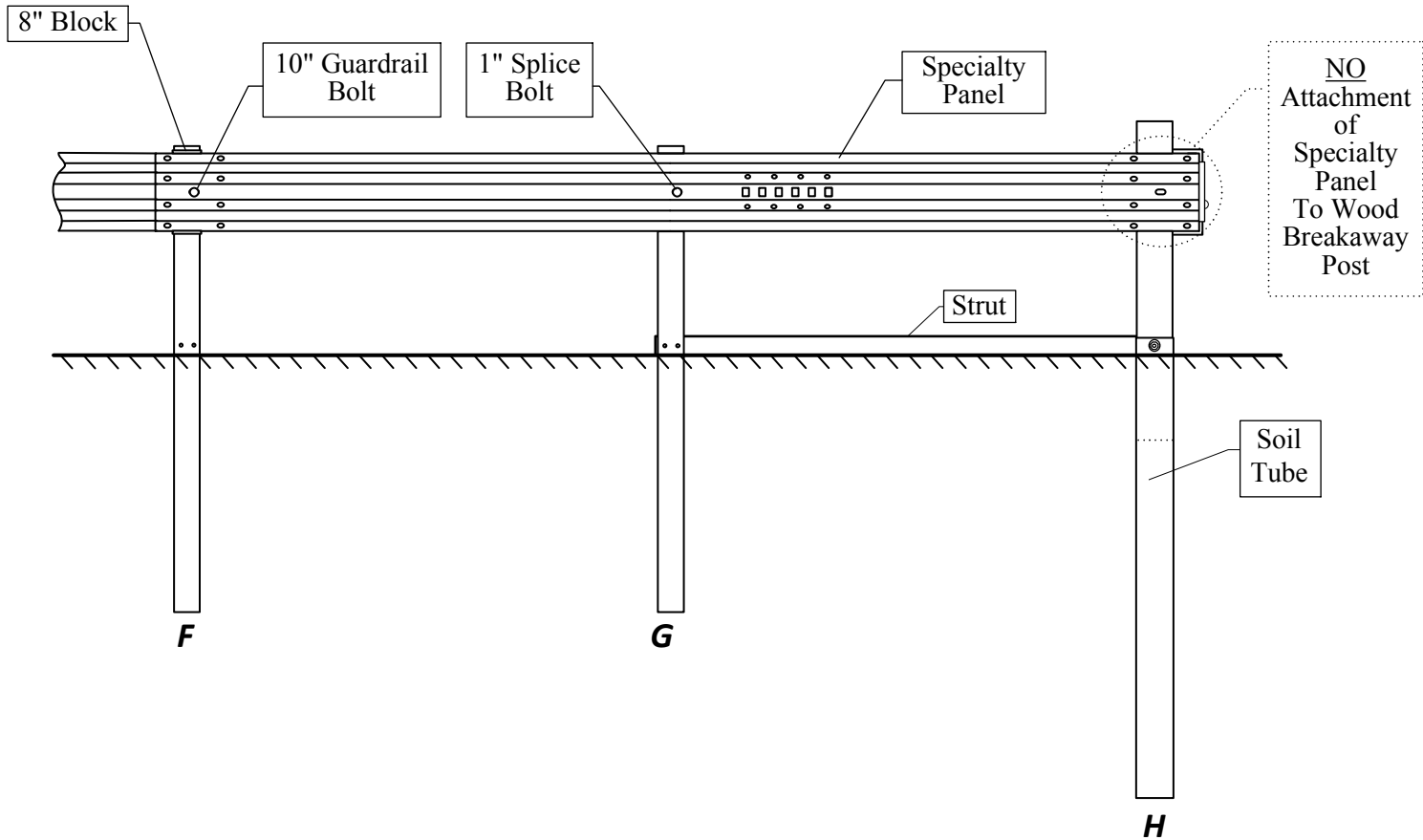

**[RIGHT SIDE] VI. INSTALLATION OF SPECIALTY PANEL**

**SPIG Industry, LLC**  
 PO Box 2617  
 Abingdon, VA 24212

SHEET NO.

DATE:

R 7 of 20

4/2/20

1. Place Reinforcement Panel behind Specialty Panel and align all of the square holes of the Reinforcement Panel correspondingly to all of the square holes in the Specialty Panel such that the Reinforcement Panel is positioned on the back side of the Specialty Panel with the round bolt holes of the Specialty Panel corresponding to the oblong bolt holes of the Reinforcement Panel.
2. Insert washered 1.25" long  $\frac{1}{2}$ " bolts from the front side of the Specialty Panel through the round holes of the Specialty Panel and the oblong holes of the Reinforcement Panel. Then, put washers, lock washers and nuts on ends of the 1" long  $\frac{1}{2}$ " bolts outside of the Reinforcement Panel, which is on the back side of the Specialty Panel.

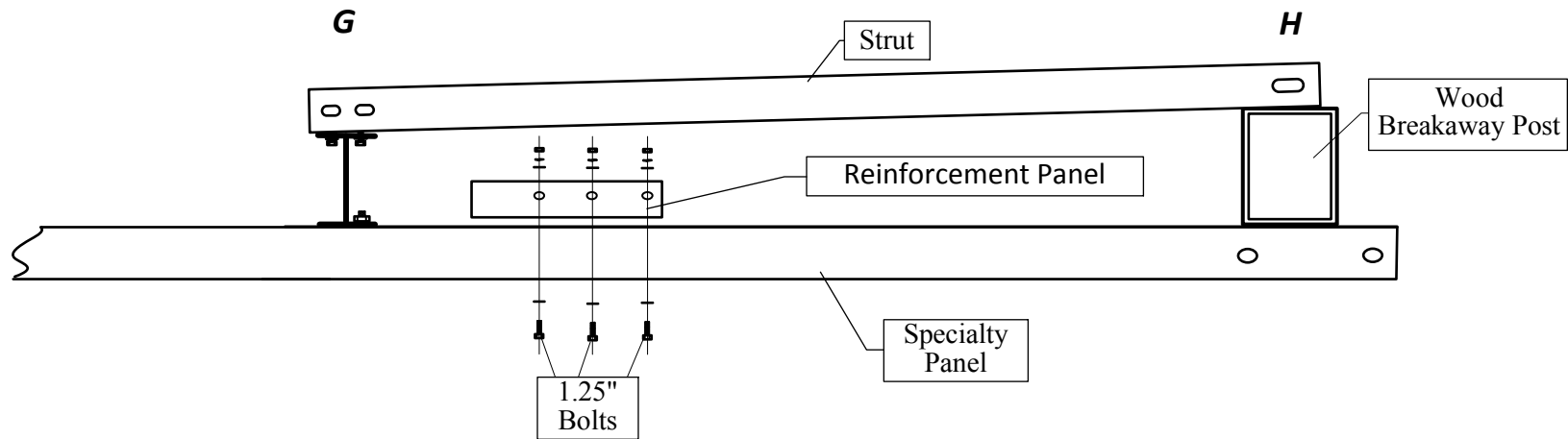

**[RIGHT SIDE] VII. INSTALLATION OF REINFORCEMENT PANEL**

**SPIG Industry, LLC**

PO Box 2617  
Abingdon, VA 24212

SHEET NO.

DATE:

R 8 of 20

4/2/20

1. Insert rectangular-shaped pegs of Guardrail grabber into corresponding rectangular holes in both the Reinforcement Panel and the Specialty Panel with the teeth of the Guardrail Grabber pointing toward the front end of the specialty panel.

**G** - 4"X6"X6' Strut Post  
 {w/four ½"holes in flanges}  
**H** - 6"X8"X6' Soil Tube

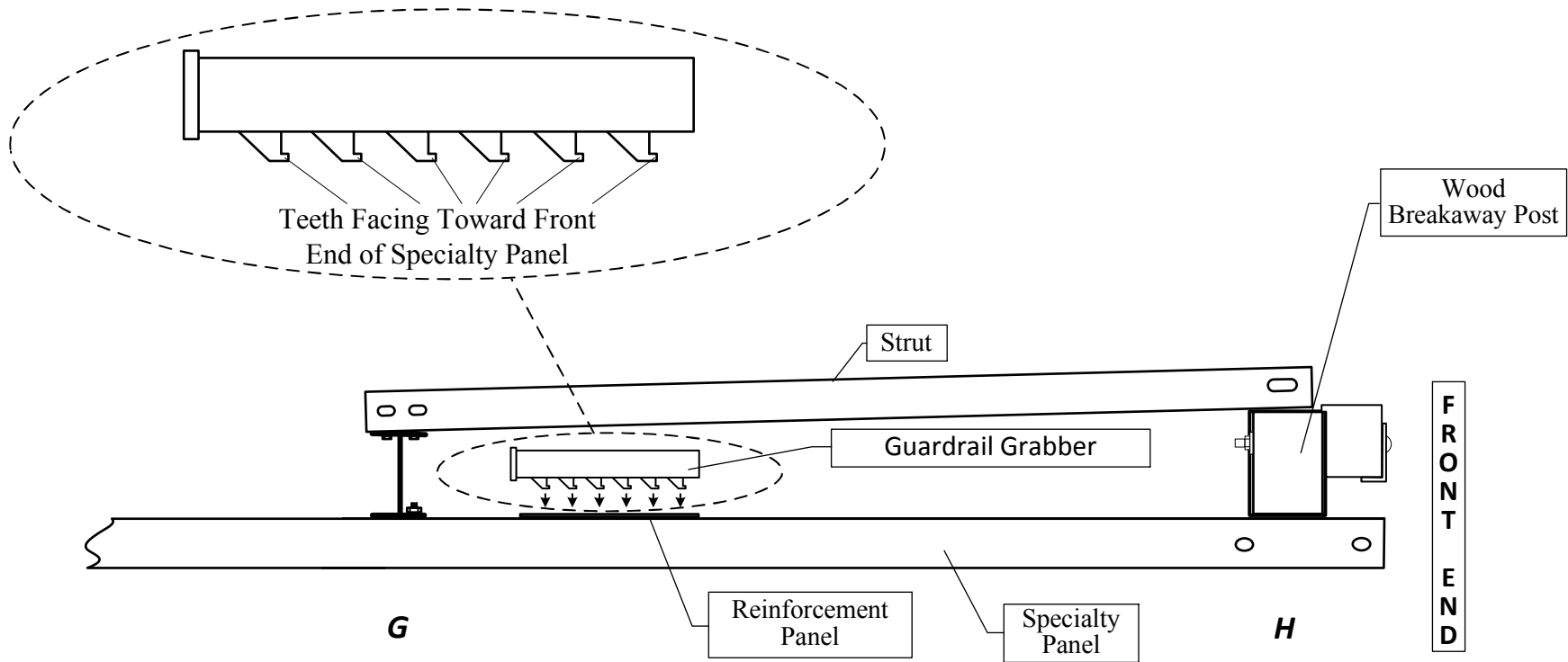

**[RIGHT SIDE] VIIIa. INSTALLATION OF GUARDRAIL GRABBER**

**SPIG Industry, LLC**  
 PO Box 2617  
 Abingdon, VA 24212

SHEET NO.

DATE:

R 9 of 20

4/2/20

2. After insertion of the Guardrail Grabber into the Reinforcement Plate, slide Guardrail Grabber forward toward the front end of the Specialty Panel such that the teeth of the Guardrail Grabber lock onto the front side (or road side) of the specialty panel. A hammer may be used to assist in sliding the Guardrail Grabber forward toward the front end of the Specialty Panel.

**F** - 4"X6"X6' Guardrail Post  
**G** - 4"X6"X6' Strut Post  
 {w/four ½" holes in flanges}  
**H** - 6"X8"X6' Soil Tube

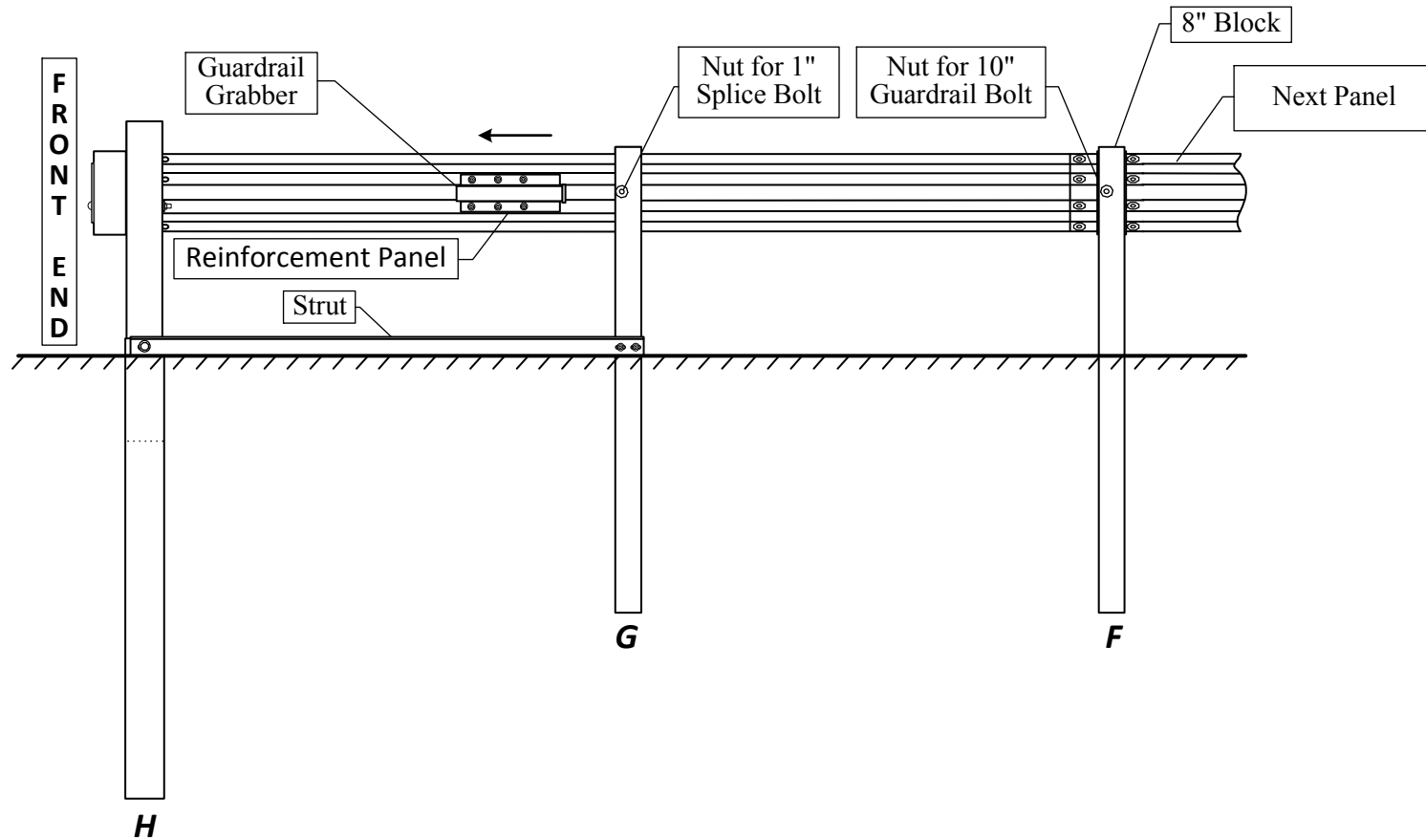

[RIGHT SIDE] VIIIb. INSTALLATION OF GUARDRAIL GRABBER

**SPIG Industry, LLC**

PO Box 2617  
 Abingdon, VA 24212

SHEET NO.

DATE:

R 10 of 20

4/2/20

4. After sliding the Guardrail Grabber forward toward the front end of the Specialty Panel Specialty Panel, tighten the 1" bolts attaching the Reinforcement Panel to the Specialty such that the locknuts are completely crushed and then at least another half turn.

**F** - 4"X6"X6' Guardrail Post  
**G** - 4"X6"X6' Strut Post  
 {w/four ½" holes in flanges}  
**H** - 6"X8"X6' Soil Tube

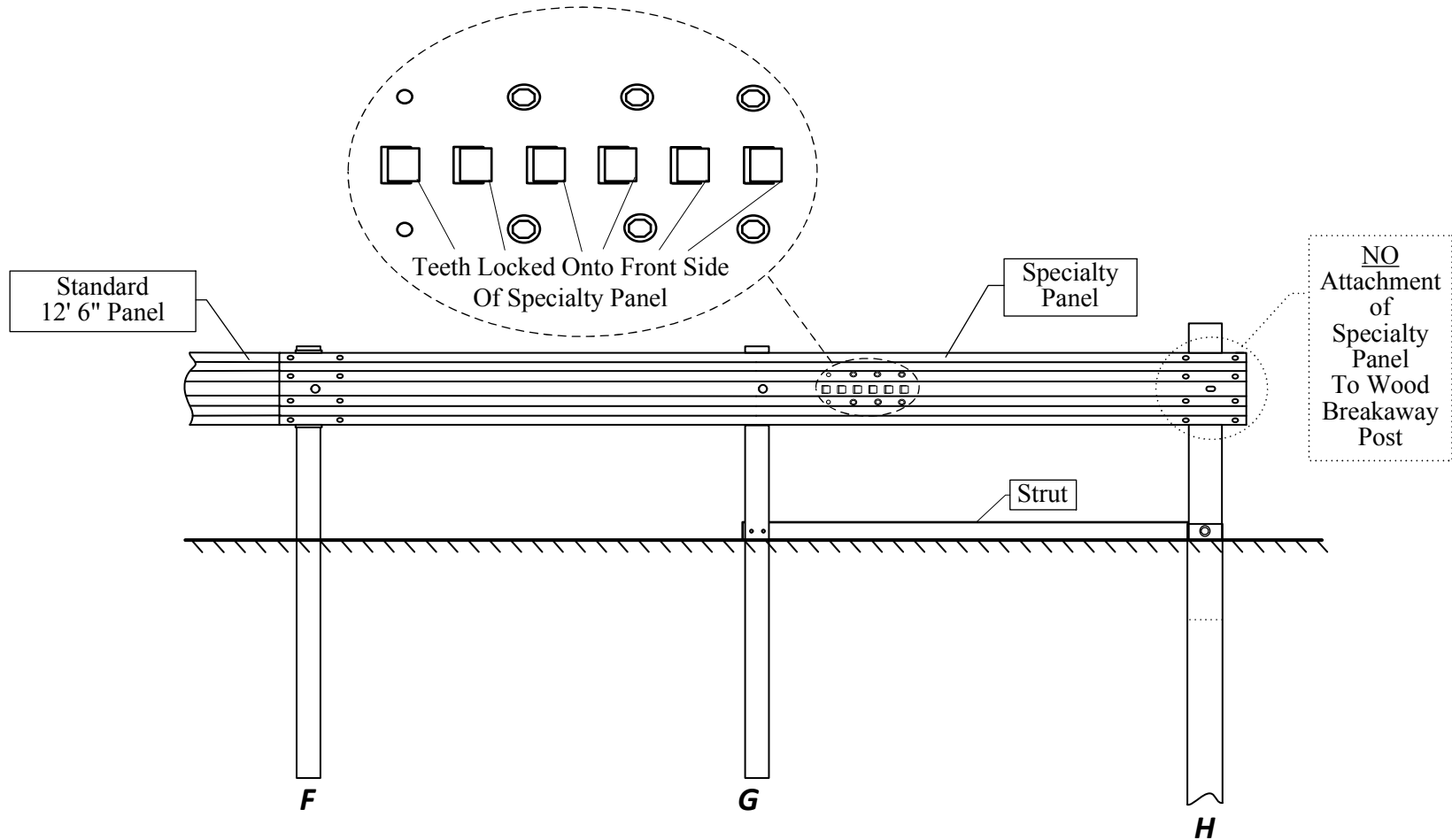

[RIGHT SIDE] VIIIc. INSTALLATION OF GUARDRAIL GRABBER

**SPIG Industry, LLC**

PO Box 2617  
 Abingdon, VA 24212

SHEET NO.

DATE:

R 11 of 20

4/2/20

1. Insert Zip Tie through Plastic Spacer and zip tie plastic spacer into the top feed channel downstream of top mounting tab.

**F** - 4"X6"X6' Guardrail Post  
**G** - 4"X6"X6' Strut Post  
 {w/four 1/2" holes in flanges}  
**H** - 6"X8"X6' Soil Tube

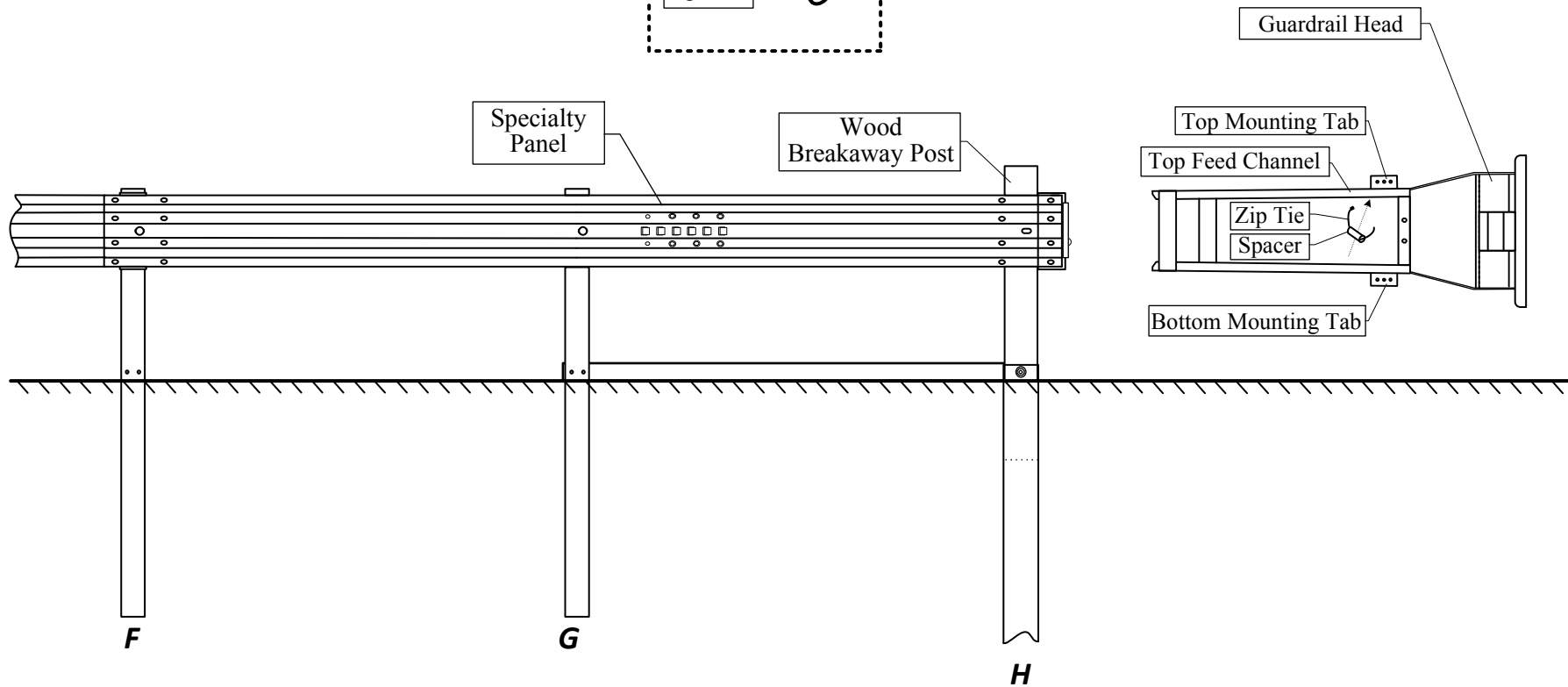
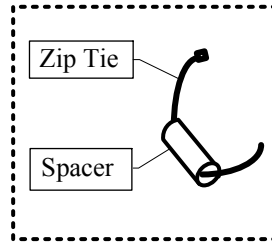

[RIGHT SIDE] IXa. INSTALLATION OF GUARDRAIL HEAD

**SPIG Industry, LLC**  
 PO Box 2617  
 Abingdon, VA 24212

SHEET NO.

DATE:

R 12 of 20

4/2/20



2. Tighten Zip Tie such that plastic spacer is within the top feed channel downstream of top mounting tab.
3. Slide Guardrail Head onto Specialty Panel.

**F** - 4"X6"X6' Guardrail Post  
**G** - 4"X6"X6' Strut Post  
 {w/four 1/2" holes in flanges}  
**H** - 6"X8"X6' Soil Tube

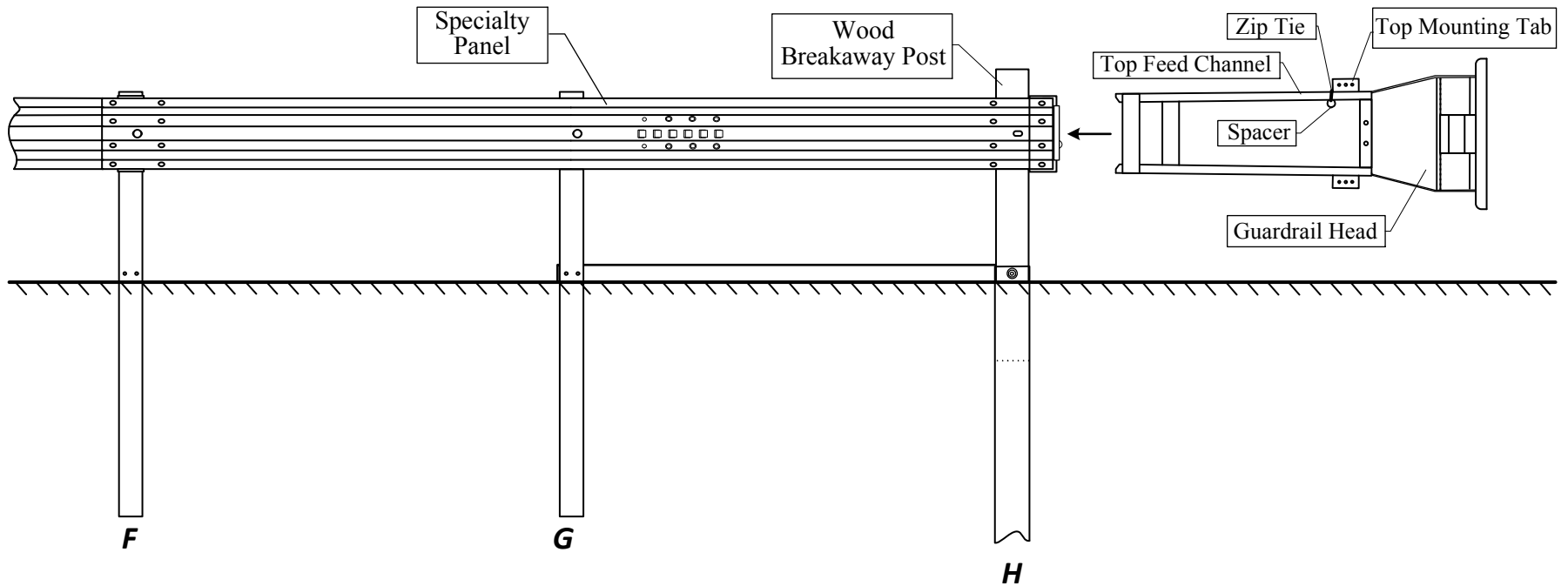

[RIGHT SIDE] IXb. INSTALLATION OF GUARDRAIL HEAD

**SPIG Industry, LLC**  
 PO Box 2617  
 Abingdon, VA 24212

SHEET NO.

DATE:

13 of 20

4/2/20

4. Slide the Guardrail Head onto the Specialty Rail until the Guardrail Head is stopped by the Specialty Panel. Note that the Rail Mounting Hole of the Specialty Panel should be centrally positioned between the Viewing Holes of the Guardrail Head and that the Top and Bottom Mounting Tabs are directly over each other.

**F** - 4"X6"X6' Guardrail Post  
**G** - 4"X6"X6' Strut Post  
 {w/four ½" holes in flanges}  
**H** - 6"X8"X6' Soil Tube

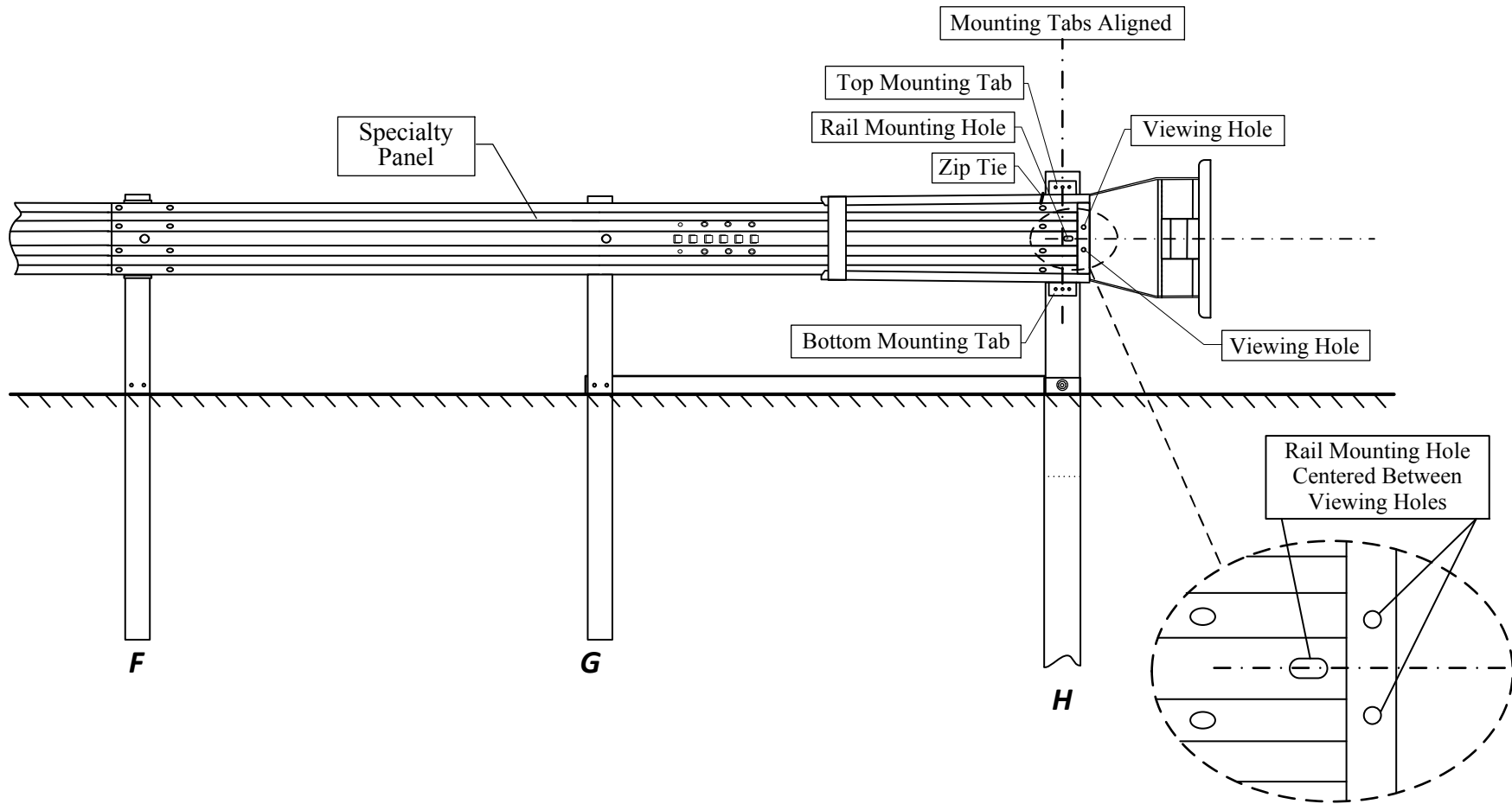

**[RIGHT SIDE] IXc. INSTALLATION OF GUARDRAIL HEAD**

**SPIG Industry, LLC**  
 PO Box 2617  
 Abingdon, VA 24212

SHEET NO.

DATE:

R 14 of 20

4/2/20

5. Attach upper and lower Mounting Tabs of Guardrail Head to the Wood Breakaway Post by inserting 3" washered lag bolts through Mounting Tabs of Guardrail Head and screw washered lag bolts into Wood Breakaway Post.

**G** - 4"X6"X6' Strut Post  
 {w/four 1/2" holes in flanges}  
**H** - 6"X8"X6' Soil Tube

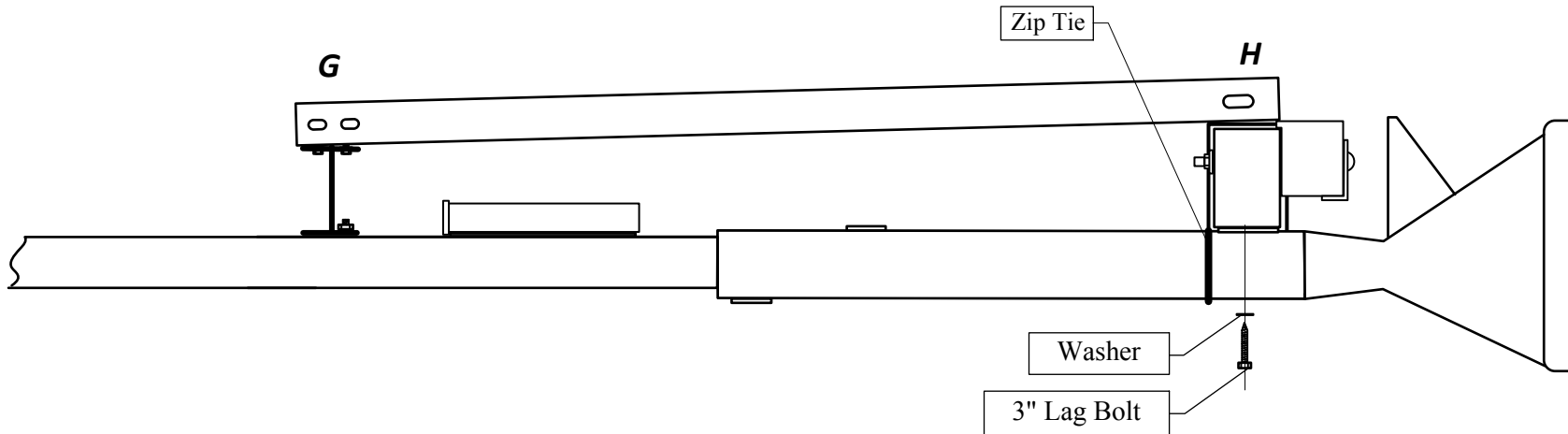

Use tab hole in each of the tabs that is nearest to the center of Wood Breakaway Post. Below are example attachment scenarios.

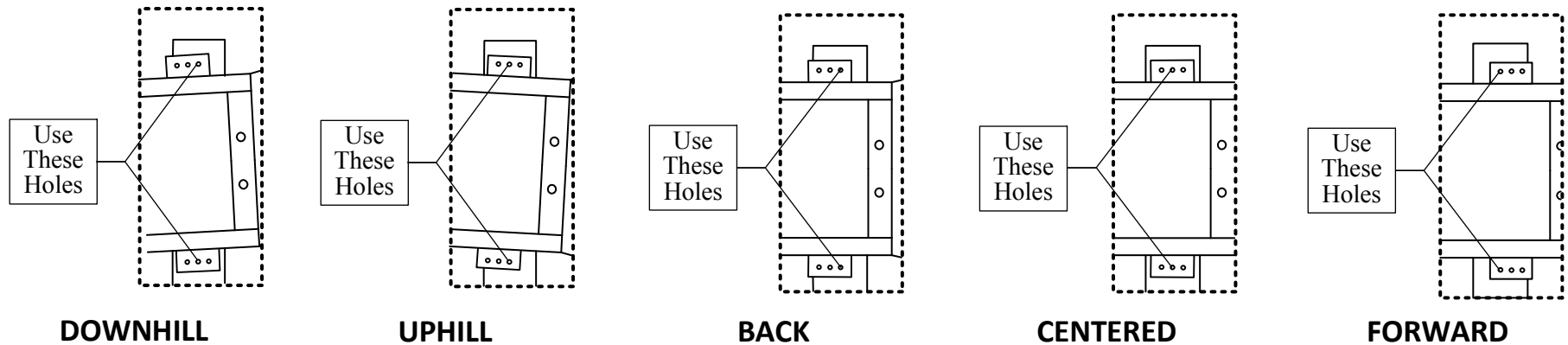

Note: In an alternative, the next tab hole downstream can be used.

## [RIGHT SIDE] IXd. INSTALLATION OF GUARDRAIL HEAD

**SPIG Industry, LLC**  
 PO Box 2617  
 Abingdon, VA 24212

SHEET NO.

DATE:

R 15 of 20

4/2/20

6. Cut Zip Tie and remove both Zip Tie and Plastic Spacer from within Top Feed Channel of Guardrail Head.

- F** - 4"X6"X6' Guardrail Post
- G** - 4"X6"X6' Strut Post  
    {w/four ½" holes in flanges}
- H** - 6"X8"X6' Soil Tube

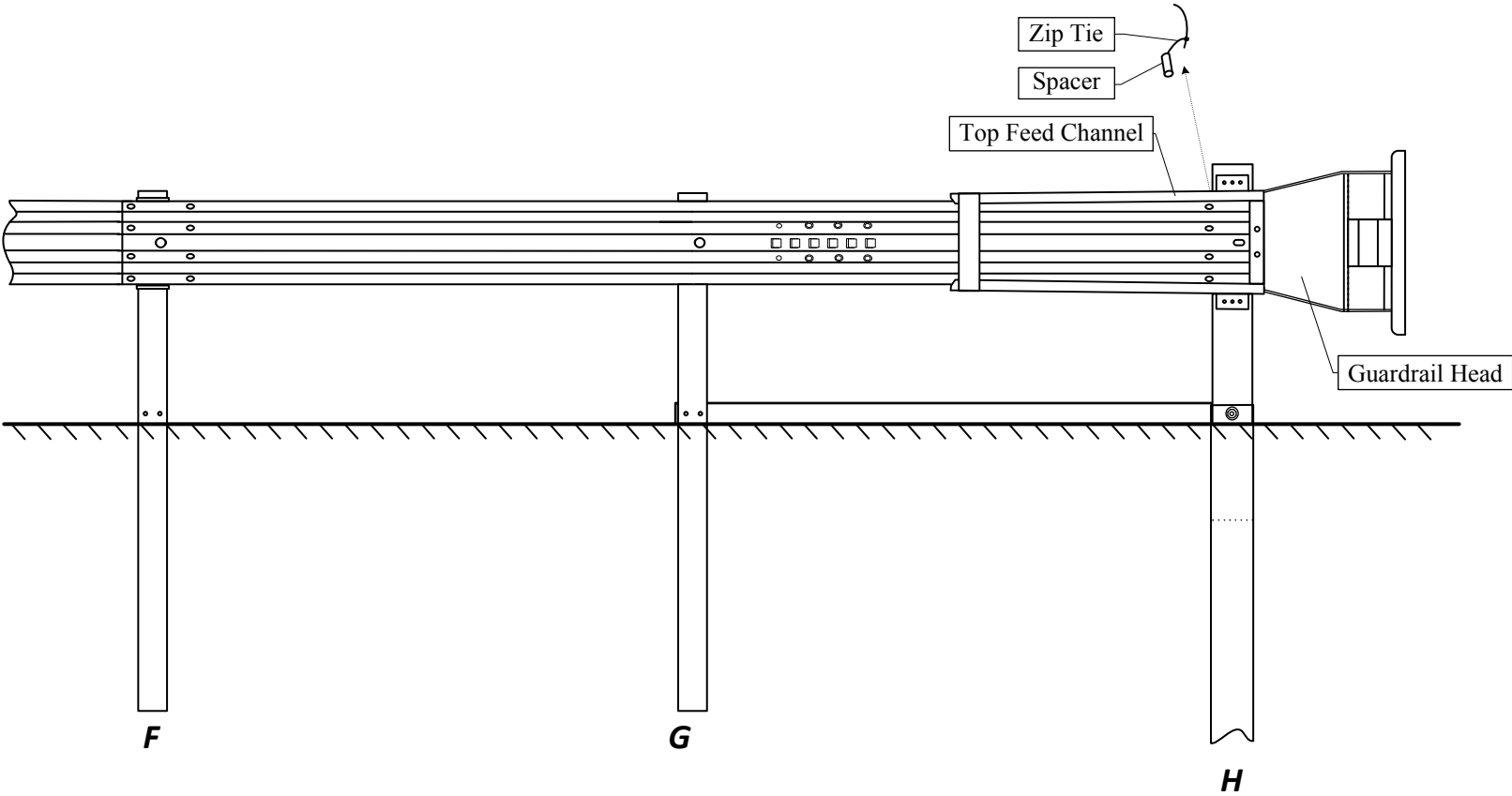

[RIGHT SIDE] IXe. INSTALLATION OF GUARDRAIL HEAD

**SPIG Industry, LLC**  
 PO Box 2617  
 Abingdon, VA 24212

SHEET NO.	DATE:
R 16 of 20	4/2/20

1. Insert Pipe Sleeve into hole of Wood Breakaway Post.

- F** - 4"X6"X6' Guardrail Post
- G** - 4"X6"X6' Strut Post  
 {w/four ½" holes in flanges}
- H** - 6"X8"X6' Soil Tube

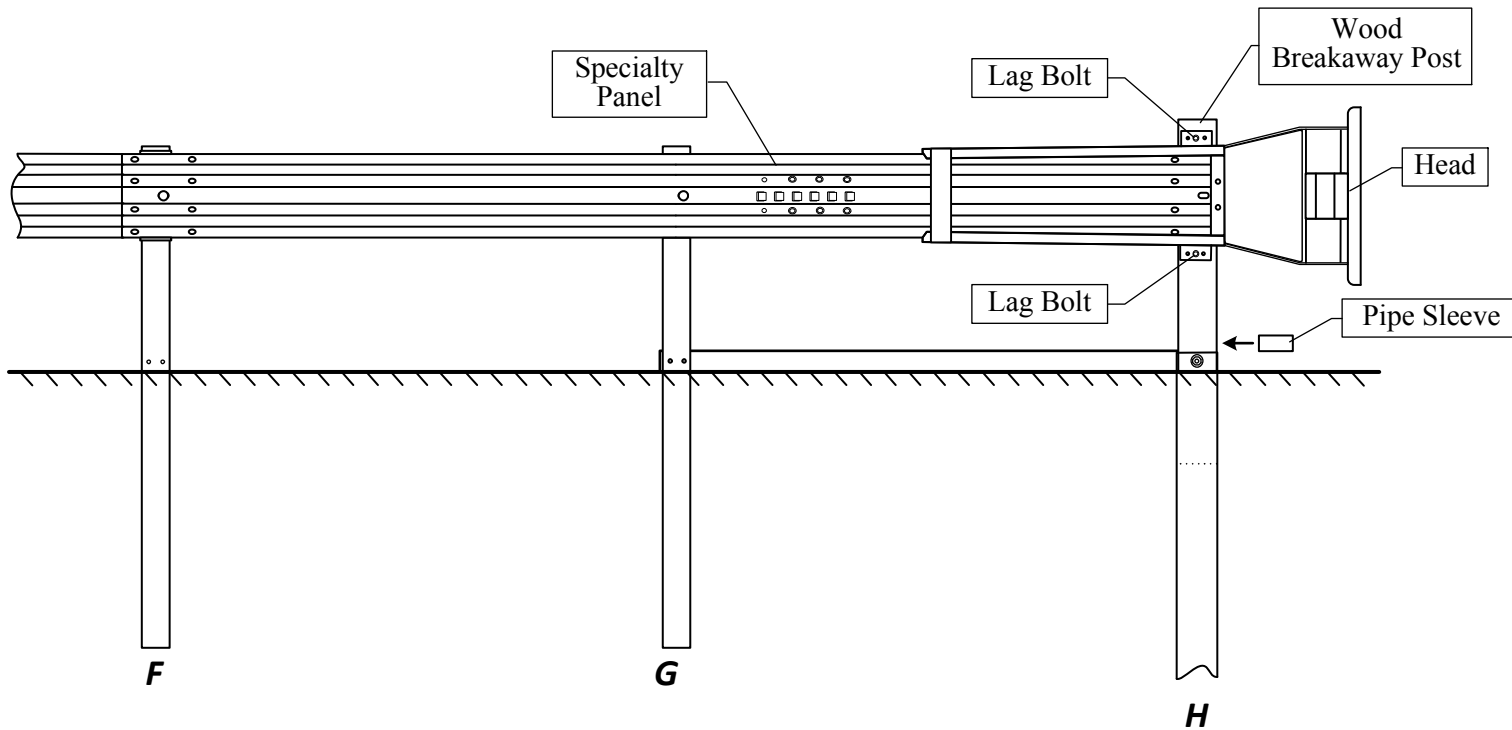

**[RIGHT SIDE] Xa. INSTALLATION OF CABLE ANCHOR**

**SPIG Industry, LLC**  
 PO Box 2617  
 Abingdon, VA 24212

SHEET NO.

DATE:

R 17 of 20

4/2/20

2. Thread Cable through Guardrail Grabber and through Pipe Sleeve within Wood Breakaway Post.
3. Attach Cable to Guardrail Grabber using a washer and a nut.
4. Attach Cable to Wood Breakaway Post through Pipe Sleeve and Bearing Plate using a washer and a nut. Position the Bearing Plate such that the two ½" holes of the of the Bearing Plate are on the top. Further, the lip of the bearing plate must be on top of the soil tube and be within the hole of the Wood Breakaway Post.

**F** - 4"X6"X6' Guardrail Post  
**G** - 4"X6"X6' Strut Post  
 {w/four ½" holes in flanges}  
**H** - 6"X8"X6' Soil Tube

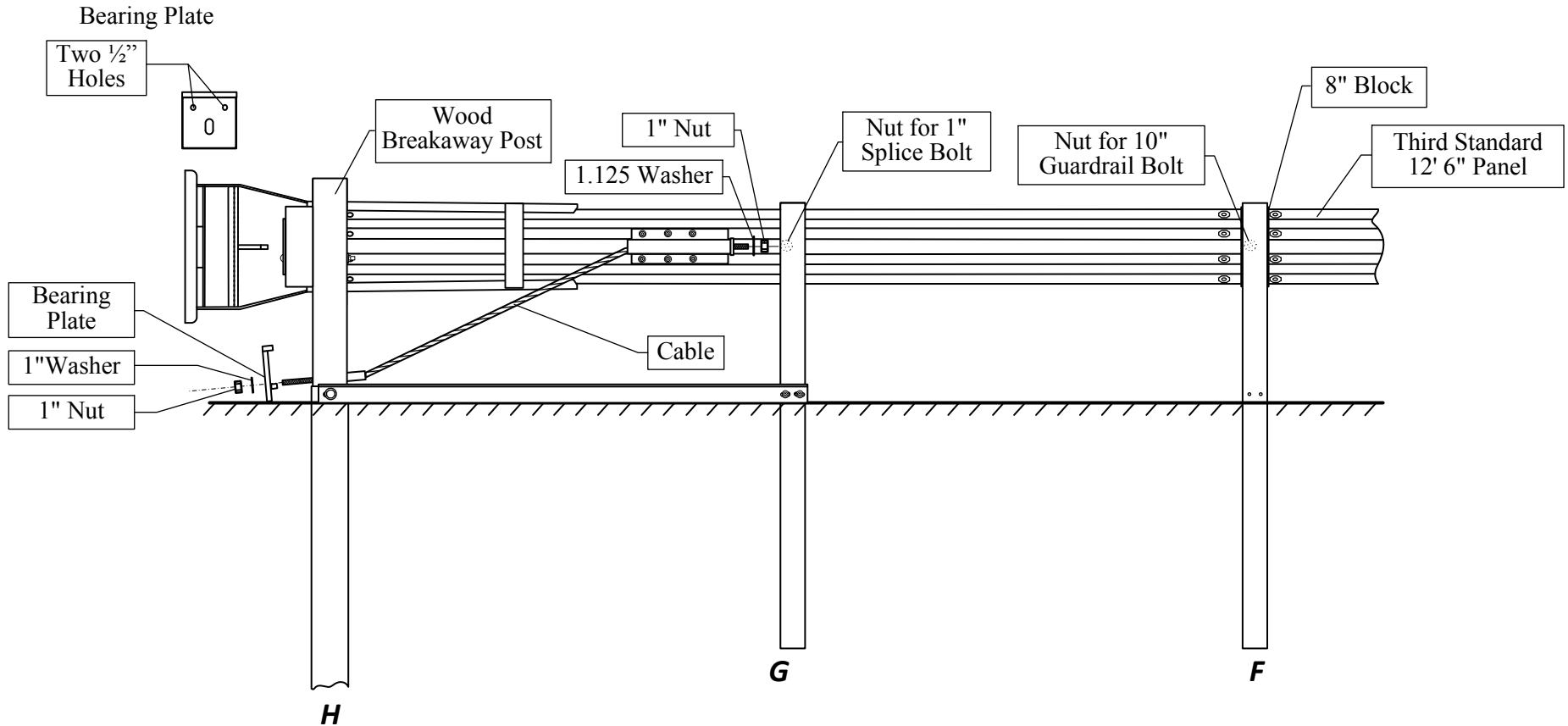

**[RIGHT SIDE] Xb. INSTALLATION OF CABLE ANCHOR**

**SPIG Industry, LLC**  
 PO Box 2617  
 Abingdon, VA 24212

SHEET NO.

DATE:

R 18 of 20

4/2/20

5. Tighten the nuts on the threaded ends of the Cable such that 1-1.25 inches of threading is exposed at the back end of the Guardrail Grabber and the cable becomes taut. Cable should be so taut or tight so as not to deflect more than an inch when kicked.

**F** - 4"X6"X6' Guardrail Post  
**G** - 4"X6"X6' Strut Post  
 {w/four ½" holes in flanges}  
**H** - 6"X8"X6' Soil Tube

**The threaded end of the cable should extend or protrude 1-1.25 inches beyond the nut at the back end of the Guardrail Grabber.**

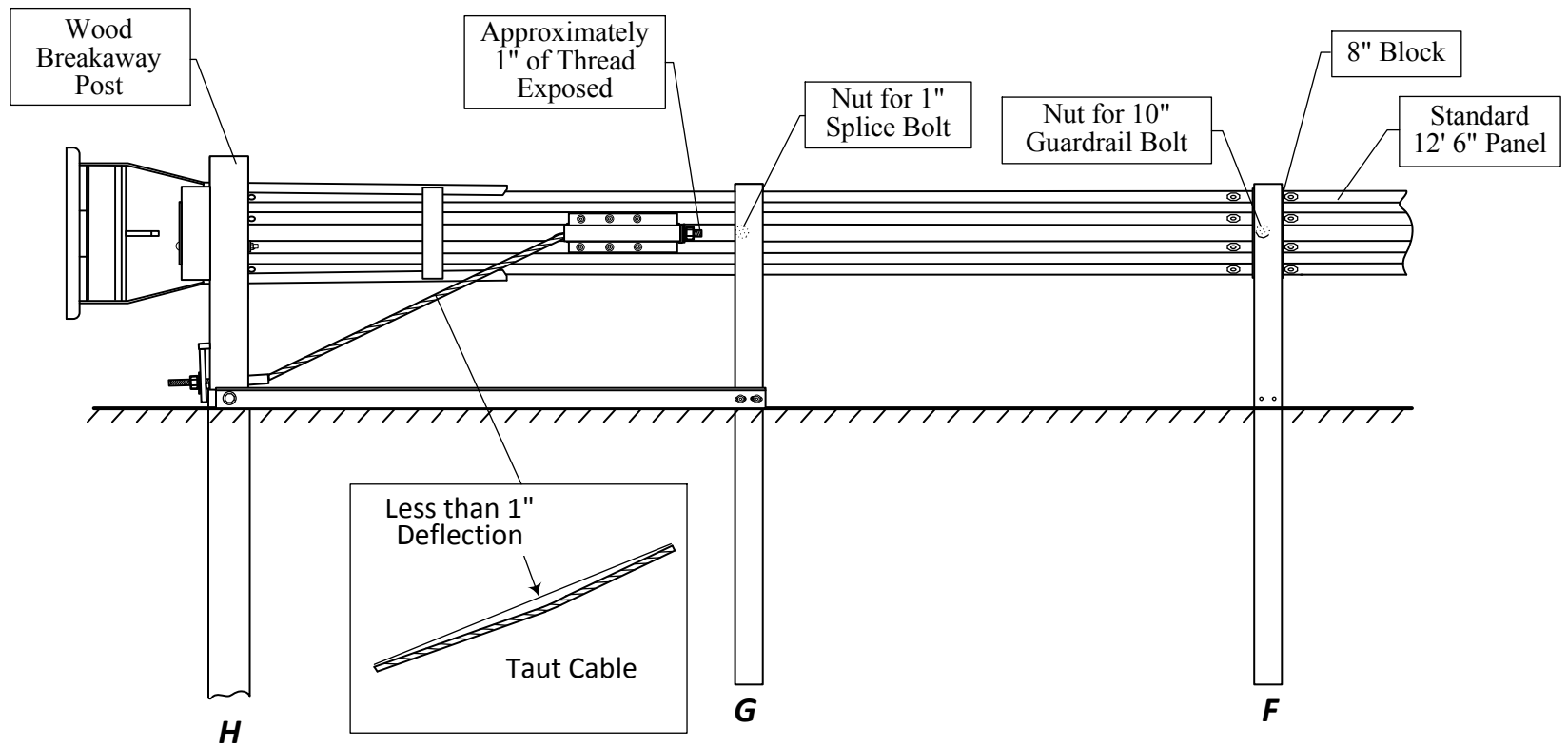

**[RIGHT SIDE] Xc. INSTALLATION OF CABLE ANCHOR**

**SPIG Industry, LLC**  
 PO Box 2617  
 Abingdon, VA 24212

SHEET NO.

DATE:

R 19 of 20

4/2/20

6. Insert 3" washered lag screws into the two holes of the Bearing Plate and screw 3" washered lag screws into Wood Breakaway Post.

**H** - 6"X8"X6' Soil Tube

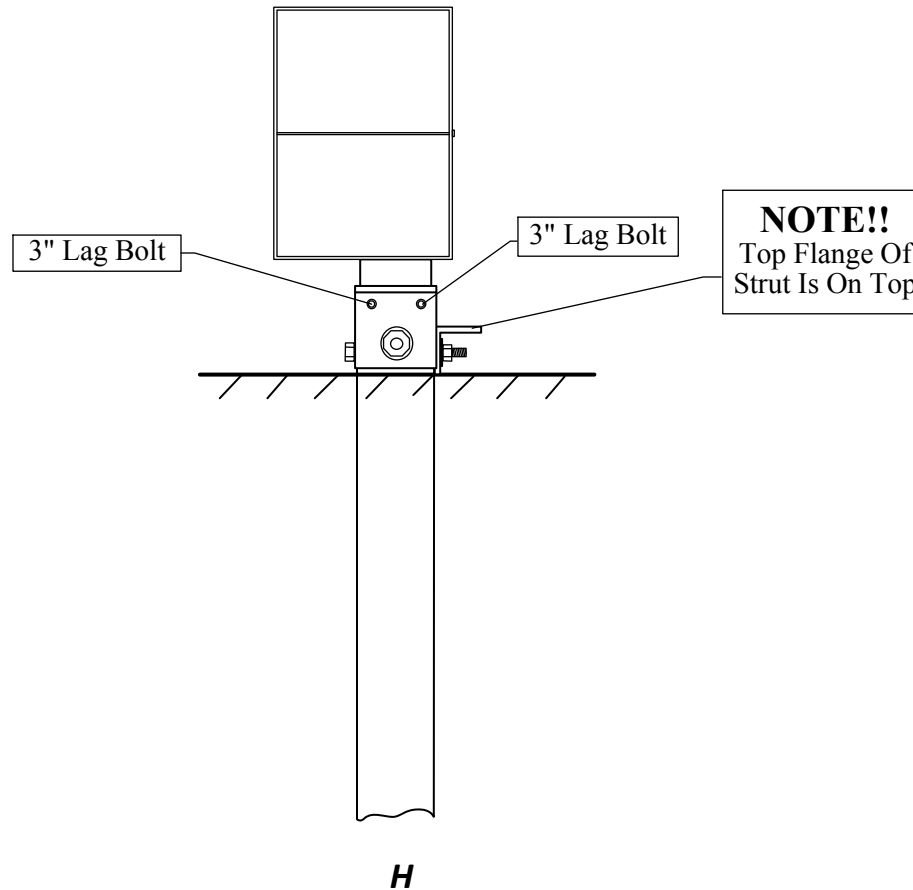

**[RIGHT SIDE] Xd. INSTALLATION OF CABLE ANCHOR**

**SPIG Industry, LLC**

PO Box 2617  
Abingdon, VA 24212

SHEET NO.

R 20 of 20

DATE:

4/2/20