

Section B - B

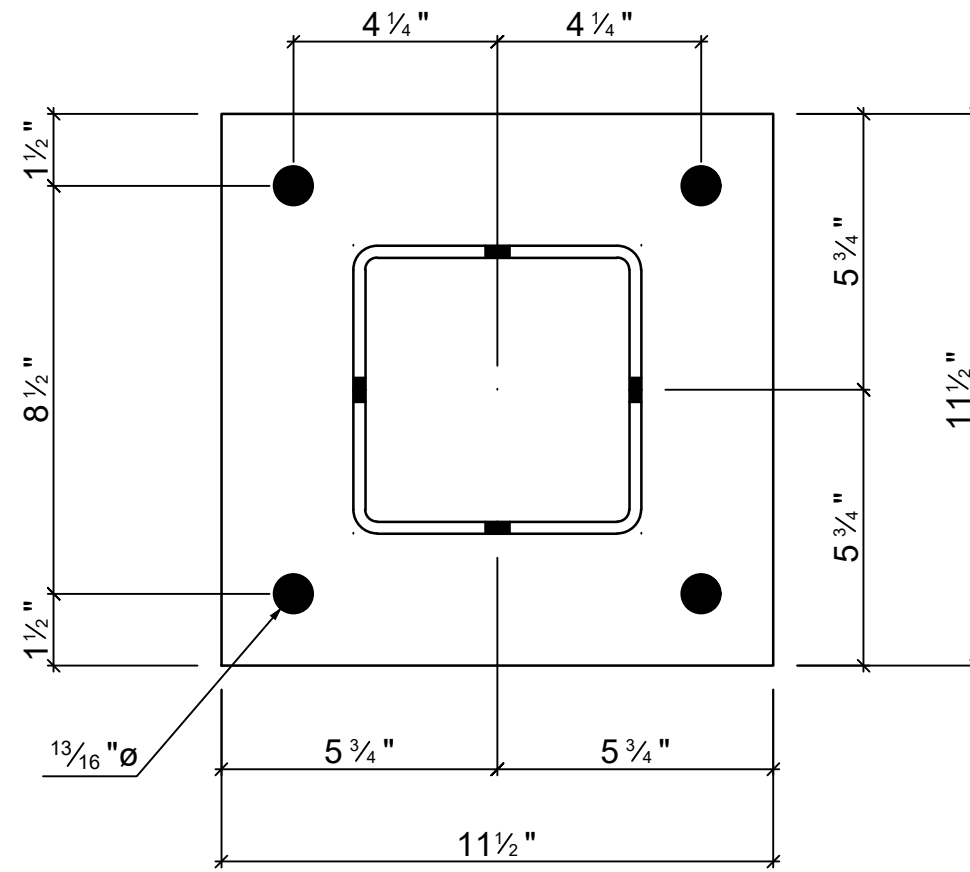
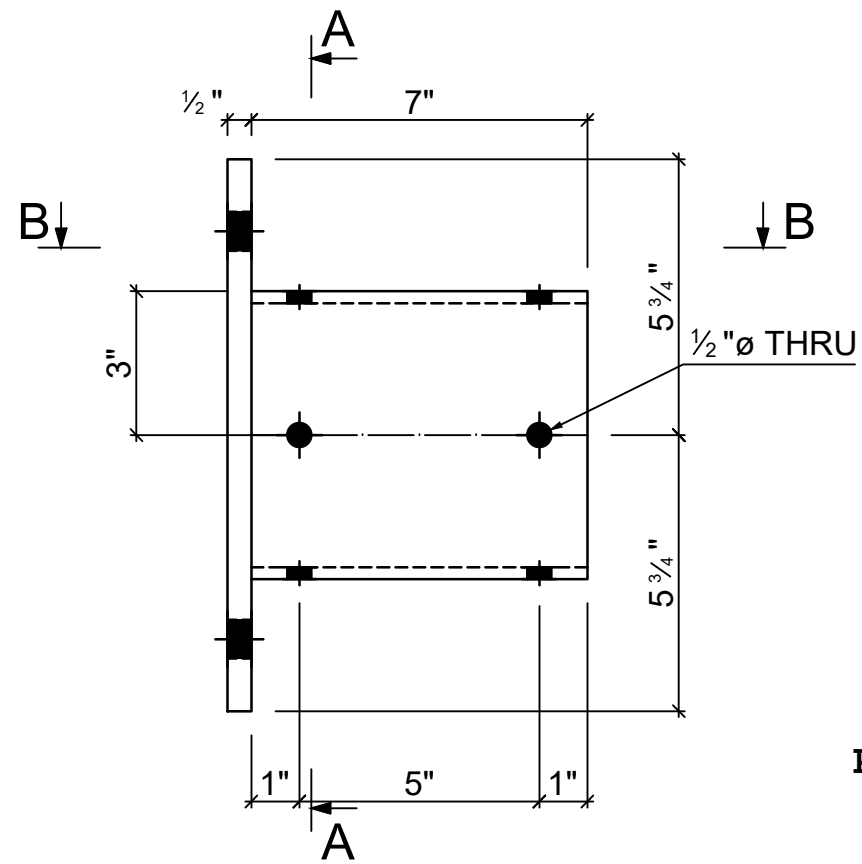

Section A - A

2 - **B1** HSS6X6X1/4
Powder Coated Black

Mark	Quantity	Description	Length	Grade	Part weight	Total weight
B1	2					
B1	2	HSS6X6X1/4	0'-7"	A500 GR.C	11.10	22.19
p102	2	PL 1/2"x11-1/2"x0'-11 1/2"	0'-11 1/2"	A36	18.75	37.51
	4				29.85	59.70
	4			TOTAL:		59.70

Quantity	Description	Length

REV.	Date	BY	Description

Project :		Project No. :	
Detailer :		Checker:	Client :
Status :		Comment:	
		Holes : 13/16"Ø u/n	Drawing No. : B1
		Weld : E70XXELECT	
		Coating : None	Phase :
		Date : 6/6/2023	



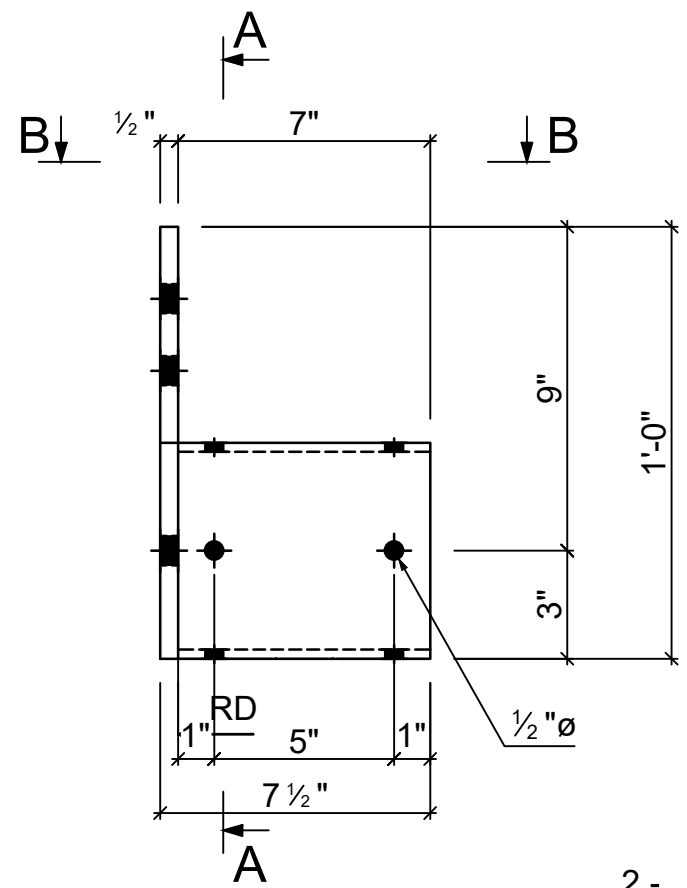

2 - **B2** HSS6X6X1/4
 Powder Coated Black

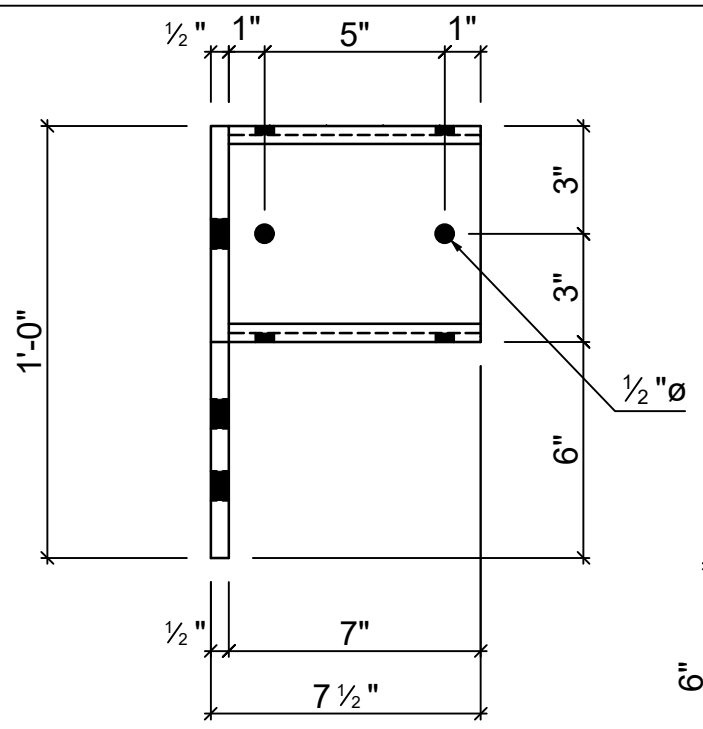

Section B - B

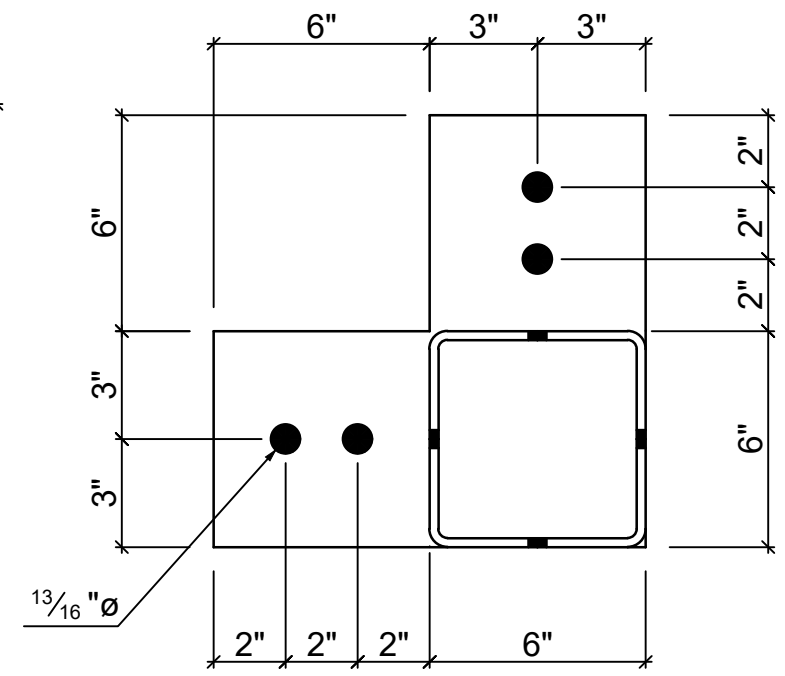

Section A - A

Mark	Quantity	Description	Length	Grade	Part weight	Total weight
B2	2					
B2	2	HSS6X6X1/4	0'-7"	A500 GR.C	11.10	22.19
p103	2	PL 1/2"x12"x1'-0"	1'-0"	A36	17.87	35.73
	4				28.96	57.92
	4			TOTAL:		57.92

Quantity	Description	Length

REV.	Date	BY	Description

Project :
 Project No. :

Detailer : Checker: Client :
 Status : Comment:

Holes : 13/16"Ø u/n Drawing No. :
 Weld : E70XXELECT **B2**

Coating : None Phase :
 Date : 6/6/2023