

1	2	3	4	5	6	7	8	9	10	11	12	13	14	15	16
SYSTEM				COMPONENT	PAGE LOC	COMPONENT	PAGE LOC	COMPONENT	PAGE LOC	COMPONENT	PAGE LOC				
SYSTEM				ALTERNATOR		LAMP		REGULATOR		SWITCH					
AIRCONDITIONER AND/OR HEATER.....8				40 AMP.....2 A1		CONTINUED....		CONTINUED...		CONTINUED...					
CHARGE, START, RUN.....2				60 AMP.....2 B3		DOME/MAP SWITCH.....9 D9		INSTRUMENT CLUSTER VOLTAGE.....3 C5		POWER WINDOW.....6 B15					
ENGINE COMPARTMENT LAMP.....10				70 AMP.....2 B4		DUAL BRAKE WARNING INDICATOR.....3 B3		EXH GAS RECIRC SOL VAC VALVE.....4 C7		R.H. POWER DOOR LOCK.....6 D14					
EXTERIOR LIGHTING.....5				AMMETER.....3 C4		ENGINE COMPARTMENT.....10 D7		STARTER MOTOR.....1 B4		REAR WINDOW WASHER.....11 C10					
HEATED BACKLITE.....6				AMPLIFIER		GLOVE BOX SWITCH.....9 C14		STARTER MOTOR.....2 B6		REAR HATCH COURTESY LAMP.....9 C13					
HORN WITH SPEED CONTROL.....11				SPEED CONTROL.....11 C5		HI BEAM INDICATOR.....5 F4				SEAT BELT BUCKLE.....3 D14					
ILLUMINATION LAMPS.....8				ARMATURE		I/P ASH TRAY ILLUMINATION.....8 E2				SEAT BELT WARNING INDICATOR.....3 B13					
IMMERSION HEATER.....10				LUGGAGE COMP DOOR LATCH.....9 E16		L.H. BACKUP.....6 E2				SEAT BELT WARNING INDICATOR.....9 U5					
POWER DISTRIBUTION.....1				BACKLITE		L.H. FRONT SIDE MARKER.....5 D9				SPEED CONTROL.....11 D2					
POWER DOOR LOCKS.....6				HEATED.....6 E9		L.H. HI BEAM HEAD.....5 D10				STOPLAMP.....11 B5					
POWER WINDOWS.....6				BATTERY		L.H. LICENSE.....6 E6				TURN AND EMERGENCY SIGNAL.....5 C5					
PROTECTION AND CONVENIENCE.....9				12 VOLT.....1 C4		L.H. LO BEAM HEAD.....5 D11				W/S/W WASHER.....11 B11					
RADIO.....7				12 VOLT.....2 B4		L.H. FRONT PARK & T/S.....5 D11				W/S/W WASHER.....11 B14					
WINDSHIELD WIPER/WASHER.....11				CAPACITOR		L.H. STOP AND PARK.....6 E5				A/C CONTROL.....8 D12					
				RADIO IGNITION INTERFERENCE.....2 F3		L.H. TURN INDICATOR.....5 F5				TACHOMETER.....3 C16					
				CHOKER		LUGGAGE COMPARTMENT.....9 E13									
				ELECTRIC.....2 D3		PRNDL ILLUMINATION (FLOOR).....8 C1									
				ELECTRIC.....2 B15		R.H. BACKUP.....6 E3									
				RADIO RECEIVER SUPPRESSION.....3 B5		R.H. FRONT SIDE MARKER.....5 D16									
				CLOCK.....9 C15		R.H. HI BEAM HEAD.....5 D15									
				COIL		R.H. LICENSE.....6 E6									
				IGNITION.....2 D8		R.H. LO BEAM HEAD.....5 D14									
				CONTROL		R.H. FRONT PARK & T/S.....5 D13									
				AM RADIO RR SPEAKER VOLUME.....7 C5		R.H. STOP AND PARK.....6 E7									
				BACK WINDOW HEAT.....6 B10		R.H. TURN INDICATOR.....5 F5									
				DISTRIBUTOR		SEAT BELTS WARNING INDICATOR.....3 D13									
				2.3 LITER BREAKERLESS.....2 D5		STEREO INDICATOR.....7 A10									
				2.8 LITER BREAKERLESS.....2 F5		LIGHTER									
				8 CYL 302 BREAKERLESS.....2 E5		CIGAR.....10 D4									
				FLASHER		CIGAR.....10 D5									
				EMERGENCY WARNING.....5 B7		MODULATOR									
				TURN SIGNAL.....5 B6		BREAKERLESS IGNITION.....2 D10									
				GAUGE		MOTOR									
				FUEL.....3 B10		A/C BLOWER.....8 B12									
				WATER TEMP.....3 B2		HEATER BLOWER.....8 C10									
				GOVERNOR		L.H. FRONT DOOR POWER WINDOW.....6 F15									
				W/S WIPER.....11 C14		R.H. FRONT DOOR POWER WINDOW.....6 F16									
				HEATER		STARTER.....2 B6									
				ENGINE BLOCK.....10 D1		W/S WASHER PUMP.....11 E9									
				HORN		W/S WASHER PUMP.....11 F14									
				HIGH PITCH.....5 E2		W/S WIPER.....11 E10									
				LAMP		W/S WIPER.....11 F12									
				A/C & HEATER CONTROLS ILLUM.....8 C4		PANEL									
				CLUSTER ILLUMINATION.....4 C9		FUSE.....1 B3									
				CLUSTER ILLUMINATION (S).....4 C11		RECEIVER									
				CLUSTER ILLUMINATION (S).....8 C4		AM RADIO.....7 B2									
				DOME.....9 D10		AM RADIO.....8 D5									
						AM/FM MONAURAL RADIO.....7 B7									
						AM/FM/MPX RADIO.....7 B3									
						AM/FM/MPX RADIO.....8 D6									
						STEREO TAPE/ AM/FM/MPX RADIO.....7 A12									
						STEREO TAPE/ AM/FM/MPX RADIO.....8 D7									
						REGULATOR									
						ALTERNATOR.....2 E1									

BULB CHART

BULB CHART

LAMP DESCRIPTION	TRADE NUMBER	LAMP DESCRIPTION	TRADE NUMBER
A/C & HEATER CONTROLS ILLUM.....161		STEREO INDICATOR.....1892	
CLUSTER ILLUMINATION.....194		AM RADIO.....1893	
DOME.....906		AM/FM MONAURAL RADIO.....1893	
DOME/MAP SWITCH.....212-2		AM/FM/MPX RADIO.....1892	
DOME/MAP SWITCH.....906 1816		AM/FM/MPX RADIO.....1893	
DUAL BRAKE WARNING INDICATOR.....194		STEREO TAPE/ AM/FM/MPX RADIO.....37	
ENGINE COMPARTMENT.....89			
GLOVE BOX SWITCH.....1816			
HI BEAM INDICATOR.....194			
I/P ASH TRAY ILLUMINATION.....1892			
L.H. BACKUP.....1156			
L.H. FRONT SIDE MARKER.....194			
L.H. HI BEAM HEAD.....H-4651			
L.H. LICENSE.....168			
L.H. LO BEAM HEAD.....H-4656			
L.H. FRONT PARK & T/S.....1157			
L.H. STOP AND PARK.....1157			
L.H. TURN INDICATOR.....194			
LUGGAGE COMPARTMENT.....89			
PRNDL ILLUMINATION (FLOOR).....1893			
R.H. BACKUP.....1156			
R.H. FRONT SIDE MARKER.....194			
R.H. HI BEAM HEAD.....H-4651			
R.H. LICENSE.....168			
R.H. LO BEAM HEAD.....H-4656			
R.H. FRONT PARK & T/S.....1157			
R.H. STOP AND PARK.....1157			
R.H. TURN INDICATOR.....194			
SEAT BELTS WARNING INDICATOR.....194			

**GROUND CODES**

**SPLICE CODES**

ELECTRICAL SYSTEMS 1982 MUSTANG/CAPRI  
EFFECTIVE P.C.R. INDEX-SYSTEM AND COMPONENT  
SUPERSEDES  
DATE 6-30-81

BEPE ELECT INST MAN PAGE E22-900-INDEX  
SERVICE AND TRAINING MAN PAGE INDEX

**WIRING COLOR KEY  
(PRIMARY COLORS)**

BLACK	BK
BROWN	BR
TAN	T
RED	R
PINK	PK
ORANGE	O
YELLOW	Y
DARK GREEN	DG
LIGHT GREEN	LG
DARK BLUE	DB
LIGHT BLUE	LB
PURPLE	P
GRAY	GY
WHITE	W
HASH	(H)
DOT	(D)

The presence of a tracer on the wire is indicated by a secondary color followed by an 'H' for Hash or a 'D' for Dot. A stripe is understood if no letter follows.

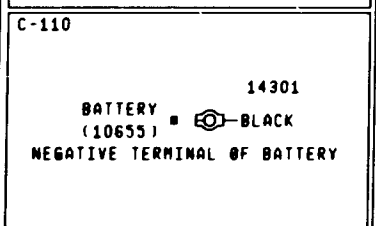
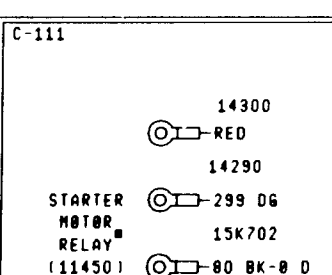
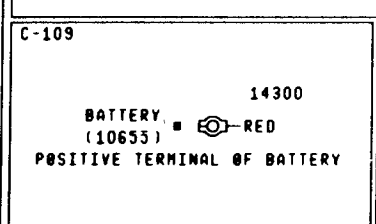
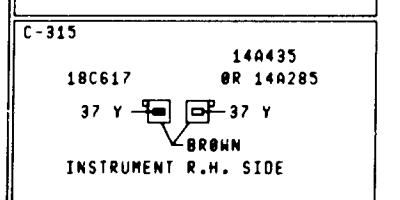
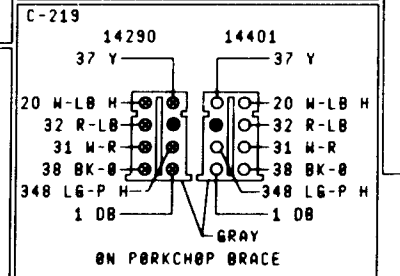
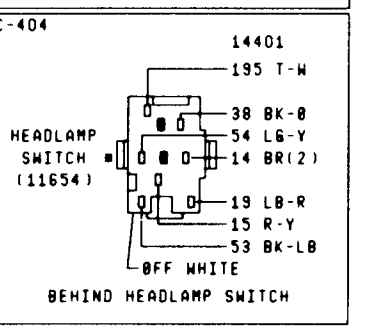
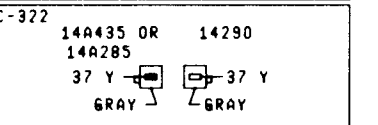
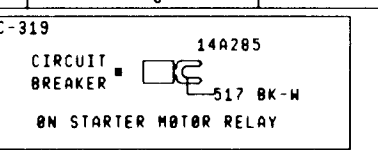
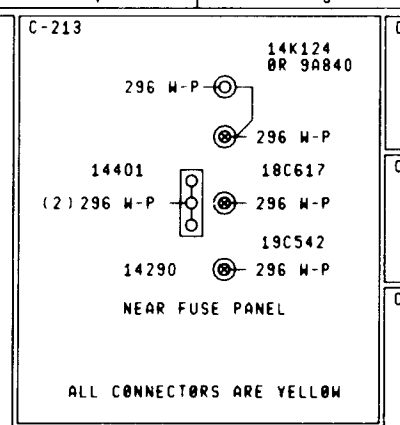
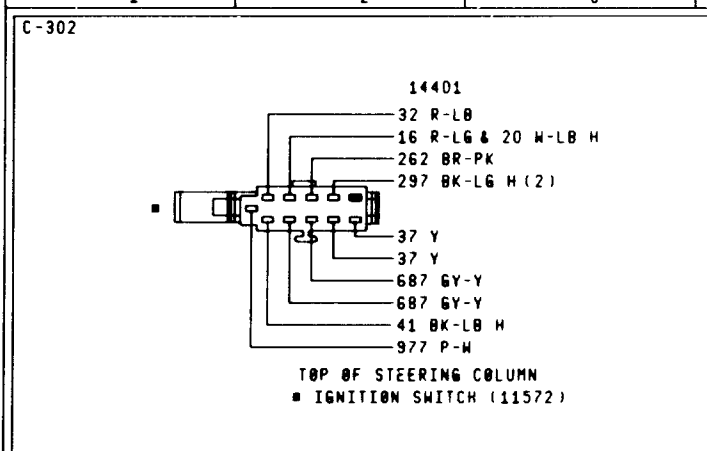
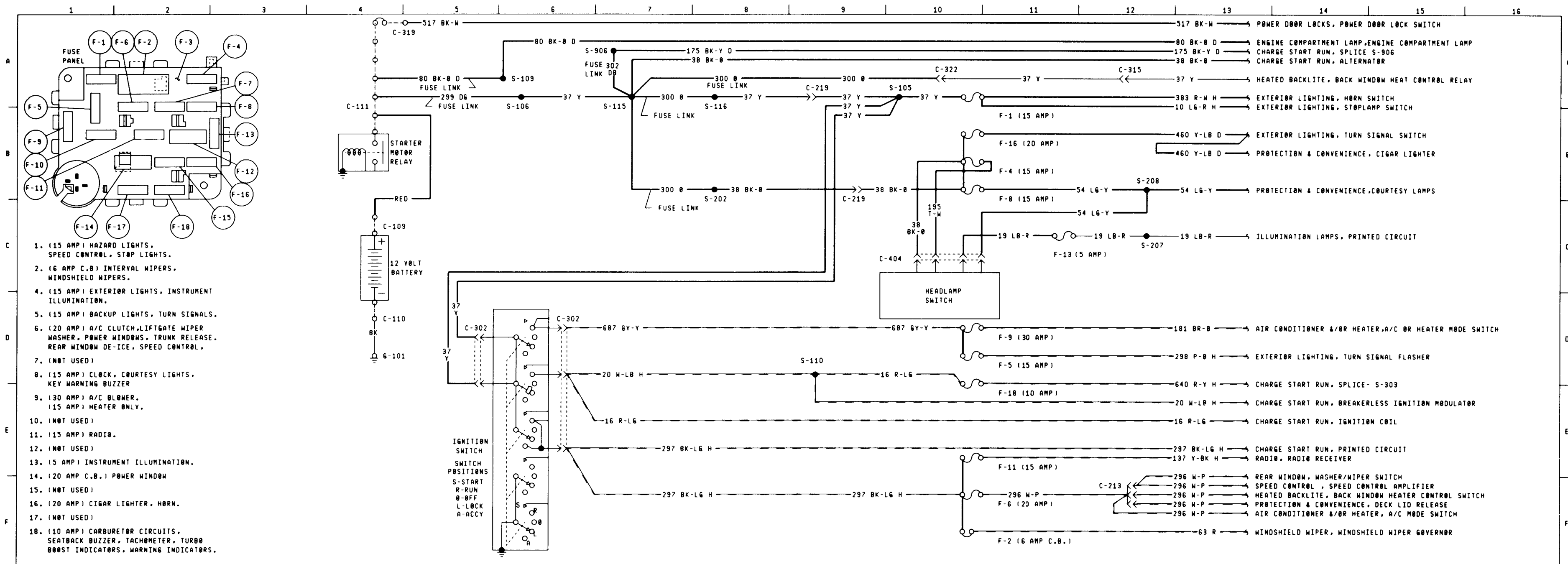

**WIRING COLOR KEY (PRIMARY COLORS)**

BLACK	BK
BROWN	BR
TAN	T
RED	R
PINK	PK
ORANGE	O
YELLOW	Y
DARK GREEN	DG
LIGHT GREEN	LG
DARK BLUE	DB
LIGHT BLUE	LB
PURPLE	P
GRAY	GY
WHITE	W
HASH	(H)
DOT	(D)

The presence of a tracer on the wire is indicated by a secondary color followed by an "H" for Hash or a "D" for Dot. A stripe is understood if no letter follows.

GROUND CODES	
G-101	ON DASH BEHIND BATTERY

SPLICE CODES	
S-105	IN 14401, NEAR T/O TO WINDSHIELD WIPER SWITCH
S-106	IN 14290, NEAR T/O TO ALTERNATOR REGULATOR
S-109	IN 15K702, NEAR T/O TO STARTER MOTOR RELAY
S-110	IN 14401, NEAR T/O TO W/S/WIPER SWITCH
S-115	IN 14290, NEAR T/O TO ALTERNATOR REGULATOR
S-116	IN 14290, NEAR T/O TO STARTER RELAY
S-202	IN 14290, NEAR T/O TO STARTER MOTOR RELAY
S-207	IN 14401 NEAR RADIO RECEIVER
S-208	IN 14401 NEAR FUSE PANEL
S-906	IN 14A303, UNDER SHIELD NEAR SEAT

ELECTRICAL SYSTEMS 1982 MUSTANG/CAPRI  
POWER DISTRIBUTION

EFFECTIVE P.C.R. SUPERSEDES DATE 6-30-81

BEPE ELECT INST MAN PAGE E22-900-1  
SERVICE AND TRAINING MAN PAGE 1

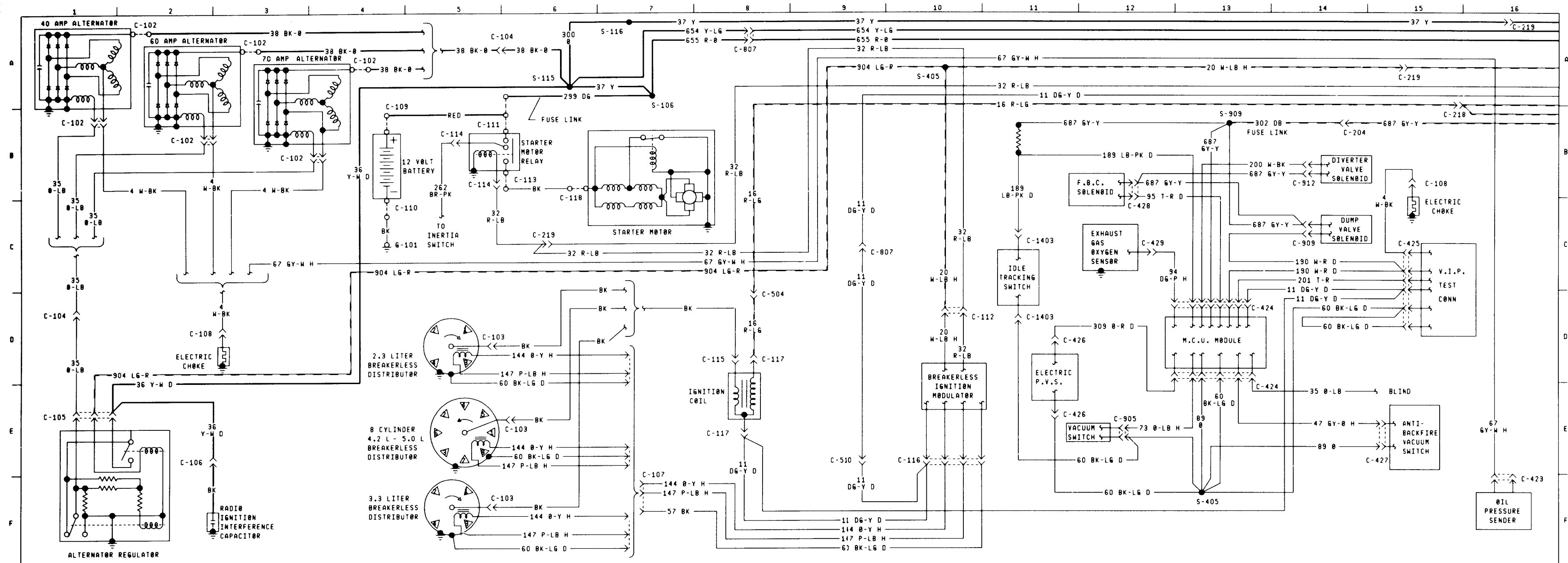

<b>C-118</b> STARTER MOTOR (11001) R.H. REAR OF ENGINE	<b>C-504</b> 14A227 13A756 53 BK-LB 53 BK-LB 54 LG-Y 54 LG-Y GRAY
<b>C-219</b> 14290 14401 37 Y 37 Y 20 W-LB H 20 W-LB H 32 R-LB H 32 R-LB H 31 W-R 31 W-R 38 BK-Ø 38 BK-Ø 348 LG-P H 348 LG-P H 1 DB 1 DB GRAY ON PARKING BRACE	<b>C-807</b> 14290 14401 11 DG-Y D(2) 11 DG-Y D 39 R-W 39 R-W 655 R-Ø 655 R-Ø 654 Y-LG 654 Y-LG 687 GY-Y 687 GY-Y 640 R-Y H 640 R-Y H BROWN L.H. SIDE OF INSTRUMENT PANEL
<b>C-423</b> 14289 67 GY-M H 68 Ø-BK OIL PRESSURE SENDER	<b>C-905</b> 14290 73 Ø-LB H 12157 BK GRAY PART OF THE VACUUM SWITCH
<b>C-424</b> 9E724 95 T-R D 200 W-BK 200 W-BK 190 W-R D 190 W-R D 11 DG-Y D 687 GY-Y 73 Ø-LB H 47 GY-Ø H 189 LB-PK D 358 LG-BK 309 Ø-R D 201 T-R 94 DG-P H 89 Ø 60 BK-LG D TO M.C.U. MODULE ENGINE COMP NEAR ALTERNATOR	<b>C-909</b> 9E724 190 W-R D 687 GY-Y(2) PART OF DUMP VALVE SOLENOID
<b>C-1403</b> 14289 189 LB-PK D 60 BK-LG D IDLE TRACKING SWITCH NEAR CARBURETOR	<b>C-912</b> 14290 200 W-BK 14290 687 GY-Y PART OF DIVERTER VALVE SOLENOID
<b>C-425</b> 9E724 11 DG-Y D(2) 60 BK-LG D(2) 60 BK-LG D 4 W-BK 201 T-R 190 W-R D(2) V.I.P. TEST CONNECTOR ENGINE COMP NEAR ALTERNATOR	<b>C-117</b> 14289 ØR 12060 16 R-LG 11 DG-Y D(2) BLUE R.H. SIDE OF DASH PANEL
<b>C-426</b> 9E724 60 BK-LG D 309 Ø-R D NATURAL ENGINE COMP NEAR ALTERNATOR	<b>C-427</b> 9E724 47 GY-Ø H 60 BK-LG D ANTI-BACKFIRE VACUUM SWITCH ENGINE COMP NEAR DISTRIBUTOR
<b>C-428</b> 9E724 95 T-R D 95 T-R D 687 GY-Y(2) BROWN ENGINE COMP NEAR R.H. SHOCK	<b>C-429</b> 9E724 94 DG-P H EXHAUST GAS OXYGEN SENSOR OFF WHITE ENGINE COMP NEAR CARB R.H. SIDE

**WIRING COLOR KEY (PRIMARY COLORS)**

BLACK	BK
BROWN	BR
TAN	T
RED	R
PINK	PK
ORANGE	O
YELLOW	Y
DARK GREEN	DG
LIGHT GREEN	LG
DARK BLUE	DB
LIGHT BLUE	LB
PURPLE	P
GRAY	GY
WHITE	W
HASH	(H)
DOT	(D)

The presence of a tracer on the wire is indicated by a secondary color followed by an "H" for Hash or a "D" for Dot. A stripe is understood if no letter follows.

<b>C-107</b> 12127 9E724 ØR 14289 144 Ø-Y H 144 Ø-Y H 60 BK-LG D 57 BK 147 P-LB H 147 P-LB H BROWN ENGINE COMPARTMENT NEAR DISTRIBUTOR	<b>C-204</b> 14290 9E724 ØR 14289 14289 687 GY-Y 302 DB 11 DG-Y D 11 DG-Y D(2) 347 BK-Y H(2) 347 BK-Y H 640 R-Y H 640 R-Y H 31 W-R 31 W-R 39 R-W 39 R-W 16 R-LG 16 R-LG GRAY ENGINE COMPARTMENT NEAR COIL	<b>C-510</b> 14290 14289 354 LG-Y 354 LG-Y 189 LB-PK D 189 LB-PK D 57 BK 57 BK 11 DG-Y D 11 DG-Y D(2) 16 R-LG 16 R-LG 45 Y-R 45 Y-R 459 Ø-LG 459 Ø-LG 31 W-R 31 W-R 39 R-W 39 R-W GRAY ENGINE COMPARTMENT NEAR COIL TURBO ONLY	<b>C-105</b> 14290 35 Ø-LB 904 LG-R 12136 Y-W D BLUE R.H. FRONT FENDER APRON	<b>C-111</b> 14300 RED 14290 STARTER MOTOR RELAY (11450) 80 BK-Ø D 37 Y R.H. FRONT FENDER APRON	<b>C-115</b> 12127 BK 12029 IGNITION COIL R.H. SIDE OF DASH PANEL	<b>C-117</b> 14289 ØR 12060 16 R-LG 11 DG-Y D(2) BLUE R.H. SIDE OF DASH PANEL
<b>C-116</b> 12A199 14289 ØR 9E724 60 BK-LG D 57 BK 147 P-LB H 147 P-LB H 11 DG-Y D 11 DG-Y D(2) 144 Ø-Y H FOR HIGH ENERGY COIL ONLY CANADA ONLY WITH AUTO TRANS	<b>C-218</b> 14290 14401 82 PK-Y 82 PK-Y 941 BK-W 941 BK-W 16 R-LG 16 R-LG & 262 BR-PK GRAY BEHIND FUSE PANEL	<b>C-102</b> 14305 4 W-BK 35 Ø-LB ALTERNATOR (70 AMP)	<b>C-103</b> DISTRIBUTOR (12127) BK ON ENGINE	<b>C-108</b> 14305 4 W-BK CARBURETOR CHOKE CONTROL (9700) ON CARBURETOR	<b>C-109</b> 14300 RED BATTERY (10655) POSITIVE TERMINAL OF BATTERY	<b>C-110</b> 14301 BLACK BATTERY (10655) NEGATIVE TERMINAL OF BATTERY
<b>C-104</b> 14290 14305 38 BK-Ø 38 BK-Ø 35 Ø-LB 35 Ø-LB BROWN 40 & 60 AMP ENGINE COMPARTMENT	<b>C-106</b> 18801 14290 BK 36 Y-W D R. H. FRONT FENDER APRON	<b>C-112</b> 12A199 14290 32 R-LB 32 R-LB(2) 20 W-LB H 20 W-LB H ENGINE COMPARTMENT NEAR BREAKERLESS IGNITION MODULATOR	<b>C-113</b> 14431 BK STARTER MOTOR RELAY (11450) R.H. FRONT FENDER APRON	<b>C-114</b> 14290 14290 32 R-LB 32 R-LB RED STARTER MOTOR RELAY (11450) R. H. FRONT FENDER APRON	<b>GROUND CODES</b> G-101 ON DASH BEHIND BATTERY	<b>SPICE CODES</b> S-106 IN 14290, NEAR 1/8 TO ALTERNATOR REGULATOR S-115 IN 14290, NEAR 1/8 TO ALTERNATOR REGULATOR S-116 IN 14290, NEAR 1/8 TO STARTER RELAY S-405 IN 9E724 NEAR M.C.U. MODULE S-909 IN 14290, NEAR 1/8 TO W/S WIPER SWITCH
<b>EFFECTIVE P.C.R. SUPERSEDES DATE 6-30-81</b> BEPE ELECT INST MAN PAGE E2Z-900-2 SERVICE AND TRAINING MAN PAGE 2						

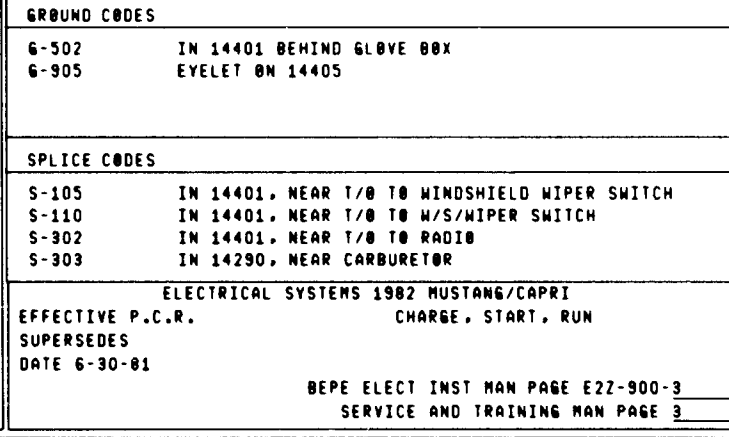
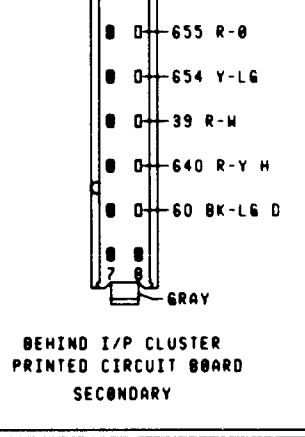
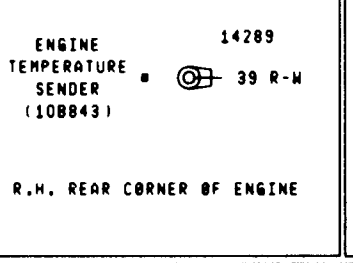
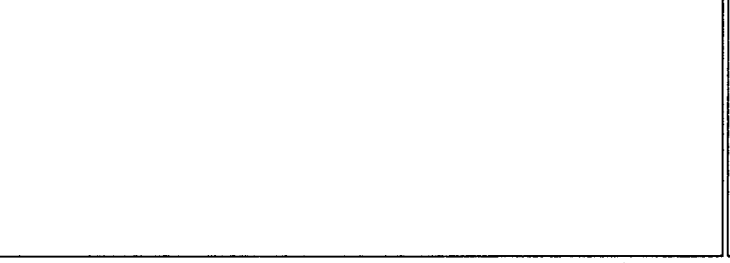
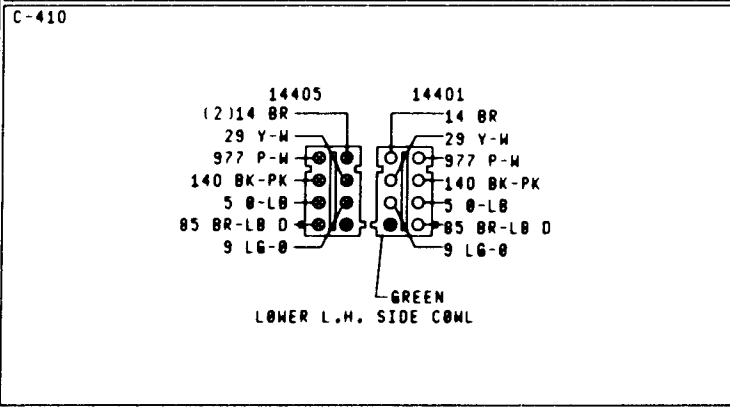
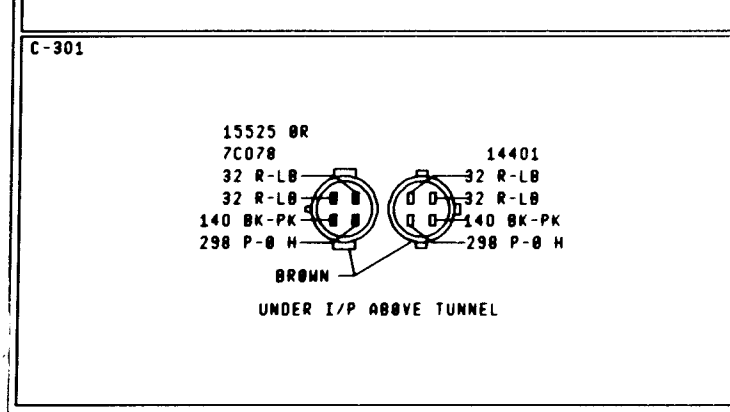
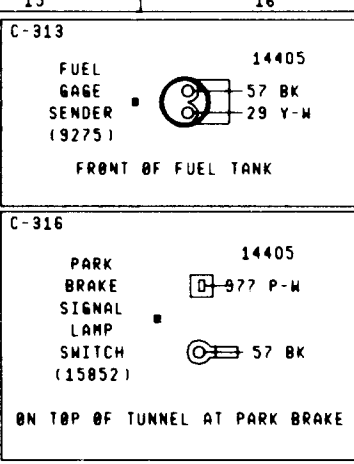
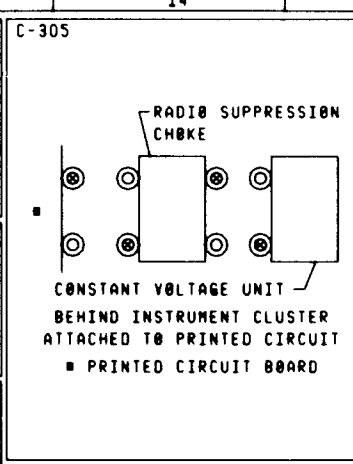
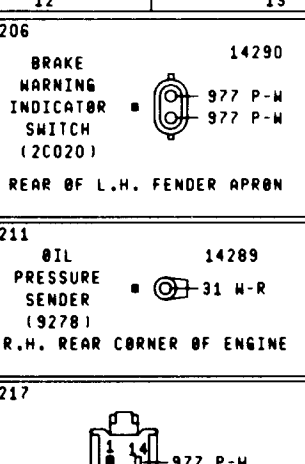
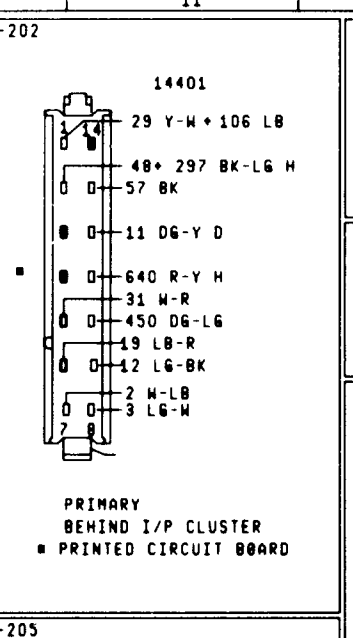
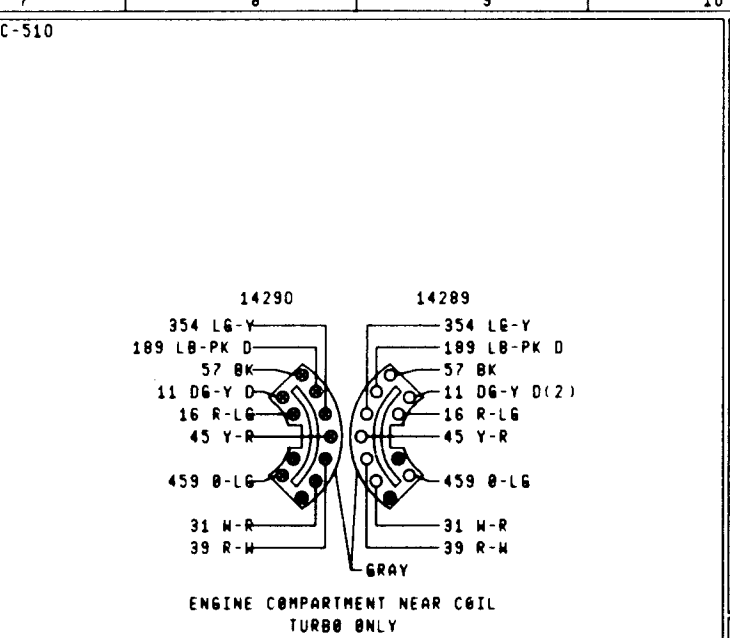
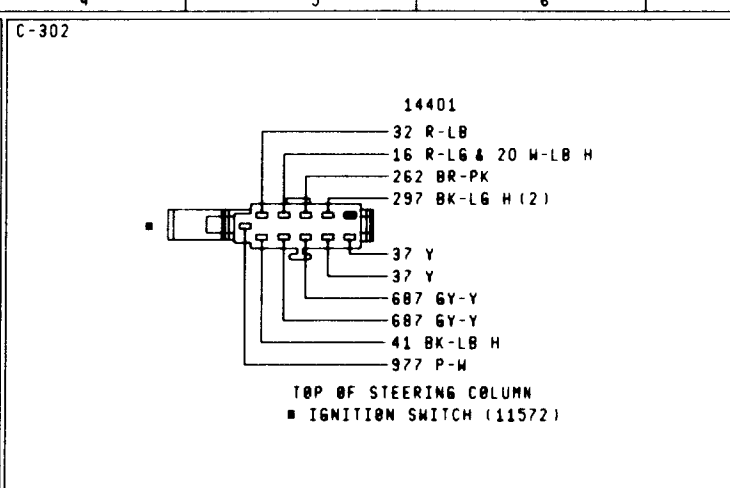
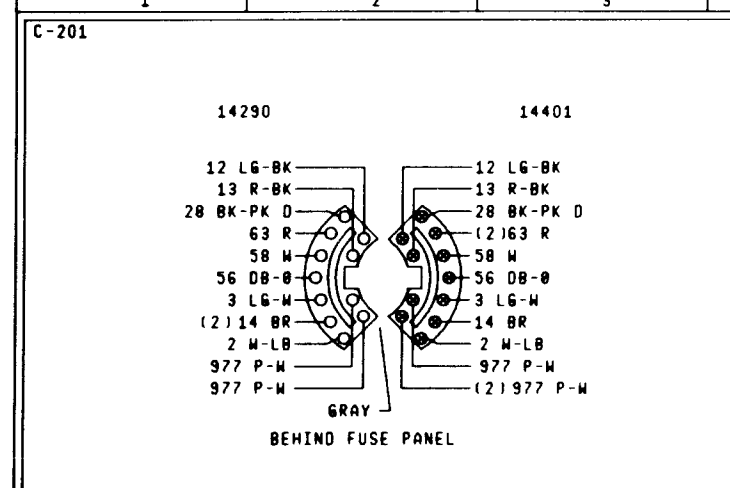
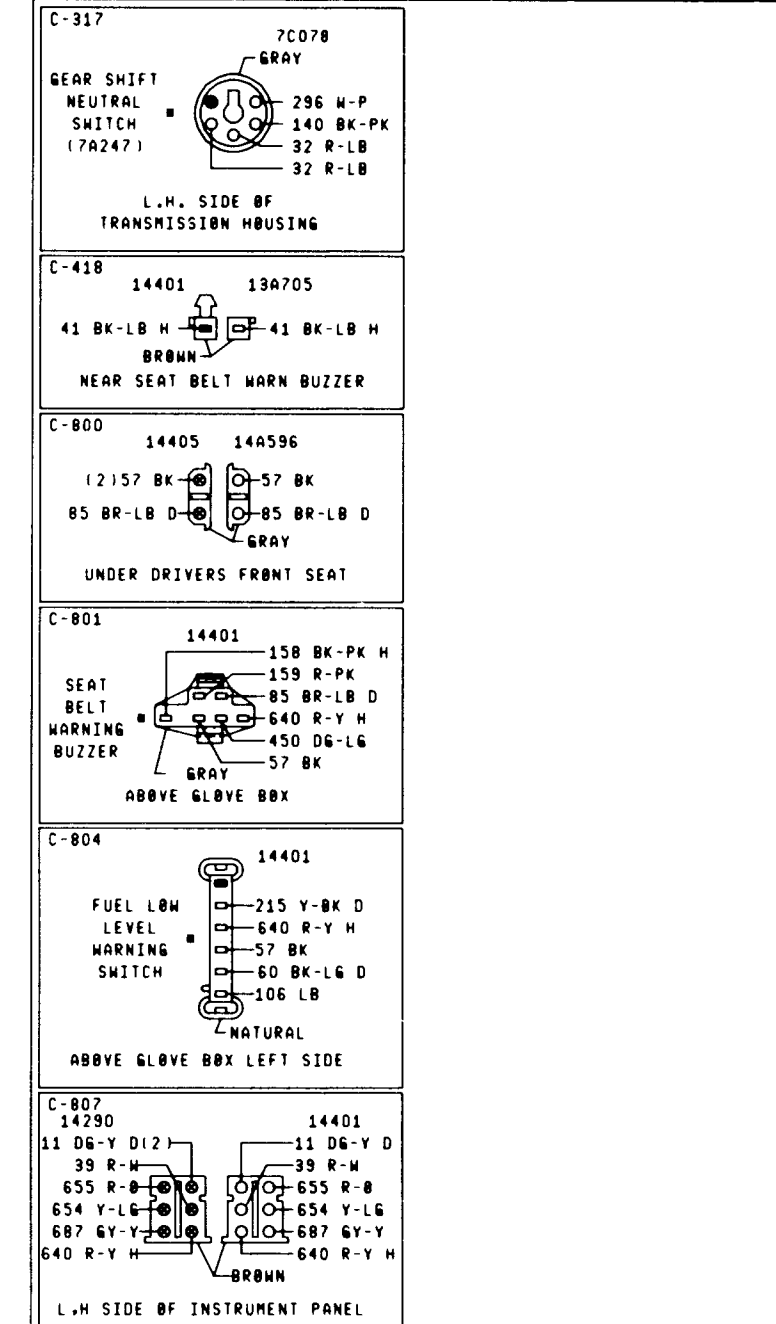
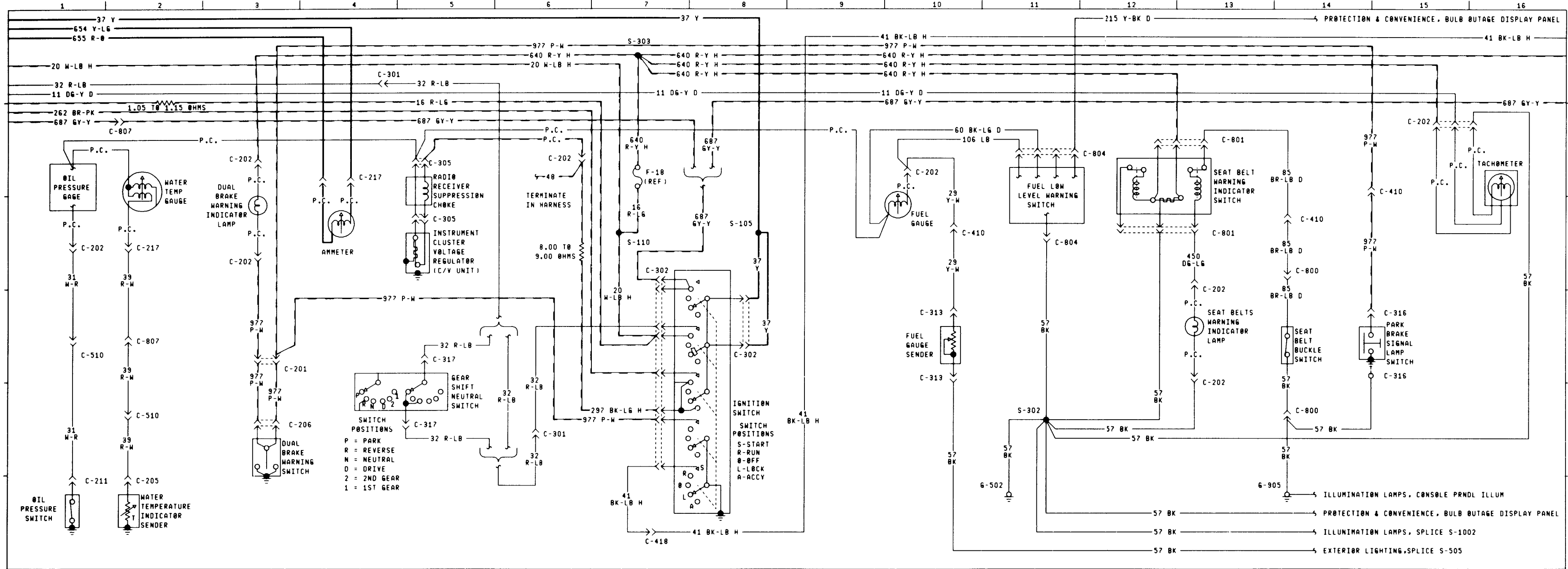

**WIRING COLOR KEY (PRIMARY COLORS)**

BLACK	BK
BROWN	BR
TAN	T
RED	R
PINK	PK
ORANGE	O
YELLOW	Y
DARK GREEN	DG
LIGHT GREEN	LG
DARK BLUE	DB
LIGHT BLUE	LB
PURPLE	P
GRAY	GY
WHITE	W
HASH	(H)
DOT	(D)

The presence of a tracer on the wire is indicated by a secondary color followed by an 'H' for Hash or a 'D' for Dot. A stripe is understood if no letter follows.

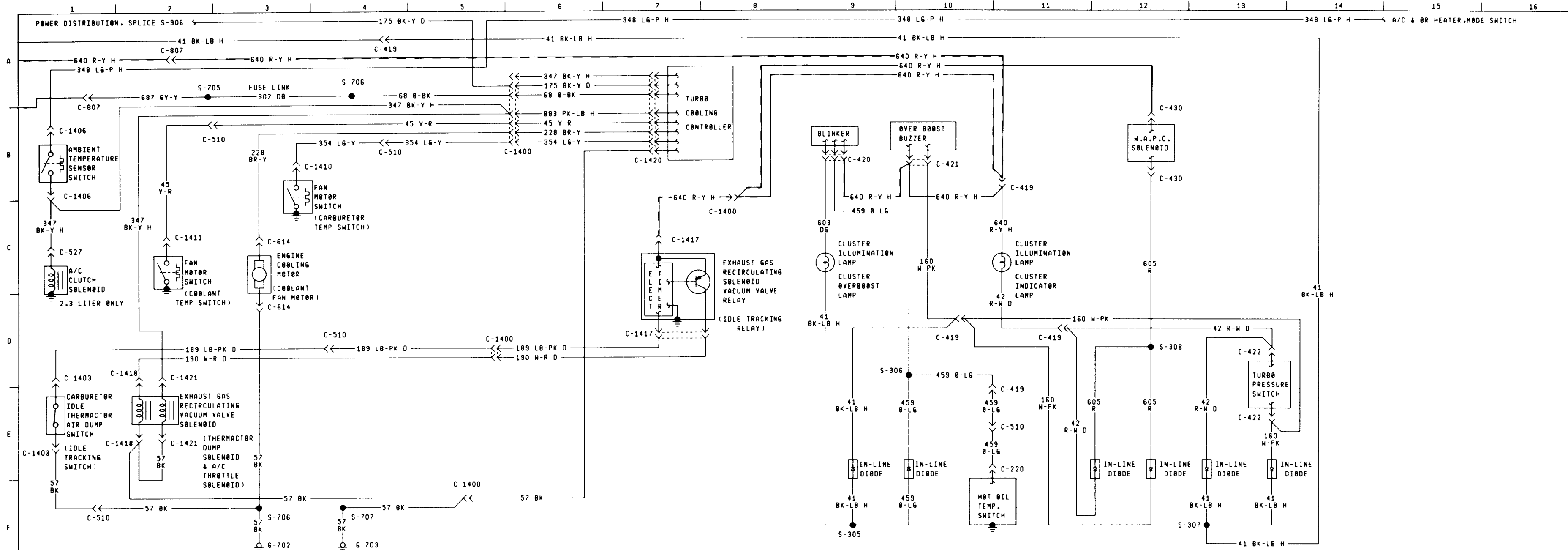

<p><b>C-419</b></p> <p>ENGINE COMP DASH PANEL</p>	<p><b>C-1400</b></p> <p>R.H. SIDE OF DASH PANEL TURBO ONLY</p>	<p><b>C-614</b></p> <p>L.H. SIDE ENGINE COMPARTMENT</p>	<p><b>C-1410</b></p> <p>NEAR CARBURETOR</p>	<p><b>C-1420</b></p> <p>ENGINE COMPARTMENT</p>
<p><b>C-510</b></p> <p>ENGINE COMPARTMENT NEAR COIL TURBO ONLY</p>	<p><b>C-220</b></p> <p>ON ENGINE</p>	<p><b>C-422</b></p> <p>TURBO PRESSURE SWITCH</p>	<p><b>C-1403</b></p> <p>NEAR CARBURETOR</p>	<p><b>C-1417</b></p> <p>STRUT NEAR CENTRE OF I/P</p>
	<p><b>C-420</b></p> <p>BLINKER</p>	<p><b>C-430</b></p> <p>ENGINE COMP R.H. SIDE</p>	<p><b>C-1406</b></p> <p>R.H. SIDE OF ENGINE COMPARTMENT</p>	<p><b>C-1418</b></p> <p>ON DASH PANEL</p>
	<p><b>C-421</b></p> <p>OVERBOOST BUZZER</p>	<p><b>C-527</b></p> <p>A/C CLUTCH SOLENOID</p>		

GROUND CODES	
G-702	IN 14290 NEAR L.H. HEADLAMP
G-703	IN 14290 NEAR R.H. HEADLAMPS

SPLICE CODES	
S-305	IN 13A705 NEAR T/Ø TO DIODE
S-306	IN 13A705 NEAR T/Ø TO DIODE
S-307	IN 14290 NEAR T/Ø TO DIODE
S-308	IN 14290 NEAR IGNITION MODULE
S-705	IN 14290 AT DASH PANEL
S-706	IN 14290 NEAR L.H. HEADLAMP
S-707	IN 14290 NEAR R.H. HEADLAMPS

ELECTRICAL SYSTEMS 1982 MUSTANG/CAPRI	
EFFECTIVE P.C.R.	CHARGE, START, RUN
SUPERSEDES	
DATE 6-30-81	

BEPE ELECT INST MAN PAGE E22-900-4  
SERVICE AND TRAINING MAN PAGE 4

**WIRING COLOR KEY (PRIMARY COLORS)**

BLACK	BK
BROWN	BR
TAN	T
RED	R
PINK	PK
ORANGE	O
YELLOW	Y
DARK GREEN	DG
LIGHT GREEN	LG
DARK BLUE	DB
LIGHT BLUE	LB
PURPLE	P
GRAY	GY
WHITE	W
HASH	(H)
DOT	(D)

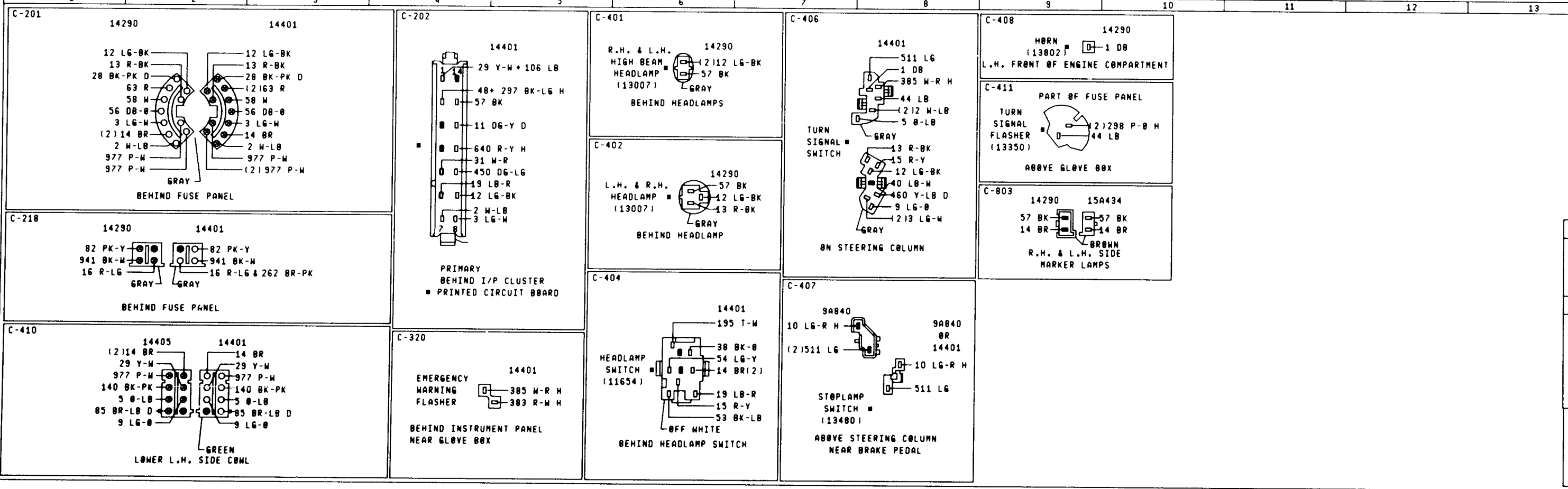
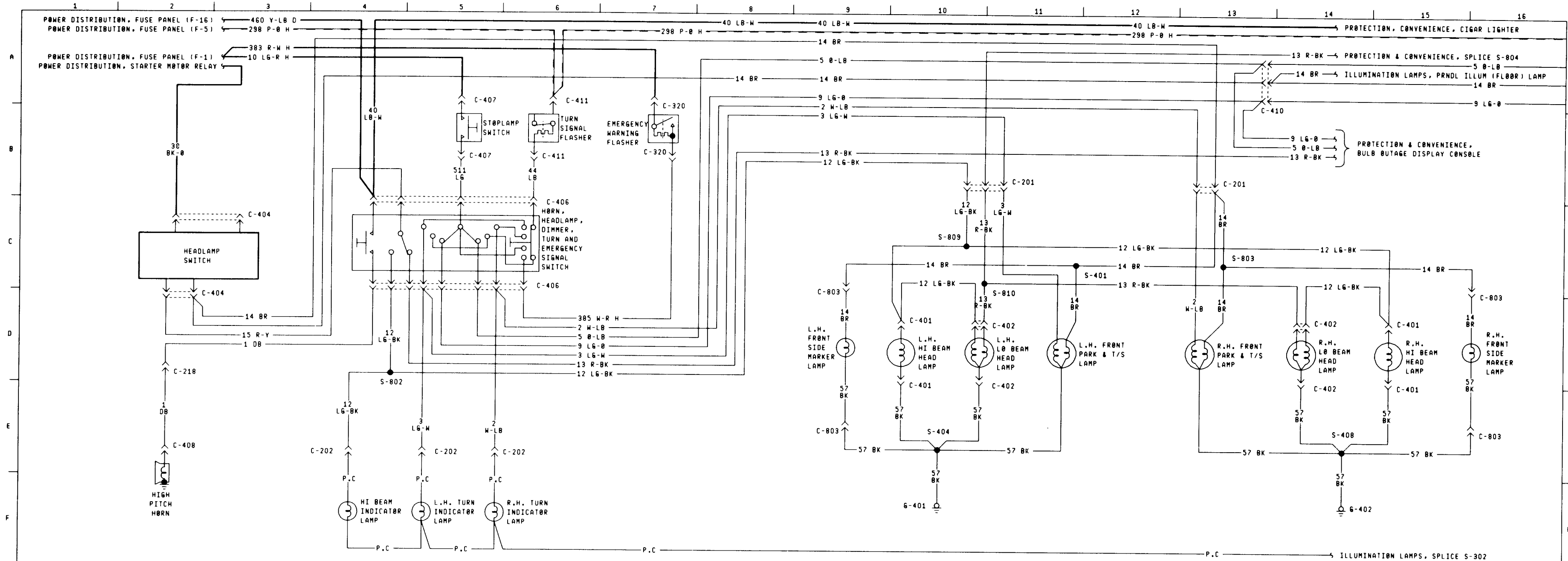

GROUND CODES	
G-401	EYELET BN 14290 NEAR L.H. HEADLAMP
G-402	EYELET BN 14398 NEAR R.H. HEADLAMP

SPLICE CODES	
S-401	IN 14290, NEAR T/O TO L.H. PARK LAMP
S-404	IN 14290, NEAR GROUND TAKEOUT
S-408	IN 14398, NEAR T/O TO R.H. FRONT SIDE MARKER LAMP
S-802	IN 14401, NEAR T/O TO PRINTED CIRCUIT
S-803	IN 14398, NEAR T/O TO R.H. HEADLAMP
S-809	IN 14290, NEAR GROUND
S-810	IN 14290, NEAR T/O W/S WIPER MOTOR

  

ELECTRICAL SYSTEMS 1982 MUSTANG/CAPRI EXTERIOR LIGHTING	
EFFECTIVE P.C.R.	SUPERSEDES
DATE 6-30-81	

**WIRING COLOR KEY (PRIMARY COLORS)**

BLACK	BK
BROWN	BR
TAN	T
RED	R
PINK	PK
ORANGE	O
YELLOW	Y
DARK GREEN	DG
LIGHT GREEN	LG
DARK BLUE	DB
LIGHT BLUE	LB
PURPLE	P
GRAY	GY
WHITE	W
HASH	(H)
DOT	(D)

The presence of a tracer on the wire is indicated by a secondary color followed by an "H" for Hash or a "D" for Dot. A stripe is understood if no letter follows.

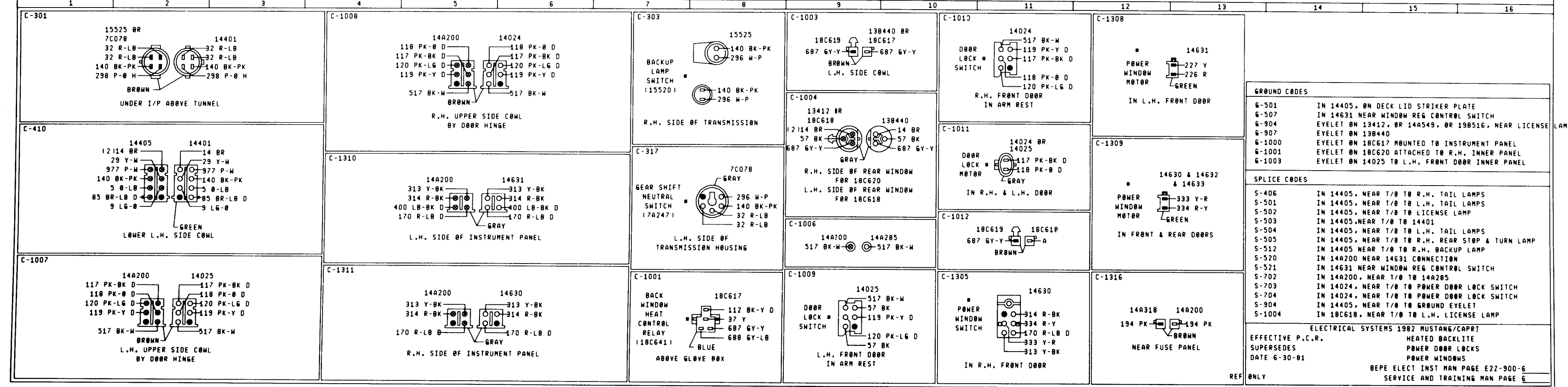
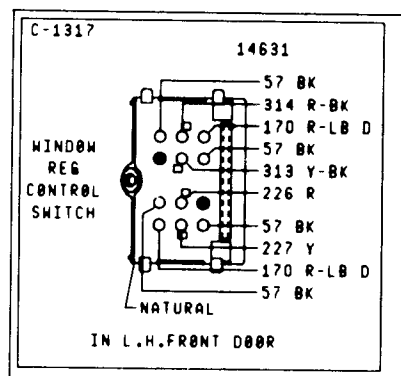
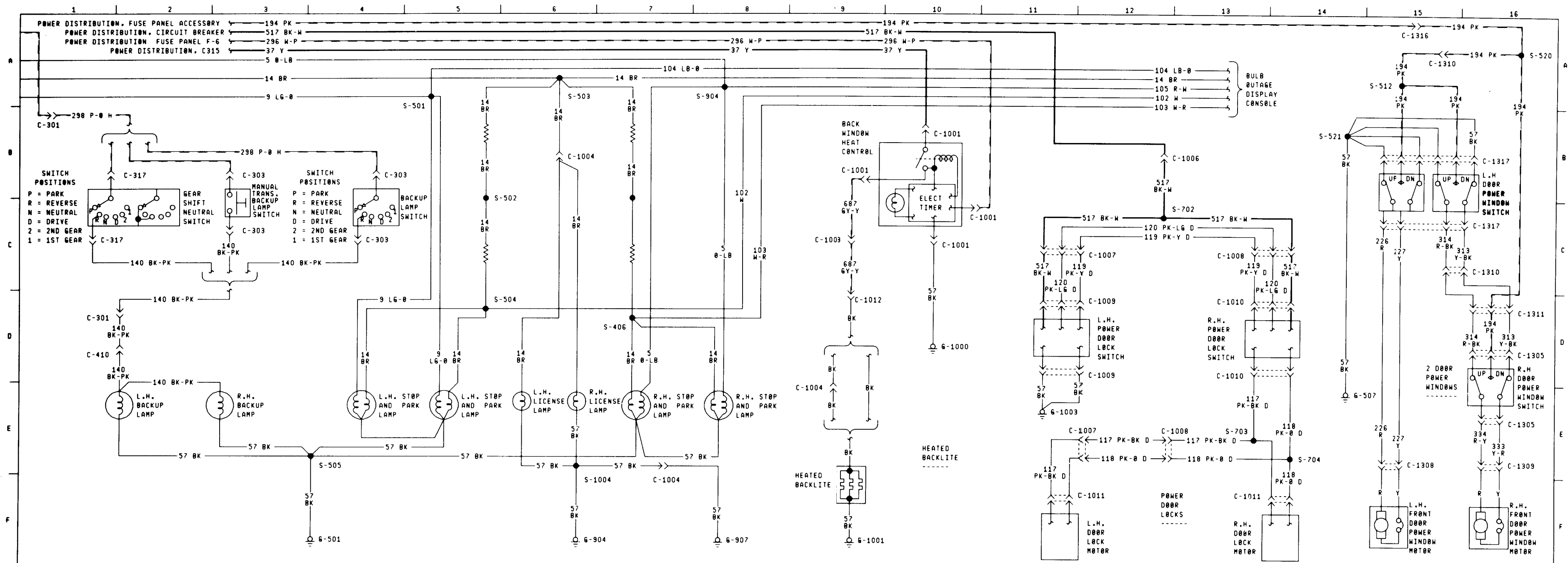

GROUND CODES	
G-501	IN 14405, ON DECK LID STRIKER PLATE
G-507	IN 14631 NEAR WINDOW REG CONTROL SWITCH
G-904	EYELET ON 13412, OR 14A549, OR 19B516, NEAR LICENSE
G-907	EYELET ON 138440
G-1000	EYELET ON 18C617 MOUNTED TO INSTRUMENT PANEL
G-1001	EYELET ON 18C620 ATTACHED TO R.H. INNER PANEL
G-1003	EYELET ON 14025 TO L.H. FRONT DOOR INNER PANEL

SPLICE CODES	
S-406	IN 14405, NEAR 1/8 TO R.H. TAIL LAMPS
S-501	IN 14405, NEAR 1/8 TO L.H. TAIL LAMPS
S-502	IN 14405, NEAR 1/8 TO LICENSE LAMP
S-503	IN 14405, NEAR 1/8 TO 14401
S-504	IN 14405, NEAR 1/8 TO L.H. TAIL LAMPS
S-505	IN 14405, NEAR 1/8 TO R.H. STOP & TURN LAMP
S-512	IN 14405 NEAR 1/8 TO R.H. BACKUP LAMP
S-520	IN 14A200 NEAR 14631 CONNECTION
S-521	IN 14631 NEAR WINDOW REG CONTROL SWITCH
S-702	IN 14A200, NEAR 1/8 TO 14A285
S-703	IN 14024, NEAR 1/8 TO POWER DOOR LOCK SWITCH
S-704	IN 14024, NEAR 1/8 TO POWER DOOR LOCK SWITCH
S-904	IN 14405, NEAR 1/8 TO GROUND EYELET
S-1004	IN 18C618, NEAR 1/8 TO L.H. LICENSE LAMP

ELECTRICAL SYSTEMS 1982 MUSTANG/CAPRI	
EFFECTIVE P.C.R.	HEATED BACKLITE
SUPERSEDES	POWER DOOR LOCKS
DATE 6-30-81	POWER WINDOWS

BEPE ELECT INST MAN PAGE E27-900-6  
SERVICE AND TRAINING MAN PAGE 6

**WIRING COLOR KEY (PRIMARY COLORS)**

BLACK	BK
BROWN	BR
TAN	T
RED	R
ORANGE	OR
PINK	PK
YELLOW	Y
DARK GREEN	DG
LIGHT GREEN	LG
DARK BLUE	DB
LIGHT BLUE	LB
PURPLE	P
GRAY	GY
WHITE	W
HASH	(H)
DOT	(D)

The presence of a tracer on the wire is indicated by a secondary color followed by an "H" for Hash or a "D" for Dot. A stripe is understood if no letter follows.

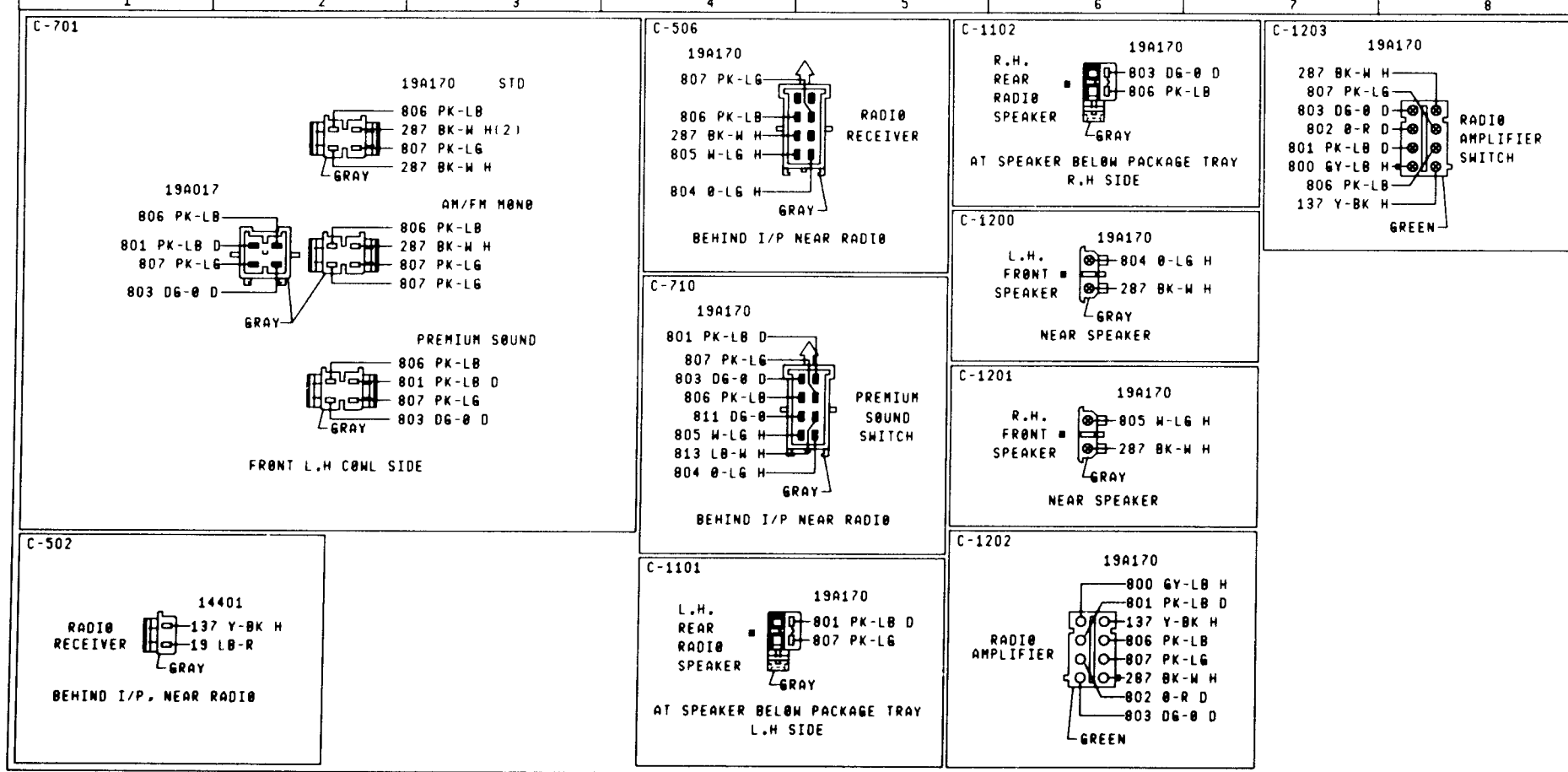
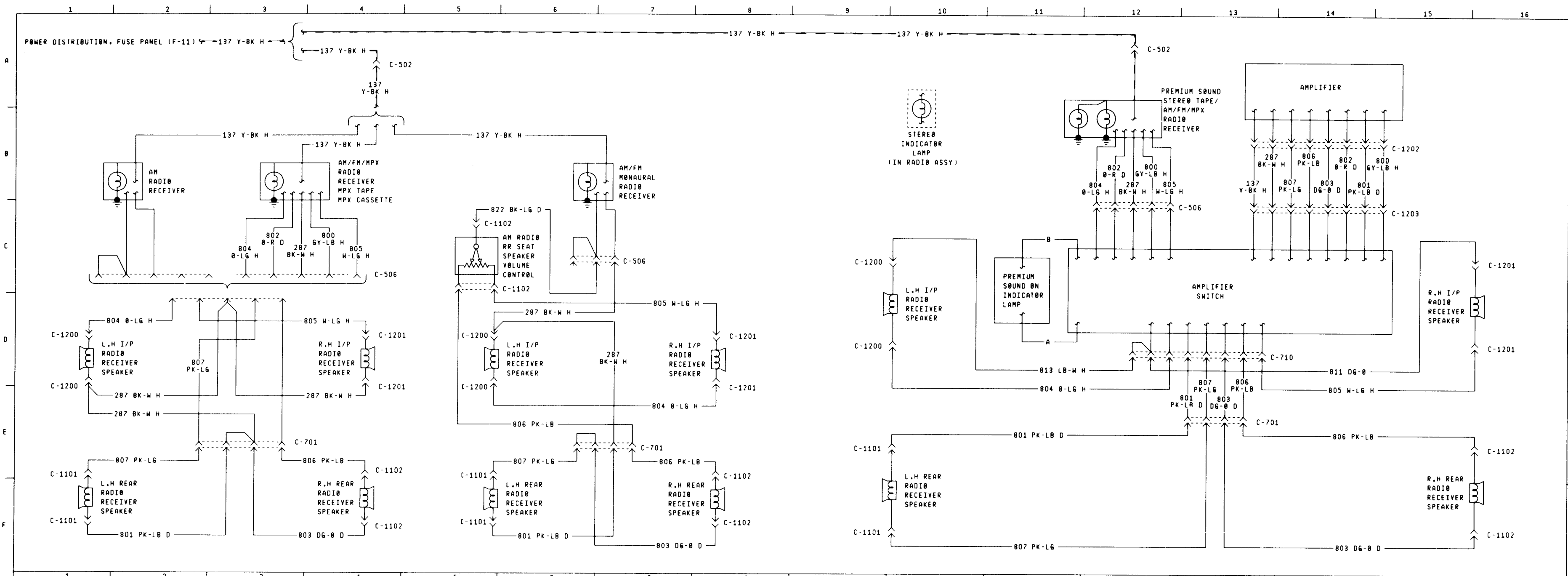

GROUND CODES	
SPLICE CODES	
ELECTRICAL SYSTEMS 1982 MUSTANG/CAPRI RADIO	
EFFECTIVE P.C.R. SUPERSEDES DATE 6-30-81	BEPE ELECT INST MAN PAGE E22-900-7 SERVICE AND TRAINING MAN PAGE 7

**WIRING COLOR KEY  
(PRIMARY COLORS)**

BLACK	BK
BROWN	BR
TAN	T
RED	R
PINK	PK
ORANGE	O
YELLOW	Y
DARK GREEN	DG
LIGHT GREEN	LG
DARK BLUE	DB
LIGHT BLUE	LB
PURPLE	P
GRAY	GY
WHITE	W
HASH	(H)
DOT	(D)

The presence of a tracer on the wire is indicated by a secondary color followed by an "H" for Hash or a "D" for Dot. A stripe is understood if no letter follows.



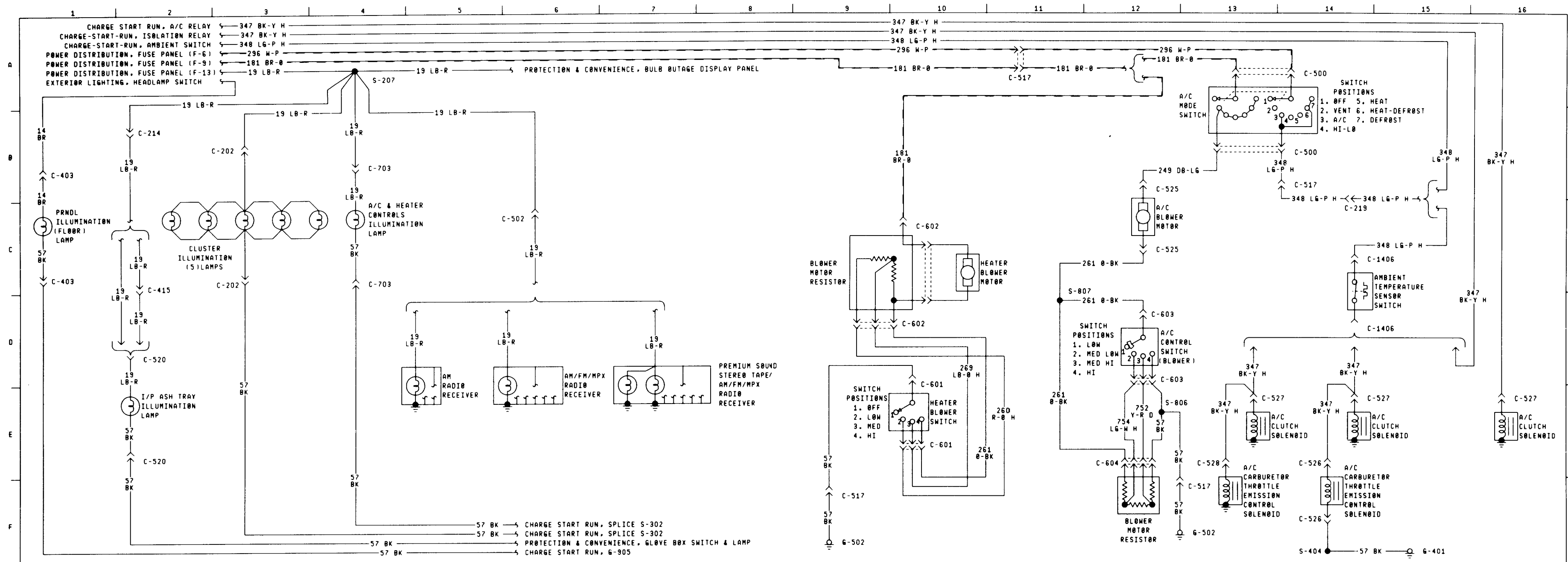

<b>C-202</b>  PRIMARY BEHIND I/P CLUSTER PRINTED CIRCUIT BOARD	<b>C-219</b>  ON PARKCHOP BRACE	<b>C-500</b>  BEHIND INSTRUMENT PANEL ON A/C SWITCH	<b>C-520</b>  ASH TRAY ILLUMINATION LAMP	<b>C-528</b>  A/C CARBURETOR THROTTLE EMISSION CONTROL SOLENOID	<b>C-604</b>  BEHIND I/P ON A/C PLENUM BELOW GLOVE BOX
<b>C-214</b>  LEFT OF HEADLAMP SWITCH	<b>C-415</b>  LEFT OF HEADLAMP SWITCH	<b>C-502</b>  BEHIND I/P, NEAR RADIO	<b>C-525</b>  PART OF A/C BLOWER MOTOR BEHIND INSTRUMENT PANEL, NEAR HEATER BLOWER MOTOR	<b>C-601</b>  BEHIND HEATER CONTROL SWITCH	<b>C-703</b>  BEHIND I/P AT A/C SWITCH OR HEATER
		<b>C-517</b>  BEHIND R.H. SIDE OF I/P	<b>C-526</b>  A/C CLUTCH SOLENOID	<b>C-602</b>  BEHIND I/P, ON HEATER PLENUM	<b>C-1406</b>  R.H. SIDE OF ENGINE COMPARTMENT
			<b>C-527</b>  A/C CLUTCH SOLENOID	<b>C-603</b>  BEHIND A/C BLOWER SWITCH	

**WIRING COLOR KEY (PRIMARY COLORS)**

BLACK	BK
BROWN	BR
TAN	T
RED	R
PINK	PK
ORANGE	O
YELLOW	Y
DARK GREEN	DG
LIGHT GREEN	LG
DARK BLUE	DB
LIGHT BLUE	LB
PURPLE	P
GRAY	GY
WHITE	W
HASH	(H)
DOT	(D)

**GROUND CODES**

G-401	EYELET ON 14290 NEAR L.H. HEADLAMP
G-502	IN 14401 BEHIND GLOVE BOX

**SPLICE CODES**

S-207	IN 14401 NEAR RADIO RECEIVER
S-404	IN 14290, NEAR GROUND TAKEOUT
S-806	IN 19949 NEAR A/C CONTROL SWITCH
S-807	IN 19949 NEAR BLOWER MOTOR RESISTOR

ELECTRICAL SYSTEMS 1982 MUSTANG/CAPRI ILLUMINATION LAMPS AIRCONDITIONER AND/OR HEATER  
 EFFECTIVE P.C.R. SUPERSEDES DATE 6-30-81  
 BEPE ELECT INST MAN PAGE E22-900-8 SERVICE AND TRAINING MAN PAGE 8

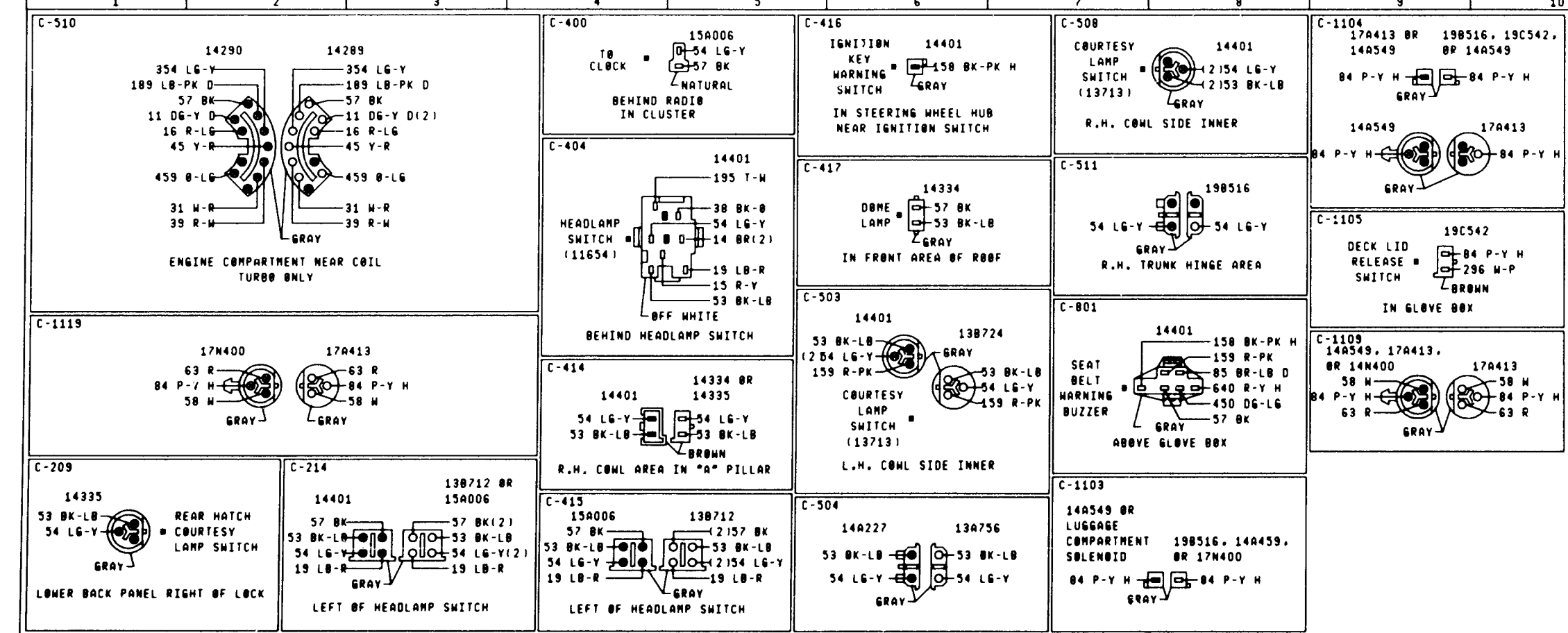
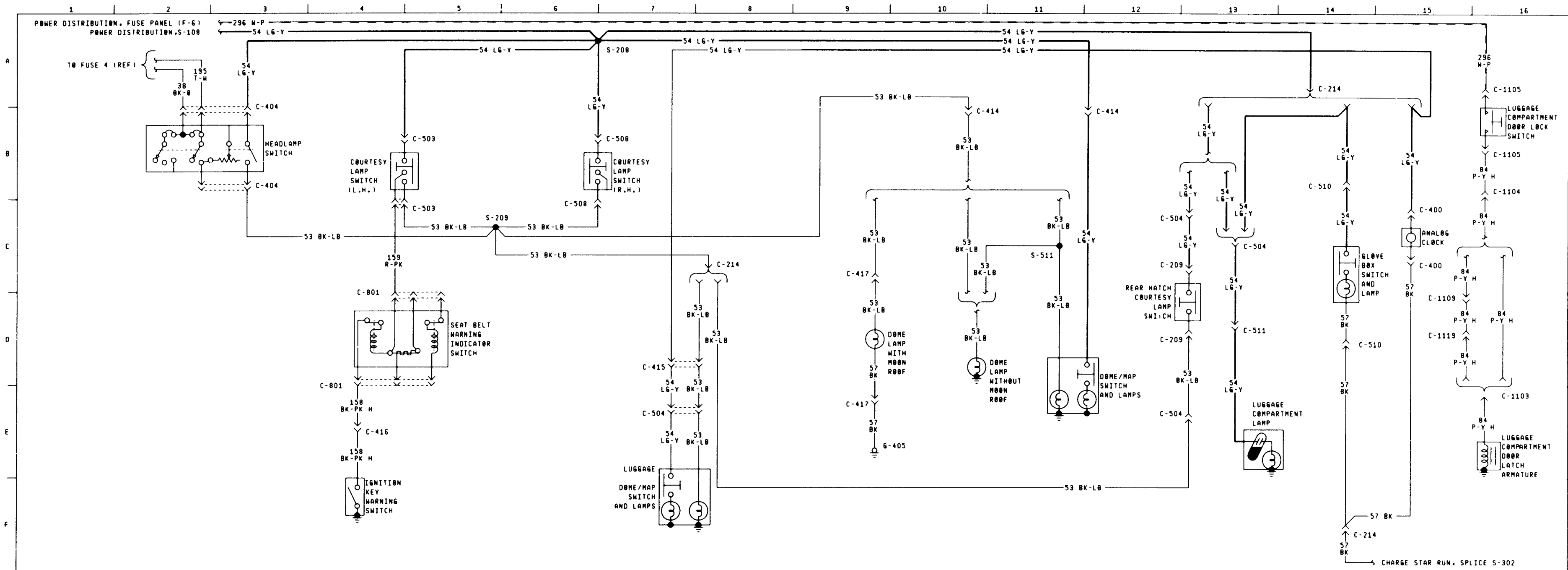

**WIRING COLOR KEY (PRIMARY COLORS)**

BLACK	BK
BROWN	BR
TAN	T
RED	R
PINK	PK
ORANGE	O
YELLOW	Y
DARK GREEN	DG
LIGHT GREEN	LG
DARK BLUE	DB
LIGHT BLUE	LB
PURPLE	P
GRAY	GY
WHITE	W
HASH	(H)
DOT	(D)

**GROUND CODES**

G-405	EYELET ON 14334 FOR GROUNDING DOME LAMP
-------	---

**SPLICE CODES**

S-208	IN 14401 NEAR FUSE PANEL
S-209	IN 14401 NEAR FUSE PANEL
S-511	IN 14335, NEAR T/O TO DOME LAMP

**ELECTRICAL SYSTEMS 1982 MUSTANG/CAPRI PROTECTION AND CONVENIENCE**

EFFECTIVE P.C.R. SUPERSEDES DATE 6-30-81

BEPE ELECT INST MAN PAGE E22-900-9 SERVICE AND TRAINING MAN PAGE 9

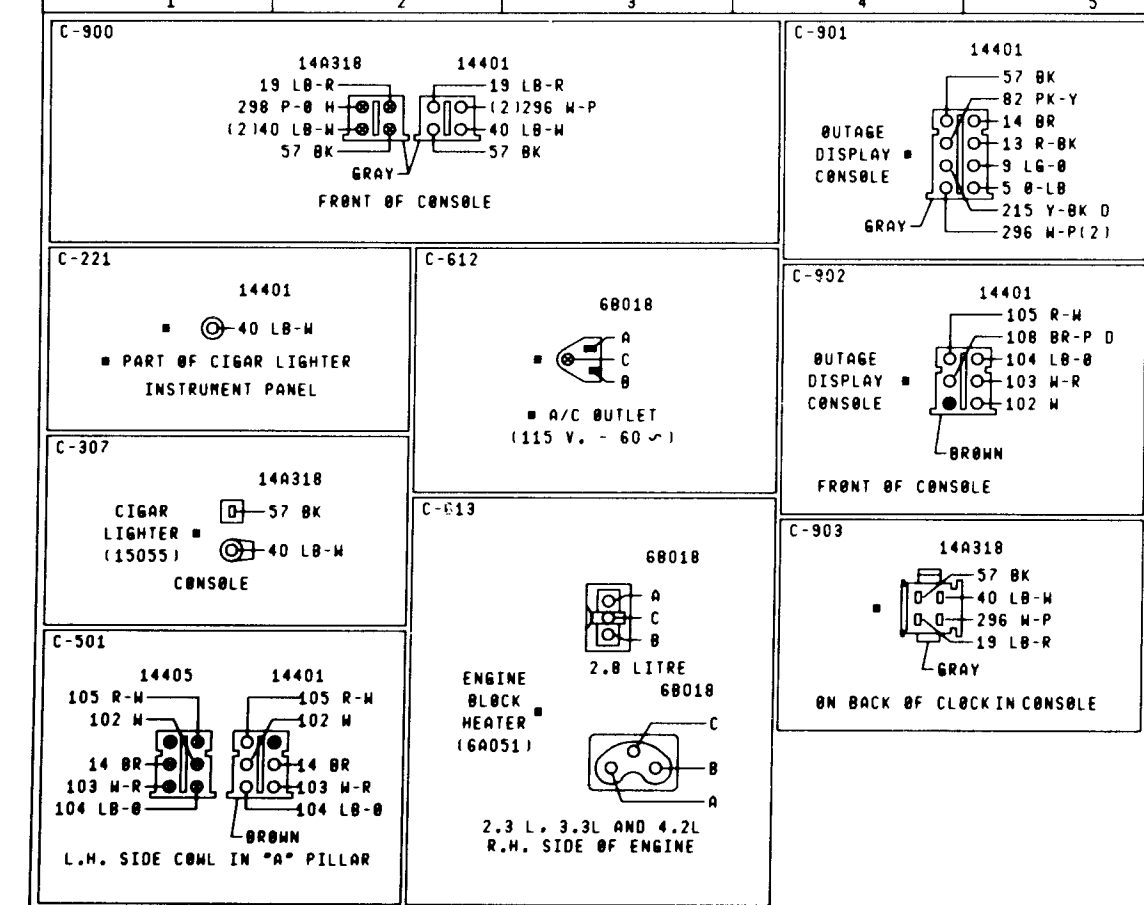
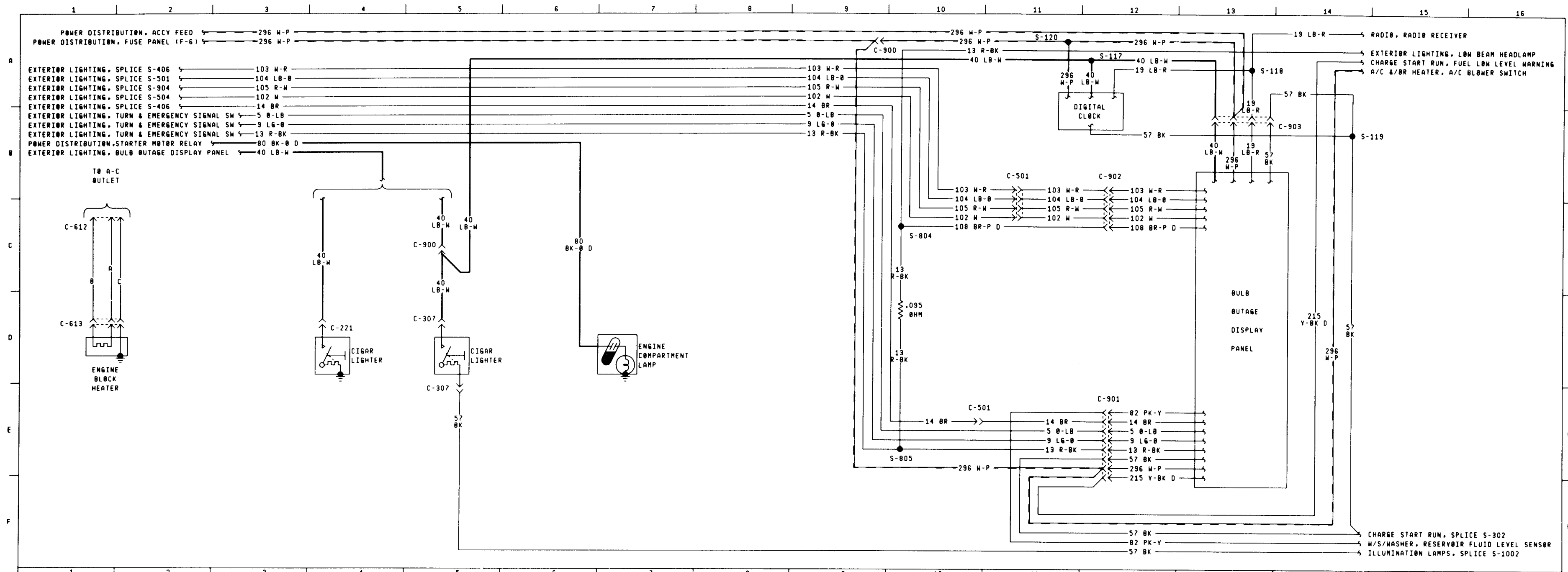

**WIRING COLOR KEY (PRIMARY COLORS)**

- BLACK BK
- BROWN BR
- TAN T
- RED R
- PINK PK
- ORANGE O
- YELLOW Y
- DARK GREEN DG
- LIGHT GREEN LG
- DARK BLUE DB
- LIGHT BLUE LB
- PURPLE P
- GRAY GY
- WHITE W
- HASH (H)
- DOT (D)

GROUND CODES	
SPlice CODES	
S-117	IN 14401, NEAR CLOCK
S-118	IN 14401, NEAR CLOCK
S-119	IN 14401, NEAR CLOCK
S-120	IN 14401, NEAR CLOCK
S-804	IN 14401, NEAR T/O TO SEAT BELT WARNING BUZZER
S-805	IN 14401, NEAR T/O TO B/U LAMP SWITCH
ELECTRICAL SYSTEMS 1982 MUSTANG/CAPRI	
EFFECTIVE P.C.R.	PROTECTION AND CONVENIENCE
SUPERSEDES	ENGINE COMPARTMENT LAMP
DATE 6-30-81	IMMERSION HEATER
BEPE ELECT INST MAN PAGE E22-900-10	
SERVICE AND TRAINING MAN PAGE 10	

The presence of a tracer on the wire is indicated by a secondary color followed by an "H" for Hash or a "D" for Dot. A stripe is understood if no letter follows.

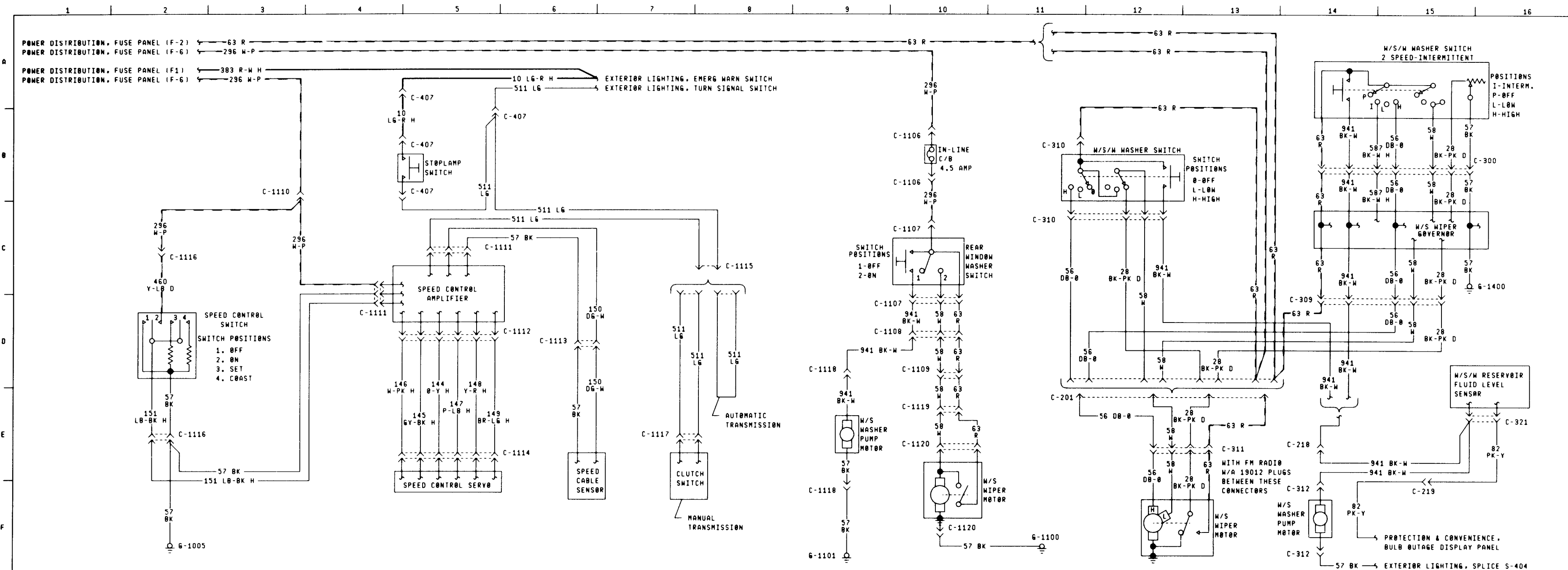

C-1118  
 17A413  
 WINDSHIELD WASHER PUMP MOTOR  
 57 BK  
 941 BK-W  
 NATURAL  
 BELOW REAR WINDOW

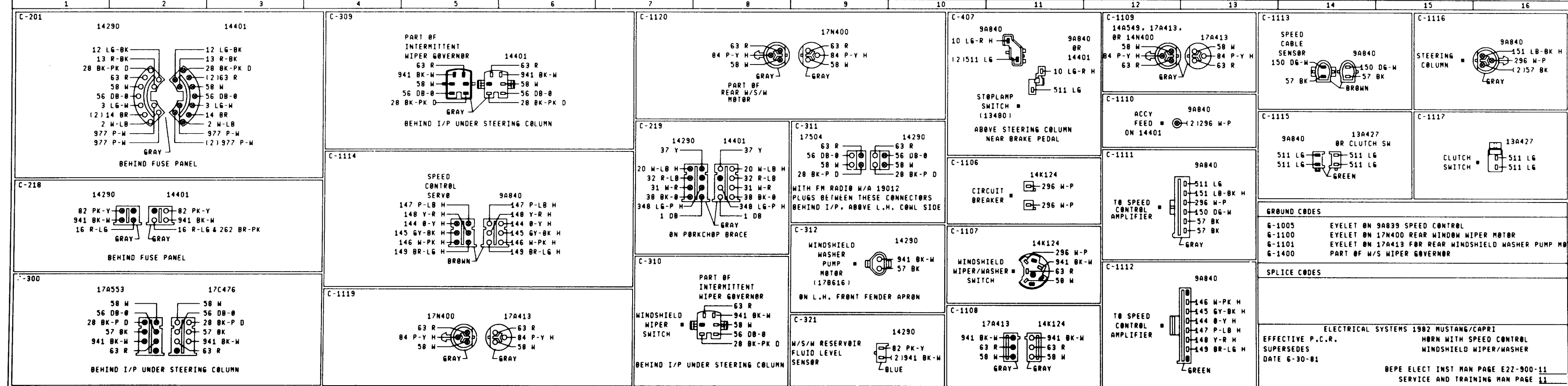

**WIRING COLOR KEY (PRIMARY COLORS)**

BLACK	BK
BROWN	BR
TAN	T
RED	R
PINK	PK
ORANGE	O
YELLOW	Y
DARK GREEN	DG
LIGHT GREEN	LG
DARK BLUE	DB
LIGHT BLUE	LB
PURPLE	P
GRAY	GY
WHITE	W
HASH	(H)
DOT	(D)

The presence of a tracer on the wire is indicated by a secondary color followed by an 'H' for Hash or a 'D' for Dot. A stripe is understood if no letter follows.

**GROUND CODES**

G-1005 EYELET ØN 9A839 SPEED CONTROL  
 G-1100 EYELET ØN 17N400 REAR WINDOW WIPER MOTOR  
 G-1101 EYELET ØN 17A413 FOR REAR WINDSHIELD WASHER PUMP MOTOR

**SPLICE CODES**

ELECTRICAL SYSTEMS 1982 MUSTANG/CAPRI  
 HORN WITH SPEED CONTROL  
 WINDSHIELD WIPER/WASHER  
 EFFECTIVE P.C.R.  
 SUPERSEDES  
 DATE 6-30-81

BEPE ELECT INST MAN PAGE E22-900-11  
 SERVICE AND TRAINING MAN PAGE 11