

**PROJECT SUMMARY: PARKING LOT CONSTRUCTION 0.61 ACRES**

PROJECT SCOPE: TO CONSTRUCT A PARKING LOT OF APPROXIMATELY 0.61 ACRES. THE PROJECT WILL INCLUDE THE REMOVAL OF TREES, EXCAVATION, AND DISPOSAL OF APPROXIMATELY 10,500 CUBIC YARDS OF MUSKEG, AND PLACEMENT OF APPROXIMATELY 9,530 CUBIC YARDS OF SHOTROCK WITH APPROXIMATELY 500 CUBIC YARDS OF GRAVEL TOPPING. APPROXIMATELY 150 LINEAR FEET OF ROCK RETAINING WALL WILL BE CONSTRUCTED ALONG WITH 300 LINEAR FEET OF PERIMETER ROCK AROUND THE PARKING LOT. A STORMWATER AREA DRAIN WILL BE INSTALLED TO THE EXISTING STORM DRAIN SYSTEM.

**INDEX OF SHEETS**

SHEET NO.	DESCRIPTION
1.	TITLE SHEET
2.	QUANTITIES & GENERAL NOTES
3.	CONSTRUCTION SITE PLAN
4.	EXISTING SITE AND UTILITIES
5.	GRADING PLAN
6.	DETAILS - CROSS SECTION
7.	DETAILS - ROCK WALL
8.	DETAILS - AREA DRAIN DETAILS

# PETERSBURG INDIAN ASSOCIATION

P.O. BOX 1410, PETERSBURG, ALASKA 99833, (907) 772-3636



## 12th & Howkan Lot Revitalization Project PHASE I ~ 2023 ~

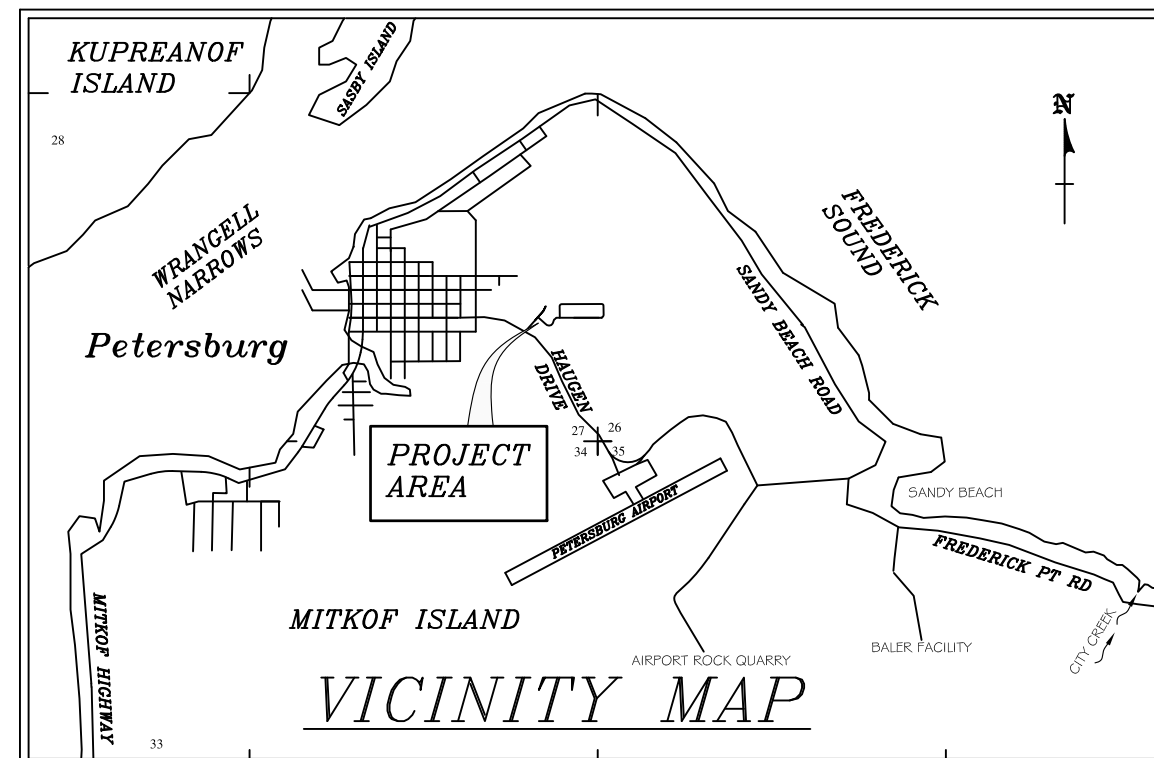
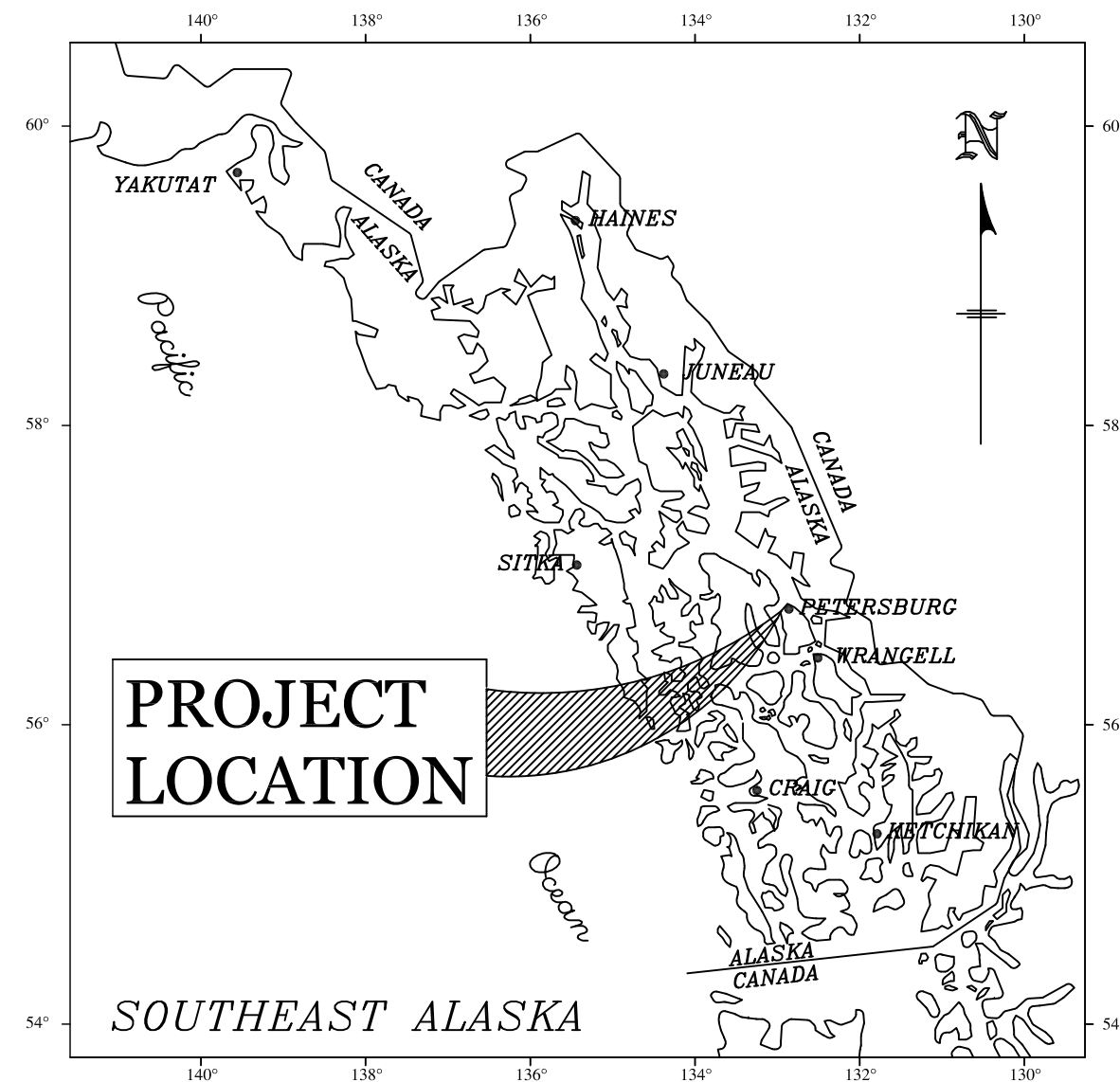

APPROVED:  
*Chris Morrison* 7/19/2023  
PIA PRESIDENT - Chris Morrison DATE

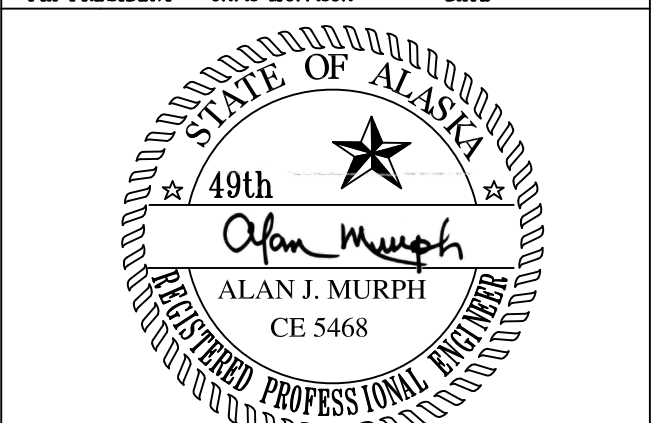

DESIGNED BY:  
HARAI & ASSOCIATES, INC  
P.O. BOX 625  
PETERSBURG, ALASKA 99833  
JUNE, 2023

**ESTIMATE OF QUANTITIES**

ITEM NO.	ITEM DESCRIPTION	PAY UNIT	BID QUANTITY	ESTIMATED QUANTITY
1510.1	MOBILIZATION	LUMP SUM	ALL REQUIRED	
2004.1	CLEARING AND GRUBBING	LUMP SUM	ALL REQUIRED	APPROXIMATELY 26,550 S.F. = 0.61 ACRES
2010.1	EXCAVATION - MUSKEG	LUMP SUM	ALL REQUIRED	APPROXIMATELY 10,500 C.Y.
2021.1	EMBANKMENT 12" MINUS SHOT ROCK	LUMP SUM	ALL REQUIRED	APPROXIMATELY 9,530 C.Y.
2022.1	CRUSHED GRAVEL TOPPING	LUMP SUM	ALL REQUIRED	APPROXIMATELY 500 C.Y.
5505.1	CATCH BASIN	LUMP SUM	ALL REQUIRED	ONE
7021.1	ROCK WALL	LUMP SUM	ALL REQUIRED	APPROXIMATE ROCK WALL = 150 L.F. PERIMETER ROCK = 300 L.F.
7030.1	EROSION & SEDIMENT CONTROL	LUMP SUM	ALL REQUIRED	
7530.1	FINAL PROJECT CLEAN UP	LUMP SUM	ALL REQUIRED	

**GENERAL NOTES**

1. PETERSBURG BOROUGH STANDARD SPECIFICATIONS ~ 2012, APPLIES TO THESE PLANS AND SPECIFICATIONS. PETERSBURG INDIAN ASSOCIATION WILL BE THE ADMINISTRATIVE AUTHORITY, NOT PETERSBURG BOROUGH.
2. THE CONTRACTOR WILL FURNISH TO THE ENGINEER A WORK PLAN THAT DETAILS CONSTRUCTION DATES, TRAFFIC AND SAFETY PLANS. CONTRACTOR WILL ALSO FURNISH TO THE ENGINEER MATERIAL CERTIFICATION SHEETS TO SHOW THAT ALL MATERIAL USED IN THIS PROJECT MEETS THE SPECIFICATIONS OF THESE PLANS AND CITY OF PETERSBURG STANDARD SPECIFICATIONS ~ 2012.
3. SAFETY AND PUBLIC ACCESS. CONTRACTOR IS RESPONSIBLE FOR ALL NECESSARY SAFETY BARRIERS, SIGNAGE AND TRAFFIC CONTROL NECESSARY FOR SAFE OPERATION TO THE PUBLIC. THE SIDEWALK AND ROAD WILL REMAIN OPEN TO THE PUBLIC. THE CONTRACTOR MAY CLOSE OFF THE PROJECT AREA.
4. SITE CLEAN UP. CONTRACTOR SHALL CLEANUP SITE OF ALL CONSTRUCTION MATERIAL AND CONSTRUCTION TRASH AND DISPOSE OF AT A SITE APPROVED BY THE ENGINEER.
5. SIDEWALKS DAMAGED DURING CONSTRUCTION WILL BE REBUILT AT THE CONTRACTOR'S EXPENSE. ALL SIDEWALK CROSSINGS USED BY EQUIPMENT WILL BE PROTECTED WITH  $\frac{3}{4}$ " STEEL PLATE THAT COMPLETELY COVERS THE SIDEWALK PLUS A FOOT ON EACH SIDE.
6. HOURS OF CONSTRUCTION WORK WILL BE BETWEEN 7AM TILL 7 PM, MONDAY THROUGH SUNDAY.

**DRAWING:**  
PROJECT  
QUANTITIES &  
GENERAL NOTES

**PROJECT:** 12th & Howkan Lot  
Revitalization Project  
PHASE I  
~PETERSBURG, ALASKA~

**PETERSBURG INDIAN  
ASSOCIATION**  
P.O. BOX 1410, PETERSBURG, AK. 99833  
(907) 772-3636

REVISIONS		
REV	DATE	DESCRIPTION

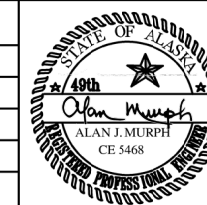

DESIGNED BY:  
HARAI & ASSOCIATES, INC  
P.O. BOX 625, PETERSBURG, ALASKA 99833

DATE: JUNE, 2023

<b>SHEET NUMBER</b>	<b>TOTAL SHEETS</b>
2	8

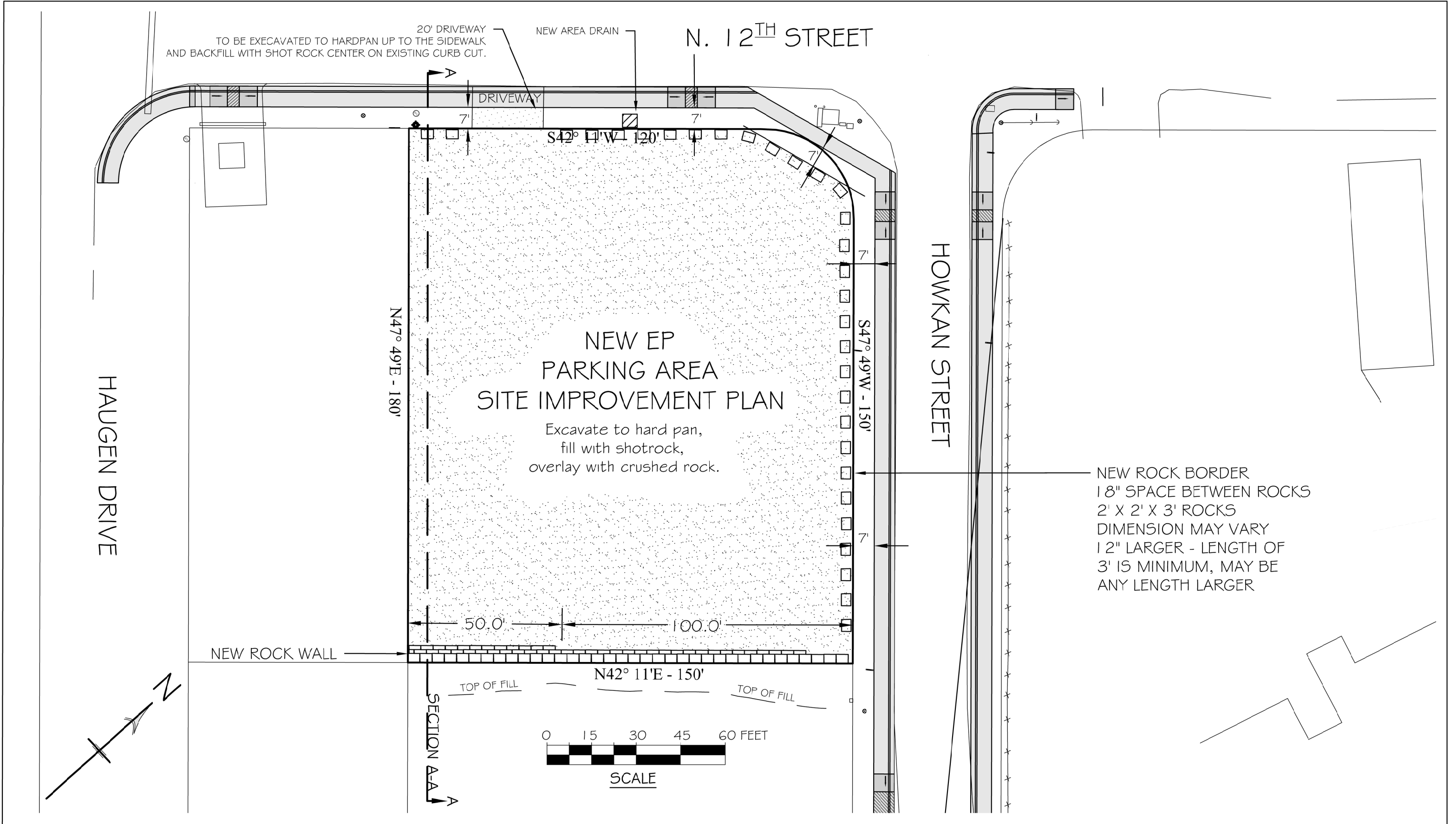

**DRAWING:**  
SITE PLAN

**PROJECT:** 12th & Howkan Lot  
Revitalization Project  
PHASE I  
~PETERSBURG, ALASKA~

**PETERSBURG INDIAN ASSOCIATION**  
P.O. BOX 1410, PETERSBURG, AK. 99833  
(907) 772-3636

REVISIONS		
REV	DATE	DESCRIPTION

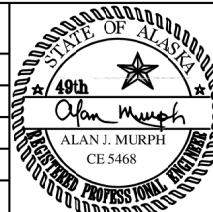

DESIGNED BY:  
HARAI & ASSOCIATES, INC  
P.O. BOX 625, PETERSBURG, ALASKA 99833  
DATE: JUNE, 2023

<b>SHEET NUMBER</b> 3	<b>TOTAL SHEETS</b> 8
--------------------------	--------------------------

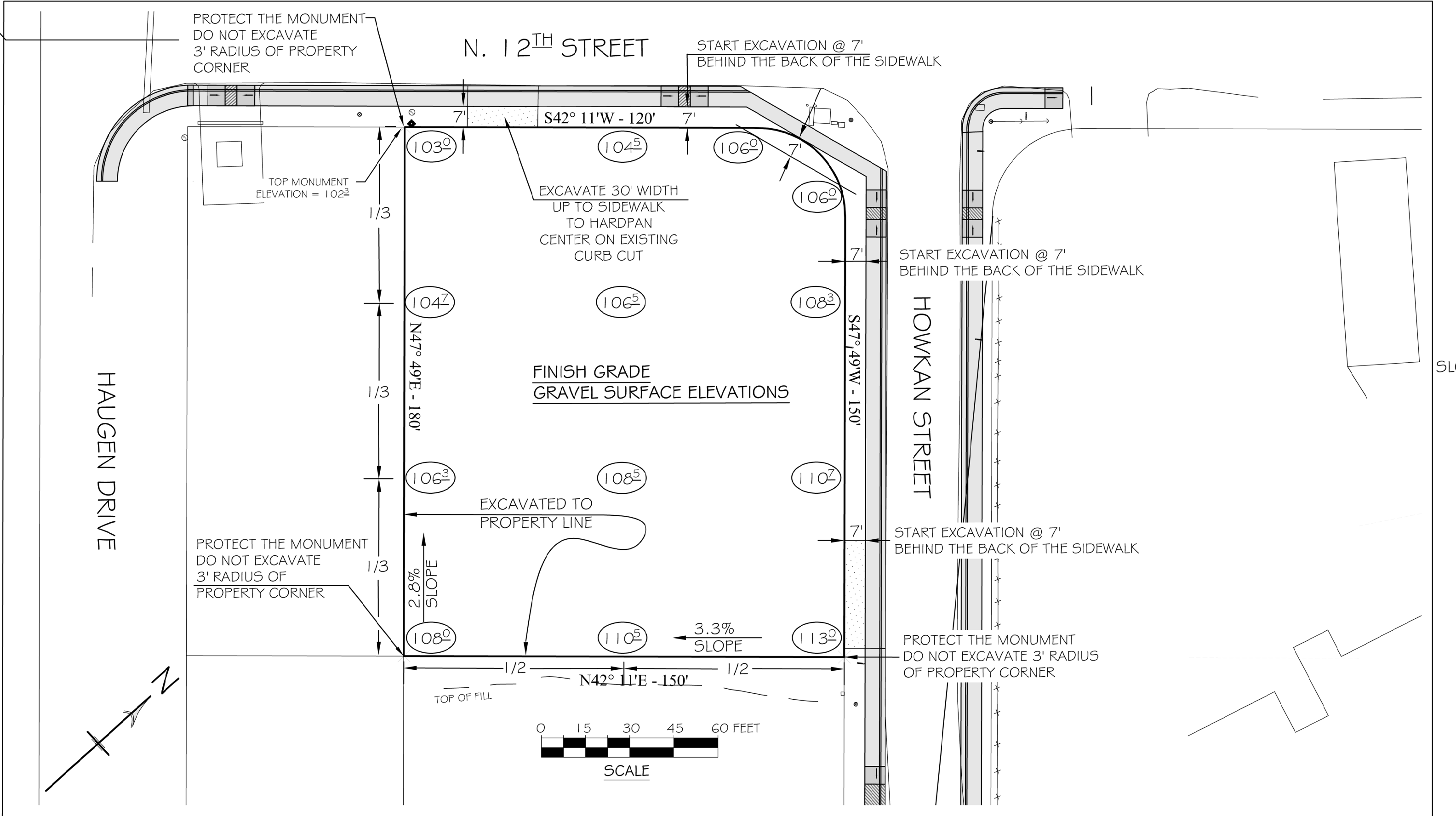

**DRAWING:**  
GRADING PLAN

**PROJECT:** 12th & Howkan Lot  
Revitalization Project  
PHASE I  
~PETERSBURG, ALASKA~

**PETERSBURG INDIAN ASSOCIATION**  
P.O. BOX 1410, PETERSBURG, AK. 99833  
(907) 772-3636

REVISIONS		
REV	DATE	DESCRIPTION

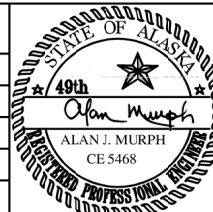

DESIGNED BY:  
HARAI & ASSOCIATES, INC  
P.O. BOX 625, PETERSBURG, ALASKA 99833  
DATE: JUNE, 2023

<b>SHEET NUMBER</b> 4	<b>TOTAL SHEETS</b> 8
--------------------------	--------------------------

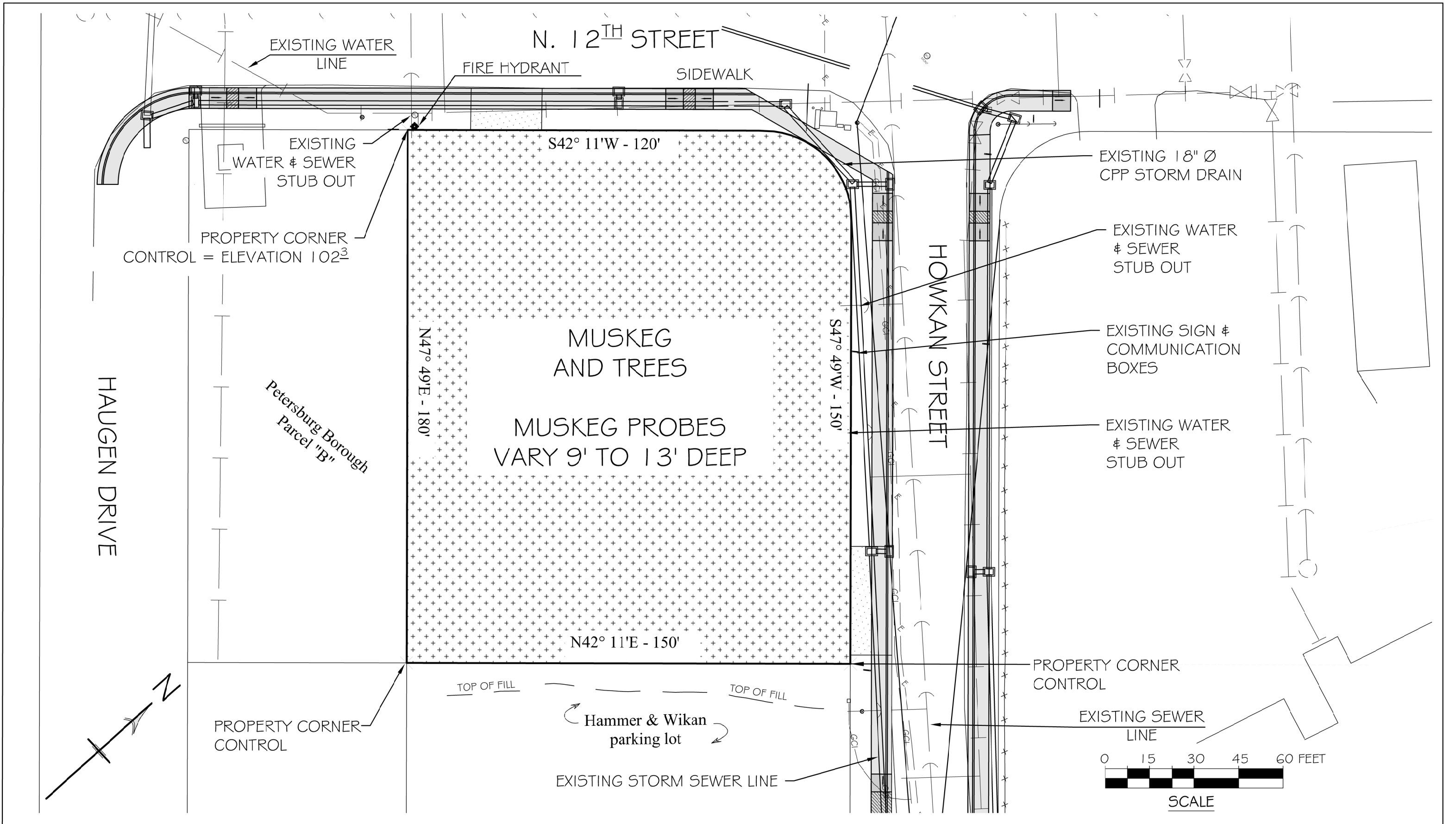

**DRAWING:**  
EXISTING  
SITE & UTILITIES

**PROJECT:** 12th & Howkan Lot  
Revitalization Project  
PHASE I  
~PETERSBURG, ALASKA~

**PETERSBURG INDIAN  
ASSOCIATION**  
P.O. BOX 1410, PETERSBURG, AK. 99833  
(907) 772-3636

REVISIONS		
REV	DATE	DESCRIPTION

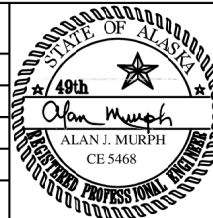

DESIGNED BY:  
HARAI & ASSOCIATES, INC  
P.O. BOX 625, PETERSBURG, ALASKA 99833

DATE: JUNE, 2023

SHEET NUMBER	TOTAL SHEETS
5	8

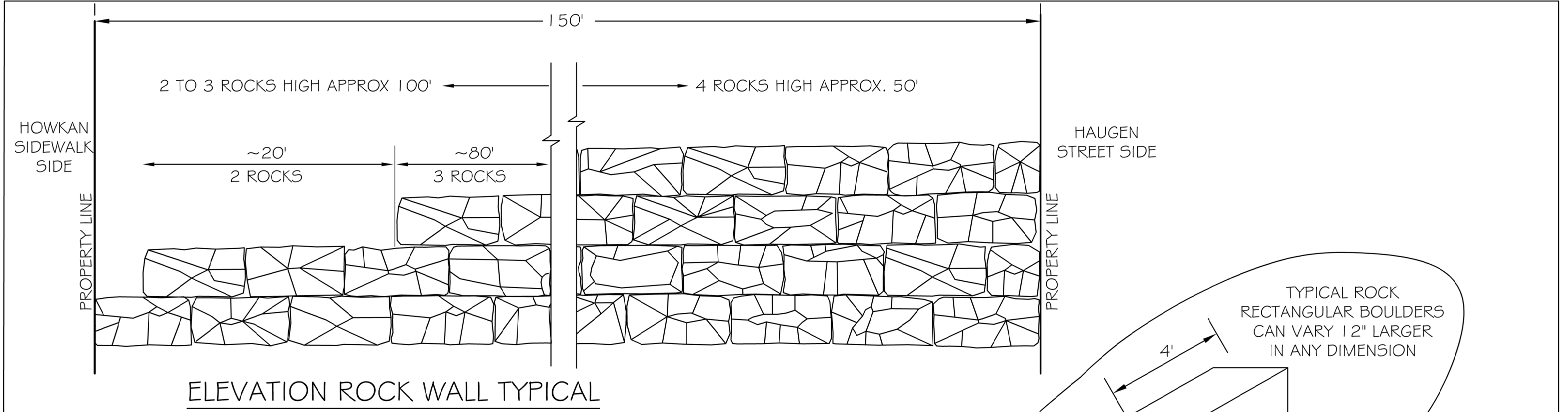

ELEVATION ROCK WALL TYPICAL

1. STAGGER AND INTERLOCK ROCKS FOR STABILITY.
2. THE HIGHEST WALL WILL BE A MAXIMUM OF 4 ROCKS TAPERING TO 2 ROCKS - ENGINEER APPROVAL.

CROSS SECTION ROCK WALL TYPICAL

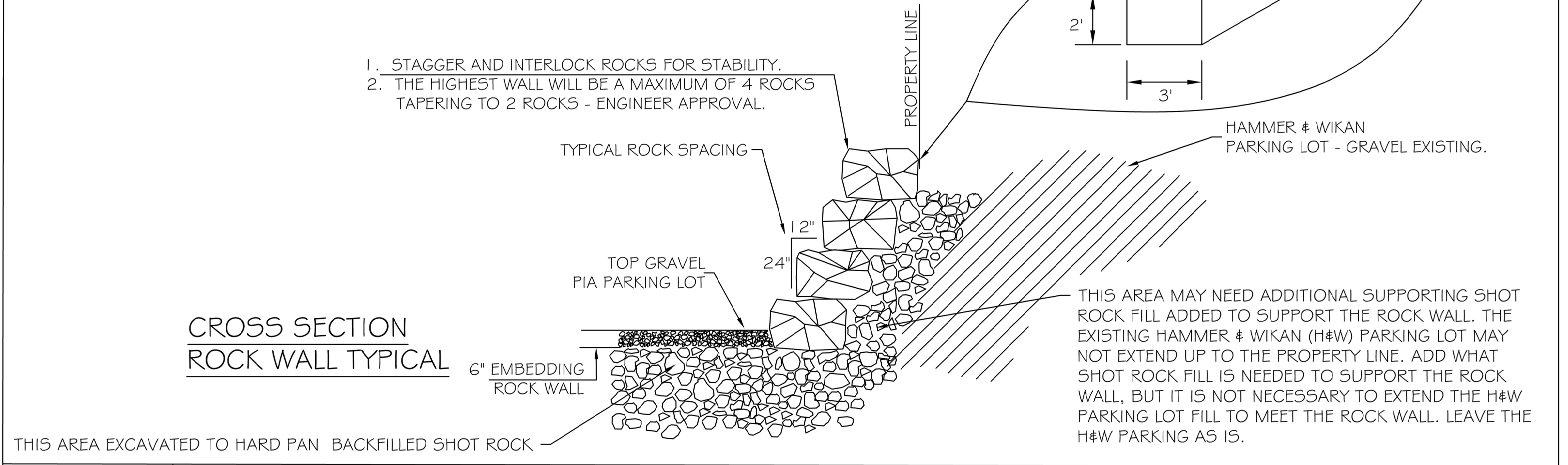

THIS AREA EXCAVATED TO HARD PAN BACKFILLED SHOT ROCK

**DRAWING:**  
RETAINING WALL

**PROJECT:** 12th & Howkan Lot Revitalization Project PHASE I  
~PETERSBURG, ALASKA~

**PETERSBURG INDIAN ASSOCIATION**  
P.O. BOX 1410, PETERSBURG, AK. 99833  
(907) 772-3636

REVISIONS		
REV	DATE	DESCRIPTION

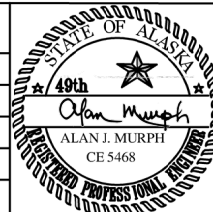

DESIGNED BY:  
HARAI & ASSOCIATES, INC  
P.O. BOX 625, PETERSBURG, ALASKA 99833

DATE: JUNE, 2023

SHEET NUMBER 6	TOTAL SHEETS 8
-------------------	-------------------

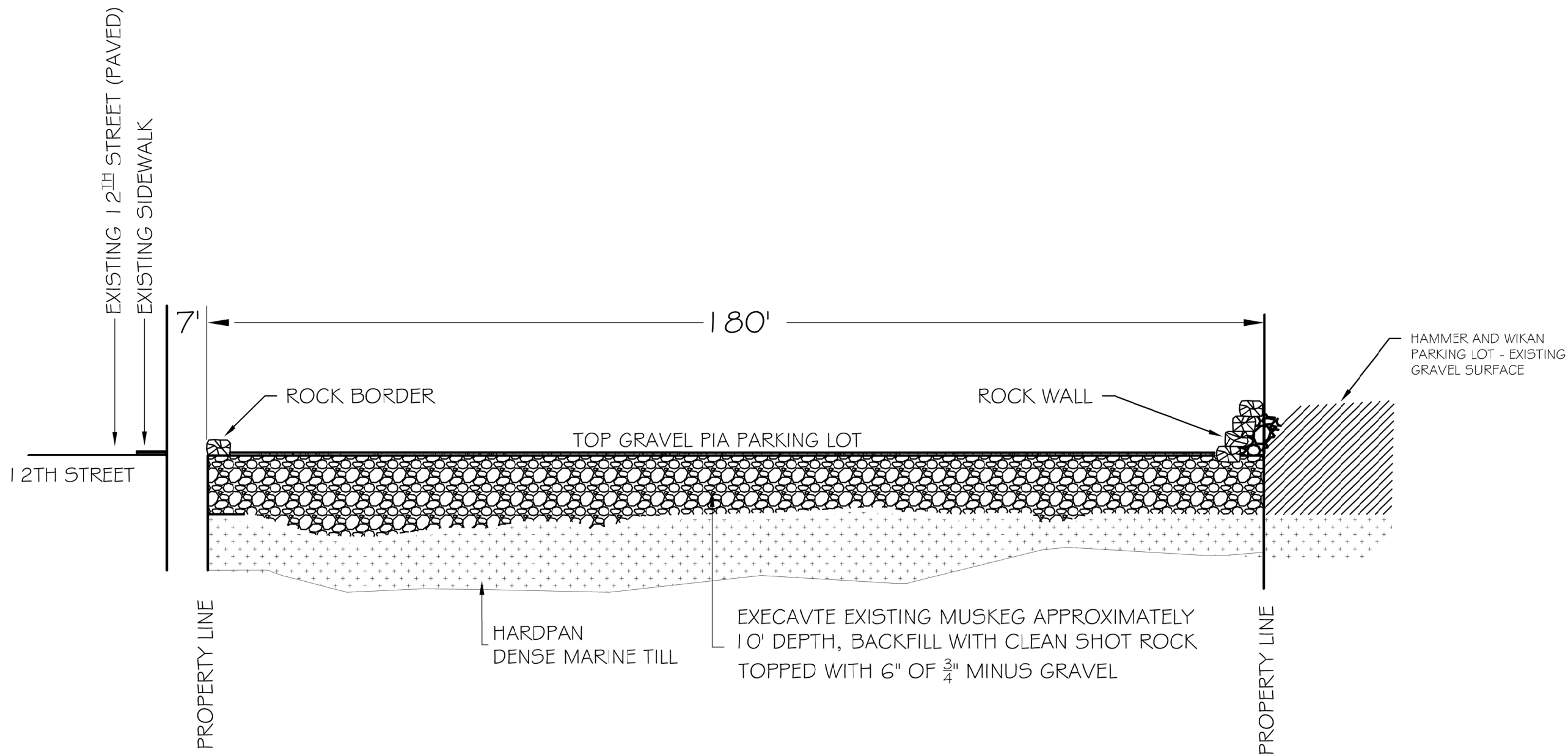

TYPICAL SECTION A-A

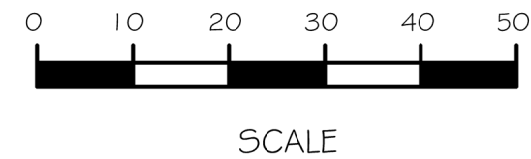

DRAWING:  
PARKING  
LOT  
CROSS SECTION

PROJECT: 12th & Howkan Lot  
Revitalization Project  
PHASE I  
~PETERSBURG, ALASKA~

**PETERSBURG INDIAN  
ASSOCIATION**  
P.O. BOX 1410, PETERSBURG, AK. 99833  
(907) 772-3636

REVISIONS		
REV	DATE	DESCRIPTION

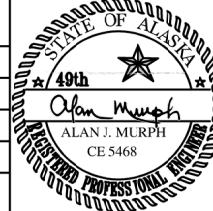

DESIGNED BY:  
HARAI & ASSOCIATES, INC  
P.O. BOX 625, PETERSBURG, ALASKA 99833  
DATE: JUNE, 2023  
SHEET NUMBER 7 TOTAL SHEETS 8



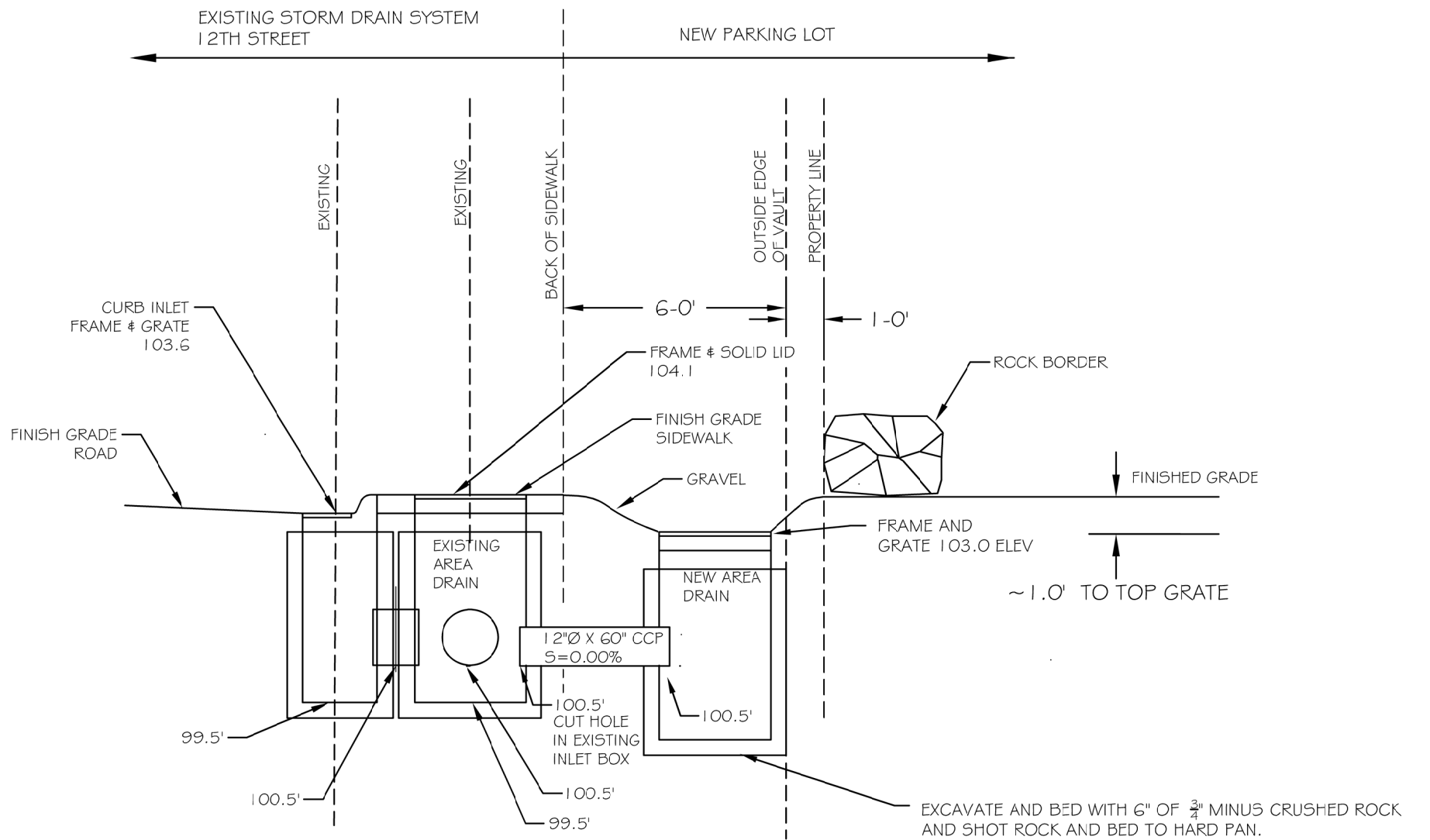
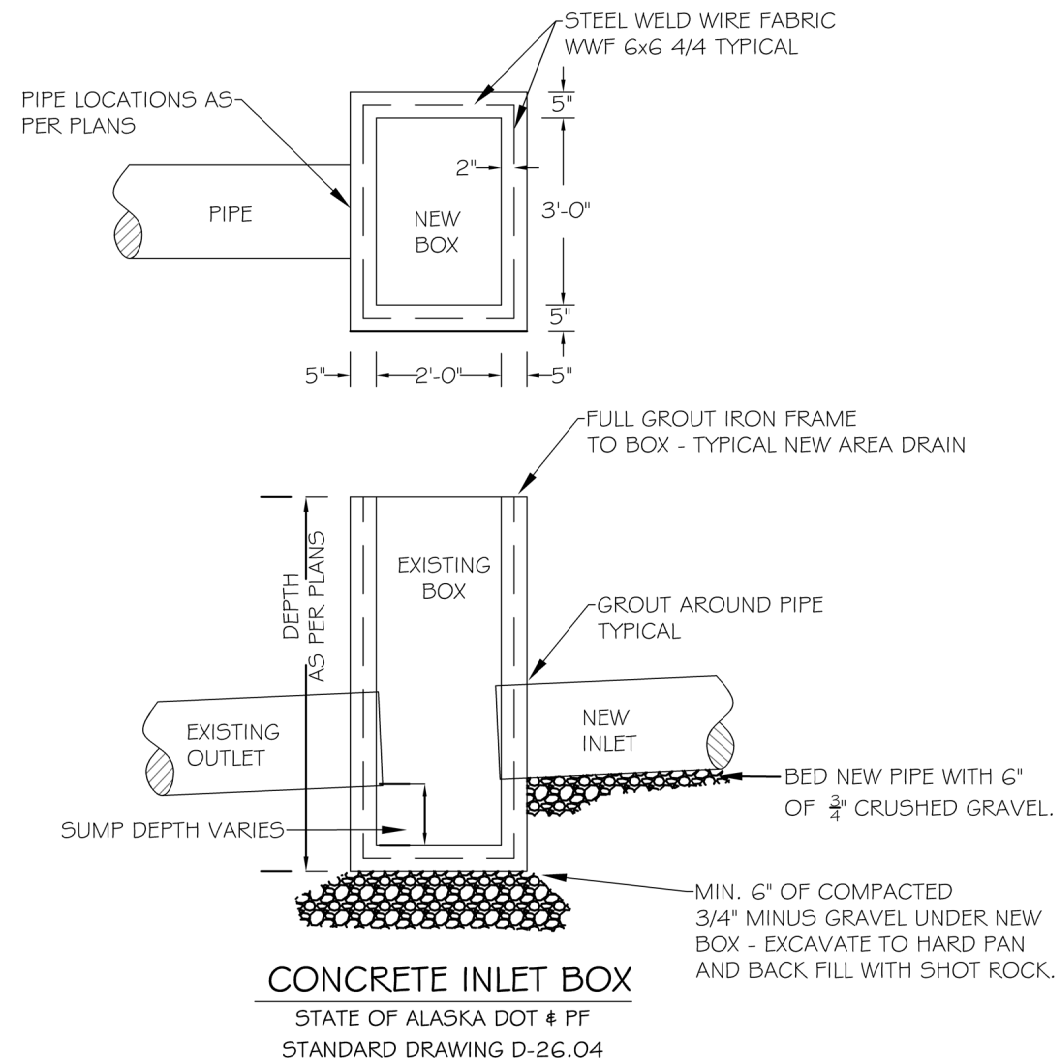

NOTE:  
 AREA DRAIN = NEENAH FOUNDRY INC., MODEL #R-1878-B7G  
 OR APPROVED EQUAL

DRAWING:  
**AREA DRAIN  
 DETAILS**

PROJECT: **12th & Howkan Lot  
 Revitalization Project  
 PHASE I  
 ~PETERSBURG, ALASKA~**

**PETERSBURG INDIAN  
 ASSOCIATION**  
 P.O. BOX 1410, PETERSBURG, AK. 99833  
 (907) 772-3636

REVISIONS		
REV	DATE	DESCRIPTION

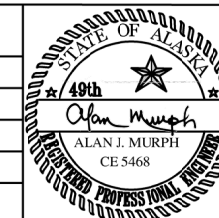

DESIGNED BY:  
**HARAI & ASSOCIATES, INC**  
 P.O. BOX 625, PETERSBURG, ALASKA 99833  
 DATE: **JUNE, 2023**

<b>SHEET NUMBER</b>	<b>TOTAL SHEETS</b>
<b>8</b>	<b>8</b>