

DENSO

Diesel Injection Pump

SERVICE MANUAL

COMMON RAIL SYSTEM (CRS)

OPERATION

September, 2007

DENSO CORPORATION

00400534E

© 2007 DENSO CORPORATION

All Rights Reserved. This book may not be reproduced or copied, in whole or in part, without the written permission of the publisher.

Revision History

Date	Revision Contents
2007. 09	<ul style="list-style-type: none">• SCV: Explanation of compact SCV added to "Suction Control Valve (SCV)". (Operation: Refer to page 1-30.)• "Repair" section added.

Table of Contents

Operation Section

1. GENERAL DESCRIPTION

1.1	Changes In Environment Surrounding The Diesel Engine	1-1
1.2	Demands On Fuel Injection System	1-2
1.3	Types Of And Transitions In ECD (ELECTRONICALLY CONTROLLED DIESEL) Systems	1-3
1.4	Common Rail System Characteristics	1-4
1.5	Common Rail System And Supply Pump Transitions	1-5
1.6	Injector Transitions	1-5
1.7	Common Rail System Configuration	1-6

2. COMMON RAIL SYSTEM OUTLINE

2.1	Layout of Main Components	1-7
-----	---------------------------	-----

3. SUPPLY PUMP DESCRIPTION

3.1	HP0 Type	1-12
3.2	HP2 Type	1-18
3.3	HP3 Type	1-27
3.4	HP4 Type	1-41

4. RAIL DESCRIPTION

4.1	Rail Functions and Composition	1-46
4.2	Component Part Construction and Operation	1-46

5. INJECTOR DESCRIPTION

5.1	General Description	1-50
5.2	Injector Construction and Features	1-51
5.3	Injector Operation	1-54
5.4	Injector Actuation Circuit	1-54
5.5	Other Injector Component Parts	1-56

6. DESCRIPTION OF CONTROL SYSTEM COMPONENTS

6.1	Engine Control System Diagram (Reference)	1-59
6.2	Engine ECU (Electronic Control Unit)	1-60
6.3	EDU (Electronic Driving Unit)	1-60
6.4	Various Sensors	1-61

7. CONTROL SYSTEM

7.1	Fuel Injection Control	1-66
7.2	E-EGR System (Electric-Exhaust Gas Recirculation)	1-76
7.3	Electronically Controlled Throttle (Not Made By DENSO)	1-78
7.4	Exhaust Gas Control System	1-79
7.5	DPF System (Diesel Particulate Filter)	1-80
7.6	DPNR SYSTEM (DIESEL PARTICULATE NO _x REDUCTION)	1-82

8. DIAGNOSIS

8.1	Outline Of The Diagnostic Function.	1-83
8.2	Diagnosis Inspection Using DST-1	1-83
8.3	Diagnosis Inspection Using The MIL (Malfunction Indicator Light)	1-84
8.4	Throttle Body Function Inspection	1-86

9. END OF VOLUME MATERIALS

9.1	Particulate Matter (PM)	1-87
9.2	Common Rail Type Fuel Injection System Development History And The World's Manufacturers.	1-87
9.3	Higher Injection Pressure, Optimized Injection Rates, Higher Injection Timing Control Precision, Higher Injection Quantity Control Precision.	1-88
9.4	Image Of Combustion Chamber Interior	1-90

Repair Section**1. DIESEL ENGINE MALFUNCTIONS AND DIAGNOSTIC METHODS (BASIC KNOWLEDGE)**

1.1	Combustion State and Malfunction Cause	2-91
1.2	Troubleshooting.	2-92

2. DIAGNOSIS OVERVIEW

2.1	Diagnostic Work Flow	2-93
2.2	Inquiries.	2-94
2.3	Non-Reoccurring Malfunctions	2-96

3. DTC READING (FOR TOYOTA VEHICLES)

3.1	DST-2	2-98
3.2	DTC Check (Code Reading via the DST-2).	2-98
3.3	DTC Memory Erasure (via the DST-2)	2-98

4. TROUBLESHOOTING BY SYSTEM

4.1	Intake System Diagnosis	2-99
4.2	Fuel System Diagnosis	2-99
4.3	Basics of Electrical/Electronic Circuit Checks	2-102

5. TROUBLESHOOTING

5.1	Troubleshooting According to Malfunction Symptom (for TOYOTA Vehicles).	2-107
5.2	Other Malfunction Symptoms	2-122

6. DIAGNOSIS CODES (DTC)

6.1	DTC Chart (Example)	2-124
-----	-------------------------------	-------

1. GENERAL DESCRIPTION

1.1 Changes In Environment Surrounding The Diesel Engine

- Throughout the world, there is a desperate need to improve vehicle fuel economy for the purposes of preventing global warming and reducing exhaust gas emissions that affect human health. Diesel engine vehicles are highly acclaimed in Europe, due to the good fuel economy that diesel fuel offers. On the other hand, the "nitrogen oxides (NO_x)" and "particulate matter (PM)" contained in the exhaust gas must be greatly reduced to meet exhaust gas regulations, and technology is being actively developed for the sake of improved fuel economy and reduced exhaust gases.

(1) Demands on Diesel Vehicles

- Reduce exhaust gases (NO_x, PM, carbon monoxide (CO), hydrocarbon (HC) and smoke).
- Improve fuel economy.
- Reduce noise.
- Improve power output and driving performance.

(2) Transition of Exhaust Gas Regulations (Example of Large Vehicle Diesel Regulations)

- The EURO IV regulations take effect in Europe from 2005, and the 2004 MY regulations take effect in North America from 2004. Furthermore, the EURO V regulations will take effect in Europe from 2008, and the 2007 MY regulations will take effect in North America from 2007. Through these measures, PM and NO_x emissions are being reduced in stages.

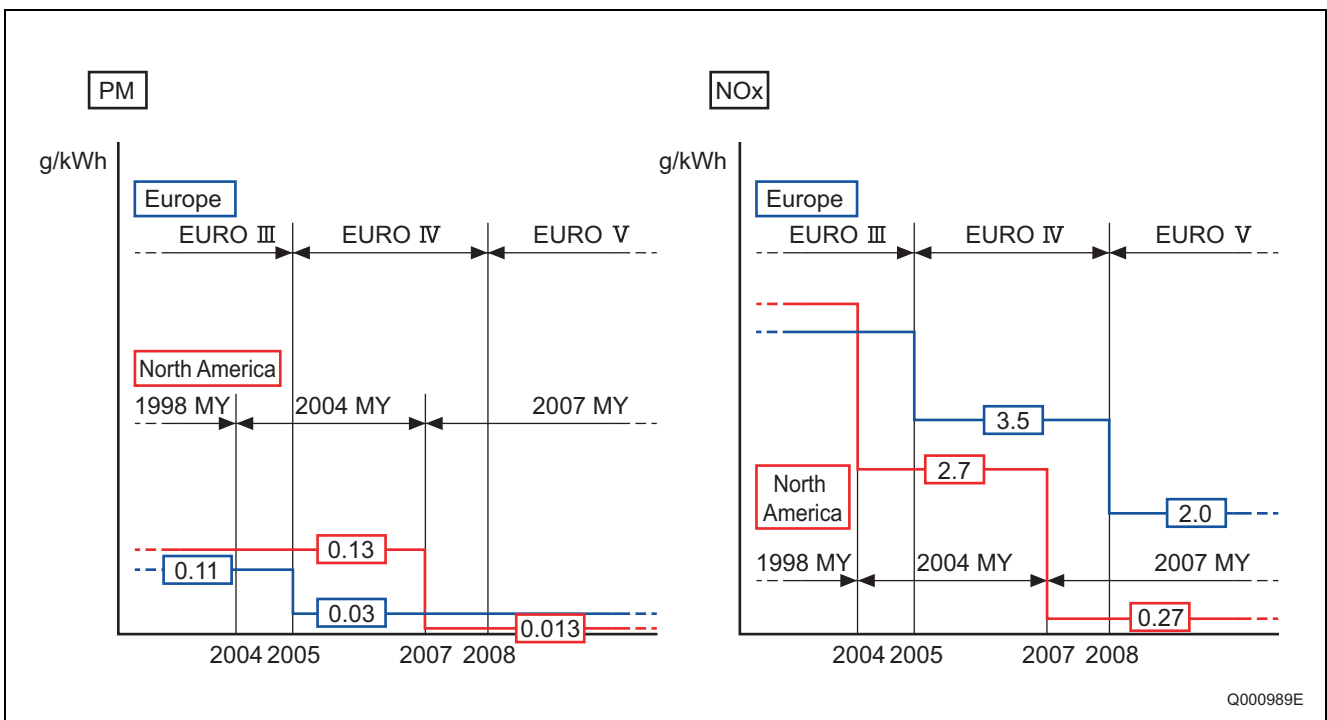

1.2 Demands On Fuel Injection System

- In order to address the various demands that are imposed on diesel vehicles, the fuel injection system (including the injection pump and nozzles) plays a significant role because it directly affects the performance of the engine and the vehicle. Some of the demands are: higher injection pressure, optimized injection rate, higher precision of injection timing control, and higher precision of injection quantity control.

< NOTE >

- For further information on higher injection pressure, optimized injection rate, higher precision of injection timing control, and higher precision of injection quantity control, see the material at the end of this document.
-

1.3 Types Of And Transitions In ECD (ELECTRONICALLY CONTROLLED DIESEL) Systems

- ECD systems include the ECD-V series (V3, V4, and V5) which implements electronic control through distributed pumps (VE type pumps), and common rail systems made up of a supply pump, rail, and injectors. Types are the ECD-V3 and V5 for passenger cars and RVs, the ECD-V4 that can also support small trucks, common rail systems for trucks, and common rail systems for passenger cars and RVs. In addition, there are 2nd-generation common rail systems that support both large vehicle and passenger car applications. The chart below shows the characteristics of these systems.

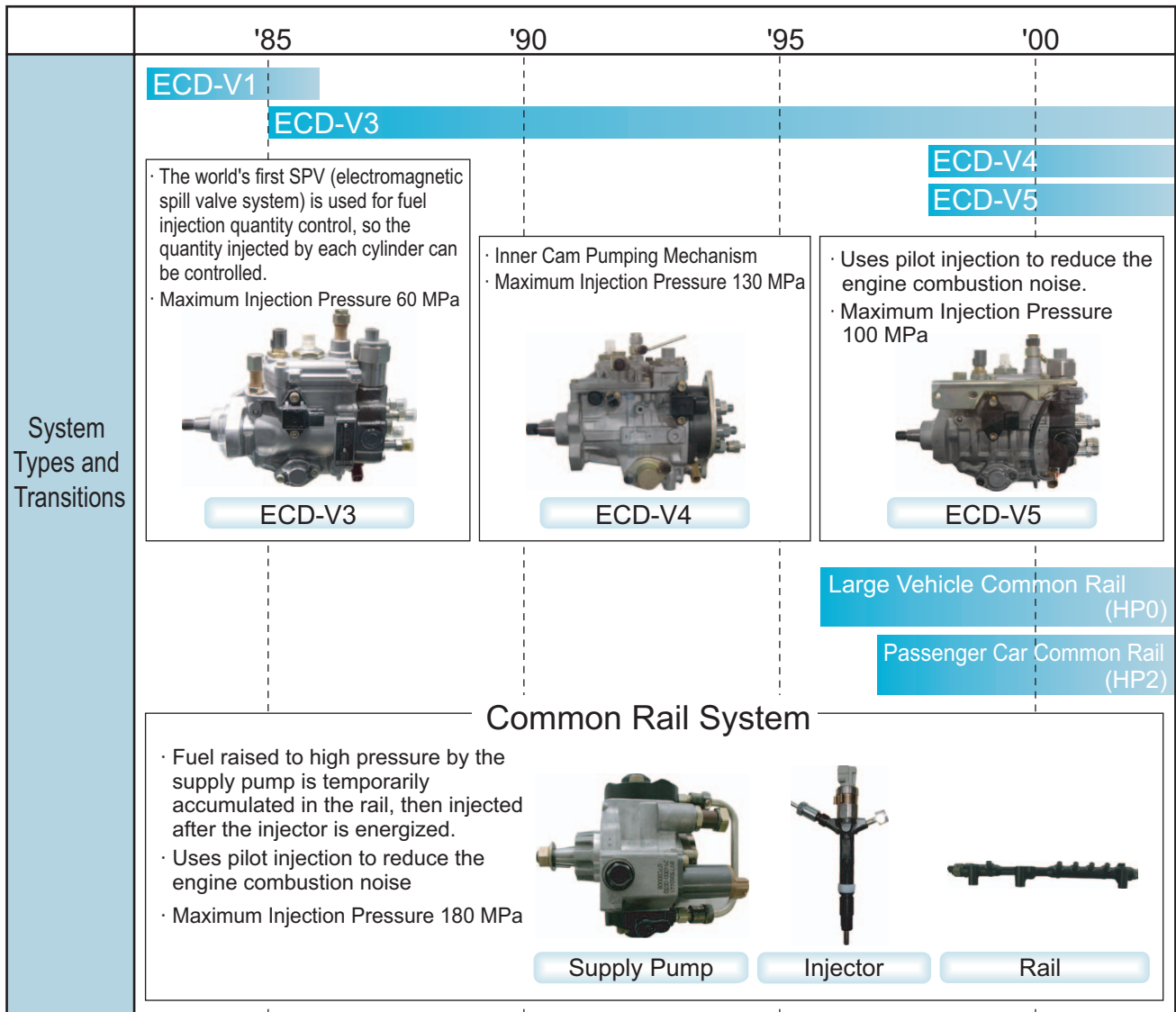

1.4 Common Rail System Characteristics

- The common rail system uses a type of accumulation chamber called a rail to store pressurized fuel, and injectors that contain electronically controlled solenoid valves to inject the pressurized fuel into the cylinders.
- Because the engine ECU controls the injection system (including the injection pressure, injection rate, and injection timing), the injection system is independent and thus unaffected by the engine speed or load.
- Because the engine ECU can control injection quantity and timing to a high level of precision, even multi-injection (multiple fuel injections in one injection stroke) is possible.
- This ensures a stable injection pressure at all times, even in the low engine speed range, and dramatically decreases the amount of black smoke ordinarily emitted by a diesel engine during start-up and acceleration. As a result, exhaust gas emissions are cleaner and reduced, and higher power output is achieved.

(1) Features of Injection Control

Injection Pressure Control

- Enables high-pressure injection even at low engine speeds.
- Optimizes control to minimize particulate matter and NOx emissions.

Injection Timing Control

- Enables finely tuned optimized control in accordance with driving conditions.

Injection Rate Control

- Pilot injection control injects a small amount of fuel before the main injection.

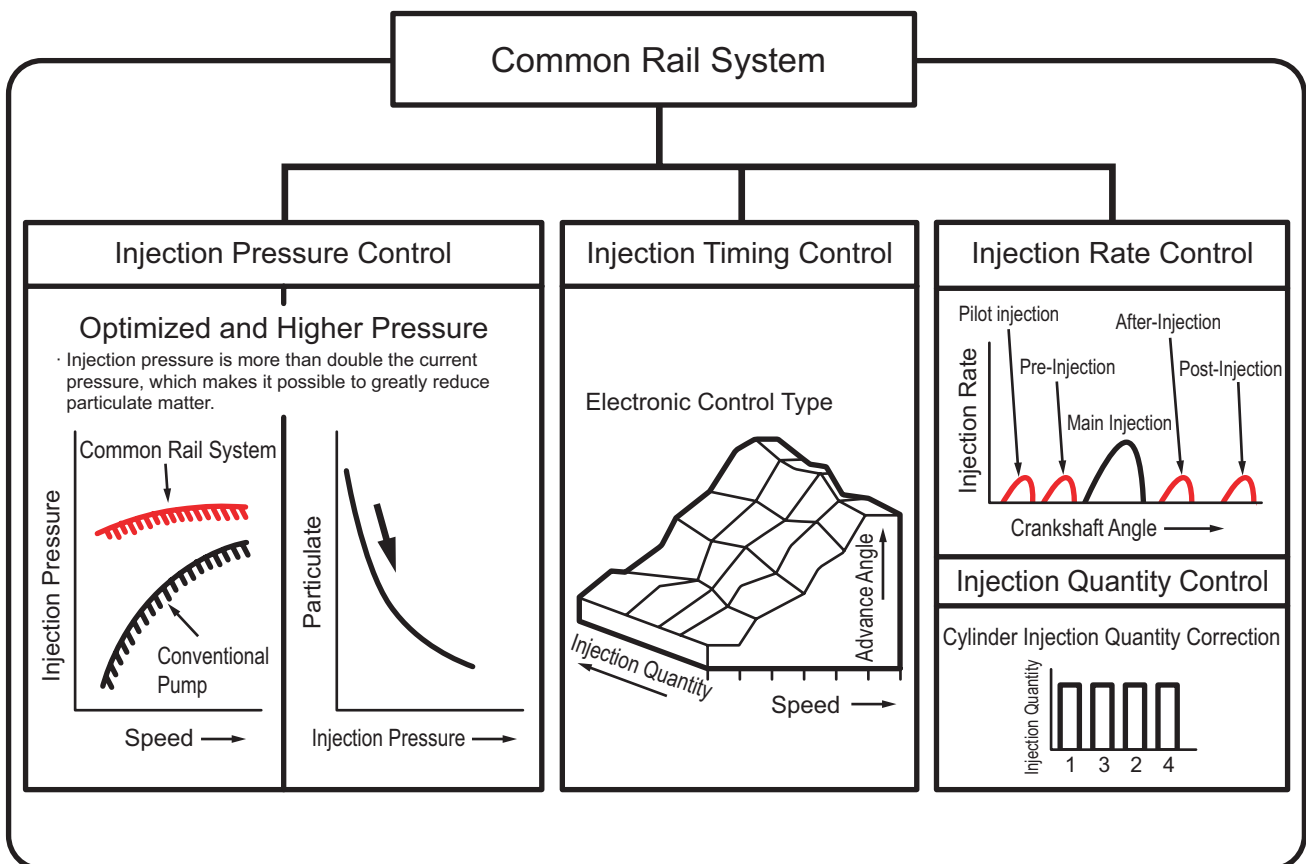

1.5 Common Rail System And Supply Pump Transitions

- The world's first common rail system for trucks was introduced in 1995. In 1999, the common rail system for passenger cars (the HP2 supply pump) was introduced, and then in 2001 a common rail system using the HP3 pump (a lighter and more compact supply pump) was introduced. In 2004, the three-cylinder HP4 based on the HP3 was introduced.

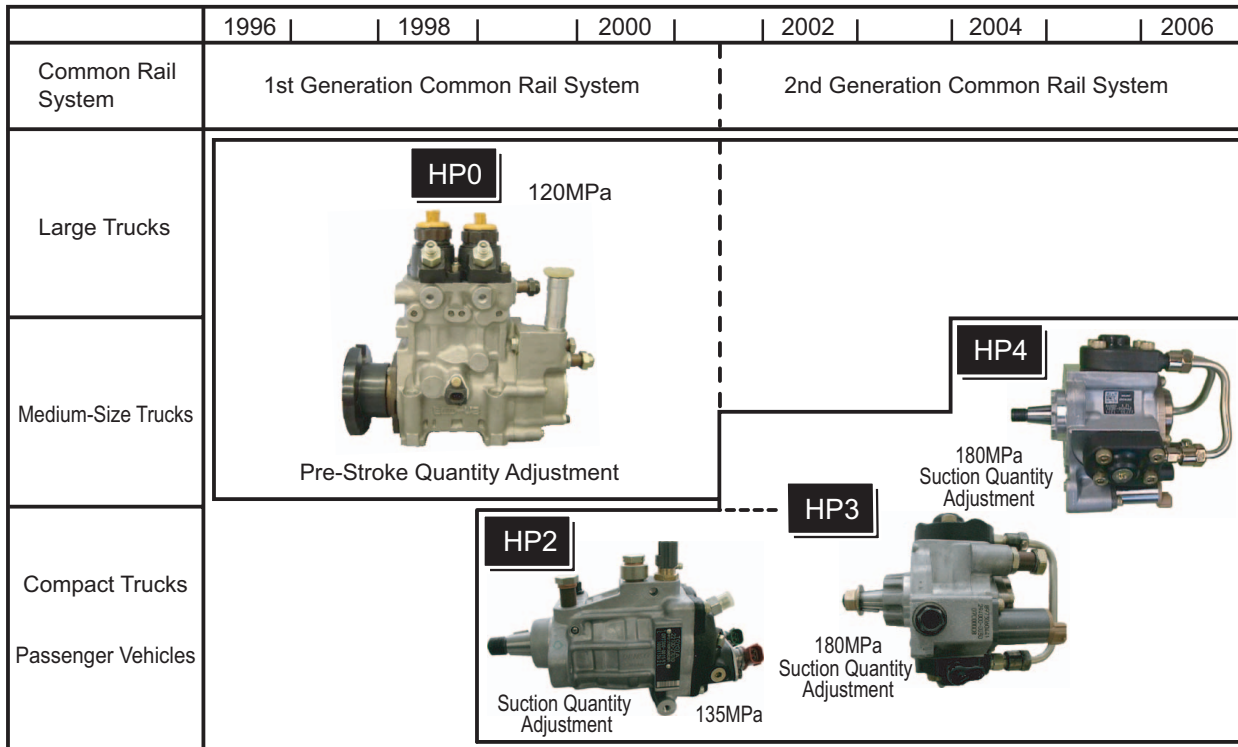

Q000752E

1.6 Injector Transitions

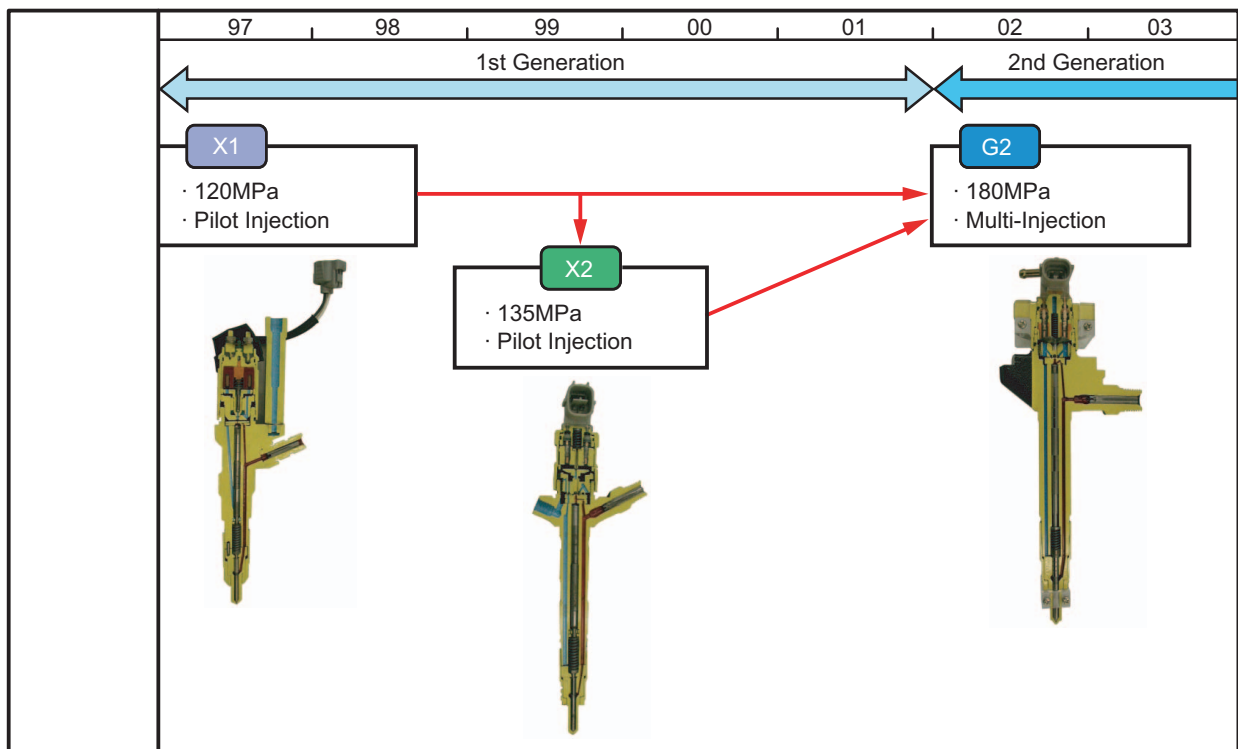

Q000753E

1.7 Common Rail System Configuration

- The common rail control system can be broadly divided into the following four areas: sensors, engine ECU, EDU, and actuators.

Sensors

- Detect the condition of the engine and the pump.

Engine ECU

- Receives signals from the sensors, calculates the proper injection quantity and injection timing for optimal engine operation, and sends the appropriate signals to the actuators.

EDU

- Enables the injectors to be actuated at high speeds. There are also types with charge circuits within the ECU that serve the same role as the EDU. In this case, there is no EDU.

Actuators

- Operate to provide optimal injection quantity and injection timing in accordance with the signals received from the engine ECU.

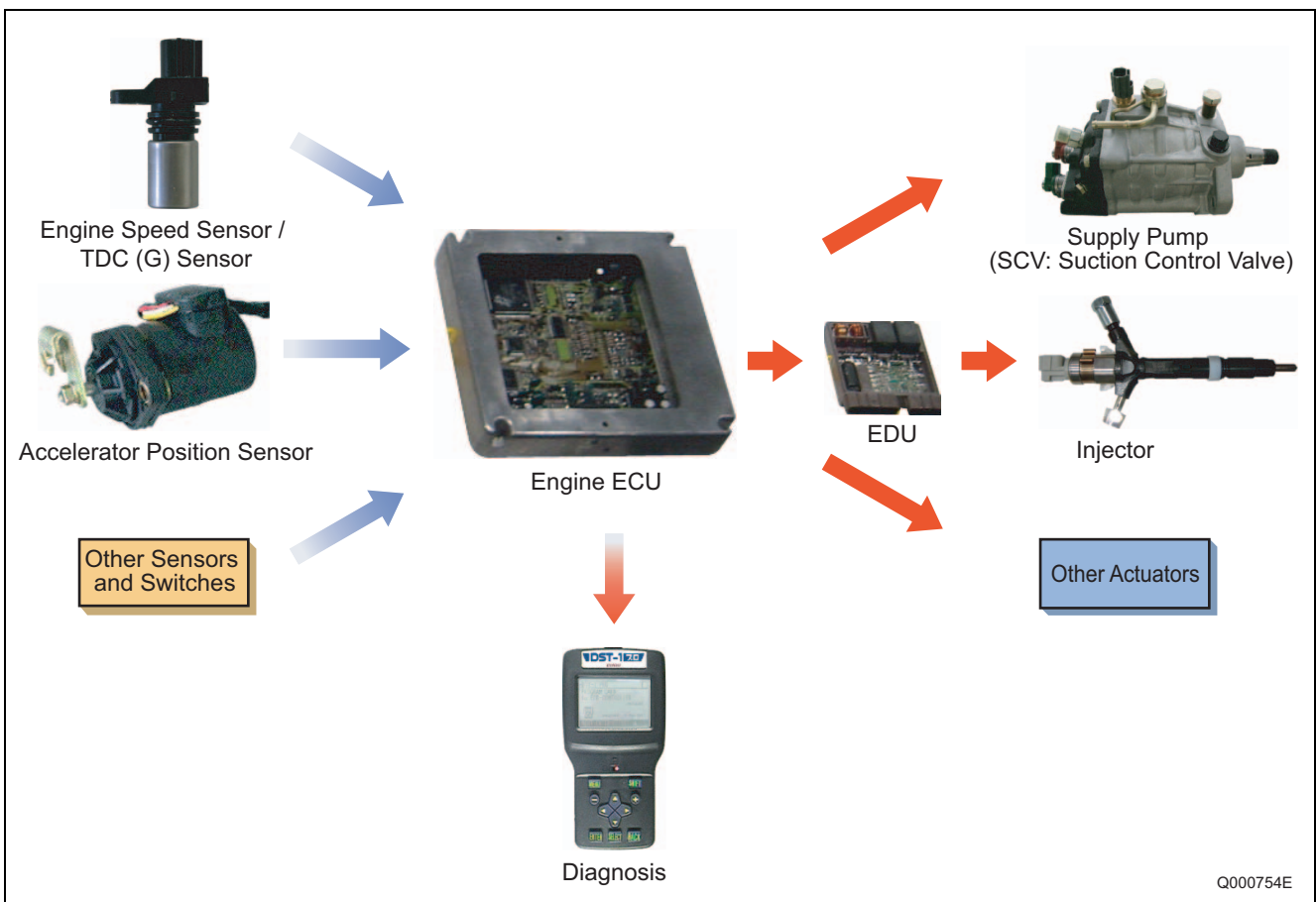

2. COMMON RAIL SYSTEM OUTLINE

2.1 Layout of Main Components

- Common rail systems are mainly made up of the supply pump, rail, and injectors. There are the following types according to the supply pump used.

(1) HP0 Type

- This system is the first common rail system that DENSO commercialized. It uses an HP0 type supply pump and is mounted in large trucks and large buses.

Exterior View of Main System Components

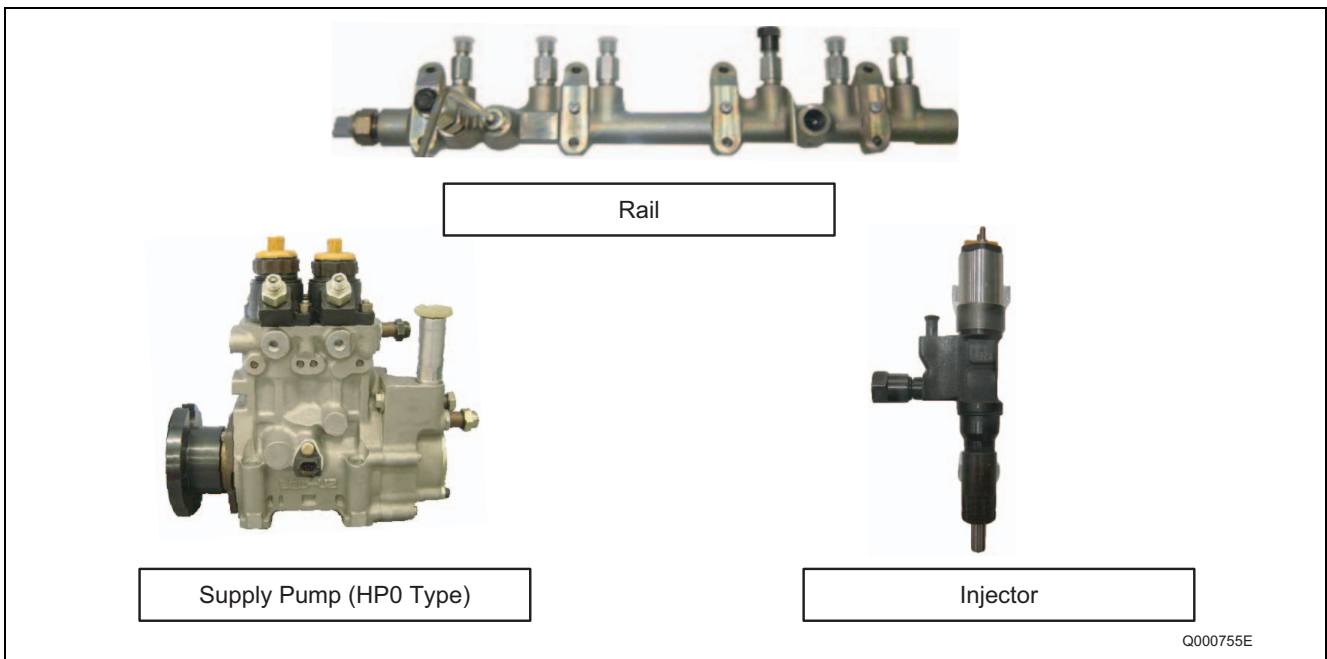

Configuration of Main System Components (Example of HP0)

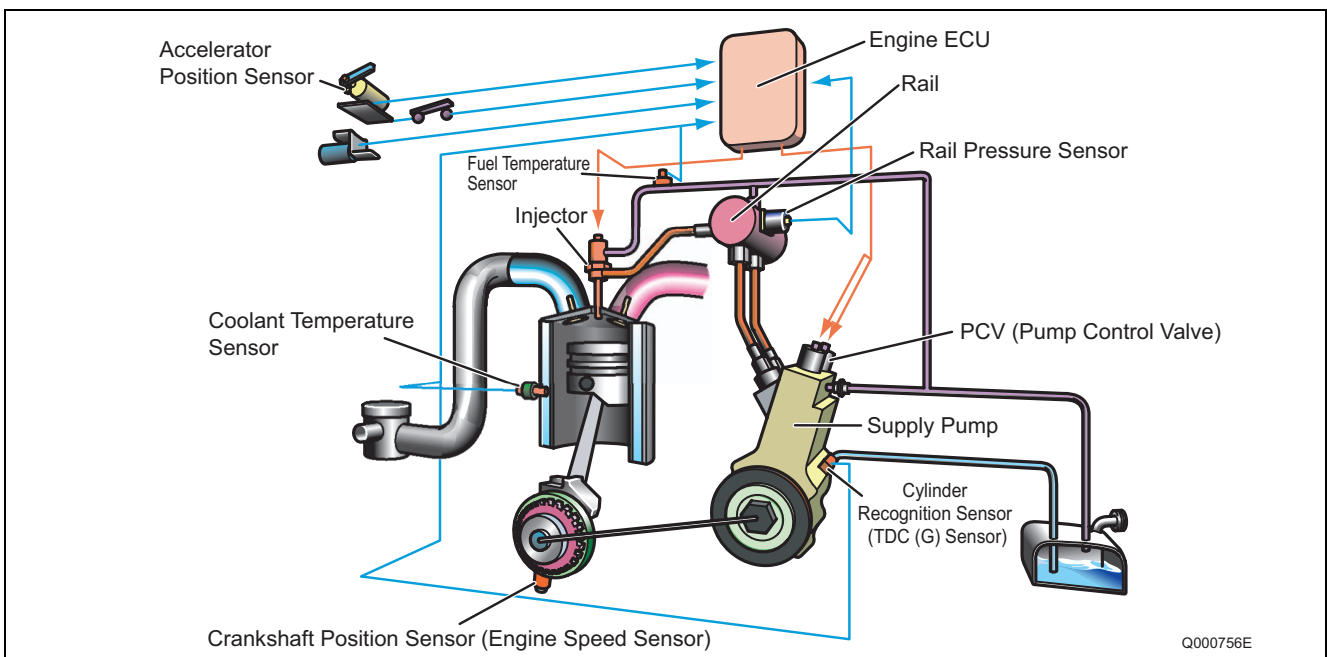

(2) HP2 Type

- This system uses a type of HP2 supply pump that has been made lighter and more compact, and is the common rail system for passenger cars and RVs instead of the ECD-V3.

Exterior View of Main System Components

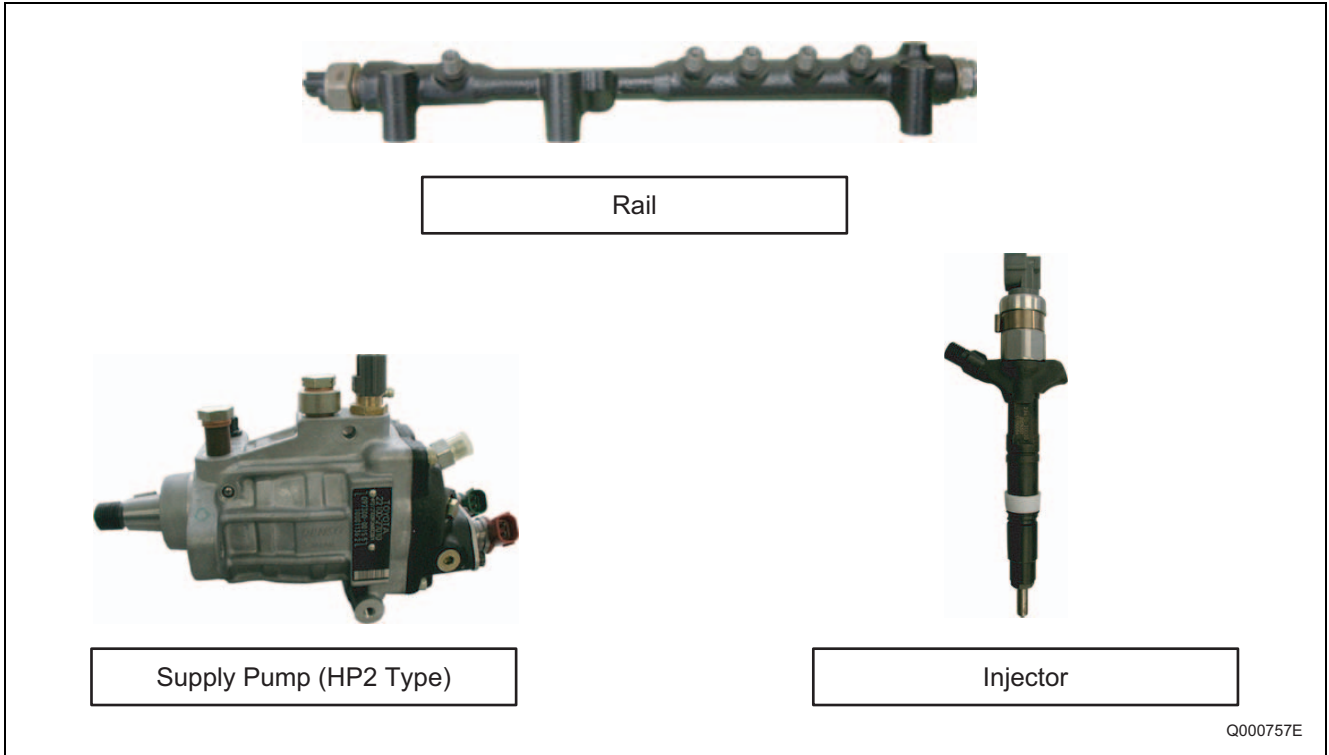

Mounting Diagram of Main System Components

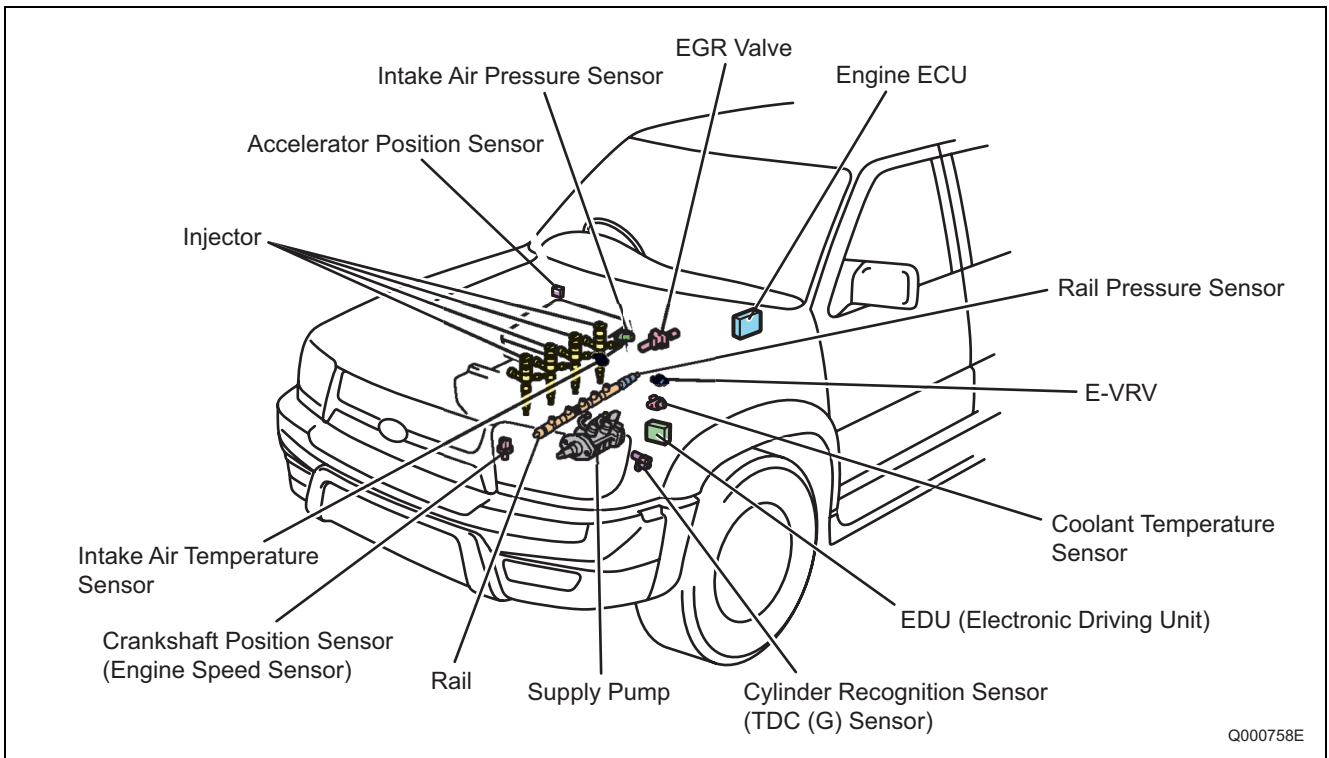

Overall System Flow (Fuel)

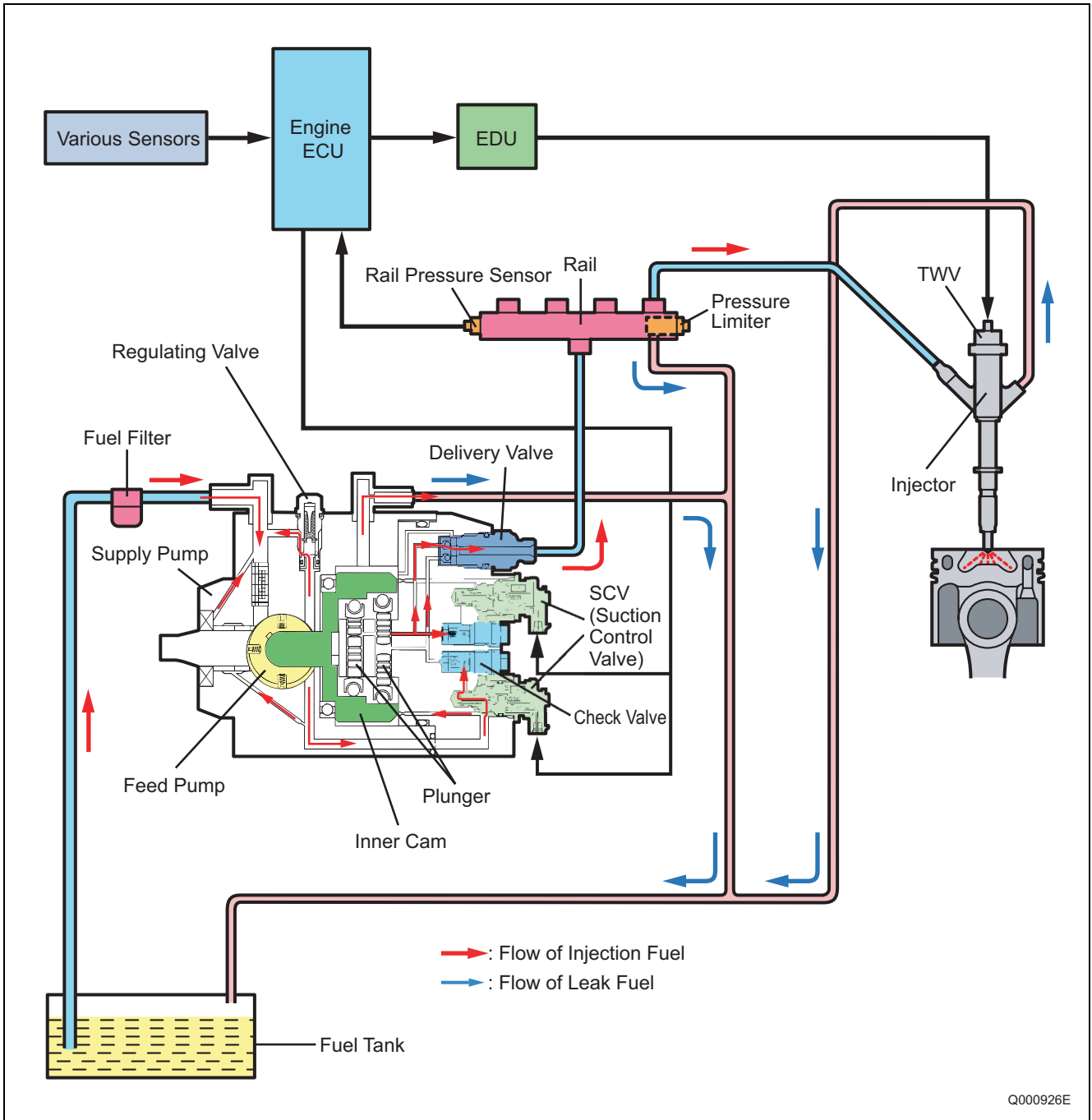

(3) HP3 Type, HP4 Type

HP3 Type

- This system uses an HP3 type supply pump that is compact, lightweight and provides higher pressure. It is mostly mounted in passenger cars and small trucks.

HP4 Type

- This system is basically the same as the HP3 type, however it uses the HP4 type supply pump, which has an increased pumping quantity to handle larger engines. This system is mostly mounted in medium-size trucks.

Exterior View of Main System Components

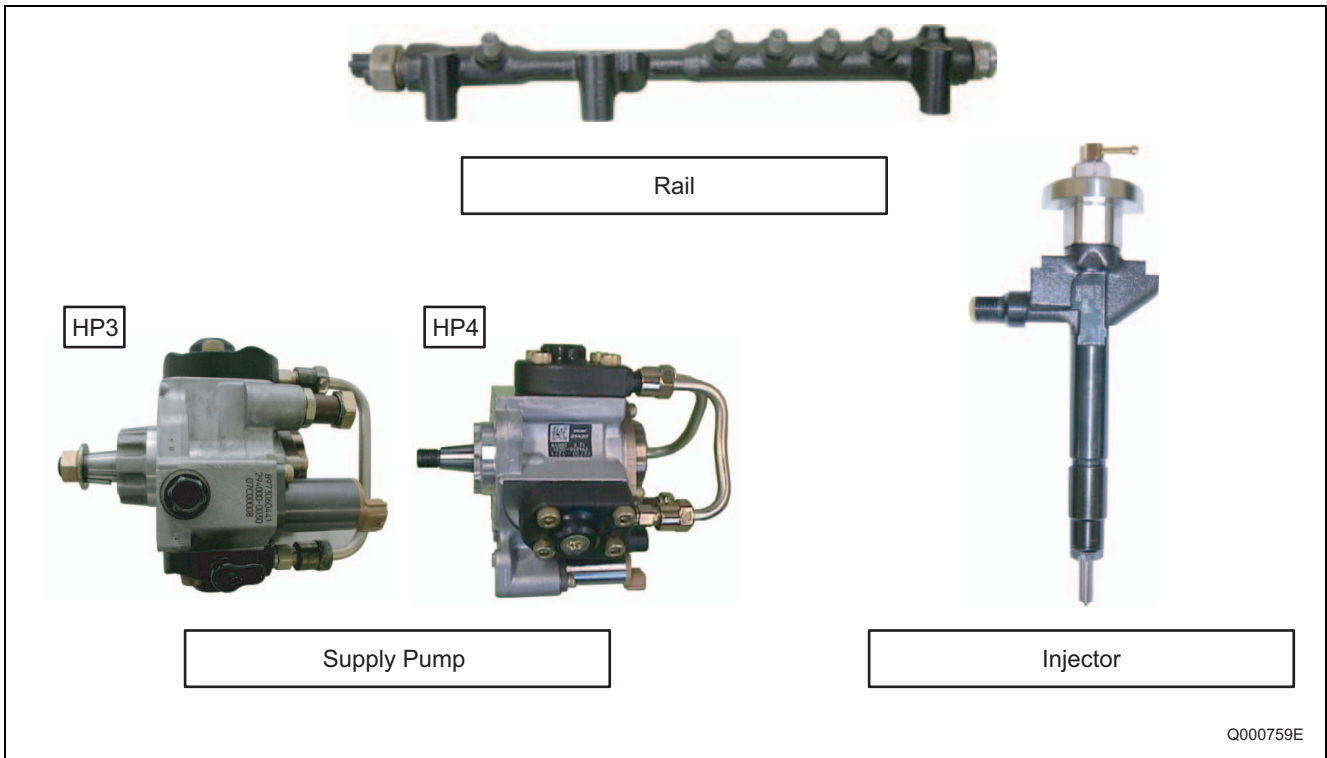

Mounting Diagram for Main System Components

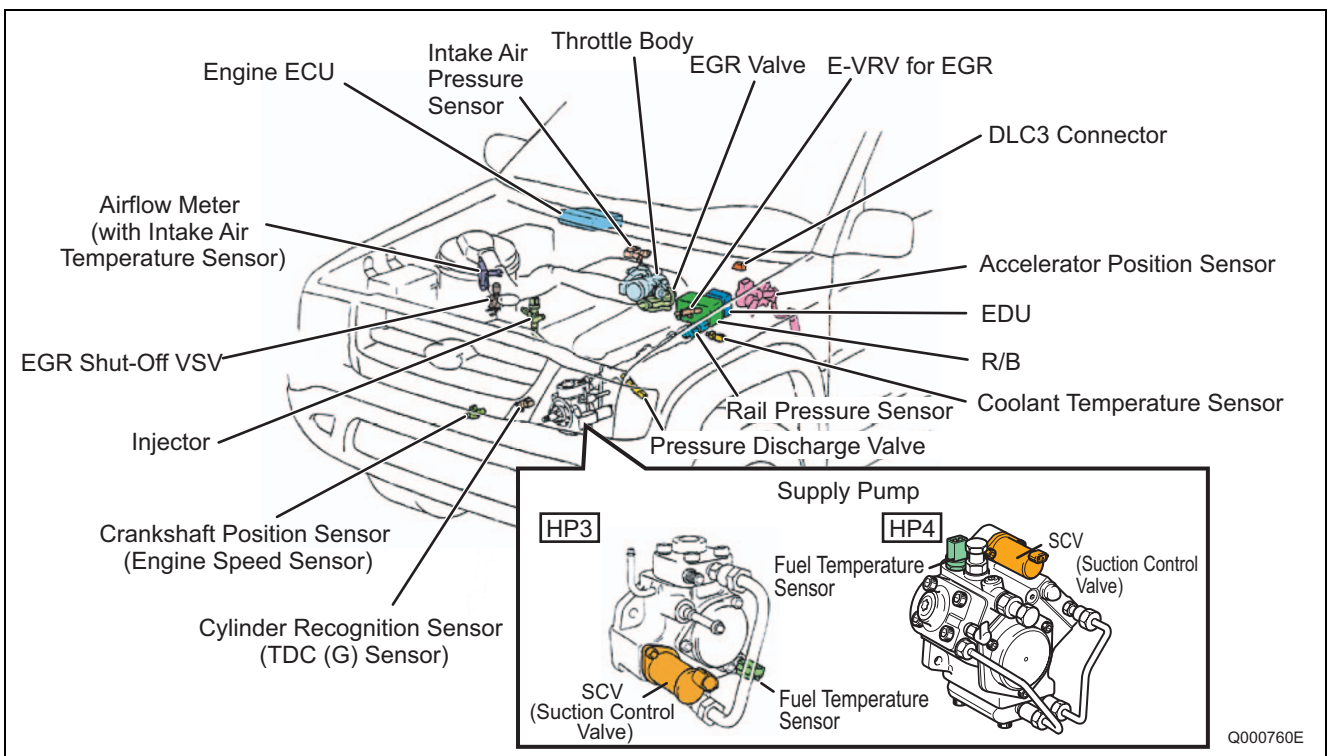

Overall System Flow (Fuel)

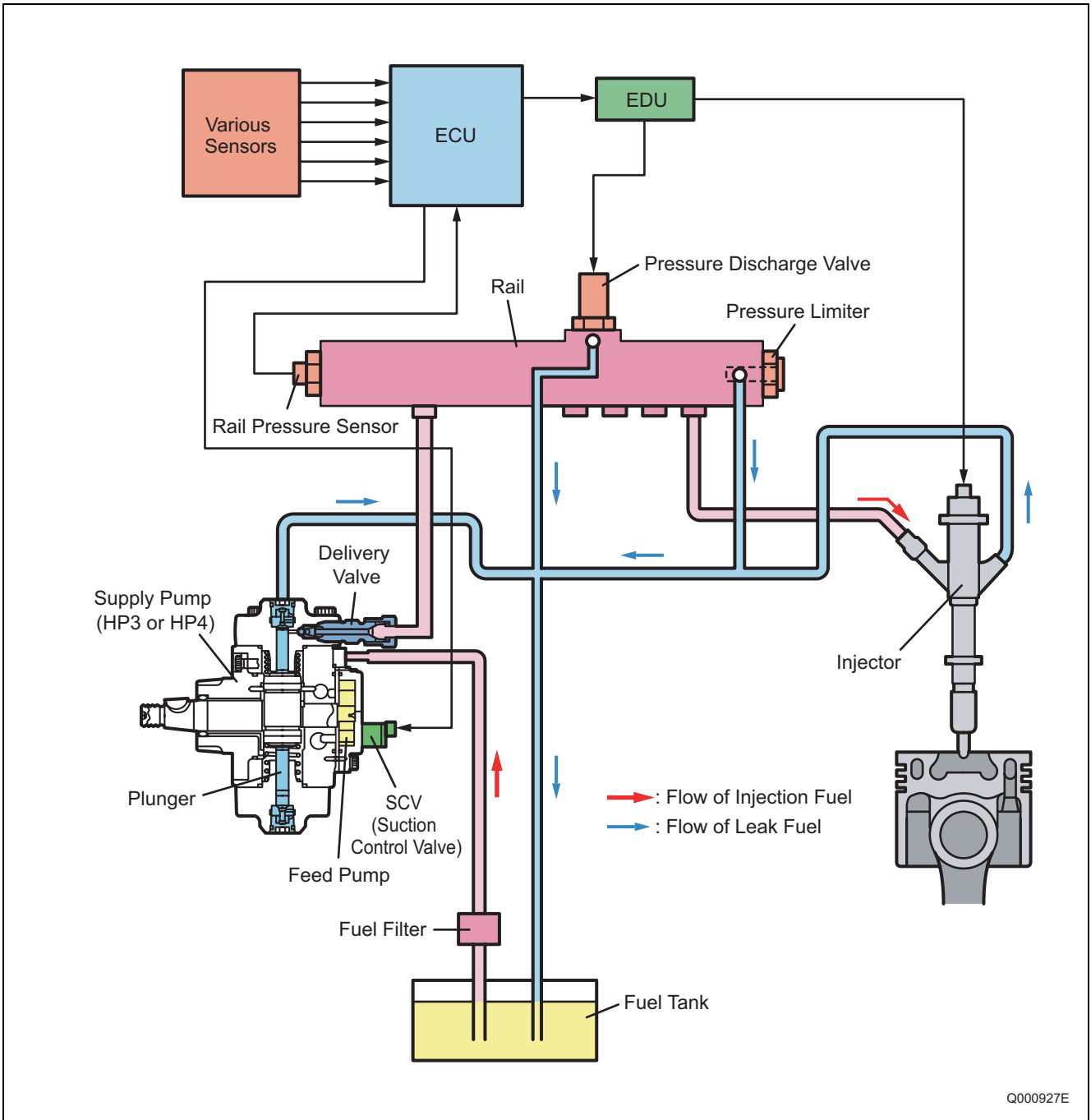

3. SUPPLY PUMP DESCRIPTION

3.1 HP0 Type

(1) Construction and Characteristics

- The HP0 supply pump is mainly made up of a pumping system as in conventional in-line pumps (two cylinders), the PCV (Pump Control Valve) for controlling the fuel discharge quantity, the cylinder recognition sensor {TDC (G) sensor}, and the feed pump.
- It supports the number of engine cylinders by changing the number of peaks on the cam. The supply pump rotates at half the speed of the engine. The relationship between the number of engine cylinders and the supply pump pumping is as shown in the table below.

Number of Engine Cylinders	Speed Ratio (Pump: Engine)	Supply Pump		Number of Pumping Rotations for 1 Cycle of the Engine (2 Rotations)
		Number of Cylinders	Cam Peaks	
4 Cylinders	1 : 2	2	2	4
6 Cylinders			3	6
8 Cylinders			4	8

- By increasing the number of cam peaks to handle the number of engine cylinders, a compact, two-cylinder pump unit is achieved. Furthermore, because this pump has the same number of pumping strokes as injections, it maintains a smooth and stable rail pressure.

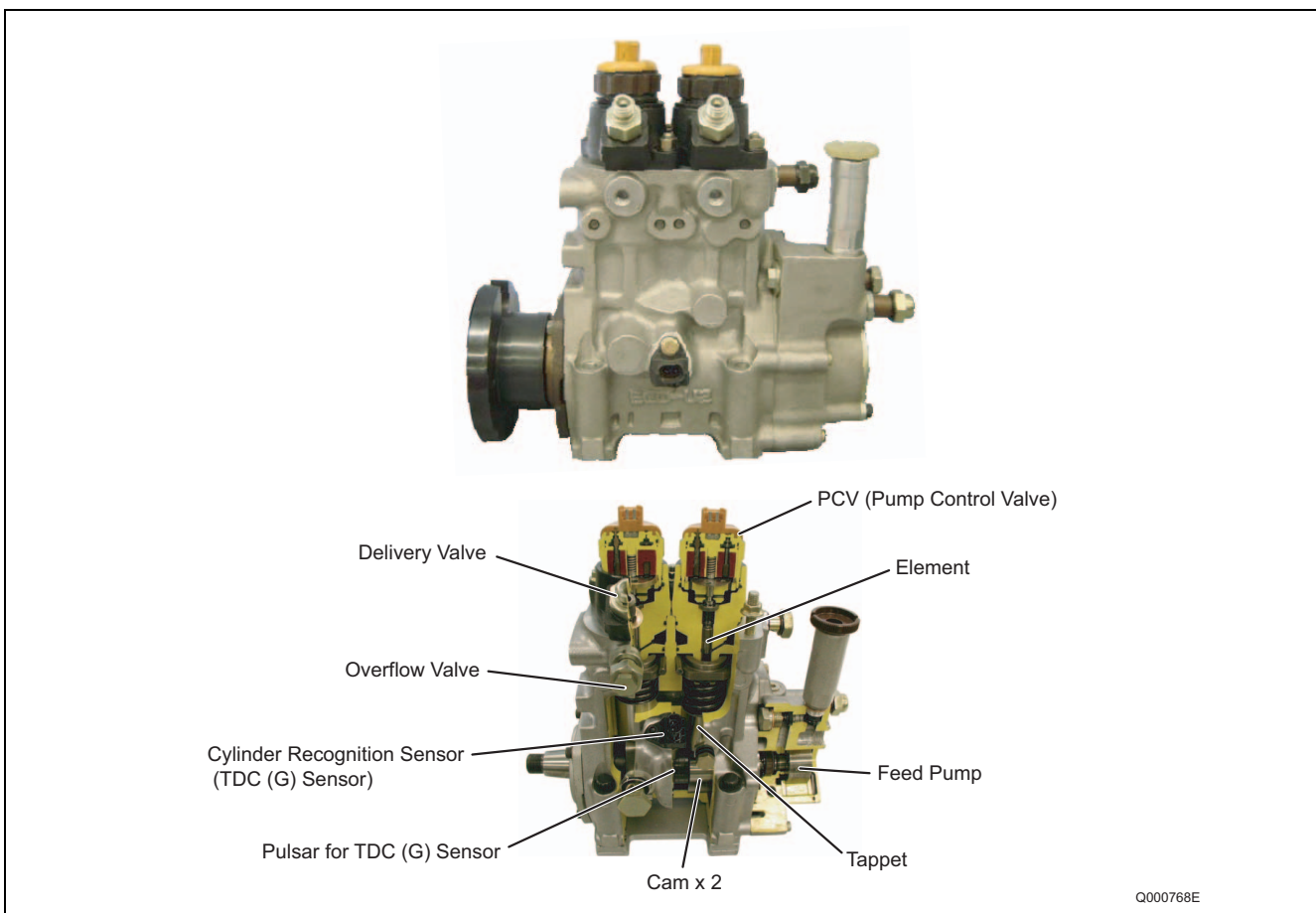

(2) Exploded View

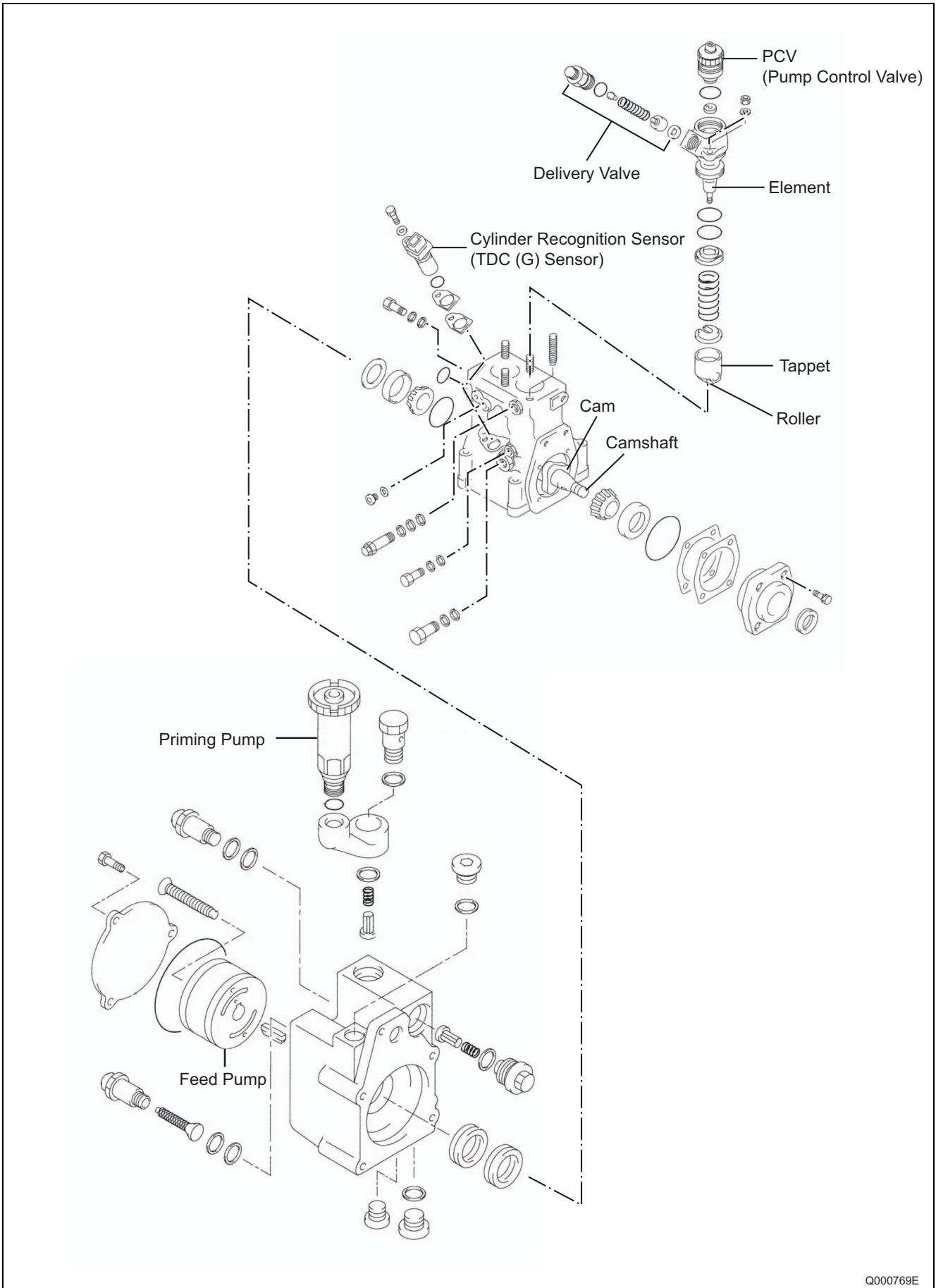

(3) Supply Pump Component Part Functions

Component Parts		Functions
Feed Pump		Draws fuel from the fuel tank and feeds it to the pumping mechanism.
Overflow Valve		Regulates the pressure of the fuel in the supply pump.
PCV (Pump Control Valve)		Controls the quantity of fuel delivered to the rail.
Pumping Mechanism	Cam	Actuates the tappet.
	Tappet	Transmits reciprocating motion to the plunger.
	Plunger	Moves reciprocally to draw and compress fuel.
Delivery Valve		Stops the reverse flow of fuel pumped to the rail.
Cylinder Recognition Sensor {TDC (G) Sensor}		Identifies the engine cylinders.

Feed Pump

- The feed pump, which is integrated in the supply pump, draws fuel from the fuel tank and feeds it to the pump chamber via the fuel filter. There are two types of feed pumps, the trochoid type and the vane type.

Trochoid Type

- The camshaft actuates the outer/inner rotors of the feed pump, causing them to start rotating. In accordance with the space produced by the movement of the outer/inner rotors, the feed pump draws fuel into the suction port and pumps fuel out the discharge port.

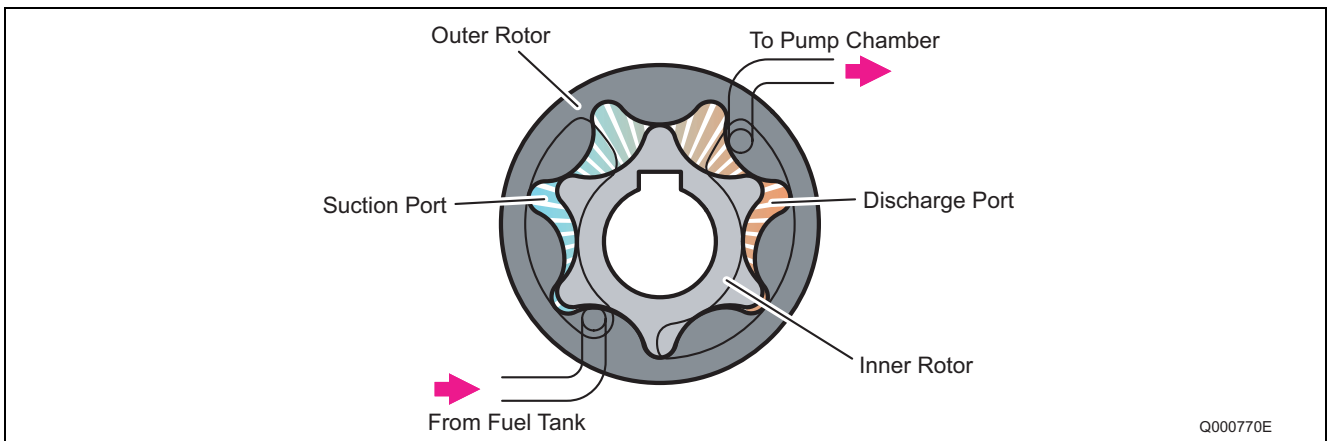

Vane Type

- The camshaft actuates the feed pump rotor and the vanes slide along the inner circumference of the eccentric ring. Along with the rotation of the rotor, the pump draws fuel from the fuel tank, and discharges it to the SCV and the pumping mechanism.

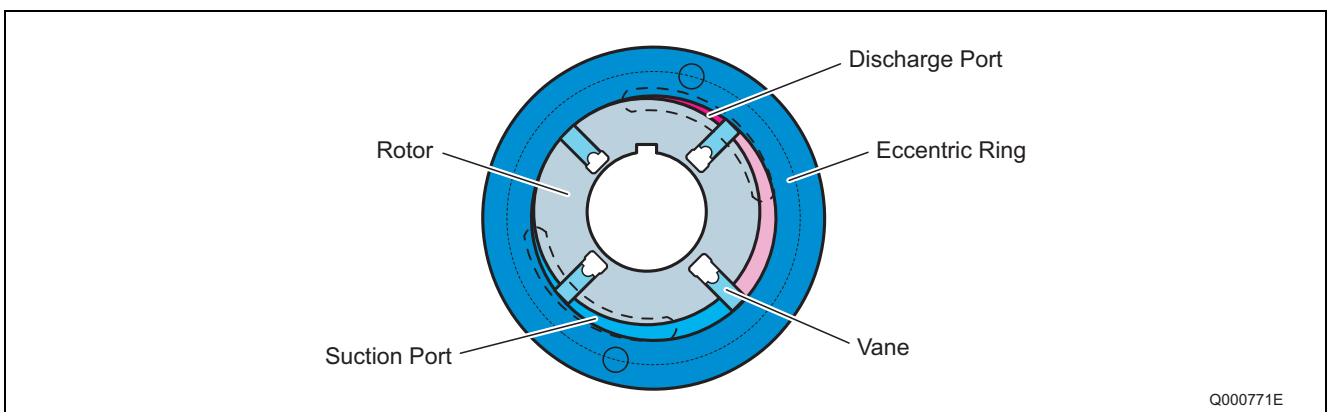

PCV: Pump Control Valve

- The PCV (Pump Control Valve) regulates the fuel discharge quantity from the supply pump in order to regulate the rail pressure. The fuel quantity discharged from the supply pump to the rail is determined by the timing with which the current is applied to the PCV.

Actuation Circuit

- The diagram below shows the actuation circuit of the PCV. The ignition switch turns the PCV relay ON and OFF to apply current to the PCV. The ECU handles ON/OFF control of the PCV. Based on the signals from each sensor, it determines the target discharge quantity required to provide optimum rail pressure and controls the ON/OFF timing for the PCV to achieve this target discharge quantity.

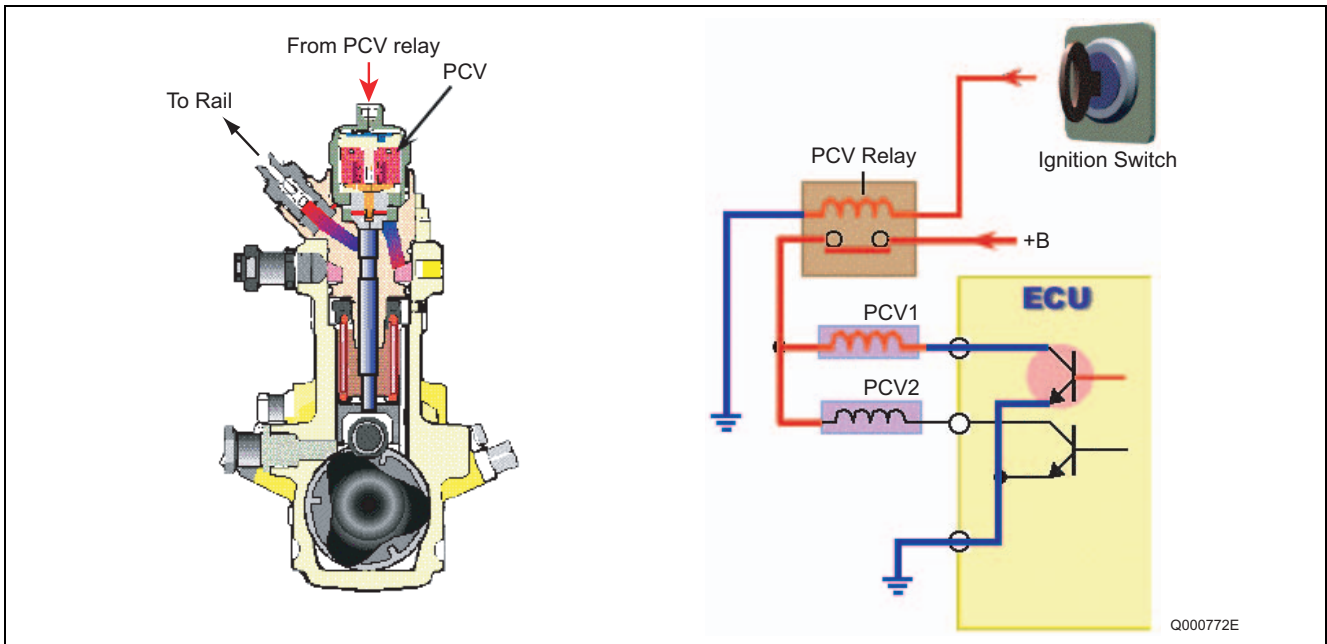

Pumping Mechanism

- The camshaft is actuated by the engine and the cam actuates the plunger via the tappet to pump the fuel sent by the feed pump. The PCV controls the discharge quantity. The fuel is pumped from the feed pump to the cylinder, and then to the delivery valve.

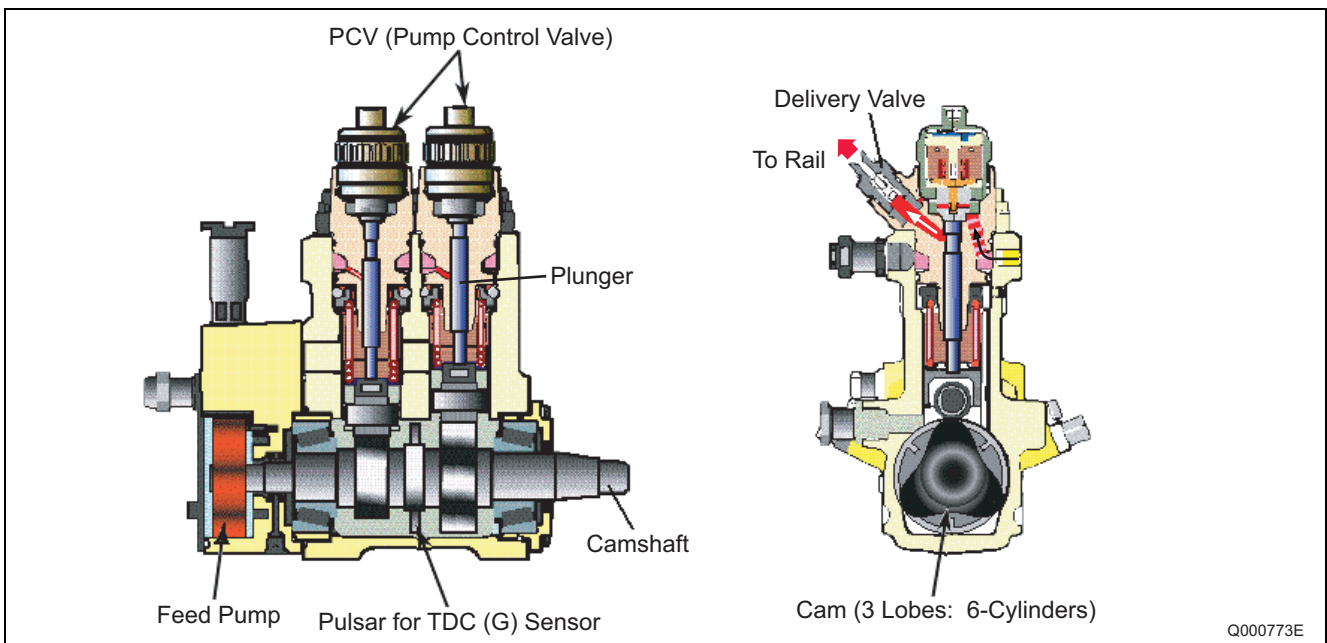

CYLINDER RECOGNITION SENSOR {TDC (G) SENSOR}

- The cylinder recognition sensor {TDC (G) sensor} uses the alternating current voltage generated by the change in the lines of magnetic force passing through the coil to send the output voltage to the ECU. This is the same for the engine speed sensor installed on the engine side. A disc-shaped gear, which is provided in the center of the supply pump camshaft, has cutouts that are placed at 120° intervals, plus an extra cutout. Therefore, this gear outputs seven pulses for every two revolutions of the engine (for a six-cylinder engine). Through the combination of engine-side engine speed pulses and TDC pulses, the pulse after the extra cutout pulse is recognized as the No. 1 cylinder.

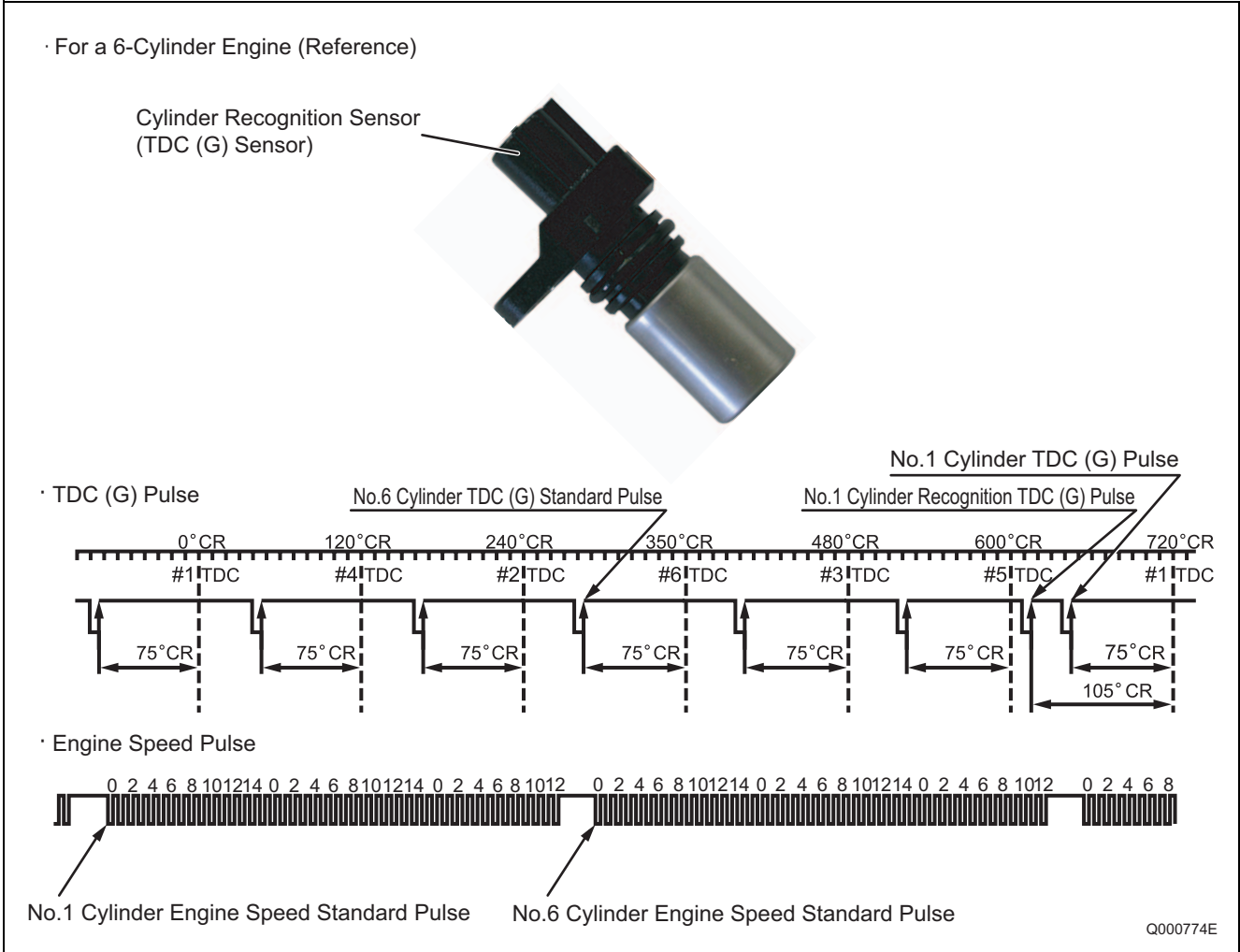

(4) Supply Pump Operation

Supply Pump Overall Fuel Flow

- The fuel is drawn by the feed pump from the fuel tank and sent to the pumping mechanism via the PCV. The PCV adjusts the quantity of fuel pumped by the pumping mechanism to the necessary discharge quantity, and the fuel is pumped to the rail via the delivery valve.

Fuel Discharge Quantity Control

- The fuel sent from the feed pump is pumped by the plunger. In order to adjust the rail pressure, the PCV controls the discharge quantity. Actual operation is as follows.

PCV and Plunger Operation During Each Stroke

Intake Stroke (A)	In the plunger's descent stroke, the PCV opens and low-pressure fuel is suctioned into the plunger chamber via the PCV.
Pre-Stroke (B)	Even when the plunger enters its ascent stroke, the PCV remains open while it is not energized. During this time, fuel drawn in through the PCV is returned through the PCV without being pressurized (pre-stroke).
Pumping Stroke (C)	At a timing suited to the required discharge quantity, power is supplied to close the PCV, the return passage closes, and pressure in the plunger chamber rises. Therefore, the fuel passes through the delivery valve (reverse cut-off valve) and is pumped to the rail. Specifically, the plunger lift portion after the PCV closes becomes the discharge quantity, and by varying the timing for the PCV closing (the end point of the plunger pre-stroke), the discharge quantity is varied to control the rail pressure.
Intake Stroke (A)	When the cam exceeds the maximum lift, the plunger enters its descent stroke and pressure in the plunger chamber decreases. At this time, the delivery valve closes and fuel pumping stops. In addition, the PCV opens because it is de-energized, and low-pressure fuel is suctioned into the plunger chamber. Specifically, the system goes into state A.

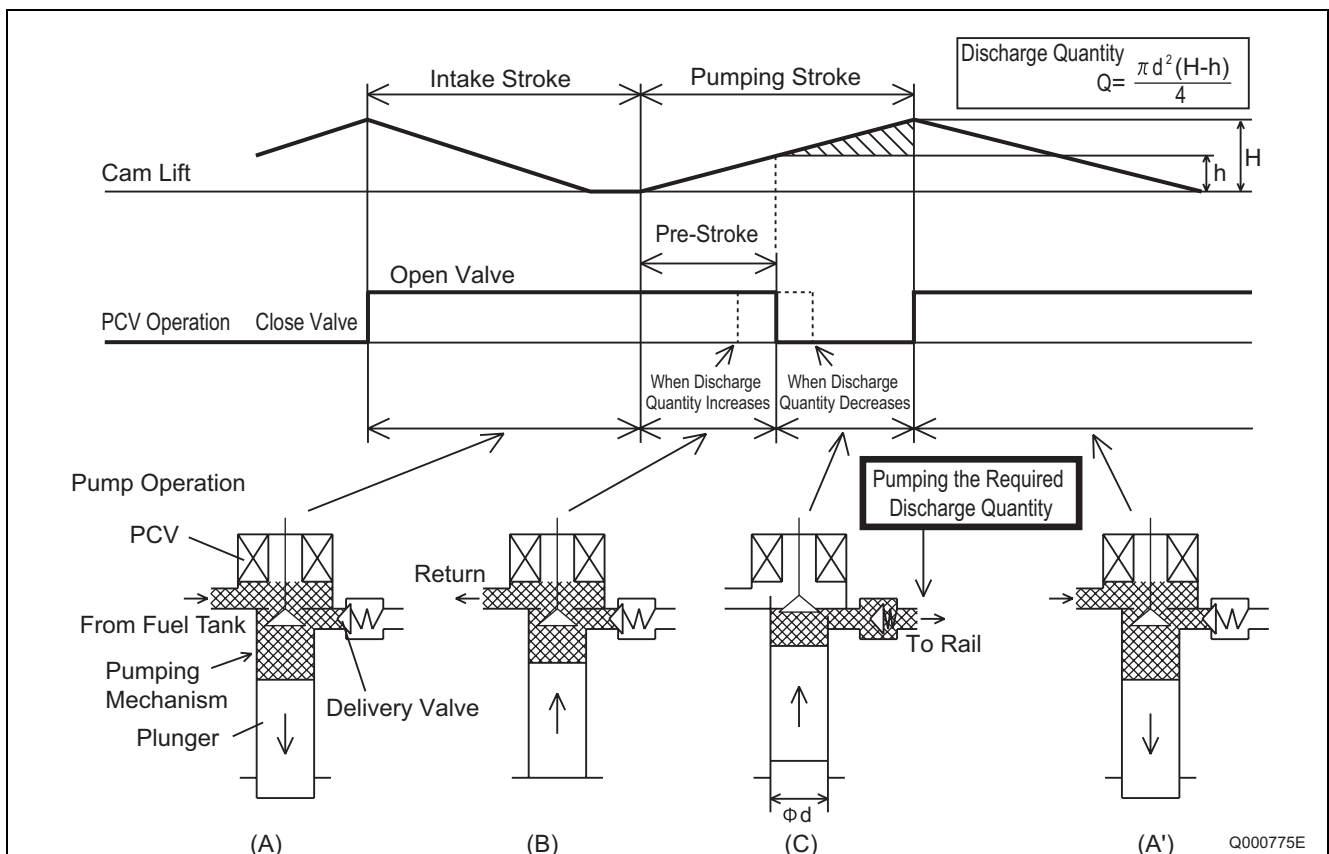

3.2 HP2 Type

(1) Construction and Characteristics

- The supply pump is primarily composed of the two pumping mechanism (inner cam, roller, two plungers) systems, the SCV (Suction Control Valve), the fuel temperature sensor, and the feed pump (vane type), and is actuated with half the engine rotation.
- The pumping mechanism consists of an inner cam and a plunger, and forms a tandem configuration in which two systems are arranged axially. This makes the supply pump compact and reduces the peak torque.
- The quantity of fuel discharged to the rail is controlled by the fuel suction quantity using SCV (Suction Control Valve) control. In order to control the discharge quantity with the suction quantity, excess pumping operations are eliminated, reducing the actuation load and suppressing the rise in fuel temperature.

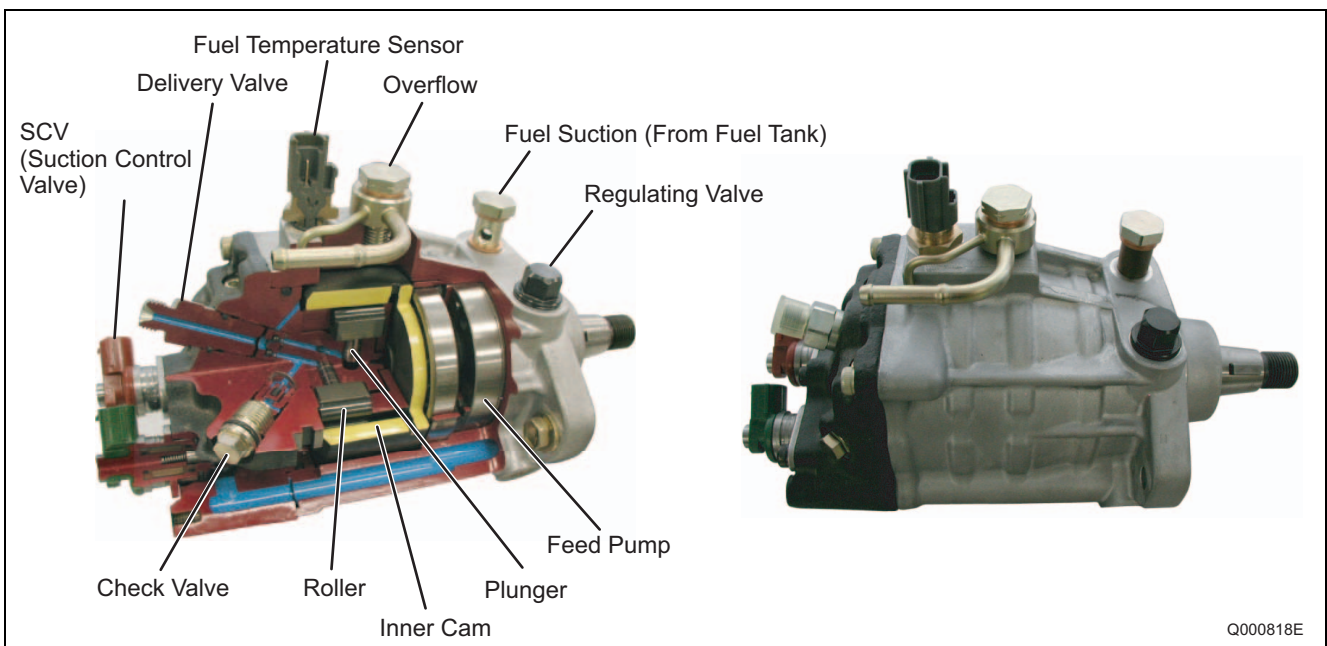

(2) Supply Pump Actuating Torque

- Because the pumping mechanism is a tandem configuration, its peak actuating torque is one-half that of a single pump with the same discharge capacity.

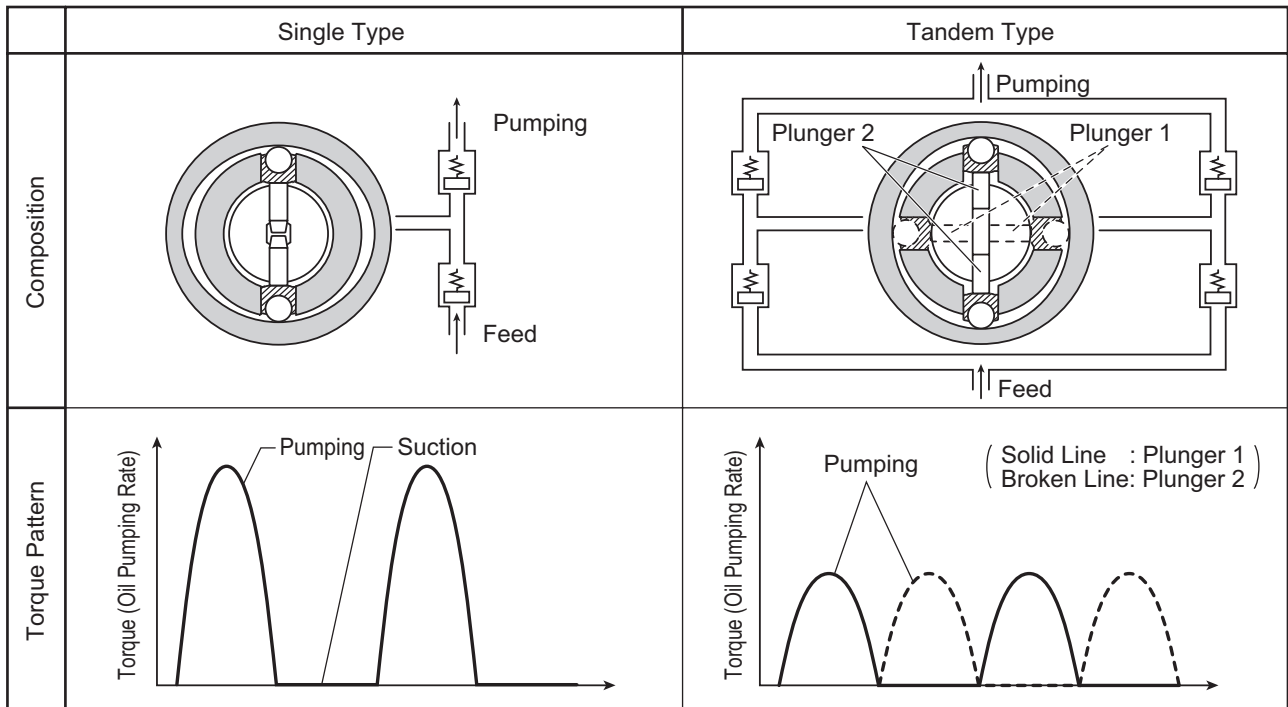

Q000819E

(3) Exploded View

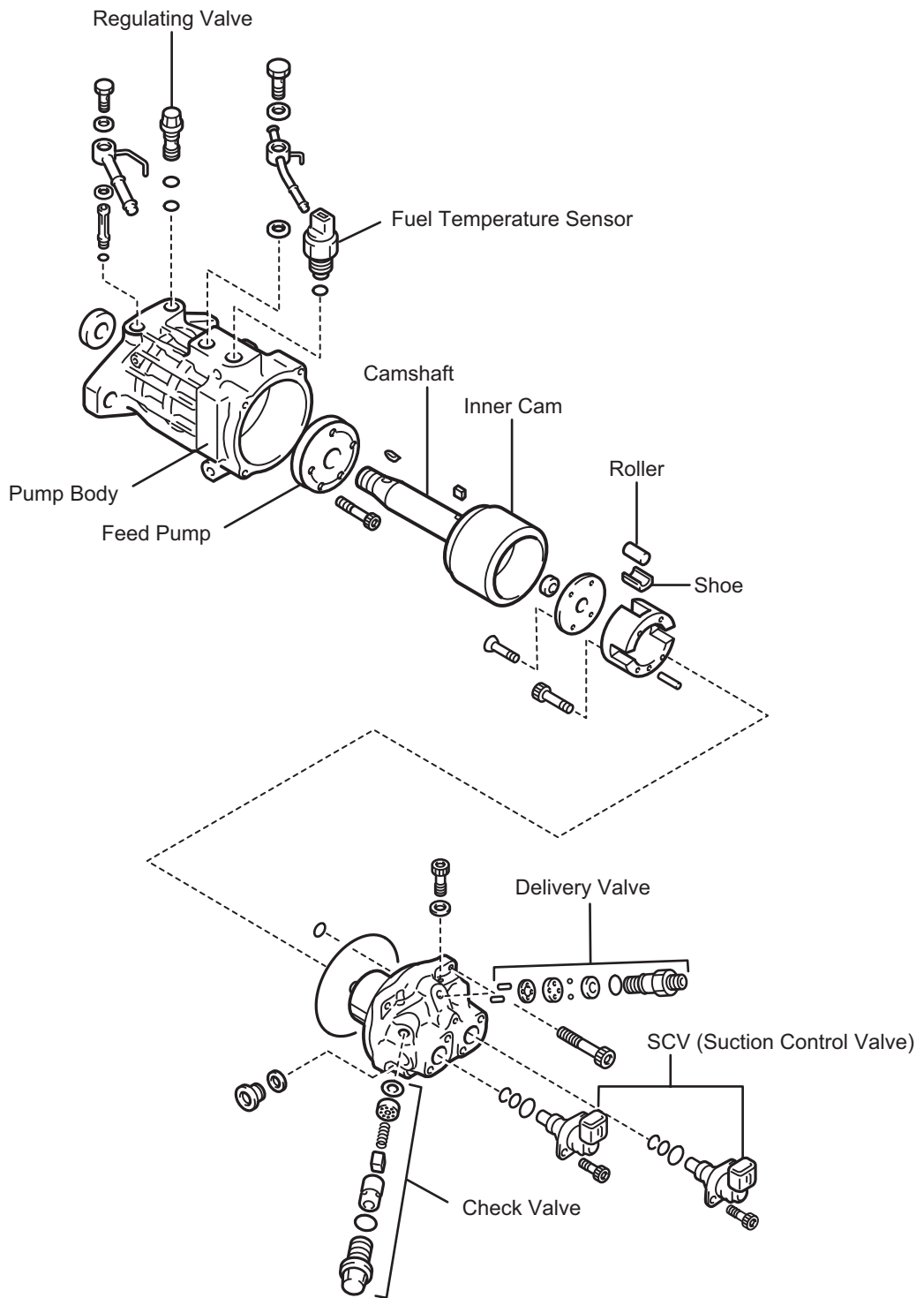

(4) Component Part Functions

Component Parts		Functions
Feed Pump		Draws fuel from the fuel tank and feeds it to the pumping mechanism.
Regulating Valve		Regulates internal fuel pressure in the supply pump.
SCV (Suction Control Valve)		Controls the quantity of fuel that is fed to the plunger in order to control fuel pressure in the rail.
Pumping Mechanism	Inner Cam	Actuates the plunger.
	Roller	Actuates the plunger.
	Plunger	Moves reciprocally to draw and compress fuel.
Delivery Valve		Maintains high pressure by separating the pressurized area (rail) from the pumping mechanism.
Fuel Temperature Sensor		Detects the fuel temperature.
Check Valve		Prevents the pressurized fuel in the pumping mechanism from flowing back into the suction side.

Feed Pump

- The feed pump is a four-vaned type that draws fuel from the fuel tank and discharges it to the pumping mechanism. The rotation of the drive shaft causes the feed pump rotor to rotate and the vane to move by sliding along the inner surface of the casing (eccentric ring). Along with the rotation of the rotor, the pump draws fuel from the fuel tank, and discharges it to the SCV and the pumping mechanism. To keep the vane pressed against the inner circumference, a spring is provided inside each vane, in order to minimize fuel leakage within the pump.

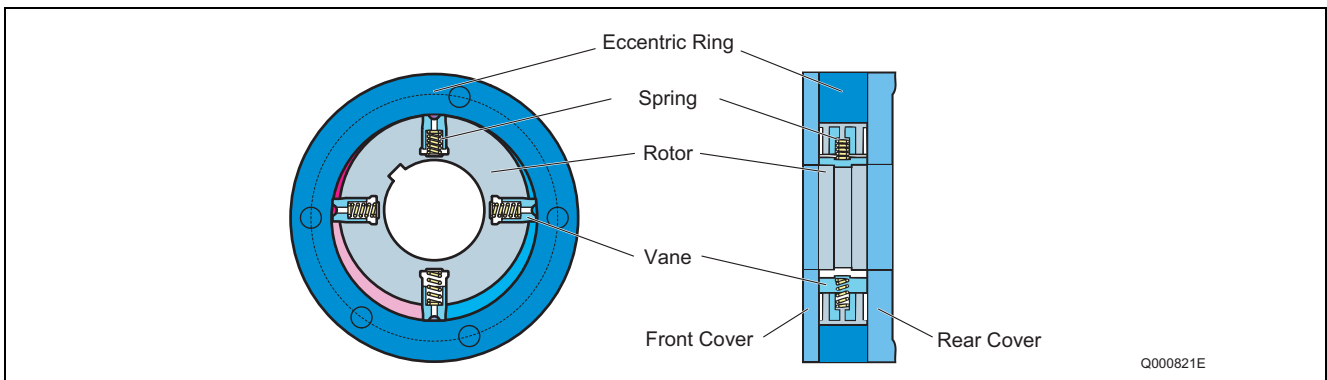

Regulating Valve

- The purpose of the regulating valve is to control the feed pressure (fuel pumping pressure) sending fuel to the pumping mechanism. As the rotational movement of the pump increases and the feed pressure exceeds the pressure set at the regulating valve, the valve opens by overcoming the spring force, allowing the fuel to return to the suction side.

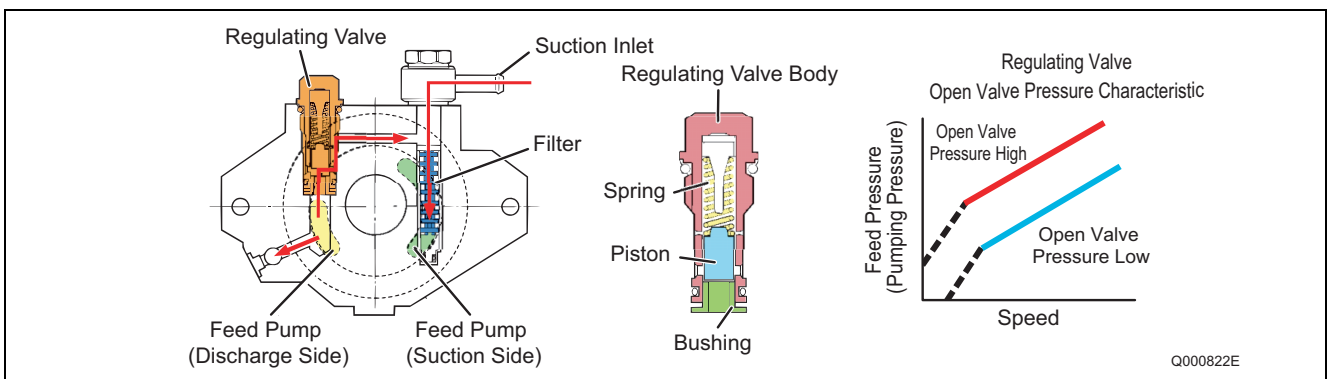

SCV: Suction Control Valve

- A solenoid type valve has been adopted. The ECU controls the duration of the current applied to the SCV in order to control the quantity of fuel drawn into the pumping mechanism. Because only the quantity of fuel required to achieve the target rail pressure is drawn in, the actuating load of the supply pump decreases, thus improving fuel economy.

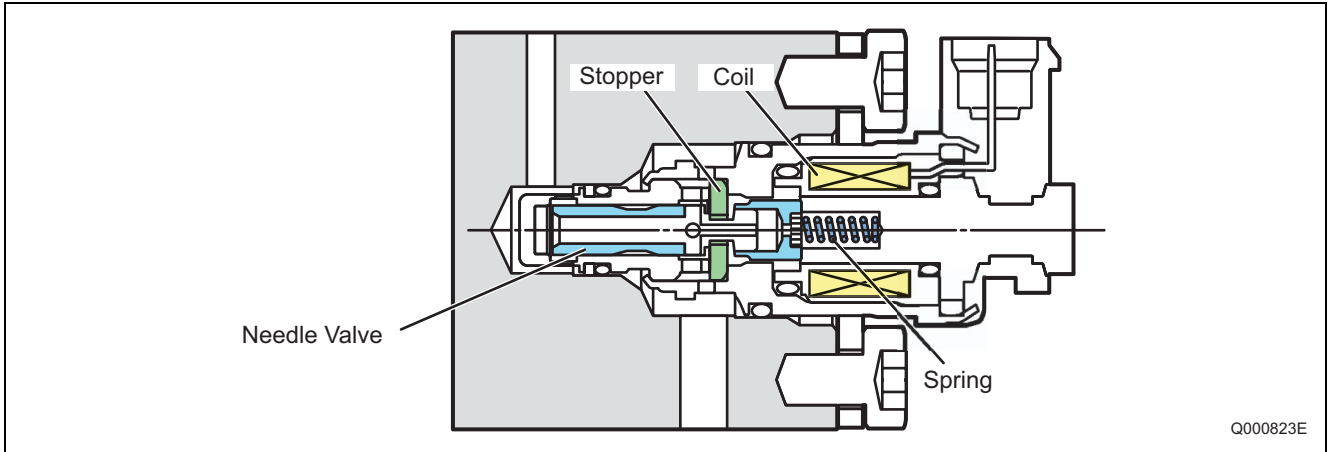
**SCV ON**

- When current is applied to the coil, it pulls the needle valve upward, allowing fuel to be drawn into the pumping mechanism of the supply pump.

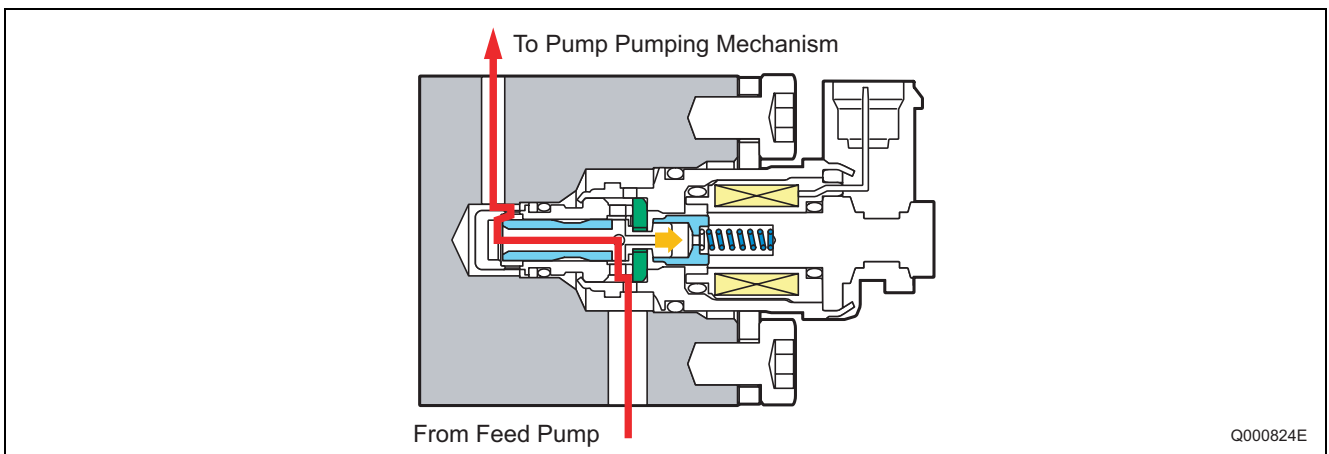
**SCV OFF**

- When current is no longer applied to the coil, the needle valve closes and stops the suction of fuel.

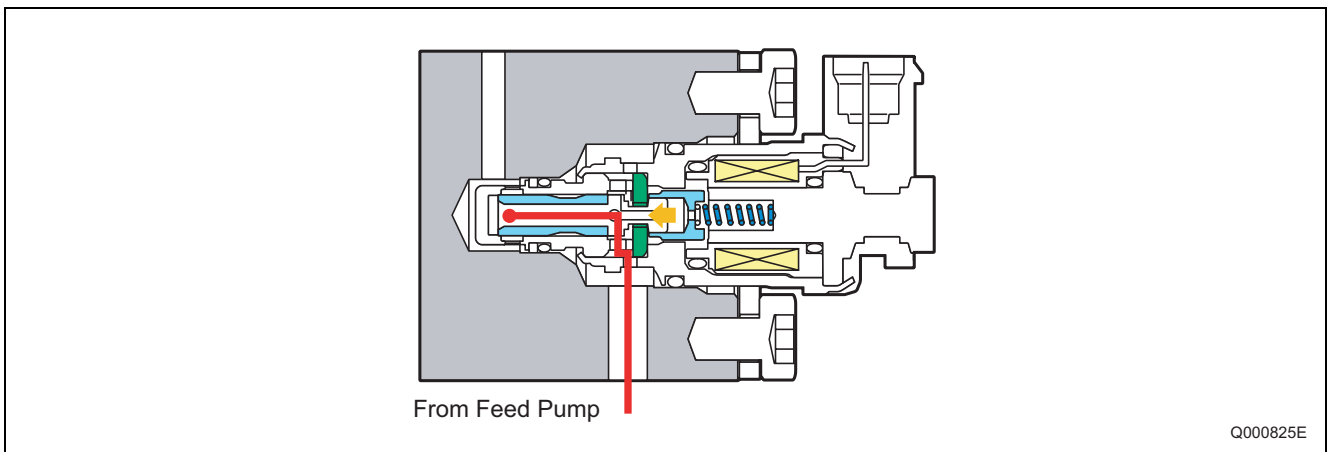

Pumping Mechanism (Plunger, Inner Cam, Roller)

- The pumping mechanism is made up of the plunger, inner cam, and roller, and it draws in the fuel discharged by the feed pump and pumps it to the rail. Because the drive shaft and the inner cam have an integral construction, the rotation of the drive shaft directly becomes the rotation of the inner cam.
- Two plunger systems are arranged in series (tandem type) inside the inner cam. Plunger 1 is situated horizontally, and plunger 2 is situated vertically. Plunger 1 and plunger 2 have their suction and compression strokes reversed (when one is on the intake, the other is discharging), and each plunger discharges twice for each one rotation, so for one rotation of the supply pump, they discharge a total of four times to the rail.

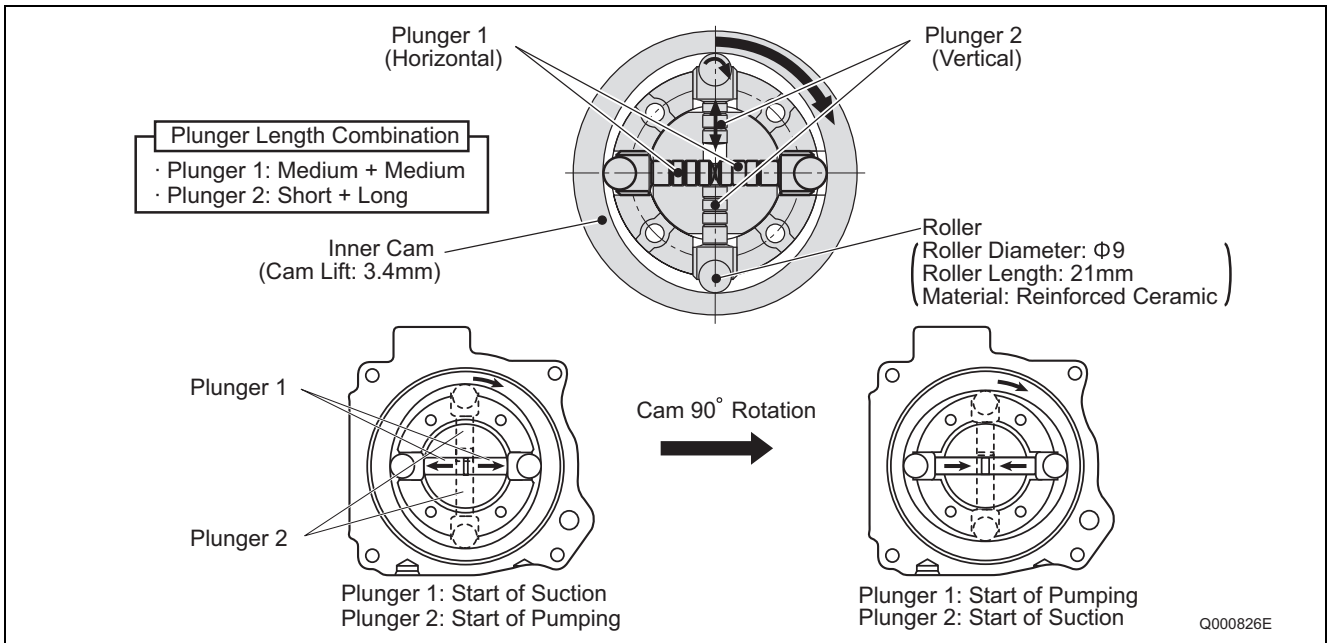

Delivery Valve

- The delivery valve, which contains two valve balls, delivers the pressurized fuel from plungers 1 and 2 to the rail in alternating strokes. When the pressure in the plunger exceeds the pressure in the rail, the valve opens to discharge fuel.

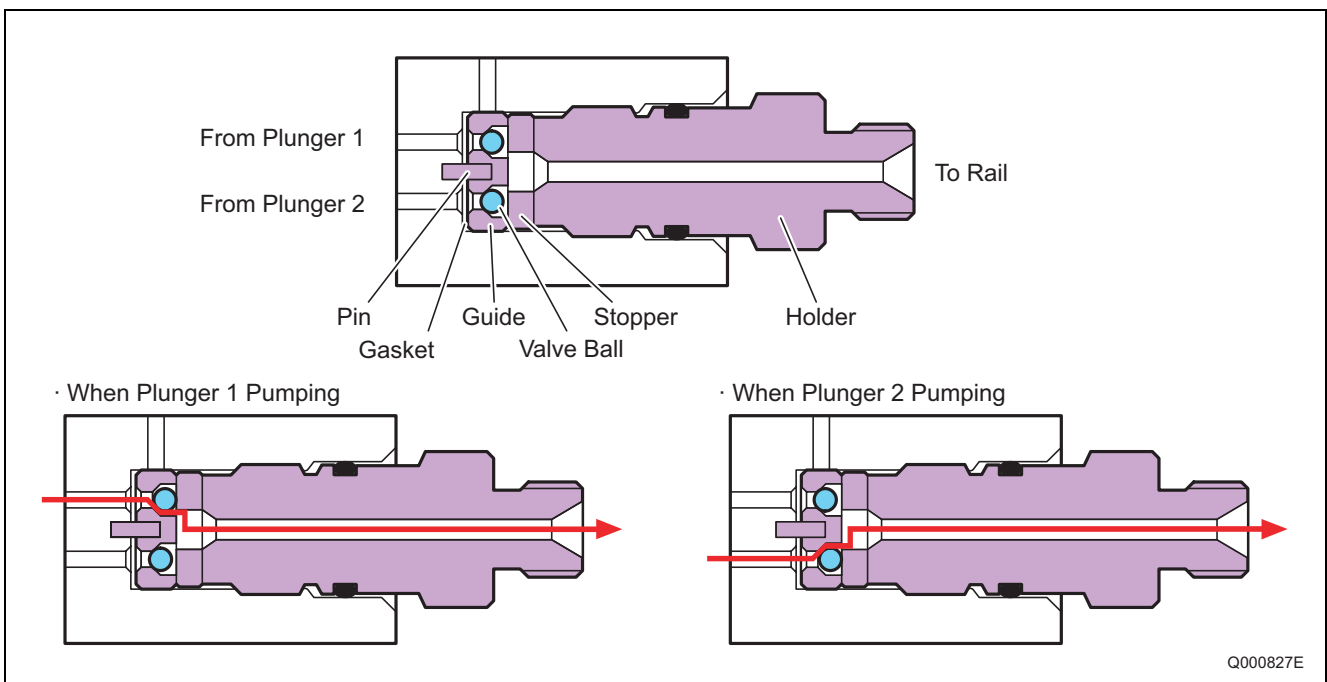

Fuel Temperature Sensor

- The fuel temperature sensor is installed on the fuel intake side and utilizes the characteristics of a thermistor in which the electric resistance changes with the temperature in order to detect the fuel temperature.

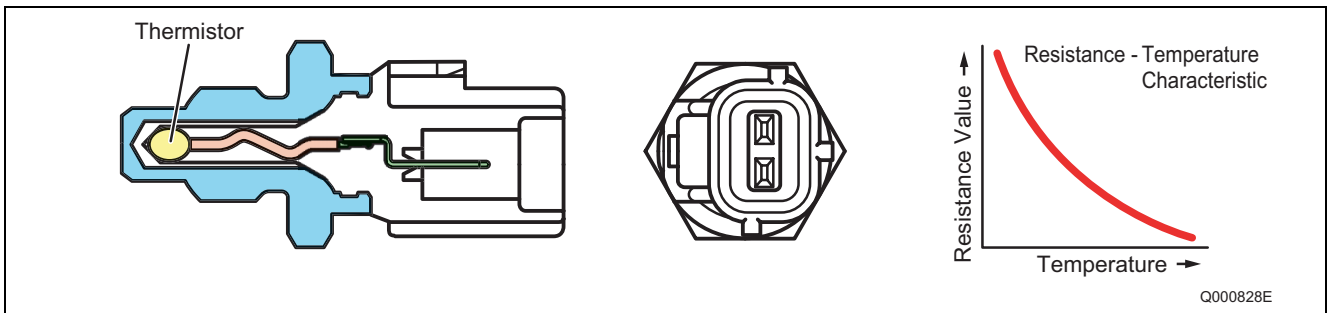

Check Valve

- The check valve, which is located between the SCV (Suction Control Valve) and the pumping mechanism, prevents the pressurized fuel in the pumping mechanism from flowing back into the SCV.

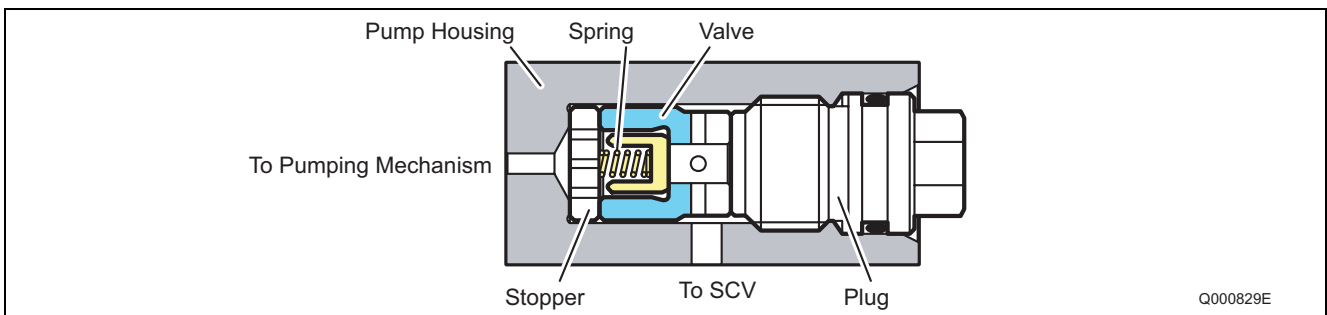

Check Valve Open

- During fuel suction (SCV ON), the feed pressure opens the valve, allowing fuel to be drawn into the pumping mechanism.

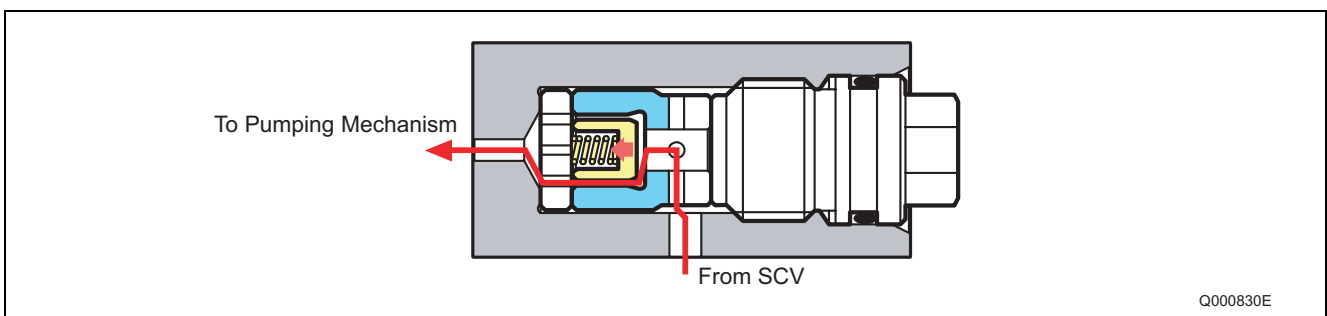

Check Valve Closed

- During fuel pumping (SCV OFF), the pressurized fuel in the pumping mechanism closes the valve, preventing fuel from flowing back into the SCV.

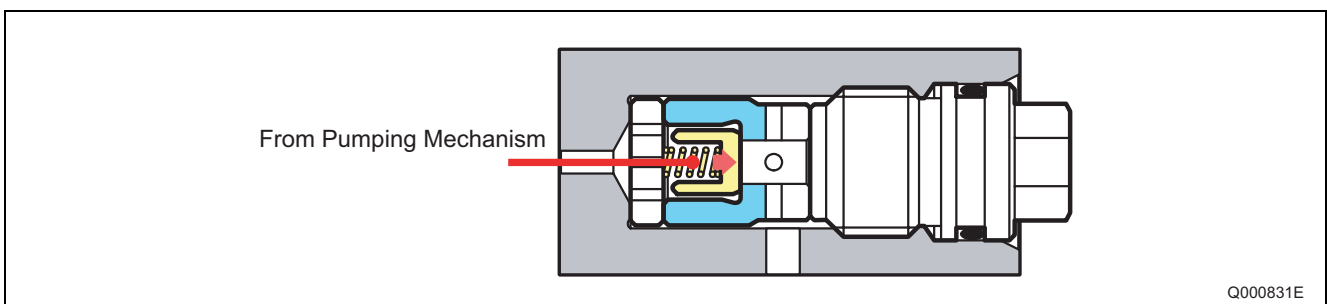

(5) Supply Pump Operation

Supply Pump Overall Fuel Flow

- Fuel is suctioned by the feed pump from the fuel tank and sent to the SCV. At this time, the regulating valve adjusts the fuel pressure to below a certain level. Fuel sent to the feed pump has the required discharge quantity adjusted by the SCV and enters the pumping mechanism through the check valve. The fuel pumped by the pumping mechanism is pumped through the delivery valve to the rail.

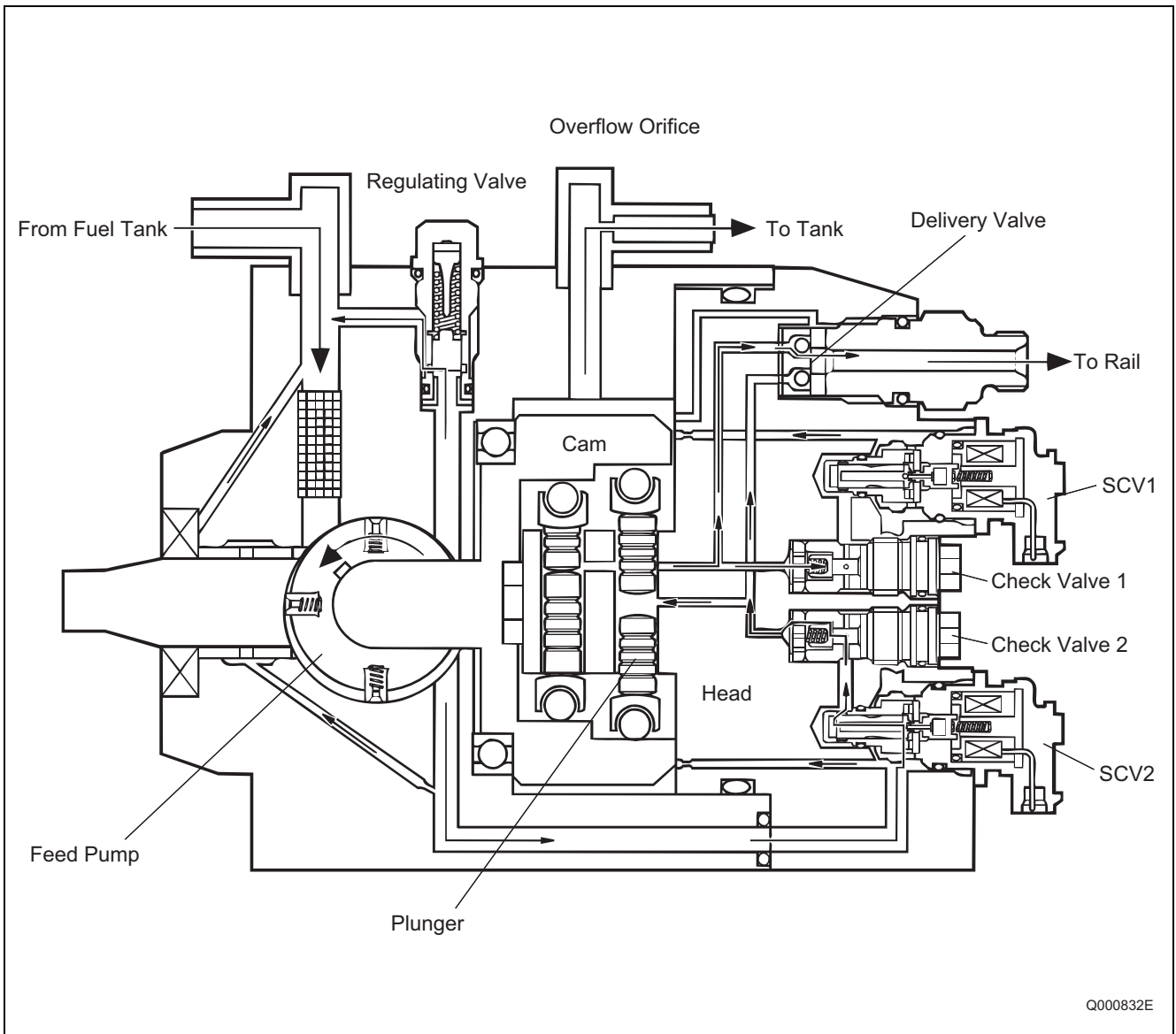

Fuel Discharge Quantity Control

- The diagram below shows that the suction starting timing (SCV (Suction Control Valve) ON) is constant (determined by the pump speed) due to the crankshaft position sensor signal. For this reason, the fuel suction quantity is controlled by changing the suction ending timing (SCV OFF). Hence, the suction quantity decreases when the SCV is turned OFF early and the quantity increases when the SCV is turned OFF late.
- During the intake stroke, the plunger receives the fuel feed pressure and descends along the cam surface. When the SCV turns OFF (suction end), the feed pressure on the plunger ends and the descent stops. Since the suction quantity varies, when suction ends (except for maximum suction) the roller separates from the cam surface.
- When the drive shaft rotates and the cam peak rises and the roller comes in contact with the cam surface again, the plunger is pressed by the cam and starts pumping. Since the suction quantity = the discharge quantity, the discharge quantity is controlled by the timing with which the SCV is switched OFF (suction quantity).

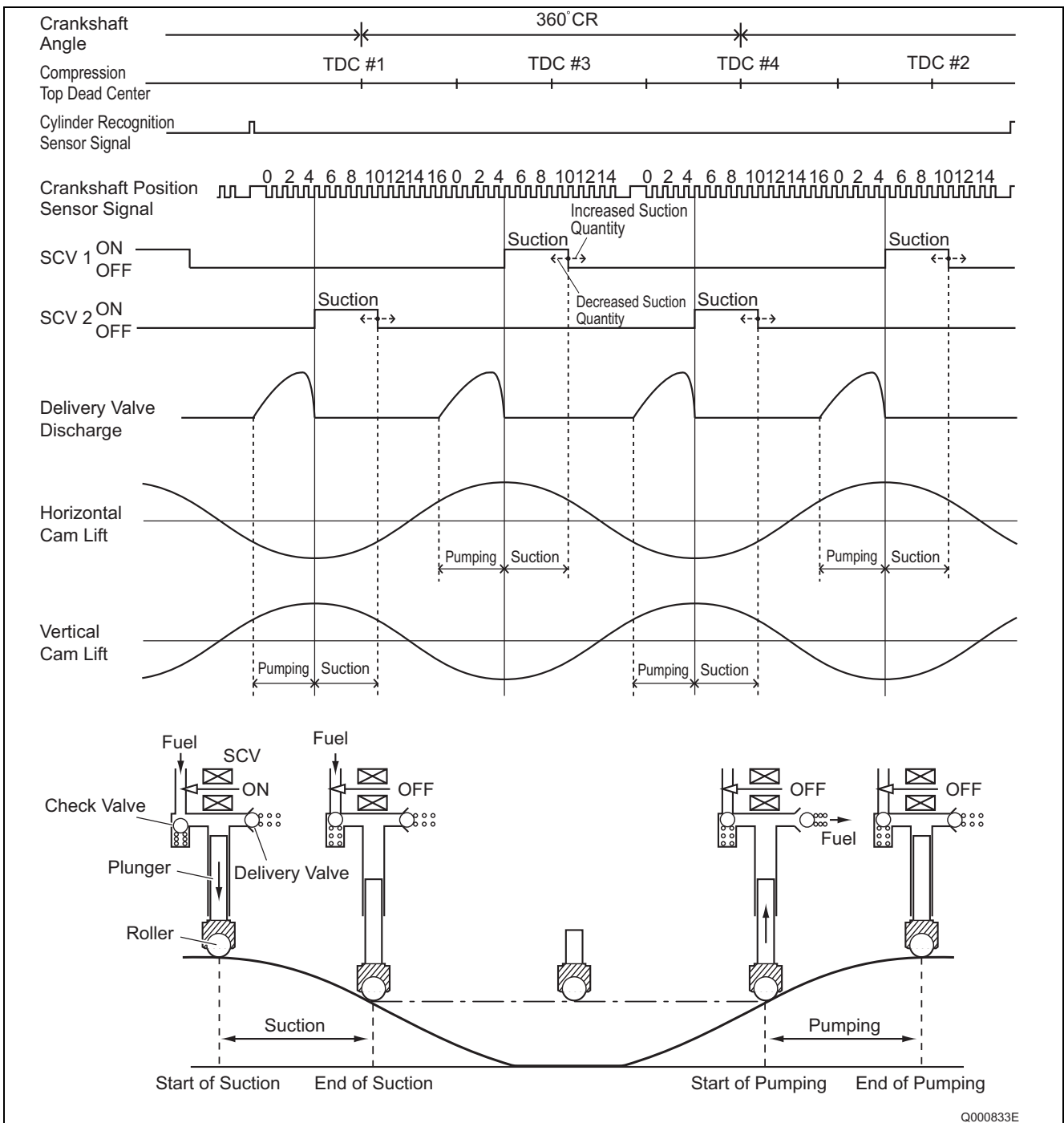

3.3 HP3 Type

(1) Construction and Characteristics

- The supply pump is primarily composed of the pump unit (eccentric cam, ring cam, two plungers), the SCV (suction control valve), the fuel temperature sensor and the feed pump (trochoid type), and is actuated at 1/1 or 1/2 the engine rotation.
- The two compact pump unit plungers are positioned symmetrically above and below on the outside of the ring cam.
- The fuel discharge quantity is controlled by the SCV, the same as for the HP2, in order to reduce the actuating load and suppress the rise in fuel temperature. In addition, there are two types of HP3 SCV: the normally open type (the suction valve opens when not energized) and the normally closed type (the suction valve is closed when not energized).
- With a DPNR system (Diesel Particulate NOx Reduction) system, there is also a flow damper. The purpose of this flow damper is to automatically shut off the fuel if a leak occurs in the fuel addition valve passage within the DPNR.

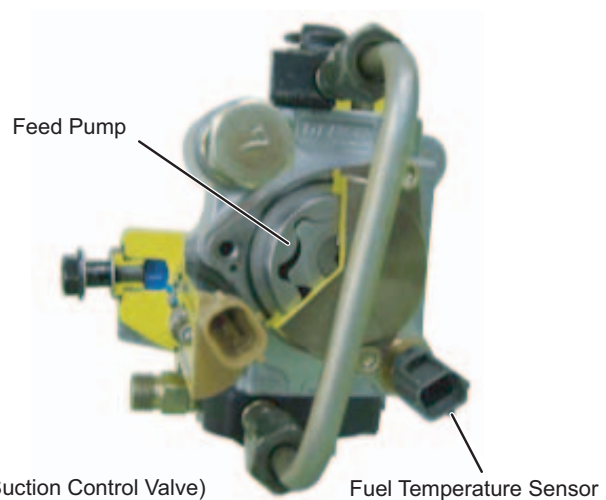
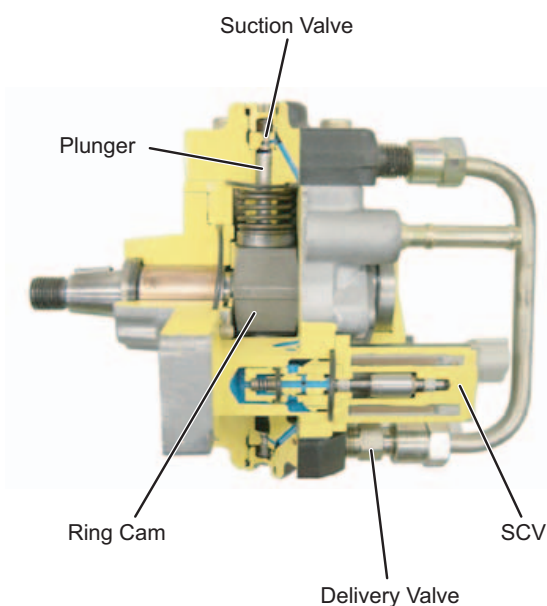
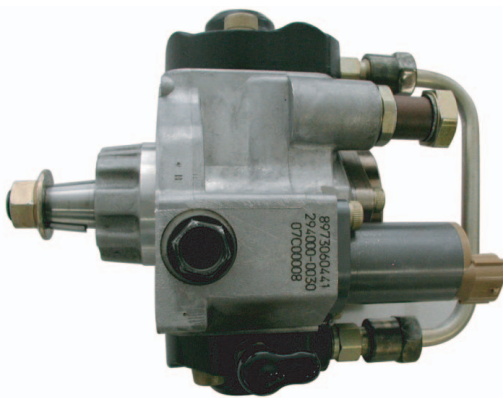

(2) Exploded View

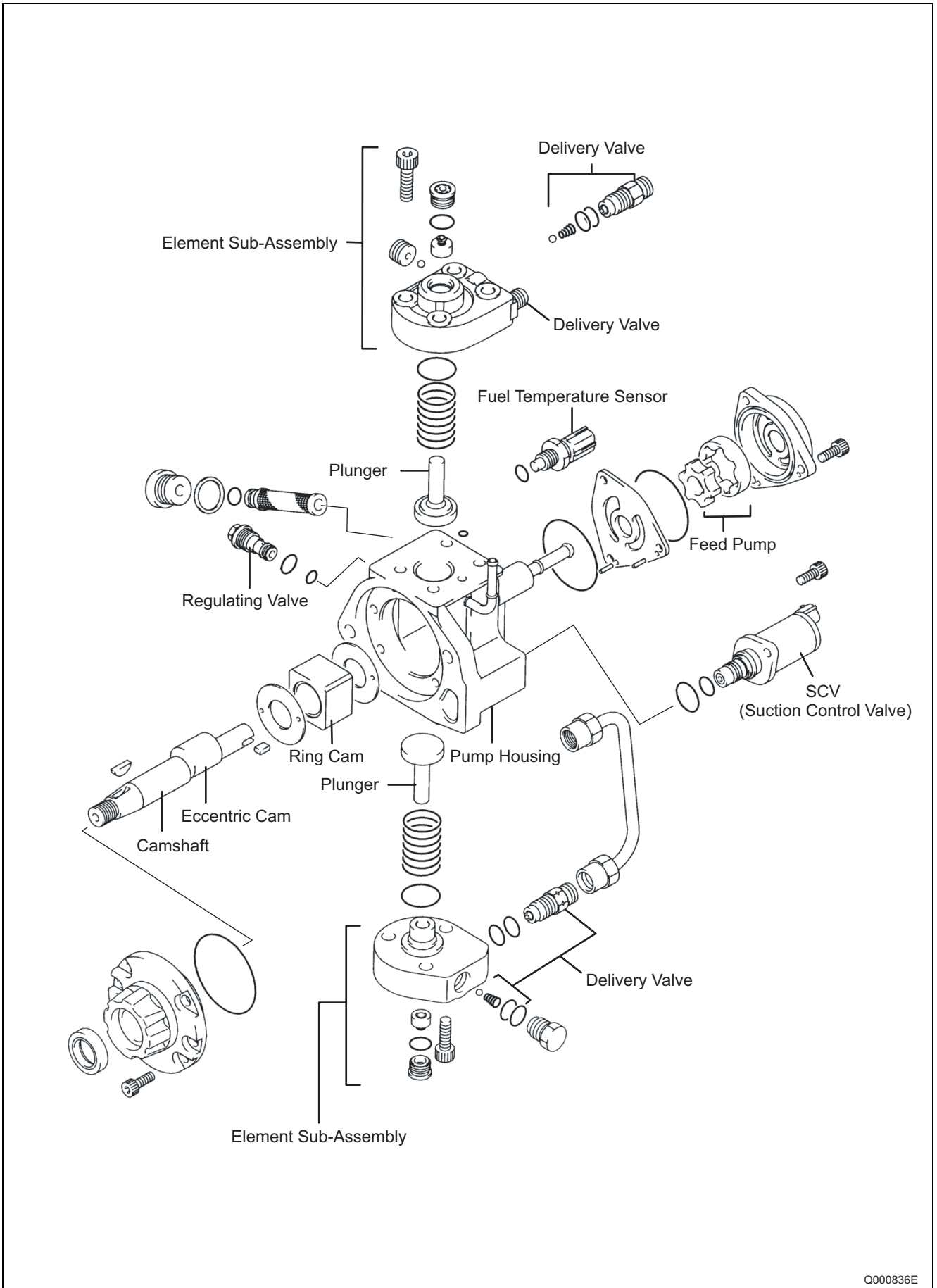

(3) Component Part Functions

Component Parts		Functions
Feed Pump		Draws fuel from the fuel tank and feeds it to the plunger.
Regulating Valve		Regulates the pressure of the fuel in the supply pump.
SCV (Suction Control Valve)		Controls the quantity of fuel that is fed to the plungers.
Pump Unit	Eccentric Cam	Actuates the ring cam.
	Ring Cam	Actuates the plunger.
	Plunger	Moves reciprocally to draw and compress fuel.
Delivery Valve		Prevents reverse flow from the rail of the fuel pumped from the plunger.
Fuel Temperature Sensor		Detects the fuel temperature.

Feed Pump

- The trochoid type feed pump, which is integrated in the supply pump, draws fuel from the fuel tank and feeds it to the two plungers via the fuel filter and the SCV (Suction Control Valve). The drive shaft actuates the outer/inner rotors of the feed pump, thus causing the rotors to start rotating. In accordance with the space that increases and decreases with the movement of the outer and inner rotors, the feed pump draws fuel into the suction port and pumps fuel out the discharge port.

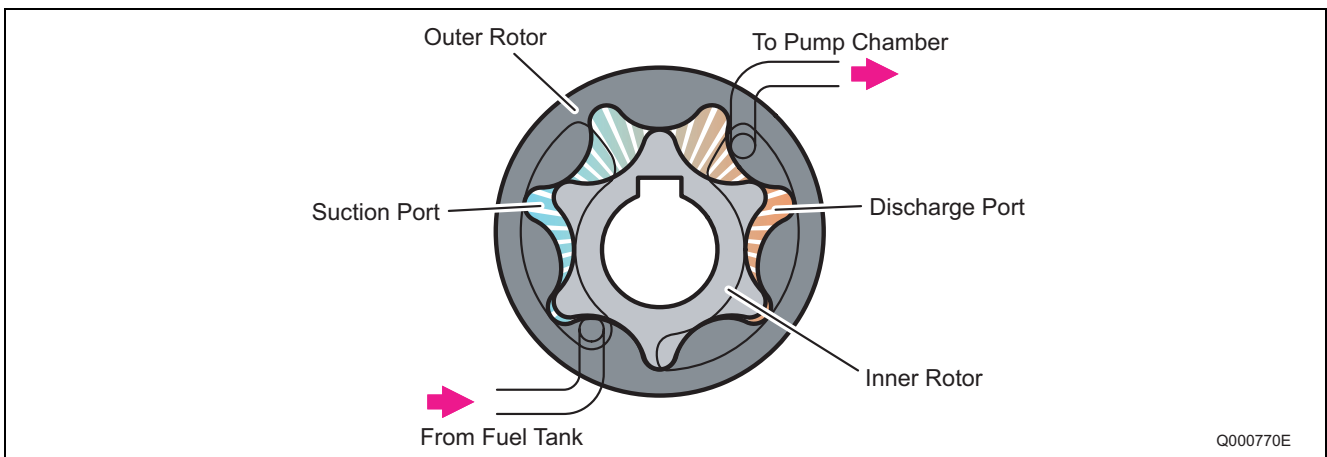

Regulating Valve

- The regulating valve keeps the fuel feed pressure (discharge pressure) below a certain level. If the pump speed increases and the feed pressure exceeds the preset pressure of the regulating valve, the valve opens by overcoming the spring force in order to return the fuel to the suction side.

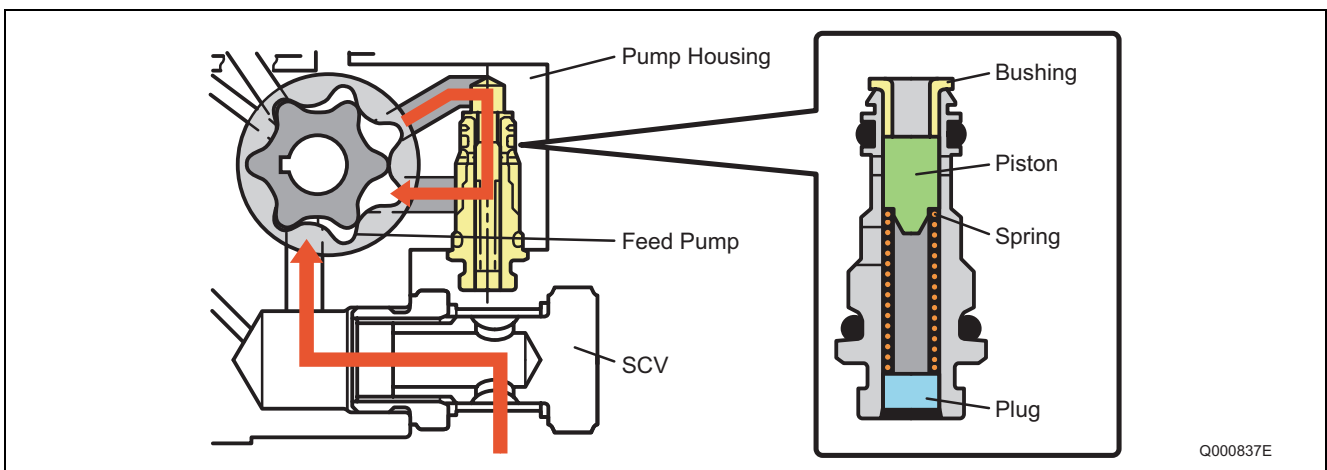

Suction Control Valve (SCV)

- In contrast to the HP2, the SCV for the HP3 supply pump is equipped with a linear solenoid valve. The fuel flow volume supplied to the high-pressure plunger is controlled by adjusting the engine ECU supplies power to the SCV (duty ratio control). When current flows to the SCV, the internal armature moves according to the duty ratio. The armature moves the needle valve, controlling the fuel flow volume according to the amount that the valve body fuel path is blocked. Control is performed so that the supply pump suction only the necessary fuel quantity to achieve the target rail pressure. As a result, the supply pump actuation load is reduced.
- There are two types of HP3 SCV: the normally open type (the suction valve opens when not energized) and the normally closed type (the suction valve is closed when not energized). The operation of each type is the reverse of that of the other.
- In recent years, a compact SCV has been developed. Compared to the conventional SCV, the position of the return spring and needle valve in the compact SCV are reversed. For this reason, operation is also reversed.

Normally Open Type

- When the solenoid is not energized, the return spring pushes against the needle valve, completely opening the fuel passage and supplying fuel to the plungers. (Total quantity suctioned → Total quantity discharged)
- When the solenoid is energized, the armature pushes the needle valve, which compresses the return spring and closes the fuel passage. In contrast, the needle valve in the compact SCV is pulled upon, which compresses the return spring and closes the fuel passage.
- The solenoid ON/OFF is actuated by duty ratio control. Fuel is supplied in an amount corresponding to the open surface area of the passage, which depends on the duty ratio, and then is discharged by the plungers.

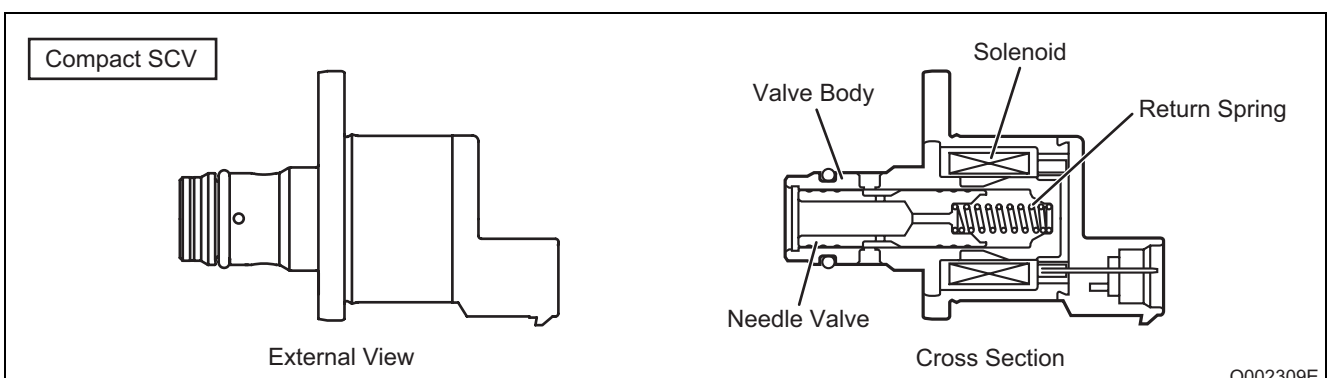
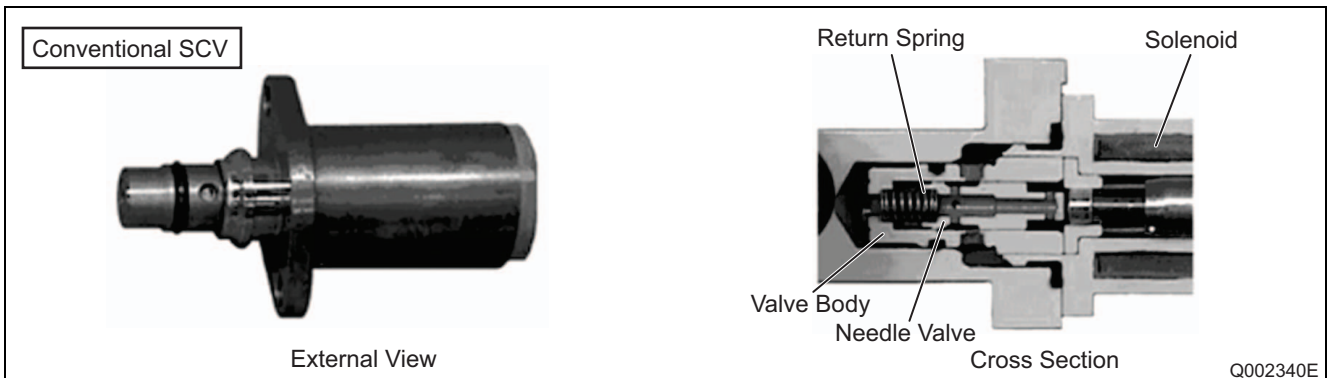

Duty Ratio Control

- The engine ECU outputs sawtooth wave signals with a constant frequency. The value of the current is the effective (average) value of these signals. As the effective value increases, the valve opening decreases, and as the effective value decreases, the valve opening increases.

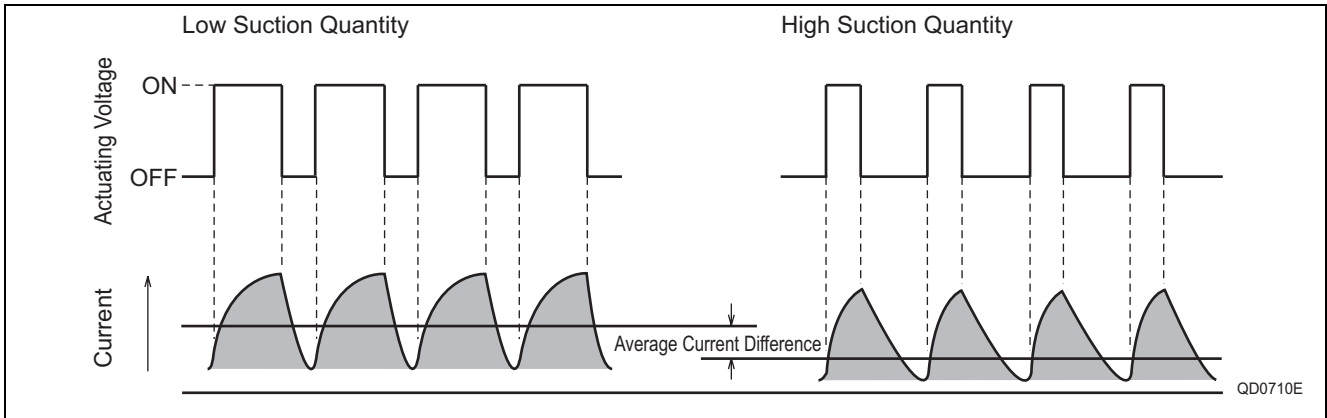

When the SCV Energized Duration (Duty ON Time) is Short

- When the SCV energization time is short, the average current flowing through the solenoid is small. As a result, the needle valve is returned by spring force, creating a large valve opening. Subsequently, the fuel suction quantity increases.

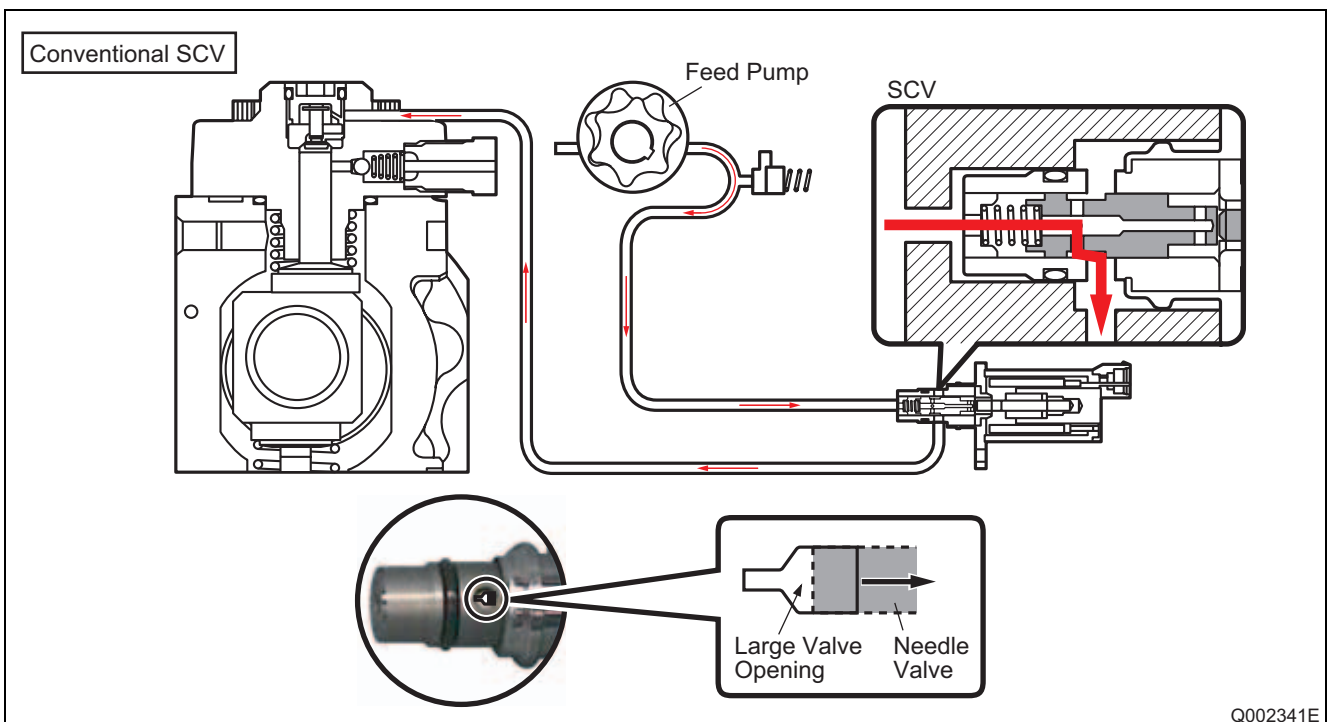

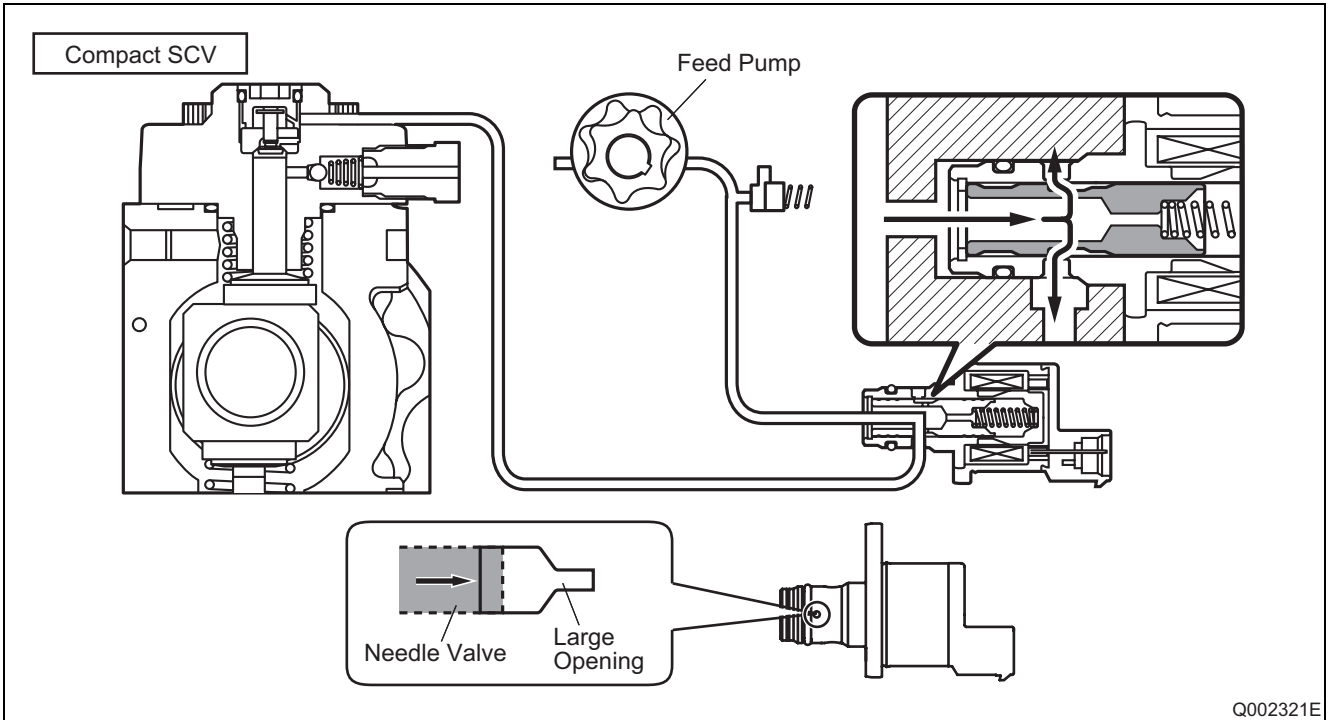

Q002321E

When the SCV Energized Duration (Duty ON Time) is Long

- When the energization time is long, the average current flowing to the solenoid is large. As a result, the needle valve is pressed out (in the compact SCV, the needle valve is pulled), creating a small valve opening. Subsequently, the fuel suction quantity decreases.

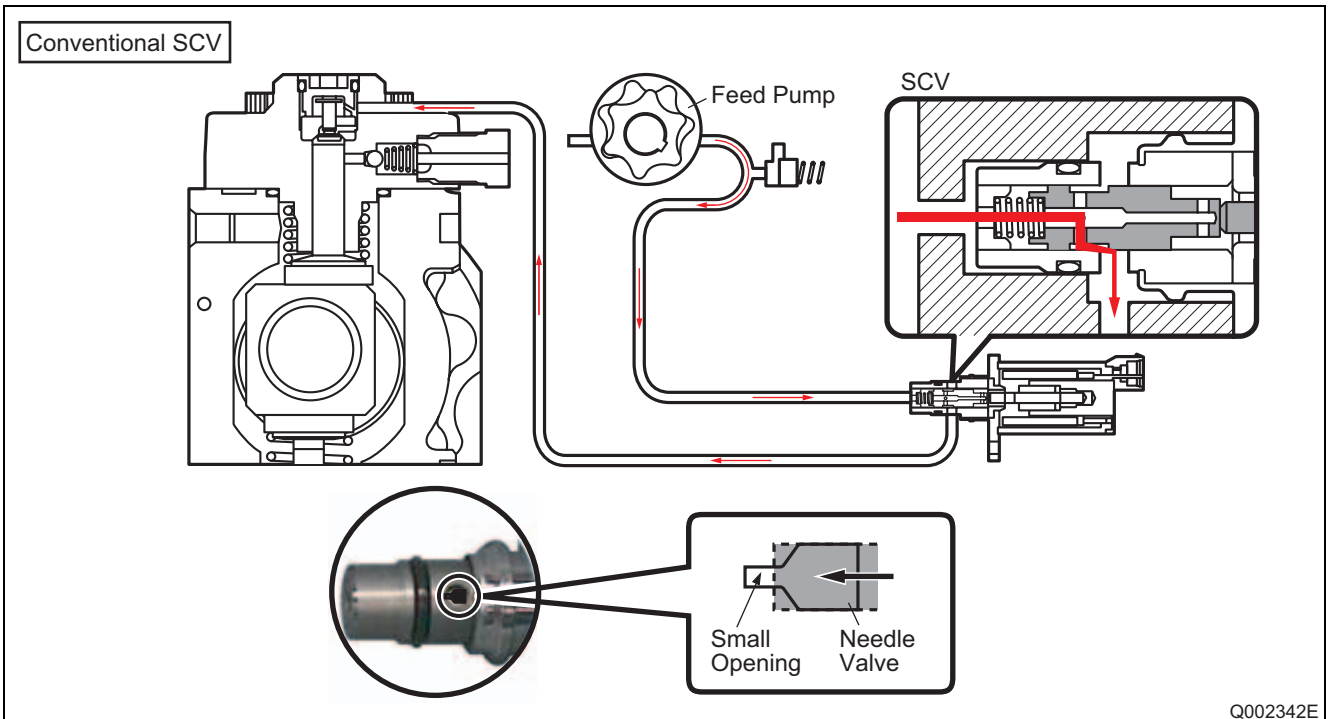

Q002342E

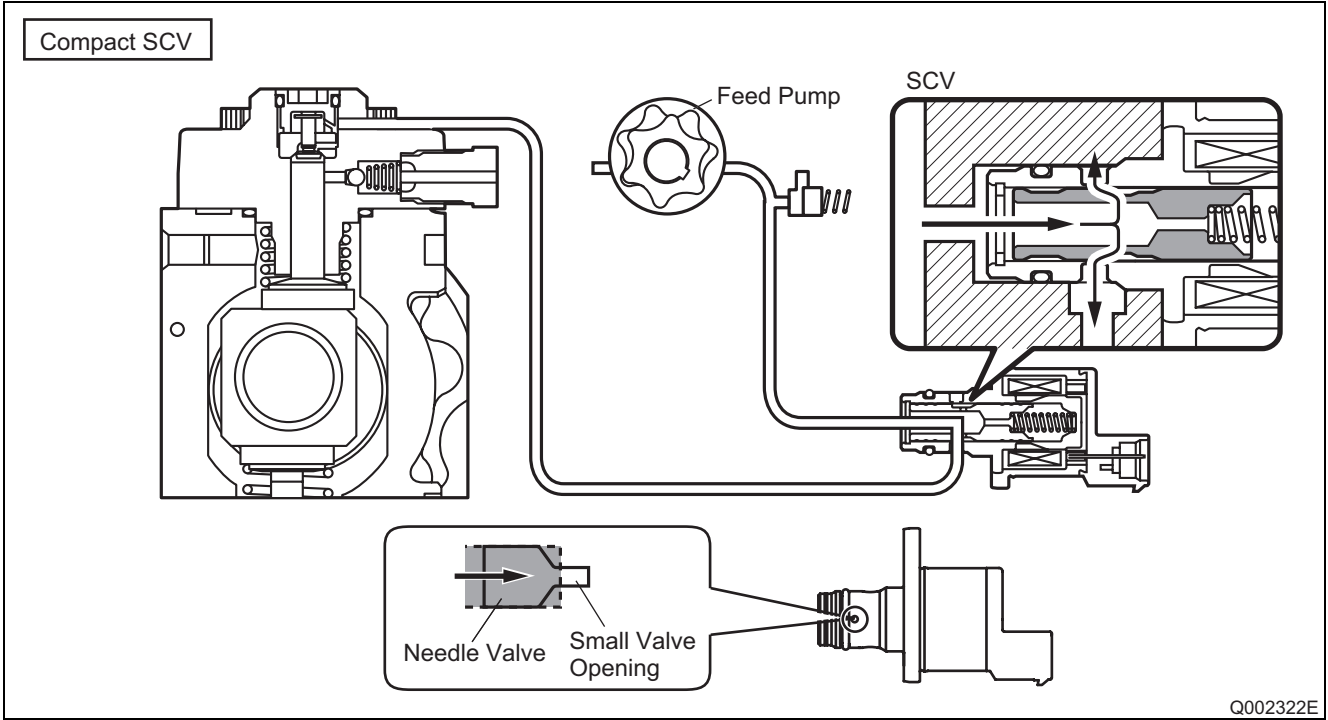

Normally Closed Type

- When the solenoid is energized, the needle valve is pressed upon (in the compact SCV, the cylinder is pulled upon) by the armature, completely opening the fuel passage and supplying fuel to the plunger. (Total quantity suctioned → Total quantity discharged)
- When power is removed from the solenoid, the return spring presses the needle valve back to the original position, closing the fuel passage.
- The solenoid ON/OFF is actuated by duty ratio control. Fuel is supplied in an amount corresponding to the open surface area of the passage, which depends on the duty ratio, and then is discharged by the plungers.

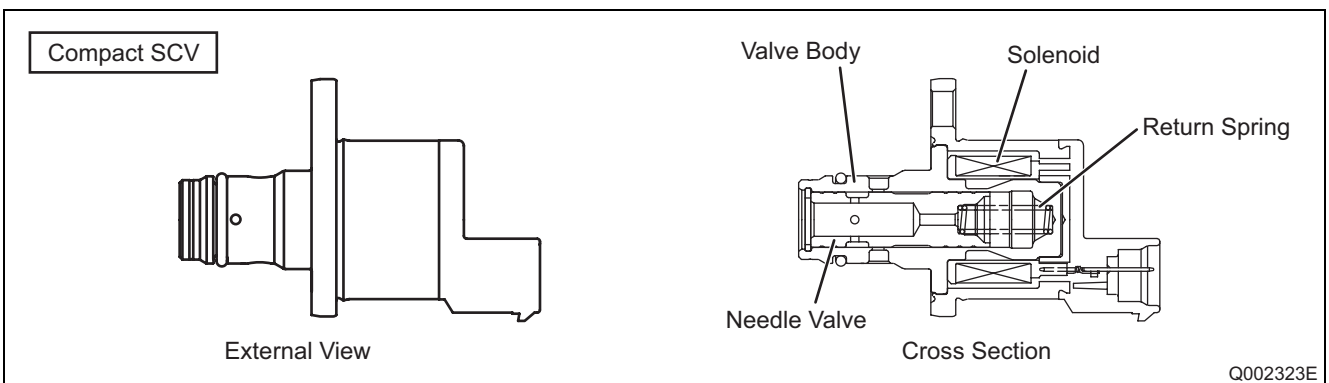
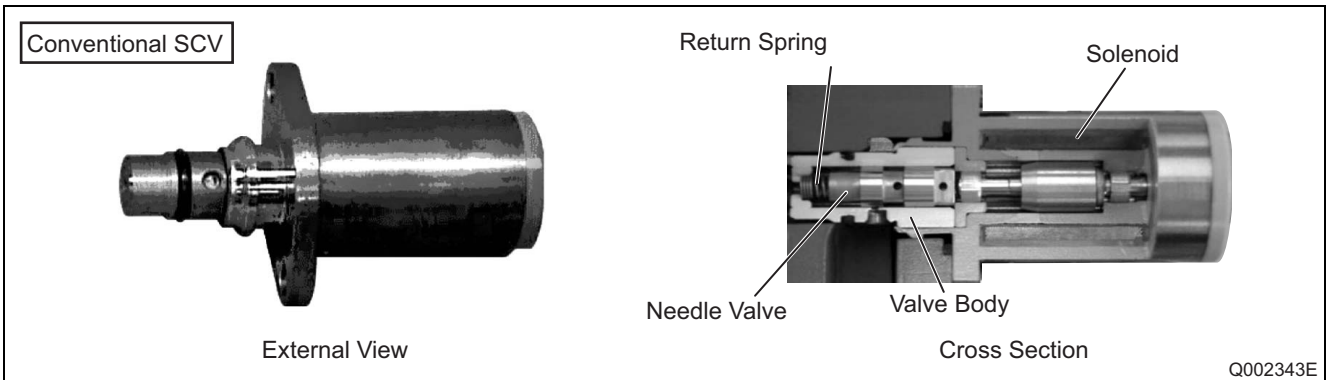

Duty Ratio Control

- The engine ECU outputs sawtooth wave signals with a constant frequency. The value of the current is the effective (average) value of these signals. As the effective value increases, the valve opening increases, and as the effective value decreases, the valve opening decreases.

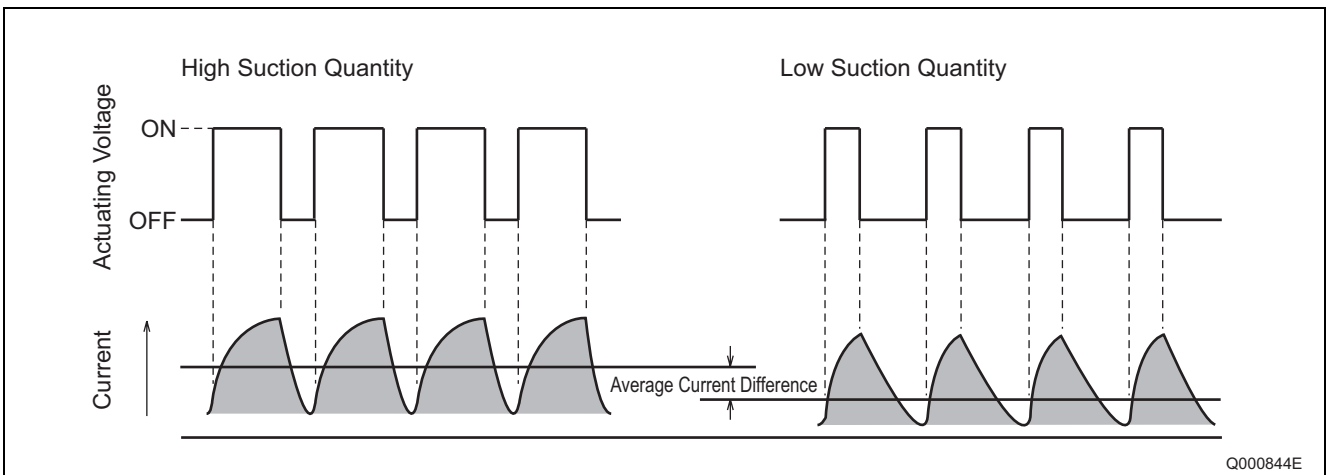

When the SCV Energized Duration (Duty ON Time) is Long

- When the energization time is long, the average current flowing to the solenoid is large. As a result, the needle valve is pushed out (in the compact SCV, the needle valve is pulled), creating a large valve opening. Subsequently, the fuel suction quantity increases.

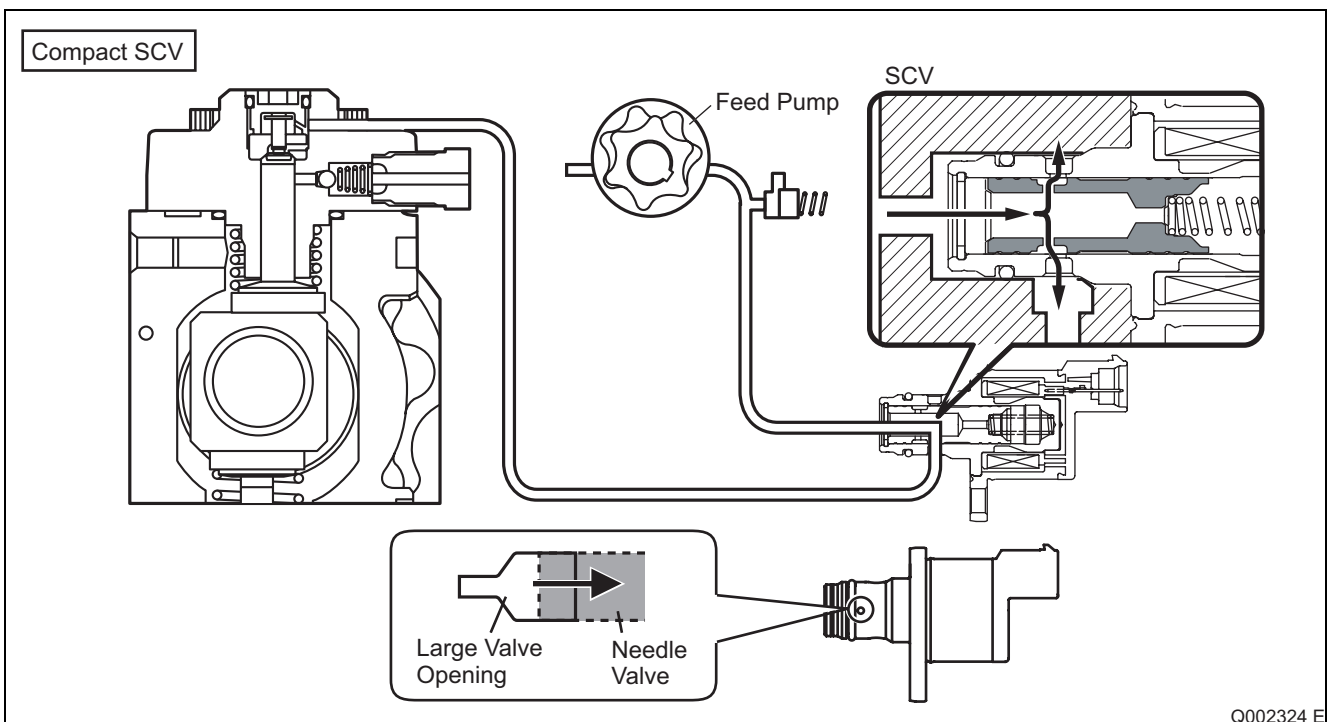
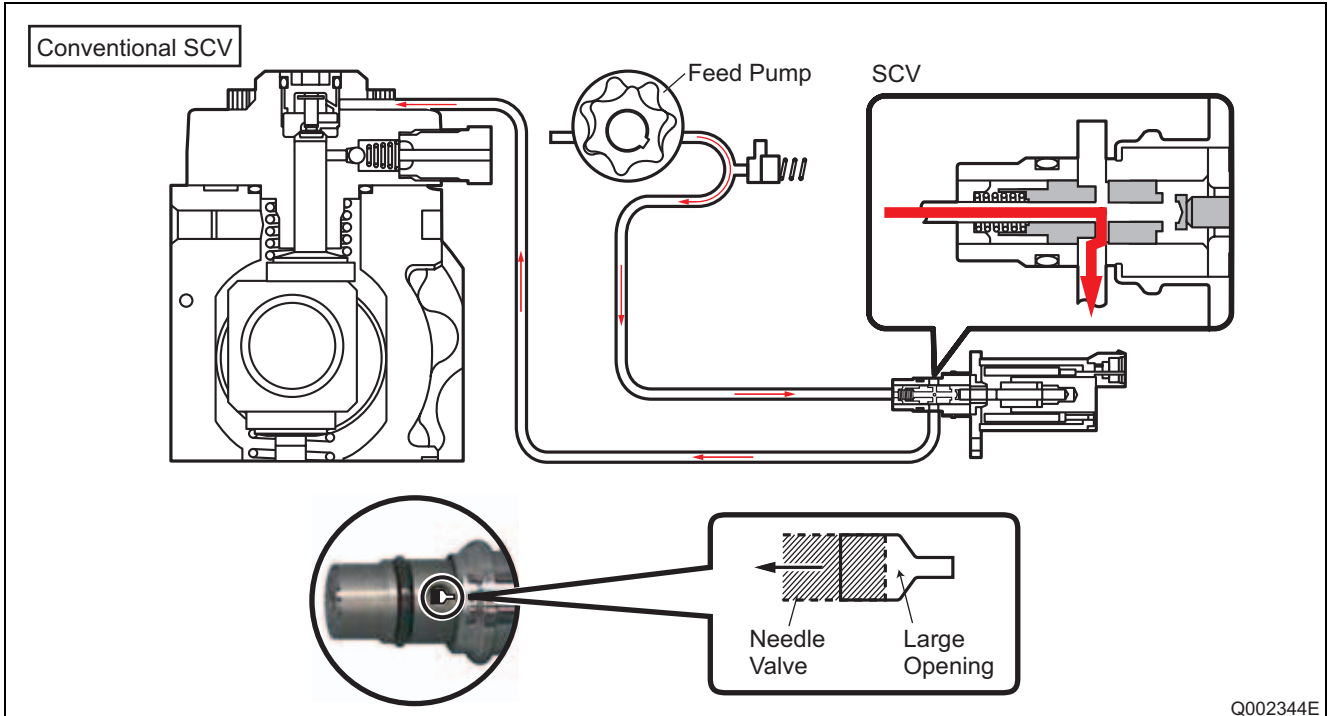

When the SCV Energized Duration (Duty ON Time) is Short

- When the energization time is short, the average current flowing through the solenoid is small. As a result, the needle valve is returned to the original position by spring force, creating a small valve opening. Subsequently, the fuel suction quantity decreases.

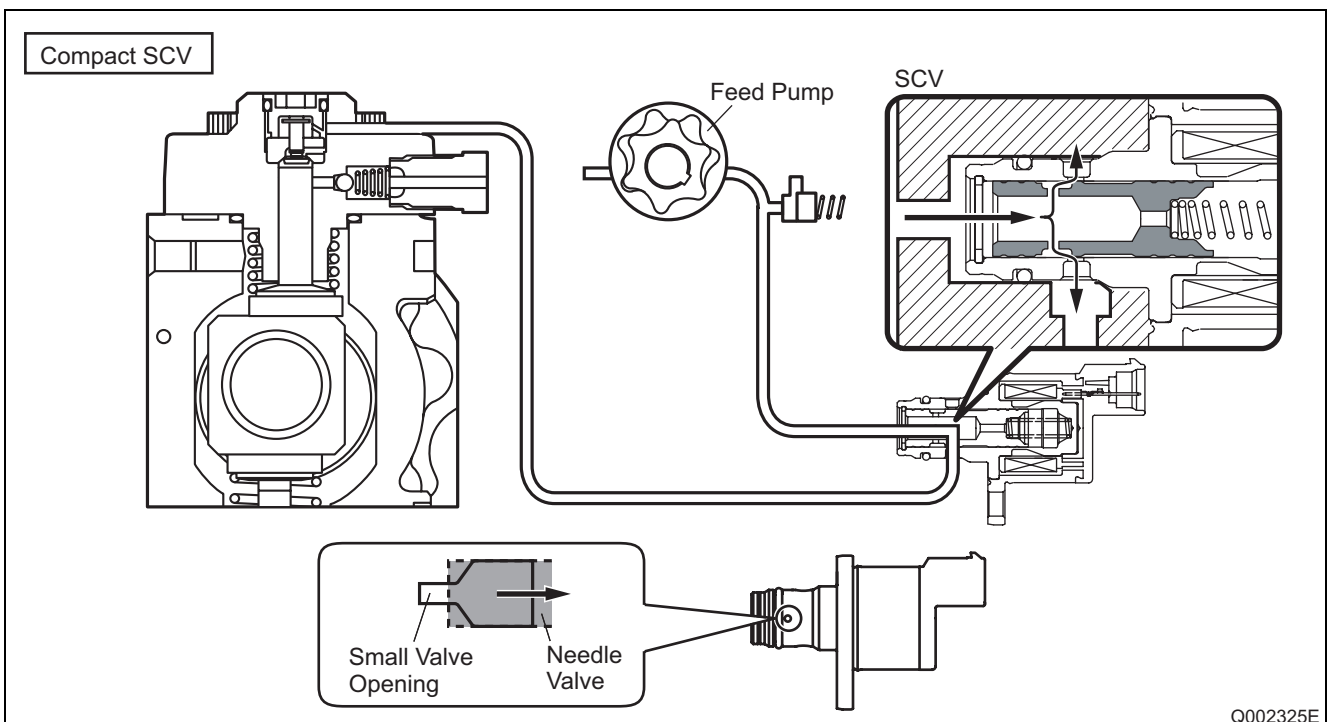
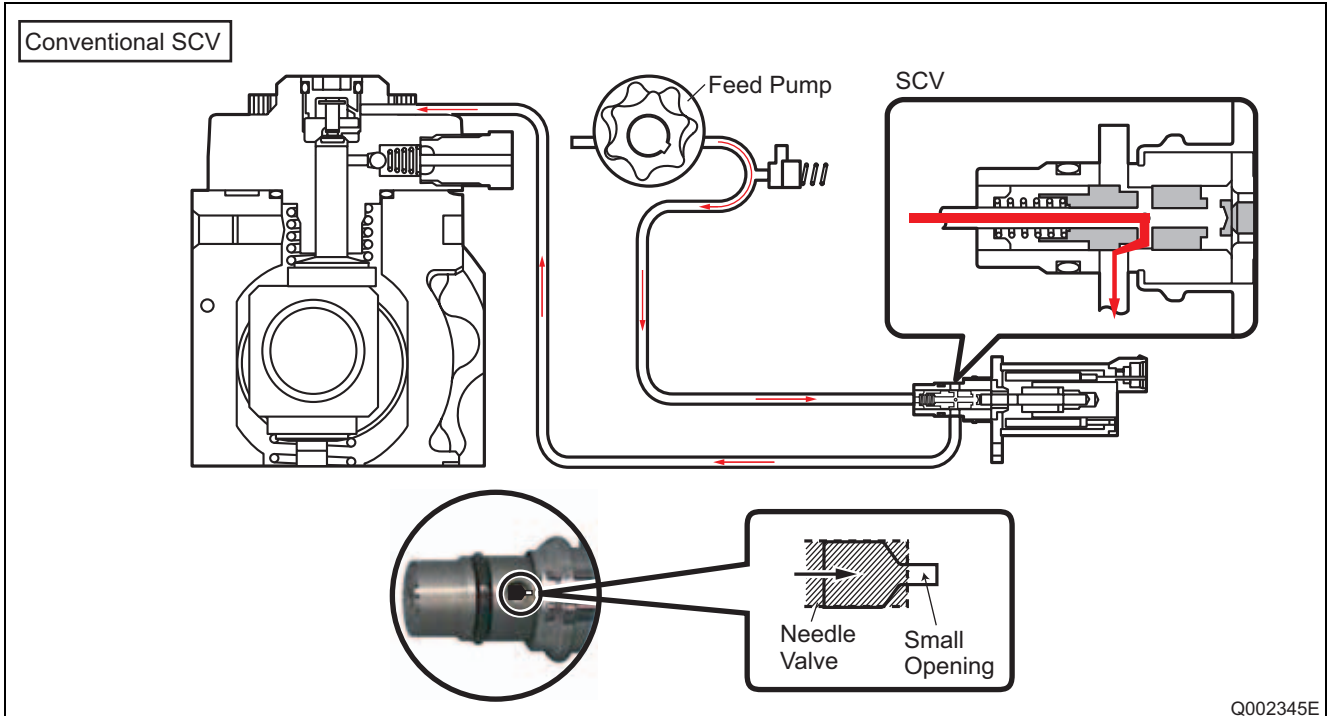

Pump Unit (Eccentric Cam, Ring Cam, Plunger)

- The eccentric cam is attached to the camshaft and the ring cam is installed on the eccentric cam. There are two plungers at positions symmetrical above and below the ring cam.

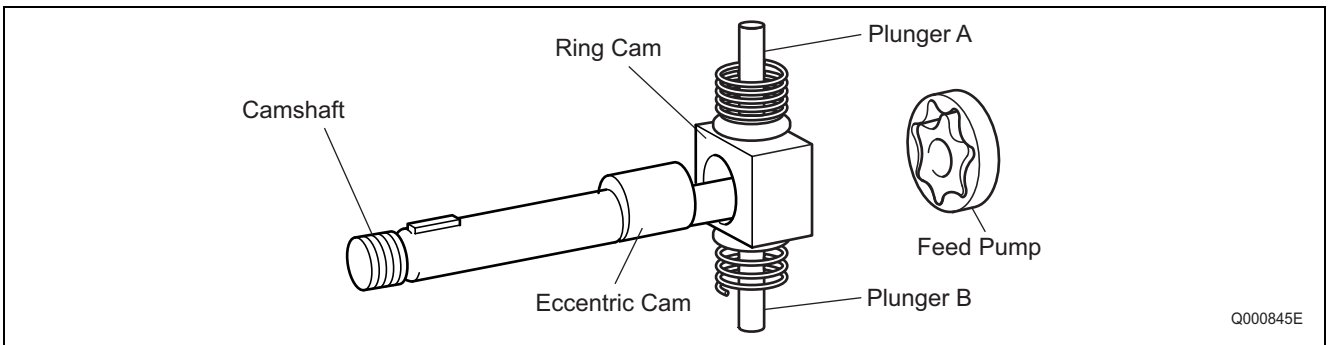

Q000845E

- Because the rotation of the camshaft makes the eccentric cam rotate eccentrically, the ring cam follows this and moves up and down, and this moves the two plungers reciprocally. (The ring cam itself does not rotate.)

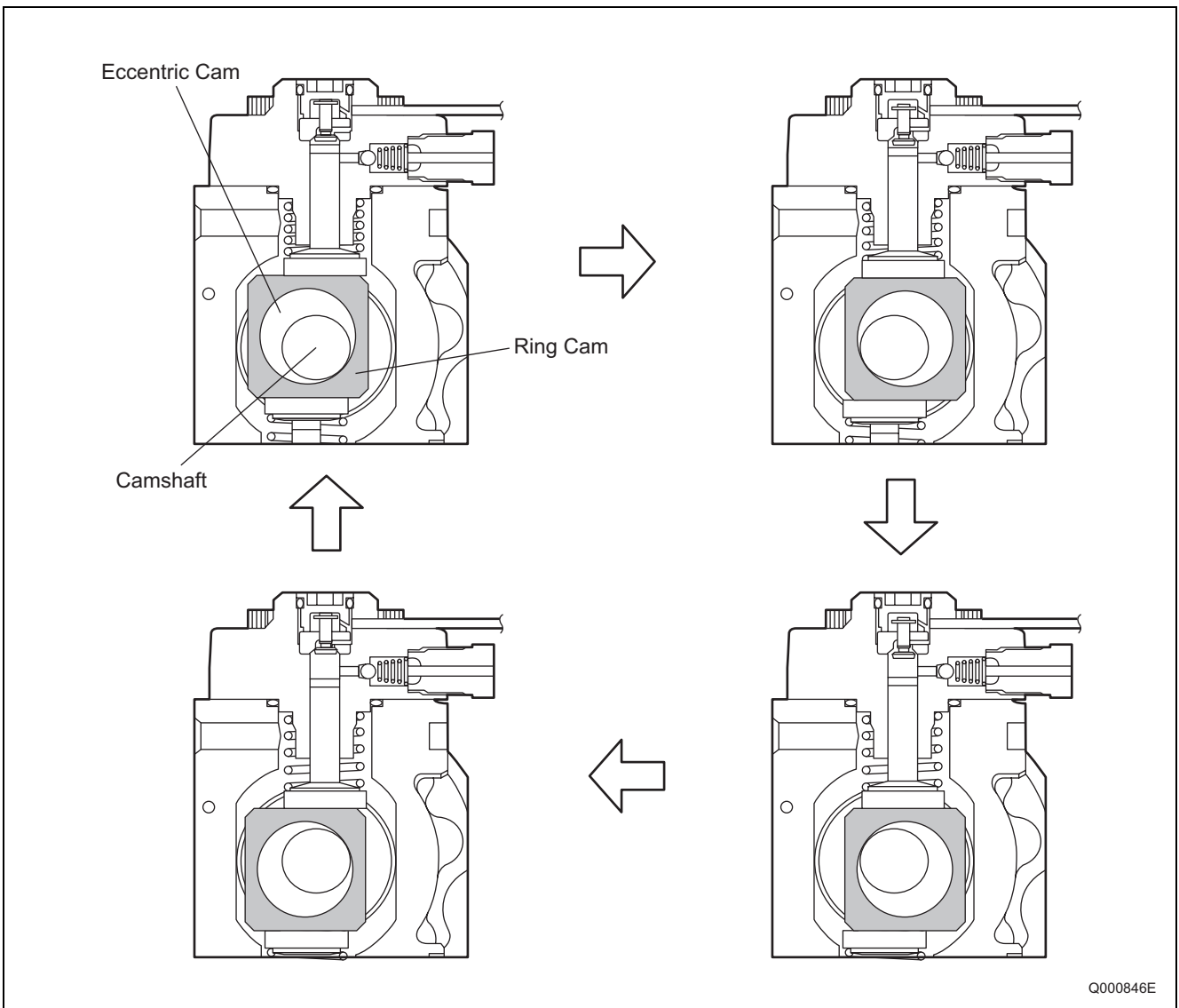

Q000846E

Delivery Valve

- The delivery valve for the HP3 has an integrated element and is made up of the check ball, spring, and holder. When the pressure at the plunger exceeds the pressure in the rail, the check ball opens to discharge the fuel.

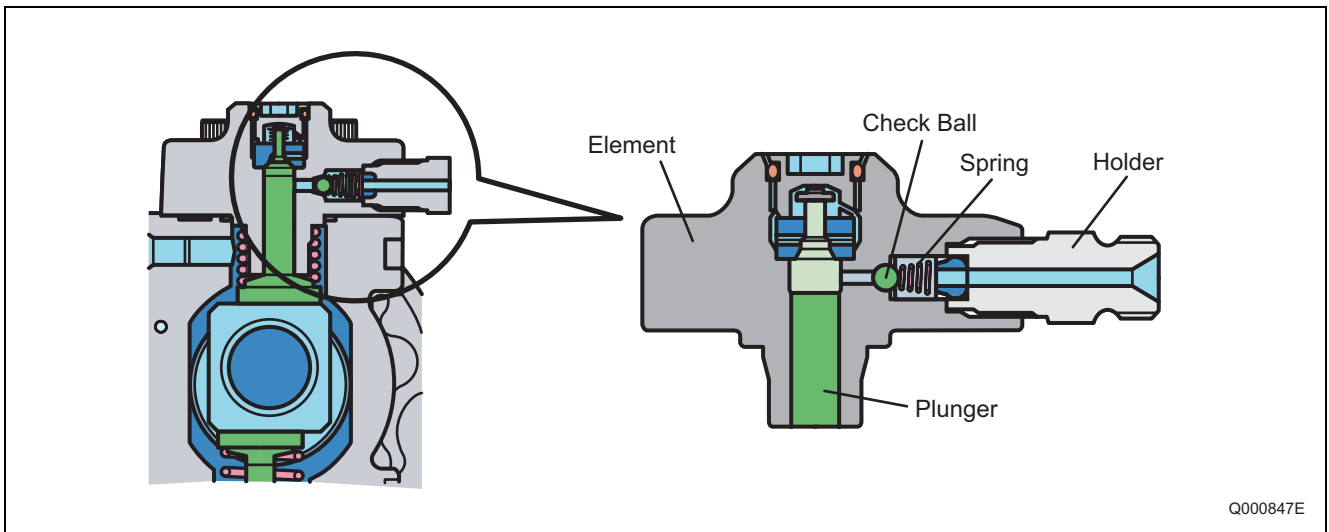
**Fuel Temperature Sensor**

- The fuel temperature sensor is installed on the fuel intake side and utilizes the characteristics of a thermistor in which the electric resistance changes with the temperature in order to detect the fuel temperature.

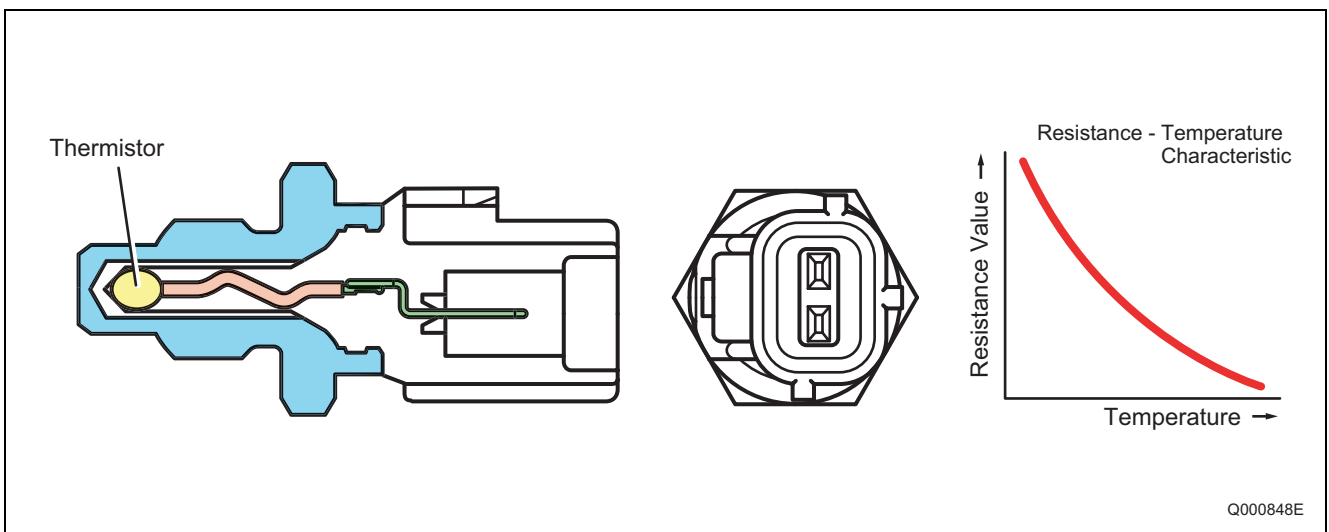

(4) Supply Pump Operation

Supply Pump Overall Fuel Flow

- The fuel is suctioned by the feed pump from the fuel tank and sent to the SCV. At this time, the regulating valve adjusts the fuel pressure to below a certain level. The fuel sent from the feed pump has the required discharge quantity adjusted by the SCV, and enters the pump unit through the suction valve. The fuel pumped by the pump unit is pumped through the delivery valve to the rail.

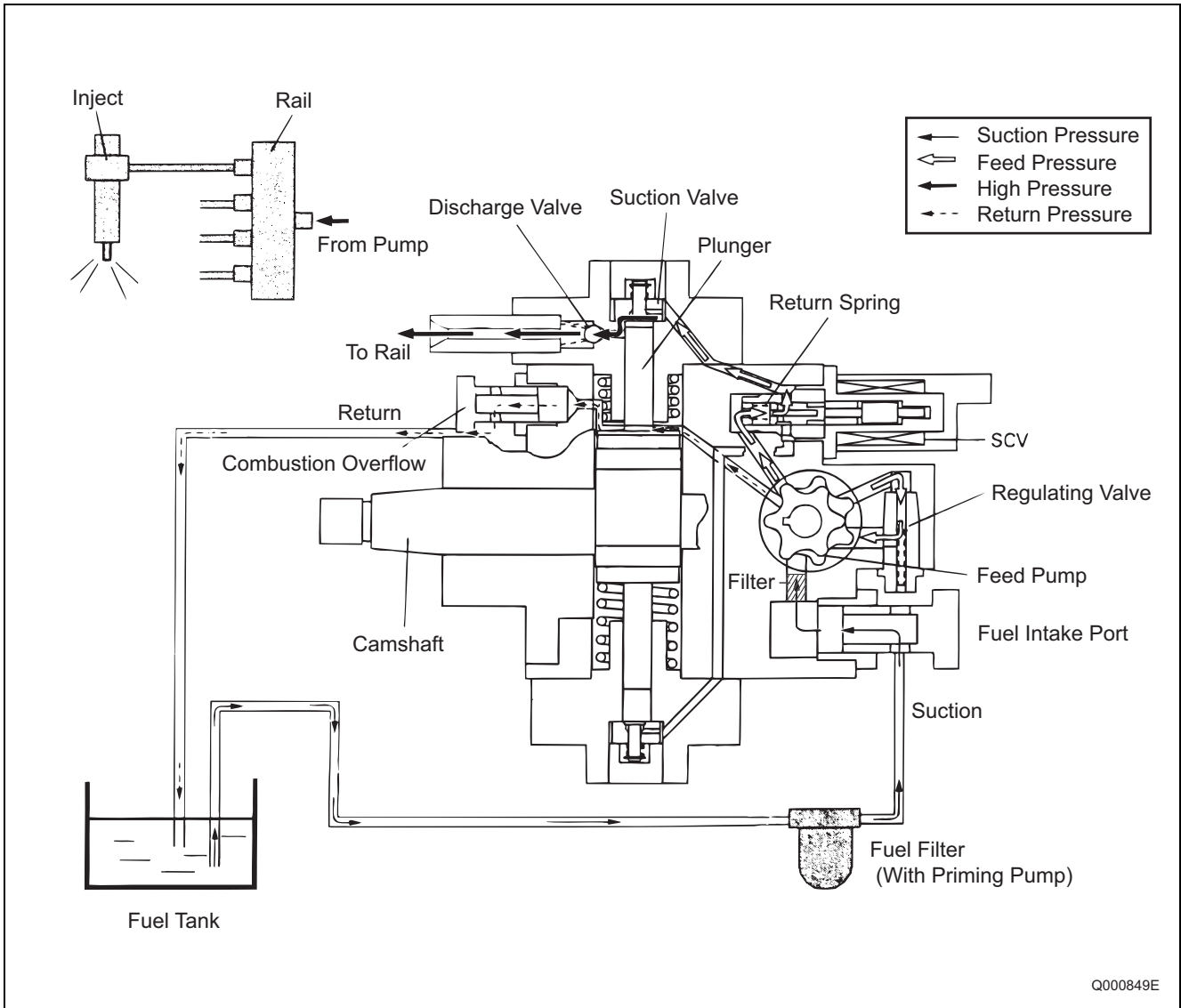

Operation

- The discharge quantity is controlled by SCV control, the same as for the HP2, however it differs from the HP2 in that the valve opening is adjusted by duty ratio control.
- In the intake stroke, the spring makes the plunger follow the movement of the ring cam, so the plunger descends together with the ring cam. Thus, unlike the HP2, the plunger itself also suctions in fuel. When the suctioned fuel passes through the SCV, the flow quantity is controlled to the required discharge quantity by the valve opening and enters the pump main unit.
- The quantity of fuel adjusted by the SCV is pumped during the pumping stroke.

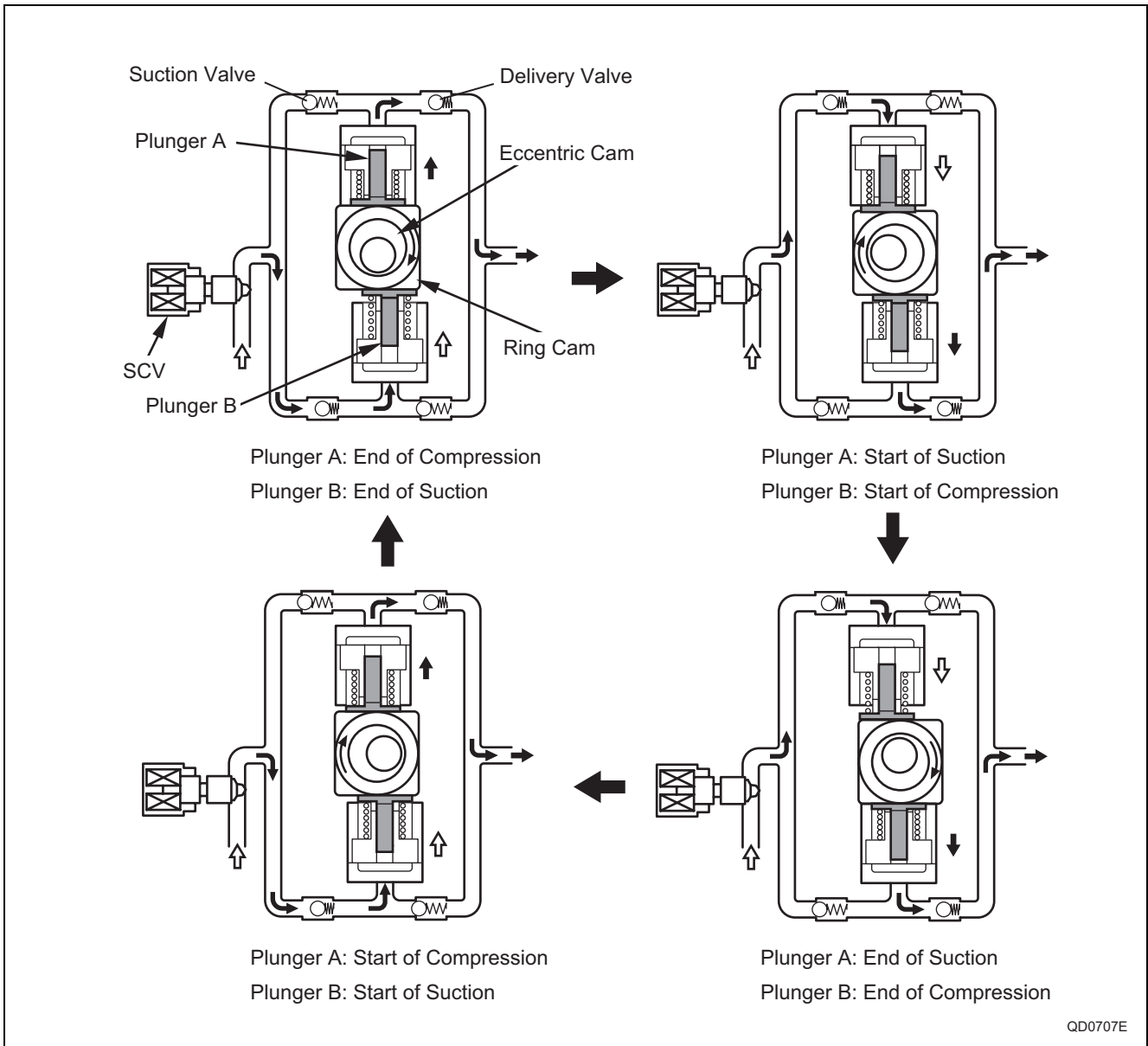

3.4 HP4 Type

(1) Construction and Characteristics

- The HP4 basic supply pump construction is the same as for the HP3. The composition is also the same as the HP3, being made up of the pump unit (eccentric cam, ring cam, plunger), the SCV (suction control valve), the fuel temperature sensor, and the feed pump. The main difference is that there are three plungers.
- Because there are three plungers, they are positioned at intervals of 120° around the outside of the ring cam. In addition, the fuel delivery capacity is 1.5 times that of the HP3.
- The fuel discharge quantity is controlled by the SCV, the same as for the HP3.

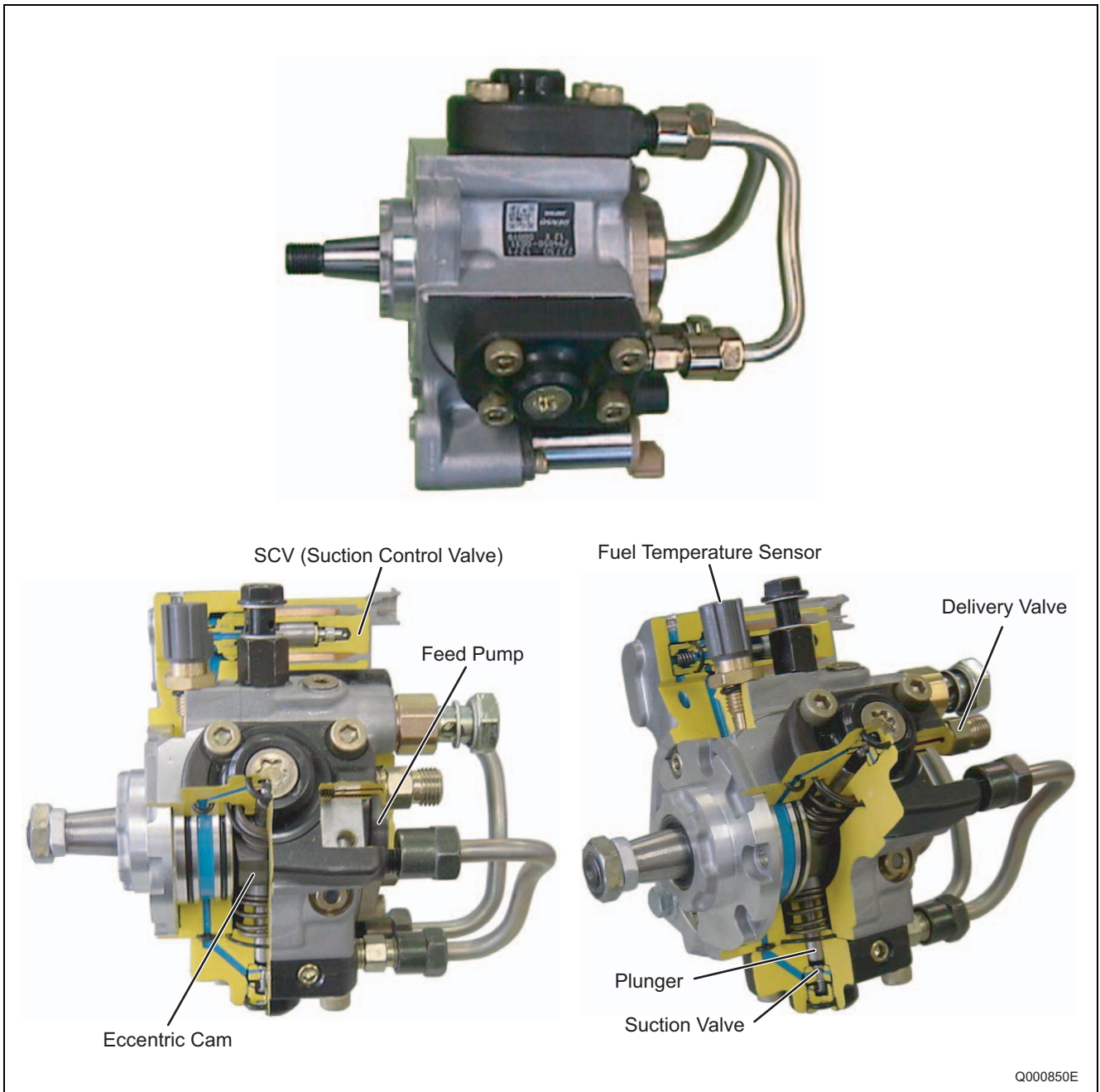

(2) Exploded View

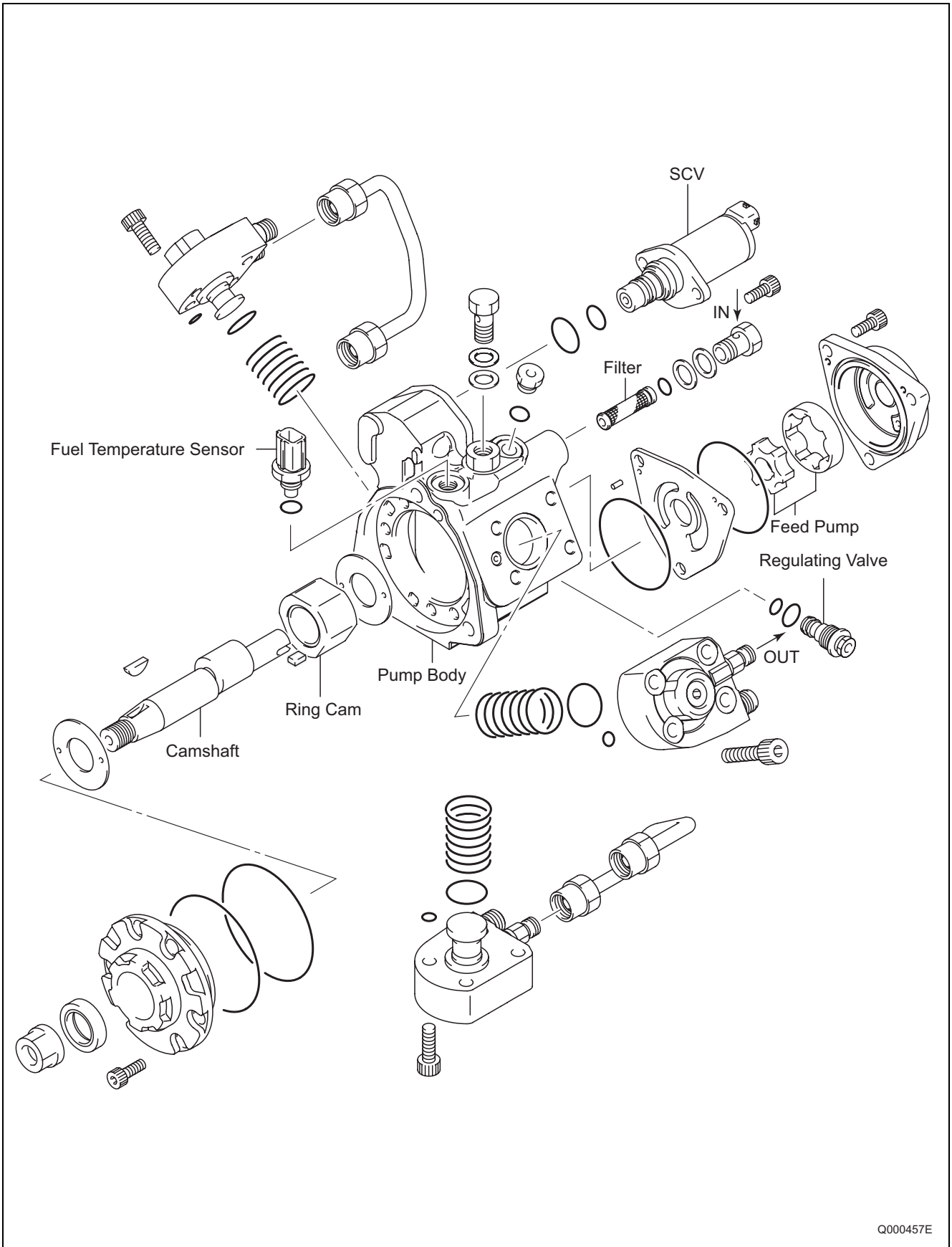

(3) Component Part Functions

Component Parts		Functions
Feed Pump		Draws fuel from the fuel tank and feeds it to the plunger.
Regulating Valve		Regulates the pressure of the fuel in the supply pump.
SCV (Suction Control Valve)		Controls the quantity of fuel that is fed to the plungers.
Pump Unit	Eccentric Cam	Actuates the ring cam.
	Ring Cam	Actuates the plunger.
	Plunger	Moves reciprocally to draw and compress fuel.
Suction Valve		Prevents reverse flow of compressed fuel into the SCV.
Delivery Valve		Prevents reverse flow from the rail of the fuel pumped from the plunger.
Fuel Temperature Sensor		Detects the fuel temperature.

- The HP4 supply pump component parts and functions are basically the same as for the HP3. The explanations below only cover those points on which the HP4 differs from the HP3. For other parts, see the appropriate item in the explanation of the HP3.

Pump Unit (Eccentric Cam, Ring Cam, Plunger)

- A triangular ring cam is installed on the eccentric cam on the drive shaft, and three plungers are installed to the ring cam at intervals of 120°.

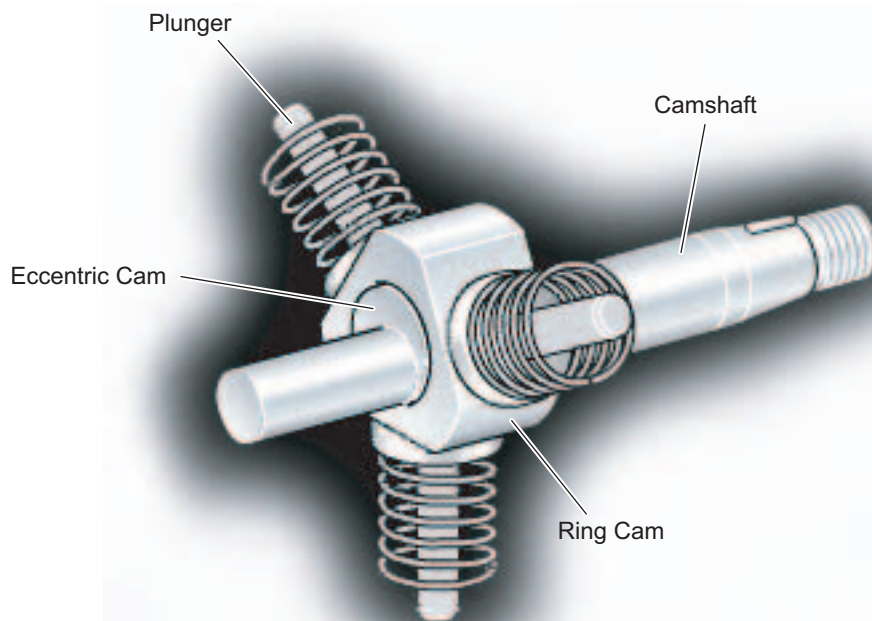

Q000851E

- Because the rotation of the camshaft makes the eccentric cam rotate eccentrically, the ring cam follows this and this moves the three plungers reciprocally. (The ring cam itself does not rotate.)

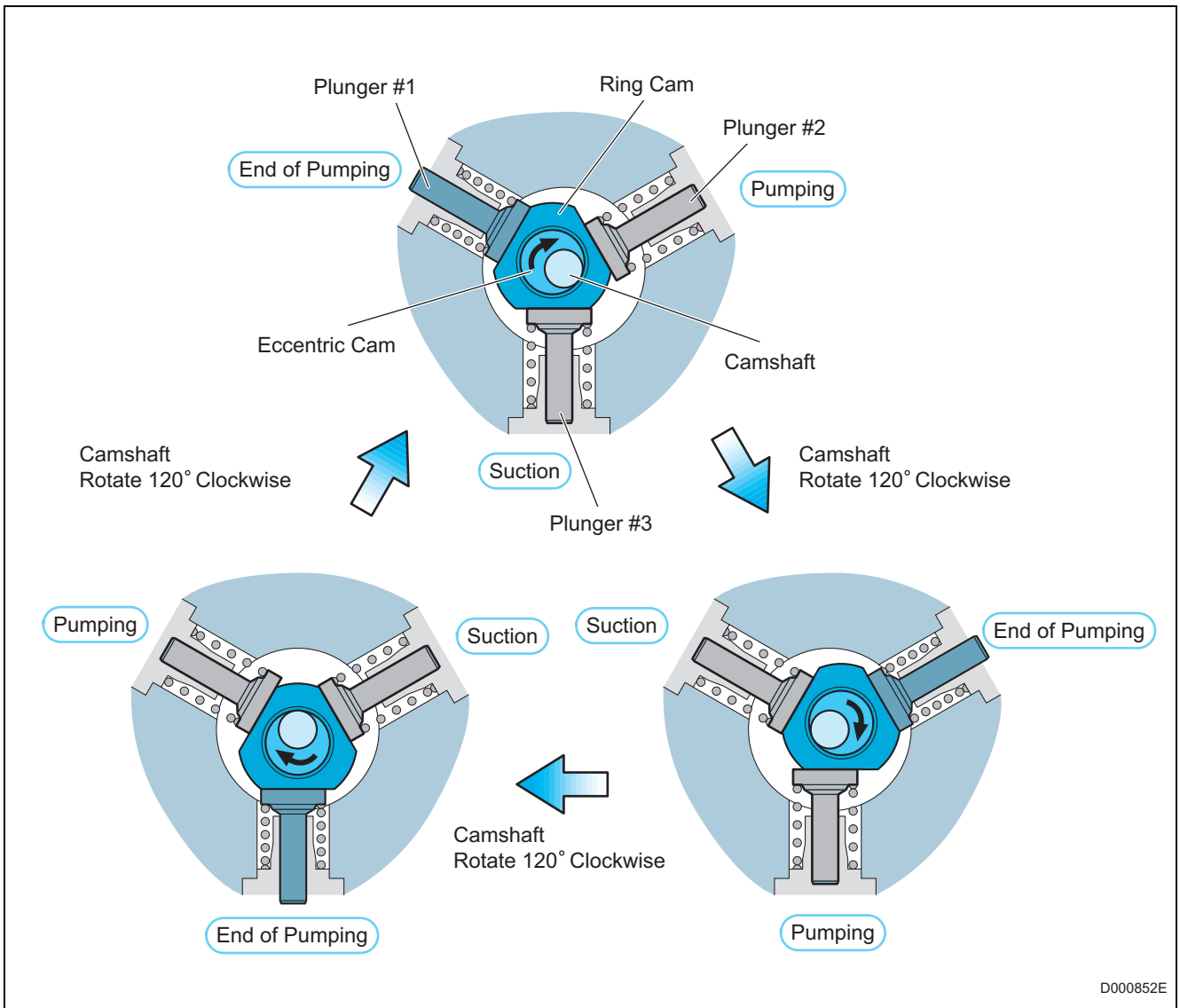

(4) Supply Pump Operation

Supply Pump Overall Fuel Flow

- The fuel is suctioned by the feed pump from the fuel tank and sent to the SCV. At this time, the regulating valve adjusts the fuel pressure to below a certain level. The fuel sent from the feed pump has the required discharge quantity adjusted by the SCV, and enters the pump unit through the suction valve. The fuel pumped by the pump unit is pumped through the delivery valve to the rail.

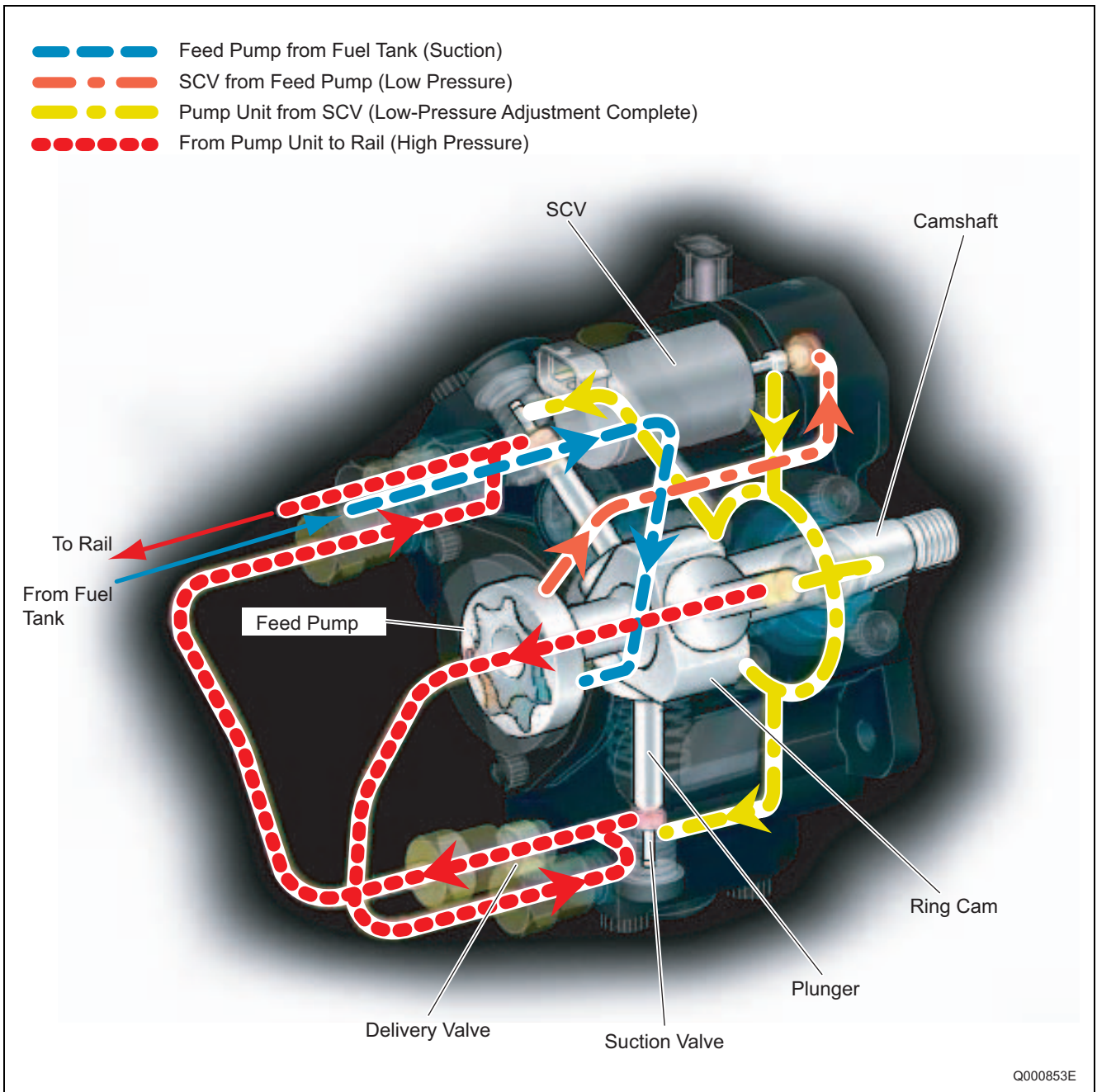

Operation

- The discharge quantity is controlled by the SCV. As with the HP3, the valve opening is adjusted by duty ratio control. The only difference from the HP3 is the shape of the pump unit. Operation and control are basically the same. For details on operation and control, see the explanation of the HP3.

4. RAIL DESCRIPTION

4.1 Rail Functions and Composition

- The function of the rail is to distribute fuel pressurized by the supply pump to each cylinder injector.
- The shape of the rail depends on the model and the component parts vary accordingly.
- The component parts are the rail pressure sensor (Pc sensor), pressure limiter, and for some models a flow damper and pressure discharge valve.

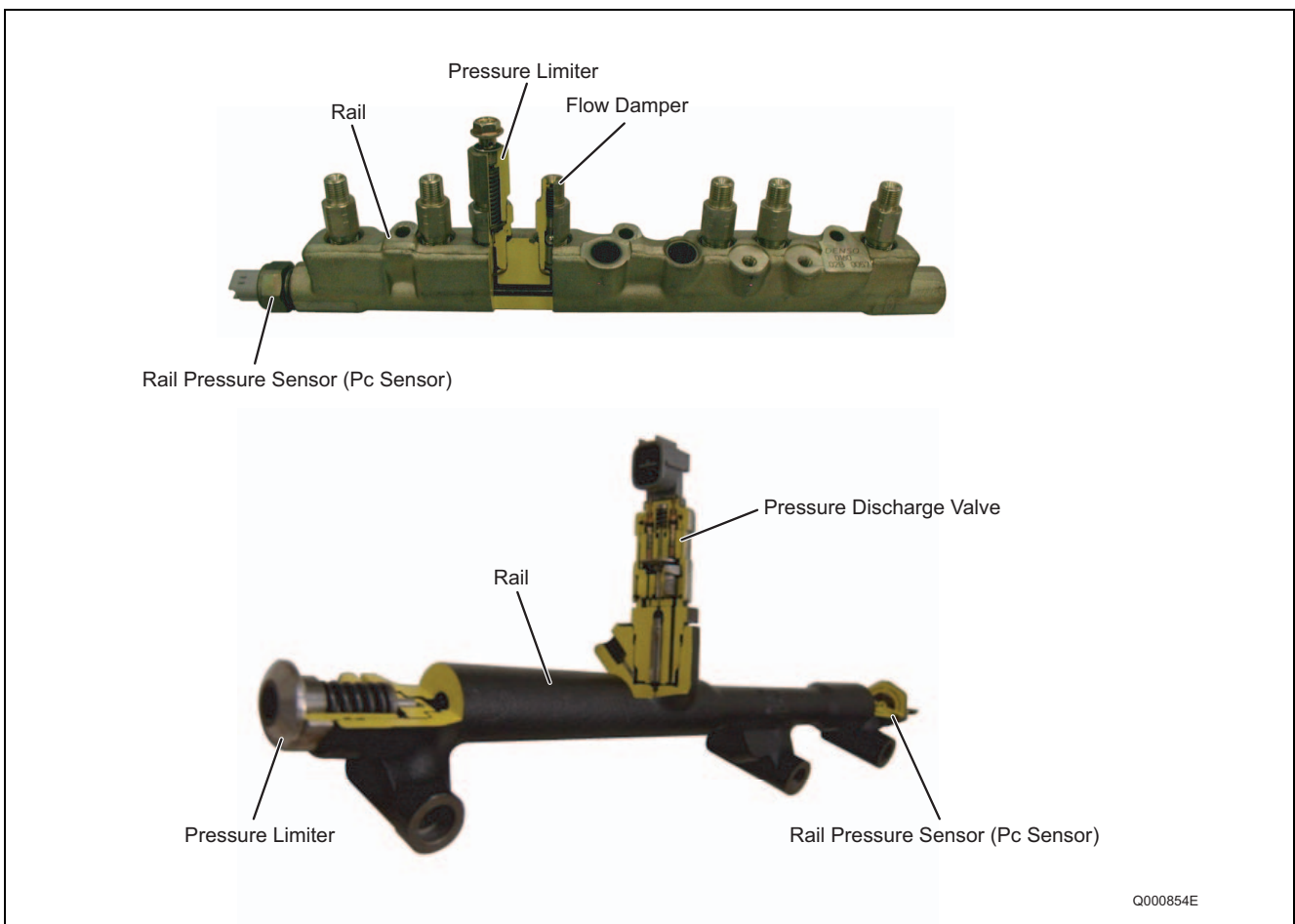

4.2 Component Part Construction and Operation

Component Parts	Functions
Rail	Stores pressurized fuel that has been pumped from the supply pump and distributes the fuel to each cylinder injector.
Pressure Limiter	Opens the valve to release pressure if the pressure in the rail becomes abnormally high.
Rail Pressure Sensor (Pc Sensor)	Detects the fuel pressure in the rail.
Flow Damper	Reduces the pressure pulsations of fuel in the rail. If fuel flows out excessively, the damper closes the fuel passage to prevent further flow of fuel. Mostly used with engines for large vehicles.
Pressure Discharge Valve	Controls the fuel pressure in the rail. Mostly used with engines for passenger cars.

(1) Pressure Limiter

- The pressure limiter opens to release the pressure if abnormally high pressure is generated. If pressure within the rail becomes abnormally high, the pressure limiter operates (opens). It resumes operation (closes) after the pressure falls to a certain level. Fuel released by the pressure limiter returns to the fuel tank.

< NOTE >

The operating pressures for the pressure limiter depend on the vehicle model and are approximately 140-230MPa for the valve opening pressure, and approximately 30-50MPa for the valve closing pressure.

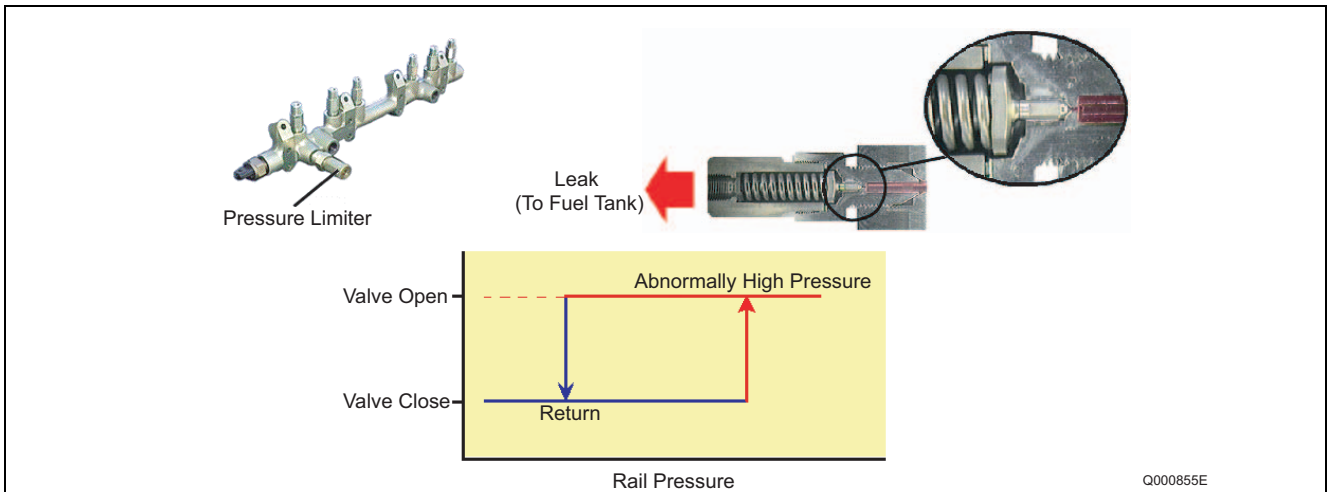

(2) Rail Pressure Sensor (Pc Sensor)

- The rail pressure sensor (Pc sensor) is installed on the rail. It detects the fuel pressure in the rail and sends a signal to the engine ECU. This is a semi-conductor sensor that uses the piezo-electric effect of the electrical resistance varying when pressure is applied to a silicon element.

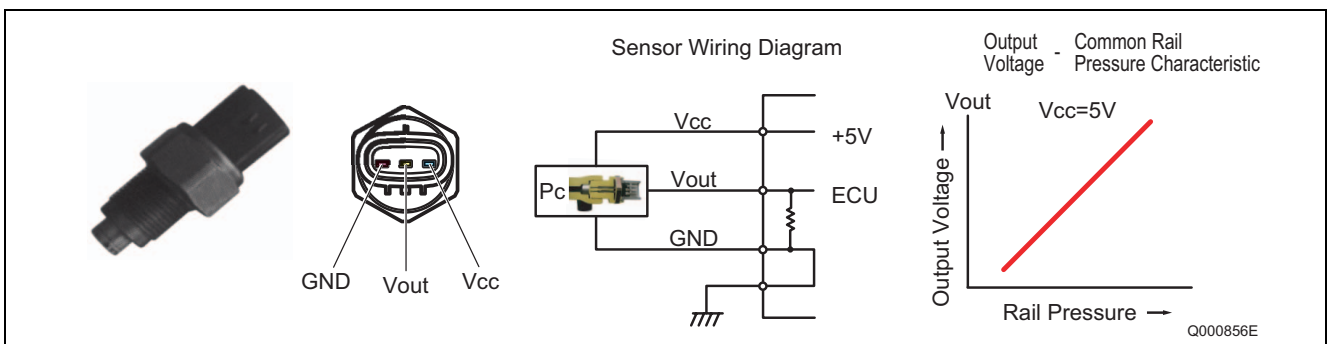

- There are also rail pressure sensors that have dual systems to provide a backup in case of breakdown. The output voltage is offset.

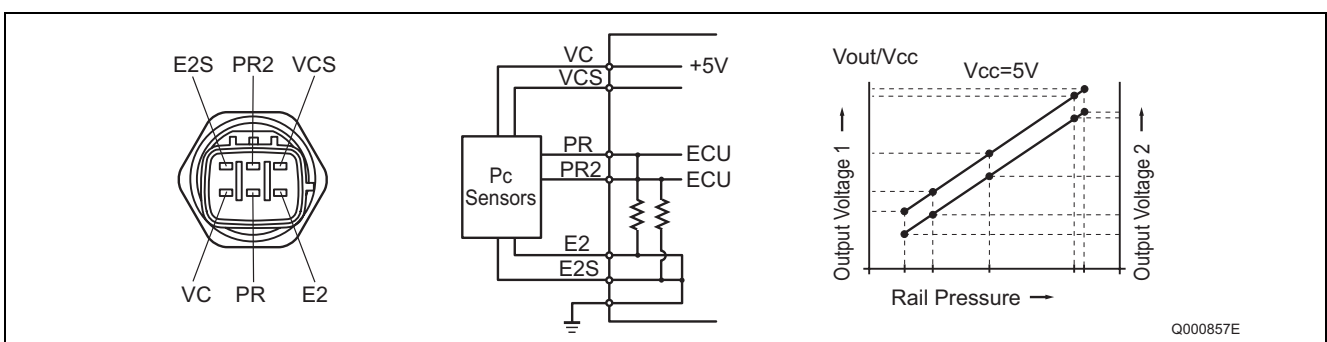

(3) Flow Damper

- The flow damper reduces the pressure pulsations of the fuel in the pressurized pipe and supplies fuel to the injectors at a stabilized pressure. The flow damper also prevents abnormal discharge of fuel by shutting off the fuel passage in the event of excess fuel discharge, for example due to fuel leaking from an injection pipe or injector. Some flow dampers combine a piston and ball, and some have only a piston.

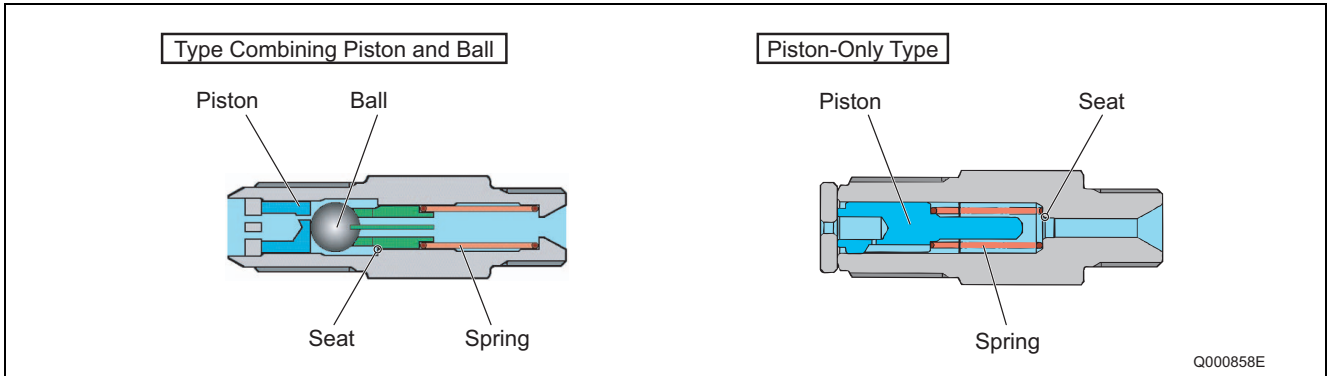

Operation of Piston-and-Ball Type

- When a pressure pulse occurs in a high-pressure pipe, the resistance of it passing through the orifice disrupts the balance between the rail side and injector side pressures, so the piston and ball move to the injector side, absorbing the pressure pulse. With normal pressure pulses, since the rail side and injector side pressures are soon balanced, the piston and ball are pushed back to the rail side by the spring. If there is an abnormal discharge, for example due to an injector side fuel leak, the amount of fuel passing through the orifice cannot be balanced out and the piston presses the ball against the seat, so the passage for fuel to the injector is shut off.

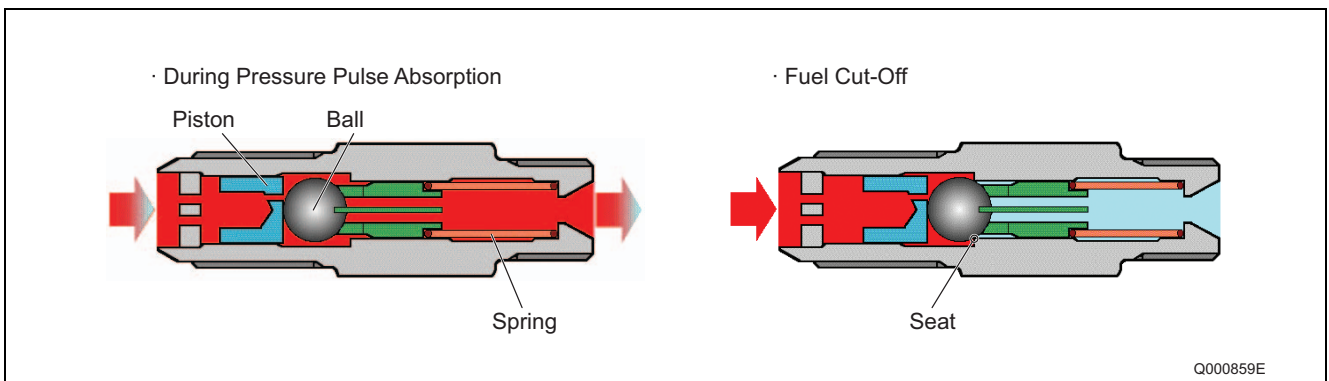

Operation of Piston-Only Type

- The piston contacts the seat directly and the piston shuts off the fuel passage directly. Operation is the same as for the piston-and-ball type.

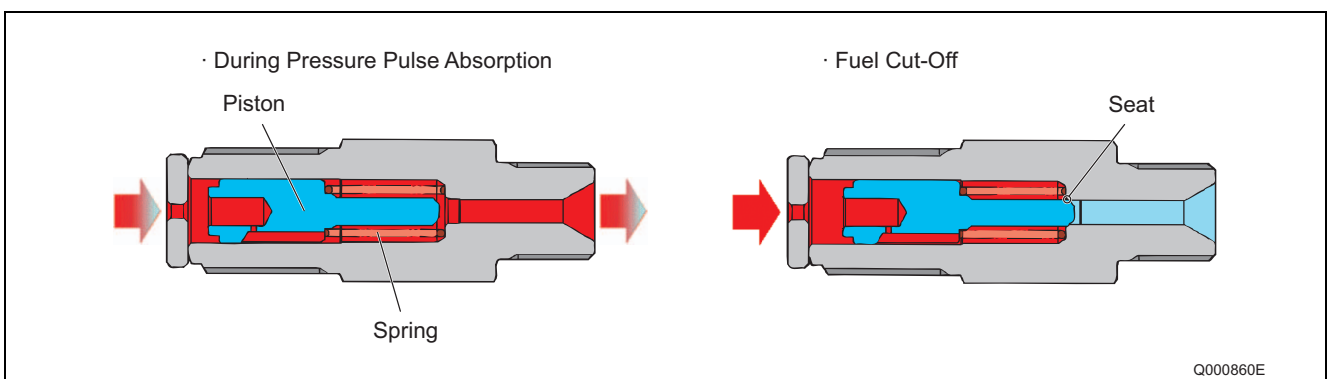

(4) Pressure Discharge Valve

- The pressure discharge valve controls the fuel pressure in the rail. When rail fuel pressure exceeds the target injection pressure, or when the engine ECU judges that rail fuel pressure exceeds the target value, the pressure discharge valve solenoid coil is energized. This opens the pressure discharge valve passage, allowing fuel to leak back to the fuel tank, and reducing rail fuel pressure to the target pressure.

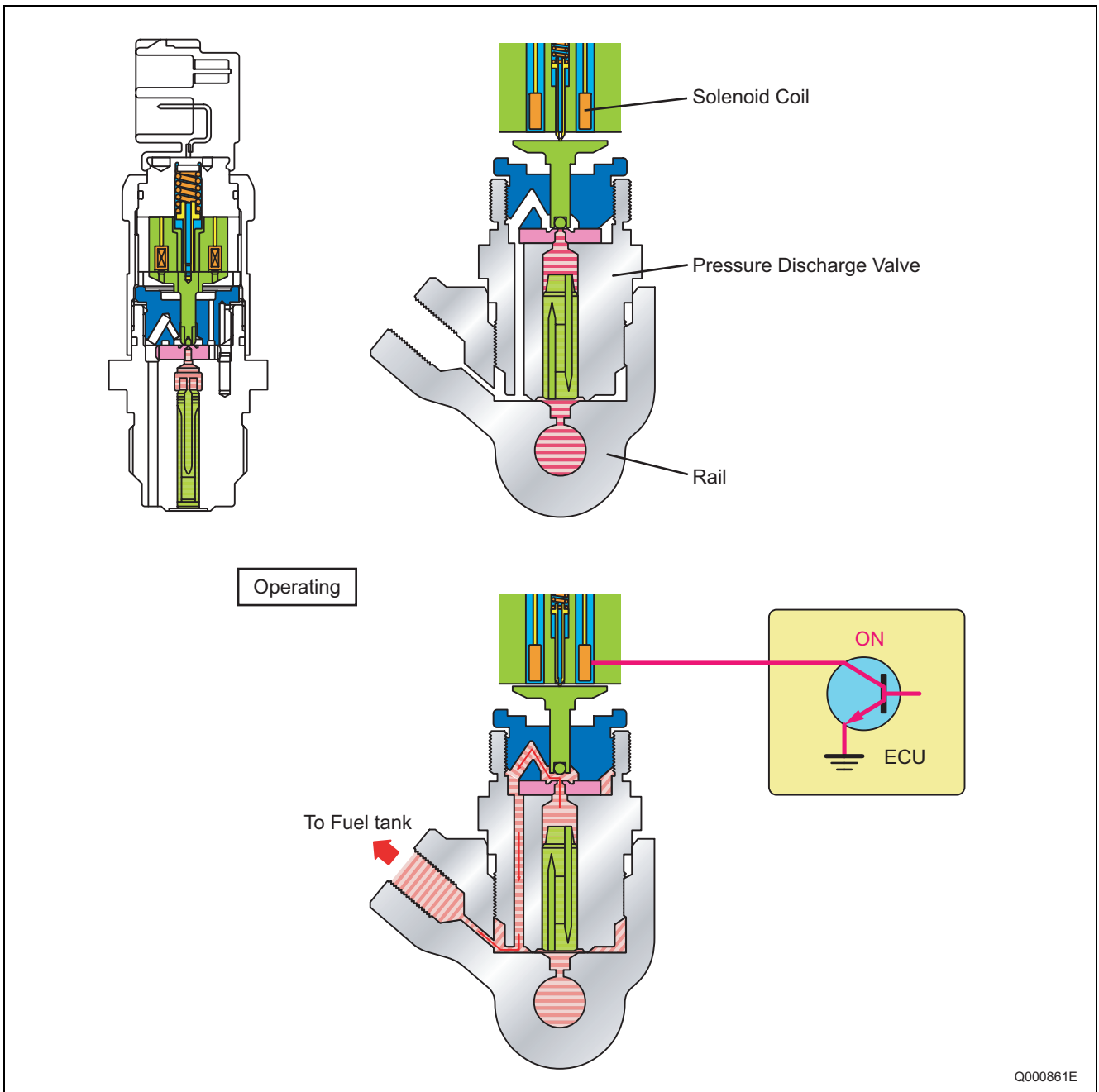

5. INJECTOR DESCRIPTION

5.1 General Description

- The injector injects the pressurized fuel in the rail into the engine combustion chamber at the optimal injection timing, injection quantity, injection rate, and injection pattern, in accordance with signals from the ECU.
- Injection is controlled using a TWV (Two-Way Valve) and orifice. The TWV controls the pressure in the control chamber to control the start and end of injection. The orifice controls the injection rate by restraining the speed at which the nozzle opens.
- The command piston opens and closes the valve by transmitting the control chamber pressure to the nozzle needle.
- When the nozzle needle valve is open, the nozzle atomizes the fuel and injects it.
- There are three types of injectors: the X1, X2, and G2.

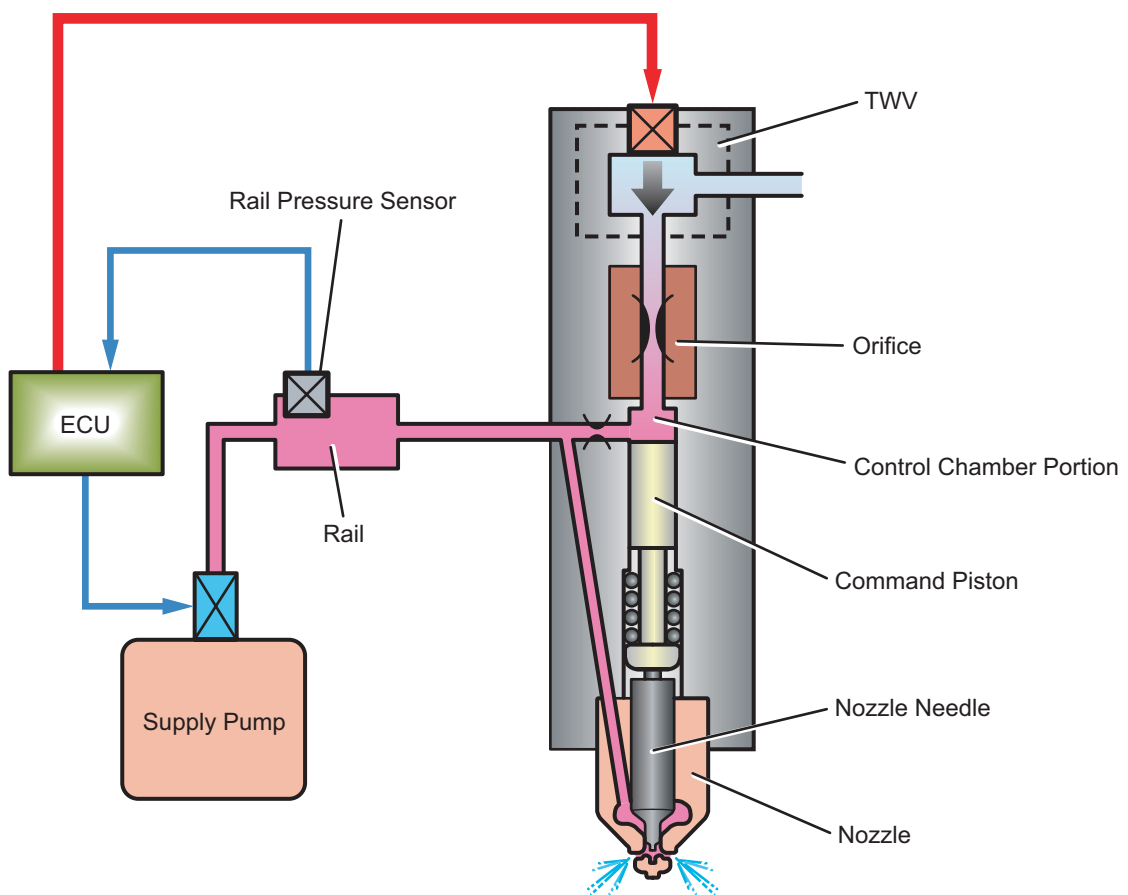

5.2 Injector Construction and Features

- The injector consists of a nozzle similar to the conventional "nozzle & nozzle holder", an orifice that controls the injection rate, the command piston, and a TWV (two-way solenoid valve). The basic construction is the same for the X1, X2, and G2 types.

(1) X1 Type

- Precision control is attained through electronic control of the injection. The TWV comprises two valves: the inner valve (fixed) and the outer valve (movable).

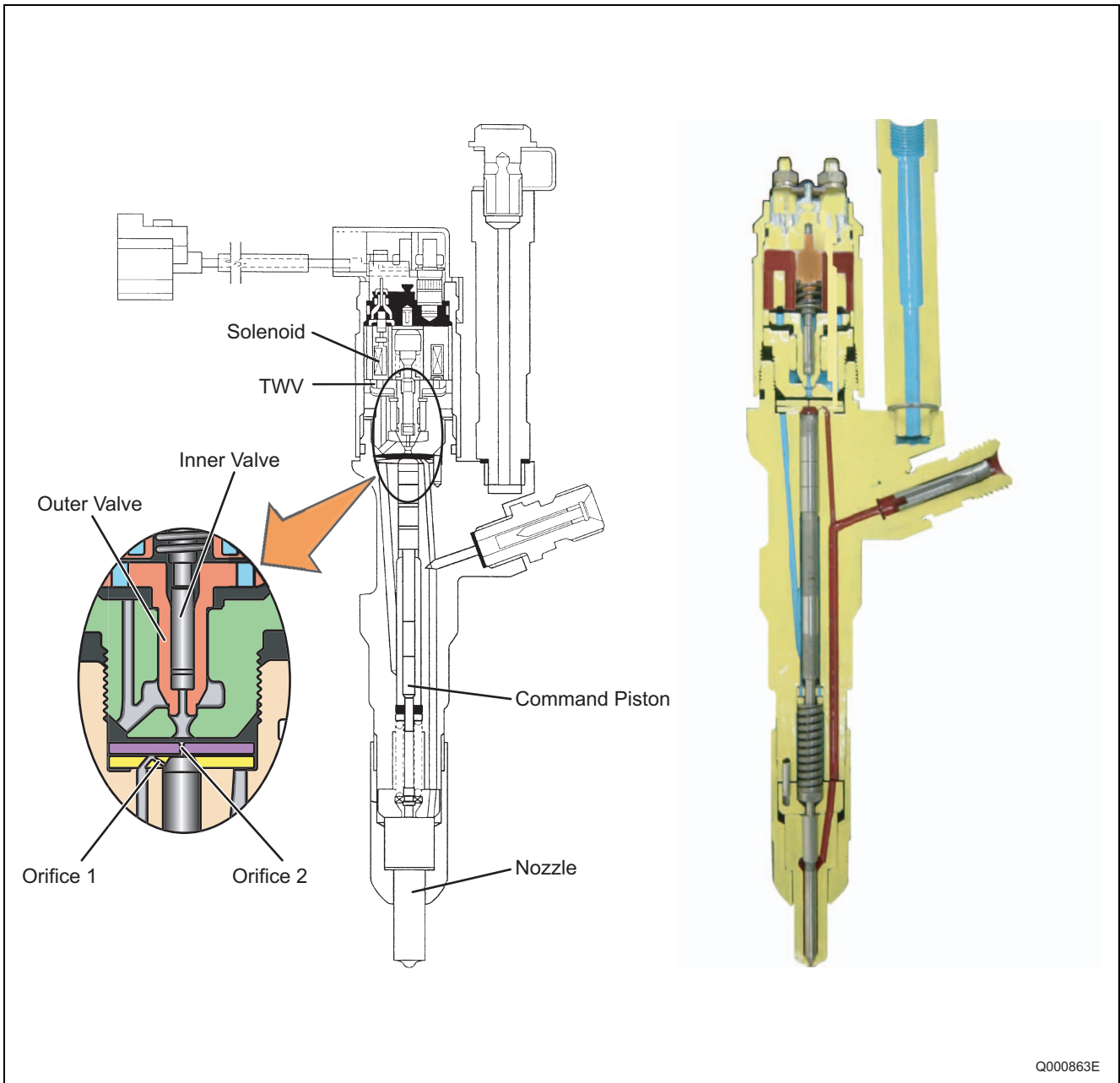

(2) X2 Type

- By reducing the injector actuation load, the injector has been made more compact and energy efficient, and its injection precision has been improved. The TWV directly opens and closes the outlet orifice.

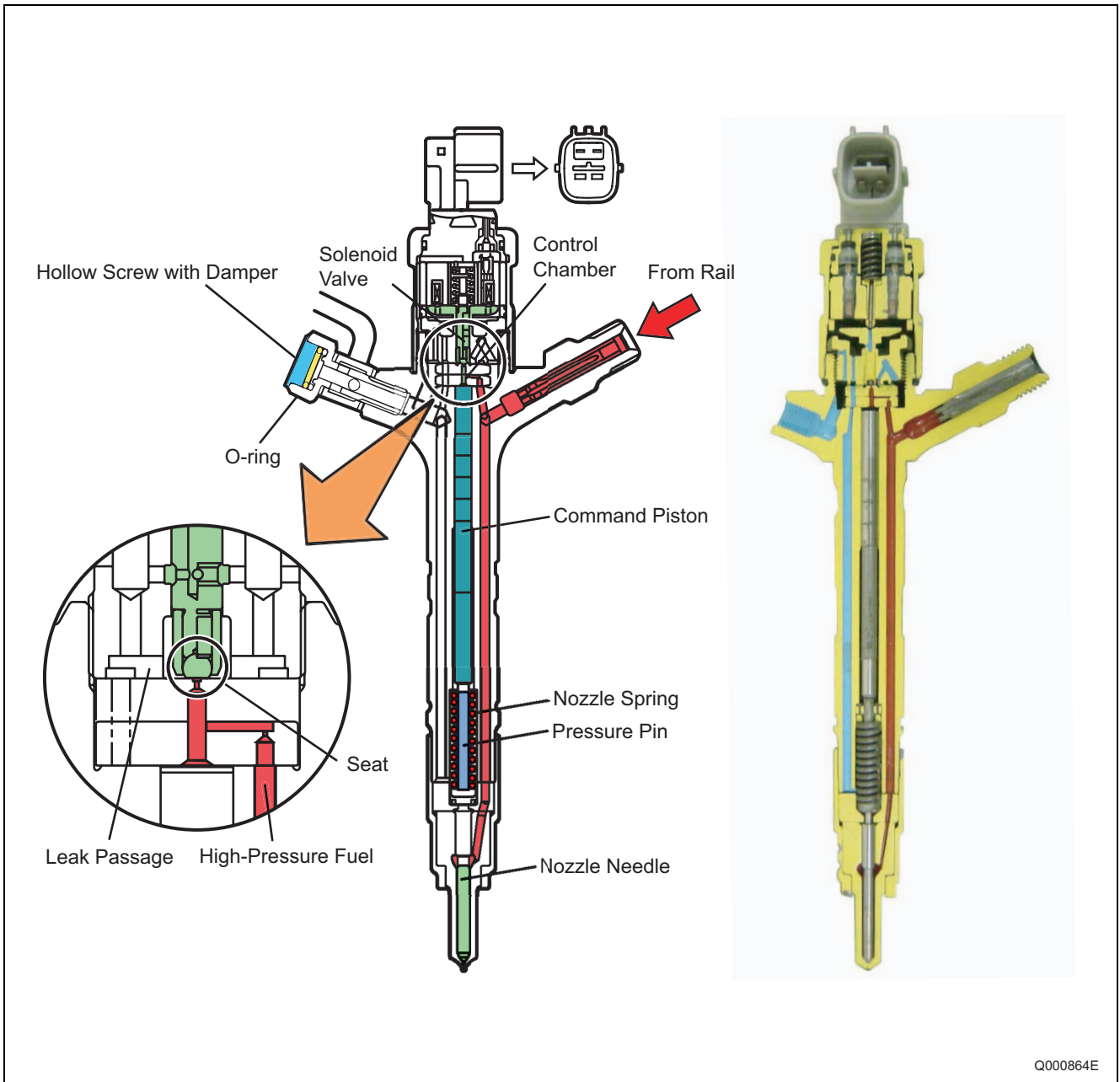

(3) G2 Type

- To ensure high pressure, the G2 type has improved pressure strength, sealing performance and pressure wear resistance. It also has improved high-speed operability, enabling higher-precision injection control and multi-injection.

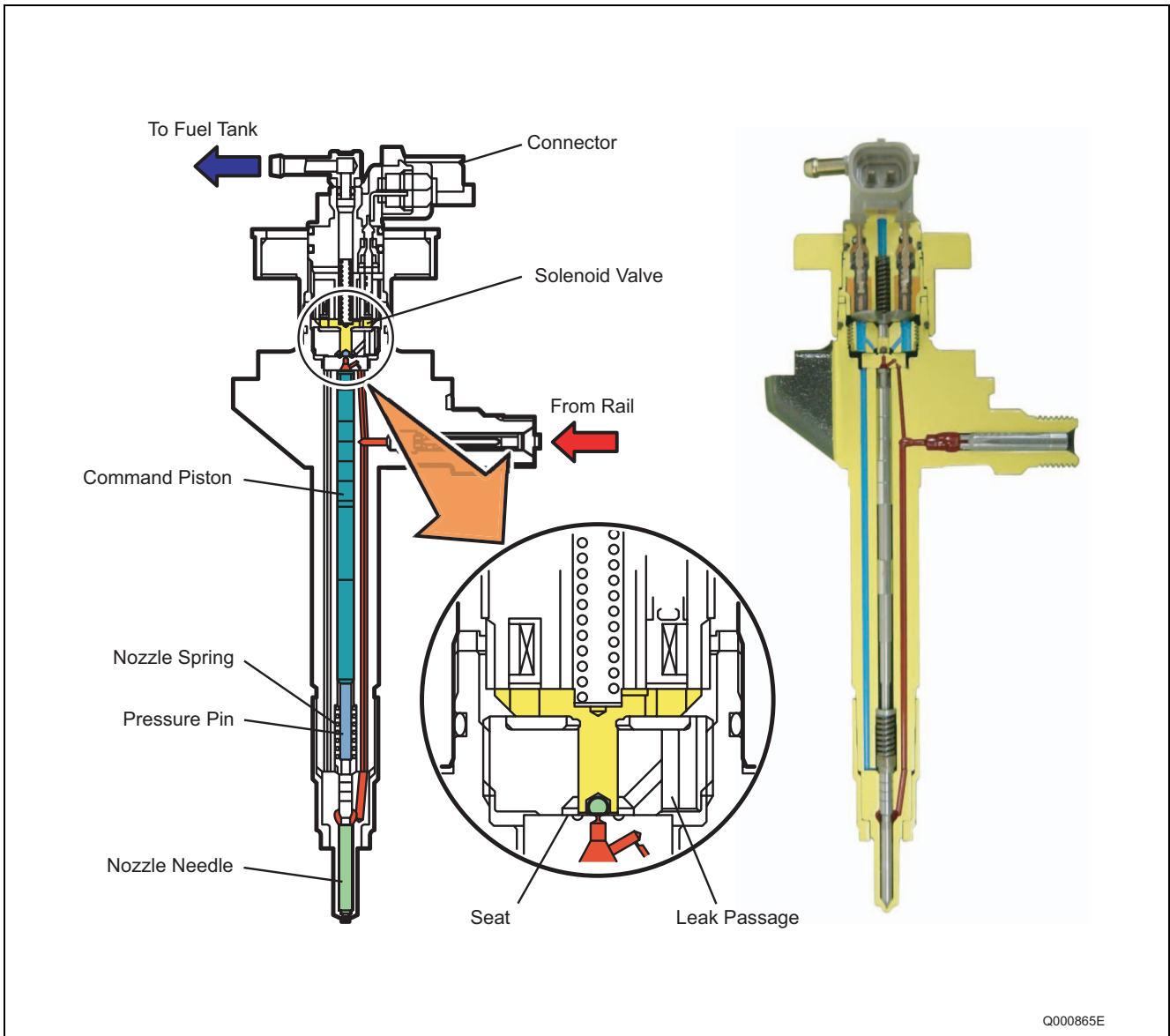

< NOTE >

Multi-injection means that for the purpose of reducing exhaust gas emissions and noise, the main injection is accomplished with one to five injections of fuel without changing the injection quantity.

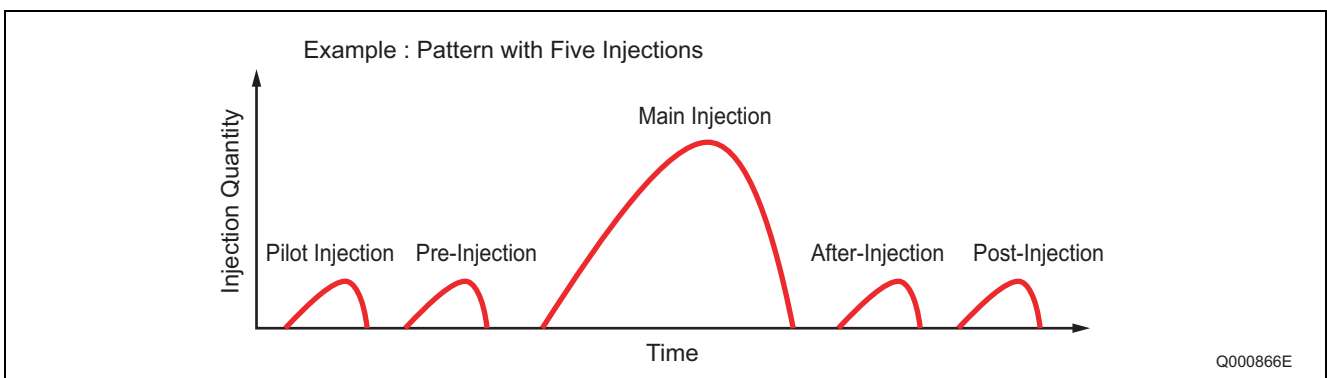

5.3 Injector Operation

- The injector controls injection through the fuel pressure in the control chamber. The TWV executes leak control of the fuel in the control chamber to control the fuel pressure within the control chamber. The TWV varies with the injector type.

Non-Injection

- When the TWV is not energized, the TWV shuts off the leak passage from the control chamber, so the fuel pressure in the control chamber and the fuel pressure applied to the nozzle needle are both the same rail pressure. The nozzle needle thus closes due to the difference between the pressure-bearing surface area of the command piston and the force of the nozzle spring, and fuel is not injected. For the X1 type, the leak passage from the control chamber is shut off by the outer valve being pressed against the seat by the force of the spring, and the fuel pressure within the outer valve. For the X2/G2 types, the control chamber outlet orifice is closed directly by the force of the spring.

Injection

- When TWV energization starts, the TWV valve is pulled up, opening the leak passage from the control chamber. When this leak passage opens, the fuel in the control chamber leaks out and the pressure drops. Because of the drop in pressure within the control chamber, the pressure on the nozzle needle overcomes the force pressing down, the nozzle needle is pushed up, and injection starts. When fuel leaks from the control chamber, the flow quantity is restricted by the orifice, so the nozzle opens gradually. The injection rate rises as the nozzle opens. As current continues to be applied to the TWV, the nozzle needle eventually reaches the maximum amount of lift, which results in the maximum injection rate. Excess fuel is returned to the fuel tank through the path shown.

End of Injection

- When TWV energization ends, the valve descends, closing the leak passage from the control chamber. When the leak passage closes, the fuel pressure within the control chamber instantly returns to the rail pressure, the nozzle closes suddenly, and injection stops.

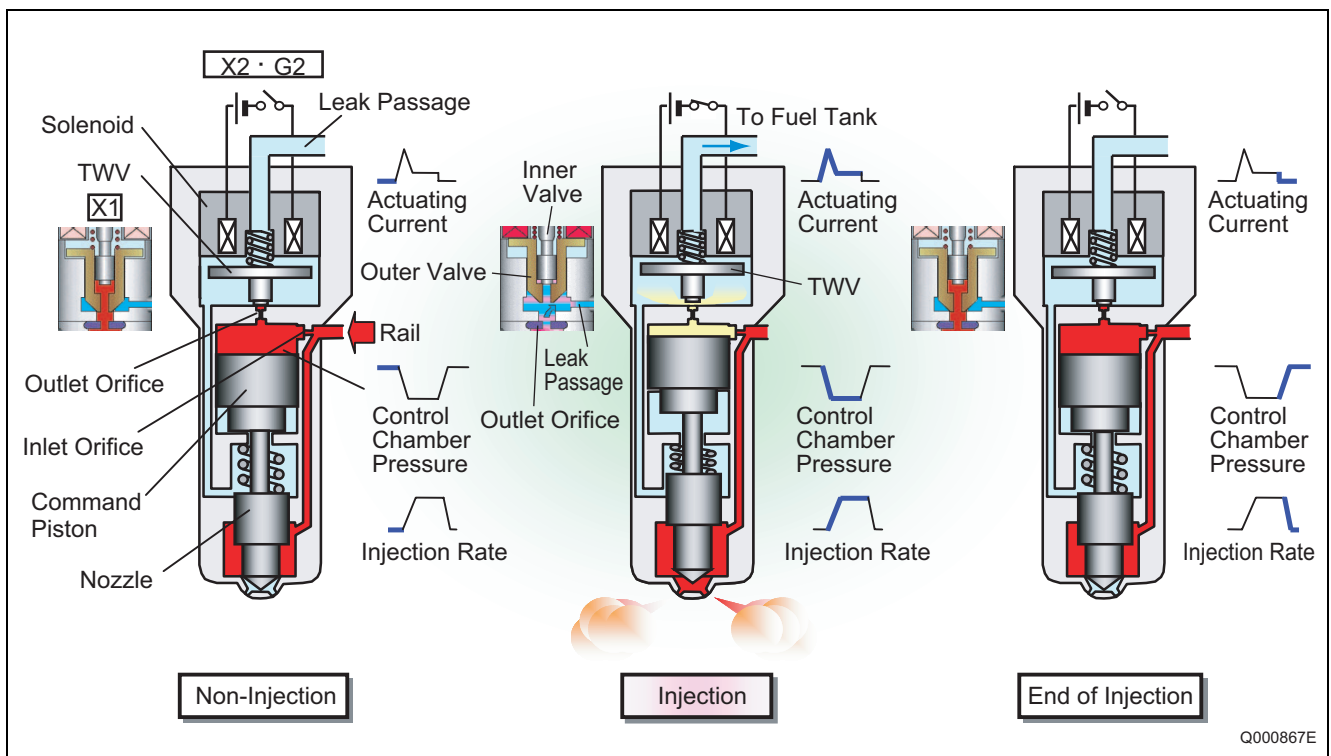

5.4 Injector Actuation Circuit

- In order to improve injector responsiveness, the actuation voltage has been changed to high voltage, speeding up both solenoid magnetization and the response of the TWV. The EDU or the charge circuit in the ECU raises the respective battery voltage to approximately 110V, which is supplied to the injector by signal from the ECU to actuate the injector.

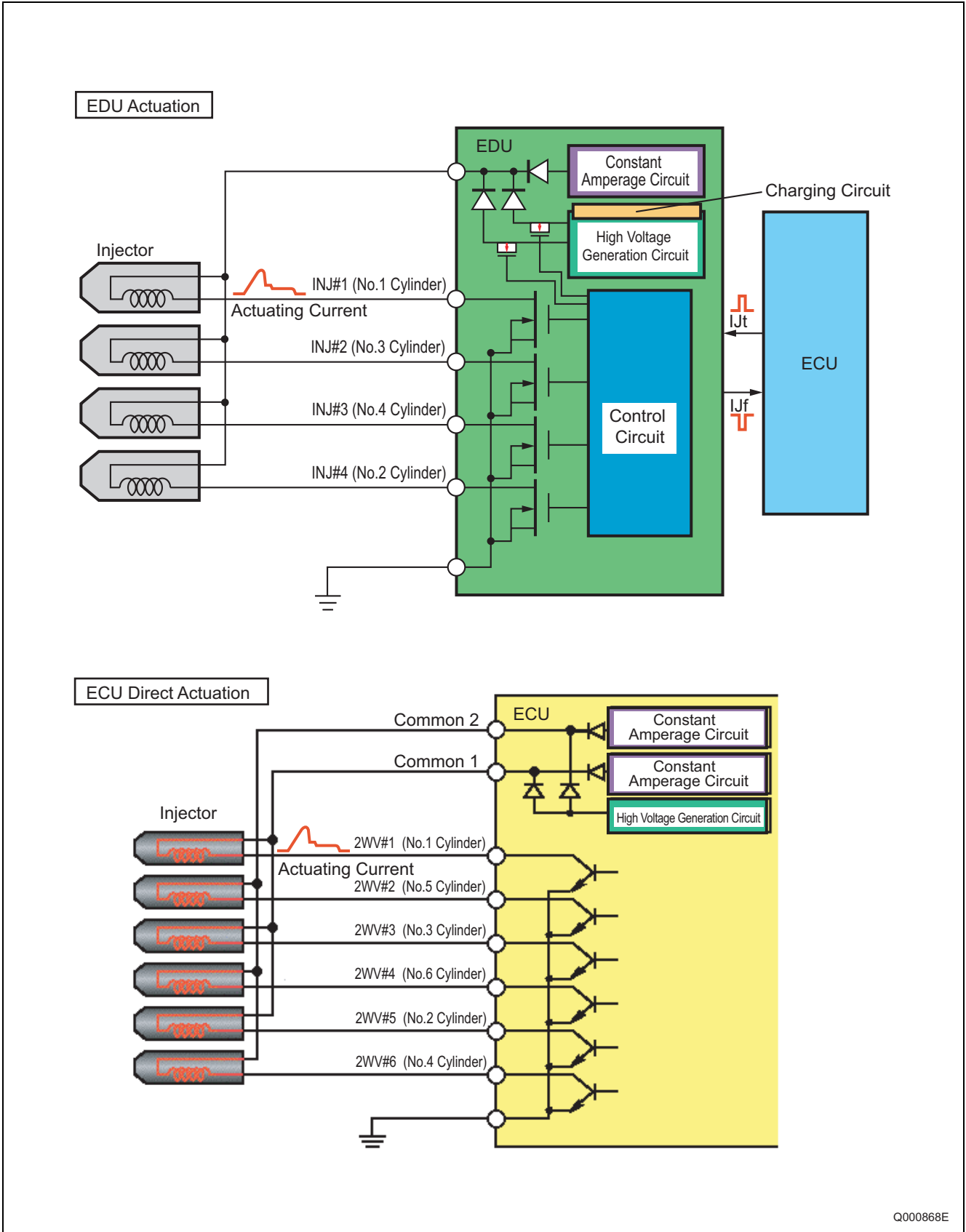

5.5 Other Injector Component Parts

(1) Hollow Screw with Damper

- The hollow screw with damper enhances injection quantity accuracy, by reducing the back-pressure pulsations (pressure fluctuations) of the leak fuel. In addition, it minimizes the back-pressure dependence (the effect of the pressure in the leak pipe changing the injection quantity even though the injection command is the same) of the fuel in the leak pipe.

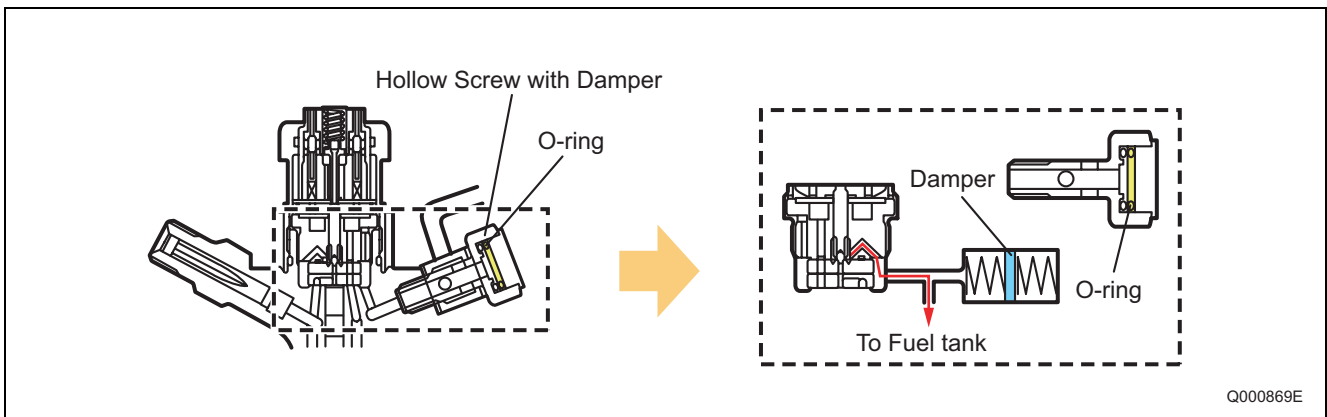

(2) Connector with Correction Resistor

- The connector with correction resistor has a built-in correction resistor in the connector section to minimize injection quantity variation among the cylinders.

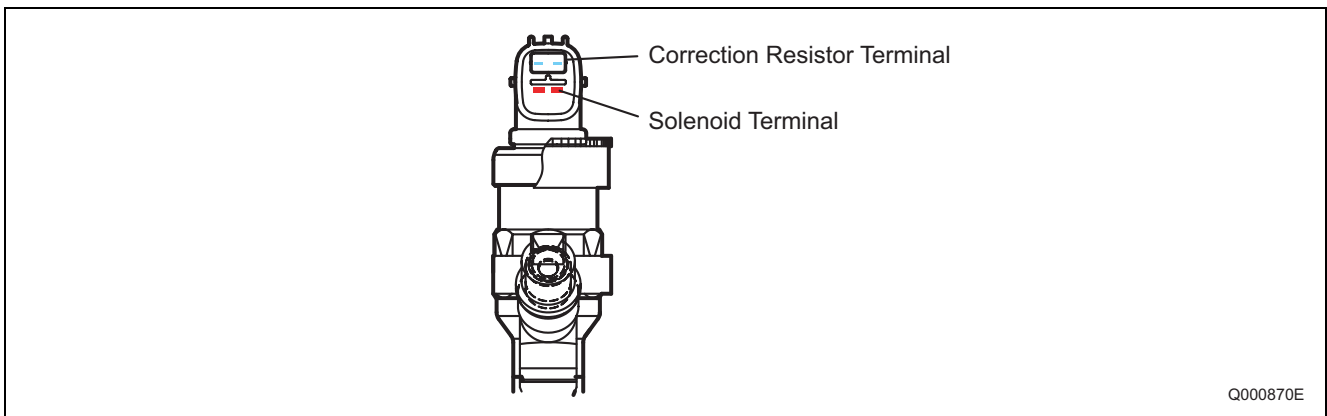

(3) Injector with QR Codes

- QR (Quick Response) codes have been adopted to enhance correction precision. The QR code, which contains the correction data of the injector, is written to the engine ECU. QR codes have resulted in a substantial increase in the number of fuel injection quantity correction points, greatly improving injection quantity precision.

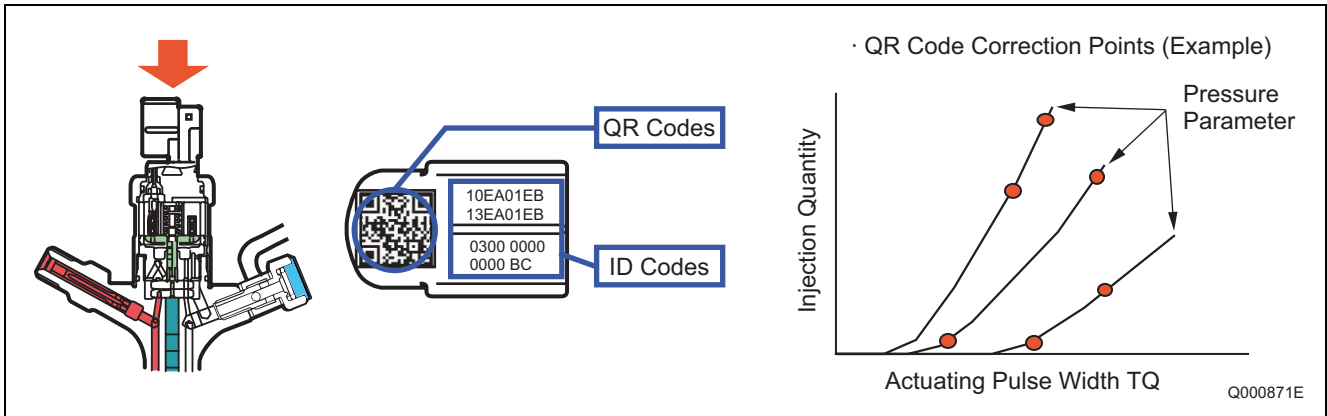

< NOTE >

QR codes are a new two-dimensional code that was developed by DENSO. In addition to injection quantity correction data, the code contains the part number and the product number, which can be read at extremely high speeds.

Handling Injectors with QR Codes (Reference)

- Injectors with QR codes have the engine ECU recognize and correct the injectors, so when an injector or the engine ECU is replaced, it is necessary to register the injector's ID code in the engine ECU.

Replacing the Injector

- It is necessary to register the ID code of the injector that has been replaced in the engine ECU.

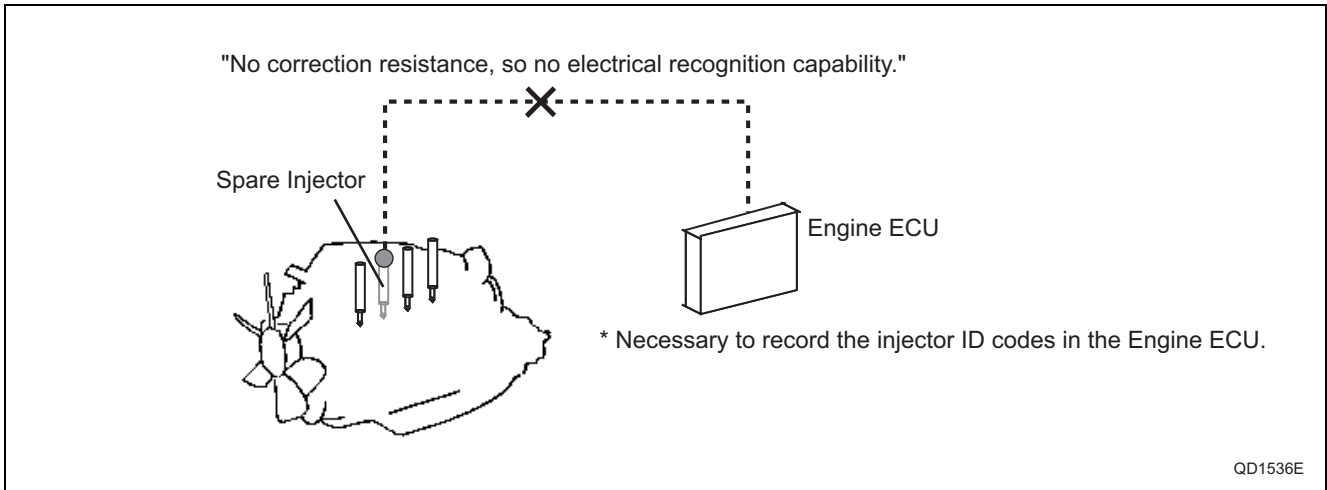
**Replacing the Engine ECU**

- It is necessary to register the ID codes of all the vehicle injectors in the engine ECU.

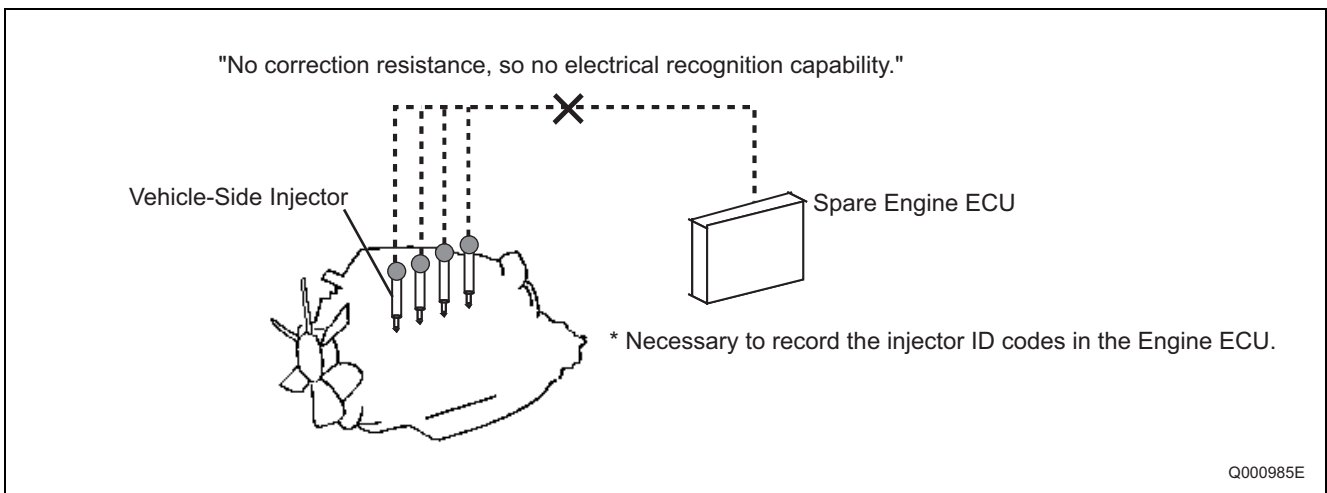

6. DESCRIPTION OF CONTROL SYSTEM COMPONENTS

6.1 Engine Control System Diagram (Reference)

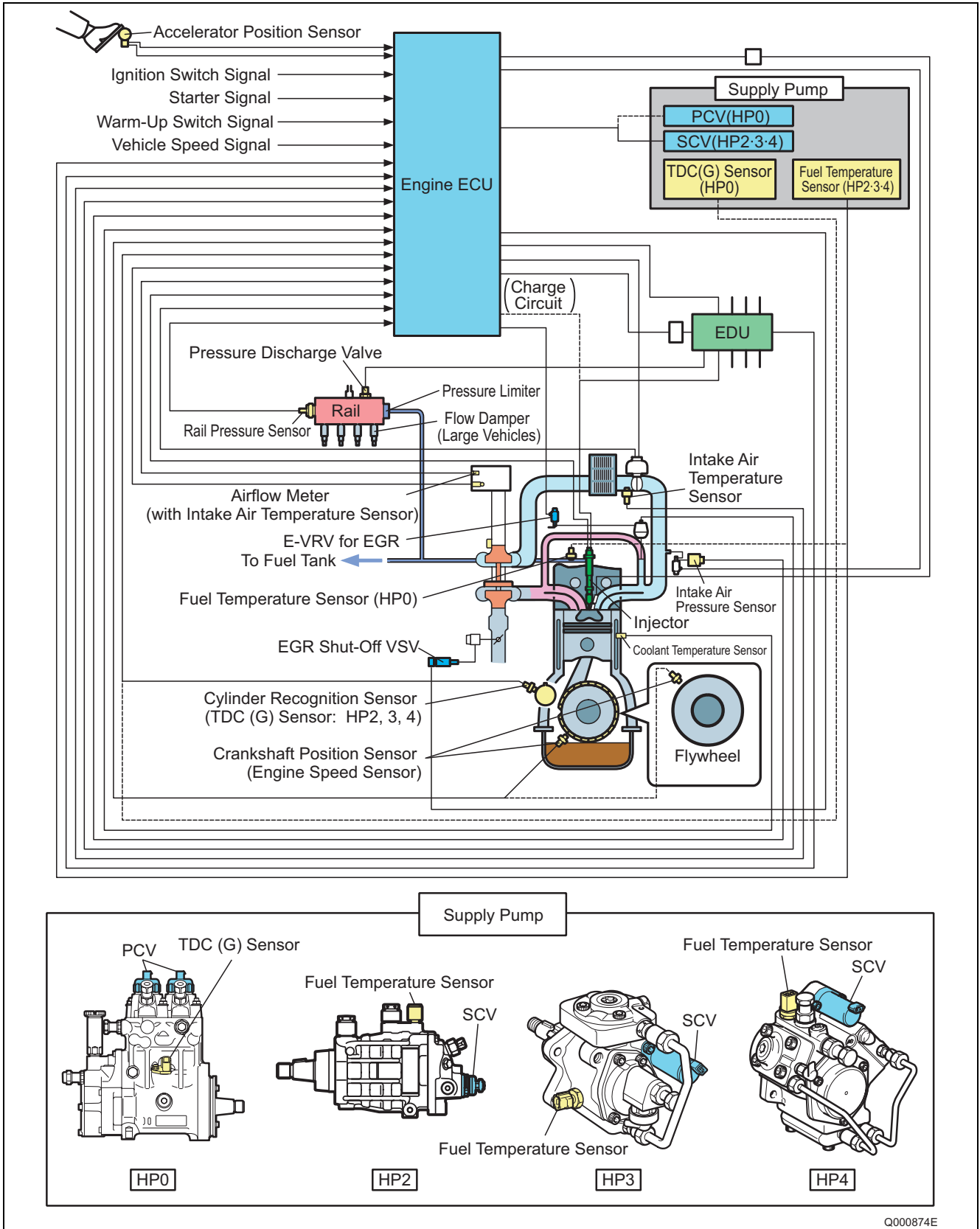

6.2 Engine ECU (Electronic Control Unit)

- The engine ECU constantly ascertains the status of the engine through signals from the sensors, calculates fuel injection quantities etc. appropriate to the conditions, actuates the actuators, and controls to keep the engine in an optimal state. The injectors are actuated by either the EDU or the charge circuit in the engine ECU. This actuation circuit depends on the specifications of the model it is mounted in. The ECU also has a diagnosis function for recording system troubles.

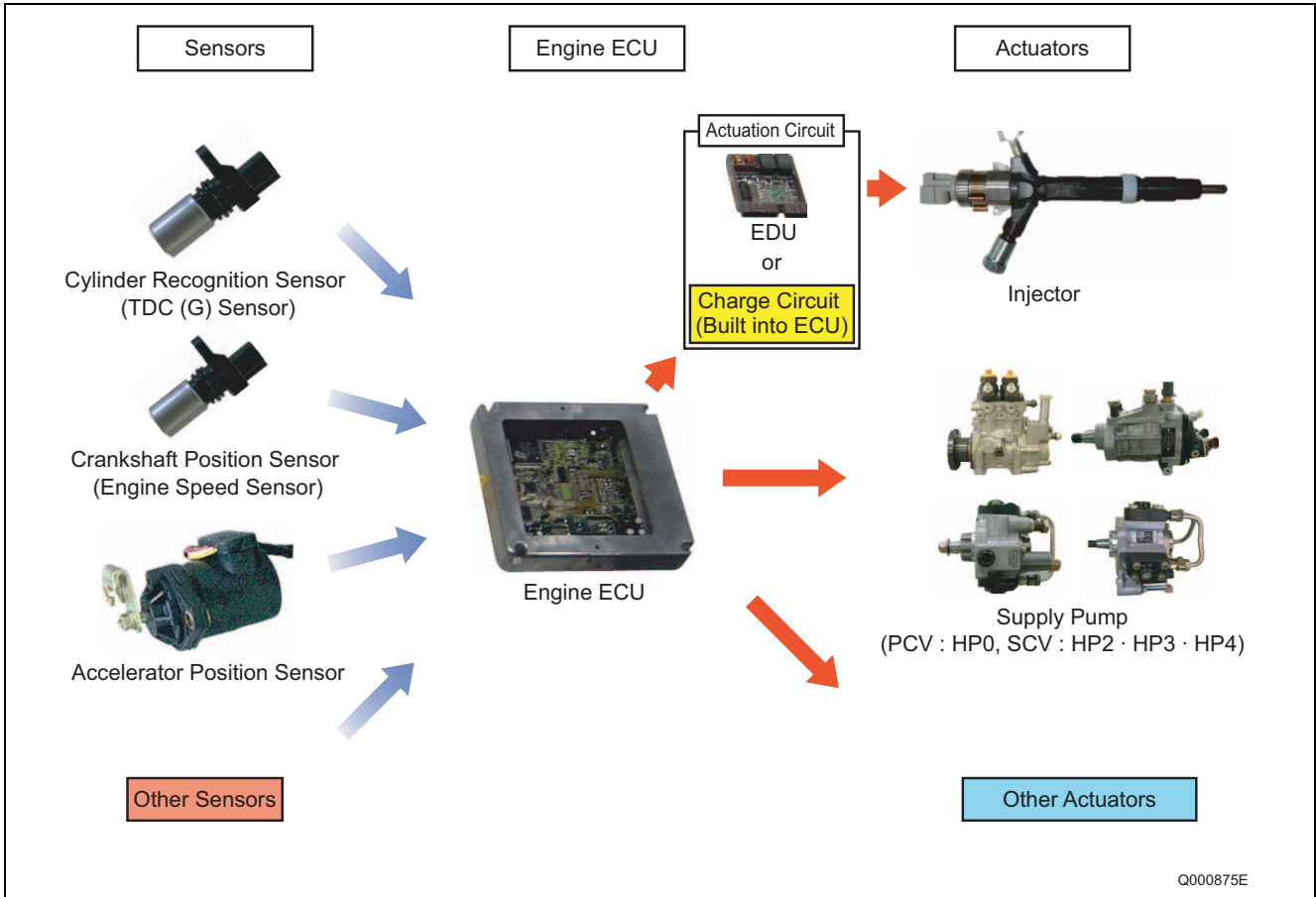

6.3 EDU (Electronic Driving Unit)

(1) General Description

- An EDU is provided to enable high-speed actuation of the injectors. The EDU has a high-voltage generation device (DC/DC converter) and supplies high voltage to the injectors to actuate the injectors at high speed.

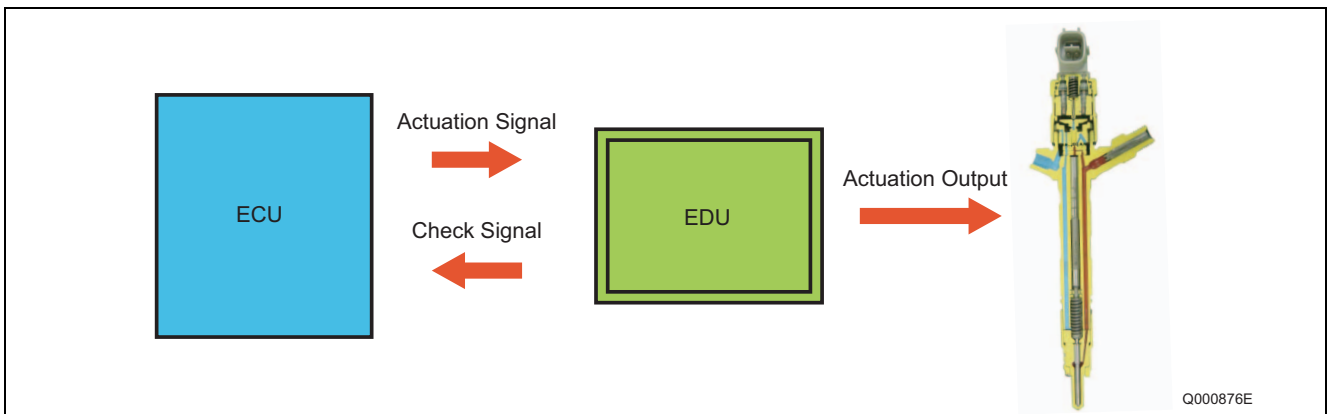

(2) Operation

- The high-voltage generating device in the EDU converts the battery voltage into high voltage. The ECU sends signals to terminals B through E of the EDU in accordance with the signals from the sensors. Upon receiving these signals, the EDU outputs signals to the injectors from terminals H through K. At this time, terminal F outputs the IJf injection verification signal to the ECU.

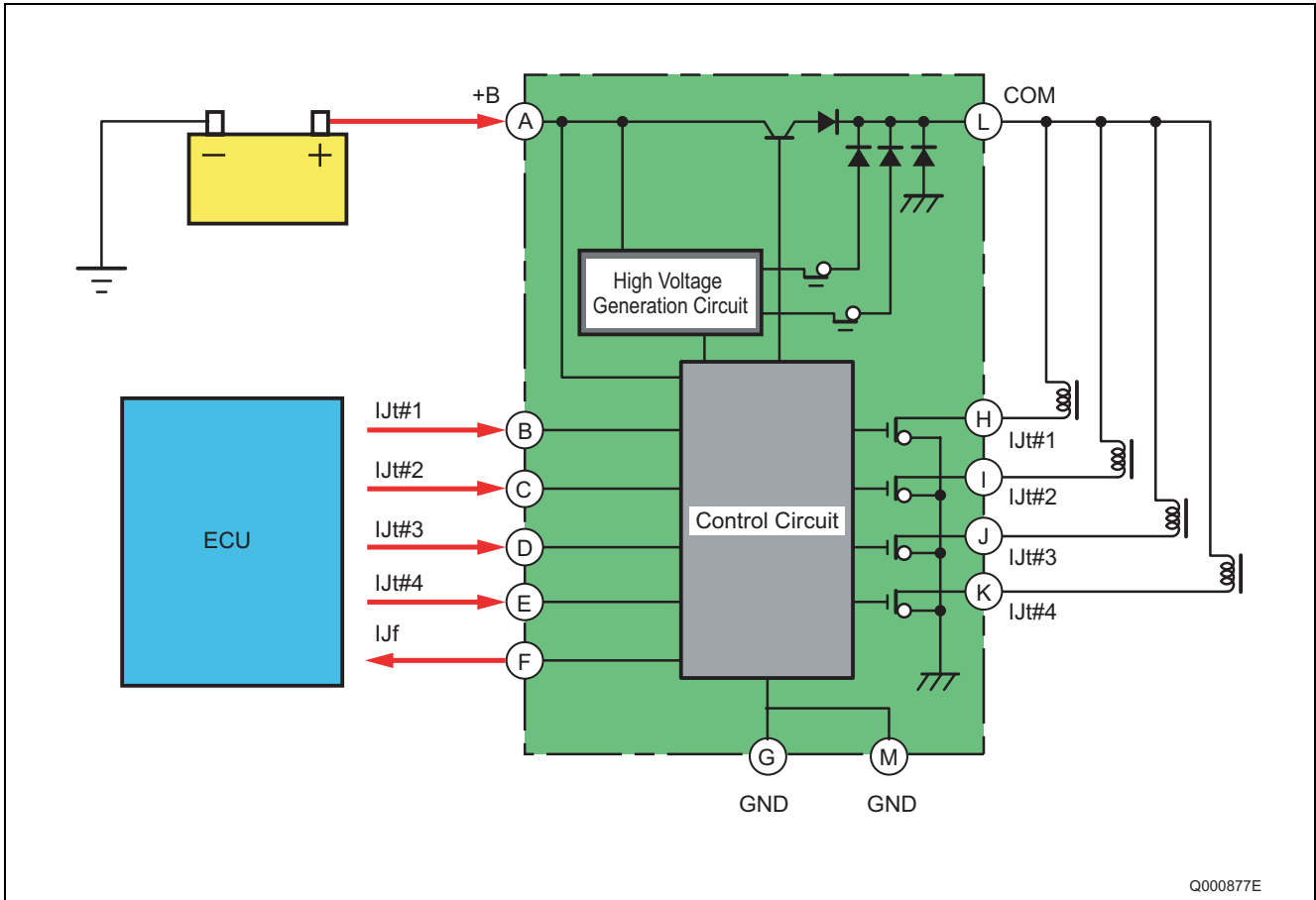

6.4 Various Sensors

Various Sensor Functions

Sensor	Functions
Crankshaft Position Sensor (Engine Speed Sensor)	Detects the crankshaft angle and outputs the engine speed signal.
Cylinder Recognition Sensor (TDC (G) Sensor)	Identifies the cylinders.
Accelerator Position Sensor	Detects the opening angle of the accelerator pedal.
Intake Air Temperature Sensor	Detects the temperature of the intake air after it has passed through the turbo-charger.
Mass Airflow Meter	Detects the flow rate of the intake air. It also contains an intake air temperature sensor that detects the temperature of the intake air (atmospheric temperature).
Coolant Temperature Sensor	Detects the engine coolant temperature.
Fuel Temperature Sensor	Detects the fuel temperature.
Intake Air Pressure Sensor	Detects the intake air pressure.
Atmospheric Pressure Sensor	Detects the atmospheric pressure.

(1) Crankshaft Position Sensor (Engine Speed Sensor) and Cylinder Recognition Sensor {TDC (G) Sensor}

Crankshaft Position Sensor (Engine Speed Sensor)

• The crankshaft position sensor is installed near the crankshaft timing gear or the flywheel. The sensor unit is a MPU (magnetic pickup) type. When the engine speed pulsar gear installed on the crankshaft passes the sensor section, the magnetic field of the coil within the sensor changes, generating AC voltage. This AC voltage is detected by the engine ECU as the detection signal. The number of pulses for the engine speed pulsar depends on the specifications of the vehicle the sensor is mounted in.

Cylinder Recognition Sensor {TDC (G) Sensor}

• The cylinder recognition sensor is installed on the supply pump unit for the HP0 system, but for the HP2, HP3, or HP4 system, it is installed near the supply pump timing gear. Sensor unit construction consists of the MPU type, which is the same as for the crankshaft position sensor, and the MRE (magnetic resistance element) type. For the MRE type, when the pulsar passes the sensor, the magnetic resistance changes and the voltage passing through the sensor changes. This change in voltage is amplified by the internal IC circuit and output to the engine ECU. The number of pulses for the TDC pulsar depends on the specifications of the vehicle the sensor is mounted in.

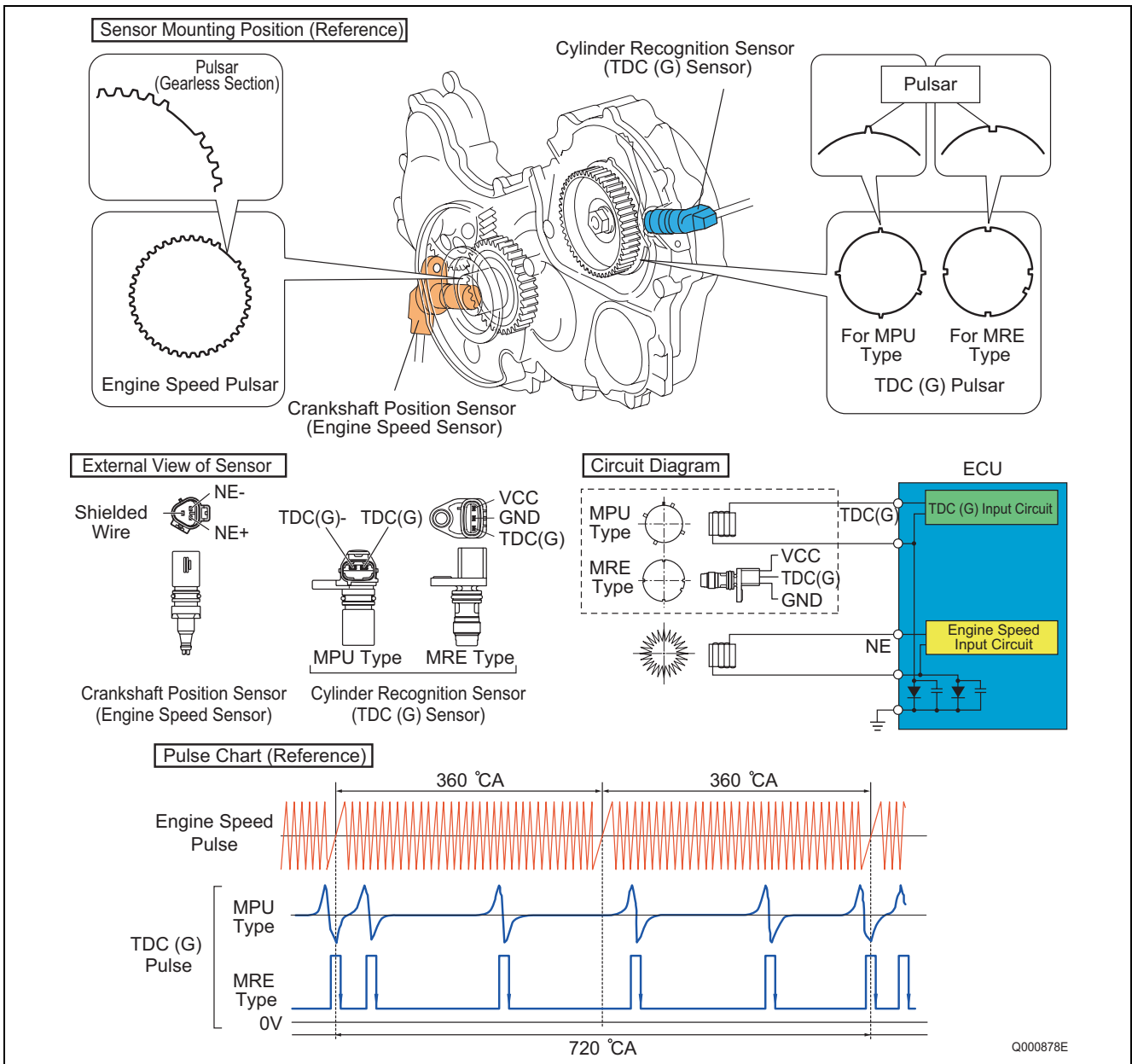

(2) Accelerator Position Sensor

- The accelerator position sensor converts the accelerator opening into an electric signal and outputs it to the engine ECU. There are two types of accelerator position sensor: the hall element type and the contact type. In addition, to provide backup in the event of breakdown, there are two systems and the output voltage is offset.

Hall Element Type

- This sensor uses a hall element to generate voltage from change in the direction of the magnetic field. A magnet is installed on the shaft that rotates linked with the accelerator pedal, and the rotation of this shaft changes the magnetic field of the Hall element. The voltage generated by this change in the magnetic field is amplified by an amplifier and input to the engine ECU.



Contact Type

- The sensor uses a contact-type variable resistor. Since the lever moves linked with the accelerator pedal, the sensor resistance value varies with the accelerator pedal opening. Therefore, the voltage passing the sensor changes, and this voltage is input to the engine ECU as the accelerator opening signal.

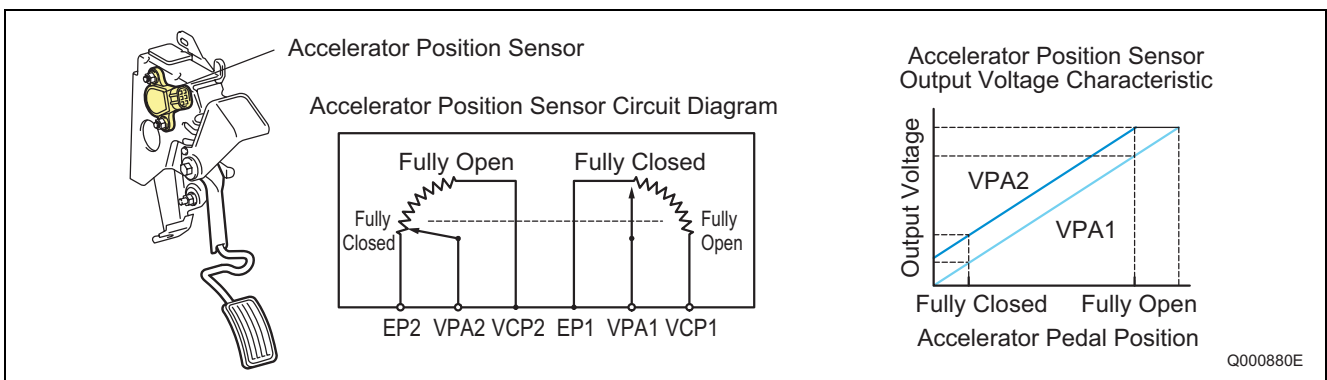

(3) Intake Air Temperature Sensor

- The intake air temperature sensor detects the temperature of the intake air after it has passed the turbocharger. The sensor portion that detects the temperature contains a thermistor. The thermistor, which has an electrical resistance that changes with temperature, is used to detect the intake air temperature.

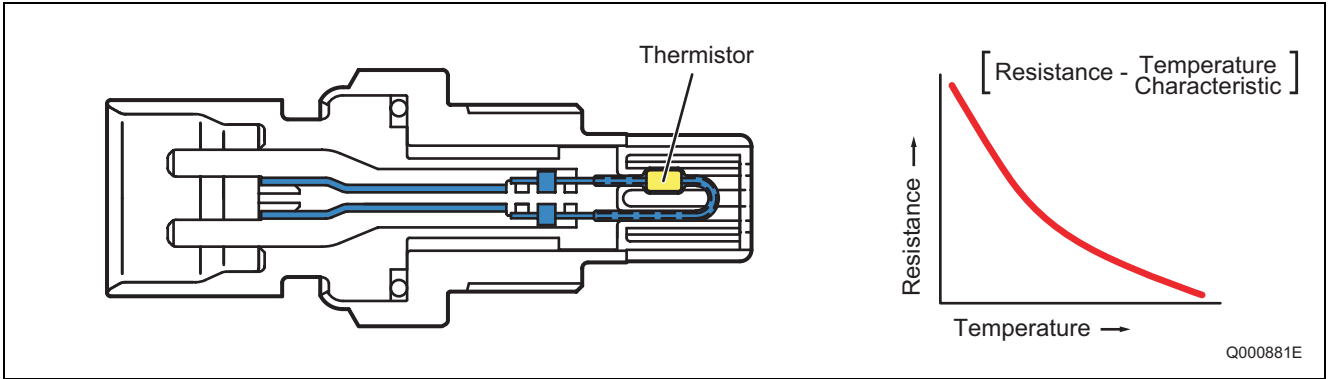

(4) Mass Airflow Meter (with Built-In Intake Air Temperature Sensor)

- The mass air flow meter is installed behind the air cleaner and detects the intake air flow (mass flow). This sensor is a hot-wire type. Since the electrical resistance of the hot wire varies with the temperature, this characteristic is utilized to measure the intake air quantity. The mass airflow meter also has a built-in intake air temperature sensor (thermistor type) and detects the intake air temperature (atmospheric temperature).

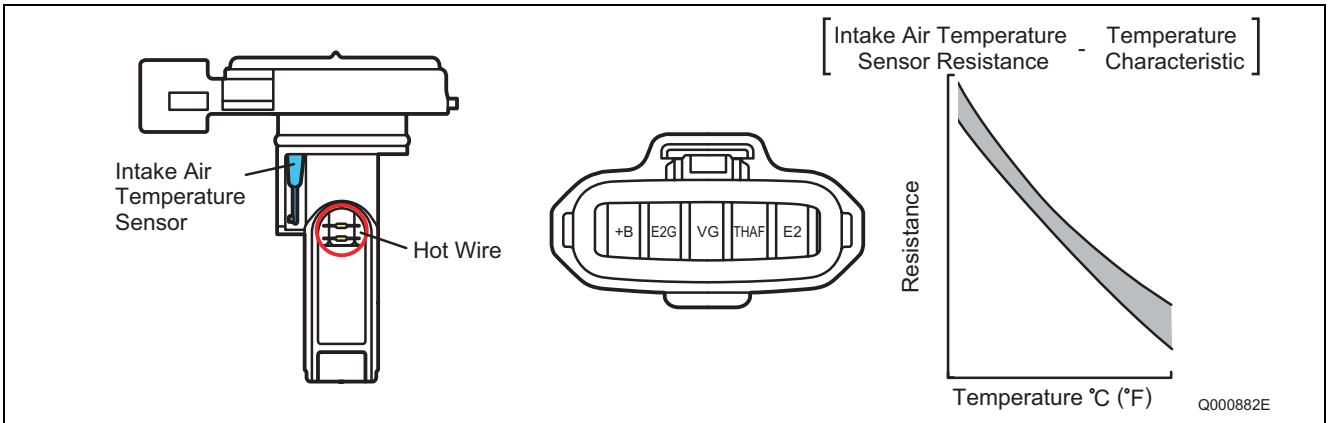

(5) Coolant Temperature Sensor

- The coolant temperature sensor is installed on the cylinder block and detects the coolant temperature. This sensor is a thermistor type.

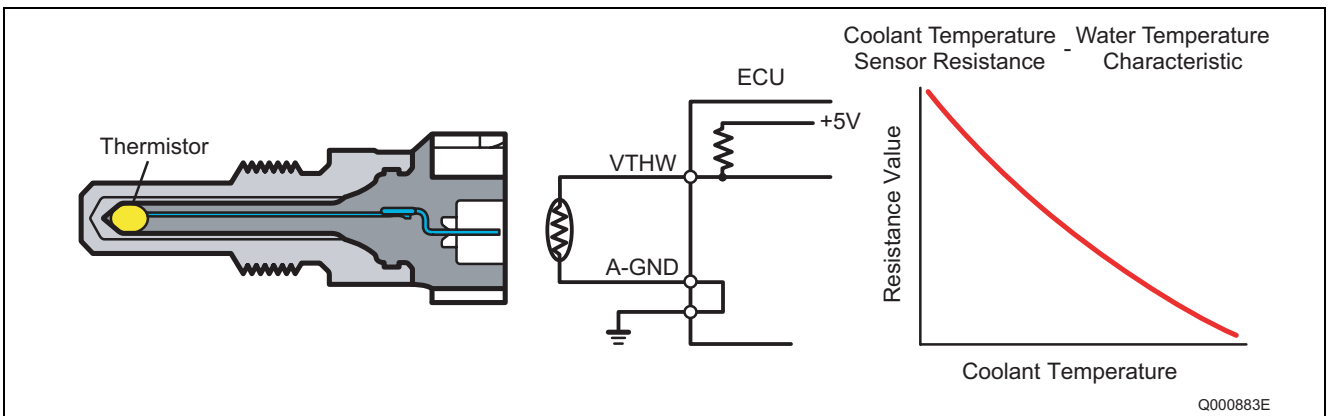

(6) Fuel Temperature Sensor

- This is a thermistor type sensor that detects the fuel temperature. In the HP2, HP3, and HP4 systems, this sensor is installed on the supply pump unit, but in the HP0 system, it is installed on a leak pipe from an injector.

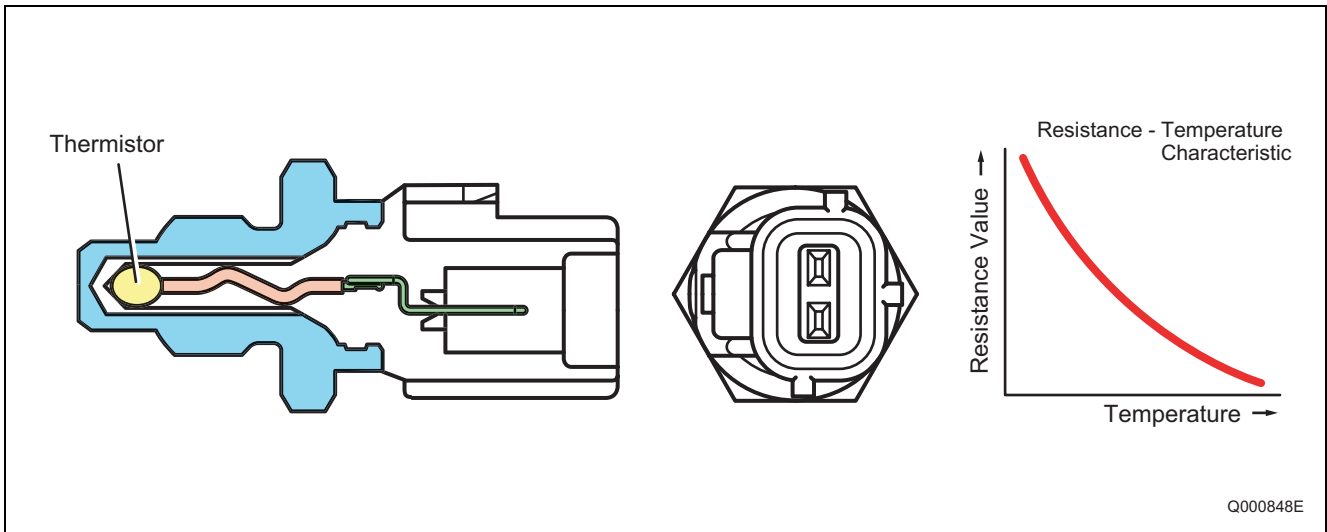

(7) Intake Air Temperature Sensor and Atmospheric Pressure Sensor

- This sensor is a semiconductor type sensor. It measures pressure utilizing the piezoelectric effect that when the pressure on the silicon element in the sensor changes, its electrical resistance changes. In addition, the air pressure on this sensor is switched between the pressure within the intake manifold and the atmospheric pressure, so both the intake air pressure and the atmospheric pressure are detected with one sensor. The switching between intake air pressure and atmospheric pressure is handled by the VSV (vacuum switching valve). When any one of the conditions below is established, the VSV is switched ON for 150 msec. by command of the engine ECU to detect the atmospheric pressure. When none of the conditions below is established, the VSV is switched OFF to detect the intake air pressure.

Atmospheric Pressure Measurement Conditions

- Engine speed = 0 rpm
- Starter ON
- Stable idling state

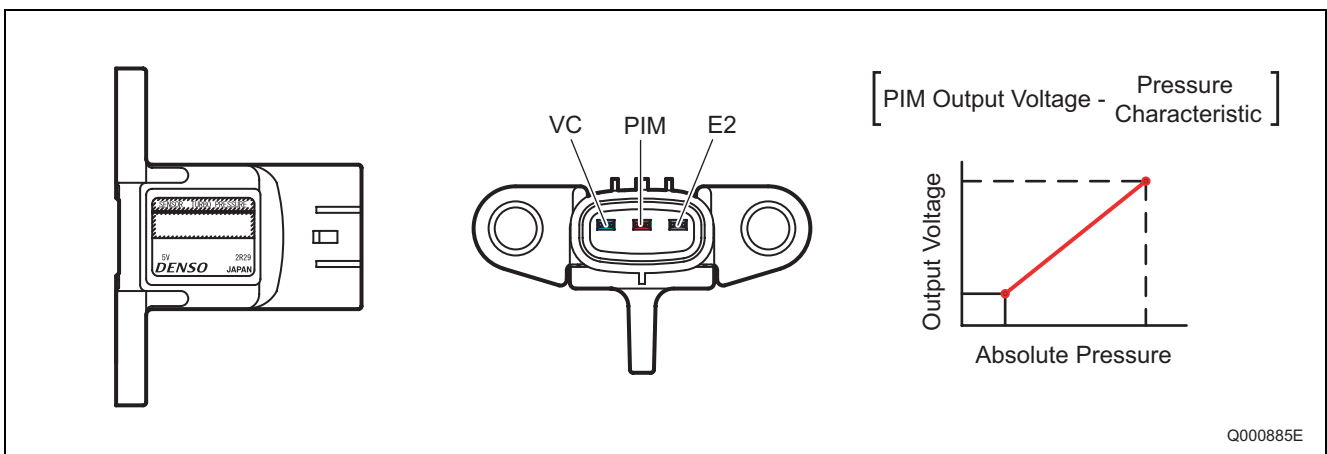

7. CONTROL SYSTEM

7.1 Fuel Injection Control

(1) General Description

- This system effects more appropriate control of the fuel injection quantity and injection timing than the mechanical governor or timer used in the conventional injection pump. The engine ECU performs the necessary calculations based on the signals that are received from the sensors located on the engine and the vehicle. Then, the ECU controls the timing and duration of the current that is applied to the injectors in order to obtain optimal injection timing and injection quantity.

(2) Various Types of Fuel Injection Controls

Control	Functions
Fuel Injection Quantity Control	This control replaces the function of the governor in the conventional injection pump. It achieves optimal injection quantity by effecting control in accordance with the engine speed and accelerator opening signals.
Fuel Injection Timing Control	This control replaces the function of the timer in the conventional injection pump. It achieves optimal injection timing by effecting control in accordance with the engine speed and the injection quantity.
Fuel Injection Rate Control (Pilot Injection Control)	This function controls the ratio of the fuel quantity that is injected from the orifice of the injector within a given unit of time.
Fuel Injection Pressure Control	This control uses the rail pressure sensor to measure the fuel pressure, and it feeds this data to the engine ECU in order to control the pump discharge quantity.

(3) Fuel Injection Quantity Control

General Description

- This control determines the fuel injection quantity by adding coolant temperature, fuel temperature, intake air temperature, and intake air pressure corrections to the basic injection quantity. The engine ECU calculates the basic injection quantity based on the engine operating conditions and driving conditions.

Injection Quantity Calculation Method

- The calculation consists of a comparison of the following two values: 1. The basic injection quantity that is obtained from the governor pattern, which is calculated from the accelerator position and the engine speed. 2. The injection quantity obtained by adding various types of corrections to the maximum injection quantity obtained from the engine speed. The lesser of the two injection quantities is used as the basis for the final injection quantity.

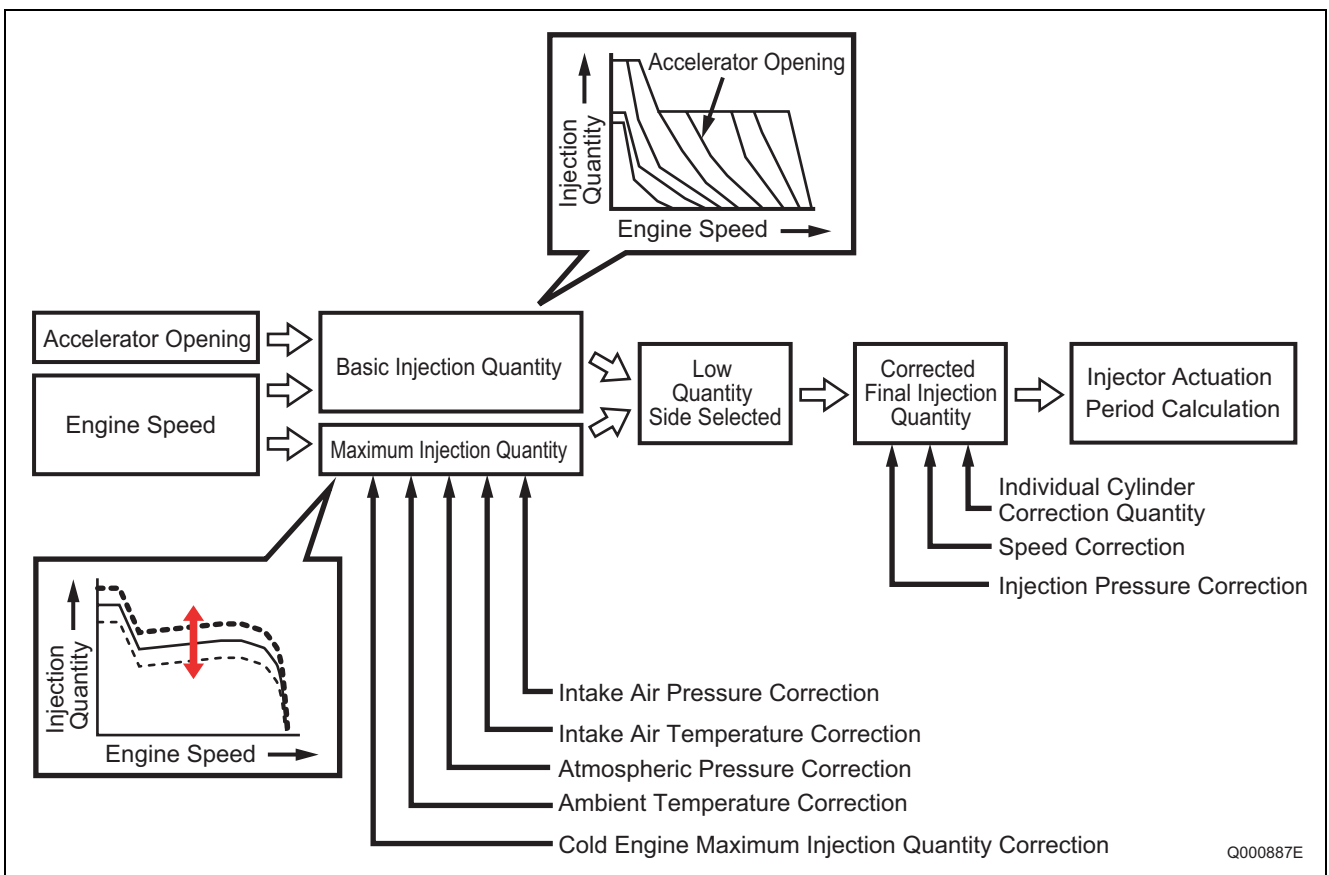

Set Injection Quantities

- Basic Injection Quantity

This quantity is determined by the engine speed and the accelerator opening. With the engine speed constant, if the accelerator opening increases, the injection quantity increases; with the accelerator opening constant, if the engine speed rises, the injection quantity decreases.

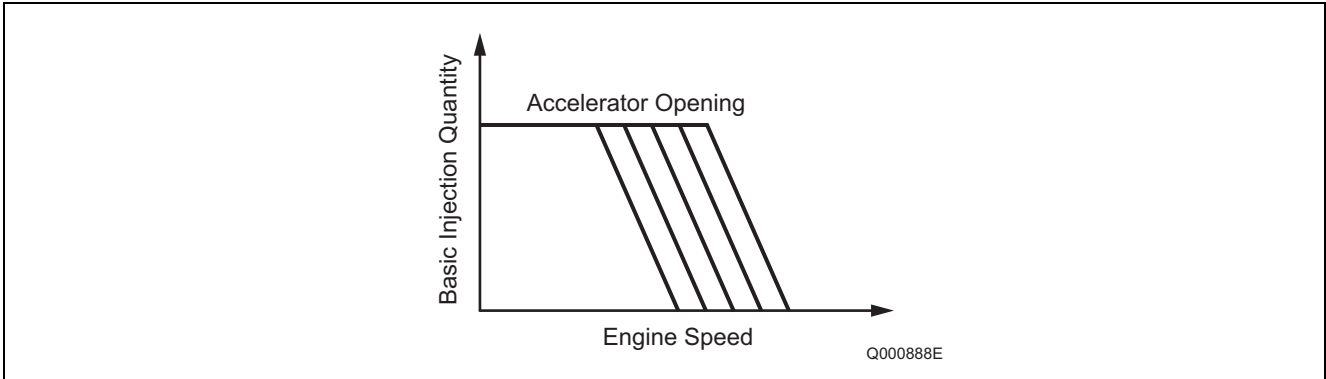

- Starting Injection Quantity

This is determined based on the basic injection quantity for when the engine starts up and the added corrections for the starter S/W ON time, the engine speed, and the coolant temperature. If the coolant temperature is low, the injection quantity is increased. When the engine has completely started up, this mode is cancelled.

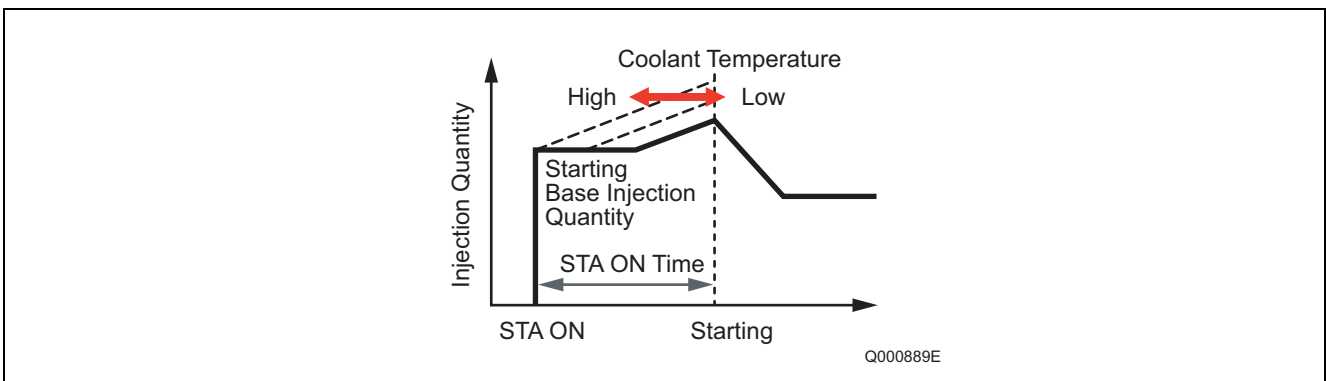

- Injection Quantity for Maximum Speed Setting

Determined by the engine speed. The injection quantity is restricted to prevent an excessive rise in engine speed (overrun).

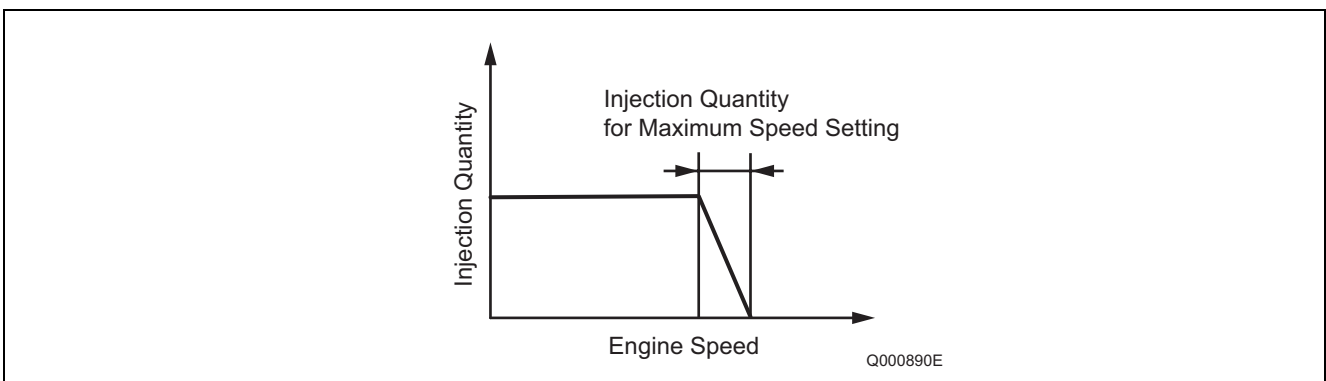

- Maximum Injection Quantity

This is determined based on the basic maximum injection quantity determined by the engine speed, and the added corrections for coolant temperature, fuel temperature, intake air temperature, atmospheric temperature, intake air pressure, atmospheric pressure, and full Q adjustment resistance (only for the 1st generation HP0 system), etc.

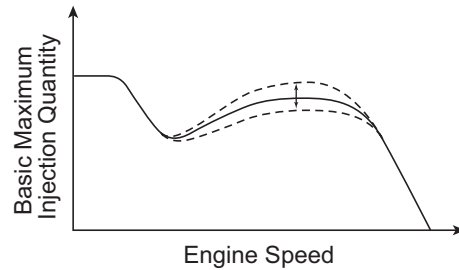

QB0717E

Corrections

- Cold Engine Maximum Injection Quantity Correction

When the coolant temperature is low, whether during start-up or during normal operation, this correction increases the injection quantity.

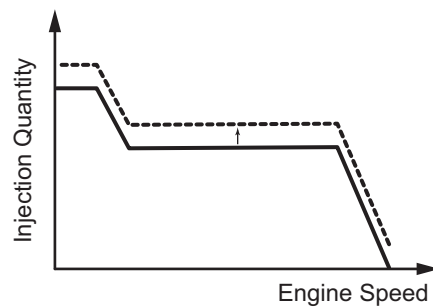

Q000891E

- Intake Air Pressure Correction

When the intake air pressure is low, the maximum injection quantity is restricted in order to reduce the emission of black smoke.

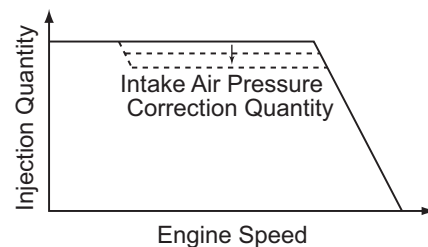

Q000892E

- Atmospheric Pressure Correction

The maximum injection quantity is increased and decreased according to the atmospheric pressure. When the atmospheric pressure is high, the maximum injection quantity is increased.

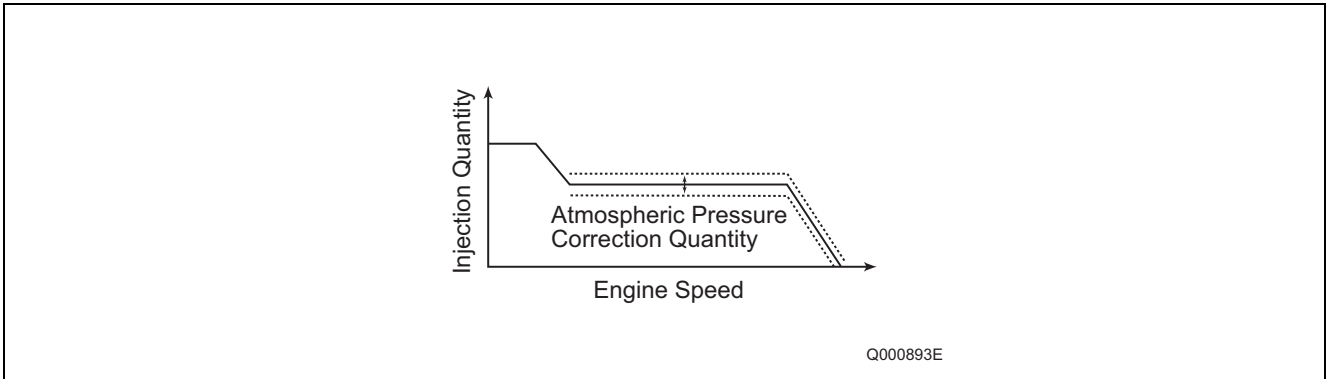

- Injection Quantity Delay Correction for Acceleration

During acceleration, if there is a large change in the accelerator pedal opening, the injection quantity increase is delayed in order to prevent black smoke emissions.

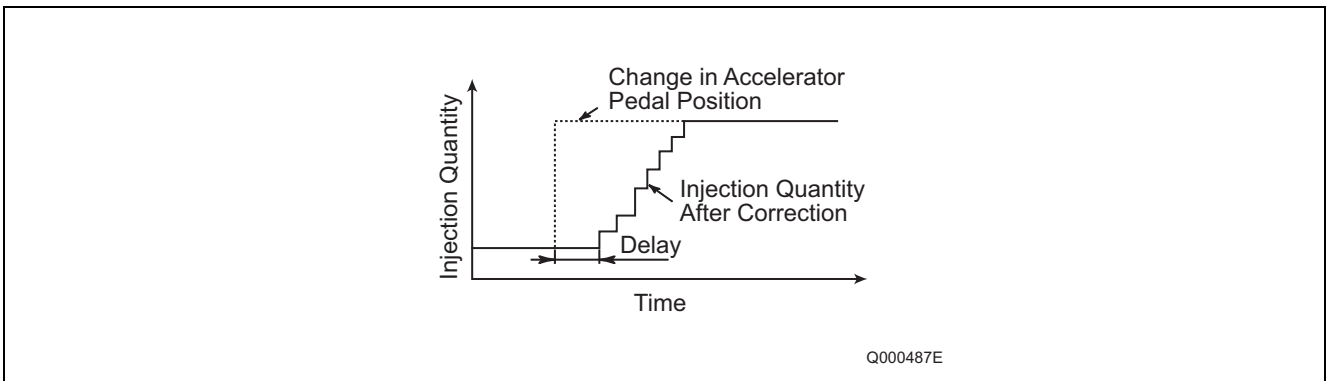

- Full Q Adjustment Resistance (Only for 1st Generation HP0 Systems)

The full Q resistance is for correcting the injection quantity for a full load. The maximum injection quantity is increased or decreased by the car manufacturer to match to standards. There are 15 types of full Q adjustment resistance. The appropriate one is selected and used.

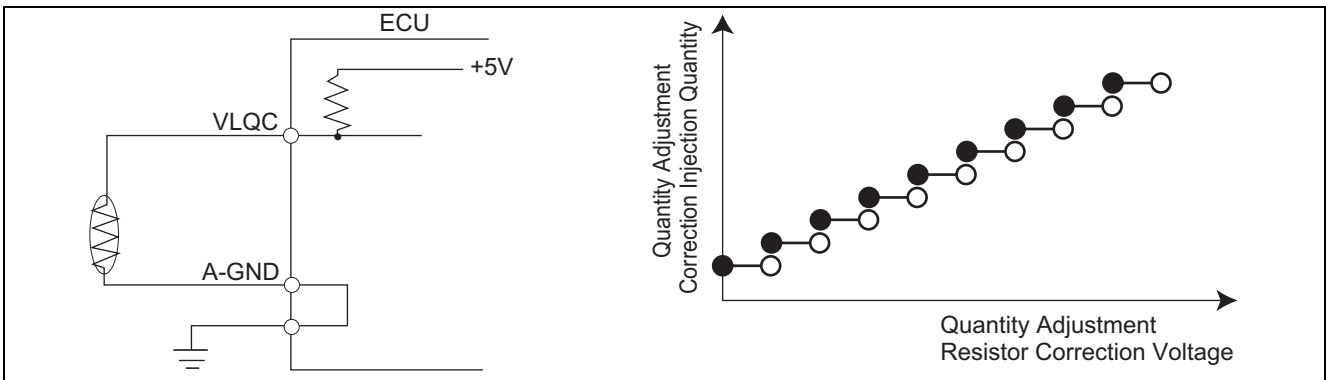

(4) Fuel Injection Rate Control

- Although the injection rate increases with the adoption of high-pressure fuel injection, the ignition lag, which is the delay from the start of injection to the beginning of combustion, cannot be shortened to less than a certain period of time. Therefore, the quantity of fuel injected until ignition takes place increases (the initial injection rate is too high), resulting in explosive combustion simultaneous with ignition, and an increase in NO_x and sound. To counteract this situation, pilot injection is provided to keep the initial injection at the minimum requirement rate, to dampen the primary explosive combustion, and to reduce NO_x and noise.

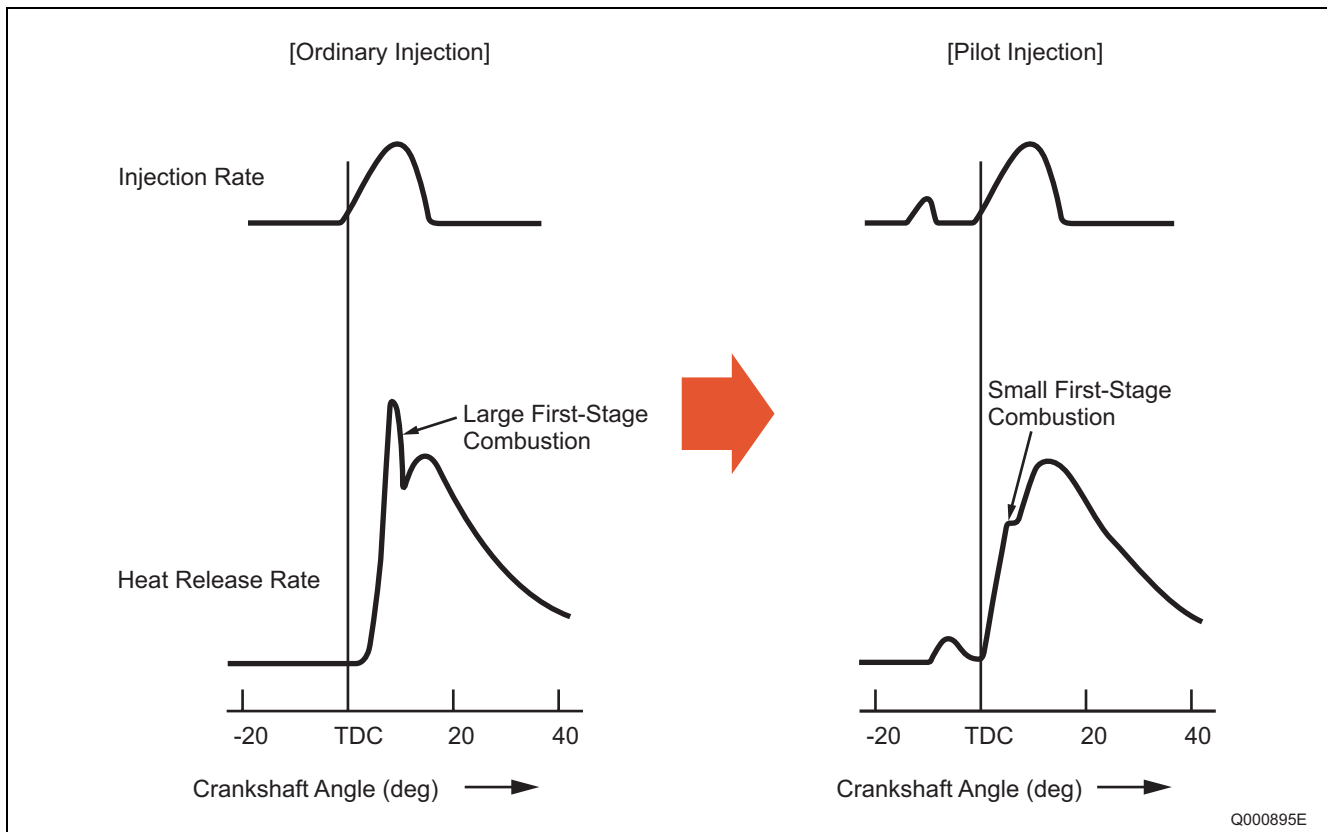

(5) Fuel Injection Timing Control

- The fuel injection timing is controlled by the timing of the current applied to the injectors. After the main injection period is decided, the pilot injection and other injection timing is determined.

Main Injection Timing

- The basic injection timing is calculated from the engine speed (engine speed pulse) and the final injection quantity, to which various types of corrections are added in order to determine the optimal main injection timing.

Pilot Injection Timing (Pilot Interval)

- Pilot injection timing is controlled by adding a pilot interval value to the main injection. The pilot interval is calculated based on the final injection quantity, engine speed, coolant temperature, atmospheric temperature, and atmospheric pressure (map correction). The pilot interval at the time the engine is started is calculated from the coolant temperature and engine speed.

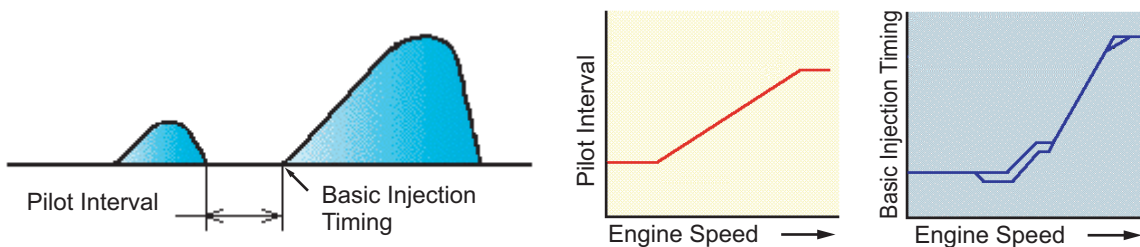

1. Outline of Injection Timing Control Timing

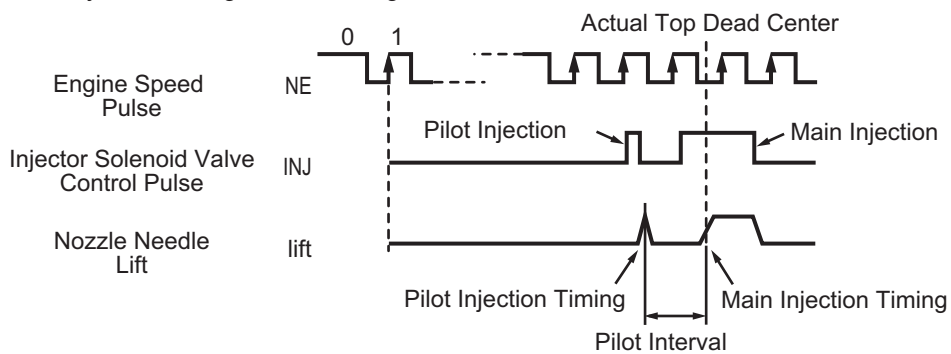

2. Injection Timing Calculation Method

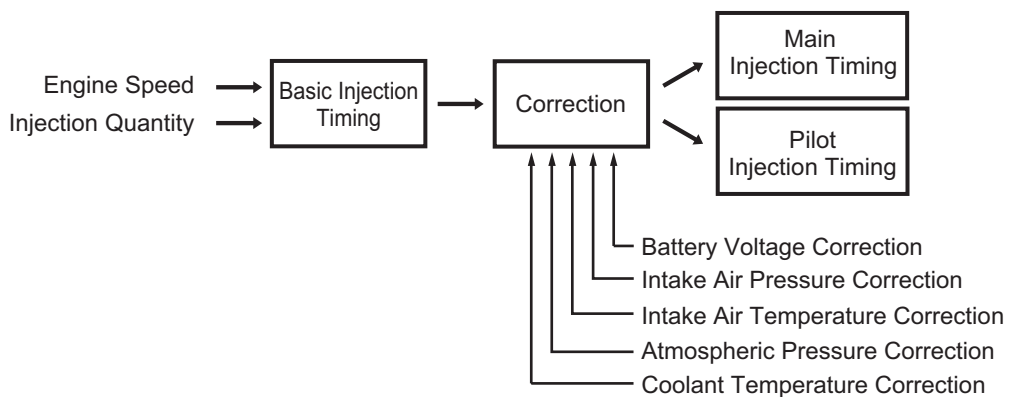

Split Injection

- The purpose of split injection is to improve the startability of a cold engine. Before the conventional main injection takes place, this function injects two or more extremely small injections of fuel.

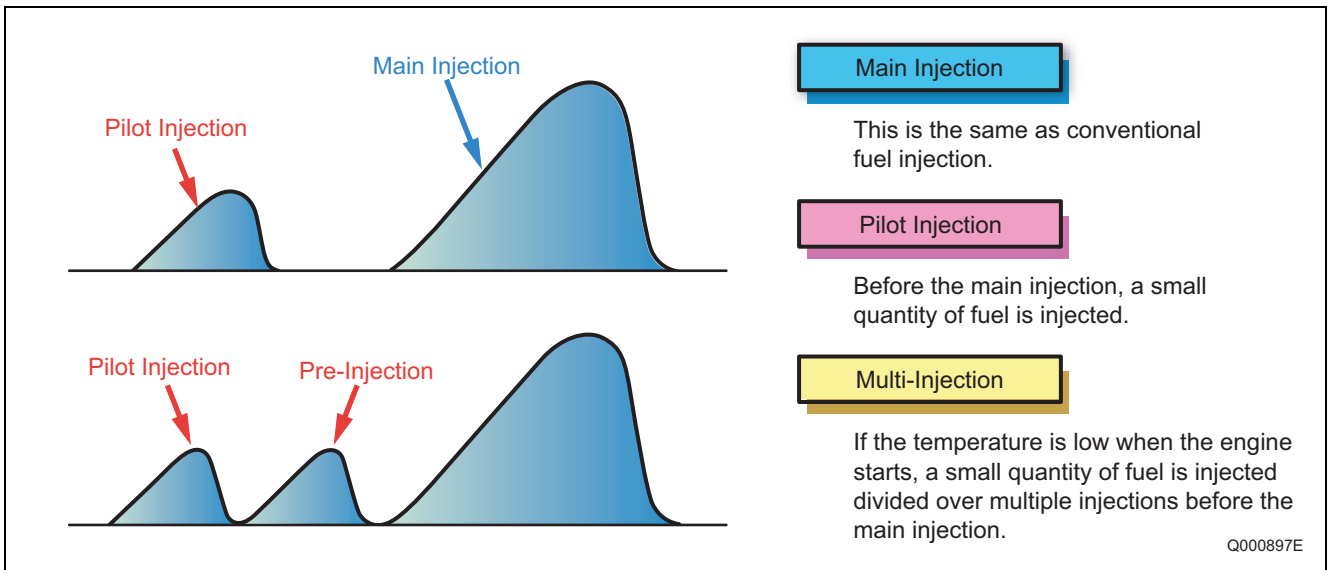

Multi-Injection Control (Only for Some Models)

- Multi-injection control is when small injections (up to four times) are carried out before and after the main injection in accordance with the state of the main injection and engine operation. This interval (the time A-D in the diagram below) is based on the final injection quantity, engine speed, coolant temperature, and atmospheric pressure (map correction). The interval during start-up is based on the coolant temperature and engine speed.

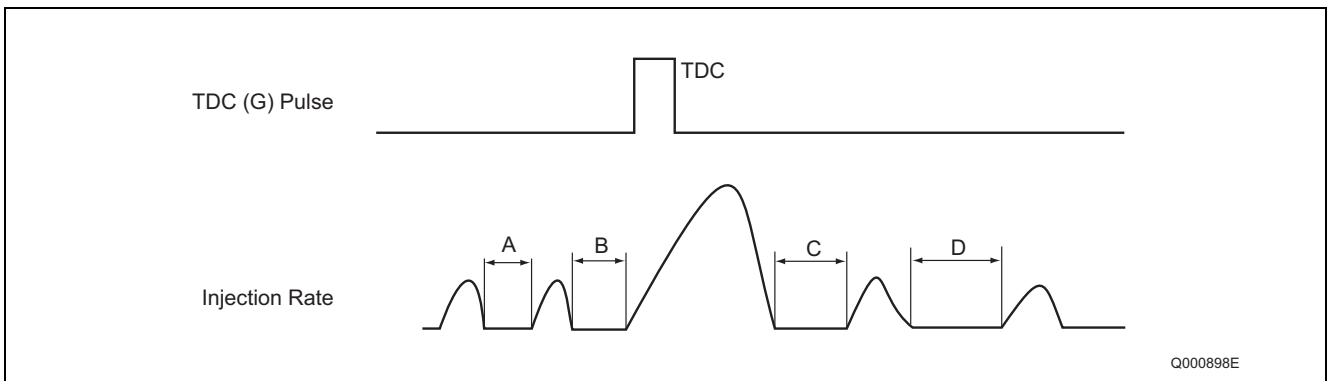

(6) Fuel Injection Pressure Control

- The engine ECU calculates the fuel injection pressure, which is determined by the final injection quantity and the engine speed. The calculation is based on the coolant temperature and engine speed during start-up.

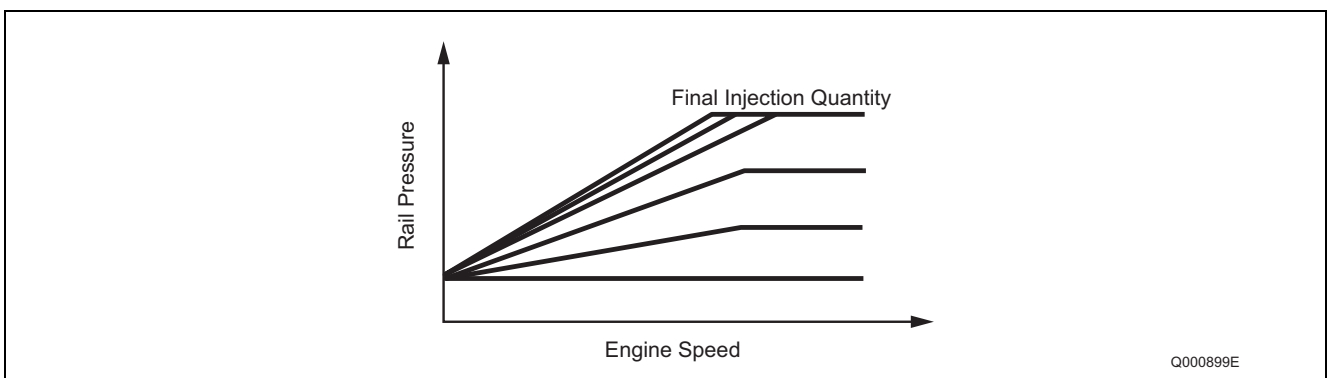

(7) Other Injection Quantity Control

Idle Speed Control (ISC) System

- The idle speed control system controls the idle speed by regulating the injection quantity in order to match the actual speed to the target speed calculated by the computer. The ISC can be automatic ISC or manual ISC.

Automatic ISC

- With automatic ISC, the engine ECU sets the target speed. The target engine speed varies with the type of transmission (automatic or manual), whether the air conditioner is ON or OFF, the shift position, and the coolant temperature.

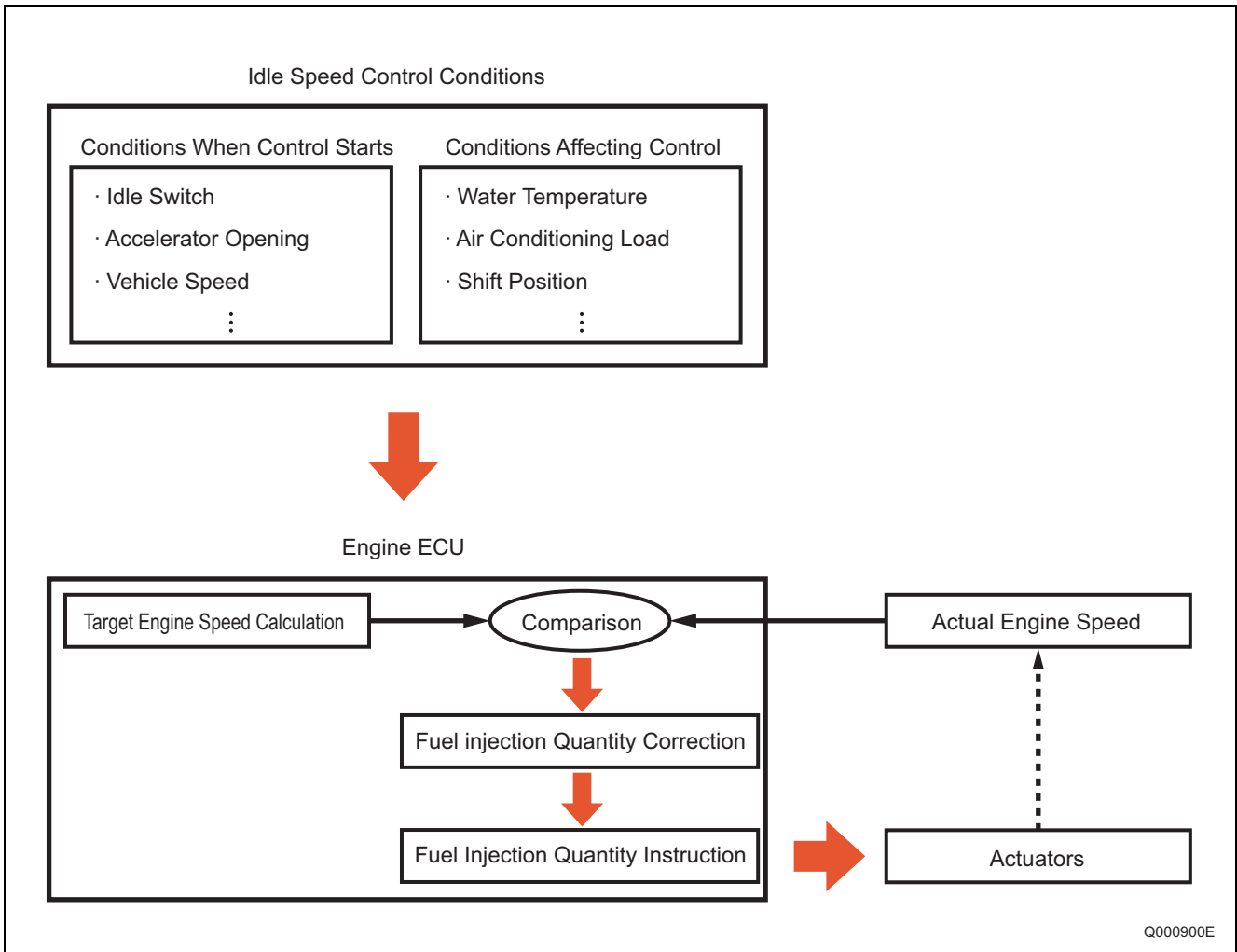

Q000900E

Manual ISC

- The idle engine speed is controlled by the setting on the idle setting button at the driver's seat.

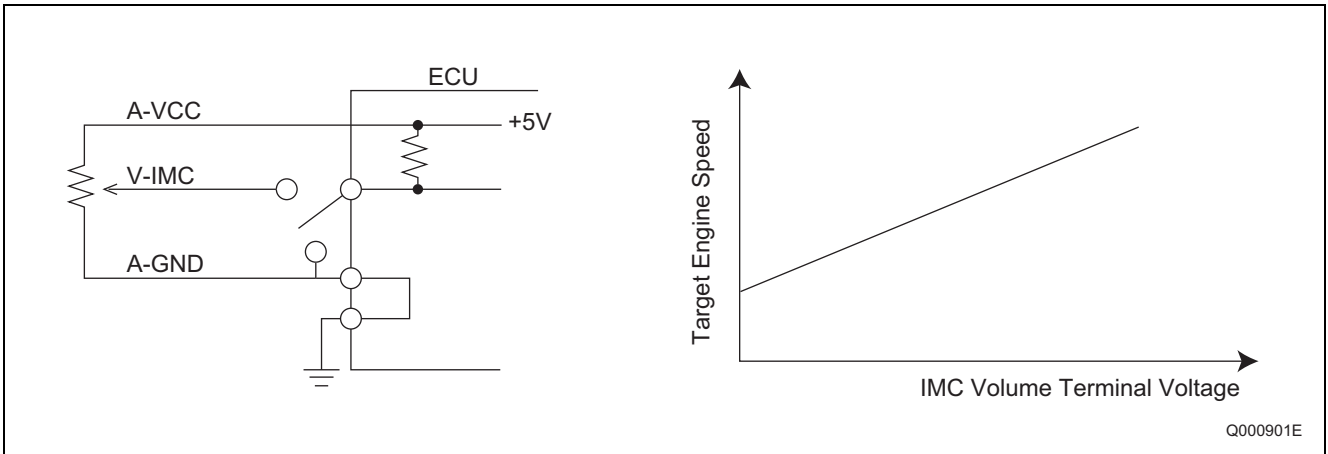

Idle Vibration Reduction Control

- This control reduces engine vibration during idle. To achieve smooth engine operation, it compares the angle speeds (times) of the cylinders and regulates injection quantity for each individual cylinder in the event of a large difference.

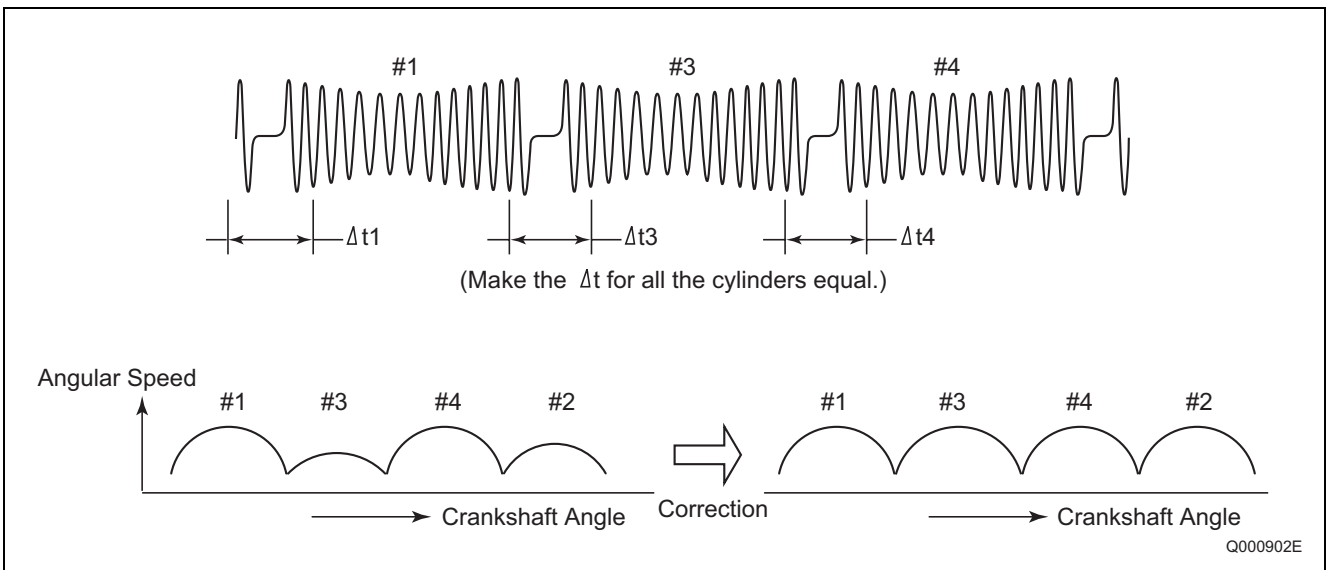

7.2 E-EGR System (Electric-Exhaust Gas Recirculation)

(1) General Description

- The E-EGR system is an electronically controlled EGR system. The EGR system recirculates a portion of the exhaust gases into the intake manifold in order to lower the combustion chamber temperature and reduce NOx emissions. However, operation of the EGR system may reduce engine power output and affect drivability. For this reason, in the E-EGR system, the engine ECU controls the EGR to achieve an optimal EGR amount.

Operation Conditions Example

- This operates in the operation region fulfilling the starting conditions below (one example).

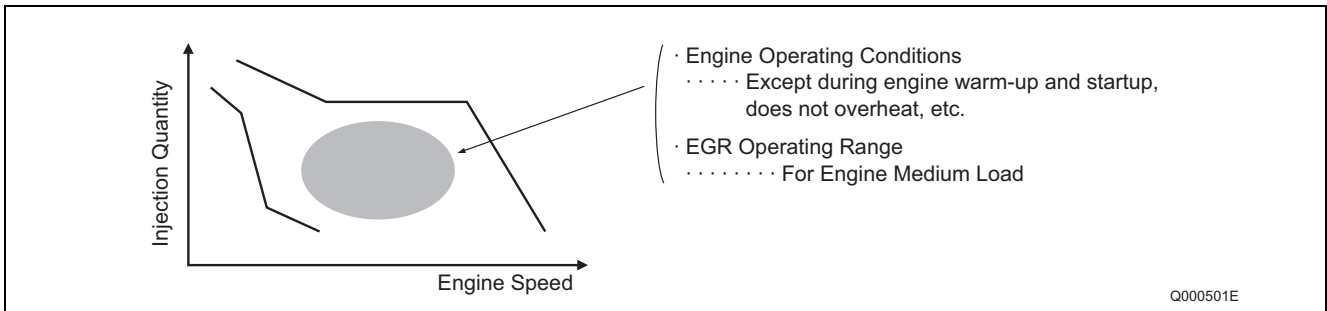

(2) Operation

- After the vacuum pump generates a vacuum, the E-VRV (electric-vacuum regulation valve) regulates the vacuum and directs it to the diaphragm chamber of the EGR valve. In response to this vacuum, the diaphragm pushes the spring downward, which determines the opening of the EGR valve and controls the EGR volume.
- The EGR cooler, which is provided in the EGR passage between the cylinder head and the intake passage, cools the EGR in order to increase the EGR volume.
- The EGR cutoff VSV, which opens the diaphragm chamber to the atmosphere when the EGR valve is closed, helps to improve response.

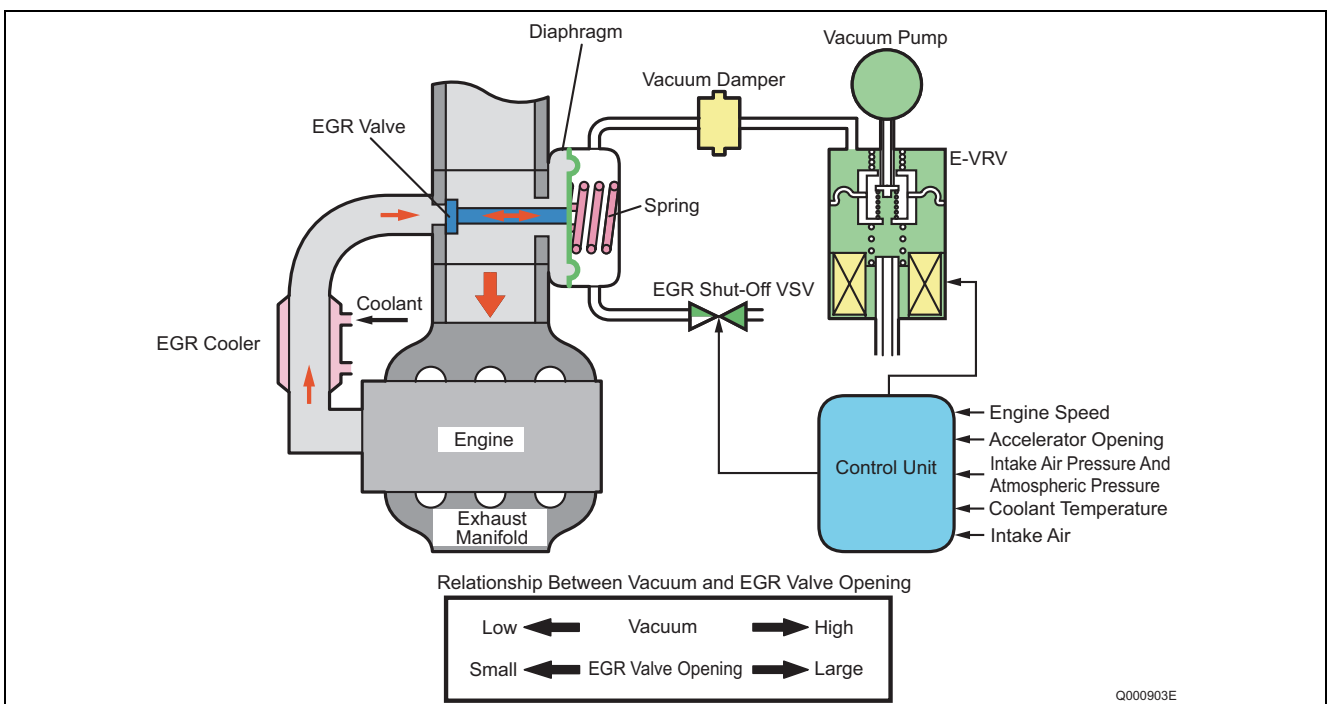

To Increase the EGR Quantity

- The E-VRV duty ratio is controlled*1. In the stable condition shown in the bottom center diagram, an increase in the current that is applied to the coil causes the attraction force FM in the coil to increase. When this force becomes greater than the vacuum force FV that acts on the diaphragm, the moving core moves downward. Along with this movement, the port from the vacuum pump to the upper chamber of the diaphragm opens. Consequently, the output vacuum increases, which causes the EGR valve to open and the EGR volume to increase. Meanwhile, because "increased output vacuum equals increased FV", the moving core moves upward with the increase in FV. When FM and FV are equal, the port closes and the forces stabilize. Because the vacuum circuit of the EGR is a closed loop, it maintains the vacuum in a stabilized state, provided there are no changes in the amperage.

< NOTE >

*1 : The engine ECU outputs sawtooth wave signals with a constant frequency. The value of the current is the effective (average) value of these signals. For details, see the explanation of the HP3 supply pump and SCV.

To Decrease the EGR Volume

- A decrease in the current that is applied to the coil causes FV to become greater than FM. As a result, the diaphragm moves upward. The moving core also moves upward in conjunction with the movement of the diaphragm, causing the valve that seals the upper and lower diaphragm chambers to open. Consequently, the atmospheric pressure in the lower chamber enters the upper chamber, thus reducing the output vacuum. This causes the EGR valve to close and the EGR volume to decrease. Because "decreased output vacuum equals decreased FV", the moving core moves downward with the decrease in FV. When FM and FV are equal, the port closes and the forces stabilize.

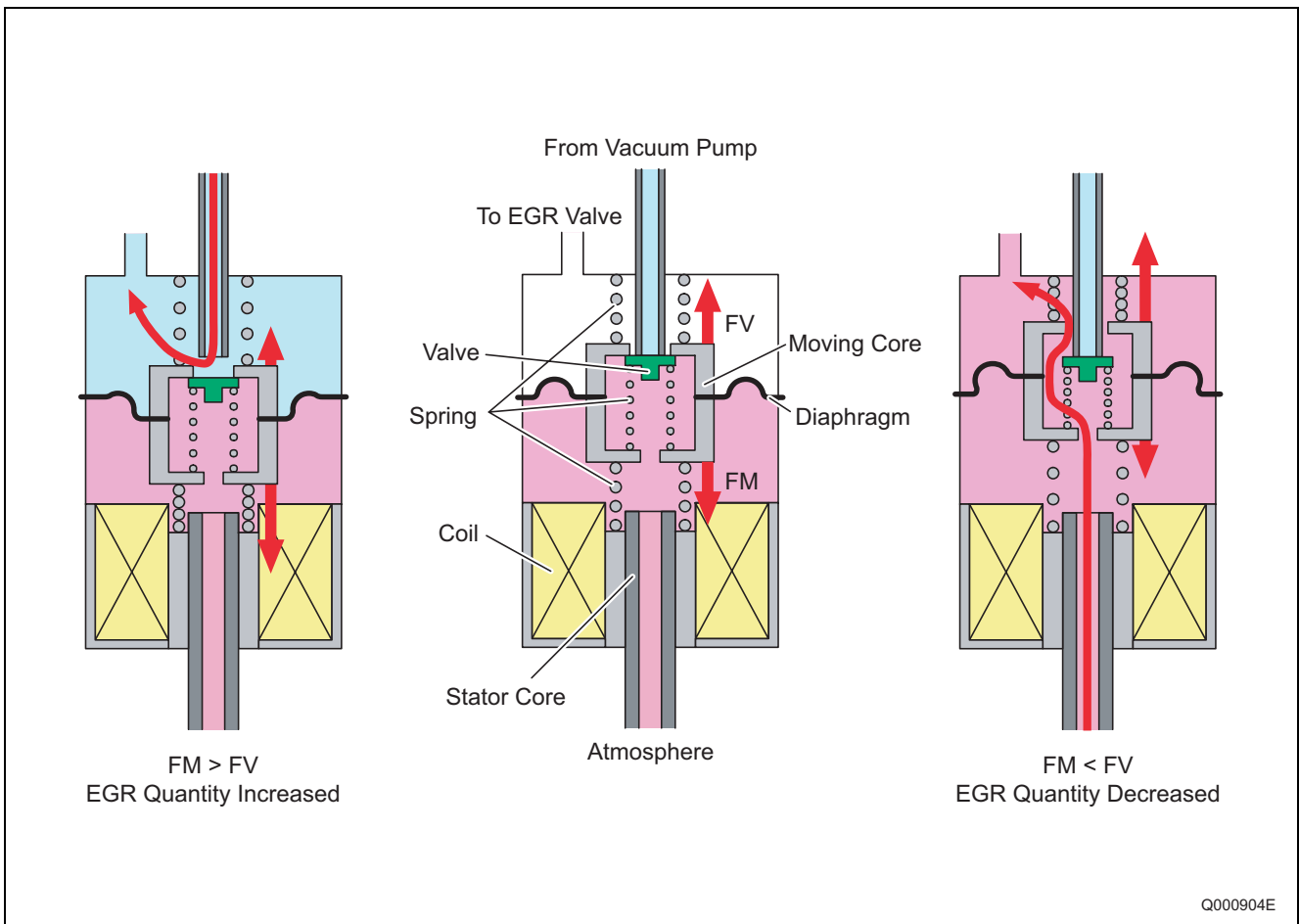

7.3 Electronically Controlled Throttle (Not Made By DENSO)

(1) General Description

- The electronically controlled throttle is located upstream of the EGR valve in the intake manifold. It controls the throttle valve at an optimal angle to regulate the EGR gas and reduce noise and harmful exhaust gases.

(2) Operation

- Signals from the engine ECU actuate the stepping motor, which regulates the throttle valve opening.

EGR Control

- To further increase the EGR volume when the EGR valve is fully open, the vacuum in the intake manifold can be increased by reducing the throttle valve opening, which restricts the flow of the intake air.

Noise and Exhaust Gas Reduction

- When the engine is being started, the throttle valve opens fully to reduce the emissions of white and black smoke.
- When the engine is being stopped, the throttle valve closes fully to reduce vibration and noise.
- During normal driving, the throttle valve opening is controlled in accordance with the engine conditions, coolant temperature, and atmospheric pressure.

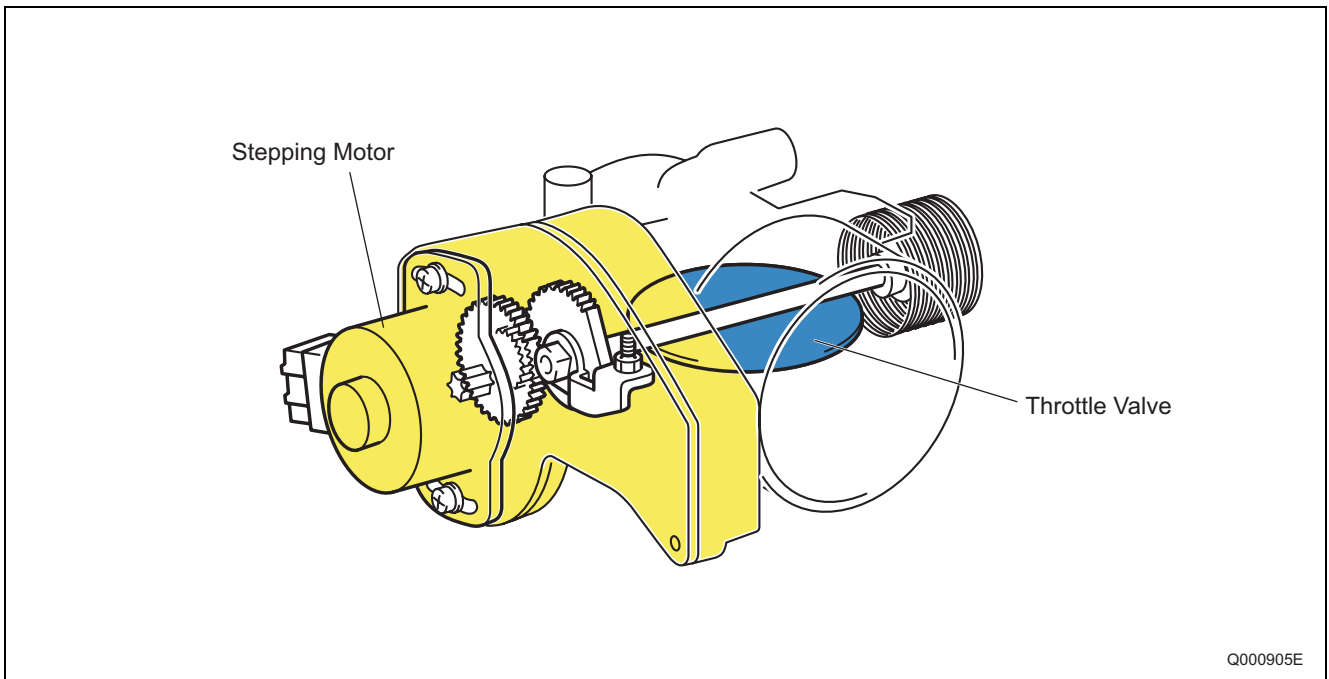

7.4 Exhaust Gas Control System

(1) General Description

- The exhaust gas control system is provided to improve warm-up and heater performance. This system actuates the exhaust gas control valve VSV, which is attached to the exhaust manifold. It increases the exhaust pressure to increase the exhaust temperature and engine load, in order to improve warm-up and heater performance.

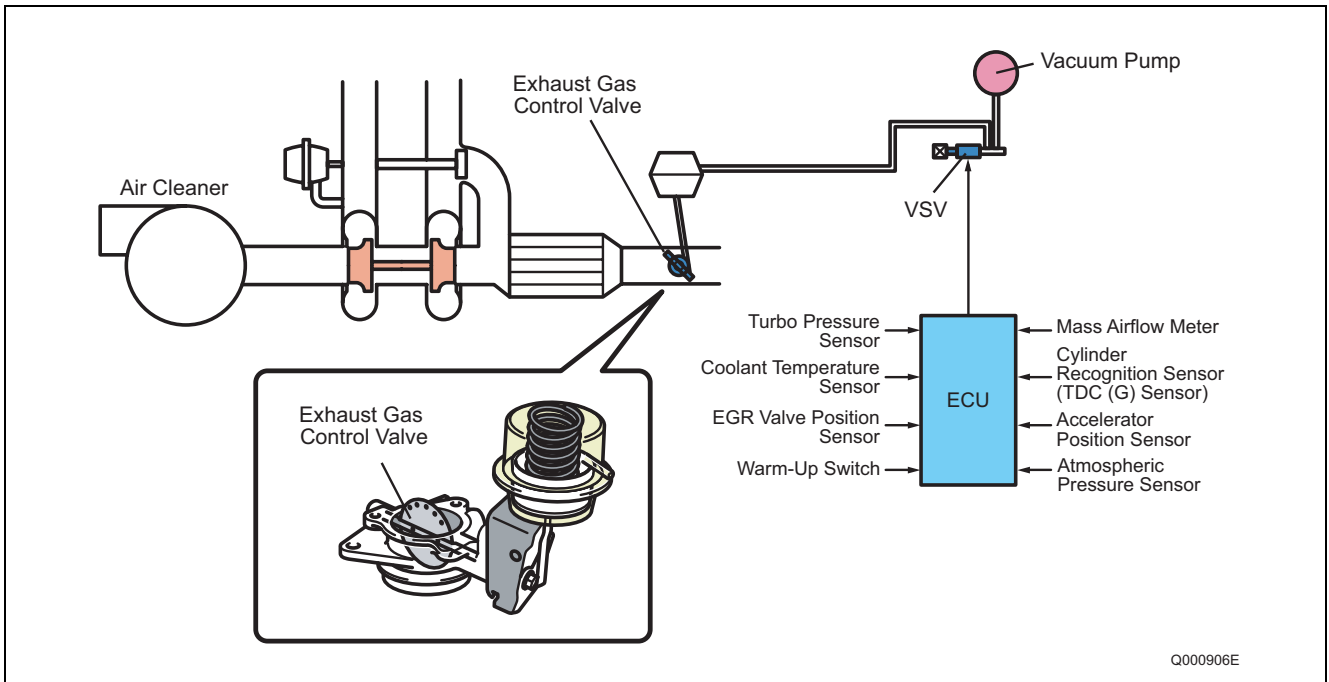

(2) Operation

- The exhaust gas control system operates when the warm-up switch is ON, and all the conditions listed below have been met.

Operation Conditions

- The EGR is operating.
- The coolant temperature is below 70°C.
- The ambient temperature is below 5°C.
- A minimum of 10 seconds have elapsed after starting the engine.
- The engine speed and fuel injection quantity are in the state shown in the graph below.

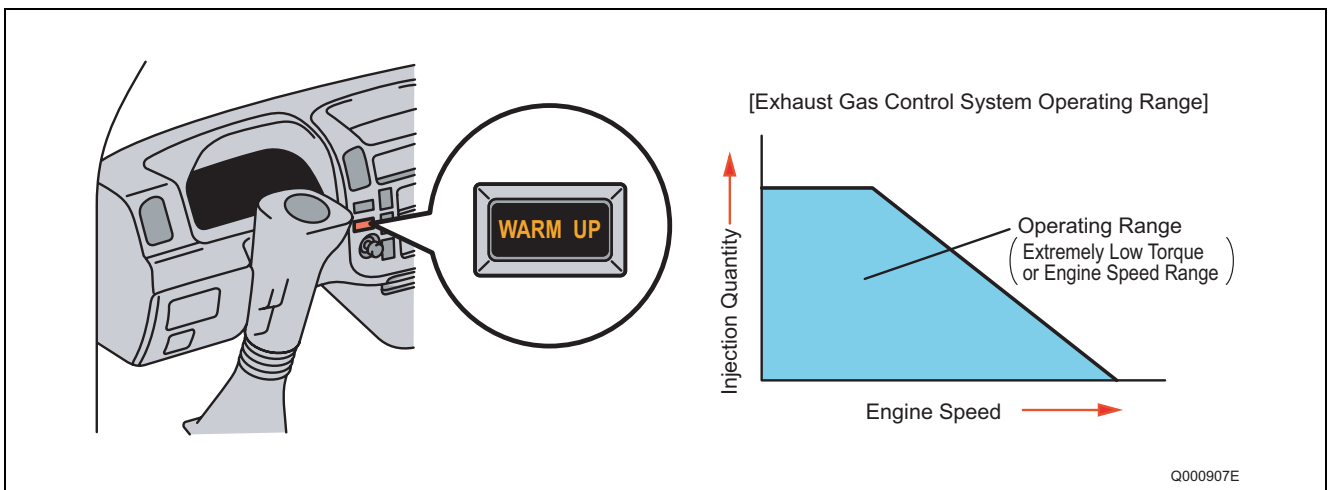

7.5 DPF System (Diesel Particulate Filter)

(1) General Description

- This system reduces emissions of PM (particulate matter). In order to collect PM, a DPF cleaner with built-in catalytic filter is mounted on the center pipe. The collected PM is handled with combustion processing during operation.

(2) System Configuration

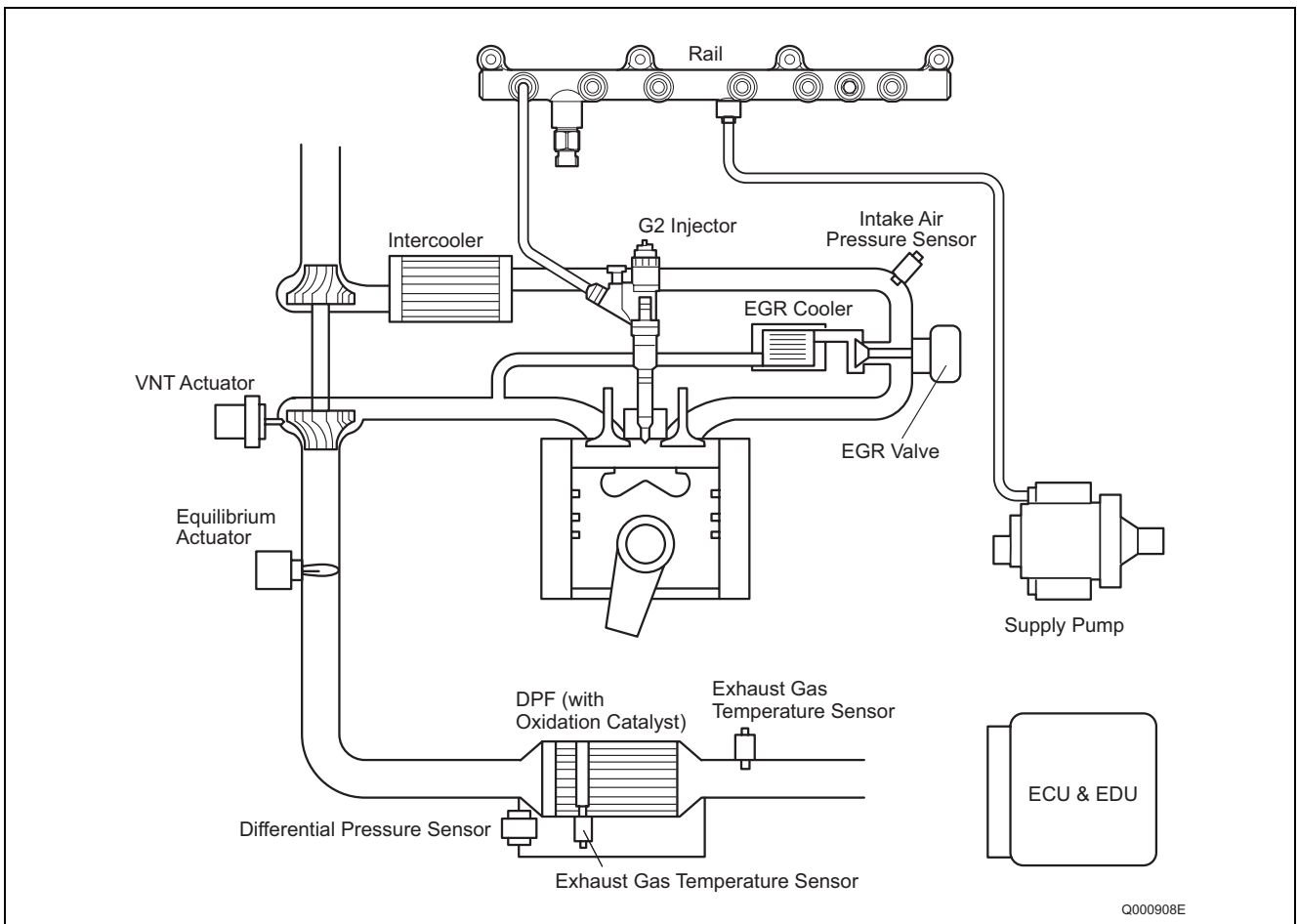

(3) Various Sensors

Exhaust Gas Temperature Sensor

- The exhaust gas temperature sensor is installed to the front and rear of the DPF to detect the temperature in these positions. The engine ECU controls the exhaust temperature for PM combustion based on the signals from this sensor. The sensor element is a thermistor.

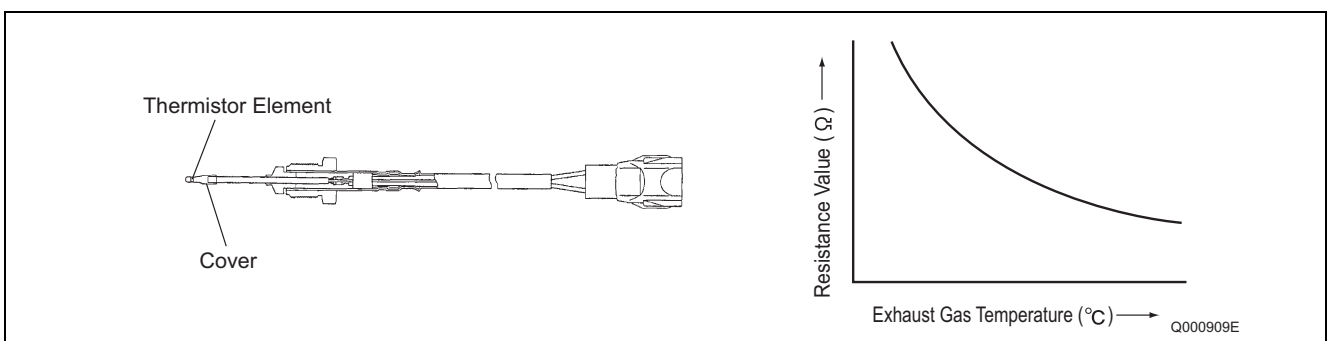

Differential Pressure Sensor

- The differential pressure sensor detects the difference in pressure at the front and rear of the DPF, and outputs a signal to the engine ECU. The sensor portion is a semiconductor type pressure sensor that utilizes the piezoelectric effect through a silicon element, and amplifies and outputs the voltage with its IC circuit. When PM is collected and accumulated in the DPF, the filter clogs and the difference in pressure at the front and rear of the DPF increases. Therefore, based on the signals from this sensor, the engine ECU judges whether or not to subject PM to combustion processing.

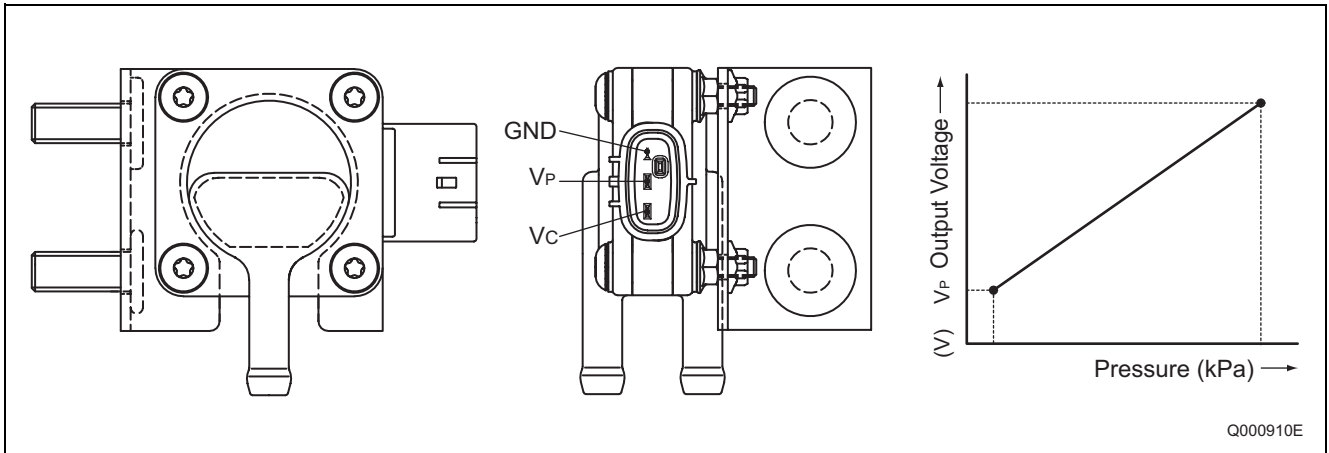

(4) Operation

- By optimizing the injection pattern and controlling the exhaust gas temperature based on the exhaust gas temperature and the difference in pressure at the front and rear of the DPF, PM is collected, oxidized, and self-combusted. When the exhaust temperature is low, adding after-injection after the main injection raises the exhaust gas temperature to approximately 250°C and promotes oxidation of the PM. When the PM is collected and accumulated, the post-injection is added and HC is added to the catalyst to raise the catalyst temperature to 600°C, which is the self-combustion temperature for PM. This combusts the accumulated PM in a short time. The engine ECU controls the A, B, and C times and the injection times.

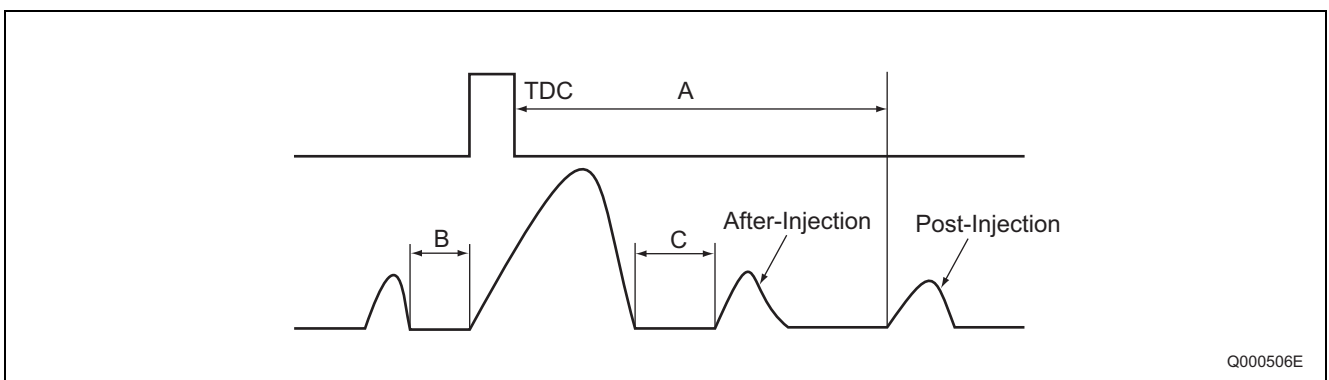

7.6 DPNR SYSTEM (DIESEL PARTICULATE NO_x REDUCTION)

(1) General Description

- This system reduces the emissions of PM (particulate matter) and NO_x. The DPNR catalyst mounted in the center pipe collects and regenerates PM and reduces NO_x all at the same time. The collected PM is handled with combustion processing during operation.

(2) System Configuration

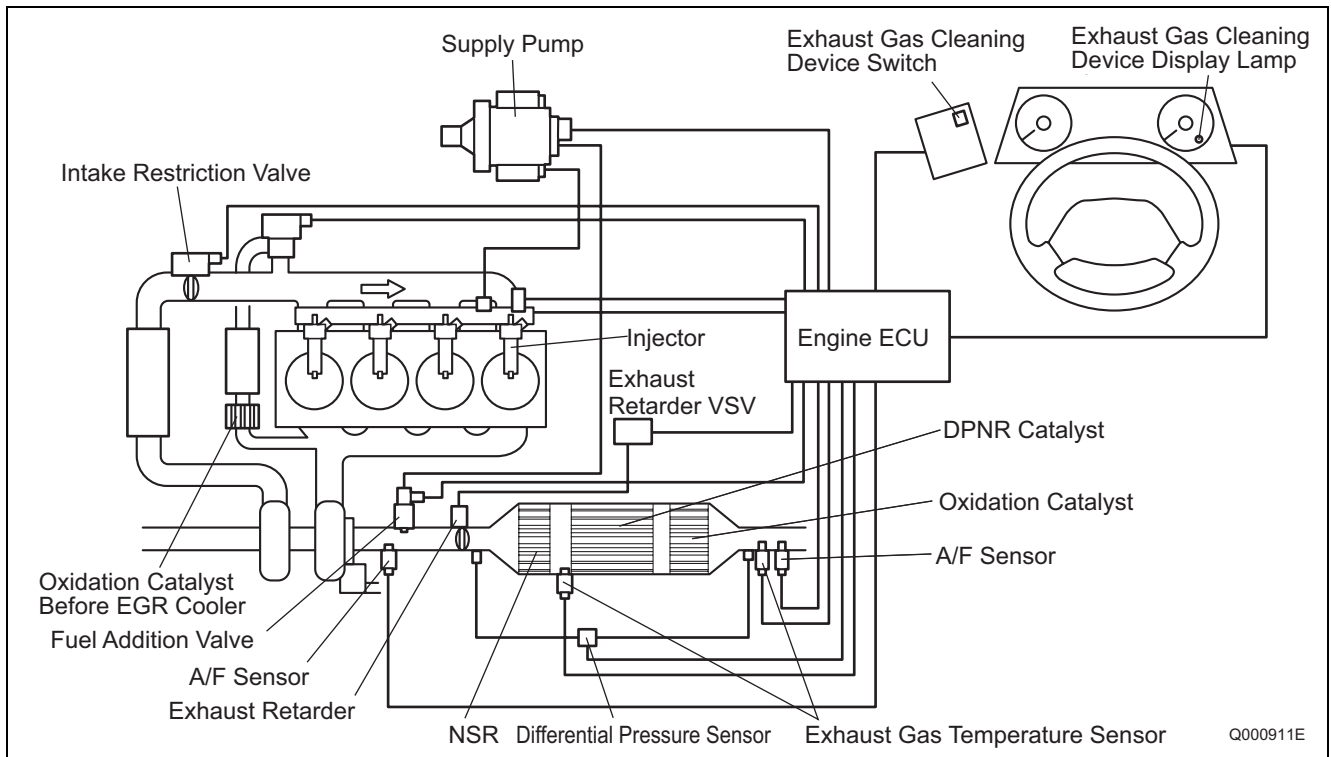

8. DIAGNOSIS

8.1 Outline Of The Diagnostic Function

- The diagnostic function enables a system to self-diagnose its own malfunctions. If abnormal conditions occur in the sensors or actuators used in the control systems, the respective systems convert the malfunction signals into codes and transmit them to the engine ECU. The engine ECU records the transmitted malfunction code into memory. Recorded codes are output at the diagnostics connector on the vehicle. To inform the driver of the malfunction, the engine ECU causes the MIL (Malfunction Indicator Light) in the meter to illuminate. Accurate troubleshooting can be performed by way of the DTCs (Diagnostic Trouble Codes) that are output at the diagnostic connector. For details on actual diagnosis codes, see the vehicle manual. It is necessary to put the vehicle into the state below before starting inspection.

(1) Pre-Inspection Preparation

- Position the shift lever in "N" or "P".
- Turn OFF the air conditioner.
- Verify that the throttle valve is fully closed.

8.2 Diagnosis Inspection Using DST-1

- The DST-1 can be used in both normal and check modes. Compared to the normal mode, the check mode has a higher sensitivity to detect malfunctions.
- The check mode inspection is performed when normal codes are output in the normal mode, despite the fact that there may be malfunctions in the sensor signal systems.

(1) Reading DTCs

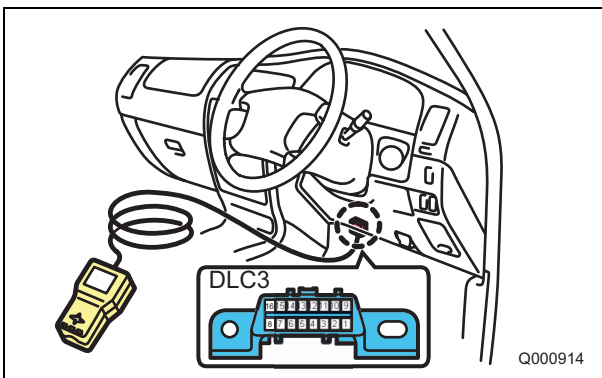

- 1) DST-1 Connection: Connect the DST-1 to the DLC3 terminal.

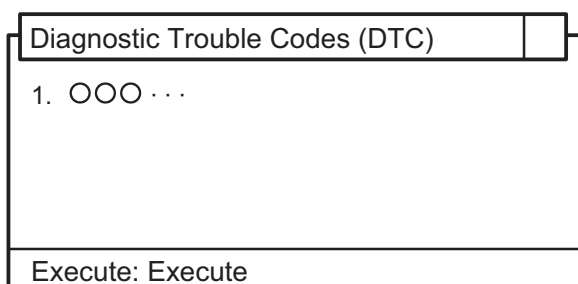

- 2) Reading DTCs: Operate in accordance with the instructions shown on the screen to display the "DTC check" screen. Select either the normal or check mode and read the DTC.

< NOTE >

If no DTC appears on the screen, there may be a failure in the engine ECU.

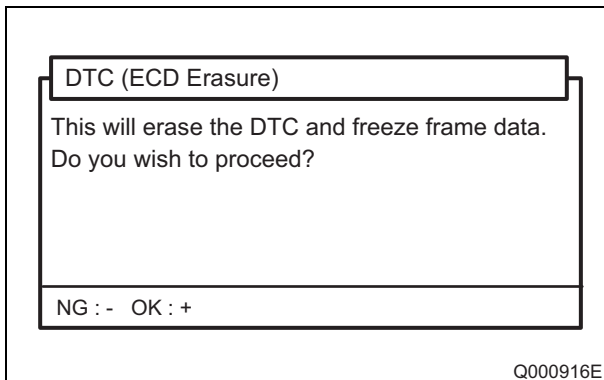

3) Checking the Freeze Frame Data: If the symptom that outputs a DTC cannot be duplicated, check the freeze frame data.

4) Erasing DTCs from memory: Operate in accordance with the instructions shown on the screen to display the "DTC check" screen. Select "Erase DTCs" to erase the DTCs.

< NOTE >

If it is not possible to erase the DTC, turn the ignition switch OFF, and repeat the process.

5) Wiring Harness and Connector Open Circuit Check

< NOTE >

If the DTC output during a diagnostic inspection (in the check mode) has identified the system with a malfunction, use the method indicated below to narrow down the area of the malfunction.

- Erasing DTCs from memory: After reading the DTCs in check mode, erase the DTCs from memory.
- Starting the Engine: Select the check mode and start the engine.
- Malfunctioning system check 1: While the engine is running at idle, shake the wiring harness and connectors of the system that output the malfunction during the diagnosis (check mode) inspection.
- Malfunctioning system check 2: If the MIL (Malfunction Indicator Light) illuminates when the wiring harness and connectors are shaken, there is a poor contact in the wiring harness or connectors in that area.

8.3 Diagnosis Inspection Using The MIL (Malfunction Indicator Light)

- Before reading a DTC, turn the ignition switch ON to make sure the MIL (Malfunction Indicator Light) illuminates.
- Inspections in the check mode cannot be performed.

(1) Reading DTCs

Short circuiting the connector

- Using the STT, short circuit between DLC1 terminals 8 (TE1) and 3 (E1) or between DLC3 terminals 13 (TC) and 4 (CG).

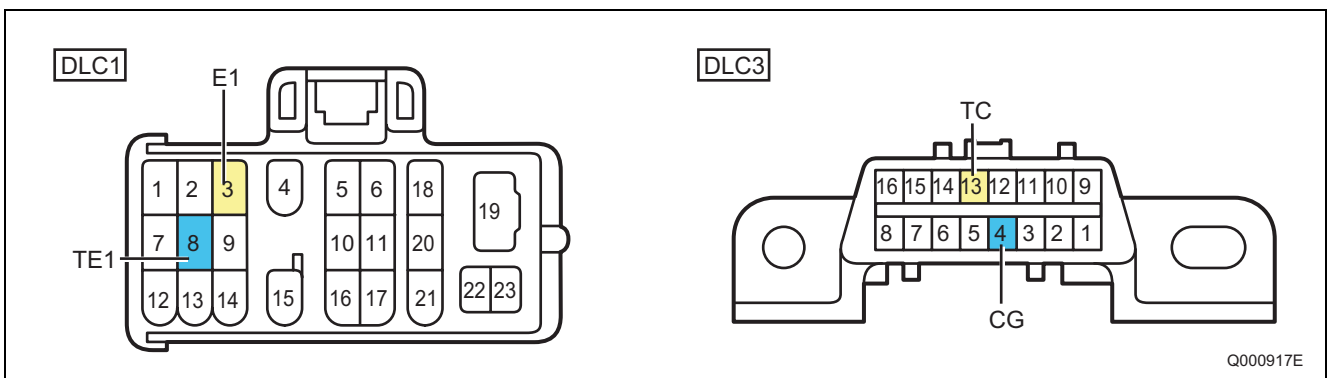

< CAUTION >

Never connect the wrong terminals of the connectors as this will lead to a malfunction.

Reading DTCs 1

- Turn the ignition switch ON and count the number of times the MIL (Malfunction Indicator Light) blinks

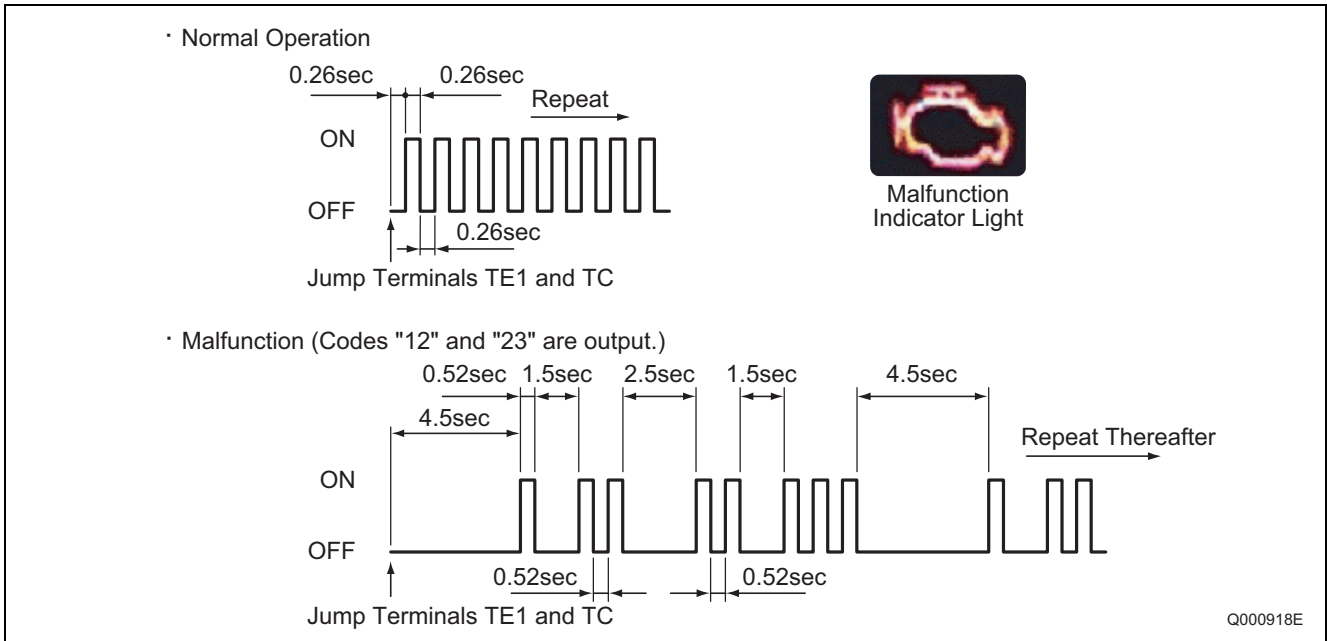
**< NOTE >**

- If the MIL (Malfunction Indicator Light) does not output a code (the light does not blink), there may be an open circuit in the TC terminal system or a failure in the engine ECU.
- If the malfunction indicator light is constantly ON, there may be a short (pinching) in the wiring harness or a failure in the engine ECU.
- If meaningless DTCs are output, there may be a malfunction in the engine ECU.
- If the MIL (Malfunction Indicator Light) illuminates without outputting a DTC while the engine operates at a minimum speed of 1000rpm, turn the ignition switch OFF once; then resume the inspection.

Reading DTCs 2

- If an abnormal DTC has been output, check it against the DTC list.

Erasing DTCs from memory

- Remove the ECD fuse (15A); after 15 seconds have elapsed, re-install the fuse.

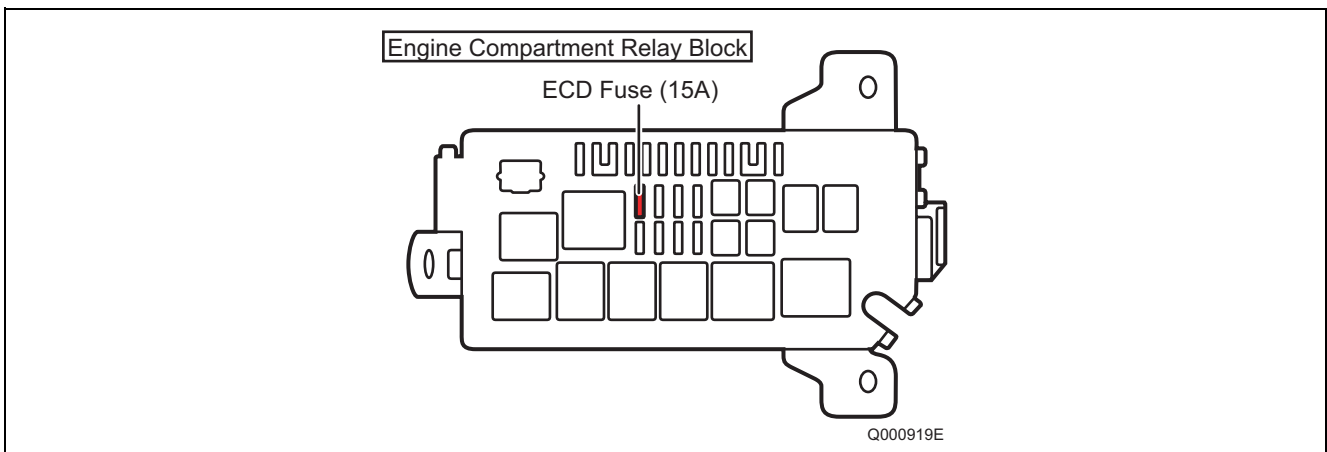
**< CAUTION >**

After completing the inspection of the ECD system, erase the DTC memory, and make sure the normal code is output.

8.4 Throttle Body Function Inspection

< CAUTION >

- Be sure to inspect the function of the throttle body after it has been disassembled and reassembled, or after any of its components have been removed and reinstalled.
- Verifying Throttle Motor: Verify that the motor generates an operating sound when the ignition switch is turned ON. Also, verify that there is no interference sound.

(1) Erasing DTCs

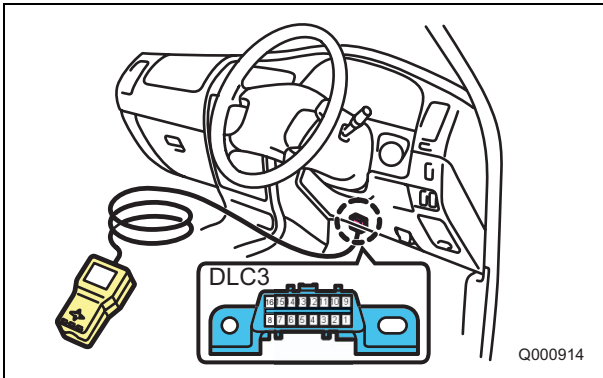

1) Connect the DST-1 to the DLC3 connector.

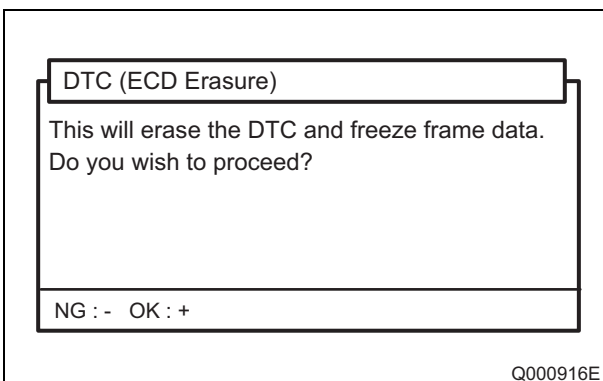

2) Operate in accordance with the instructions shown on the screen to display the "DTC check" screen. Select "Erase DTCs" to erase the DTCs.

(2) Inspection

- Start the engine and make sure the MIL (Malfunction Indicator Light) does not illuminate and the engine speed is within standards when the air conditioner is turned ON and OFF after the engine has warmed up.

< CAUTION >

Make sure no electrical load is applied.

(3) Final Inspection

- After inspecting the throttle body function, drive test the vehicle to confirm that operation is normal.

9. END OF VOLUME MATERIALS

9.1 Particulate Matter (PM)

- At high concentration levels, this substance is known to affect the respiratory system. It consists of soluble organic matter such as unburned oil, unburned diesel fuel, and other "soluble organic matter" in the exhaust gases, and insoluble organic matter such as soot (black smoke) and sulfuric acid gas.

9.2 Common Rail Type Fuel Injection System Development History And The World's Manufacturers

- The conventional injection pump faced certain issues such as injection pressure that depended on engine speed, and limits on the maximum fuel pressure. Other types of injection control such as pilot injection also faced some difficulties. Addressing these issues in a revolutionary manner, DENSO led the world by introducing a commercial application of the common rail fuel injection system.
- Two types of common rail fuel injection systems are in use today. One is the common rail system that pressurizes the fuel and injects it directly into the cylinders. DENSO was the first in the world to introduce a commercial application of this system. This system, which is undergoing further development, has been adopted in passenger car applications. Other companies, such as R. Bosch, Siemens, and Delphi also offer their commercial versions of this system today. The other system is the Hydraulic Electric Unit Injection (HEUI) system, which was developed by Caterpillar in the United States. This system uses pressurized engine oil to pressurize the fuel by actuating the piston of the nozzle (injector) through which the pressurized fuel is injected.

9.3 Higher Injection Pressure, Optimized Injection Rates, Higher Injection Timing Control Precision, Higher Injection Quantity Control Precision

(1) Higher Injection Pressure

- The fuel that is injected from the nozzle turns into finer particles as the fuel injection pressure increases. This improves combustion and reduces the amount of smoke contained in the exhaust gases. Initially, the maximum injection pressure of the in-line pump (A type) and the distributor pump (VE type) was 60 MPa. Due to advancement in high-pressure applications, there are some recently developed fuel injection systems that inject fuel at a pressure of 100 MPa or higher. The second-generation common rail system injects fuel at an extremely high pressure of 180 MPa.

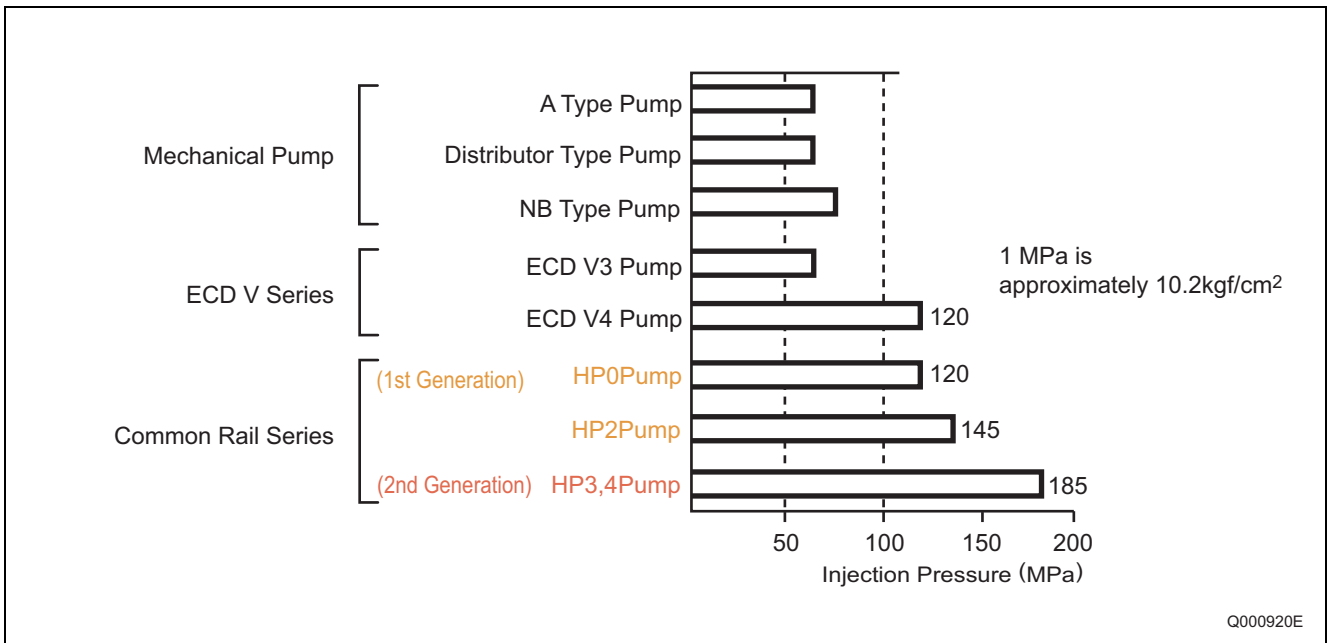

(2) Optimized Injection Rates

- The injection rate is the ratio of the changes in the fuel quantity that is injected successively from the nozzle within a given unit of time.

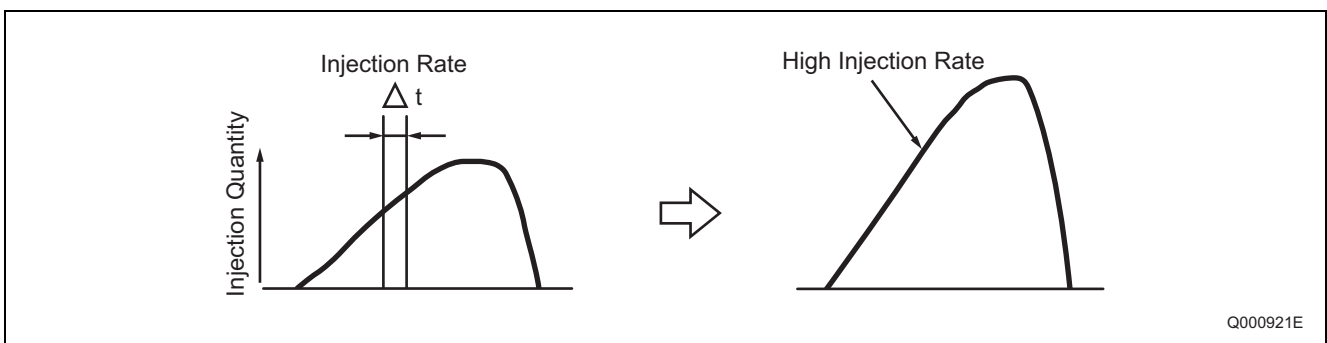

- As the injection pressure increases, the injection rate increases accordingly. The increase in injection rate leads to an increase in the volume of the air-fuel mixture that is created between the start of injection until ignition (the ignition lag period). Because this mixture is subsequently combusted at once, it creates noise (diesel knock) and NOx. For this reason, it is necessary to appropriately control the injection rate by maintaining a low injection rate at the beginning of injection and supplying a sufficient quantity after the ignition. To meet this need, two-spring nozzles have been adopted and a pilot injection system has recently been developed.

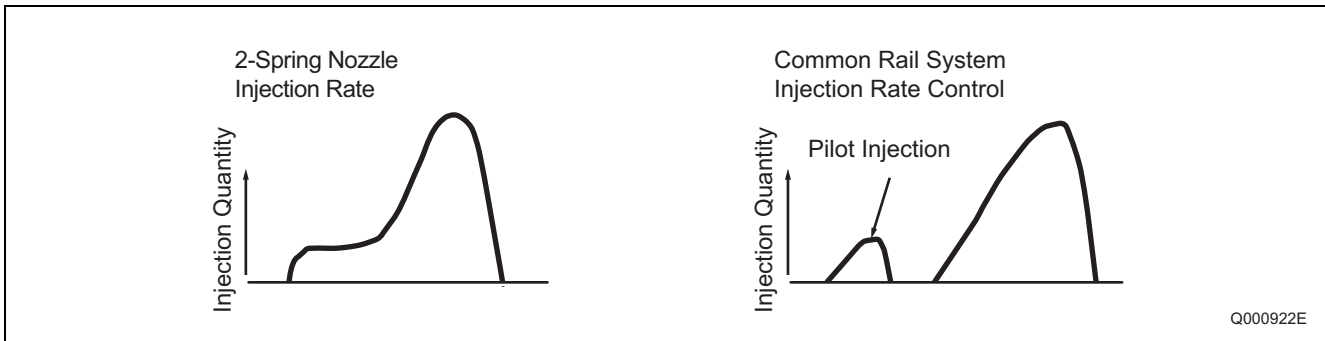

(3) Higher Injection Timing Control Precision

- Reducing exhaust gas emissions and fuel consumption and optimizing the injection timing are important. It is extremely difficult to achieve the desired exhaust emission reduction levels through methods that adjust the injection timing according to speed (or centrifugal force), such as the conventional mechanical timer. For this reason, electronically controlled systems have been adopted to freely and precisely control the injection timing in accordance with the engine characteristics.

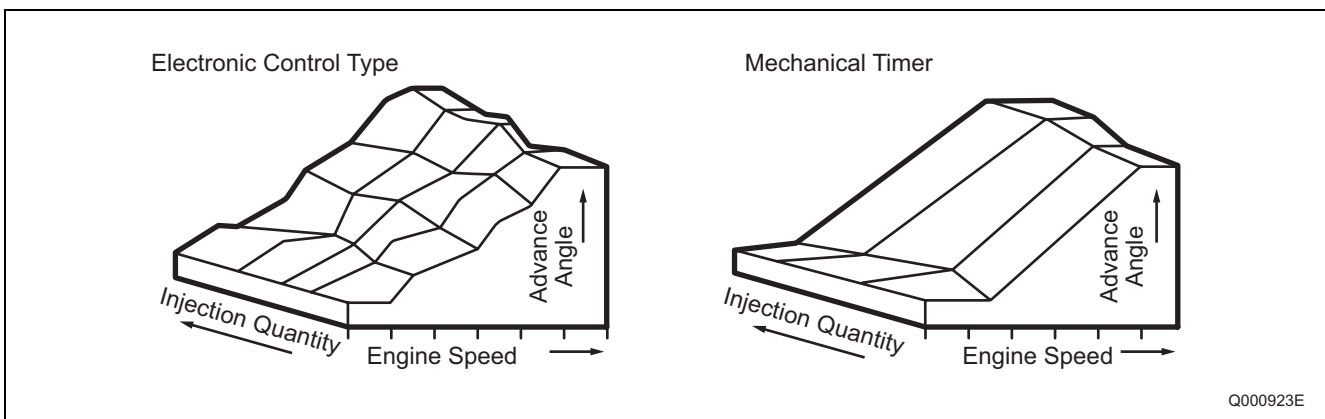

(4) Higher Injection Quantity Control Precision

- Power output adjustment in a diesel engine is accomplished by regulating the fuel injection quantity. Poor injection quantity control precision leads to increased exhaust gas emissions, noise, and poor fuel economy. For this reason, electronically controlled systems have been developed to ensure high precision injection quantity control.

9.4 Image Of Combustion Chamber Interior

- With conventional injection methods, because an excessive quantity of fuel was injected in the initial period, the explosion pressure rose excessively, leading to the generation of noise such as engine knocking sounds. To improve this condition through pilot injection, initially only the necessary and adequate quantity of fuel is injected. At the same time, the combustion chamber temperature is raised, and main injection combustion is assisted while working to prevent noise and vibration.

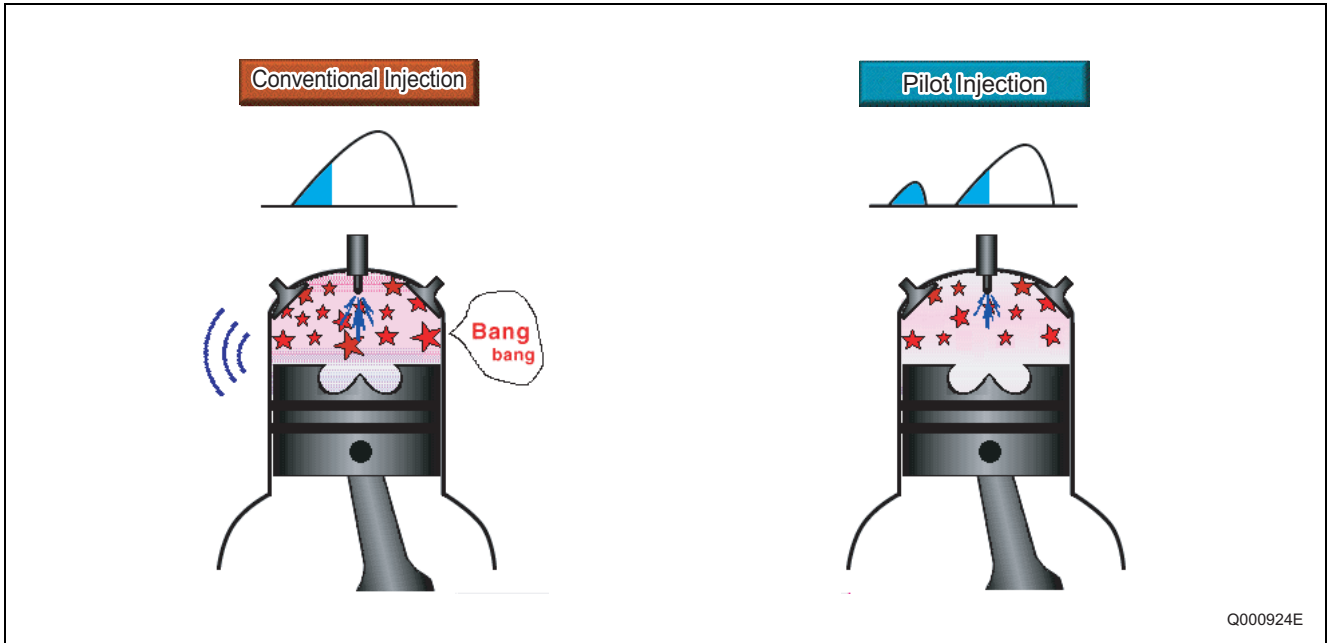

1. DIESEL ENGINE MALFUNCTIONS AND DIAGNOSTIC METHODS (BASIC KNOWLEDGE)

1.1 Combustion State and Malfunction Cause

- Depending on the state of combustion in a diesel engine, diesel knock as well as the color of the exhaust gas may change. Subsequently, the cause of engine malfunctions can be ascertained from changes in diesel knock and exhaust gas color.

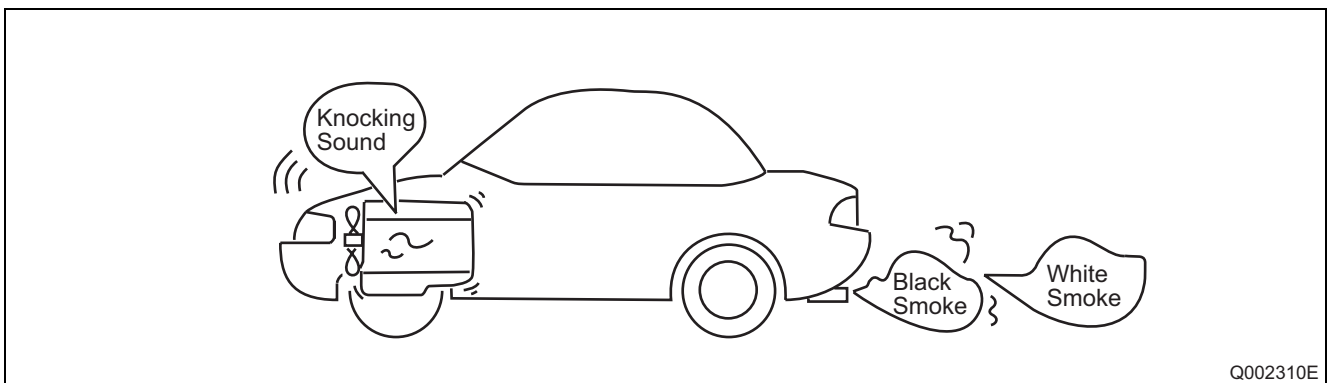

(1) Diesel Knock

- When fuel mixed with air during the ignition lag period (from the time injection begins until the fuel is ignited) reaches ignition temperature, the mixture is combusted in one burst. The pressure in the combustion chamber at this time rises as the quantity of the air-fuel mixture increases. If a large amount of air-fuel mixture is created during the ignition lag period, the pressure in the combustion chamber will rise rapidly. The pressure waves resulting from fuel ignition vibrate the cylinder walls and engine components, which generates noise. The generated noise is called "knocking". To some extent, knocking is unavoidable in engines that use a self-ignition system.

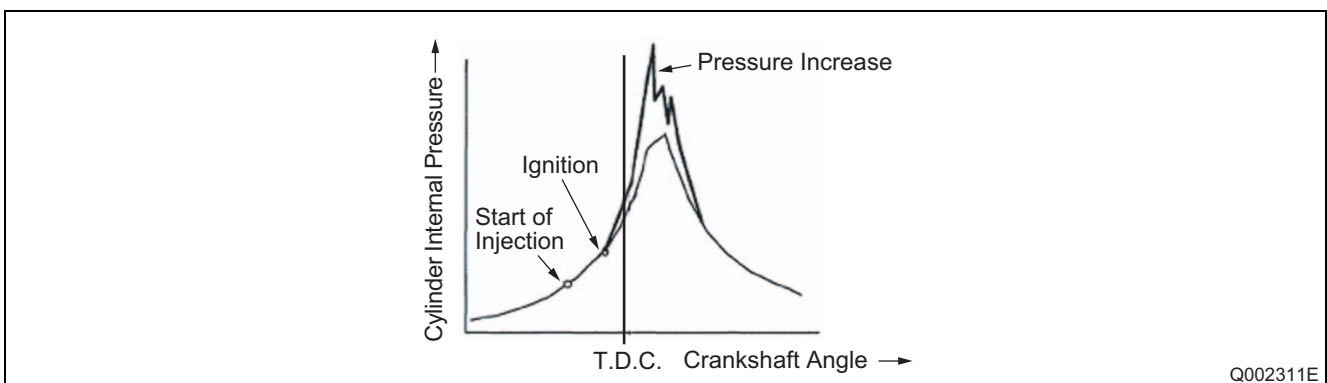

Cause of Diesel Knocking

1	Early Injection Timing	A large quantity of air-fuel mixture is created prior to ignition, or the cetane value is high.
2	Cold Engine	Ignition occurs late without an increase in temperature.
3	Intake air temperature is low.	
4	Poor Engine Compression	
5	Poor Fuel Combustibility	Ignition occurs late (low cetane value.)

(2) White Smoke

White smoke: Uncombusted fuel that has been vaporized and then discharged.

- White smoke is generated when combustion occurs at a relatively low temperature, resulting in the exhaust of uncombusted fuel and oil particles. White smoke is most likely to be generated when combustion chamber temperature is low.

Source of White Smoke

1	Late Injection Timing	Fuel is injected when the piston is in the down stroke.
2	Cold Engine	Ignition occurs late and combustion is prolonged.
3	Poor Fuel Combustibility	
4	Rise and Fall of Oil Pressure	Oil undergoes partial thermal breakdown.

(3) Black Smoke

Black smoke: Fuel that has been baked into soot and discharged.

- Black smoke is often referred to as just "smoke". Black smoke is generated when the injected fuel is poor in oxygen. As the fuel is exposed to high temperatures, thermal breakdown occurs, leaving carbon behind. Black smoke occurs when the injected fuel quantity is too large, or when the air-fuel mixture is rich due to an insufficient quantity of air.

Source of Black Smoke

1	Large Fuel Injection Quantity	Air-fuel mixture becomes rich.
2	Low Intake Air Quantity	Air quantity is insufficient due to air filter clogging.
3	Poor Fuel Atomization	The ratio of fuel to air worsens.
4	Retarded Fuel Injection Timing	Air-fuel mixing time is insufficient.

1.2 Troubleshooting

Troubleshooting cautions

- Observe the following cautions to avoid decreased engine performance and fuel injector malfunctions.
 - Use the designated fuel.
 - Avoid water and foreign material intrusion into the fuel tank.
 - Periodically check and clean the filter.
 - Do not unnecessarily disassemble sealed components.

Troubleshooting notes

- The cause of malfunctions is not necessarily limited to the pump itself, but may also be related to the engine and/or fuel systems. Further, the majority of malfunctions are the result of user error, and often can often be resolved through simple checks and maintenance. Avoid any hasty removal of system components.

Basic Check Items

1	Engine Oil	7	Fuel Supply to the Pump
2	Coolant	8	Injector Injection Status
3	Fan Belt	9	Supply Pump Timing Mark
4	Air Cleaner	10	Check for Loose or Disconnected Connectors, and Modifications
5	Battery and Terminals	11	Idle Speed Status
6	Fuel System Leaks		

2. DIAGNOSIS OVERVIEW

2.1 Diagnostic Work Flow

Diagnostic Procedures

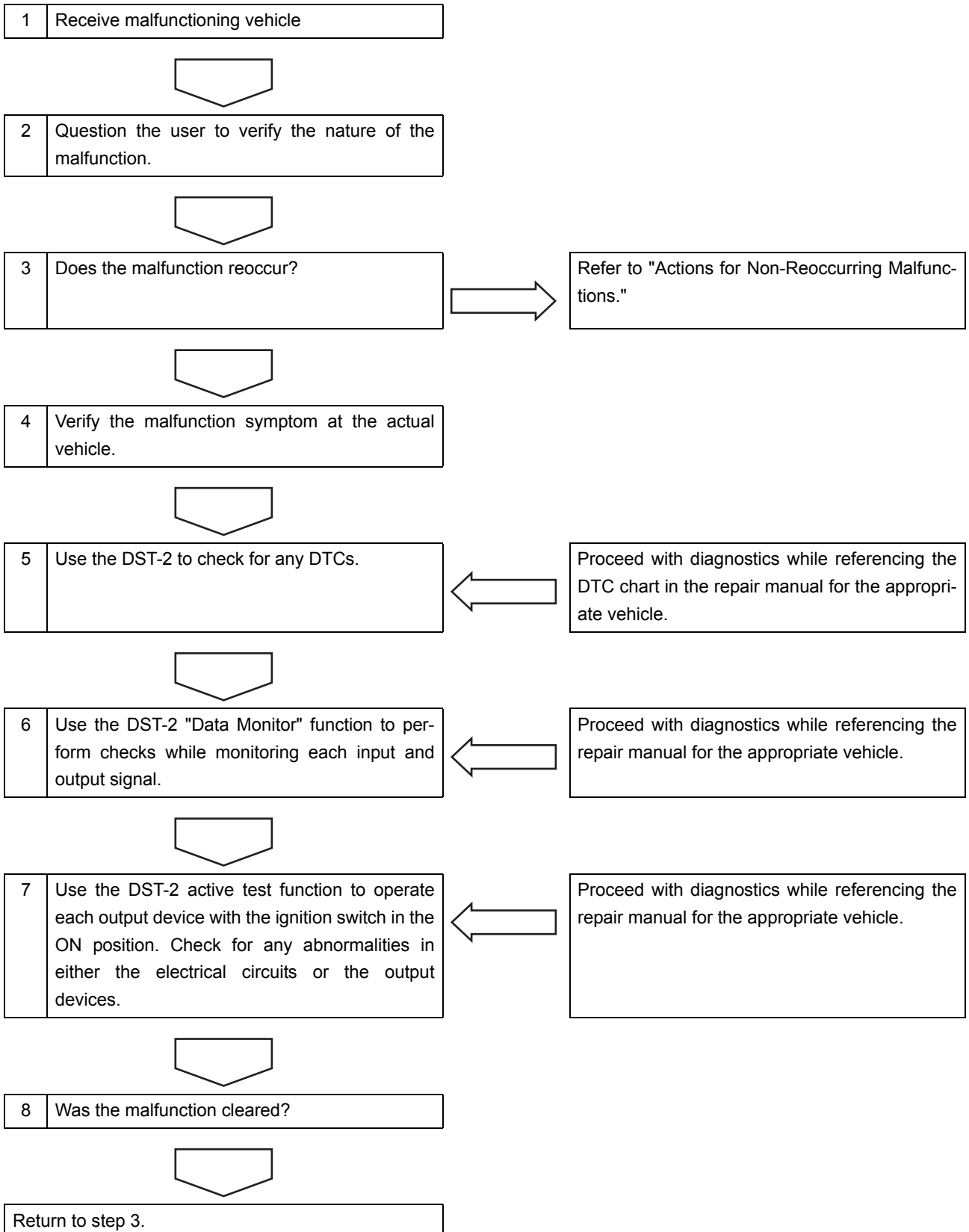

2.2 Inquiries

- Use the Common Rail System (CRS) troubleshooting questionnaire to consult with the customer and adequately grasp the malfunction symptoms.

< NOTE >

Do not ask random questions. Rather, ask questions that will aid in narrowing down the possible malfunctioning system while making educated guesses based on the actual symptoms.

Questioning points

- Use the following questions as a basis to fully grasp the malfunction.
 - What?: Malfunction symptoms
 - When?: Date, time, frequency of occurrence
 - Where?: Road conditions
 - Under what conditions?: Driving conditions, engine operating conditions, weather
 - How?: Impression of how the symptoms occurred.

CRS troubleshooting questionnaire

- When the vehicle is received at the service center, it is necessary to verify the "malfunction symptoms" and the "generated malfunction data" with the customer. Consult with the customer using the CRS troubleshooting questionnaire. The troubleshooting questionnaire is necessary for the following reasons.

Reasons

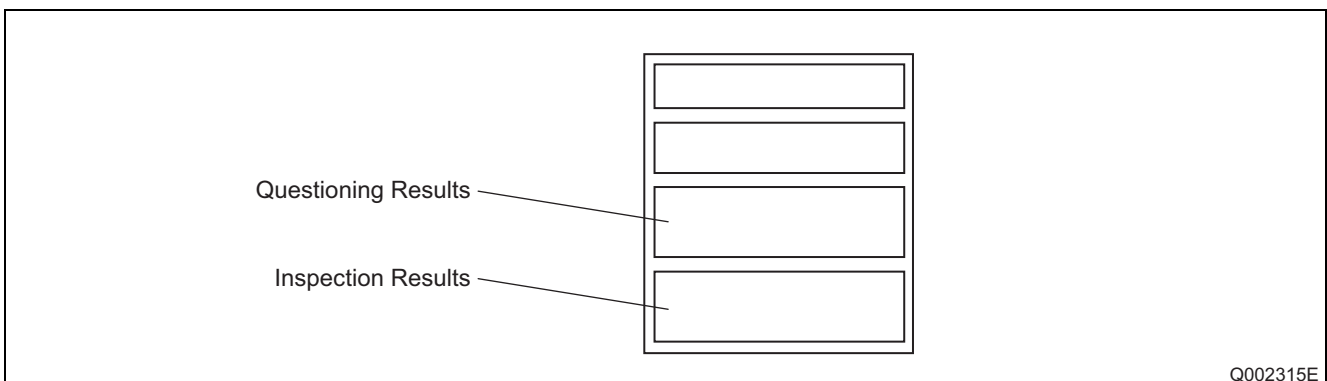

- There are cases when the malfunction symptoms cannot be reproduced at the service center.
- The customer's complaint is not always limited to the malfunction.
- If the person performing repairs is not working from the correct malfunction symptoms, man-hours will be wasted.
- The questionnaire can aid the service center in diagnosing, repairing and verifying repair work.



Q002315E

2.3 Non-Reoccurring Malfunctions

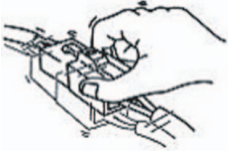
- In cases where the malfunction does not reoccur, perform the actions below to determine the cause of the malfunction.

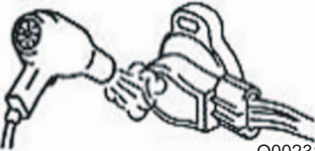
Action	Malfunction Symptom		
	Fully Dis-charged Battery	Engine will not Start	Idle Speed, Engine Stall, Sputtering, Poor Acceleration
Verify that there is no DTC stored in the memory.	No	Yes	Yes
Use the questionnaire as a basis to perform a reoccurrence test in "Reoccurrence" mode. Use this data (engine ECU voltage value, etc.) to determine the cause of the malfunction.	Yes	Yes	Yes
 <p>Q002317</p> <p>Assume that an electrical system wiring harness or connector is the cause of the malfunction. Shake the wiring by hand to check whether a malfunction occurs and a DTC is generated.</p>	No	Yes	Yes
<p>Assume that an electrical system female connector terminal is the cause of the malfunction and verify that the connection points are not defective.</p>  <p>Recommended Tool: KOWA Precision Handling Feeler Gauge Set (KLM-10-20) Depending on the terminal, a matching size may not be available</p> <p>Insert the male terminal that matches the shape of the female terminal and check for looseness. Q002318</p>	No	Yes	Yes
 <p>Q002319</p> <p>Use a dryer to heat the accelerator pedal position sensor and other electronic components. Check for changes in the voltage value (resistance value).</p> <p>< CAUTION ></p> <ul style="list-style-type: none"> • Do not exceed 60°C (still touchable by hand) when heating. • Do not remove the component cases and add heat directly to electronic parts. 	No	No	Yes
Verify whether malfunction symptoms occur under heavy engine loads (headlights, A/C, wiper, etc. switches ON.)	No	No	Yes
If any commercial electrical products have been installed, remove such products and verify whether the malfunction symptoms occur.	Yes	Yes	Yes

Action	Malfunction Symptom		
	Fully Discharged Battery	Engine will not Start	Idle Speed, Engine Stall, Sputtering, Poor Acceleration
<p>Mist State</p>  <p>Q002320E</p> <p>If it is likely that the malfunction occurs in rainy or high-temperature weather, spray the vehicle with water and verify whether the malfunction occurs.</p> <p>< CAUTION ></p> <ul style="list-style-type: none"> • Do not spray water directly into the engine compartment. Spray water in mist form on all surfaces of the radiator to indirectly change temperature and humidity. • Do not spray water directly on electrical parts. 	No	Yes	Yes

3. DTC READING (FOR TOYOTA VEHICLES)

3.1 DST-2

- The DST-2 can check for DTCs in either normal or check mode. In comparison to the normal mode, the check mode has higher sensitivity in detecting malfunctions. Check mode is used when detection is not possible in normal mode, regardless of the assumed abnormality.

3.2 DTC Check (Code Reading via the DST-2)

- Connect the DST-2 to the DLC3 connector.
- Operate the DST-2 in accordance with the instructions shown on the display to view the "DTC check" screen. Select either the normal or check mode to verify the DTC.

3.3 DTC Memory Erasure (via the DST-2)

- To erase DTC codes, follow the instructions on the display to view the "DTC and Freeze Data Erasure" screen.

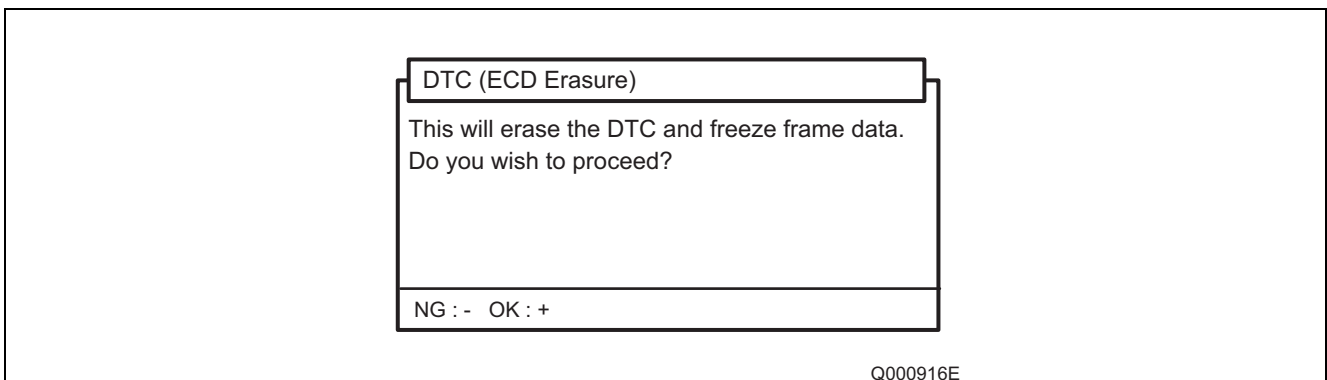

< CAUTION >

- If the DTC cannot be erased, cycle the ignition switch OFF and back ON, and then perform code erasure again.
 - Do not use the DST-2 to erase the DTC until the cause of the malfunction is clear.
-

4. TROUBLESHOOTING BY SYSTEM

4.1 Intake System Diagnosis

Clogged air cleaner element

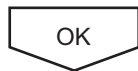
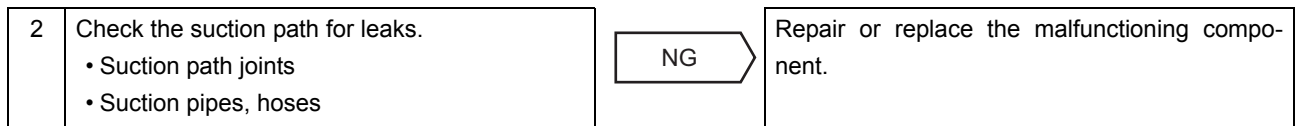

Normal

4.2 Fuel System Diagnosis

Clogged air cleaner element

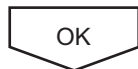
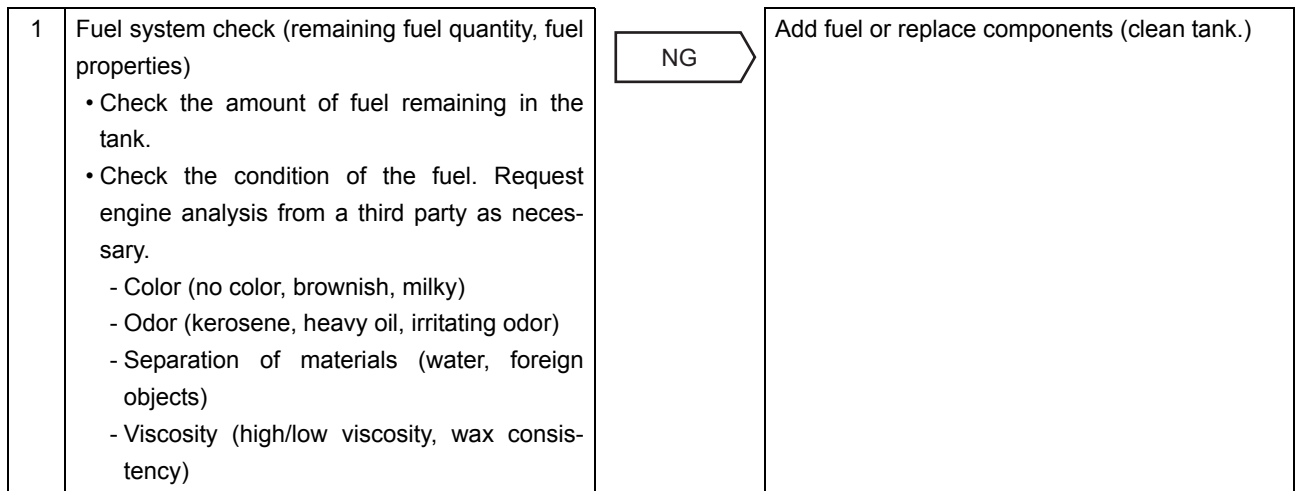

2 Fuel tank interior check (modification/additions, position of fuel pipe inlet/outlet, clogging and holes)

- Check the tank for modifications or additions. Consult with the user.
 - Fuel inlet/outlet position, tank piping
 - Foreign material inside the tank, water separation
 - Tank-internal Zn cladding
 - Check the tank-internal fuel piping for the following.
 - Inlet/outlet position (below position "E")
 - Inlet clogging, bent or deformed piping (crushed pipe)
 - Crushed piping connections

NG

Restore the fuel tank.

OK

3 Tank-external fuel path conditions (crushed hose, clogging, air introduction at hose connection)

- Check the condition of the hose.
 - Crushing around bands, over-bending
 - Pinched or crushed by other parts
- Air introduction through fuel system connection points
 - Looseness
 - Hose deterioration (Verify by hand or visually that there is no rubber hardening/splitting.)

< CAUTION >

Be cautious when vacuum pressure is present, as air will be drawn into the hose.

NG

Repair or replace the hose.

OK

4 Primary filter, sedimentor check

- Check for primary filter clogging and dirt.
- Check sedimentor water volume.

NG

Replace the filter, and drain water from the sedimentor.

OK

5 Looseness at priming attachment point check

- Check the following.
 - Looseness at the priming attachment point
 - Does the piston stick out?
 - Fuel leakage (oozing)

NG

Tighten or replace the priming pump.

OK

6 Filter (supply pump inlet) clogging

- Fuel filter
 - Check for fuel delivery from the priming pump.
- Gauze filter
 - Visually check for clogging due to foreign material.

NG

Clean the gauze filter, fuel filter and fuel piping system, or replace the filters.

OK

7 Oil level increase (engine internal leak)

- Verify whether the oil level increases on the oil level gauge.

NG

Check the engine.

OK

8 High-pressure piping and CRS component (injector supply pump, rail) fuel leaks (engine external leak) (Refer to "(2) Fuel leak check".)

- Connect the DST-2 to the diagnostic connector. Activate the "Fuel Leak Check Function" within the active test.
- Visually check and specify areas that leak fuel.

< CAUTION >

In the event of a large fuel leak downstream of the flow damper, be aware that fuel flow will stop and the leak will cease due to flow damper operation.

NG

Repair leaking high-pressure piping or replace leaking parts.

OK

Normal

(1) Fuel pressure test procedure

- Connect the DST-2 to the vehicle-side test connector.
 - With the vehicle idling, verify the rail pressure displayed on the DST-2.

System selection screen: Rail a ECU Data Monitor

Item Name (Abbreviated)	Explanation	Check Conditions	Reference Value	Items of Importance During an Abnormality
Rail Pressure (RP)	<ul style="list-style-type: none"> • Displays the fuel pressure in the rail. • Display range: 0 MPa to 255 MPa 	Following engine warm-up, when the engine is rotating	Fuel pressure in the rail is displayed within a range of 30 MPa to 160 MPa.	PCR1, PCR2 signals (rail assembly)

(2) Fuel leak check

- Connect the DST-2 to the vehicle-side test connector.
- With the vehicle idling, perform the active test by following the instructions on the DST-2 display.

System selection screen: TCCS a Active Test

Item Name	Description	Control Conditions
High-Pressure Fuel System Check	Raise engine speed to 2000 rpm, and then use the active test to place the fuel inside the rail under high pressure. <u>< CAUTION ></u> Engine speed cannot be raised by stepping on the accelerator pedal.	<ul style="list-style-type: none"> • Following engine warm-up, when the engine is at idle speed • The vehicle speed sensor is operating normally, and speed is 0 km/h.

- Verify that there are no fuel system leaks during the active test (when fuel pressure is being applied to the rail.)

4.3 Basics of Electrical/Electronic Circuit Checks

(1) ECU terminal voltage and waveform measurements

- When measuring the voltage and resistance of each terminal, insert the multimeter probe into the rear side of the wiring harness connector. If connectors are too small for the probe to be inserted easily, insert a fine metal wire into the rear of the connector and touch the wire to the probe.

< NOTE >

The number of each terminal can be seen from the rear side of the wiring harness.

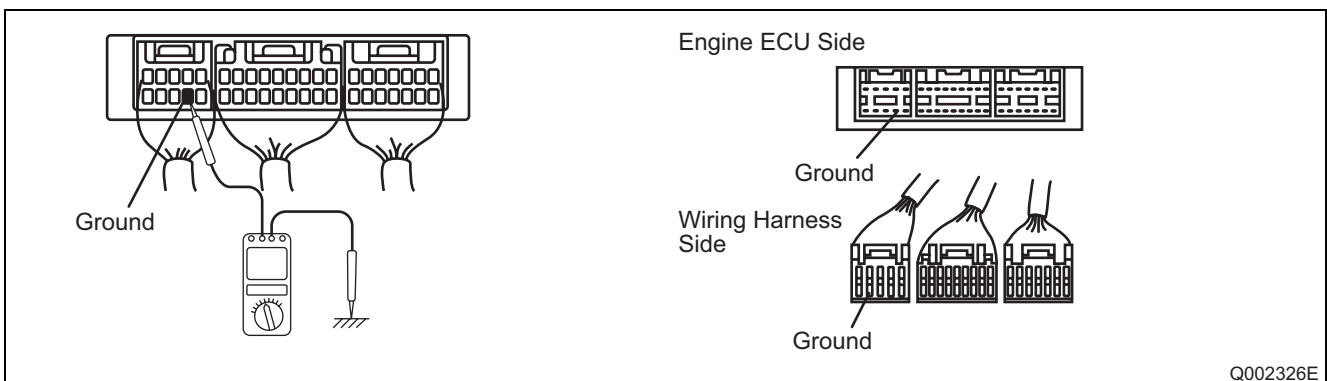

Q002326E

(2) Open circuit check

- When dealing with a wiring harness open circuit like that depicted in diagram 1, check continuity and/or voltage to determine the location of the open circuit.

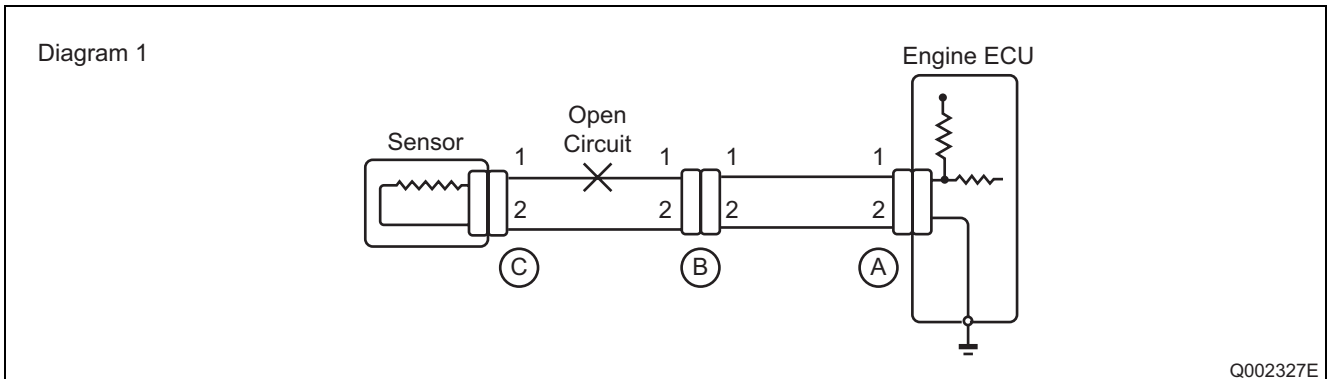

Continuity Check

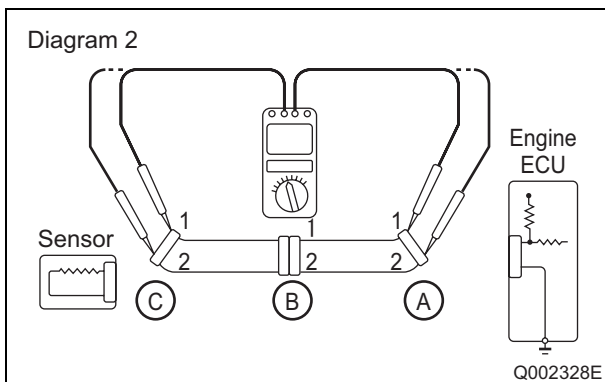

- 1) Remove connectors "A" and "C", and then measure resistance between the two.

Standard Value	1Ω or less
----------------	------------

< NOTE >

Measure resistance while gently shaking the wiring harness up and down, and side-to-side.

- 2) As shown in diagram 2, there is no continuity (open circuit) between terminal 1 of connector "A" and terminal 1 of connector "C". However, there is continuity between terminal 2 of connector "A" and terminal 2 of connector "C". Therefore, there is an open circuit between terminal 1 of connector "A" and terminal 1 of connector "C".

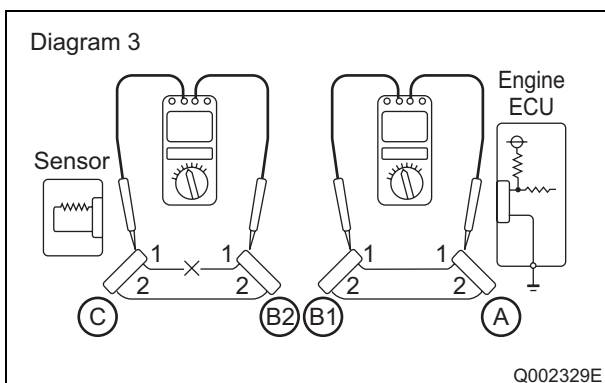

- 3) Remove connector "B" and measure the connector resistance.
- 4) As shown in diagram 3, there is continuity between terminal 1 of connector "A" and terminal 1 of connector "B1". However, there is no continuity (open circuit) between terminal 1 of connector "B2" and terminal 1 of connector "C". Therefore, there is an open circuit between terminal 1 of connector "B2" and terminal 1 of connector "C".

Voltage Check

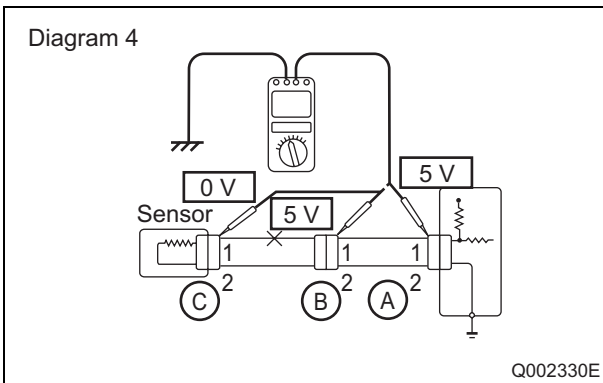

- 1) For the circuit that applies voltage to the ECU connector terminals, check for an open circuit by performing a voltage check.
- 2) As shown in diagram 4, with all connectors connected, measure the voltage for the ECU 5 V output terminal between the body ground and terminal 1 of connector "A". Next measure voltage for terminal 1 of connector "B" and terminal 1 of connector "C" in the same fashion.
- 3) The faulty circuit and measurement results are shown below.

Measurement Results	<ul style="list-style-type: none"> • Voltage between terminal 1 of connector "A" and the body ground is 5 V. • Voltage between terminal 1 of connector "B" and the body ground is 5 V. • Voltage between terminal 1 of connector "C" and the body ground is 0 V.
Faulty Item	There is an open circuit in the wiring harness between terminal 1 of connector "B" and terminal 1 of connector "C".

(3) Short circuit check

- As shown in diagram 5, if there is a short in the wiring harness ground, perform a "Ground Continuity Check" to determine the cause of the short.

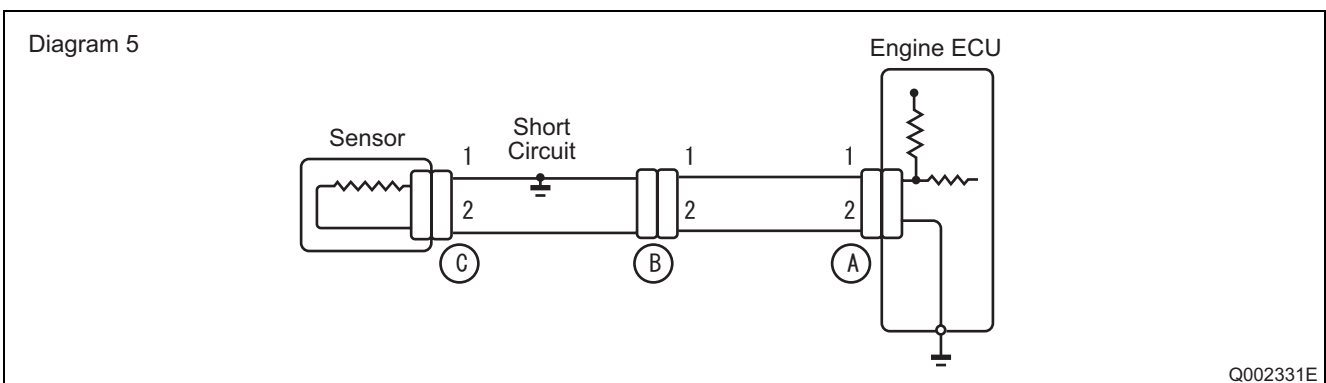

Ground Continuity Check

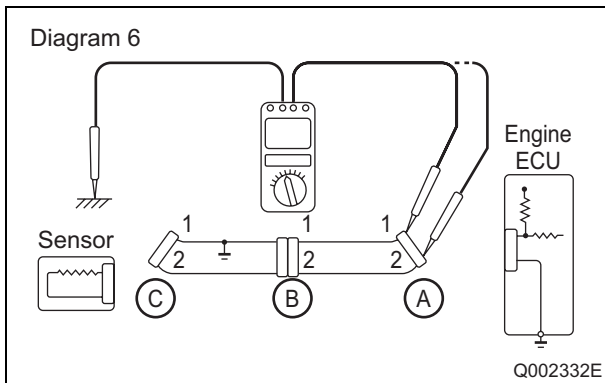

- 1) Remove connector "A" and connector "C", and then measure the resistance respectively between terminals 1 and 2 of connector "A" and ground.

Standard Value	1Ω or less
----------------	------------

< NOTE >

Measure resistance while gently shaking the wiring harness up and down, and side-to-side.

- 2) As shown in diagram 6, there is continuity between terminal 1 of connector "A" and the body ground (short circuit). However, there is no continuity between terminal 2 of connector "A" and the body ground. Therefore, there is a short circuit between terminal 1 of connector "A" and terminal 1 of connector "C".

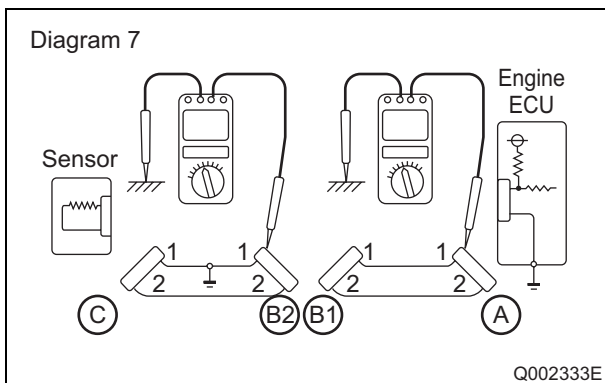

- 3) Remove connector "B" and measure the resistance between terminal 1 of connector "A" and the body ground, and between terminal 1 of connector "B2" and the body ground.

- 4) The faulty circuit and measurement results are shown below.

Measurement Results	<ul style="list-style-type: none"> • There is no continuity between terminal 1 of connector "A" and the body ground. • There is continuity between terminal 1 of connector "B2" and the body ground.
Faulty Item	There is a short circuit between terminal 1 of connector "B2" and terminal 1 of connector "C".

(4) Connector connection fault verification method

- Simultaneously perform the data monitor and connector voltage measurements.

Ex.) Coolant temperature sensor

1. Read the "Coolant Temperature Output Voltage" value using the DST-2 data monitor.
2. Measure the voltage directly from the corresponding ECU terminal.

If "1" is unsatisfactory and "2" is satisfactory, the connector connection is judged as faulty. Since some malfunctions only occur intermittently, measure voltage while pulling and shaking the wires in order to try to get the malfunction to reoccur.

Voltage Measurement

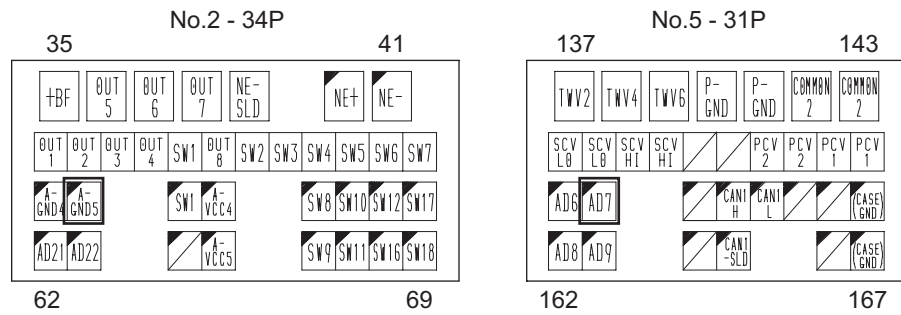

5. TROUBLESHOOTING

5.1 Troubleshooting According to Malfunction Symptom (for TOYOTA Vehicles)

(1) Malfunction Indicator Lamp (MIL) is lit.

Description
The check engine warning light is lit when the engine is running, or before the engine is started.

Possible Cause
The DTC is recorded in the engine ECU.

Clogged air cleaner element

1	Connect the DST-2 and read the DTC.	NG	Inspect the check engine warning light circuit.
---	-------------------------------------	----	---

OK

Troubleshoot the corresponding DTC.

(2) The engine is hard to start.

Description
The starter turns at normal speed, but the engine takes too long to start.

Possible Cause
<ul style="list-style-type: none"> • Start signal circuit • Glow control system • Crankshaft position sensor • Engine ECU power supply circuit • Injector • Supply pump • Cylinder recognition sensor

Clogged air cleaner element

1	Use the DST-2 to verify whether the coolant temperature is at the glow system operating temperature. In addition, verify whether battery voltage is being supplied to the glow plugs at the designated times.	NG	Repair the glow control system. (Refer to the glow control system check procedure issued by the vehicle manufacturer.)
---	---	----	--

OK

2	Use the DST-2 to monitor engine speed while cranking the engine. Verify whether engine speed is being correctly output.	NG	Check the crankshaft position sensor. (Refer to the crankshaft position sensor check procedure issued by the vehicle manufacturer.)
---	---	----	---

OK

3 Verify the output waveform of the cylinder recognition sensor. (Refer to the cylinder recognition sensor check procedure issued by the vehicle manufacturer.)

NG

Repair or replace the cylinder recognition sensor and/or the corresponding circuit.

OK

4 Check each injector. (Refer to the injector check procedure issued by the vehicle manufacturer.)

NG

Repair or replace the injector and/or the corresponding circuit.

OK

5 Verify whether there is a start signal when cranking the engine by checking the engine ECU start signal terminal.

NG

Repair the start signal circuit.

OK

6 Check the engine ECU power supply. (Refer to the engine ECU power supply circuit diagram issued by the vehicle manufacturer.)

NG

Repair the engine ECU power supply.

OK

7 Check the supply pump and the supply pump drive circuit. (Refer to the supply pump drive circuit diagram issued by the vehicle manufacturer.)

NG

Repair or replace the supply pump and drive circuit.

OK

Troubleshooting complete

(3) The engine stalls when idling.

Description
The engine stalls after starting or when idling.

Possible Cause
<ul style="list-style-type: none"> • Crankshaft position sensor • Engine ECU power supply circuit • Injector • Supply pump • Engine cooling system • Start signal circuit

Clogged air cleaner element

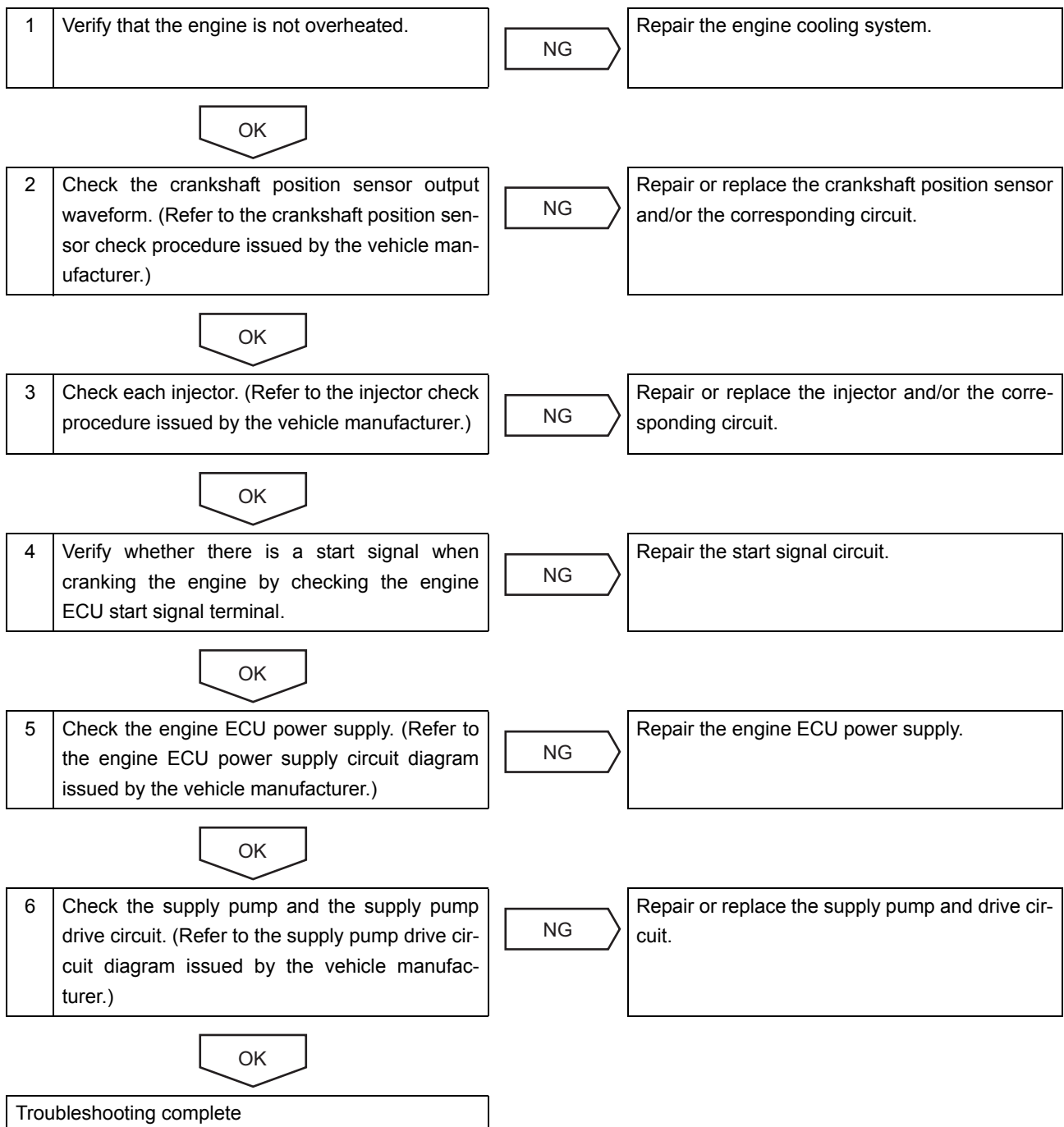

(4) The engine cranks normally, but does not start.

Description
The engine is cranked at the normal speed, but does not start.

Possible Cause
<ul style="list-style-type: none"> • Crankshaft position sensor • Engine ECU power supply circuit • Injector • Supply pump • Start signal circuit

Clogged air cleaner element

1	Use the DST-2 to verify whether the coolant temperature is at the glow system operating temperature. In addition, verify whether battery voltage is being supplied to the glow plugs at the designated times.	NG	Repair the glow control system. (Refer to the glow control system check procedure issued by the vehicle manufacturer.)
OK			
2	Monitor engine speed while cranking the engine. Verify whether engine speed is being correctly output.	NG	Check the crankshaft position sensor. (Refer to the crankshaft position sensor check procedure issued by the vehicle manufacturer.)
OK			
3	Verify whether there is a start signal when cranking the engine by checking the engine ECU start signal terminal.	NG	Repair the start signal circuit.
OK			
4	Check the engine ECU power supply. (Refer to the engine ECU power supply circuit diagram issued by the vehicle manufacturer.)	NG	Repair the engine ECU power supply.
OK			
5	Check each injector. (Refer to the injector check procedure issued by the vehicle manufacturer.)	NG	Repair or replace the injector and/or the corresponding circuit.
OK			
6	Check the supply pump and the supply pump drive circuit. (Refer to the supply pump drive circuit diagram issued by the vehicle manufacturer.)	NG	Repair or replace the supply pump and drive circuit.
OK			
Troubleshooting complete			

(5) Idle instability following engine start

Description
Idle speed after starting the engine is abnormal.

Possible Cause
<ul style="list-style-type: none"> • Injector • Supply pump • Fuel filter • Engine ECU • Rail pressure sensor

Clogged air cleaner element

1	Check each injector. (Refer to the injector check procedure issued by the vehicle manufacturer.)	NG	Repair or replace the injector and/or the corresponding circuit.
---	--	----	--

OK

2	Check the fuel filter.	NG	Replace the fuel filter.
---	------------------------	----	--------------------------

OK

3	Check the supply pump and the supply pump drive circuit. (Refer to the supply pump drive circuit diagram issued by the vehicle manufacturer.)	NG	Repair or replace the supply pump and drive circuit.
---	---	----	--

OK

4	Check the rail pressure sensor and the corresponding circuit. (Refer to the rail pressure sensor check procedure issued by the vehicle manufacturer.)	NG	Repair or replace the rail pressure sensor and the corresponding circuit.
---	---	----	---

OK

Troubleshooting complete

(6) The engine returns to idle speed too slowly, or does not return at all.**Description**

The time required for the engine to return to idle speed is longer than normal, or the engine does not return to idle speed.

Possible Cause

- Accelerator position sensor
- Injector
- Supply pump

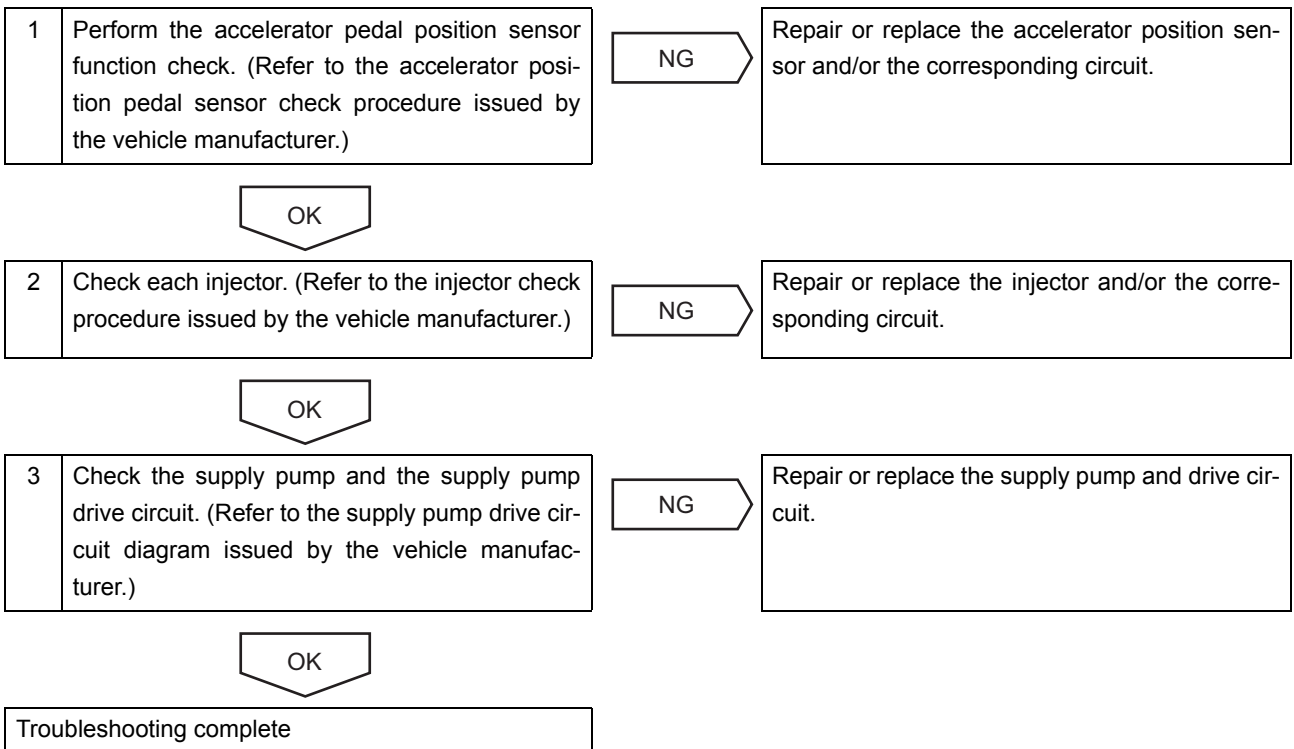
Clogged air cleaner element

(7) Rough idle

Description
Idle speed fluctuates, causing the engine to vibrate.

Possible Cause
<ul style="list-style-type: none"> • Engine cooling system • Crankshaft position sensor • Engine • Supply pump • Injector

Clogged air cleaner element

1	Check parts that may be a source of abnormal engine vibration.	NG	Repair the engine.
---	--	----	--------------------

OK

2	Check each injector. (Refer to the injector check procedure issued by the vehicle manufacturer.)	NG	Repair or replace the injector and/or the corresponding circuit.
---	--	----	--

OK

3	Verify that the engine is not overheated.	NG	Repair the engine cooling system.
---	---	----	-----------------------------------

OK

4	Check the crankshaft position sensor. (Refer to the crankshaft position sensor check procedure issued by the vehicle manufacturer.)	NG	Repair or replace the crankshaft position sensor and/or the corresponding circuit.
---	---	----	--

OK

5	Check the supply pump and the supply pump drive circuit. (Refer to the supply pump drive circuit diagram issued by the vehicle manufacturer.)	NG	Repair or replace the supply pump and drive circuit.
---	---	----	--

OK

Troubleshooting complete

(8) The engine stalls when decelerating.**Description**

The engine suddenly stops when decelerating.

Possible Cause

- Engine cooling system
- Crankshaft position sensor
- Engine ECU power supply circuit
- Supply pump
- Injector
- Start signal circuit

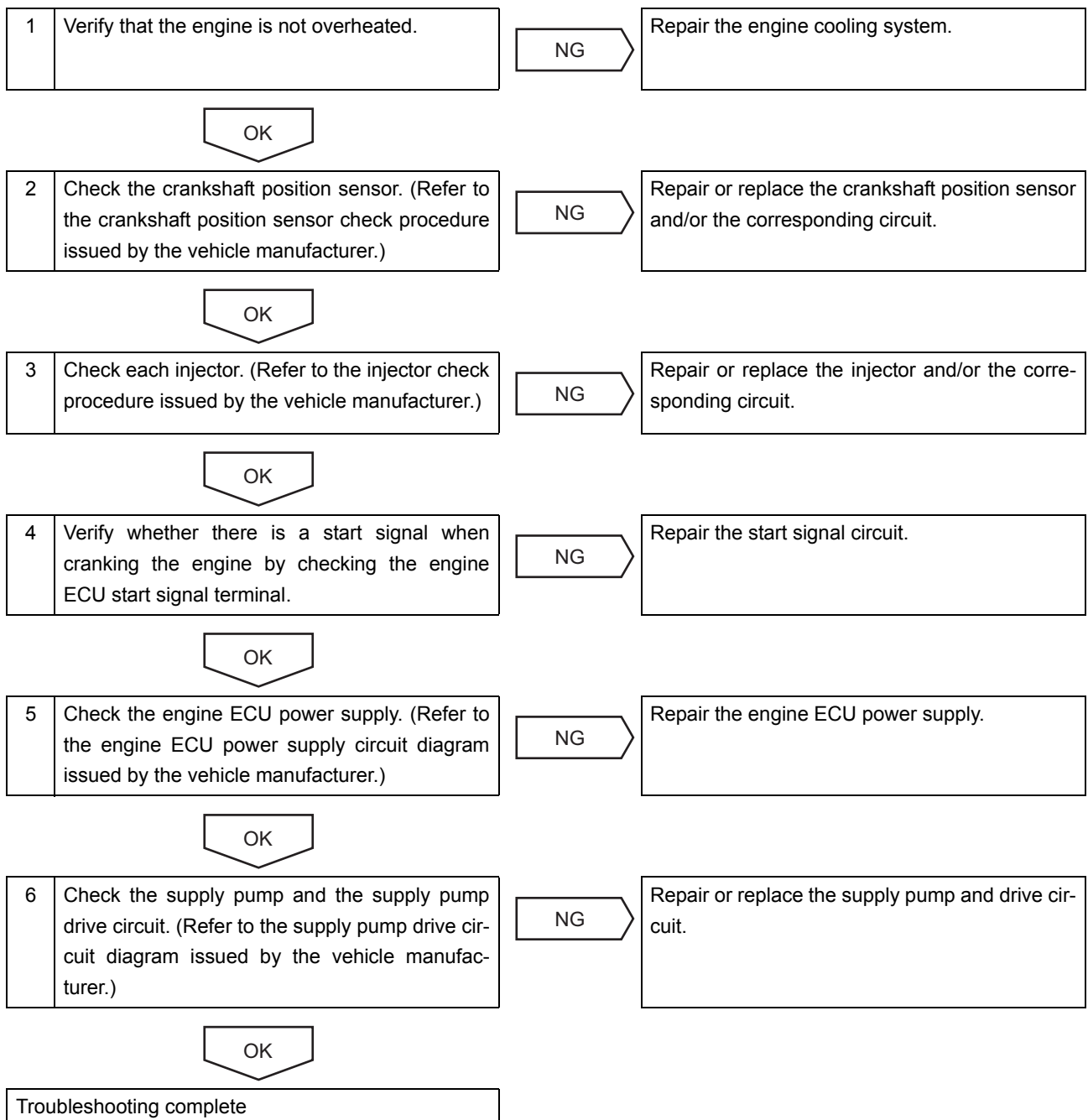
Clogged air cleaner element

(9) Poor engine output, poor acceleration

Description
Deficient engine performance.

Possible Cause
<ul style="list-style-type: none"> • EGR system • Injector • Mass Air Flow (MAF) meter • Crankshaft position sensor • Accelerator position sensor • Boost pressure sensor • Supply pump • Start signal circuit • Air cleaner, duct

Clogged air cleaner element

1	Check for air cleaner clogging and/or damage.	NG	Replace the air cleaner or repair the air duct.
---	---	----	---

OK

2	Verify that the engine is not overheated.	NG	Repair the engine cooling system.
---	---	----	-----------------------------------

OK

3	Check the crankshaft position sensor. (Refer to the crankshaft position sensor check procedure issued by the vehicle manufacturer.)	NG	Repair or replace the crankshaft position sensor and/or the corresponding circuit.
---	---	----	--

OK

4	Check each injector. (Refer to the injector check procedure issued by the vehicle manufacturer.)	NG	Repair or replace the injector and/or the corresponding circuit.
---	--	----	--

OK

5	Verify whether there is a start signal when cranking the engine by checking the engine ECU start signal terminal.	NG	Repair the start signal circuit.
---	---	----	----------------------------------

OK

6	Check the MAF meter and the corresponding circuit. (Refer to the MAF meter check procedure issued by the vehicle manufacturer.)	NG	Repair or replace the MAF meter and/or the corresponding circuit.
---	---	----	---

OK

7	Check the Exhaust Gas Recirculation (EGR) system. (Refer to the EGR system check procedure issued by the vehicle manufacturer.)	NG	Repair or replace the EGR system.
OK			
8	Perform the accelerator pedal position sensor function check. (Refer to the accelerator position pedal sensor check procedure issued by the vehicle manufacturer.)	NG	Repair or replace the accelerator position sensor and/or the corresponding circuit.
OK			
9	Check the boost pressure sensor and the corresponding circuit. (Refer to the boost pressure sensor check procedure issued by the vehicle manufacturer.)	NG	Repair or replace the boost pressure sensor and/or the corresponding circuit.
OK			
10	Check the supply pump and the supply pump drive circuit. (Refer to the supply pump drive circuit diagram issued by the vehicle manufacturer.)	NG	Repair or replace the supply pump and drive circuit.
OK			
Troubleshooting complete			

(10) Knocking, abnormal noise

Description
Abnormal combustion occurs, and a knocking sound is generated.

Possible Cause
<ul style="list-style-type: none"> • Engine • Injector • Glow control system • Crankshaft position sensor

Clogged air cleaner element

1	Repair the glow control system. (Refer to the glow control system check procedure issued by the vehicle manufacturer.)	NG	Repair the glow control system.
---	--	----	---------------------------------

OK

2	Check the crankshaft position sensor. (Refer to the crankshaft position sensor check procedure issued by the vehicle manufacturer.)	NG	Repair or replace the crankshaft position sensor and/or the corresponding circuit.
---	---	----	--

OK

3	Check each injector. (Refer to the injector check procedure issued by the vehicle manufacturer.)	NG	Repair or replace the injector and/or the corresponding circuit.
---	--	----	--

OK

4	Check engine parts that may be a source of abnormal combustion.	NG	Repair the engine.
---	---	----	--------------------

OK

Troubleshooting complete

(11) Poor fuel economy**Description**

More fuel than normal is being consumed.

Possible Cause

- Engine
- Injector
- Supply pump

Clogged air cleaner element

1	Check each injector. (Refer to the injector check procedure issued by the vehicle manufacturer.)	NG	Repair or replace the injector and/or the corresponding circuit.
OK			
2	Check the supply pump and the supply pump drive circuit. (Refer to the supply pump drive circuit diagram issued by the vehicle manufacturer.)	NG	Repair or replace the supply pump and drive circuit.
OK			
3	Check parts that may be a source of poor fuel economy.	NG	Repair the engine.
OK			
Troubleshooting complete			

(12) Black Smoke

Description
Black smoke is being exhausted.

Possible Cause
<ul style="list-style-type: none"> • Injector • Supply pump • EGR system • Engine ECU • Electronic control throttle • Rail pressure sensor • Mass Air Flow (MAF) meter • Boost pressure sensor

Clogged air cleaner element

1	Check for air cleaner clogging and/or damage.	NG	Replace the air cleaner or repair the air duct.
---	---	----	---

OK

2	Check the electronic control throttle and the corresponding circuit. (Refer to the electronic control throttle check procedure issued by the vehicle manufacturer.)	NG	Repair or replace the electronic control throttle and/or the corresponding circuit.
---	---	----	---

OK

3	Check the MAF meter and the corresponding circuit. (Refer to the MAF meter check procedure issued by the vehicle manufacturer.)	NG	Repair or replace the MAF meter and/or the corresponding circuit.
---	---	----	---

OK

4	Check the Exhaust Gas Recirculation (EGR) system. (Refer to the EGR system check procedure issued by the vehicle manufacturer.)	NG	Repair or replace the EGR system.
---	---	----	-----------------------------------

OK

5	Check the boost pressure sensor and the corresponding circuit. (Refer to the boost pressure sensor check procedure issued by the vehicle manufacturer.)	NG	Repair or replace the boost pressure sensor and/or the corresponding circuit.
---	---	----	---

OK

6	Check the rail pressure sensor and the corresponding circuit. (Refer to the rail pressure sensor check procedure issued by the vehicle manufacturer.)	NG	Repair or replace the rail pressure sensor and the corresponding circuit.
---	---	----	---

OK

7	Check each injector. (Refer to the injector check procedure issued by the vehicle manufacturer.)	NG	Repair or replace the injector and/or the corresponding circuit.
---	--	----	--

OK

8	Check the engine ECU power supply. (Refer to the engine ECU power supply circuit diagram issued by the vehicle manufacturer.)	NG	Repair the engine ECU power supply.
---	---	----	-------------------------------------

OK

9	Check the supply pump and the supply pump drive circuit. (Refer to the supply pump drive circuit diagram issued by the vehicle manufacturer.)	NG	Repair or replace the supply pump and drive circuit.
---	---	----	--

OK

Troubleshooting complete

(13) White smoke

Description
White smoke is being exhausted.

Possible Cause
<ul style="list-style-type: none"> • Fuel filter • Injector • Supply pump • EGR system • Engine ECU • Electronic control throttle • Rail pressure sensor

Clogged air cleaner element

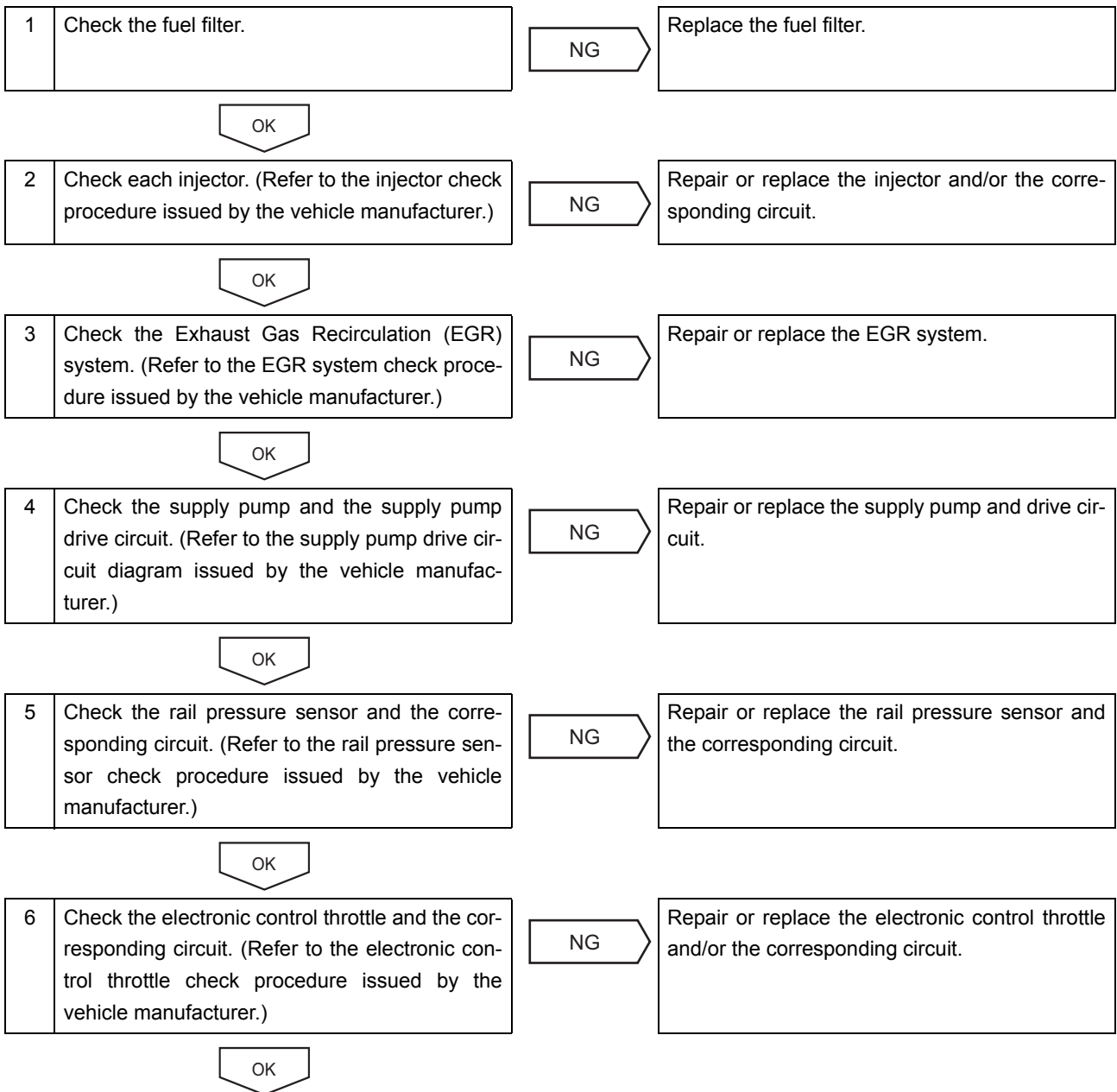

Troubleshooting complete

5.2 Other Malfunction Symptoms

Malfunctions caused by components other than the CRS

- There are occasions when a malfunction that appears to be generated by the CRS is actually caused by a different component or system. For instance, engine mechanical parts and the fuel system may cause malfunction symptoms identical to symptoms generated by the CRS. When troubleshooting, do not simply assume that the source of a malfunction is the CRS. Consider all causes should be exhaustively considered while verifying the list below.

Malfunction Symptom	Faulty Item	Cause	Action
Insufficient Power	Intake system	Clogged air cleaner element	Clean or replace the air cleaner element.
	Fuel system	Air mixed with the fuel system	Perform fuel system air bleeding.
		Faulty fuel filter	Replace the filter.
		Insufficient fuel	Add fuel and perform fuel system air bleeding.
		Improper fuel	Switch to the correct fuel.
	Engine	Compression pressure abnormality	Refer to the engine repair manual.
		Piston, cylinder liner and/or piston ring	
Other	Overheat		
Faulty starting	Intake system	Clogged air cleaner element	Clean or replace the air cleaner element.
	Fuel system	Insufficient fuel	Add fuel and perform fuel system air bleeding.
		Improper fuel	Replace the filter.
		Fuel system clog	Clean the fuel system.
		Air introduction through fuel system connection points	Tighten all connections.
		Fuel filter clog	Replace the fuel filter.
		Loose injection piping connections	Tighten connecting nuts.
	Electrical system	Faulty battery	Check the battery.
		Faulty starter wiring	Replace the starter wiring.
Loose battery cables		Tighten the battery terminal connections, or replace the cables.	
Faulty starting	Electrical system	Faulty starter operation	Replace the starter assembly.
		Faulty glow plug system	Replace the glow plugs.
	Lubrication system	Excessive engine oil viscosity	Replace with oil of appropriate viscosity.
	Engine	Burnt pistons	Replace the piston, piston ring and cylinder liner.
		Burnt bearings	Replace the bearing and crankshaft.
		Low compression pressure	Overhaul the engine.
Other	Ring gear damage	Replace the ring gear and/or starter pinion gear.	

Malfunction Symptom	Faulty Item	Cause	Action
Faulty idling	Engine	Poor valve clearance	Adjust the valve clearance or replace the bearing.
		Poor valve seat contact	Break in, or replace the valve and valve seat.
		Low coolant temperature	Perform warm-up operation.
		Large difference in cylinder-to-cylinder compression pressure	Overhaul the engine.

6. DIAGNOSIS CODES (DTC)

6.1 DTC Chart (Example)

DTC Structure

- P####: Powertrain-related (engine, drive system)
- U####: Network-related (vehicle communication)

DTC Assignment

- PO###: Determined by SAE/ISO
- P1###: Determined by manufacturer
- P2###: Determined by manufacturer
- P3###: Mixture of items determined by SAE/ISO and items determined by the vehicle manufacturer.

DTC Chart (example for HINO and TOYOTA vehicles)

- DTC codes that apply to the CRS are listed below (compatible with the DST-2.)

DTC	DTC Description
P0006	Fuel shutoff valve "A" control circuit low voltage
P0007	Fuel shutoff valve "A" control circuit high voltage
P0016	Crankshaft position sensor, cylinder recognition sensor correlation
P0030	A/F sensor heater control circuit
P0031	A/F sensor heater control circuit low voltage
P0032	A/F sensor heater control circuit high voltage
P0036	A/F sensor heater control circuit
P0037	A/F sensor heater control circuit low voltage
P0045	Turbo/supercharger control solenoid open circuit
P0049	Turbo/supercharger overspeed
P0087	Fuel/rail pressure too low
P0088	Fuel/rail pressure too high
P0093	Fuel system leak maximum quantity detection
P0095	Intake air temperature sensor 2, circuit related
P0097	Intake air temperature sensor 2 circuit low voltage
P0098	Intake air temperature sensor 2 circuit high voltage
P0100	Mass Air Flow (MAF) meter, circuit related
P0101	MAF meter circuit range/performance
P0102	MAF meter circuit low input
P0103	MAF meter circuit high input
P0105	Boost pressure sensor, circuit related
P0107	Boost pressure sensor circuit low input
P0108	Boost pressure sensor circuit high input
P0112	Boost pressure sensor 1 circuit low voltage
P0113	Boost pressure sensor 1 circuit high voltage
P0115	Coolant temperature sensor, circuit related
P0117	Coolant temperature sensor circuit low voltage

DTC	DTC Description
P0118	Coolant temperature sensor circuit high voltage
P0119	Coolant temperature sensor circuit intermittent operation
P0120	Accelerator position sensor, switch "A" circuit related
P0121	Accelerator position sensor switch "A" circuit range/performance
P0122	Accelerator position sensor switch "A" circuit low voltage
P0123	Accelerator position sensor switch "A" circuit high voltage
P0124	Accelerator position sensor switch "A" circuit intermittent operation
P0168	Fuel temperature too high
P0180	Fuel temperature sensor, "A" circuit related
P0181	Fuel temperature sensor "A" circuit range/performance
P0182	Fuel temperature sensor "A" circuit low voltage
P0183	Fuel temperature sensor "A" circuit high voltage
P0184	Fuel temperature sensor "A" circuit intermittent operation
P0185	Fuel temperature sensor, "B" circuit related
P0186	Fuel temperature sensor "B" circuit range/performance
P0187	Fuel temperature sensor "B" circuit low voltage
P0188	Fuel temperature sensor "B" circuit high voltage
P0189	Fuel temperature sensor, "B" circuit intermittent operation
P0190	Rail pressure sensor, circuit related
P0191	Rail pressure sensor circuit range/performance
P0192	Rail pressure sensor circuit low voltage
P0193	Rail pressure sensor circuit high voltage
P0194	Rail pressure sensor circuit intermittent operation
P0200	Injector open circuit
P0201	Injector open circuit- #1 cylinder
P0202	Injector open circuit- #2 cylinder
P0203	Injector open circuit- #3 cylinder
P0204	Injector open circuit- #4 cylinder
P0205	Injector open circuit- #5 cylinder
P0206	Injector open circuit- #6 cylinder
P0208	Injector open circuit- #8 cylinder
P0217	Engine overheat
P0218	Transmission overheat
P0219	Engine overrun
P0230	Fuel pump, primary circuit related
P0234	Turbo/supercharger overboost
P0237	Boost pressure sensor circuit low voltage
P0263	Cylinder correction quantity error- #1 cylinder
P0266	Cylinder correction quantity error- #2 cylinder
P0269	Cylinder correction quantity error- #3 cylinder
P0272	Cylinder correction quantity error- #4 cylinder

DTC	DTC Description
P0275	Cylinder correction quantity error- #5 cylinder
P0278	Cylinder correction quantity error- #6 cylinder
P0299	Turbo/supercharger supercharge deficiency
P0335	Crankshaft position sensor, "A" circuit related
P0339	Crankshaft position sensor "A" circuit intermittent operation
P0340	Cylinder recognition sensor, "A" circuit related
P0400	EGR flow volume abnormality
P0404	EGR control circuit range/performance
P0405	EGR sensor "A" circuit low voltage
P0406	EGR sensor "A" circuit high voltage
P0407	EGR sensor "B" circuit low voltage
P0408	EGR sensor "B" circuit high voltage
P0500	Vehicle speed sensor, "A" circuit related
P0501	Vehicle speed sensor "A" circuit range/performance
P0504	Brake switch "A", "B" correlation
P0510	Throttle position switch closed
P0524	Engine oil pressure too low
P0540	Intake air heater "A" circuit
P0544	Exhaust gas temperature sensor, circuit related
P0545	Exhaust gas temperature sensor circuit low voltage
P0546	Exhaust gas temperature sensor circuit high voltage
P0560	Battery voltage
P0605	Engine ECU internal malfunction
P0607	Engine ECU internal malfunction
P0611	EDU malfunction
P0617	Starter relay circuit high voltage
P0627	Fuel pump "A" open control circuit
P0686	Engine ECU power supply relay control circuit low voltage
P0704	Clutch switch input circuit abnormality
P0710	Transmission oil temperature sensor, "A" circuit related
P0715	Turbine speed sensor, "A" circuit related
P0753	Shift solenoid "A" actuation related
P0758	Shift solenoid "B" actuation related
P0850	Parking/neutral switch, input circuit related
P2002	Particulate Matter (PM) capture efficiency at or below specified value
P2031	Exhaust gas temperature sensor, circuit related
P2032	Exhaust gas temperature sensor circuit low voltage
P2033	Exhaust gas temperature sensor circuit high voltage
P2047	Exhaust gas fuel addition valve abnormality
P2120	Accelerator position sensor, switch "D" circuit related
P2121	Accelerator position sensor switch "D" circuit range/performance

DTC	DTC Description
P2122	Accelerator position sensor, switch "D" circuit low input
P2123	Accelerator position sensor, switch "D" circuit high input
P2125	Accelerator position sensor, switch "E" circuit related
P2127	Accelerator position sensor, switch "E" circuit low input
P2128	Accelerator position sensor, switch "E" circuit high input
P2138	Accelerator position sensor, switch "D"/"E" circuit voltage correlation
P2226	Atmospheric pressure sensor, circuit related
P2228	Atmospheric pressure sensor circuit low voltage
P2229	Atmospheric pressure sensor circuit high voltage

Published : August 2004

Second Issu: September 2007

Edited and published by:

DENSO CORPORATION

Service Department

1-1 Showa-cho, Kariya, Aichi Prefecture, Japan