

Valve Size	DIMENSIONS													
	A		B		C		ØD		ØE		F		APPROX. WEIGHT	
	IN	MM	IN	MM	IN	MM	IN	MM	IN	MM	IN	MM	LB	KG
3"	11.50	292	4.56	116	8.88	226	7.69	195	3.19	81	.94	24	56	25
4"	14.25	362	5.94	151	9.94	253	9.12	232	4.25	108	1.00	25	90	41
6"	15.75	400	6.75	171	10.69	271	11.12	282	6.25	159	1.06	27	136	62
8"	17.36	441	9.38	238	14.00	356	13.37	340	8.25	210	1.12	28	247	112

PARTS LIST	
NO.	Description
1	Body
2	Cover
3	Plug
4	Cover Bearing
5	Body Bearing
6	Cover O-Ring
7	Cover Bolts
8	Grit Excluder Seal
9	Thrust Bearing
10	Packing
11	Gland
12	Gland Studs
13	Gland Nuts
14	Key
19	Torque Collar
20	Opening Limit Screw
21	Closing Limit Screw
22	Collar Screw
23	Collar Washer
24	Torque Adjuster

NOTES:
 1. FLANGE DRILLING PER ANSI A21.1 AWWA C111
 2. IN COMPLIANCE WITH AWWA C517
 3. COLD WORKING PRESSURE: 175 PSI
 4. HYDROSTATIC TEST PRESSURE: 265 PSI

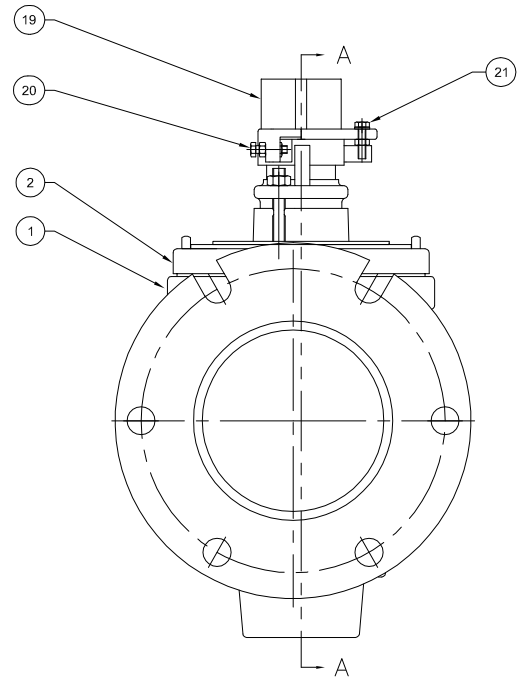
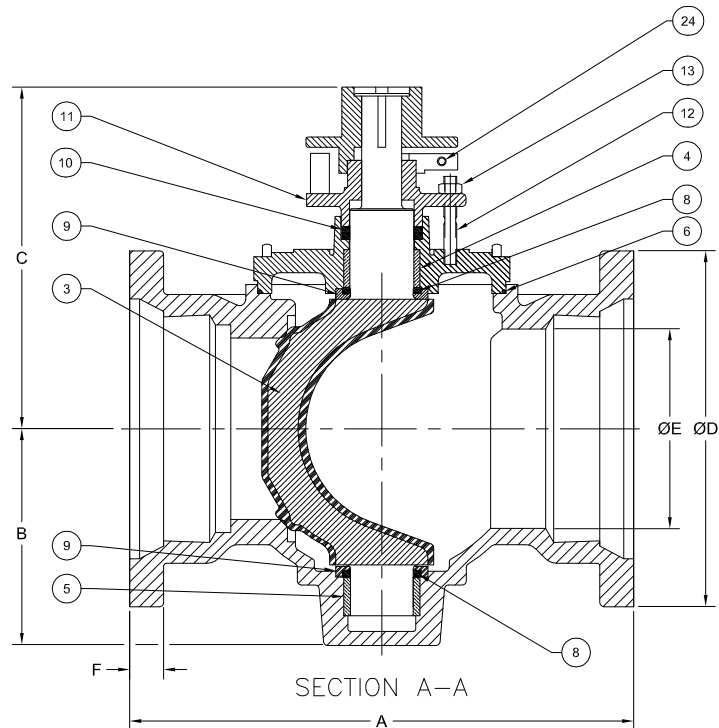
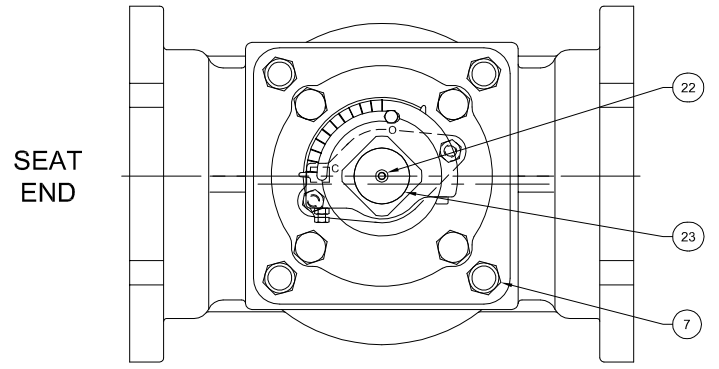

GA INDUSTRIES, LLC		DIMENSIONS IN INCHES		SERIAL NO.	DRAWN BY
STANDARD TOLERANCES UNLESS OTHERWISE NOTED		CASTING STOCK UNLESS OTHERWISE NOTED		FIG. NUMBER	APPR. BY
FRACTIONS ± .005		DECIMALS ± .005		B517	JT
ANGLES ± .5°		HOLE POSITION ± .010		DATE	SCALE
HOLE POSITION ± .010		HOLE POSITION ± .010		10-16-2014	N.T.S.
HOLE POSITION ± .010		HOLE POSITION ± .010		PROPERTY OF GA INDUSTRIES, LLC	
HOLE POSITION ± .010		HOLE POSITION ± .010		REFERENCES	FILE
HOLE POSITION ± .010		HOLE POSITION ± .010		PL	DRAWING NO.
HOLE POSITION ± .010		HOLE POSITION ± .010		PL-2013	REV.
HOLE POSITION ± .010		HOLE POSITION ± .010		A	A

REV.	DESCRIPTION	DATE	BY
A	ADDED PARTS 22, 23, & 24	02-26-2015	BRF

J:\AutoCAD\Plug\PL-Show\PL-2013-A.dwg