

PARTS LIST	
NO.	NAME
1	BODY
2	DISC
3	SEAT
4	SHAFT
5	TAPER PIN
6	NUT
7	WASHER
8	SEAL
9	UPPER BEARING
10	UPPER SHAFT PACKING
11	UPPER PACKING WASHER
12	RETAINER
13	KEY
14	LOWER BEARING
15	LOWER SHAFT PACKING
16	LOWER PACKING WASHER
17	GASKET
18	BOTTOM COVER
19	CAP SCREW
20	CENTERING SCREW
21	LOCK NUT
22	WORM GEAR OPERATOR
23	ACTUATOR SCREWS
24	ACTUATOR WASHERS

- TECHNICAL REQUIREMENTS:
- DESIGN STANDARD, AWWA C504
  - FLANGE DRILLING PER ANSI B16.1 CLASS 125 FOR BOTH CLASS 150B AND 250B VALVES.
  - DIMENSIONS IN INCHES, WEIGHT IN POUNDS. DOES NOT INCLUDE ACTUATOR.
  - WORKING PRESSURE 150 PSI OR 250 PSI BASED ON CLASS.
  - SHAFT DIAMETER AND BODY WALL THICKNESS PER AWWA C504.

SIZE	A	B	C	F (TYP.)	ØG	#-ØH	K	M	ØN	MTG.	WGT.
14"	8	10.56	14.00	3.00	18.75	12-φ1 1/8	15.28	9.21	12.00	FA12	352
12"	8	9.50	12.31	2.00	17.00	12-φ1	13.59	9.21	12.00	FA12	223
10"	8	8.06	10.75	1.00	14.25	12-φ1	12.03	9.21	12.00	FA12	157
8"	6	6.75	9.50	1.00	11.75	8-φ7/8	10.81	9.09	12.00	FA12	108
6"	5	5.88	8.00	0.50	9.50	8-φ7/8	9.31	9.09	12.00	FA12	68
4"	5	4.50	7.00	—	7.50	8-φ3/4	8.34	9.09	12.00	FA07	51
3"	5	3.75	6.25	—	6.00	4-φ3/4	7.59	9.09	12.00	FA07	42

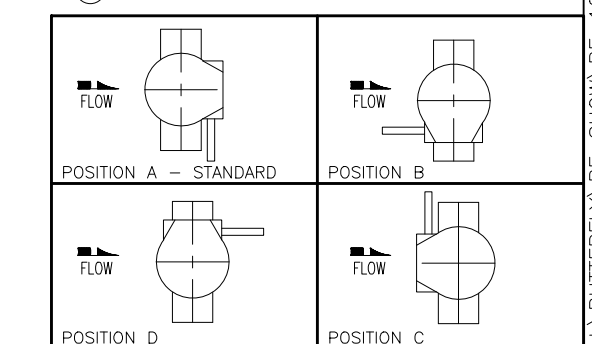

**GA INDUSTRIES, LLC.**

3"-14" ANSI FLANGED BUTTERFLY VALVE  
W/WORM GEAR ACTUATOR

SERIAL NO.	SCALE	DRAWN BY	
	N.T.S.	HGM	
REFERENCES	EFFECTIVE DATE	APPR. BY	
	10-02-2009 TO	JT	
FIG. NUMBER	FILE	DRAWING NO.	REV.
804	BF	BF-1015	

STANDARD TOLERANCES (UNLESS OTHERWISE NOTED)  
FINISHED SURFACES ONLY  
DIMENSIONS SHOWN IN INCHES  
± = 0.02  
± = 0.01  
± = 0.005  
FRACTIONS ±1/64"  
ANGLES ±1°  
FINISH ±0.005

REV.	DESCRIPTION	DATE	BY

J:\BUTTERFLY\BF-SHOW\BF-1015.DWG