

NOTICE OF PONTIAC CITY COUNCIL MEETING
October 27, 2020
at 6:00 p.m.

THE MEETING WILL BE HELD ELECTRONICALLY

The City Council of the City of Pontiac will hold a Formal Meeting on October 27, 2020 at 6:00 p.m. This meeting will be held electronically as allowed by the amended Open Meetings Act. The agenda of the Formal Meeting is attached. The Pontiac City Council gives notice of the following:

1. **Procedures.** The public may view the meeting electronically through the following method.
<http://pontiac.mi.us/council/pontiactv/index.php>
2. **Public Comment.** For individuals who desire to make a public comment, please submit your name and comment in writing to publiccomments@pontiac.mi.us. Additionally, you may submit your public comment in writing directly to the Office of the City Clerk during regular business hours. All public comments must be received no later than 5:30 p.m. on October 27, 2020. Public comments are limited to three (3) minutes. The City Clerk will read your comments during the public comment section of the meeting.
3. **Persons with Disabilities.** Persons with disabilities may participate in the meeting through the methods set forth in paragraph 2. Individuals with disabilities requiring auxiliary aids or services in order to attend electronically should notify the Interim City Clerk, Garland Doyle at (248) 758-3200 or clerk@pontiac.mi.us at least 24 hours in advance of the meeting.

Dated 10-23-2020, 5:00 p.m.
Garland S. Doyle, Interim City Clerk
City of Pontiac
47450 Woodward Ave. Pontiac, MI 48342 Phone: (248) 758-3200

PONTIAC CITY COUNCIL

Kermit Williams, District 7
President
Randy Carter, District 4
President Pro Tem



Patrice Waterman, District 1
Megan Shramski, District 2
Mary Pietila, District 3
Gloria Miller, District 5
Dr. Doris Taylor Burks, District 6

It is this Council's mission "To serve the citizens of Pontiac by committing to help provide an enhanced quality of life for its residents, fostering the vision of a family-friendly community that is a great place to live, work and play."

Website: http://pontiac.mi.us/council/meeting_agendas_and_minutes/index.php

FORMAL MEETING

October 27, 2020

6:00 P.M.

196th Session of the 10th Council

Call to order

Invocation

Pledge of Allegiance

Roll Call

Authorization to Excuse Councilmembers

Amendments to and Approval of the Agenda

Approval of the Minutes

1. October 20, 2020

Closed Session

2. The City Attorney requests a closed session pursuant to MCL 15.268(h) to discuss information exempt from disclosure pursuant to MCL 15.243(1)(g), specifically an attorney-client privileged memorandum regarding to consider the purchase or lease of real property up to the time an option to purchase or lease that real property is obtained.

Special Presentations (Special Presentations are limited to 10 minutes.)

3. General Election Update
Presentation Presenter: Garland Doyle, Interim City Clerk
4. Update on Re-opening of Pontiac Youth Recreation and Enrichment Center (PYREC) post COVID-19
Guidelines: Schedule for Programming on-site and virtual
Presentation Presenters: Mayor Deirdre Waterman, Russell Harris, Boys and Girls Clubs of Southeastern Michigan (BGCSM), Robert Burch, PYREC and Tiffany Sula, BGCSM
5. IT City of Pontiac Telecommunication Strategy
Presentation Presenters: Frank Antoun, IT Department and Matthew Pickart, Insight Enterprises, Inc. (PCM)

Garland S. Doyle, M.P.A., Interim City Clerk

Office of the City Clerk 47450 Woodward Pontiac, Michigan 48342 Phone (248) 758-3200

Website: <http://pontiaccityclerk.com>

Recognition of Elected Officials

Agenda Address

Agenda Items

Ordinance

6. Adoption of an Ordinance to Amend the City of Pontiac General Employees' Retirement System and Provide a Date of Termination

Resolutions

Economic Development

7. Resolution to confirm Obsolete Property Rehabilitation Exemption Certificate for Kevadiya Properties, LLC at 100 N Saginaw, extending the time for completion of improvements for one year, and amending the beginning date to December 31, 2020.

Finance

8. Resolution to direct City Treasurer to distribute \$ 19,177.60 of drain assessments on the 2020 Winter Tax Rolls as directed by Water Resources Commissioner.
9. Resolution to direct City Treasurer to distribute \$44,780.60 of aged Miscellaneous Accounts receivable on the 2020 Winter Tax Rolls.
10. Resolution to approve a budget amendment to increase budgeted revenues in the amount of \$100,000 to the General Fund in account 101-000-532.000 –Grant Income, and appropriations in the amount of \$100,000 to a General Fund account. The City received a \$100,000.00 grant from the Community Foundation of Southeast Michigan to support the development of an internal grants management process and system

Planning and Economic Development

11. Approval to Amend the Development Agreement for Planet Fitness building mounted signs at the Village at Bloomfield and authorize the City Attorney to finalize the amendment for Mayor's signature.

Communication from the City Clerk

12. Medical Marihuana Monthly Application Review Process Update

Communication from the Mayor

13. City Attorney's Update on the Forensic Audit Contract

Mayoral Monthly Reports

14. Personnel Monthly Staff Report
15. Monthly Check Register (**The check registers for August 21 and 28, 2020; September 11 and 25, 2020 are attached. The check registers for September 4 and 18, 2020 has not been posted on the website.**)
16. City Credit Card Statement (**No report was received.**)

Public Comment

Mayor, Clerk and Council Closing Comments

Adjournment

#1

MINUTES

October 20, 2020 Study

**Official Proceedings
Pontiac City Council
194th Session of the Tenth Council**

Call to order

A Study Session of the City Council of Pontiac, Michigan was called to order electronically on Tuesday, October 20, 2020 at 6:10 p.m. by Council President Kermit Williams.

Roll Call

Members Present: Carter, Miller, Pietila, Shramski, Taylor-Burks, Waterman and Williams.

Mayer Waterman was present.

Clerk announced a quorum.

Amendments to the Agenda.

20-449 **Motion to move items 7 (An Ordinance to Amend the City of Pontiac General Employees' Retirement System and Provide a Date of Termination), 8(Resolution for Phoenix Center Mediation Date), 9 (Resolution to recognize first responders "our heroes" by City Council and the Mayor), 10 (Resolution to reduce the spread of COVID -19 by requesting that RFP's for both the replacement of the chairs in the Council Chambers along with cleaning the ventilation ducts in Council Chambers, be issued immediately. Additionally, this resolution request that the purchase orders for both the chairs in Council Chambers and the cleaning of the ventilation ducts be included and submitted to Oakland County in the CARES cost reimbursement for Pontiac and the replacement of the chairs and the cleaning of the ducts be completed before December 31, 2020), 12 (Resolution to approve the Budget Amendment for Finance Director), 13 (Resolution to ratify Mayoral appointment of Darrin Carrington as Finance Director), 14 (Resolution to approve the Inter-local Agreement for Cares between Oakland County and City of Pontiac) & 17 (Resolution to accept the Oakland County 2020-2021 ATPA Sub-Recipient Agreement with the City of Pontiac and authorizes the Mayor to sign document as presented) above item 5 (The City Attorney requests a closed session pursuant to MCL 15.268(h) to discuss information exempt from disclosure pursuant to MCL 15.243(1)(g), specifically an attorney-client privileged memorandum regarding to consider the purchase or lease of real property up to the time an option to purchase or lease that real property is obtained). Moved by Councilperson Waterman and second by Councilperson Pietila.**

Ayes: Miller, Pietila, Shramski, Taylor-Burks, Waterman, Williams & Carter

No: None

Motion Carried

Motion to postpone other items for one week. Moved by Councilperson Waterman and second by Councilperson Taylor-Burks. Motion withdrawn by Waterman and second withdrawn by Taylor-Burks.

October 20, 2020 Study

20-450 **Motion to postpone other items except for items 5 & 6 for one week.** Moved by Councilperson Waterman and second by Councilperson Taylor-Burks.

Ayes: Shramski, Taylor-Burks, Waterman, Williams, Carter, Miller & Pietila
No: None
Motion Carried

Approval of the Agenda

20-451 **Motion to approve the amended agenda.** Moved by Councilperson Waterman and second by Councilperson Taylor-Burks.

Ayes: Taylor-Burks, Waterman, Williams, Carter, Miller, Pietila & Shramski
No: None
Motion Carried

Approval of the Minutes

20-452 **Approval of minutes for September 29, 2020.** Moved by Councilperson Pietila and second by Councilperson Waterman.

Ayes: Waterman, Williams, Carter, Miller, Pietila, Shramski & Taylor-Burks
No: None
Motion Carried.

20-453 **Approval of minutes for October 6, 2020.** Moved by Councilperson Pietila and second by Councilperson Taylor-Burks.

Ayes: Williams, Carter, Miller, Pietila, Shramski, Taylor-Burks & Waterman
No: None
Motion Carried

20-454 **Approval of minutes for October 13, 2020.** Moved by Councilperson Pietila and second by Councilperson Taylor-Burks.

Ayes: Carter, Miller, Pietila, Shramski, Taylor-Burks, Waterman & Williams
No: None
Motion Carried

Subcommittee Report

Public Safety – September 2020

20-455 **Motion to suspend the rules to vote.** Moved by Councilperson Taylor-Burks and second by Councilperson Shramski.

Ayes: Miller, Pietila, Shramski, Taylor-Burks, Waterman, Williams & Carter

October 20, 2020 Study

No: None
Motion Carried

**Resolution
City Council**

20-456 **Resolution to recognize first responders “our heroes” by City Council and the Mayor.** Moved by Councilperson Pietila and second by Councilperson Carter.

WHEREAS, it is the sense of this body to pay proper tribute to individuals of great character and whose lives exemplify the highest ideals of humanity; and,
WHEREAS, on September 28, 2020, Oakland County Deputies and Waterford Regional Fire Station 6, were dispatched to the 100 block of Parkdale Avenue in the City of Pontiac for a 10-month-old infant who was unconscious and not breathing; and,
WHEREAS, Lieutenant James Todd, and Waterford Regional Firefighter Paramedics Kenneth Estell and CJ Waldron arrived at the scene and within a split-second, determined that time was of the essence and there was no time to wait for EMS, so they loaded the child into the backseat of a patrol car and continued performing CPR while Deputy John Dean drove the patrol car to McLaren Oakland Hospital; and,
WHEREAS, Deputies Samuel James, Colin Cavanaugh, Brandon Nolin, Ahmed Alzayadi and Brian Blackburn also took immediate action by assisting with traffic and clearing a path for the patrol car to arrive at the hospital expediently and safely; and,
WHEREAS, as a consequence of the life-saving measures, quick thinking, proficiency, training and collaboration between Oakland County Deputies and the Waterford Regional Firefighters, the infant was resuscitated; and,
WHEREAS, these First Responders are truly heroes in every sense of the word as they are motivated by selflessness, moral and physical courage as they risked their own lives to save the life of another in the midst of a global crisis, the COVID-19 pandemic.
NOW, THEREFORE BE IT RESOLVED, that the Mayor of the City of Pontiac and the members of the Pontiac City Council on behalf of the citizens of Pontiac, recognize and salute our First Responders for their contributions of leadership, self-sacrifice, and heroism to the community.

Ayes: Pietila, Shramski, Taylor-Burks, Waterman, Williams, Carter & Miller
No: None
Resolution Passed

20-457 **Motion to suspend the rules to vote.** Moved by Councilperson Pietila and second by Councilperson Taylor-Burks.

Ayes: Shramski, Taylor-Burks, Waterman, Williams, Carter, Miller & Pietila
No: None
Motion Carried

Ordinance

20-458 **An Ordinance to Amend the City of Pontiac General Employees' Retirement System and Provide a Date of Termination (First Reading).** Moved by Councilperson Waterman and second by Councilperson Taylor-Burks.

Ayes: Taylor-Burks, Waterman, Williams, Carter, Miller, Pietila & Shramski

No: None

Motion Carried

20-459 **Motion to suspend the rules to vote on items 10 & 14.** Moved by Councilperson Taylor-Burks and second by Councilperson Pietila.

Ayes: Carter, Miller, Pietila, Shramski, Taylor-Burks, Waterman & Williams

No: None

Motion Carried

Resolution

City Council

20-460 **Resolution to reduce the spread of COVID -19 by requesting that RFP's for both the replacement of the chairs in the Council Chambers along with cleaning the ventilation ducts in Council Chambers, be issued immediately. Additionally, this resolution request that the purchase orders for both the chairs in Council Chambers and the cleaning of the ventilation ducts be included and submitted to Oakland County in the CARES cost reimbursement for Pontiac and the replacement of the chairs and the cleaning of the ducts be completed before December 31, 2020.** Moved by Councilperson Taylor-Burks and second by Councilperson Shramski.

WHEREAS, on April 14, 2020, the Pontiac City Council in an attempt to reduce the spread of the COVID-19, passed a resolution authorizing the Mayor to contract with Restoration 1 in an amount not to exceed \$15,000.00 for the cleaning, sanitizing and disinfecting of City Hall, 50th District Court, Ruth Peterson Senior Center and Bowens Senior Center.

WHEREAS, to date, the deep cleaning, sanitizing and disinfecting of City Hall, 50th District Court, Ruth Peterson Senior Center and Bowens Senior Centers have not been cleaned; and

WHEREAS, during budget discussions and amidst the peak of the COVID-19 pandemic, the City Council and the Executive discussed and agreed to remove the fabric seats in Council Chambers and replace them with vinyl seats; thereby, allowing for proper routine cleaning and disinfecting; and

WHEREAS, to date, the seats have not been removed or replaced; and

WHEREAS, during budget discussions, there was further discussion regarding issuing RFP's for ventilation cleaning of the Council Chambers; and,

WHEREAS, due to COVID-19, the Michigan Legislature passed legislation allowing for public bodies to meet virtually until December 31, 2020; and,

WHEREAS, COVID-19 more specifically CDC social distancing guidelines, mandate that Council Chambers be limited to 14 people; and,

WHEREAS, due to the increased costs incurred by the City due to COVID-19, the City of Pontiac upon signing the Interlocal Agreement with Oakland County, is entitled to CARES reimbursable expenses of up

to One Million, Five Hundred and Thirty-Three Thousand, One Hundred and Eighty-Seven (\$1,533,187.50) Dollars and Fifty Cent; and,

WHEREAS, both the replacement of the vinyl chairs and the cleaning of the ventilation ducts in Council Chambers are reimbursable expenses as verified by the Office of the Oakland County Executive; and,

WHEREAS, the City of Pontiac can make several submissions to Oakland County for reimbursement until the deadline of November 30, 2020.

NOW THEREFORE BE IT RESOLVED, the Pontiac City Council is requesting that RFP's for both the replacement of the chairs in the Council Chambers along with cleaning the ventilation ducts in Council Chambers, be issued immediately.

BE IT FURTHER RESOLVED that the purchase orders for both the chairs in Council Chambers and the cleaning of the ventilation ducts be included and submitted to Oakland County in the CARES cost reimbursement for Pontiac and the replacement of the chairs and the cleaning of the ducts be completed before December 31, 2020.

Ayes: Miller, Pietila, Shramski, Taylor-Burks, Waterman, Williams & Carter

No: None

Resolution Passed

Finance

20-461 **Resolution to approve the Inter-local Agreement for Cares between Oakland County and City of Pontiac.** Moved by Councilperson Waterman and second by Councilperson Taylor-Burks.

WHEREAS, the City of Pontiac and Oakland County have entered into an agreement pursuant to the Urban Cooperation Act of 1967, 1967 Public Act 7, MCL 124.501 *et seq.*, for the purpose of County distributing a portion of its CARES Act funds to the City. County has allocated a portion of its CARES Act funds to be distributed to CVTs within Oakland County, which will be used to assist CVTs in meeting certain areas of need caused by the COVID-19 pandemic.

NOW THEREFORE BE IT RESOLVED, the City Council of the City of Pontiac approves the agreement for Cares Act Distribution between Oakland County and City of Pontiac and authorizes the Mayor to sign the agreement on behalf of the city.

Ayes: Pietila, Shramski, Taylor-Burks, Waterman, Williams, Carter & Miller

No: None

Resolution Passed

Point of Privilege to allow Former State Rep Tim Griemel to speak. Moved by Councilperson Taylor-Burks and second by Councilperson Pietila.

20-462 **Motion to suspend the rules to vote.** Moved by Councilperson Waterman and second by Councilperson Taylor-Burks.

Ayes: Taylor-Burks, Waterman, Williams, Carter, Pietila & Shramski

No: Miller

Motion Carried

Resolution

Finance

20-463 **Resolution to approve the Budget Amendment for Finance Director.** Moved by Councilperson Taylor-Burks and second by Councilperson Waterman.

WHEREAS, the City of Pontiac timely approved the FY 2020-2021 budget on June 29, 2020; and WHEREAS, the adopted FY 2020-2021 General Fund budget includes appropriations in the Finance Department for salaries for personnel using account number 101-206-702.000; and an appropriation for other professional services using account number 101-206-818.000.

WHEREAS, the appropriation for account number 101-206-702.000 is \$311,250 and the appropriation for account number 101-206-818.000 is \$140,000; and

WHEREAS, section 5.106 of the Charter states “after adoption of the appropriations ordinance, and upon at least one week’s notice in a newspaper of general circulation in the City, the Council by a resolution of five members, may amend such ordinance to authorize the transfer of an unused balance appropriated for one purpose to another purpose, or to appropriate available revenues not previously appropriated.”; and

WHEREAS, the proposed appropriation increase is \$81,000 for account number 101-206-702.000 to \$392,250; and the proposed appropriation decrease is \$81,000 for account number 101-206-818.000 to \$59,000; and

WHEREAS, the proposed appropriation transfer will be used to increase the Finance Director Salary from \$50,000 to \$131,000.

NOW THEREFORE, BE IT RESOLVED that the City Council authorizes the City Clerk to publish the notice of the budget amendment in the Oakland Press.

Ayes: Waterman, Williams, Carter, Pietila, Shramski & Taylor-Burks

No: Miller

Resolution Passed

20-464 **Motion to suspend the rules to vote.** Moved by Councilperson Waterman and second by Councilperson Taylor-Burks.

Ayes: Waterman, Williams, Carter, Miller, Pietila, Shramski & Taylor-Burks

No: None

Motion Carried

City Council

20-465 **Resolution for Phoenix Center Mediation Date.** Moved by Councilperson Waterman and second by Councilperson Taylor-Burks.

WHEREAS, the Emergency Manager seeking to cut costs, sought to demolish the Phoenix Center which triggered a lawsuit with Ottawa Towers; and,

WHEREAS, the city’s Legal Department, after several unsuccessful appeals, advised the Pontiac City Council to enter into a settlement agreement with Ottawa Towers; and,

WHEREAS, the City of Pontiac entered into a settlement agreement with Ottawa Tower II, LLC and the North Bay Drywall, Inc. Profit Sharing Plan & Trust on November 1, 2018; and,

WHEREAS, the parties participated in mediation and agreed upon the material terms of the settlement of their disputes; and,

WHEREAS, in consideration of the immediate discharge of all liens and encumbrances on the Phoenix Center, the City was required to pay Three Million Five Hundred Thousand (\$3,500,000.00) Dollars upon execution of all settlement documents in addition to Three Hundred and Fifty Thousand (\$350,000.00) Dollars in full and final reimbursement for all attorney fees and costs; and,

WHEREAS, the section entitled Maintenance, Repair and Improvements to the Phoenix Center and Tunnel, more specifically, section 6.2 of the settlement agreement, requires that in addition to the payments set forth in the Agreement, the City shall pay up to Six Million (\$6,000,000.00) Dollars over a ten (10) year period beginning as of the Effective Date of the Agreement for the maintenance and capital repair of and improvements to the Phoenix Center necessary to bring and maintain the Phoenix Center into conformance with the requirements of the International Property Maintenance Code (2015 edition), as referenced in the Michigan Building Code and the Michigan Rehabilitation Code (2015 edition).

WHEREAS, on April 28, 2020, the Pontiac City Council in an effort to comply with the Settlement Agreement as well as being good stewards and overseers of the funds of the City; passed a resolution for a budget amendment requiring that Seven Million (\$7,000,000.00.) Dollars be taken from the general fund (101) and allocated to the Phoenix Center (585-564-974.035) for parking structure repairs. Subsequently, the Council further provided that these funds be secured in the 2020-2021 fiscal year's budget.

WHEREAS, to date, there have been no repairs made to the Phoenix Center and the Executive has indicated to the Council that the City will be going back to mediation.

NOW THEREFORE BE IT RESOLVED, that the Pontiac City Council on behalf of the Citizens of Pontiac, request that the mediation date, time and location be provided to the Pontiac City Council during the Council meeting on Tuesday, October 13, 2020.

BE IT FURTHER RESOLVED, the Council further requests, that the date, time and location of any and all legal proceedings relating to the Phoenix Center be provided to the Council in writing, at least two weeks (14 days) prior to the actual date of the proceeding.

Ayes: Williams, Carter, Miller, Pietila, Shramski, Taylor-Burks & Waterman

No: None

Resolution Passed

20-466 **Motion to suspend the rules to vote.** Moved by Councilperson Waterman and second by Councilperson Taylor-Burks.

Ayes: Williams, Carter, Pietila, Shramski, Taylor-Burks & Waterman

No: Miller

Motion Carried

Resolution

Finance

20-467 **Resolution to ratify Mayoral appointment of Darrin Carrington as Finance Director.** Moved by Councilperson Pietila and second by Councilperson Waterman.

WHEREAS, pursuant to City Charter Section 4.106, the Mayor has the authority to appoint directors of each department of the executive branch; and
WHEREAS, the Director of Finance position is not currently filled; and
WHEREAS, on September 15, 2020, the Mayor introduced Director of Finance appointment Mr. Darin Carrington; and
WHEREAS, Mr. Carrington is imminently qualified to fulfill that position;
NOW THEREFORE, BE IT RESOLVED the City Council hereby approves of the appointment of Mr. Darin Carrington as the City of Pontiac Finance Director and resets the position to an annual salary of \$131,040.

Ayes: Pietila, Shramski, Taylor-Burks & Waterman
No: Carter, Miller & Williams
Resolution Passed

20-468 **Motion to suspend the rules to vote.** Moved by Councilperson Pietila and second by Councilperson Waterman.

Ayes: Pietila, Shramski, Taylor-Burks, Waterman & Williams
No: Miller & Carter
Motion Carried

20-469 **Resolution to accept the Oakland County 2020-2021 ATPA Sub-Recipient Agreement with the City of Pontiac and authorizes the Mayor to sign document as presented.** Moved by Councilperson Pietila and second by Councilperson Waterman.

WHEREAS, the City of Pontiac has been utilizing the Auto Theft Prevention Authority Grant through Oakland County since 2013; and
WHEREAS, the previous agreement with the Oakland County Sheriff's Office expired September 30, 2020; and
WHEREAS, the County and City may enter into a sub-recipient agreement by which the Oakland County Sheriff's Office would continue to assign a full-time Sheriff Deputy to the ATPA activities; and
WHEREAS, the Oakland County Sheriff's Office agrees to provide reimbursement to the City of Pontiac under the terms and conditions of the agreement up to 50 percent of the eligible expenditures;
NOW THEREFORE, BE IT RESOLVED that the City Council, upon the recommendation, of the Administration accepts the Oakland County 2020-2021 ATPA Sub-Recipient Agreement with the City of Pontiac and authorizes the Mayor to sign the document as presented.

Ayes: Pietila, Shramski, Taylor-Burks, Waterman & Williams
No: Carter & Miller
Resolution Passed

20-470 **Resolution to go into closed session.** Moved by Councilperson Waterman & second by Councilperson Taylor-Burks.

WHEREAS, Michigan Open Meetings Act Section B(h), MCL 15.268(h), allows a public body to go into closed session to consider material exempt from discussion or disclosure by state or federal statute; and WHEREAS, Michigan Freedom of Information Act Section 13(g) exempts from disclosure records subject to the attorney-client privilege;

NOW THEREFORE, BE IT RESOLVED by the Pontiac City Council that it recess into closed session to discuss an attorney-client privileged memorandum to consider the purchase or lease of real property that is exempt from disclosure by statute, specifically an attorney client privileged memorandum exempt from disclosure pursuant to MCL 15.243(1)(g).

Ayes: Shramski, Taylor-Burks, Waterman, Williams, Carter, Miller & Pietila

No: None

Resolution Passed

20-471 **Motion to come out of closed session.** Moved by Councilperson Pietila and second by Councilperson Taylor-Burks.

Ayes: Taylor-Burks, Waterman, Williams Carter, Pietila & Shramski

No: None

Motion Carried

20-472 **Motion to suspend the rules to vote.** Moved by Councilperson Shramski and second by Councilperson Pietila.

Ayes: Waterman, Williams, Carter, Pietila, Shramski & Taylor-Burks

No: None

Motion Carried

20-473 **Resolution to schedule a special meeting for Friday, October 23, 2020 at 7pm for a closed session related to Phoenix Center.** Moved by Councilperson Pietila and second by Councilperson Taylor-Burks.

Ayes: Williams, Carter, Pietila, Shramski, Taylor-Burks & Waterman

No: None

Resolution Passed

Public Comment

Five (5) individuals submitted public comments read by the City Clerk.

Adjournment

Council President Kermit Williams adjourned the meeting at 9:01 p.m.

GARLAND S DOYLE
INTERIM CITY CLERK

#2

**CLOSED
SESSION**

Pontiac City Council Resolution



Whereas, Michigan Open Meetings Act Section B(h), MCL 15.268(h), allows a public body to go into closed session to consider material exempt from discussion or disclosure by state or federal statute; and

Whereas, Michigan Freedom of information Act Section 13(g) exempts from disclosure records subject to the attorney-client privilege;

Now, Therefore, Be It Resolved by the Pontiac City Council that it recess into closed session to discuss an attorney-client privileged memorandum to consider the purchase or lease of real property that is exempt from disclosure by statute, specifically an attorney client privileged memorandum exempt from disclosure pursuant to MCL 15.243(1) (g).

#3

**SPECIAL
PRESENTATION**



**WORKING TO ENSURE EVERYONE CAN
VOTE IN 2020**

**Absentee Ballots Are Now Available
in the City Clerk's Office
Monday - Friday
8:30a.m. – 8:00p.m**

**Absentee Voting ends at 4:00 p.m. on November 2nd
Garland Doyle
Interim City Clerk**

EXTENDED HOURS

The Clerk's Office has been open an additional 85.5 hours (extended & weekend hours) to serve the public.

- **Weekday Hours**

- **Monday – Friday 8:30a.m. – 8:00p.m.**

- **Weekend Hours**

- **Saturday, October 31st 9:00a.m. – 4:00p.m.**

- **Sunday, November 1st 9:00a.m. – 4:00p.m.**

ATTENTION: VOTERS

SEVEN THINGS TO DO AFTER YOU RECEIVE YOUR BALLOT

- 1) Check the label located on the bottom right of the envelope for the correct name and check to see if your ballot number matches the number on the actual ballot.
- 2) Please read the instructions inside of the ballot envelope prior to voting.
- 3) The ballot is two sided.
- 4) If you make a mistake, please contact the Clerk's Office at (248) 758-3200 for information on how to spoil your ballot so you can be issued another one.
- 5) Remember to sign, date and seal your envelope.
- 6) Your signature needs to match your signature on your Drivers' License or State Identification Card.
- 7) You can return your ballot directly to the dropbox by the elevator on the 1st floor of City Hall or to 1 of the 4 official drive-up dropboxes. No postage necessary if you return your ballot to an official dropbox location.

HOW TO VOTE THE PARTISAN SECTION (POLITICAL PARTIES) OF YOUR BALLOT?

Voter Options

- 1) Straight Ticket: Vote the party of your choice. Nothing further need be done in the partisan section.
- 2) Mixed Ticket: When you want to vote for candidates of different parties. Vote for the individual candidates of your choice in each office.

INSIDE CITY HALL DROP BOX





Office of the City Clerk

7 Drive Up Ballot Drop Boxes

Locations

- Bowens Center 52 Bagley 48341 – District 1
- City Hall 47450 Woodward 48342 – District 7
- Fire Station 787 W Huron 48341 – District 2
- Herrington Elementary 541 Bay 48342 – District 5
- Kennedy/Owen School 1700 Baldwin 48340 – District 4
- Ruth Peterson Center 990 Joslyn – District 6
- Walt Whitman Elementary 125 W Montcalm 48342 – District 3

Hours

- 24 Hours Daily
- 24 Hours Daily
- 24 Hours Daily
- Mon. – Fri. 6:00a.m. – 6:00p.m.
- 24 Hours Daily
- 24 Hours Daily
- 24 Hours Daily
- 24 Hours Daily

• Voters can drop their ballots in any of the drop boxes.



THINGS TO KNOW

After you return your absentee ballot to one of our official ballot dropboxes or by mail.

You can check on the status of your absentee ballot by visiting www.michigan.gov/vote

Website: <http://pontiaccityclerk.com>



Pontiac City Clerk



PontiacClerk



Pontiac City Clerk



Pontiac City Clerk

#4

**SPECIAL
PRESENTATION**



BOYS & GIRLS CLUBS
OF SOUTHEASTERN MICHIGAN

Presented by

Mayor Deirdre Waterman, Russell Harris (BGCSM Executive Area Director,)

Robert Burch (PYREC Assistant Manager) &

Tiffany Sula (BGCSM Program Director)

Pontiac Youth Recreation & Enrichment Center (PYREC)





Pontiac Youth Recreation & Enrichment Center

BGCSM will support and bolster programming provided by PYREC to increase youth engagement

BGCSM will create an infrastructure through strategic partnerships that will increase economic mobility for youth from Pontiac.

PYREC millage provides secured funding through 2026

Community leaders and organizations support the partnership – Guidepost Letters of Support

Currently serves over **2,500 youth** in the city of Pontiac

70% Millage vote passed which secures funding through 2026

Currently partners with organizations offering youth access to **signature programs** in STEAM and arts.

BGCSM and PYREC Partnership Overview

PYREC will serve as the location for youth and adult activities (ages 6-20) powered by BGCSM

BGCSM will provide a world class youth engaging experience which leads to the realization of their full potential

PYREC powered by BGCSM will be the sole child care, afterschool service for Pontiac Residents

PYREC powered by BGCSM will aim to curb juvenile delinquency currently serving over 2500 youth in Pontiac



Safety/Covid-19 Precautions

- Temperature & safety/health checks to all staff, youth and guests upon entry to the building.
- Face masks worn at all times by staff, youth and guests.
- All program areas cleaned & sanitized hourly and logged.
- Permitting any sickness, staff or youth will not be able to return for 14 days without a negative test or note from a doctor.
- Emergency protocols posted in all program areas.
- Separate emergency/isolation room for sick youth awaiting pick-up.
- 10:1 staff VS. Youth ratio.
- 50 youth limited in the building at any given time.
- Limit of personal belongings in building.

PYREC Programs

- **Cranbrook Institute of Science:** Customized STEM hands-on STEM lessons and science experiments.
- **The Y (YMCA): Port Sports:** Positive Play Initiative mobile sports program provides free play and sports sampling.
- **Charity Music:** Sound Booth Instrument Sampling. Kids explore wind, percussion, string and electronic instruments.
- **Girl Scouts:** Leadership development and enrichment programs for girls.
- **Sheriff PAL Soccer for Success:** Soccer for Success after school soccer program teaches youth soccer skills while learning about eating right and other ways to stay healthy. Youth gain important decision-making and relationship skills through positive interactions with a coach-mentor and peers.

Boys & Girls Clubs of Southeastern Michigan Programs

- **Smart Girls:** A small-group health, fitness, prevention/education and self-esteem enhancement program designed to meet the developmental needs of girls in three age groups
- **Passport to Manhood:** Promotes and teaches responsibility in boys ages 8-17 with specific aspects of manhood through highly interactive activities with targeted efforts to engage young men in discussions & activities that reinforce positive behavior.
- **Torch & Keystone Clubs:** Chartered small-group leadership and service clubs for boys and girls ages 10-18.
- **Youth for Unity:** Provides youth with the groundwork that will help them better understand diversity and combat prejudice, bigotry and discrimination.
- **Book Nook:** Literacy program through Brilliant Detroit pairing youth virtually with a tutor for all literacy needs.
- **Power Hour:** Helps Club members ages 6-18 achieve academic success by providing homework support, tutoring and technology engaged activities.
- **Triple Play:** Health and wellness initiative, strives to improve the overall health of members, ages 6-18, by increasing their daily physical activity, teaching them good nutrition and helping them develop healthy relationships.
- **Sports/Fitness:** Youth sports leagues and fitness groups.
- **Social Recreation:** Emphasis on social and emotional development, or the social, cognitive, and behavioral skills that youth need to be healthy and productive.
- **Ponyride University:** Focuses on financial and entrepreneurship opportunities for youth through program such as Junior Achievement and Money Matters.
- **Industry Club:** Fashion and design focused allowing members explore their creative side.
- **Healthy Habits:** Designed to incorporate healthy living and active learning in every part of the Club Experience, emphasizes good nutrition, regular physical activity and improving overall well-being.
- **The Arts:** Comprised of visual, digital, performing and applied arts.
- **Docuseries:** New program focusing on older youth viewing documentaries that pertain to their lives or the world and holding discussions.



Overview Schedule for the day at PYREC

- Breakfast and Lunch provided to all youth.
- AM Programming (7:30am-2pm)
 - Focused around educational enrichment/schoolwork.
 - Learning Pods -5 classrooms with up to 10 youth and 1 Academic Support Specialist.
- PM Programming (2pm-6pm)
 - Homework Help
 - Traditional recreational programming
 - Virtual Programming
 - Program partners



City of Pontiac Youth Sports

City Wide Youth Sports Leagues

- Basketball
- Flag Football
- Tackle Football
- T-Ball & Baseball
- Soccer
- Pee-Wee Sports

Sports Camps & Clinics

Upcoming PYREC Events/Important Dates

- Tentative re-opening date of Monday, October 19, 2020
- Harvest Activities for PYREC youth on Thursday, October 29, 2020 from 3pm-6pm
- PSD district wide ½ day of school- Friday, October 30, 2020
- PSD No School for students due to Election Day- Tuesday, November 3, 2020
- PSD ½ day of school for secondary students- Tuesday, November 17, 2020
- PSD ½ day of school for elementary students- Wednesday, November 18, 2020
- PSD ½ day of school for all students- Wednesday, November 25, 2020
- PSD Thanksgiving Break, No School- Thursday, November 26 & Friday, November 27, 2020
- PSD district wide ½ day of school- Friday, December 18, 2020
- PSD Christmas Holiday Break, No school- Monday, December 21-Friday, January 1, 2020



BOYS & GIRLS CLUBS
OF SOUTHEASTERN MICHIGAN

#5

**SPECIAL
PRESENTATION**

Agenda – City of Pontiac Telecommunication Strategy

- Review Current Telecommunications System
- Review New Telecommunication Strategy
- Review New Estimated Costs
- Next Steps

Telecommunications > Today

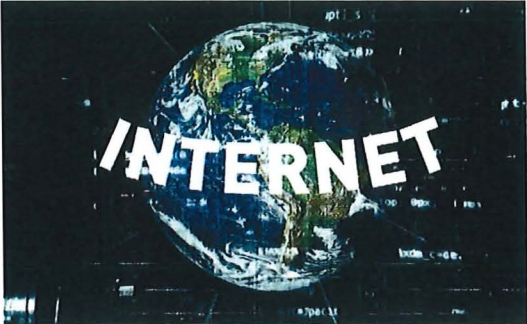

This Photo by Unknown Author is licensed under [CC BY](#)

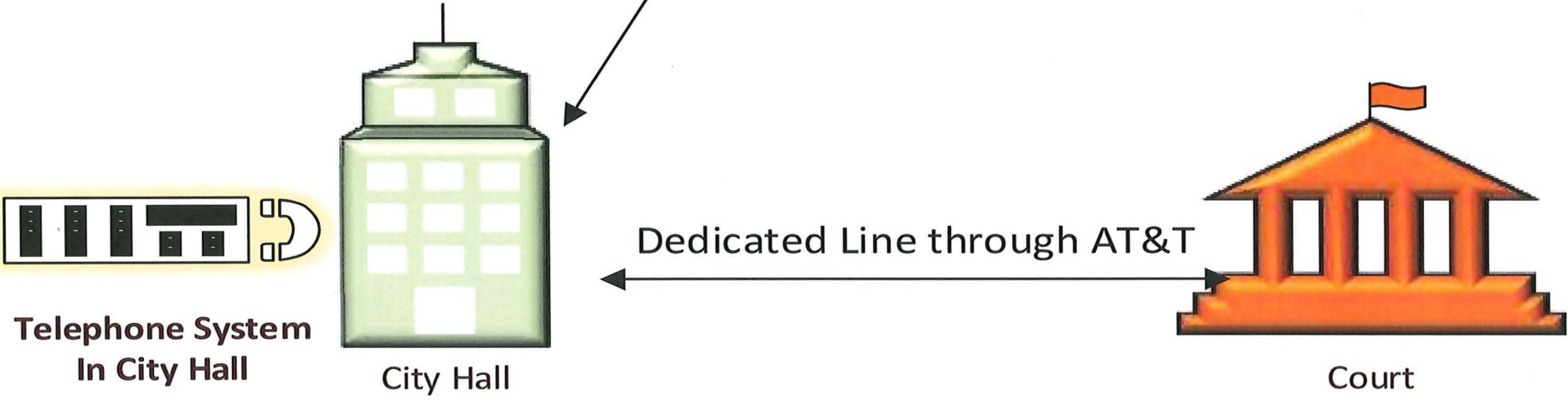

Current ShoreTel IP PBX (phone system)

- The Phone system the City is using as of now is nearly 10 Years old.
- The system was the state of the art 10 years ago.
- New technologies have emerged.
- Communications have improved and become less costly with added features.

Current Telecom System Components

- Dated ShoreTel IP PBX and AT&T Voice SIP trunk are used for processing phone calls. It's capable of handling 46 concurrent calls.
- We currently have approximately 106 ShoreTel IP phones.
- ShoreTel system is at capacity today.
- 16 Fax lines used for faxes, these fax lines serve Court and the City Hall.
- 100Mbps AT&T Internet connection at City Hall.
- 50Mbps AT&T connection between City Hall and District Court.

The Cloud

- The Cloud is consumption based (usage) for technology resources from Companies like Microsoft, Google, Amazon and many others.
- Hardware is provided and maintained by the Cloud providers instead of locally at the customer location.
- Many organizations are migrating to Cloud Services.
- UCaaS is a cloud based unified communications as a service solution that will save the City money and add many new features.
- We have contacted several companies, and thoroughly evaluated these new emerging technologies.



[This Photo](#) by Unknown Author is licensed under [CC BY-SA](#)

New Cloud Communication System

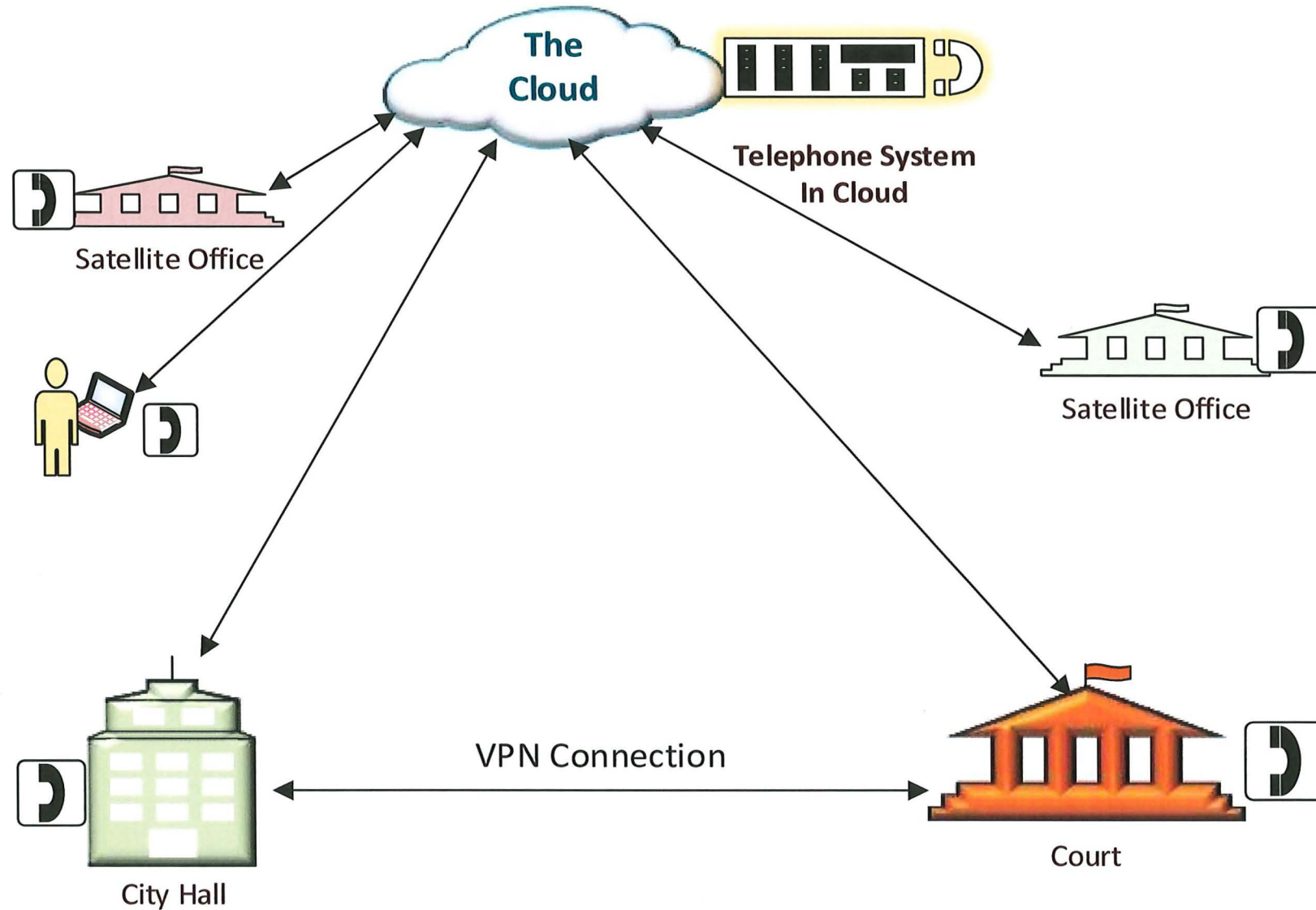

Ring Central – Market Leader in Cloud Communications

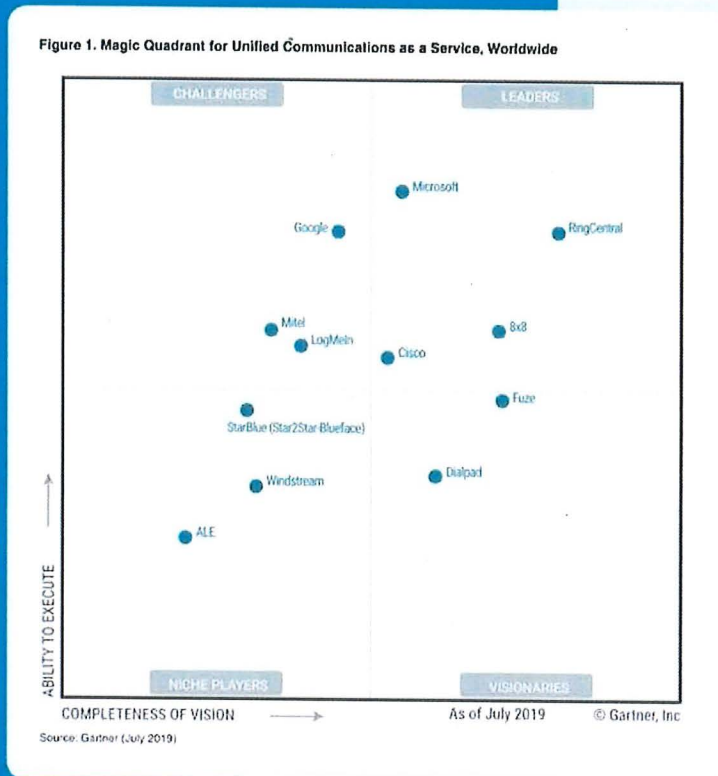

GARTNER

A Leader in the 2019 Gartner Magic Quadrant for **Unified Communications as a Service, Worldwide leadership**

This graphic was published by Gartner, Inc. as part of a larger research document and should be evaluated in the context of the entire document. The Gartner document is available upon request from RingCentral. Gartner does not endorse any vendor, product or service depicted in its research publications, and does not advise technology users to select only those vendors with the highest ratings or other designation. Gartner research publications consist of the opinions of Gartner's research organization and should not be construed as statements of fact. Gartner disclaims all warranties, express or implied, with respect to this research, including any warranties of merchantability or fitness for a particular purpose. Gartner, Magic Quadrant for Unified Communications as a Service, Worldwide, Daniel O'Connell, Megan Fernandez, Rafael Benitez, Christopher Trueman, Sebastian Hernandez, 30 July 2019.

RingCentral

Evaluation Process

- Key Criteria

- ✓ On-Premise or Cloud based
- ✓ Cost Effective
- ✓ Telecommunication Costs
- ✓ Easily scalable to allow for City demands
- ✓ Ease of Management & Administration (lower cost of management)
- ✓ Supports mobility and integration with future solution (Microsoft 365)
- ✓ Availability and Redundancy
- ✓ Security
- ✓ Reporting & Audit

Evaluation Process

- Market Solutions Evaluated
 - On Premise
 - Cisco UC – Upper left on magic quadrant, market share leader for on-premise
 - Cloud (UCaaS)
 - 8 x 8 – Gartner Magic Quadrant, upper right quadrant
 - RingCentral - Gartner Magic Quadrant, *leader* in upper right quadrant
 - Evaluated all 3 solutions based off key criteria
 - RingCentral was the best solution for City
 - RingCentral is a partner with AT&T

Pure cloud advantages

On-premises/managed communications services

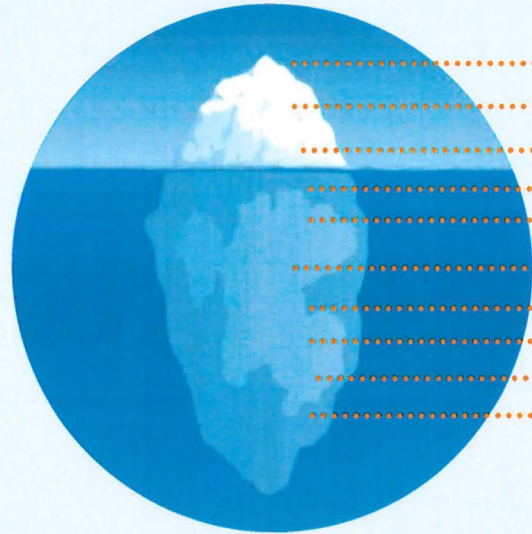

- PBX hardware & software
- Upgrades
- Web meetings
- Audio conferencing
- Fax
- Telco (PRIs, T1s)
- Local, long distance, toll free
- Multi-location (MPLS, PSTN)
- PBX parts
- Outside services

Pure Cloud UCaaS



All-inclusive user pricing,
Uniform user experience

- Innovation
- Agility
- Speed
- Flexibility
- Efficiency

RingCentral solution

- Single “pane of glass” for all communication streams
- Intuitive User & Management Interface
- Open & Integrated Platform
- Industry Leading Reliability – 99.999% uptime SLA
- World-Class Professional Services & Customer Support

CITY OF
Pontiac
MICHIGAN

CALL

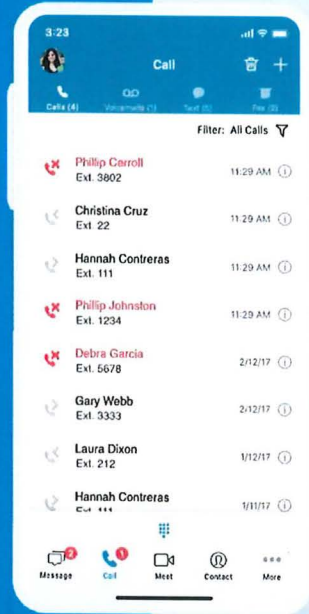
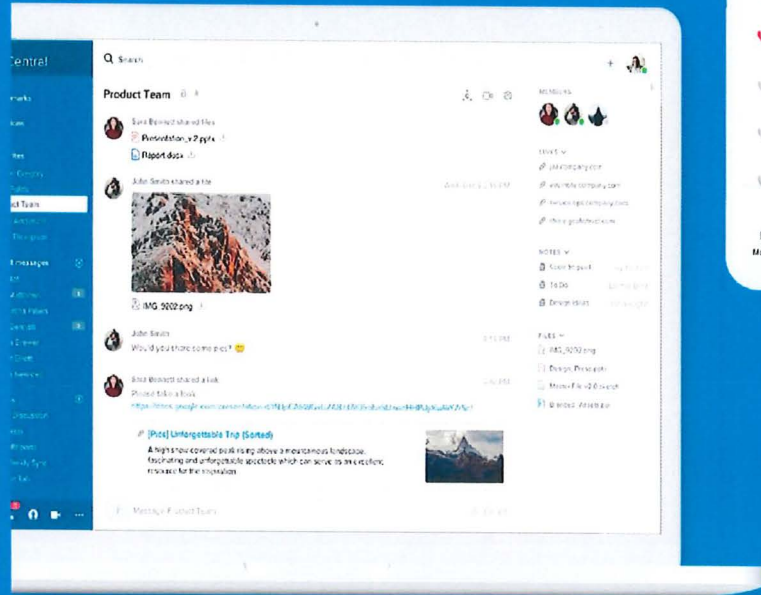

“Hello” never sounded this good.

Enterprise-grade cloud PBX

Mobile and desktop apps

Toll free, vanity, and local numbers

Extensions

Smart routing

IVR self-service

QoS Analytics

Global, secure, reliable

New Telecommunication System Components

- ✓ City Hall will have its own Internet connection of 100Mbps
- ✓ District Court will have its own internet connection of 100Mbps
- ✓ On-Board RingCentral UCaaS Cloud provider for collaboration IP phone system will cost approximately \$26,000/year for services only. New phones and implementation are additional one-time costs.
- ✓ No annual maintenance fees.
- ✓ System is maintained by RingCentral, administered by City IT team.
- ✓ IT has budgeted \$125k for FY20/21 for new system.

New Solution – Estimated Costs

Description	Current Costs - Annually	Projected Annual Cost – UCaaS
AT&T/ShoreTel Costs	\$93,000	
AT&T Costs - New		\$30,000
Ring Central - New		\$26,000
Totals	\$93,000	\$56,000
Annual Estimated Savings		\$37,000

One Time Costs	Estimated Cost
New Phones & Implementation Costs	\$33,000
** IT has budgeted \$125,000 for FY20/FY21 for this project	

Telecommunication Strategy

✓ Next Steps

- ✓ Gain Approval from Executive Team
- ✓ Gain Approval from City Council

Thank you for meeting with us Today!



#6

ORDINANCE

Founded in 1852
by Sidney Davy Miller



MICHIGAN
ILLINOIS
NEW YORK
OHIO
WASHINGTON, D.C.
CANADA
CHINA
MEXICO
POLAND
QATAR

SAMANTHA A. KOPACZ
TEL (248) 267-3223
FAX (248) 879-2001
E-MAIL kopacz@millercanfield.com

Miller, Canfield, Paddock and Stone, P.L.C.
840 West Long Lake Road, Suite 150
Troy, Michigan 48098
TEL (248) 879-2000
FAX (248) 879-2001
www.millercanfield.com

October 1, 2020

Pontiac City Council
City Hall
47450 Woodward Avenue
Pontiac, Michigan 48342

Re: Proposed Ordinance to Amend the City of Pontiac General Employees' Retirement System and Establish a Date of Termination

Dear Honorable Council:

As you are aware, the City of Pontiac (the "City") entered into an innovative settlement agreement with a class of retirees ("CPREA") related to City funding of retiree health benefits in the United States District Court for the Eastern District of Michigan Case No. 2:12-cv-12830 (the "Settlement Agreement"). The terms of the Settlement Agreement generally dictate that, subject to approval by the Internal Revenue Service (the "IRS"), the City will terminate the General Employees' Retirement System (the "GERS"), establish a new defined benefit plan under Internal Revenue Code ("Code") §401(a) (which will assume all of the pension liabilities of the GERS plus have an initial "substantial cushion") (the "Reestablished GERS"), and establish a voluntary employees' beneficiary association under Code §501(c)(9) (the "VEBA"). In order to effectuate the Settlement Agreement, Miller Canfield made four submissions to the IRS on behalf of the City (collectively, the "IRS Submissions") on May 22, 2020. Copies of the IRS Submissions were previously made available to the Honorable Council.

Of relevance to the Honorable Council today is the IRS Submission related to the City of Pontiac General Employees' Retirement System Application for Determination for Terminating Plan (IRS Form 5310) ("GERS Termination Application"). The IRS has conducted an initial review of the GERS Termination Application and has indicated that it now needs the Honorable Council to formally establish a termination date for the GERS and adopt the proposed amendment. In this regard, the enclosed proposed ordinance ("Proposed Ordinance") establishes a termination date of March 31, 2021. In summary, the Proposed Ordinance:

- 92-11. Clarifies that employees hired pursuant to the MAPE collective bargaining agreement with the City are eligible to participate in the GERS.
- 92-46. Establishes the City's right to terminate the GERS.
- 92-46A. Establishes a March 31, 2021 termination date for the GERS and addresses how assets will be transferred.
- 92-48, 92-49, 92-50. Deletes provisions of the GERS that were adopted in 2014 but never implemented.

MILLER, CANFIELD, PADDOCK AND STONE, P.L.C.

Pontiac City Council

-2-

October 1, 2020

We understand that Deborah Munson, on behalf of the GERS Board, provided the Honorable Council with a draft GERS termination amendment on May 22, 2020. We believe that the Proposed Ordinance and the version provided by the GERS Board are substantively identical, except (1) the Proposed Ordinance includes a March 31, 2021 termination date to account for the IRS's request; and (2) the Proposed Ordinance includes a reference to a "collective bargaining agreement with the City" when addressing MAPE employee eligibility in Section 92-11. It is understood that the GERS Board met on September 30, 2020 and concurred with the proposed March 31, 2021 termination date.

In order to permit the IRS to rule on the GERS Termination Application and effectuate the Settlement Agreement, we recommend and respectfully request that the Honorable Council adopt the Proposed Ordinance. The IRS has requested that City Council take action in this regard as soon as possible.

Please note that if the IRS does not approve the GERS Termination Application prior to March 31, 2021, the Honorable Council can take action prior to that date to reverse the proposed termination. The IRS is already aware of the proposed termination date and will hopefully issue its ruling in advance of such date.

As a final note, the City of Pontiac Reestablished General Employees' Retirement System Application for Determination for Employee Benefit Plan (IRS Form 5300) ("Reestablished GERS Application") is also currently under review by the IRS. Once the IRS approves the Reestablished GERS Application, the Honorable Council will need to take action to adopt that plan effective April 1, 2021.

Please contact me with any questions.

Very truly yours,

Miller, Canfield, Paddock and Stone, P.L.C.

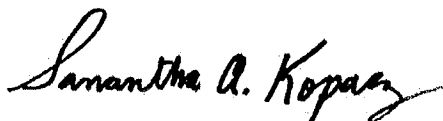

By: _____
Samantha A. Kopacz

SAK/reu

Enclosure

cc: Dr. Deirdre Waterman, Mayor of City of Pontiac
John Clark, Esq.

36640516.1\071371-00075

Ordinance No. XXXX

AN ORDINANCE TO AMEND THE CITY OF PONTIAC GENERAL EMPLOYEES' RETIREMENT SYSTEM AND PROVIDE A DATE OF TERMINATION.

The City of Pontiac ordains:

Section 1. Amendments.

That the City of Pontiac General Employees' Retirement System ("GERS") is hereby amended as follows:

- a. Section 10(g) [92-11(g)] of the GERS is amended in its entirety to read as follows:

(g) No person hired after April 1, 2013, shall be eligible to participate in the General Employees' Retirement System, except for employees hired pursuant to, and whose employment is covered by, the Michigan Association of Public Employees (MAPE) collective bargaining agreement with the City.

- b. Section 36 [92-46] of the GERS is amended in its entirety to read as follows:

Any and all provisions of this General Employees' Retirement System may, from time to time, be modified, changed, or terminated by Ordinance duly adopted by the City Council of the City of Pontiac. The Council shall consult with the Board and seek its technical review of the proposed changes prior to amendment or termination of the Ordinance. The accrued financial benefits of this General Employees' Retirement System shall not be diminished or impaired by such modifications or changes and subject to the conditions of Public Act 728 of 2002, as amended. All provisions of City law inconsistent with the provisions of this General Employees' Retirement System are hereby repealed to the extent of such inconsistency.

- c. Section 36A [92-46A] of the GERS is added in its entirety to read as follows:

The General Employees' Retirement System is hereby terminated effective March 31, 2021 ("Termination Date"). Effective with this termination, all assets of the General Employees' Retirement System shall be allocated in accordance with the provisions of this Section, and the accrued benefit of each affected Member shall become fully vested to the extent funded. The termination of the General Employees' Retirement System shall not result in the reduction of benefits under the Michigan Constitution. Upon termination of the General Employees' Retirement System, no further benefits shall accrue and no further contributions shall be made to the General Employees' Retirement System.

Upon termination of the General Employees' Retirement System and favorable determination by the Internal Revenue Service that the General Employees' Retirement System maintained its tax-favored status at the Termination Date, the Board is hereby directed to transfer the General Employees' Retirement System's assets and liabilities as follows:

- (a) As soon as administratively feasible after the Termination Date and the effective date of the Reestablished General Employees' Retirement System, the Board shall transfer the GERS Assets to the Reestablished General Employees' Retirement System in order to provide Retirement Allowances to Members, Retirants, and Beneficiaries. Such benefits will be based upon accrued benefits as of the Termination Date.
- (b) The Excess Assets resulting from erroneous actuarial computation shall be transferred to a voluntary employees' beneficiary association under Code §501(c)(9) (that has received a favorable determination letter as to the tax-exempt status of such trust under Code section 501(c)(9)) established or to be established by the City to fund retiree health benefits for certain City retirees that are subject to the Settlement Agreement.
- (c) All obligations and liabilities of the General Employees' Retirement System existing on the Termination Date, including continuation of payment of Retirement Allowances, are transferred to, assumed by, and made obligations and liabilities of the Reestablished General Employees' Retirement System upon transfer of the GERS Assets to the Reestablished General Employees' Retirement System.
- (d) For purposes of this Section, the followings terms shall have the following meaning:
 - (i) "*Excess Assets*" means the assets held within the General Employees' Retirement System on the Termination Date which exceed 130% of the General Employees' Retirement System's liabilities / obligations on that date.
 - (ii) "*GERS Assets*" means assets held within the General Employees' Retirement System on the Termination Date equal to 130% of the General Employees' Retirement System's liabilities / obligations on that date.
 - (iii) "*Settlement Agreement*" means the settlement agreement entered into in *City of Pontiac Retired Employees Association et. al. v. Schimmel et. al.*, Docket #64-2, Case No. 2:12-cv-12830-AC-PJK dated March 30, 2018 (United

States District Court Eastern District of Michigan), which was given final approval by the court on November 19, 2018.

- d. Section 38 [92-48] of the GERS is deleted in its entirety.
- e. Section 39 [92-49] of the GERS is deleted in its entirety.
- f. Section 40 [92-50] of the GERS is deleted in its entirety.

Section 2. Severability.

If any section, or provision of this Ordinance shall be declared to be unconstitutional, void, illegal, or ineffective by any Court of competent jurisdiction, such section, clause or provision declared to be unconstitutional, void or illegal shall thereby cease to be a part of this Ordinance, but the remainder of the Ordinance shall stand and be in full force and effect.

Section 3. Repealer.

All Ordinances or parts of Ordinances in conflict herewith are hereby repealed only to the extent necessary to give this Ordinance full force and effect.

Section 4. Publication.

The Clerk shall publish this Ordinance in a newspaper of general circulation.

Section 5. Effective Date.

This Ordinance shall be effective 10 days after adoption by the City Council.

I hereby certify that the foregoing is a true copy of the Ordinance as passed by the City Council of the City of Pontiac at a regular Council Meeting held in the City Council Chambers in said City on the _____ day of October, 2020.

Garland S. Doyle, Interim City Clerk

#7

RESOLUTION

MEMORANDUM

TO: Mayor Deirdre Waterman, Council President Williams, Members of Council

FROM: Matthew Gibb, Special Legal Counsel for Economic Development

DATE: October 15, 2020
For Council Meeting October 20, 2020

RE: **ECONOMIC DEVELOPMENT**

**RESOLUTION TO CONFIRM OBSOLETE PROPERTY
REHABILITATION EXEMPTION CERTIFICATE FOR KEVADIYA
PROPERTIES, LLC AT 100 N SAGINAW, EXTENDING THE TIME FOR
COMPLETION OF IMPROVEMENTS FOR ONE YEAR, AND
AMENDING THE BEGINNING DATE TO DECDEMBER 31, 2020**

On March 26, 2019 the City approved an application for an Obsolete Property Rehabilitation Exemption Certificate by public hearing for the property at 100 N Saginaw Street. The property is being restored by Kevadiya, and advanced engineering software company currently operating at 35 W Huron and planning to expand into the restored property, making the location its headquarters.

The 2019 approval included a Development Agreement that obligated Kevadiya to certain deliverables and deadlines, amongst those included the completion of improvements that would allow a reassessment of the property for the 2021 tax year. Difficulties have caused the project to be delayed including COVID and much of the following:

- The East foundation was collapsing and had to be entirely rebuilt.
- The failing foundation caused the brick to fall off the entire East wall.
- The original contractor made several errors, including failing to pull proper permits.
- The plans for the property were submitted in November 2019 but were not fully reviewed until June 2020.
- The structure, the walls, and the delays have caused the budget to crest and they are now in jeopardy of losing the project.

Once the plans were reviewed several deficiencies were found and Kevadiya is quickly revising the plans to meet the requests of the City. When approved, Kevadiya expects to complete the buildout by the spring. The project is necessary as Kevadiya is under contract requiring the expansion of its workforce to meet the work demand. They presently employ 30 people in Pontiac and intend to immediately hire an additional 10 engineers, with projections of continued hiring in 2021. Kevadiya has met, or is in the process of meeting, all other aspects of the Development Agreement.

**RESOLUTION TO CONFIRM OBSOLETE PROPERTY REHABILITATION EXEMPTION
CERTIFICATE FOR KEVADIYA PROPERTIES, LLC AT 100 N SAGINAW, EXTENDING THE
TIME FOR COMPLETION OF IMPROVEMENTS FOR ONE YEAR AND AMENDING THE
BEGINNING DATE TO DECEMBER 31, 2020**

Whereas, The City of Pontiac approved an application for Obsolete Property Rehabilitation Exemption Certificate for the property at 100 N Saginaw (Tax ID 14-29-426-012) by public hearing on March 26, 2019; and

Whereas, the City has been informed of practical difficulties to the property that caused a reasonable delay in completing the necessary improvements to occupy the property and cause the proper reassessment of the property in accord with Public Act 146 of 2000; and

Whereas, the COVID 19 pandemic and associated executive orders have further caused the project to be delayed through not fault of Kevadiya Properties, LLC; and

Whereas, the purpose and intent of the approval, and the support stated in the 2019 resolution supporting the approval, remain true and accurate and the requested extension fully supported by the record presented to the City of the present hardship in meeting the strict deadlines of the Act and approval; and

Whereas, an extension of the time for completion shall defer the required reassessment of the property by Oakland County Equalization for one year, allowing the property to receive the intended benefit of Public Act 146 of 2020.

NOW THEREFORE BE IT RESOLVED that the Obsolete Property Rehabilitation Act Exemption Certificate for the property known as 100 N Saginaw (Tax ID 14-29-426-012) is hereby confirmed and the time for completion of improvements is extended for one year from the date hereof;

IT IS FURTHER RESOLVED that the Exemption Certificate shall be amended to reflect a beginning date of December 31, 2020 and ending date of December 31, 2032 with all other terms remaining as stated, in accord with Public Act 146 of 2000, as amended.

Moved by _____

Supported By _____

Aye _____ Nay _____

DEVELOPMENT AGREEMENT

This Development Agreement ("Agreement") is effective as of March __, 2019, between the City of Pontiac ("City"), a Michigan municipal corporation, and Kevadiya Properties, LLC ("Owner"), a Michigan limited liability company and Kevadiya Inc. (Tenant), a Michigan Corporation

Recitals:

WHEREAS, the Owner has acquired title to real property commonly known as 100 N. Saginaw, Pontiac, in Oakland County, Michigan ("Property");

WHEREAS, the Owner desires to make substantial improvements to and redevelop the Property for future use ("Project");

WHEREAS, the Owner has requested an OPRA tax credit from the City of Pontiac to facilitate redevelopment of the Project;

WHEREAS, The Tenant will execute the Community Benefits per this agreement on behalf of the Owner,

WHEREAS, the City is executing this Agreement, to induce the Owner to redevelop a significant building in its downtown, and the parties acknowledge that development of the Project will contribute significantly to the economy of the City of Pontiac;

WHEREAS, the City's Mayor and City Council have determined that this Agreement is appropriate for the proposed development of the Project, is consistent with the public health, safety and welfare of the City's residents and businesses, and will result in positive impacts and benefits for the City and its residents and businesses; and

WHEREAS, the Owner's good faith estimate of the completion date for the Project is December 31, 2019 (the "Project Completion Date").

NOW THEREFORE, for good and valuable consideration, the adequacy, sufficiency and receipt of which is hereby acknowledged, the City and the Owner agree as follows:

1. **Recitals.** The Recitals as set forth herein are represented to be true and accurate and are hereby incorporated as material terms of this Agreement.

2. **No Preemption.** Unless otherwise expressly provided herein, this Agreement shall not be deemed to waive, preempt, supersede, or render ineffective any applicable municipal or governmental laws, ordinances, codes, regulations or processes, including but not limited to zoning, economic incentives, taxes, assessments or fees, and Owner shall be subject to all review and approval processes required under the City's ordinances, regulations and rules.

3. **Owner's Additional Requirements.** Owner Agrees as follows:

A. Should Owner proceed with the Project, to prepare and submit to the City plans and specifications (the "Plans") for the improvements (each an "Improvement", and collectively, the "Improvements") provided that no work on said Improvements shall be commenced until any necessary permit has been issued by the City's Building Safety Division or its designee.

B. To construct all improvements in accordance with the City's building code as approved by the City's Building Inspection Division.

C. Failure to comply with any of this development agreement's terms and conditions shall constitute a material breach of the Agreement and the parties each shall have all remedies in law and/or in equity necessary to ensure compliance by the other party.

4. **Contracts.** Owner shall provide City with letters from a licensed architect and licensed contractor confirming that they have been retained to assist with the development

5. **Community Benefits.**

A. In connection with the development and construction of the Project, the Owner has retained Pontiac Based Businesses to provide architectural, engineering, environmental and other professional and consulting firms services relating to the development and construction of the Project. For purposes of this Agreement, a "Pontiac Based Business" shall mean a business that is either (i) headquartered in the City, or (ii) has an office, store or other facility within the City. Owner shall require its general contractor to advertise available on-site jobs in local media and electronically on a City-sponsored website and social media, if such resources exist. In addition, Owner shall consult with and provide written notice to at least two (2) local hiring organizations, which may include non-profit organizations involved in referring eligible applicants for job opportunities, including through the Pontiac Jobs Pipeline which is operated through the City's Economic Development Department. Owner shall require its general contractor to consider in good faith all applications submitted by City residents and businesses and maintain a preference for hiring City residents and businesses that are qualified to perform the on-site jobs relating to the Project and construction of each component of the Project. Owner shall, in its agreements with its general contractor, include a requirement for this local hiring practice, and, in connection therewith, Owner will introduce such contractors to, and encourage such contractors to participate in, the "Community Ventures" program offered by the Michigan Economic Development Corporation.

B. Owner shall make all possible efforts to post notifications for residents of the City, which identify open positions.

C. Tenant shall work to provide internship opportunities to Pontiac High School students that are also City residents and that meet hiring requirements. These internships will be for a minimum of 10 hours per week and introduce the interns to practices searching for business opportunities.

D. Tenant shall work in conjunction with the City to identify fundraising opportunities to provide STEM programming at the Pontiac Youth Recreation and Employment Center. Given city support Owner will help initiate, manage team, and take responsibility for proper application for these government grants.

E. Owner agrees to spend not less than One Million Five Hundred Thousand Dollars (\$1,500,000), including building purchase price, on the Project by the time it is fully complete and occupied.

F. Owner and Tenant shall have created an economic benefit to the City taxpayers by redeveloping the Project and relocating their company, which will have employees that pay income taxes to the City.

G. Tenant will employ their expertise to develop a transportation plan for service from Pontiac schools to the Youth Center, as described in Exhibit A.

6. **Business Residency Requirement.** As a condition of receiving an OPRA, Owner agrees to operate the facility for which the certificate is granted for the term of the certificate. Should Owner vacate or fail to operate the facility for which the certificate is granted for the period of time outlined in this Section, then property tax savings benefiting the business due to the existence of the certificate can be revoked from the date the Owner vacated the facility.

7. **Building Development Requirement.** Owner shall devote all of the time, effort, resources and skill necessary for the development of the Project and further agrees to complete the following requirements (all of which shall occur as soon as reasonably practicable but in no event later than six (6) months after the receipt of all necessary City, County and State approvals for the approval of the OPRA. Owner shall submit all required documentation for the receipt of building permits to the City's Building Safety Division as follows:

A. Owner shall substantially complete repairs to the building enclosure located on the Property, including but not limited to, roof repair or replacement and compromised enclosure and asset preservation within Three Hundred sixty (360) days after issuance of the applicable building permit by the City's Building Safety Division.

B. Owner shall commence core and shell reconstruction so that the property is ready for tenant improvements within three hundred sixty (360) days after issuance of the applicable building permit by the City's Building Safety Division.

8. **Additional Requirements of City and Owner.** Both the City and Owner further agree as follows

A. This Agreement is not intended to create a contractual right for third parties.

B. This Agreement and any of its terms, conditions, or provisions cannot be modified, amended, or waived unless in writing and unless executed by both parties to this Agreement. Any

representations or statements, whether oral or in writing, not contained in this Agreement shall not be binding on either party.

C. This Agreement and any of its terms or conditions shall not be assigned or transferred to any other individual or entity unless prior written consent to such an assignment is received from City, which consent shall not be unreasonably withheld, conditioned or delayed. The City's failure to consent to a proposed assignment because the proposed assignee lacks the creditworthiness or development experience of the Owner shall not be deemed to be unreasonable. The City acknowledges that due to the nature and requirements from a lender or investor, a new entity may be formed for the sole purpose of completing this project, and if so, the City shall consent to the assignment of this agreement and the OPRA certificate to that entity if so needed.

D. This agreement shall be interpreted, enforced and governed under the laws of the State of Michigan and all applicable City ordinances. The venue for any action arising under this agreement shall be a court of appropriate jurisdiction in Oakland County.

E. This Agreement becomes null and void if the City doesn't approve a 12 year OPRA certificate.

9. **City Support.** The City shall, to the extent reasonably appropriate, support and reasonably cooperate with the Owner in connection with its development of the Project. This support includes, without limitation and as soon as reasonably practical; (i) cooperate with the Owner, wherever practical, in applying for Economic Development Incentives (defined below), other grants, benefits, awards, entitlements, licenses, consents, permits, approvals sought by the Owner in connection with the Project; (ii) submit to City Council, a resolution for the approval of the OPRA. For purposes of this Agreement, the term "Economic Development Incentives" specifically includes, but is not limited to, the following incentives: (i) Michigan Department of Environmental Quality Grant and Loan Programs; (ii) Michigan Economic Development Corporation/Michigan Strategic Fund Grant and Loan Programs, including the Community Revitalization Program ("CRP"); (iv) OPRA tax freeze; (v) Tenant Recruitment support to the downtown District and this Project; and (vi) Property Assessed Clean Energy ("PACE") through Oakland County.
10. **Binding Effect.** This Agreement shall be binding upon and inure to the benefit of the parties and their respective successors or assigns.
11. **Notice.** All notices, requests, consents and other communications under this Agreement must be in writing, shall be addressed to the receiving party's address set forth below or to any other address a party may designate by notice under this Agreement, and shall be either (i) delivered by hand, (ii) sent by nationally recognized overnight courier, or (iii) sent by certified mail, postage prepaid;

April 2, 2019 Approved Minutes

Ayes: Waterman, Williams, Pletila and Taylor-Burks

No: Miller

Resolution Passed.

19-117 Resolution to approve an Application for an Obsolete Property Rehabilitation Exemption Certificate for Kevadiya Properties, LLC at 84-100 N. Saginaw (Tax Parcel Number; 14-29-426-012) for 12 years, beginning December 31, 2019, and ending December 30, 2031, Pursuant to the Provisions of PA 146 of 2000, as amended. Moved by Councilperson Waterman and second by Councilperson Pletila.

WHEREAS, pursuant to PA 146 of 2000, as amended, the City of Pontiac is a Qualified Local Governmental Unit eligible to establish one or more Obsolete Property Rehabilitation Districts; and

WHEREAS, the City of Pontiac legally established the Obsolete Property Rehabilitation District on December 19, 2002; and

WHEREAS, the taxable value of the property proposed to be exempt plus the aggregate taxable value of property already exempt under Public Act 146 of 2000 and under Public Act 198 of 1974 does not exceed 5% of the total taxable value of the City of Pontiac; and

WHEREAS, the application was approved at a public hearing as provided by section 4(2) of Public Act 146 of 2000 on March 26, 2019; and

WHEREAS, the applicant is not delinquent in any taxes related to the facility; and

WHEREAS, the application is for obsolete property as defined in section 2(h) of Public Act 146 of 2000; and

WHEREAS, the applicant Kevadiya Properties, LLC has provided answers to all required questions under the application instructions to the City of Pontiac; and

WHEREAS, the City of Pontiac requires that rehabilitation of the facility shall be completed by December 31, 2019; and

WHEREAS, the commencement of the rehabilitation of the facility did not occur before the establishment of the Obsolete Property Rehabilitation District; and

WHEREAS, the application relates to a rehabilitation program that when completed constitutes a rehabilitated facility within the meaning of Public Act 146 of 2000 and that is situated within an Obsolete Property Rehabilitation District established in the City of Pontiac eligible under Public Act 146 of 2000 to establish such a district; and

WHEREAS, completion of the rehabilitated facility is calculated to, and will at the time of issuance of the certificate, have the reasonable likelihood to create employment in which the facility is situated; and

April 2, 2019 Approved Minutes

WHEREAS, the use of this property shall be restricted to non-marihuana related uses during the effective period of the OPRA Certificate. Shall use of the property become marihuana related, the OPRA Certificate shall be immediately revoked by the City; and

WHEREAS, the rehabilitation includes improvements aggregating 10% or more of the true cash value of the property at commencement of the rehabilitation as provided by section 2(1) of Public Act 146 of 2000,

NOW, THEREFORE, BE IT RESOLVED by the City Council of the City of Pontiac

Be and hereby is granted an Obsolete Property Rehabilitation Exemption for the real property, excluding land, located in the Obsolete Property Rehabilitation District at 84-100 N. Saginaw (Tax Parcel Number: 14-29-426-012) for 12 years, beginning December 31, 2019, and ending December 30, 2031, pursuant to the provisions of PA146 of 2000, as amended.

Ayes: Williams, Pietila, Taylor-Burks and Waterman
No: Miller
Resolution Passed.

Resolution to reinstate the salary for the Deputy Director of Community Development to \$73,892 as originally budgeted in Fiscal Year 2018-19 was removed from the agenda.

Communications from the Mayor

Received Mayoral Appointment – Mr. Hugely Newsome as Finance Director effective April 15, 2019 pending approval by City Council. Interview is set for April 9, 2019.

Received Mayoral Proclamation to Proclaim April 2019 as Child Abuse Prevention and Awareness Month in the City of Pontiac.

Received Mayoral Proclamation to Recognize National Week of the Young Child April 8-12, 2019.

Received updated report regarding Council President Williams request regarding City Employee's Mileage Reimbursement Policy for Employees who receive Mileage if they traveling less than 50 miles one-way on City Business. The Interim City Clerk corrected the Deputy Mayor's Report. The report stated that the City Clerk had been given a copy of the "Vehicle Use Reimbursement Policy memo (dated March 26, 2019) for inclusion and distribution in the City Council agenda package for March 26th City Council agenda." This statement is untrue. The policy was distributed by the Deputy Mayor at the City Council Meeting on March 26, 2019. The Clerk had not been given the policy before the meeting.

ADDRESS

3363 Vineyard Hill
Dr. Rochester, MI 48306

City Council, City of Pontiac
City Hall
47450 Woodward Ave.
Pontiac, MI
Date: Oct 12, 2020

RE: Extension of Obsolete Property Rehabilitation –
Exception Certificate Project Competition Date for 100 N Saginaw Pontiac, MI 48342

Dear City of Pontiac Council Members,

City Council of Pontiac previously approved the motion to grant Obsolete Property Rehabilitation Exception Certificate to Kevadiya Properties LLC for developing 84-100 N Saginaw, Pontiac, MI 48343 property. The property rehabilitation was immediately started in Summer of 2019. All the drawings for property remodeling were submitted to the Engineering Department by fall 2019 as well. Despite all our efforts, Kevadiya Properties LLC was not able to reach its objective to complete the rehabilitation of the building and therefore request an extension of the certificate terms to allow completion of the project by June 2021. Here are the reasons for delay in rehabilitation –

- During the interior demolition, we performed the asbestos study which uncovered areas where asbestos was used beyond allowable limits. We had to hire contractor for systematic asbestos removal which delayed the demolition by couple of months.
- During interior demolition, engineers found structural issues due to backwall sinking. The remediation required us to perform soil test and structural engineering drawings and installation of foundation support. The activity to reestablish support of building pushed our interior build-out efforts to February 2020.
- Since the building power requirements changed, application to install a new transformer and switch board was submitted to DTE in fall 2019. Due to backlog, DTE could not plan the new electrical connections until February, however immediately we were impacted by the COVID crisis which further delayed all DTE activities until just recently now. The new power upgrade by DTE is planned to be completed by Oct. 15, 2020.
- Without structural fix and electrical upgrades, we were not able to start on interior build-out, however due to COVID no activities were allowed beyond Feb. 2020, which has added significantly to delay in completion of the project.

Thus far, the rehabilitation efforts have completed following update activities.

- Complete demolition of interior.
- Removal all bricks in the back of the building which was separated from wall due to building sinking.
- Asbestos removal.
- Structural support of 80000 pounds to the building foundation.
- Reinforcements of interior building's failed beams and columns.
- New roof.
- New HVAC units for the entire building.
- Removal of all steel panels covering the building façade in front.
- Upgraded and completely new 240v / 3000kva electrical connections from DTE
- Partial interior framing
- Backwall and front façade to be completed by end of Oct.
- All new windows to be installed by Nov. 15, 2020.

Remaining project rehabilitation work:

- Interior buildout
- Parking lot
- Elevator

We expect all remaining tasks to be completed by June 2021 and possession be granted to Kevadiya Inc. for moving all the employees to the modernized building. It shall be noted that Kevadiya Properties LLC and Kevadiya Inc. are course of meeting project requirements. For example, the property rehabilitation expense at this state is estimated above \$1.5M with its acquisition cost. Kevadiya Inc is expanding its business and hiring 5 new positions. All postings are made available on City of Pontiac job link pages. In Sept. 2020, Kevadiya Inc hired a resident of Pontiac as an employee. In addition, Kevadiya Inc. is encouraging its employees to locate within the city. As of today, we have 2 of our employees living in the City of Pontiac.

Kevadiya Properties LLC understands the importance of this project and would like its completion as soon as possible. However, unforeseen and unfavorable conditions have delayed the project beyond our control. We request that the City Council look at these conditions and grant us an extension to complete the project by June 2021.

Sincerely,

Nilesh Patel

Digitally signed by Nilesh
Patel
Date: 2020.10.12 13:43:12
-04'00'

Nilesh Patel

#8

RESOLUTION



MEMORANDUM

City of Pontiac
Treasurer

47450 Woodward Avenue
Pontiac, Michigan 48342
Telephone: (248) 758-3063
Fax: (248) 758-3177

DATE : 10/21/2020

TO: Honorable Mayor and City Council

FROM: Sekar Bawa, Treasurer - Finance

THROUGH: Irwin Williams – Finance Director

SUBJECT: Drain assessment to be paid from General Fund

Attached is a summary report from the Water Resource Commissioner's office that shows the Chapter 4 drain assessments to be paid by the City of Pontiac in the amount of \$76,562.41. This total includes \$19,177.60 that could be spread to the property owners that border the related drains and lakes.

There are 6,901 total parcels that would be assessed a charge, 515 non-residential and 6,386 residential parcels. As the table given below shows, the 99% of residential parcels will be assessed an average drain charge from \$0.24 to \$17.65 for the fiscal year 2020. Alternatively, this drain assessment can be paid from the General Fund to give small relief to our residents at this difficult time. This will not have significant impact on our general fund unassigned fund balance.

This assessment will be the responsibility of the General Fund in addition to the Chapter 20 and Chapter 4 at large assessments.

If Council agrees that this assessment should be paid from the General Fund, then the following resolution would be in order:

Whereas, the Water Resources Commissioner has notified the City of property assessments for nearly 6,901 parcels in the City of Pontiac that specifically benefited the property owner; and,

Whereas, the Pontiac City Council believes that this drain assessment should be paid from the General Fund to give relief to the city residents at this current pandemic;

Now, therefore, be it resolved, that the Pontiac City Council direct that the Finance Director pay \$19,177.60 from the General Fund.

Drain Name	At Large	Residitlal			Non Residential			Combined Total	
		No of Parcels	Average	Total	No of Parcels	Average	Total	No of Parcels	Total
BARTLETT DRAIN	\$ 640.75	647	\$ 0.57	\$ 365.90	75	\$ 15.30	\$ 1,147.70	722	\$ 2,154.35
CRYSTAL LAKE LEVEL	\$ 17,500.00							0	\$ 17,500.00
GALLOWAY DRAIN	\$ 175.33	75	\$ 3.17	\$ 237.56	4	\$ 129.67	\$ 518.66	79	\$ 931.55
JEWEL DRAIN	\$ -	1233	\$ 0.78	\$ 966.94	123	\$ 12.46	\$ 1,533.06	1356	\$ 2,500.00
PONTIAC CREEK EXT DRAIN	\$ 3,291.75	64	\$ 17.65	\$ 1,129.66	35	\$ 84.33	\$ 2,951.40	99	\$ 7,372.81
SINKING BRIDGE DRAIN	\$ 266.50	2104	\$ 0.24	\$ 514.10	180	\$ 4.12	\$ 741.73	2284	\$ 1,522.33
SYLVAN-OTTER LAKE LEVEL	\$ 30,000.00	367	\$ 3.91	\$ 1,434.99	6	\$ 68.63	\$ 411.78	373	\$ 31,846.77
TILDEN DRAIN	\$ 596.73	284	\$ 2.82	\$ 800.77	14	\$ 8.72	\$ 122.02	298	\$ 1,519.52
TUTTLE DRAIN	\$ -	5	\$ 1.44	\$ 7.22				5	\$ 7.22
WARD ORCHARD DRAIN	\$ 10.00	2	\$ 0.50	\$ 1.01	7	\$ 6.10	\$ 42.73	9	\$ 53.74
WATERFORD - MULTI LAKE LEVEL	\$ -	11	\$ 106.13	\$ 1,167.43				11	\$ 1,167.43
WEST END DRAIN	\$ 4,903.75	1594	\$ 2.00	\$ 3,182.92	71	\$ 26.76	\$ 1,900.02	1665	\$ 9,986.69
Grand Total	\$ 57,384.81	6,386	\$ 1.54	\$ 9,808.50	515	\$ 18.19	\$ 9,369.10	6,901	\$ 76,562.41



WRC

WATER RESOURCES COMMISSIONER

Jim Nash

September 8, 2020

The Honorable Sekar Bawa
 City of Pontiac
 47450 Woodward Avenue
 Pontiac, MI 48342

Reference: → Preliminary 2020 Special Assessments for Oakland County Drains / Lake Level Control Facilities

Dear Mr. Sekar:

This letter is intended to inform you of the special assessment amounts for the operation and maintenance of Oakland County drains and lake level control facilities located in your community. Several reports are attached that provide detailed information regarding the special assessment amounts that will appear on the 2021 winter tax bill for your residents and the amount due from your community.

If your community pays the county drain special assessments from your general fund and does not spread the assessment to the tax rolls, please continue to pay the special assessment amounts as summarized below.

PROJECT CODE AND NAME		AT LARGE	PROPERTY	TOTAL	
D1059	BARTLETT DRAIN	\$640.75	\$1,513.60	\$2,154.35	
L0667	CRYSTAL LAKE LEVEL	\$17,500.00	\$0.00	\$17,500.00	
D0115	GALLOWAY DRAIN	\$175.33	\$756.22	\$931.55	
D1107	JEWEL DRAIN	\$0.00	\$2,500.00	\$2,500.00	
D0220	PONTIAC CREEK EXT DRAIN	\$3,291.75	\$4,081.06	\$7,372.81	
D0258	SINKING BRIDGE DRAIN	\$266.50	\$1,255.83	\$1,522.33	
L0283	SYLVAN-OTTER LAKE LEVEL	\$30,000.00	\$1,846.77	\$31,846.77	
D0350	TILDEN DRAIN	\$596.73	\$922.79	\$1,519.52	
D0326	TUTTLE DRAIN	\$0.00	\$7.22	\$7.22	
D1053	WARD ORCHARD DRAIN	\$10.00	\$43.74	\$53.74	
L0458	WATERFORD - MULTI LAKE LEVEL	\$0.00	\$1,167.43	\$1,167.43	
D0313	WEST END DRAIN	\$4,903.75	\$5,082.94	\$9,986.69	
		Subtotal:	\$57,384.81	\$19,177.60	\$76,562.41



Please contact Scott Vess, Deputy Oakland County Treasurer, at 248-858-0616 with any questions concerning payment of the special assessment. If you would like to use this letter to pay the assessments, then please use the reference above with your community name and send to:

Oakland County Treasurer
1200 N Telegraph Rd Dept 479
Pontiac, MI 48341

Thank you for your attention to this issue.

Sincerely,



Michael R. McMahon, P.E.
Chief Engineer

c: Scott Vess, Oakland County Treasurer's Office



WRC

WATER RESOURCES COMMISSIONER

Jim Nash

September 8, 2020

The Honorable Sekar Bawa
 City of Pontiac
 47450 Woodward Avenue
 Pontiac, MI 48342

Reference: Preliminary 2020 Special Assessments for Oakland County Drains / Lake Level Control Facilities

Dear Mr. Sekar:

This letter is intended to inform you of the special assessment amounts for the operation and maintenance of Oakland County drains and lake level control facilities located in your community. Several reports are attached that provide detailed information regarding the special assessment amounts that will appear on the 2021 winter tax bill for your residents and the amount due from your community.

If your community pays the county drain special assessments from your general fund and does not spread the assessment to the tax rolls, please continue to pay the special assessment amounts as summarized below.

PROJECT CODE AND NAME		AT LARGE	PROPERTY	TOTAL
D1059	BARTLETT DRAIN	\$640.75	\$1,513.60	\$2,154.35
L0667	CRYSTAL LAKE LEVEL	\$17,500.00	\$0.00	\$17,500.00
D0115	GALLOWAY DRAIN	\$175.33	\$756.22	\$931.55
D1107	JEWEL DRAIN	\$0.00	\$2,500.00	\$2,500.00
D0220	PONTIAC CREEK EXT DRAIN	\$3,291.75	\$4,081.06	\$7,372.81
D0258	SINKING BRIDGE DRAIN	\$266.50	\$1,255.83	\$1,522.33
L0283	SYLVAN-OTTER LAKE LEVEL	\$30,000.00	\$1,846.77	\$31,846.77
D0350	TILDEN DRAIN	\$596.73	\$922.79	\$1,519.52
D0326	TUTTLE DRAIN	\$0.00	\$7.22	\$7.22
D1053	WARD ORCHARD DRAIN	\$10.00	\$43.74	\$53.74
L0458	WATERFORD - MULTI LAKE LEVEL	\$0.00	\$1,167.43	\$1,167.43
D0313	WEST END DRAIN	\$4,903.75	\$5,082.94	\$9,986.69
	Subtotal:	\$57,384.81	\$19,177.60	\$76,562.41



Please contact Scott Vess, Deputy Oakland County Treasurer, at 248-858-0616 with any questions concerning payment of the special assessment. If you would like to use this letter to pay the assessments, then please use the reference above with your community name and send to:

Oakland County Treasurer
1200 N Telegraph Rd Dept 479
Pontiac, MI 48341

Thank you for your attention to this issue.

Sincerely,

A handwritten signature in cursive script that reads "Michael R. McMahon".

Michael R. McMahon, P.E.
Chief Engineer

c: Scott Vess, Oakland County Treasurer's Office

#9

RESOLUTION



MEMORANDUM

City of Pontiac

Treasurer

47450 Woodward Avenue

Pontiac, Michigan 48342

Telephone: (248) 758-3063

Fax: (248) 758-3177

DATE : 09/29/2020

TO: Honorable Mayor and City Council

FROM: Sekar Bawa, City Treasurer

THROUGH: Irwin Williams – Finance Director

SUBJECT: Special Assessment to be levied on Tax Roll

As part of our yearly preparation for audit, we closely examined our outstanding receivables list. The list identified all unpaid invoices for grass cutting, litter cleanup, nuisance and demo OC. According to the Code of Ordinances section 98-21, these charges, if remain unpaid, shall be assessed against the lot as a single lot assessment. Section 98-22 requires that if an invoice is unpaid, parcel, owner, and amount shall be reported to City Council. Section 98-23, states after review by the City Council, the Council may act to have the unpaid invoices spread on the tax rolls.

We have established a cutoff date of September 15, 2020 as a final date that these assessments should be paid before we, upon council authorization, place them on the Winter 2020 tax rolls for collection. Current record shows balance as given below:

Demolition	\$ 3,650.00
Grass cutting	\$ 38,705.00
Litter cleanup	\$ 2,425.60

Total	\$44,780.60

If Council agrees that the above special assessments should be spread to the tax rolls, then the following resolution would be in order:

Whereas, the Pontiac City Council believes that it is in the best interest of the City, that property owners who receive a direct benefit from the grass cutting, litter cleanup, demo and nuisance ordinance should pay for the benefit;

Now, therefore, be it resolved, that the Pontiac City Council directs that the City Treasurer spread \$44,780.60 of aged special assessment receivable on the 2020 winter tax rolls.

09/28/2020
12:16 PM

Tax Assignment Report for City of Pontiac
Trial Run

Page: 1/3
DE: Pontiac

Cust ID Invoice #	Customer Name Post Date Billing Item	Item Code	Balance	Additional	Tot Transferred
64-14-07-480-010 19-0007342	Ramseyer, Erik 09/24/2019 DemoCC	DemoCC	1950.00 1950.00	0.00 0.00	1950.00 1950.00
64-14-21-405-006 19-0007341	Aaronco Management Co. Inc. 09/24/2019 DemoCC	DemoCC	450.00 450.00	0.00 0.00	450.00 450.00
64-19-05-226-004 19-0007343	Smart Living Solutions 09/24/2019 DemoCC	DemoCC	1250.00 1250.00	0.00 0.00	1250.00 1250.00
----->	Totals DemoCC		3,650.00		
----->	Grand Total		3,650.00		

09/28/2020
10:45 AM

Tax Assignment Report for City of Pontiac
Trial Run

Page
#

Cust ID Invoice #	Customer Name Post Date Billing Item	Item Code	Balance	Additional	Tot Transferred
64-14-08-455-007 20-0007767	Bermudez, Cesar 03/17/2020 LCUP	Litter	62.88 62.88	0.00 0.00	62.88 62.88
64-14-16-306-033 20-0007772	Johnson, Cami Alycia 03/17/2020 LCUP	Litter	62.88 62.88	0.00 0.00	62.88 62.88
64-14-16-327-015 20-0007775	Cole, Portia D 03/18/2020 LCUP	Litter	62.88 62.88	0.00 0.00	62.88 62.88
64-14-20-309-031 20-0007716	Park Terrace Properties 02/26/2020 LCUP	Litter	292.88 292.88	0.00 0.00	292.88 292.88
64-14-21-303-027 19-0007529	SK Pontiac Housing LLC 11/22/2019 LCUP	Litter	182.27 182.27	0.00 0.00	182.27 182.27
64-14-21-377-034 20-0007769	Tarskaya, Elvira 03/17/2020 LCUP	Litter	62.88 62.88	0.00 0.00	62.88 62.88
64-14-22-152-023 20-0007774	Stormer, John 03/18/2020 LCUP	Litter	62.88 62.88	0.00 0.00	62.88 62.88
64-14-22-352-011 20-0007715	Barouch, Hubert 02/26/2020 LCUP	Litter	292.88 292.88	0.00 0.00	292.88 292.88
64-14-27-151-005 19-0007429	Leak, Elnora 11/04/2019 LCUP	Litter	212.27 212.27	0.00 0.00	212.27 212.27
64-14-28-380-019 20-0007701	Lombardo, Peter 02/05/2020 LCUP	Litter	62.88 62.88	0.00 0.00	62.88 62.88
64-14-29-482-009 19-0007434	Zeele, Patrick 11/05/2019 LCUP	Litter	62.27 62.27	0.00 0.00	62.27 62.27
64-14-29-483-015 19-0007432	Fredrick T Quinn 11/04/2019 LCUP	Litter	162.27 162.27	0.00 0.00	162.27 162.27
64-14-29-103-008 20-0007703	Ruggles, Dorothy M 02/05/2020 LCUP	Litter	212.27 212.27	0.00 0.00	212.27 212.27
64-14-29-152-010 20-0007764	Klein, Robert 03/17/2020 LCUP	Litter	62.88 62.88	0.00 0.00	62.88 62.88
64-14-29-356-001 19-0007428	Jim Stella Art, LLC 11/04/2019 LCUP	Litter	82.27 82.27	0.00 0.00	82.27 82.27

09/28/2020
10:45 AM

Tax Assignment Report for City of Pontiac
Trial Run

1

Cust ID Invoice #	Customer Name Post Date	Billing Item	Item Code	Balance	Additional	Tot Transferred
64-14-30-477-013 20-0007762	EV Cleaning & Investments, LLC 03/17/2020	LCUP	Litter	62.88 62.88	0.00 0.00	62.88 62.88
64-14-31-106-001 20-0007765	Dodson, Anita L 03/17/2020	LCUP	Litter	62.88 62.88	0.00 0.00	62.88 62.88
64-14-31-234-017 19-0007533	RE Fund Lansing I LLC 11/22/2019	LCUP	Litter	112.27 112.27	0.00 0.00	112.27 112.27
64-14-31-381-011 20-0007761	TCS Homes LLC 03/17/2020	LCUP	Litter	122.88 122.88	0.00 0.00	122.88 122.88
64-14-31-457-003 20-0007763	Zuhause Real Estate LLC 03/17/2020	LCUP	Litter	62.88 62.88	0.00 0.00	62.88 62.88
64-19-04-104-019 19-0007530	Lane Jr, Joe 11/22/2019	LCUP	Litter	62.27 62.27	0.00 0.00	62.27 62.27
----->	Totals Litter			2,425.60		
----->	Grand Total			2,425.60		

09/29/2020
01:56 PM

Billing Register for City of Pontiac
Population: All Records

Page: 1/9
DB: Pontiac

Invoices # Customer # Parcel #	Srvc Code	Owner Prop. Address	Mailing Address	Amt. Chg. Fmts/Crdts	Amt. Billed Amt. Due
19-0007364 64-14-33-210-043 64-14-32-210-043	GRASS	Gilmore, Brian 377 Osmun St Pontiac, MI	377 Osmun St Pontiac, MI	235.00 0.00	235.00 235.00
19-0007365 64-14-33-232-018 64-14-32-232-018	GRASS	Black, Alonso D 263 S Marshall St Pontiac, MI	11903 Ambrose Lane Fort Washington, MD	235.00 0.00	235.00 235.00
19-0007366 64-14-28-434-026 64-14-28-434-026	GRASS	Martinez, Veronica 65 S Marshall St Pontiac, MI	472 Harper St Pontiac, MI	370.00 0.00	370.00 370.00
19-0007367 64-14-33-133-006 64-14-33-133-006	GRASS	Tate, Timothy 37 Park Pl Pontiac, MI	37 Park Pl Pontiac, MI	235.00 0.00	235.00 235.00
19-0007368 64-14-29-257-012 64-14-29-257-012	GRASS	Elephant Ink LLC N Saginaw Pontiac, MI	111 N Ferry St Pontiac, MI	370.00 0.00	370.00 370.00
19-0007369 64-14-29-226-004 64-14-29-226-004	GRASS	Boyer, Peter 402 N Saginaw Pontiac, MI	8899 Tackles Ct White Lake, MI	235.00 0.00	235.00 235.00
19-0007374 64-14-17-333-028 64-14-17-333-028	GRASS	Young, Heaven Baldwin Pontiac, MI	6990 Hatchesy Rd Waterford, MI	370.00 0.00	370.00 370.00
19-0007377 64-14-16-426-026 64-14-16-426-026	GRASS	Balcher, Jamey 755 4th Ave Pontiac, MI	3834 Westlyn Dr Lake Orion, MI	235.00 0.00	235.00 235.00
19-0007378 64-14-22-106-016 64-14-22-106-016	GRASS	Delosangeles, Victor 621 Robinwood St Pontiac, MI	16372 Lower Harbor Rd Brookings, OR	235.00 0.00	235.00 235.00
19-0007380 64-14-21-329-026 64-14-21-329-026	GRASS	Goldman, Ezra N 145 Oliver St Pontiac, MI	6010 Charles Dr West Bloomfield, MI	235.00 0.00	235.00 235.00
19-0007381 64-14-22-431-002 64-14-22-431-002	GRASS	Huesbitt, Scott Boyd Pontiac, MI	650 Boyd St Pontiac, MI	235.00 0.00	235.00 235.00
19-0007382 64-14-22-302-002 64-14-22-302-002	GRASS	Newman, Bertha 18 Manhattan ST Pontiac, MI	650 Erady Lane Pontiac, MI	370.00 0.00	370.00 370.00
19-0007383 64-14-21-377-035 64-14-21-377-035	GRASS	Dias Leon Chavez, Migu 467 Omar St Pontiac, MI	271 Michigan Ave Pontiac, MI	235.00 0.00	235.00 235.00
19-0007384 64-14-30-330-004 64-14-30-330-004	GRASS	American Estate and Tr 196 Oganaw RD Pontiac, MI	6900 Westcliff Dr Ste Las Vegas, NV	235.00 0.00	235.00 235.00
19-0007385 64-14-30-402-013 64-14-30-402-013	GRASS	Brown, Eric 29 Spokane Dr Pontiac, MI	1998 Emerald Dr Jonesboro, GA	235.00 0.00	235.00 235.00
19-0007386 64-14-29-151-005 64-14-29-151-005	GRASS	Reeroot Pontiac N Johnson Pontiac, MI	76 Henderson St Pontiac, MI	235.00 0.00	235.00 235.00
19-0007387 64-14-30-427-018 64-14-30-427-018	GRASS	Miskey, Steven A 127 Thorpe St Pontiac, MI	17403 Winthrop St Detroit, MI	235.00 0.00	235.00 235.00
19-0007436 64-14-21-329-014 64-14-21-329-014	GRASS	Golonska, Diane E 260 Nelson ST Pontiac, MI	260 Nelson Street Pontiac, MI	235.00 0.00	235.00 235.00
19-0007437 64-14-21-329-026 64-14-21-329-026	GRASS	Goldman, Ezra N 145 Oliver St Pontiac, MI	6010 Charles Dr West Bloomfield, MI	165.00 0.00	165.00 165.00
19-0007438 64-14-22-456-011 64-14-22-456-011	GRASS	Sykes, Barry 1172 Eckman Ave Pontiac, MI	1172 Eckman Ave Pontiac, MI	235.00 0.00	235.00 235.00

09/29/2020
01:56 PM

Billing Register for City of Pontiac
Population: All Records

Page: 2/9
City of Pontiac

Invoices # Customer # Parcel #	Srvc Code	Owner Prop. Address	Mailing Address	Amnt. Chg. Fmts/Crds	Amnt. Billed Amnt. Due
19-0007439 64-14-17-152-001 64-14-17-152-001	GRASS	EBEE LLC 1290 Stanley Ave Pontiac, MI	3940 Hillsdale Dr Auburn Hills, MI	165.00 0.00	165.00 165.00
19-0007440 64-19-05-278-035 64-19-05-278-035	GRASS	Robinson, Ruby Y 482 Ditmar Ave Pontiac, MI	22 Franklin Rd Pontiac, MI	505.00 0.00	505.00 505.00
19-0007442 64-99-00-930-068 64-99-00-930-068	GRASS	Laundry Lounge 600 W Huron St Pontiac, MI	600 W Huron St Pontiac, MI	230.00 0.00	230.00 230.00
19-0007443 64-19-05-278-034 64-19-05-278-034	GRASS	Robinson, Ruby Y Franklin Rd Pontiac, MI	22 Franklin Blvd Pontiac, MI	235.00 0.00	235.00 235.00
19-0007444 64-14-28-408-013 64-14-28-408-013	GRASS	Abusaad, Kawther Mohd N Tasmania Pontiac, MI	615 61st Street Tuscaloosa, AL	235.00 0.00	235.00 235.00
19-0007445 64-14-34-102-012 64-14-34-102-012	GRASS	Sapienza, Vince F 142 Russell St Pontiac, MI	142 Russell St Pontiac, MI	235.00 0.00	235.00 235.00
19-0007446 64-14-34-156-007 64-14-34-156-007	GRASS	Elshely, Bennie 363 Seward St Pontiac, MI	1315 Groggys St SE Grand Rapids, MI	235.00 0.00	235.00 235.00
19-0007447 64-14-27-231-002 64-14-27-231-002	GRASS	Martin, Donna 68 Hilldale Dr Pontiac, MI	578 Lenox Ave Pontiac, MI	235.00 0.00	235.00 235.00
19-0007448 64-14-22-182-032 64-14-22-182-032	GRASS	Gauthier, James F 661 Robinwood St Pontiac, MI	661 Robinwood Pontiac, MI	235.00 0.00	235.00 235.00
19-0007449 64-14-22-381-012 64-14-22-381-012	GRASS	Himansha, Patel 410 Emerson Ave Pontiac, MI	2561 Simpson Dr Rochester, MI	235.00 0.00	235.00 235.00
19-0007450 64-14-21-257-022 64-14-21-257-022	GRASS	Chaves, Caspoforo 891 Spence St Pontiac, MI	891 Spence St Pontiac, MI	235.00 0.00	235.00 235.00
19-0007451 64-14-21-255-002 64-14-21-255-002	GRASS	E Kennett 618 618 E Kennett Rd Pontiac, MI	618 E Kennett Rd Pontiac, MI	235.00 0.00	235.00 235.00
19-0007452 64-14-16-408-025 64-14-16-408-025	GRASS	Valdez, Kristiana 875 4th Avenue Pontiac, MI	675 4th Ave Pontiac, MI	235.00 0.00	235.00 235.00
19-0007453 64-14-33-156-002 64-14-33-156-002	GRASS	Grand Trunk Western RR 45987 Woodward Pontiac, MI	2602 Laverne Rd., St Troy, MI	370.00 0.00	370.00 370.00
19-0007454 64-19-05-207-032 64-19-05-207-032	GRASS	Lenoir, Lazarus 582 California Ave Pontiac, MI	80 Mariva Street Pontiac, MI	235.00 0.00	235.00 235.00
19-0007455 64-19-05-204-011 64-19-05-204-011	GRASS	Simpson, Timmie 565 Nevada Ave Pontiac, MI	565 Nevada Ave Pontiac, MI	165.00 0.00	165.00 165.00
19-0007457 64-14-22-376-023 64-14-22-376-023	GRASS	Omicron Alpha Alpha Om Featherstone Pontiac, MI	PO Box 430744 Pontiac, MI	165.00 0.00	165.00 165.00
19-0007458 64-14-22-378-032 64-14-22-378-032	GRASS	Omicron Alpha Alpha Om Featherstone Pontiac, MI	PO Box 430744 Pontiac, MI	165.00 0.00	165.00 165.00
19-0007459 64-14-22-378-033 64-14-22-378-033	GRASS	Omicron Alpha Alpha Om Featherstone Pontiac, MI	PO Box 430744 Pontiac, MI	165.00 0.00	165.00 165.00
19-0007460 64-14-22-376-034 64-14-22-376-034	GRASS	Omicron Alpha Alpha Om Featherstone Pontiac, MI	PO Box 430744 Pontiac, MI	165.00 0.00	165.00 165.00

09/29/2020
01:56 PM

Billing Register for City of Pontiac
Population: All Records

Page: 3/9
09: Pontiac

Invoice # Customer # Parcel #	Srvc Code	Owner Prop. Address	Mailing Address	Amt. Chg. Fmts/Crdts	Amt. Billed Amt. Due
19-0007461 64-14-22-380-532 64-14-22-380-532	GRASS	Omicron Alpha Alpha Om Featherstone Pontiac, MI	PO Box 420744 Pontiac, MI	165.00 0.00	165.00 165.00
19-0007462 64-14-22-380-033 64-14-22-380-033	GRASS	Omicron Alpha Alpha Om Featherstone Pontiac, MI	PO Box 420744 Pontiac, MI	165.00 0.00	165.00 165.00
19-0007463 64-14-22-176-006 64-14-22-176-006	GRASS	Clarke, Ana May E 714 Kenilworth Pontiac, MI	2175 Hempstead Rd Auburn Hills, MI	235.00 0.00	235.00 235.00
19-0007464 64-14-22-331-010 64-14-22-331-010	GRASS	New Liberty Apostolic 104 N Jessie St Pontiac, MI	104 N Jessie St Pontiac, MI	235.00 0.00	235.00 235.00
19-0007465 64-14-20-126-027 64-14-20-126-027	GRASS	Douglas, Shelia 106 Dresden AVE Pontiac, MI	5675 S Baldwin Rd #197 Lake Orion, MI	235.00 0.00	235.00 235.00
19-0007466 64-14-21-230-204 64-14-21-230-204	GRASS	SK Pontiac Assets LLC 356 Nelson St Pontiac, MI	28125 26 Mile Rd Lenox, MI	235.00 0.00	235.00 235.00
19-0007468 64-14-22-335-004 64-14-22-335-004	GRASS	Anthony, Mary E 16 N Paddock ST Pontiac, MI	16 N Paddock Sp Pontiac, MI	235.00 0.00	235.00 235.00
19-0007469 64-14-33-185-001 64-14-33-185-001	GRASS	Victorious Christian I 391 S Paddock St Pontiac, MI	1753 Kristina Dr White Lake, MI	505.00 0.00	505.00 505.00
19-0007470 64-14-22-208-001 64-14-22-208-001	GRASS	New Star Investments, 58 Mechanic St Pontiac, MI	11660 E 11 Mile Rd Warren, MI	370.00 0.00	370.00 370.00
19-0007472 64-14-22-402-005 64-14-22-402-005	GRASS	49730 LLC 49730 Woodward Ave Pontiac, MI	1400 Rankin Dr Troy, MI	235.00 0.00	235.00 235.00
19-0007474 64-14-04-127-004 64-14-04-127-004	GRASS	Love Jr., Roy C 38 Hillsmont Ave Pontiac, MI	1074 Nature Trail Waterford, MI	235.00 0.00	235.00 235.00
19-0007475 64-14-22-206-008 64-14-22-206-008	GRASS	Wright, Vince 472 University Dr Pontiac, MI	309 Arnold Ave Pontiac, MI	370.00 0.00	370.00 370.00
19-0007476 64-14-20-107-017 64-14-20-107-017	GRASS	Hogg, Ryan S Macrimac Pontiac, MI	25117 176th Ave E Orting, WA	370.00 0.00	370.00 370.00
19-0007479 64-14-22-125-001 64-14-22-125-001	GRASS	Little Bunnys, LLC 85 Baldwin Ave Pontiac, MI	5627 Auburn Rd Shelby Twp., MI	520.00 0.00	520.00 520.00
19-0007480 64-14-22-202-002 64-14-22-202-002	GRASS	Repro Pontiac 81 Tregent St ST Pontiac, MI	76 Henderson St Pontiac, MI	235.00 0.00	235.00 235.00
19-0007482 64-14-20-328-004 64-14-20-328-004	GRASS	Sherry Ortega 182 Pingree Ave Pontiac, MI	633 Coldspring Rd Fayetteville, PA	235.00 0.00	235.00 235.00
19-0007487 64-14-21-354-006 64-14-21-354-006	GRASS	Nghbrhd Real Est Inite 166 Beach St Pontiac, MI	701 Woodward Hts Ste 1 Ferndale, MI	235.00 0.00	235.00 235.00
19-0007489 64-14-22-105-023 64-14-22-105-023	GRASS	Herd, Jason 877 Melrose Ave Pontiac, MI	96 Oakhill Street Pontiac, MI	235.00 0.00	235.00 235.00
19-0007491 64-14-22-106-016 64-14-22-106-016	GRASS	Delosangeles, Victor 221 Robinwood St Pontiac, MI	16372 Lower Harbor Rd Brookings, OR	235.00 0.00	235.00 235.00
19-0007492 64-14-22-352-023 64-14-22-352-023	GRASS	Stella, James 328 W Huron St Pontiac, MI	429 Wishbone Dr Blomfield Hills, MI	235.00 0.00	235.00 235.00

09/29/2020
01:56 PM

Billing Register for City of Pontiac
Population: All Records

Page: 4/9
City: Pontiac

Invoices # Customer # Parcel #	Srvc Code	Owner Prop. Address	Mailing Address	Amt. Chg. Fmts/Credits	Amt. Billed Amt. Due
19-0007493 64-14-29-254-006 64-14-29-254-006	GRASS	Evans Gladwin Dale W Huron Pontiac, MI	839 W Huron Pontiac, MI	235.00 0.00	235.00 235.00
19-0007494 64-14-30-426-030 64-14-30-426-030	GRASS	Searles, Brian 196 Liberty St Pontiac, MI	196 Liberty St Pontiac, MI	235.00 0.00	235.00 235.00
19-0007495 64-14-30-480-003 64-14-30-480-003	GRASS	Amanda Yelder 555 W Huron St PONTIAC, MI	4320 N 164th Ave Goodyear, AZ	235.00 0.00	235.00 235.00
19-0007496 64-14-31-252-001 64-14-31-252-001	GRASS	Nguyen, Mark 221 Chippewa Rd Pontiac, MI	1935 Juniper Dr Little Elm, TX	235.00 0.00	235.00 235.00
19-0007497 64-14-29-408-018 64-14-29-408-018	GRASS	Detroit SMSA Ltd Partn W Huron Pontiac, MI	909 Chestnut Street Saint Louis, MO	510.00 0.00	510.00 510.00
19-0007541 64-19-05-206-026 64-19-05-206-026	GRASS	Special Touch Learning Colorado Pontiac, MI	1208 Woodlake Ln Pontiac, MI	235.00 0.00	235.00 235.00
19-0007544 64-19-05-232-033 64-19-05-232-033	GRASS	Wright, Beatrice L Arthur Pontiac, MI	1265 Oaklawn Dr Pontiac, MI	235.00 0.00	235.00 235.00
19-0007545 64-19-05-234-021 64-19-05-234-021	GRASS	Special Touch Learning 554 Luther Ave Pontiac, MI	1208 Woodlake Ln Pontiac, MI	235.00 0.00	235.00 235.00
19-0007547 64-19-05-275-028 64-19-05-275-028	GRASS	JC Transporting Inc 473 Ditmar Ave Pontiac, MI	2510 S Telegraph Rd St Bloomfield Hills, MI	235.00 0.00	235.00 235.00
19-0007548 64-19-05-226-001 64-19-05-226-001	GRASS	Special Touch Learning 321 South W Blvd Pontiac, MI	1208 Woodlake Ln Pontiac, MI	235.00 0.00	235.00 235.00
19-0007549 64-19-04-107-023 64-19-04-107-023	GRASS	Bell, William 502 Bloomfield Ave Pontiac, MI	502 Bloomfield Ave Pontiac, MI	235.00 0.00	235.00 235.00
19-0007551 64-14-32-493-021 64-14-32-493-021	GRASS	Special Touch Learning 328 W Wilson Ave Pontiac, MI	1208 Woodlake Ln Pontiac, MI	235.00 0.00	235.00 235.00
19-0007552 64-14-32-210-047 64-14-32-210-047	GRASS	Sirlin, Ralph J 124 Jackson ,	1685 Winthrop Ln Birmingham, MI	235.00 0.00	235.00 235.00
19-0007555 64-14-32-211-041 64-14-32-211-041	GRASS	Grand Trunk Western RR Wesson ,	2300 Liversolls, Ste 92 Troy, MI	235.00 0.00	235.00 235.00
19-0007556 64-14-32-232-002 64-14-32-232-002	GRASS	Consumers Energy Compa 55 Wesson St Pontiac, MI	1 Energy Plaza Dr Jackson, MI	370.00 0.00	370.00 370.00
19-0007557 64-14-32-478-039 64-14-32-478-039	GRASS	Special Touch Learning 248 Hughes Ave Pontiac, MI	1208 Woodlake Ln Pontiac, MI	165.00 0.00	165.00 165.00
19-0007558 64-14-32-478-016 64-14-32-478-016	GRASS	Special Touch Learning 248 Hughes Ave Pontiac, MI	1208 Hughes Ave Pontiac, MI	165.00 0.00	165.00 165.00
19-0007560 64-14-32-476-035 64-14-32-476-035	GRASS	Special Touch Learning 255 Harrison Ave Pontiac, MI	1208 Woodlake Ln Pontiac, MI	165.00 0.00	165.00 165.00
19-0007561 64-14-32-478-020 64-14-32-478-020	GRASS	Miguel A Diaz Leon Cha 247 Harrison Ave Pontiac, MI	271 Michigan Ave Pontiac, MI	235.00 0.00	235.00 235.00
19-0007562 64-14-32-428-001 64-14-32-428-001	GRASS	HRJ Management Group, 238 Rapid St Pontiac, MI	12745 S Saginaw St Ste Grand Blanc, MI	235.00 0.00	235.00 235.00

09/29/2020
01:56 PM

Billing Register for City of Pontiac
Population: All Records

Page: 5/9
09: Pontiac

Invoice # Customer # Parcel #	Srvs Code	Owner Prop. Address	Mailing Address	Amo. Chg. Emts/Crdts	Amo. Billed Amo. Due
19-0007563 64-14-32-427-519 64-14-32-427-519	GRASS	Hopkins, Russell Rapid Pontiac, MI	64 W Tennyson Ave Pontiac, MI	235.00 0.00	235.00 235.00
19-0007566 64-19-05-252-021 64-19-05-252-021	GRASS	Jackson, Zerlina Arthur Pontiac, MI	270 Cherokee Rd Pontiac, MI	235.00 0.00	235.00 235.00
19-0007567 64-14-33-479-001 64-14-33-479-001	GRASS	Matthews, Mary 406 Irwin Ave Pontiac, MI	406 Irwin Ave Pontiac, MI	235.00 0.00	235.00 235.00
19-0007568 64-14-33-479-002 64-14-33-479-002	GRASS	Crown Enterprises Inc 420 Irwin Ave Pontiac, MI	PO Box 869 Warren, MI	235.00 0.00	235.00 235.00
19-0007569 64-14-33-476-021 64-14-33-476-021	GRASS	Lacewell Group 478 Midway Ave Pontiac, MI	23 Oak Creek Ln Pontiac, MI	235.00 0.00	235.00 235.00
19-0007571 64-14-15-426-337 64-14-15-426-337	GRASS	Donaldson Jr., Calvin 1028 Williamson Cir Pontiac, MI	231 Mattie Lu Auburn Hills, MI	165.00 0.00	165.00 165.00
19-0007572 64-14-15-426-352 64-14-15-426-352	GRASS	Donaldson Jr., Calvin 1048 Williamson Cir Pontiac, MI	231 Mattie Lu Auburn Hills, MI	165.00 0.00	165.00 165.00
19-0007573 64-14-15-426-351 64-14-15-426-351	GRASS	Donaldson Jr., Calvin 1052 Williamson Cir Pontiac, MI	231 Mattie Lu Auburn Hills, MI	165.00 0.00	165.00 165.00
19-0007574 64-14-15-426-350 64-14-15-426-350	GRASS	Donaldson Jr., Calvin 1056 Williamson Cir Pontiac, MI	231 Mattie Lu Dr Auburn Hills, MI	165.00 0.00	165.00 165.00
19-0007575 64-14-15-427-017 64-14-15-427-017	GRASS	Donaldson Jr., Calvin 1072 Williamson Cir Pontiac, MI	231 Mattie Lu Auburn Hills, MI	165.00 0.00	165.00 165.00
19-0007576 64-14-15-427-020 64-14-15-427-020	GRASS	Donaldson Jr., Calvin 1082 Williamson Cir Pontiac, MI	231 Mattie Lu Auburn Hills, MI	165.00 0.00	165.00 165.00
19-0007577 64-14-15-427-021 64-14-15-427-021	GRASS	Donaldson Jr., Calvin 1097 Williamson Cir Pontiac, MI	2310 Mattie Lu Auburn Hills, MI	165.00 0.00	165.00 165.00
19-0007578 64-14-15-427-026 64-14-15-427-026	GRASS	Donaldson, Calvin 1107 Williamson Cir Pontiac, MI	2310 Mattie Lu Auburn Hills, MI	165.00 0.00	165.00 165.00
19-0007579 64-14-15-426-333 64-14-15-426-333	GRASS	Donaldson Jr., Calvin 1110 Williamson Cir Pontiac, MI	2310 Mattie Lu Auburn Hills, MI	165.00 0.00	165.00 165.00
19-0007580 64-14-15-427-027 64-14-15-427-027	GRASS	Donaldson Jr., Calvin 1111 Williamson Cir Pontiac, MI	2310 Mattie Lu Auburn Hills, MI	165.00 0.00	165.00 165.00
19-0007581 64-14-15-427-028 64-14-15-427-028	GRASS	Donaldson Jr., Calvin 1115 Williamson Cir Pontiac, MI	2310 Mattie Lu Auburn Hills, MI	165.00 0.00	165.00 165.00
19-0007582 64-14-15-427-007 64-14-15-427-007	GRASS	Donaldson Jr., Calvin 1117 Carpenter Dr Pontiac, MI	2310 Mattie Lu Auburn Hills, MI	165.00 0.00	165.00 165.00
19-0007583 64-14-15-427-029 64-14-15-427-029	GRASS	Donaldson Jr., Calvin 1119 Williamson Cir Pontiac, MI	2310 Mattie Lu Auburn Hills, MI	165.00 0.00	165.00 165.00
19-0007584 64-14-15-427-030 64-14-15-427-030	GRASS	Donaldson Jr., Calvin 1123 Williamson Cir Pontiac, MI	2310 Mattie Lu Auburn Hills, MI	165.00 0.00	165.00 165.00
19-0007585 64-14-15-427-004 64-14-15-427-004	GRASS	Donaldson Jr., Calvin 1124 Carpenter Dr Pontiac, MI	231 Mattie Lu Auburn Hills, MI	165.00 0.00	165.00 165.00

08/29/2020
01:56 PM

Billing Register for City of Pontiac
Population: All Records

Page: 6/8
001 Pontiac

Invoices # Customer # Parcel #	Srvr Code	Owner Prop. Address	Mailing Address	Amt. Chg. Emts/Crds	Amt. Billed Amt. Due
18-0007586 64-14-18-427-009 64-14-18-427-009	GRASS	Jodaves LLC 1125 Carpenter Dr Pontiac, MI	850 Lakewood Dr Rochester, MI	165.00 0.00	165.00 165.00
18-0007587 64-14-18-427-031 64-14-18-427-031	GRASS	Donalson Jr, Calvin 1127 Williamsor Cir Pontiac, MI	2310 Mattie Lu Auburn Hills, MI	165.00 0.00	165.00 165.00
18-0007588 64-14-18-427-010 64-14-18-427-010	GRASS	Jodaves LLC 1129 Carpenter Dr Pontiac, MI	850 Lakewood Dr Rochester, MI	165.00 0.00	165.00 165.00
18-0007589 64-14-18-427-002 64-14-18-427-002	GRASS	Donalson Jr, Calvin 1132 Carpenter Dr DR Pontiac, MI	2310 Mattie Lu Dr Auburn Hills, MI	165.00 0.00	165.00 165.00
18-0007590 64-14-18-427-011 64-14-18-427-011	GRASS	Jodaves LLC 1133 Carpenter Dr Pontiac, MI	850 Lakewood Dr Rochester, MI	165.00 0.00	165.00 165.00
18-0007591 64-14-17-130-006 64-14-17-130-006	GRASS	Sheffield Holding LLC W Sheffield Pontiac, MI	PO Box 531745 Livonia, MI	310.00 0.00	310.00 310.00
18-0007592 64-14-17-177-001 64-14-17-177-001	GRASS	Sherman William II 69 W Hopkins Ave Pontiac, MI	390 W Hopkins Ave, Apt Pontiac, MI	235.00 0.00	235.00 235.00
18-0007594 64-14-17-333-028 64-14-17-333-028	GRASS	Young, Heaven Saldwin Pontiac, MI	6990 Hatchery Rd Waterford, MI	235.00 0.00	235.00 235.00
18-0007594 64-14-18-481-027 64-14-18-481-027	GRASS	Bank of America 277 W Kenneth Rd Pontiac, MI	2375 N Glenville Dr Richardson, TX	370.00 0.00	370.00 370.00
18-0007597 64-14-28-458-037 64-14-28-458-037	GRASS	Community Housing Netw S Sanford Pontiac, MI	570 Kirts Blvd Troy, MI	235.00 0.00	235.00 235.00
18-0007598 64-14-28-460-010 64-14-28-460-010	GRASS	Shelton, Dawn 77 S Sanford St Pontiac, MI	PO Box 431955 Pontiac, MI	235.00 0.00	235.00 235.00
18-0007601 64-14-16-405-024 64-14-16-405-024	GRASS	Cobb, Clayton 671 4th Ave Pontiac, MI	214 S Marriac St Pontiac, MI	165.00 0.00	165.00 165.00
18-0007603 64-14-21-328-014 64-14-21-328-014	GRASS	Gelonska, Diane E 260 Nelson ST Pontiac, MI	260 Nelson Street Pontiac, MI	235.00 0.00	235.00 235.00
18-0007604 64-14-18-378-032 64-14-18-378-032	GRASS	Esparrza Corrao, Kedlyn 853 Kettering Ave Pontiac, MI	953 Kettering Ave Pontiac, MI	235.00 0.00	235.00 235.00
18-0007605 64-14-27-306-014 64-14-27-306-014	GRASS	United Social Effort F 31 N Astor St Pontiac, MI	15565 Northland Ex E S Southfield, MI	900.00 0.00	900.00 900.00
18-0007607 64-14-16-108-011 64-14-16-108-011	GRASS	Harrington, Steven 375 E Sheffield AVE Pontiac, MI	375 E Sheffield Ave Pontiac, MI	235.00 0.00	235.00 235.00
18-0007608 64-14-21-379-005 64-14-21-379-009	GRASS	Smith, Patrick L 464 Harper St Pontiac, MI	477 Harper St Pontiac, MI	235.00 0.00	235.00 235.00
18-0007610 64-19-05-252-033 64-19-05-252-032	GRASS	Wright, Beatrice L Arthur Pontiac, MI	1268 Oaklawn Dr Pontiac, MI	235.00 0.00	235.00 235.00
18-0007611 64-19-05-252-031 64-19-05-252-031	GRASS	Special Touch Learning 550 Arthur Ave Pontiac, MI	151 Lafayette St Apt 1 Pontiac, MI	235.00 0.00	235.00 235.00
18-0007612 64-14-21-428-032 64-14-21-428-032	GRASS	Slavin III, Robert 701 Desota Pl Pontiac, MI	1135 Audubon Dr Waterford, MI	235.00 0.00	235.00 235.00

05/29/2020
01:56 PM

Billing Register for City of Pontiac
Population: All Records

Page: 7/9
001 Pontiac

Invoices # Customer # Parcel #	Srvc Code	Owner Prop. Address	Mailing Address	Amt. Chg. Fmts/Crdts	Amt. Billed Amt. Due
15-0007613 64-14-22-110-030 64-14-22-110-030	GRASS	Brickland, LLC 755 Melrose Ave Pontiac, MI	26644 Farmbrook Villa Southfield, MI	235.00 0.00	235.00 235.00
15-0007614 64-14-27-330-023 64-14-27-330-023	GRASS	SK RE Ventures LLC 811 E Pike St Pontiac, MI	23075 Laurel Valley St Southfield, MI	235.00 0.00	235.00 235.00
15-0007615 64-14-28-102-008 64-14-28-102-008	GRASS	Hercoot Pontiac 42 Gingell Ct Pontiac, MI	76 Henderson Street Pontiac, MI	235.00 0.00	235.00 235.00
15-0007616 64-14-28-103-009 64-14-28-103-009	GRASS	Hercoot Pontiac 38 Gingell Ct Pontiac, MI	76 Henderson St Pontiac, MI	235.00 0.00	235.00 235.00
15-0007617 64-14-32-127-010 64-14-32-127-010	GRASS	Lawrence Swart Jr. 270 Orchard Lake Rd Pontiac, MI	1630 Ledbury Dr Bloomfield Hills, MI	235.00 0.00	235.00 235.00
15-0007619 64-14-33-433-002 64-14-33-433-002	GRASS	Albritton, James E 500 Raeburn St Pontiac, MI	500 Raeburn St PO Box Pontiac, MI	235.00 0.00	235.00 235.00
15-0007620 64-14-37-327-042 64-14-37-327-042	GRASS	Telisky, Timothy F 89 W Longfellow Ave Pontiac, MI	89 W Longfellow Ave Pontiac, MI	235.00 0.00	235.00 235.00
15-0007621 64-14-33-478-030 64-14-33-478-030	GRASS	Dian Leon Chavez, Migu 435 Irwin Ave Pontiac, MI	271 Michigan Ave Pontiac, MI	370.00 0.00	370.00 370.00
15-0007622 64-14-32-156-008 64-14-32-156-008	GRASS	Fulbright, Harry 11 Lake St Pontiac, MI	PO Box 421956 Pontiac, MI	235.00 0.00	235.00 235.00
15-0007624 64-14-27-353-014 64-14-27-353-014	GRASS	Lease, Paul W 678 Rosewood Fl Pontiac, MI	116 S Roslyn Rd Waterford, MI	235.00 0.00	235.00 235.00
15-0007625 64-14-31-153-001 64-14-31-153-001	GRASS	Nolan Group Developmen Ruth Pontiac, MI	4135 Pomona Colony Bloomfield Hills, MI	235.00 0.00	235.00 235.00
15-0007625 64-14-31-153-002 64-14-31-153-002	GRASS	Nolan Group Developmen 241 S Telegraph Rd Pontiac, MI	4135 Pomona Colony Bloomfield Hills, MI	235.00 0.00	235.00 235.00
15-0007632 64-19-05-278-035 64-19-05-278-035	GRASS	Robinson, Ruby Y 452 Ditmar Ave Pontiac, MI	22 Franklin Rd Pontiac, MI	235.00 0.00	235.00 235.00
15-0007633 64-19-05-278-030 64-19-05-278-030	GRASS	JC Transporting Inc Luther Pontiac, MI	2510 W Telegraph Rd St Bloomfield Hills, MI	235.00 0.00	235.00 235.00
15-0007634 64-19-04-105-001 64-19-04-105-001	GRASS	Maccreana D Ballford 453 Franklin Rd Pontiac, MI	161 N Anzor Street Pontiac, MI	165.00 0.00	165.00 165.00
15-0007635 64-19-04-105-002 64-19-04-105-002	GRASS	Carson, Arno 459 Franklin Rd Pontiac, MI	114 Hibbard Ct 5 Pontiac, MI	165.00 0.00	165.00 165.00
15-0007637 64-14-20-229-013 64-14-20-229-013	GRASS	Frausto, Yadira Nieves 37 LaGrande Ave Pontiac, MI	37 LaGrande Ave Pontiac, MI	235.00 0.00	235.00 235.00
15-0007638 64-14-32-127-012 64-14-32-127-012	GRASS	258 Orchard Lake Rd 258 Orchard Lake Rd Pontiac, MI	55 E Long Lake Rd Pontiac, MI	235.00 0.00	235.00 235.00
15-0007639 64-14-32-430-026 64-14-32-430-026	GRASS	Special Touch Learning 196 Rockwell AVE Pontiac, MI	151 Lafayette St Apt 1 Pontiac, MI	235.00 0.00	235.00 235.00
15-0007642 64-14-25-408-018 64-14-25-408-018	GRASS	Detroit SMER Ltd Parth W Huron Pontiac, MI	909 Chestnut Street Saint Louis, MO	235.00 0.00	235.00 235.00

Invoices # Customer # Parcel #	Srvc Code	Owner Prop. Address	Mailing Address	Amt. Chg. Emts/Crdts	Amt. Billed Amt. Due
19-0007843 64-14-32-475-002 64-14-32-475-002	GRASS	Crown Enterprises Inc 415 Irwin Ave Pontiac, MI	PO Box 269 Warren, MI	235.00 0.00	235.00 235.00
19-0007844 64-14-32-475-001 64-14-32-475-001	GRASS	Matthews, Mary 406 Irwin Ave Pontiac, MI	406 Irwin Ave Pontiac, MI	235.00 0.00	235.00 235.00
19-0007846 64-14-29-403-017 64-14-29-403-017	GRASS	Detroit SMOA Ltd Partn Woodward Pontiac, MI	1010 Pine St # 9E-L-01 Saint Louis, MO	235.00 0.00	235.00 235.00
19-0007847 64-14-32-233-011 64-14-32-233-011	GRASS	Chambers, Nathan Woodward Pontiac, MI	987 Bristol Dr Rochester Hills, MI	235.00 0.00	235.00 235.00
20-0007896 64-14-15-426-033 64-14-15-426-033	GRASS	Donalson Jr, Calvin 1110 Williamson Cir Pontiac, MI	2310 Mattie Lu Auburn Hills, MI	235.00 0.00	235.00 235.00
20-0007897 64-14-15-426-052 64-14-15-426-052	GRASS	Donalson Jr, Calvin 1056 Williamson Cir Pontiac, MI	231 Mattie Lu Dr Auburn Hills, MI	235.00 0.00	235.00 235.00
20-0007898 64-14-15-426-051 64-14-15-426-051	GRASS	Donalson Jr, Calvin 1052 Williamson Cir Pontiac, MI	231 Mattie Lu Auburn Hills, MI	235.00 0.00	235.00 235.00
20-0007899 64-14-15-426-057 64-14-15-426-057	GRASS	Donalson Jr., Calvin 1028 Williamson Cir Pontiac, MI	231 Mattie Lu Auburn Hills, MI	235.00 0.00	235.00 235.00
20-0007900 64-14-15-426-052 64-14-15-426-052	GRASS	Donalson Jr, Calvin 1048 Williamson Cir Pontiac, MI	231 Mattie Lu Auburn Hills, MI	235.00 0.00	235.00 235.00
20-0007901 64-14-15-427-002 64-14-15-427-002	GRASS	Donalson Jr, Calvin 1122 Carpenter Dr DR Pontiac, MI	2310 Mattie Lu Dr Auburn Hills, MI	235.00 0.00	235.00 235.00
20-0007902 64-14-15-427-004 64-14-15-427-004	GRASS	Donalson Jr, Calvin 1124 Carpenter Dr Pontiac, MI	231 Mattie Lu Auburn Hills, MI	235.00 0.00	235.00 235.00
20-0007903 64-14-15-427-007 64-14-15-427-007	GRASS	Donalson Jr, Calvin 1117 Carpenter Dr Pontiac, MI	2310 Mattie Lu Auburn Hills, MI	235.00 0.00	235.00 235.00
20-0007904 64-14-15-427-017 64-14-15-427-017	GRASS	Donalson Jr, Calvin 1073 Williamson Cir Pontiac, MI	231 Mattie Lu Auburn Hills, MI	235.00 0.00	235.00 235.00
20-0007905 64-14-15-427-020 64-14-15-427-020	GRASS	Donalson Jr, Calvin 1063 Williamson Cir Pontiac, MI	231 Mattie Lu Auburn Hills, MI	235.00 0.00	235.00 235.00
20-0007906 64-14-15-427-028 64-14-15-427-028	GRASS	Donalson, Calvin 1107 Williamson Cir Pontiac, MI	2310 Mattie Lu Auburn Hills, MI	235.00 0.00	235.00 235.00
20-0007907 64-14-15-427-027 64-14-15-427-027	GRASS	Donalson Jr, Calvin 1111 Williamson Cir Pontiac, MI	2310 Mattie Lu Auburn Hills, MI	235.00 0.00	235.00 235.00
20-0007908 64-14-15-427-028 64-14-15-427-028	GRASS	Donalson Jr, Calvin 1115 Williamson Cir Pontiac, MI	2310 Mattie Lu Auburn Hills, MI	235.00 0.00	235.00 235.00
20-0007909 64-14-15-427-029 64-14-15-427-029	GRASS	Donalson Jr, Calvin 1119 Williamson Cir Pontiac, MI	2310 Mattie Lu Auburn Hills, MI	235.00 0.00	235.00 235.00
20-0007910 64-14-15-427-030 64-14-15-427-030	GRASS	Donalson Jr, Calvin 1123 Williamson Cir Pontiac, MI	2310 Mattie Lu Auburn Hills, MI	235.00 0.00	235.00 235.00
20-0007911 64-14-15-427-031 64-14-15-427-031	GRASS	Donalson Jr, Calvin 1127 Williamson Cir Pontiac, MI	2310 Mattie Lu Auburn Hills, MI	235.00 0.00	235.00 235.00

09/19/2020
01:56 PM

Billing Register for City of Pontiac
Population: All Records

Page: 9/9
City of Pontiac

Invoices # Customer # Parcel #	Srvc Code	Owner Prop. Address	Mailing Address	Amt. Chg. Fmts/Crdts	Amt. Billed Amt. Due
20-0007512	GRASS	Donalson Jr, Calvin	2310 Matzie Ln	235.00	235.00
64-14-15-427-021		1087 Williamson Cir	Auburn Hills, MI	0.00	235.00
64-14-15-427-021		Pontiac, MI			
Billing Items Summary				Item Amt.	Item Bal.
WEEDS Totals				38,705.00	38,705.00
=====					
TOTALS				38,705.00	38,705.00
				0.00	38,705.00
				0.00	38,705.00

09/28/2020
12:18 PM

Tax Assignment Report for City of Pontiac

Page: 1/3
DB: Pontiac

Trial Run

Cust ID Invoice #	Customer Name Post Date	Billing Item	Item Code	Balance	Additional	Tot Transferred
64-14-07-480-010 19-0007342	Ramseyer, Erik 09/24/2019	DemoOC	DemoOC	1950.00 1950.00	0.00 0.00	1950.00 1950.00
64-14-21-405-006 19-0007341	AAronco Management Co. Inc. 09/24/2019	DemoOC	DemoOC	450.00 450.00	0.00 0.00	450.00 450.00
64-19-05-226-004 19-0007343	Smart Living Solutions 09/24/2019	DemoOC	DemoOC	1250.00 1250.00	0.00 0.00	1250.00 1250.00
----->	Totals DemoOC			3,650.00		
----->	Grand Total			3,650.00		

09/28/2020
12:18 PM

Tax Assignment Report for City of Pontiac

Page: 3/3
DB: Pontiac

Trial Run

Cust ID	Customer Name		Item Code	Balance	Additional	Tot Transferred
Invoice #	Post Date	Billing Item				

Warnings	Message / Details
----------	----------------------

Invoice '20-0007851' skipped.
Invoice '20-0007851' must be journalized before transferring to Tax.

Trial Run

Cust ID Invoice #	Customer Name Post Date	Billing Item	Item Code	Balance	Additional	Tot Transferred
64-14-15-378-032 19-0007604	Esparza Corzo, Kedlyn Vidu 12/23/2019	WEEDS	GRASS	235.00 235.00	0.00 0.00	235.00 235.00
64-14-15-426-033 19-0007579 20-0007896	Donalson Jr, Calvin 12/23/2019 06/30/2020	WEEDS WEEDS	GRASS	400.00 165.00 235.00	0.00 0.00 0.00	400.00 165.00 235.00
64-14-15-426-050 20-0007897 19-0007574	Donaldson Jr, Calvin 06/30/2020 12/23/2019	WEEDS WEEDS	GRASS	400.00 235.00 165.00	0.00 0.00 0.00	400.00 235.00 165.00
64-14-15-426-051 19-0007573 20-0007898	Donalson Jr, Calvin 12/23/2019 06/30/2020	WEEDS WEEDS	GRASS	400.00 165.00 235.00	0.00 0.00 0.00	400.00 165.00 235.00
64-14-15-426-052 20-0007900 19-0007572	Donalson Jr, Calvin 06/30/2020 12/23/2019	WEEDS WEEDS	GRASS	400.00 235.00 165.00	0.00 0.00 0.00	400.00 235.00 165.00
64-14-15-426-057 19-0007571 20-0007899	Donaldson Jr., Calvin 12/23/2019 06/30/2020	WEEDS WEEDS	GRASS	400.00 165.00 235.00	0.00 0.00 0.00	400.00 165.00 235.00
64-14-15-427-002 19-0007589 20-0007901	Donalson Jr, Calvin 12/23/2019 06/30/2020	WEEDS WEEDS	GRASS	400.00 165.00 235.00	0.00 0.00 0.00	400.00 165.00 235.00
64-14-15-427-004 19-0007585 20-0007902	Donalson Jr, Calvin 12/23/2019 06/30/2020	WEEDS WEEDS	GRASS	400.00 165.00 235.00	0.00 0.00 0.00	400.00 165.00 235.00
64-14-15-427-007 20-0007903 19-0007582	Donalson Jr, Calvin 06/30/2020 12/23/2019	WEEDS WEEDS	GRASS	400.00 235.00 165.00	0.00 0.00 0.00	400.00 235.00 165.00
64-14-15-427-009 19-0007586	Jodaves LLC 12/23/2019	WEEDS	GRASS	165.00 165.00	0.00 0.00	165.00 165.00
64-14-15-427-010 19-0007588	Jodaves LLC 12/23/2019	WEEDS	GRASS	165.00 165.00	0.00 0.00	165.00 165.00
64-14-15-427-011 19-0007590	Jodaves LLC 12/23/2019	WEEDS	GRASS	165.00 165.00	0.00 0.00	165.00 165.00
64-14-15-427-017	Donalson Jr, Calvin		GRASS	400.00	0.00	400.00

09/29/2020
01:48 PM

Tax Assignment Report for City of Pontiac

Page: 2/18
DB: Pontiac

			Trial Run		
Cust ID	Customer Name	Item Code	Balance	Additional	Tot Transferred
Invoice #	Post Date	Billing Item			
19-0007575	12/23/2019	WEEDS	165.00	0.00	165.00
20-0007904	06/30/2020	WEEDS	235.00	0.00	235.00
64-14-15-427-020	Donlason Jr, Calvin	GRASS	400.00	0.00	400.00
20-0007905	06/30/2020	WEEDS	235.00	0.00	235.00
19-0007576	12/23/2019	WEEDS	165.00	0.00	165.00
64-14-15-427-021	Donalson Jr, Calvin	GRASS	400.00	0.00	400.00
19-0007577	12/23/2019	WEEDS	165.00	0.00	165.00
20-0007912	06/30/2020	WEEDS	235.00	0.00	235.00
64-14-15-427-026	Donalson, Calvin	GRASS	400.00	0.00	400.00
20-0007906	07/15/2020	WEEDS	235.00	0.00	235.00
19-0007578	12/23/2019	WEEDS	165.00	0.00	165.00
64-14-15-427-027	Donaldson Jr, Calvin	GRASS	400.00	0.00	400.00
20-0007907	06/30/2020	WEEDS	235.00	0.00	235.00
19-0007580	12/23/2019	WEEDS	165.00	0.00	165.00
64-14-15-427-028	Donalson Jr, Calvin	GRASS	400.00	0.00	400.00
19-0007581	12/23/2019	WEEDS	165.00	0.00	165.00
20-0007908	06/30/2020	WEEDS	235.00	0.00	235.00
64-14-15-427-029	Donalson Jr, Calvin	GRASS	400.00	0.00	400.00
19-0007583	12/23/2019	WEEDS	165.00	0.00	165.00
20-0007909	06/30/2020	WEEDS	235.00	0.00	235.00
64-14-15-427-030	Donalson Jr, Calvin	GRASS	400.00	0.00	400.00
20-0007910	06/30/2020	WEEDS	235.00	0.00	235.00
19-0007584	12/23/2019	WEEDS	165.00	0.00	165.00
64-14-15-427-031	Donalson Jr, Calvin	GRASS	400.00	0.00	400.00
19-0007587	12/23/2019	WEEDS	165.00	0.00	165.00
20-0007911	06/30/2020	WEEDS	235.00	0.00	235.00
64-14-16-105-011	Harrington, Steven	GRASS	235.00	0.00	235.00
19-0007607	12/23/2019	WEEDS	235.00	0.00	235.00
64-14-16-405-024	Cobb, Clayton	GRASS	165.00	0.00	165.00
19-0007602	12/23/2019	WEEDS	165.00	0.00	165.00
64-14-16-405-025	Valdez, Kristiana	GRASS	235.00	0.00	235.00
19-0007452	11/05/2019	WEEDS	235.00	0.00	235.00
64-14-16-426-026	Belcher, Jamey	GRASS	235.00	0.00	235.00

Trial Run

Cust ID Invoice #	Customer Name Post Date	Billing Item	Item Code	Balance	Additional	Tot Transferred
19-0007377	10/04/2019	WEEDS		235.00	0.00	235.00
64-14-17-130-006	Sheffield Holding LLC		GRASS	310.00	0.00	310.00
19-0007591	12/23/2019	WEEDS		310.00	0.00	310.00
64-14-17-152-001	BPEB LLC		GRASS	165.00	0.00	165.00
19-0007439	11/05/2019	WEEDS		165.00	0.00	165.00
64-14-17-177-001	Sherman William II		GRASS	235.00	0.00	235.00
19-0007592	12/23/2019	WEEDS		235.00	0.00	235.00
64-14-17-327-042	Telisky, Timothy F		GRASS	235.00	0.00	235.00
19-0007620	12/13/2019	WEEDS		235.00	0.00	235.00
64-14-17-333-028	Young, Heaven		GRASS	605.00	0.00	605.00
19-0007374	10/04/2019	WEEDS		370.00	0.00	370.00
19-0007593	12/23/2019	WEEDS		235.00	0.00	235.00
64-14-18-481-027	Bank of America		GRASS	370.00	0.00	370.00
19-0007594	12/23/2019	WEEDS		370.00	0.00	370.00
64-14-20-107-017	Hogg, Ryan		GRASS	370.00	0.00	370.00
19-0007476	11/05/2019	WEEDS		370.00	0.00	370.00
64-14-20-126-027	Douglas, Shelia		GRASS	235.00	0.00	235.00
19-0007465	11/05/2019	WEEDS		235.00	0.00	235.00
64-14-20-328-004	Sherry Ortega		GRASS	235.00	0.00	235.00
19-0007485	11/06/2019	WEEDS		235.00	0.00	235.00
64-14-20-329-013	Frausto, Yadira Nieves		GRASS	235.00	0.00	235.00
19-0007637	12/16/2019	WEEDS		235.00	0.00	235.00
64-14-21-255-003	E Kennett 618		GRASS	235.00	0.00	235.00
19-0007451	11/05/2019	WEEDS		235.00	0.00	235.00
64-14-21-257-022	US Bank National Association		GRASS	235.00	0.00	235.00
19-0007450	11/05/2019	WEEDS		235.00	0.00	235.00
64-14-21-329-014	Golonska, Diane E		GRASS	470.00	0.00	470.00
19-0007603	12/23/2019	WEEDS		235.00	0.00	235.00
19-0007436	11/05/2019	WEEDS		235.00	0.00	235.00
64-14-21-329-026	Goldman, Ezra N		GRASS	400.00	0.00	400.00
19-0007437	11/05/2019	WEEDS		165.00	0.00	165.00

09/29/2020
01:48 PM

Tax Assignment Report for City of Pontiac

Page: 4/18
DB: Pontiac

		Trial Run				
Cust ID	Customer Name	Item Code	Balance	Additional	Tot Transferred	
Invoice #	Post Date	Billing Item				
19-0007380	10/08/2019	WEEDS	235.00	0.00	235.00	
64-14-21-330-004	SK Pontiac Assets LLC	GRASS	235.00	0.00	235.00	
19-0007466	11/05/2019	WEEDS	235.00	0.00	235.00	
64-14-21-354-006	Nghbrhd Real Est Initiative LLC	GRASS	235.00	0.00	235.00	
19-0007487	11/06/2019	WEEDS	235.00	0.00	235.00	
64-14-21-377-039	Diaz Leon Chavez, Miguel A	GRASS	235.00	0.00	235.00	
19-0007383	10/08/2019	WEEDS	235.00	0.00	235.00	
64-14-21-379-009	Smith, Patrick L	GRASS	235.00	0.00	235.00	
19-0007608	12/23/2019	WEEDS	235.00	0.00	235.00	
64-14-21-426-032	Slowin III, Robert	GRASS	235.00	0.00	235.00	
19-0007612	11/01/2019	WEEDS	235.00	0.00	235.00	
64-14-22-105-023	Herd, Jason	GRASS	235.00	0.00	235.00	
19-0007489	11/06/2019	WEEDS	235.00	0.00	235.00	
64-14-22-108-016	Delosangeles, Victor	GRASS	470.00	0.00	470.00	
19-0007491	11/06/2019	WEEDS	235.00	0.00	235.00	
19-0007378	10/04/2019	WEEDS	235.00	0.00	235.00	
64-14-22-110-030	Brickland, LLC	GRASS	235.00	0.00	235.00	
19-0007613	12/13/2019	WEEDS	235.00	0.00	235.00	
64-14-22-152-032	Gauthier, James F	GRASS	235.00	0.00	235.00	
19-0007448	11/05/2019	WEEDS	235.00	0.00	235.00	
64-14-22-176-006	Clarke, Ana May B	GRASS	235.00	0.00	235.00	
19-0007463	11/05/2019	WEEDS	235.00	0.00	235.00	
64-14-22-302-002	Newman, Bertha	GRASS	370.00	0.00	370.00	
19-0007382	10/08/2019	WEEDS	370.00	0.00	370.00	
64-14-22-376-023	Omicron Alpha Alpha Omega Foundation	GRASS	165.00	0.00	165.00	
19-0007457	11/05/2019	WEEDS	165.00	0.00	165.00	
64-14-22-379-032	Omicron Alpha Alpha Omega Foundtion	GRASS	165.00	0.00	165.00	
19-0007458	11/05/2019	WEEDS	165.00	0.00	165.00	
64-14-22-379-033	Omicron Alpha Alpha Omega Foundation	GRASS	165.00	0.00	165.00	
19-0007459	11/05/2019	WEEDS	165.00	0.00	165.00	

09/29/2020
01:48 PM

Tax Assignment Report for City of Pontiac

Page: 5/18
DB: Pontiac

		Trial Run				
Cust ID	Customer Name	Item Code	Balance	Additional	Tot Transferred	
Invoice #	Post Date	Billing Item				
64-14-22-379-034	Omicron Alpha Alpha Omega Foundation	GRASS	165.00	0.00	165.00	
19-0007460	11/05/2019 WEEDS		165.00	0.00	165.00	
64-14-22-380-032	Omicron Alpha Alpha Omega Foundation	GRASS	165.00	0.00	165.00	
19-0007461	11/05/2019 WEEDS		165.00	0.00	165.00	
64-14-22-380-033	Omicron Alpha Alpha Omega Foundation	GRASS	165.00	0.00	165.00	
19-0007462	11/05/2019 WEEDS		165.00	0.00	165.00	
64-14-22-381-012	Himansha, Patel	GRASS	235.00	0.00	235.00	
19-0007449	11/05/2019 WEEDS		235.00	0.00	235.00	
64-14-22-431-002	Kuerbitz, Scott	GRASS	235.00	0.00	235.00	
19-0007381	10/08/2019 WEEDS		235.00	0.00	235.00	
64-14-22-456-011	Sykes, Barry	GRASS	235.00	0.00	235.00	
19-0007438	11/05/2019 WEEDS		235.00	0.00	235.00	
64-14-27-306-014	United Social Effort Foundation	GRASS	900.00	0.00	900.00	
19-0007605	12/23/2019 WEEDS		900.00	0.00	900.00	
64-14-27-330-023	SK RE Ventures LLC	GRASS	235.00	0.00	235.00	
19-0007614	12/13/2019 WEEDS		235.00	0.00	235.00	
64-14-27-331-003	Martin, Donna	GRASS	235.00	0.00	235.00	
19-0007447	11/05/2019 WEEDS		235.00	0.00	235.00	
64-14-27-353-014	Loase, Paul W	GRASS	235.00	0.00	235.00	
19-0007624	12/16/2019 WEEDS		235.00	0.00	235.00	
64-14-28-103-008	Reroot Pontiac	GRASS	235.00	0.00	235.00	
19-0007615	12/13/2019 WEEDS		235.00	0.00	235.00	
64-14-28-103-009	Reroot Pontiac	GRASS	235.00	0.00	235.00	
19-0007616	12/13/2019 WEEDS		235.00	0.00	235.00	
64-14-28-206-008	Wright, Vince	GRASS	370.00	0.00	370.00	
19-0007475	11/05/2019 WEEDS		370.00	0.00	370.00	
64-14-28-308-001	New Star Investments, Inc.	GRASS	370.00	0.00	370.00	
19-0007470	11/05/2019 WEEDS		370.00	0.00	370.00	
64-14-28-331-010	New Liberty Apostolic Church	GRASS	235.00	0.00	235.00	
19-0007464	11/05/2019 WEEDS		235.00	0.00	235.00	

09/29/2020
01:48 PM

Tax Assignment Report for City of Pontiac

Page: 6/18
DB: Pontiac

		Trial Run				
Cust ID	Customer Name	Item Code	Balance	Additional	Tot Transferred	
Invoice #	Post Date	Billing Item				
64-14-28-335-004	Anthony, Mary E	GRASS	235.00	0.00	235.00	
19-0007468	11/05/2019 WEEDS		235.00	0.00	235.00	
64-14-28-408-013	Abusaad, Kawther Mohd	GRASS	235.00	0.00	235.00	
19-0007444	11/05/2019 WEEDS		235.00	0.00	235.00	
64-14-28-459-037	Community Housing Network Inc	GRASS	235.00	0.00	235.00	
19-0007597	12/23/2019 WEEDS		235.00	0.00	235.00	
64-14-28-460-010	Shelton, Dawn	GRASS	235.00	0.00	235.00	
19-0007598	12/23/2019 WEEDS		235.00	0.00	235.00	
64-14-28-484-026	Martinez, Veronica	GRASS	370.00	0.00	370.00	
19-0007366	10/04/2019 WEEDS		370.00	0.00	370.00	
64-14-29-129-001	Little Bunnys, LLC	GRASS	520.00	0.00	520.00	
19-0007479	11/06/2019 WEEDS		520.00	0.00	520.00	
64-14-29-151-005	Reroot Pontiac	GRASS	235.00	0.00	235.00	
19-0007386	10/08/2019 WEEDS		235.00	0.00	235.00	
64-14-29-202-002	Reroot Pontiac	GRASS	235.00	0.00	235.00	
19-0007480	11/06/2019 WEEDS		235.00	0.00	235.00	
64-14-29-226-004	Boyer, Peter	GRASS	235.00	0.00	235.00	
19-0007369	10/04/2019 WEEDS		235.00	0.00	235.00	
64-14-29-257-012	Elephant Ink LLC	GRASS	370.00	0.00	370.00	
19-0007368	10/04/2019 WEEDS		370.00	0.00	370.00	
64-14-29-352-023	Stella, James	GRASS	235.00	0.00	235.00	
19-0007492	11/06/2019 WEEDS		235.00	0.00	235.00	
64-14-29-354-006	Evans Gladwin Dale	GRASS	235.00	0.00	235.00	
19-0007493	11/06/2019 WEEDS		235.00	0.00	235.00	
64-14-29-402-005	49730 LLC	GRASS	235.00	0.00	235.00	
19-0007473	11/05/2019 WEEDS		235.00	0.00	235.00	
64-14-29-408-017	Detroit SMSA Ltd Partnership	GRASS	235.00	0.00	235.00	
19-0007646	12/16/2019 WEEDS		235.00	0.00	235.00	
64-14-29-408-018	Detroit SMSA Ltd Partnership	GRASS	745.00	0.00	745.00	
19-0007642	12/16/2019 WEEDS		235.00	0.00	235.00	
19-0007497	11/06/2019 WEEDS		510.00	0.00	510.00	

			Trial Run			
Cust ID	Customer Name		Item Code	Balance	Additional	Tot Transferred
Invoice #	Post Date	Billing Item				
64-14-30-330-004	American Estate and Trust		GRASS	235.00	0.00	235.00
19-0007384	10/08/2019	WEEDS		235.00	0.00	235.00
64-14-30-402-013	Brown, Eric		GRASS	235.00	0.00	235.00
19-0007385	10/08/2019	WEEDS		235.00	0.00	235.00
64-14-30-426-030	Searles, Brian		GRASS	235.00	0.00	235.00
19-0007494	11/06/2019	WEEDS		235.00	0.00	235.00
64-14-30-427-018	Miskey, Steven A		GRASS	235.00	0.00	235.00
19-0007387	10/08/2019	WEEDS		235.00	0.00	235.00
64-14-30-480-003	Amanda Yelder		GRASS	235.00	0.00	235.00
19-0007495	11/06/2019	WEEDS		235.00	0.00	235.00
64-14-31-153-001	Nolan Group Development LLC		GRASS	235.00	0.00	235.00
19-0007628	12/16/2019	WEEDS		235.00	0.00	235.00
64-14-31-153-002	Nolan Group Development LLC		GRASS	235.00	0.00	235.00
19-0007629	12/16/2019	WEEDS		235.00	0.00	235.00
64-14-31-252-001	Nguyen, Mark		GRASS	235.00	0.00	235.00
19-0007496	11/06/2019	WEEDS		235.00	0.00	235.00
64-14-32-127-010	Lawrence Swart Jr.		GRASS	235.00	0.00	235.00
19-0007617	12/13/2019	WEEDS		235.00	0.00	235.00
64-14-32-127-012	258 Orchard Lake Rd		GRASS	235.00	0.00	235.00
19-0007638	12/16/2019	WEEDS		235.00	0.00	235.00
64-14-32-156-008	Fulbright, Harry		GRASS	235.00	0.00	235.00
19-0007622	12/13/2019	WEEDS		235.00	0.00	235.00
64-14-32-210-047	Sirlin, Ralph J		GRASS	235.00	0.00	235.00
19-0007552	12/23/2019	WEEDS		235.00	0.00	235.00
64-14-32-211-041	Grand Trunk Western RR		GRASS	235.00	0.00	235.00
19-0007555	12/23/2019	WEEDS		235.00	0.00	235.00
64-14-32-232-002	Consumers Energy Company		GRASS	370.00	0.00	370.00
19-0007556	12/23/2019	WEEDS		370.00	0.00	370.00
64-14-32-233-011	Chambers, Nathan		GRASS	235.00	0.00	235.00
19-0007647	12/16/2019	WEEDS		235.00	0.00	235.00

		Trial Run				
Cust ID	Customer Name	Item Code	Balance	Additional	Tot Transferred	
Invoice #	Post Date Billing Item					
64-14-32-427-019	Hopkins, Russell	GRASS	235.00	0.00	235.00	
19-0007563	12/23/2019 WEEDS		235.00	0.00	235.00	
64-14-32-428-001	HRJ Management Group, LLC	GRASS	235.00	0.00	235.00	
19-0007562	12/23/2019 WEEDS		235.00	0.00	235.00	
64-14-32-430-026	Special Touch Learning Center	GRASS	235.00	0.00	235.00	
19-0007639	12/16/2019 WEEDS		235.00	0.00	235.00	
64-14-32-433-021	Special Touch Learning Center	GRASS	235.00	0.00	235.00	
19-0007551	12/23/2019 WEEDS		235.00	0.00	235.00	
64-14-32-476-035	Special Touch Learning Center	GRASS	165.00	0.00	165.00	
19-0007560	12/23/2019 WEEDS		165.00	0.00	165.00	
64-14-32-478-020	Miguel A Diaz Leon Chavez	GRASS	235.00	0.00	235.00	
19-0007561	12/23/2019 WEEDS		235.00	0.00	235.00	
64-14-32-478-039	Mary J Faulkner College	GRASS	165.00	0.00	165.00	
19-0007557	12/23/2019 WEEDS		165.00	0.00	165.00	
64-14-32-479-016	Mary J Faulkner College	GRASS	165.00	0.00	165.00	
19-0007558	12/23/2019 WEEDS		165.00	0.00	165.00	
64-14-33-153-006	Tate, Timothy	GRASS	235.00	0.00	235.00	
19-0007367	10/04/2019 WEEDS		235.00	0.00	235.00	
64-14-33-156-002	Grand Trunk Western RR	GRASS	370.00	0.00	370.00	
19-0007453	11/05/2019 WEEDS		370.00	0.00	370.00	
64-14-33-185-001	Victorious Christian Life Church	GRASS	505.00	0.00	505.00	
19-0007469	11/05/2019 WEEDS		505.00	0.00	505.00	
64-14-33-210-043	Gilmore, Brian	GRASS	235.00	0.00	235.00	
19-0007364	10/04/2019 WEEDS		235.00	0.00	235.00	
64-14-33-233-018	Black, Alonzo D	GRASS	235.00	0.00	235.00	
19-0007365	10/04/2019 WEEDS		235.00	0.00	235.00	
64-14-33-433-002	Albritton, James E	GRASS	235.00	0.00	235.00	
19-0007619	12/13/2019 WEEDS		235.00	0.00	235.00	
64-14-33-476-021	Lacewell Group	GRASS	235.00	0.00	235.00	
19-0007569	12/23/2019 WEEDS		235.00	0.00	235.00	

			Trial Run			
Cust ID	Customer Name		Item Code	Balance	Additional	Tot Transferred
Invoice #	Post Date	Billing Item				
64-14-33-478-030	Diaz Leon Chavez, Miguel A		GRASS	370.00	0.00	370.00
19-0007621	12/13/2019	WEEDS		370.00	0.00	370.00
64-14-33-479-001	Matthews, Mary		GRASS	470.00	0.00	470.00
19-0007567	12/23/2019	WEEDS		235.00	0.00	235.00
19-0007644	12/16/2019	WEEDS		235.00	0.00	235.00
64-14-33-479-002	Crown Enterprises Inc		GRASS	470.00	0.00	470.00
19-0007568	12/23/2019	WEEDS		235.00	0.00	235.00
19-0007643	12/16/2019	WEEDS		235.00	0.00	235.00
64-14-34-102-012	Sapienza, Vince P		GRASS	235.00	0.00	235.00
19-0007445	11/05/2019	WEEDS		235.00	0.00	235.00
64-14-34-156-007	Blakely, Bennie		GRASS	235.00	0.00	235.00
19-0007446	11/05/2019	WEEDS		235.00	0.00	235.00
64-19-04-105-001	Marcreeana D Ballford		GRASS	165.00	0.00	165.00
19-0007634	12/16/2019	WEEDS		165.00	0.00	165.00
64-19-04-105-002	Carson, Arzo		GRASS	165.00	0.00	165.00
19-0007635	12/16/2019	WEEDS		165.00	0.00	165.00
64-19-04-107-023	Bell, William		GRASS	235.00	0.00	235.00
19-0007549	12/23/2019	WEEDS		235.00	0.00	235.00
64-19-04-127-004	Love Jr., Roy C		GRASS	235.00	0.00	235.00
19-0007474	11/05/2019	WEEDS		235.00	0.00	235.00
64-19-05-204-011	Simpson, Timmie		GRASS	165.00	0.00	165.00
19-0007455	11/05/2019	WEEDS		165.00	0.00	165.00
64-19-05-206-026	Special Touch Learning Center		GRASS	235.00	0.00	235.00
19-0007541	12/10/2019	WEEDS		235.00	0.00	235.00
64-19-05-207-032	Lenoir, Lazarus		GRASS	235.00	0.00	235.00
19-0007454	11/05/2019	WEEDS		235.00	0.00	235.00
64-19-05-226-001	Special Touch Learning Center		GRASS	235.00	0.00	235.00
19-0007548	12/23/2019	WEEDS		235.00	0.00	235.00
64-19-05-252-021	Jackson, Zerlina		GRASS	235.00	0.00	235.00
19-0007566	12/23/2019	WEEDS		235.00	0.00	235.00

09/29/2020
01:48 PM

Tax Assignment Report for City of Pontiac

Page: 10/18
DB: Pontiac

			Trial Run			
Cust ID	Customer Name		Item Code	Balance	Additional	Tot Transferred
Invoice #	Post Date	Billing Item				
64-19-05-252-031	Special Touch Learning Center		GRASS	235.00	0.00	235.00
19-0007611	12/23/2019	WEEDS		235.00	0.00	235.00
64-19-05-252-033	Wright, Beatrice L		GRASS	470.00	0.00	470.00
19-0007544	12/23/2019	WEEDS		235.00	0.00	235.00
19-0007610	12/23/2019	WEEDS		235.00	0.00	235.00
64-19-05-254-021	Special Touch Learning Center		GRASS	235.00	0.00	235.00
19-0007545	12/23/2019	WEEDS		235.00	0.00	235.00
64-19-05-278-030	JC Transporting Inc		GRASS	235.00	0.00	235.00
19-0007633	12/16/2019	WEEDS		235.00	0.00	235.00
64-19-05-278-034	Robinson, Ruby Y		GRASS	235.00	0.00	235.00
19-0007443	11/05/2019	WEEDS		235.00	0.00	235.00
64-19-05-278-035	Robinson, Ruby Y		GRASS	740.00	0.00	740.00
19-0007440	11/05/2019	WEEDS		505.00	0.00	505.00
19-0007632	12/16/2019	WEEDS		235.00	0.00	235.00
64-19-05-279-028	JC Transporting Inc		GRASS	235.00	0.00	235.00
19-0007547	12/23/2019	WEEDS		235.00	0.00	235.00
64-99-00-930-068	Laundry Lounge		GRASS	230.00	0.00	230.00
19-0007442	11/05/2019	WEEDS		230.00	0.00	230.00
----->	Totals	GRASS		38,705.00		
----->	Grand Total			38,705.00		

Trial Run

Cust ID	Customer Name	Item Code	Balance	Additional	Tot Transferred
Invoice #	Post Date	Billing Item			
		Adjustment '00016009'	successfully created for Invoice '20-0007904'.		
		Adjustment '00016010'	successfully created for Invoice '20-0007905'.		
		Adjustment '00016011'	successfully created for Invoice '19-0007576'.		
		Adjustment '00016012'	successfully created for Invoice '19-0007577'.		
		Adjustment '00016013'	successfully created for Invoice '20-0007912'.		
		Adjustment '00016014'	successfully created for Invoice '20-0007906'.		
		Adjustment '00016015'	successfully created for Invoice '19-0007578'.		
		Adjustment '00016016'	successfully created for Invoice '20-0007907'.		
		Adjustment '00016017'	successfully created for Invoice '19-0007580'.		
		Adjustment '00016018'	successfully created for Invoice '19-0007581'.		
		Adjustment '00016019'	successfully created for Invoice '20-0007908'.		
		Adjustment '00016020'	successfully created for Invoice '19-0007583'.		
		Adjustment '00016021'	successfully created for Invoice '20-0007909'.		
		Adjustment '00016022'	successfully created for Invoice '20-0007910'.		
		Adjustment '00016023'	successfully created for Invoice '19-0007584'.		
		Adjustment '00016024'	successfully created for Invoice '19-0007587'.		
		Adjustment '00016025'	successfully created for Invoice '20-0007911'.		
		Adjustment '00016035'	successfully created for Invoice '19-0007607'.		
		Adjustment '00016051'	successfully created for Invoice '19-0007602'.		
		Adjustment '00016052'	successfully created for Invoice '19-0007452'.		
		Adjustment '00016054'	successfully created for Invoice '19-0007377'.		
		Adjustment '00016066'	successfully created for Invoice '19-0007591'.		

Trial Run

Cust ID Invoice #	Customer Name Post Date	Billing Item	Item Code	Balance	Additional	Tot Transferred
	Adjustment '00016069'	successfully created for Invoice '19-0007439'				
	Adjustment '00016075'	successfully created for Invoice '19-0007592'				
	Adjustment '00016091'	successfully created for Invoice '19-0007620'				
	Adjustment '00016095'	successfully created for Invoice '19-0007374'				
	Adjustment '00016096'	successfully created for Invoice '19-0007593'				
	Adjustment '00016129'	successfully created for Invoice '19-0007594'				
	Adjustment '00016148'	successfully created for Invoice '19-0007476'				
	Adjustment '00016156'	successfully created for Invoice '19-0007465'				
	Adjustment '00016196'	successfully created for Invoice '19-0007485'				
	Adjustment '00016200'	successfully created for Invoice '19-0007637'				
	Adjustment '00016239'	successfully created for Invoice '19-0007451'				
	Adjustment '00016243'	successfully created for Invoice '19-0007450'				
	Adjustment '00016254'	successfully created for Invoice '19-0007603'				
	Adjustment '00016255'	successfully created for Invoice '19-0007436'				
	Adjustment '00016257'	successfully created for Invoice '19-0007437'				
	Adjustment '00016259'	successfully created for Invoice '19-0007380'				
	Adjustment '00016260'	successfully created for Invoice '19-0007466'				
	Adjustment '00016269'	successfully created for Invoice '19-0007487'				
	Adjustment '00016275'	successfully created for Invoice '19-0007383'				
	Adjustment '00016279'	successfully created for Invoice '19-0007608'				
	Adjustment '00016285'	successfully created for Invoice '19-0007612'				
	Adjustment '00016293'	successfully created for Invoice '19-0007489'				
	Adjustment '00016302'	successfully created for Invoice '19-0007491'				

Trial Run

Cust ID	Customer Name	Item Code	Balance	Additional	Tot Transferred
Invoice #	Post Date	Billing Item			
		Adjustment '00016303'	successfully created for Invoice '19-0007378'.		
		Adjustment '00016309'	successfully created for Invoice '19-0007613'.		
		Adjustment '00016315'	successfully created for Invoice '19-0007448'.		
		Adjustment '00016319'	successfully created for Invoice '19-0007463'.		
		Adjustment '00016331'	successfully created for Invoice '19-0007382'.		
		Adjustment '00016342'	successfully created for Invoice '19-0007457'.		
		Adjustment '00016353'	successfully created for Invoice '19-0007458'.		
		Adjustment '00016354'	successfully created for Invoice '19-0007459'.		
		Adjustment '00016355'	successfully created for Invoice '19-0007460'.		
		Adjustment '00016358'	successfully created for Invoice '19-0007461'.		
		Adjustment '00016359'	successfully created for Invoice '19-0007462'.		
		Adjustment '00016360'	successfully created for Invoice '19-0007449'.		
		Adjustment '00016361'	successfully created for Invoice '19-0007381'.		
		Adjustment '00016364'	successfully created for Invoice '19-0007438'.		
		Adjustment '00016372'	successfully created for Invoice '19-0007605'.		
		Adjustment '00016373'	successfully created for Invoice '19-0007614'.		
		Adjustment '00016374'	successfully created for Invoice '19-0007447'.		
		Adjustment '00016377'	successfully created for Invoice '19-0007624'.		
		Adjustment '00016383'	successfully created for Invoice '19-0007615'.		
		Adjustment '00016384'	successfully created for Invoice '19-0007616'.		
		Adjustment '00016401'	successfully created for Invoice '19-0007475'.		
		Adjustment '00016405'	successfully created for Invoice '19-0007470'.		

Cust ID	Customer Name	Item Code	Balance	Additional	Tot Transferred
Invoice #	Post Date	Billing Item			
		Adjustment '00016409'	successfully created for Invoice '19-0007464'.		
		Adjustment '00016416'	successfully created for Invoice '19-0007468'.		
		Adjustment '00016426'	successfully created for Invoice '19-0007444'.		
		Adjustment '00016439'	successfully created for Invoice '19-0007597'.		
		Adjustment '00016440'	successfully created for Invoice '19-0007598'.		
		Adjustment '00016450'	successfully created for Invoice '19-0007366'.		
		Adjustment '00016457'	successfully created for Invoice '19-0007479'.		
		Adjustment '00016463'	successfully created for Invoice '19-0007386'.		
		Adjustment '00016479'	successfully created for Invoice '19-0007480'.		
		Adjustment '00016489'	successfully created for Invoice '19-0007369'.		
		Adjustment '00016496'	successfully created for Invoice '19-0007368'.		
		Adjustment '00016513'	successfully created for Invoice '19-0007492'.		
		Adjustment '00016515'	successfully created for Invoice '19-0007493'.		
		Adjustment '00016518'	successfully created for Invoice '19-0007473'.		
		Adjustment '00016521'	successfully created for Invoice '19-0007646'.		
		Adjustment '00016527'	successfully created for Invoice '19-0007642'.		
		Adjustment '00016528'	successfully created for Invoice '19-0007497'.		
		Adjustment '00016543'	successfully created for Invoice '19-0007384'.		
		Adjustment '00016549'	successfully created for Invoice '19-0007385'.		
		Adjustment '00016554'	successfully created for Invoice '19-0007494'.		
		Adjustment '00016555'	successfully created for Invoice '19-0007387'.		
		Adjustment '00016570'	successfully created for Invoice '19-0007495'.		
		Adjustment '00016592'	successfully created for Invoice '19-0007628'.		

Trial Run

Cust ID	Customer Name	Item Code	Balance	Additional	Tot Transferred
Invoice #	Post Date	Billing Item			

Adjustment '00016593' successfully created for Invoice '19-0007629'.
Adjustment '00016604' successfully created for Invoice '19-0007496'.
Adjustment '00016610' successfully created for Invoice '19-0007617'.
Adjustment '00016611' successfully created for Invoice '19-0007638'.
Adjustment '00016614' successfully created for Invoice '19-0007622'.
Adjustment '00016637' successfully created for Invoice '19-0007552'.
Adjustment '00016640' successfully created for Invoice '19-0007555'.
Adjustment '00016641' successfully created for Invoice '19-0007556'.
Adjustment '00016642' successfully created for Invoice '19-0007647'.
Adjustment '00016653' successfully created for Invoice '19-0007563'.
Adjustment '00016655' successfully created for Invoice '19-0007562'.
Adjustment '00016659' successfully created for Invoice '19-0007639'.
Adjustment '00016665' successfully created for Invoice '19-0007551'.
Adjustment '00016671' successfully created for Invoice '19-0007560'.
Adjustment '00016675' successfully created for Invoice '19-0007561'.
Adjustment '00016678' successfully created for Invoice '19-0007557'.
Adjustment '00016683' successfully created for Invoice '19-0007558'.
Adjustment '00016709' successfully created for Invoice '19-0007367'.
Adjustment '00016715' successfully created for Invoice '19-0007453'.
Adjustment '00016722' successfully created for Invoice '19-0007469'.
Adjustment '00016734' successfully created for Invoice '19-0007364'.
Adjustment '00016740' successfully created for Invoice '19-0007365'.

Trial Run

Cust ID	Customer Name	Item Code	Balance	Additional	Tot Transferred
Invoice #	Post Date	Billing Item			
	Adjustment '00016768'	successfully created for Invoice '19-0007619'			
	Adjustment '00016780'	successfully created for Invoice '19-0007569'			
	Adjustment '00016783'	successfully created for Invoice '19-0007621'			
	Adjustment '00016786'	successfully created for Invoice '19-0007567'			
	Adjustment '00016787'	successfully created for Invoice '19-0007644'			
	Adjustment '00016788'	successfully created for Invoice '19-0007568'			
	Adjustment '00016789'	successfully created for Invoice '19-0007643'			
	Adjustment '00016801'	successfully created for Invoice '19-0007445'			
	Adjustment '00016809'	successfully created for Invoice '19-0007446'			
	Adjustment '00016825'	successfully created for Invoice '19-0007634'			
	Adjustment '00016826'	successfully created for Invoice '19-0007635'			
	Adjustment '00016833'	successfully created for Invoice '19-0007549'			
	Adjustment '00016838'	successfully created for Invoice '19-0007474'			
	Adjustment '00016857'	successfully created for Invoice '19-0007455'			
	Adjustment '00016859'	successfully created for Invoice '19-0007541'			
	Adjustment '00016865'	successfully created for Invoice '19-0007454'			
	Adjustment '00016869'	successfully created for Invoice '19-0007548'			
	Adjustment '00016886'	successfully created for Invoice '19-0007566'			
	Adjustment '00016888'	successfully created for Invoice '19-0007611'			
	Adjustment '00016889'	successfully created for Invoice '19-0007544'			
	Adjustment '00016890'	successfully created for Invoice '19-0007610'			
	Adjustment '00016906'	successfully created for Invoice '19-0007545'			
	Adjustment '00016924'	successfully created for Invoice '19-0007633'			

09/29/2020
01:48 PM

Tax Assignment Report for City of Pontiac

Page: 18/18
DB: Pontiac

Trial Run

Cust ID	Customer Name	Item Code	Balance	Additional	Tot Transferred
Invoice #	Post Date	Billing Item			

Adjustment '00016925' successfully created for Invoice '19-0007443'.

Adjustment '00016928' successfully created for Invoice '19-0007440'.

Adjustment '00016929' successfully created for Invoice '19-0007632'.

Adjustment '00016937' successfully created for Invoice '19-0007547'.

Adjustment '00016940' successfully created for Invoice '19-0007442'.

09/28/2020
10:45 AM

Tax Assignment Report for City of Pontiac

Page: 1/5
DB: Pontiac

			Trial Run			
Cust ID	Customer Name	Item Code	Balance	Additional	Tot Transferred	
Invoice #	Post Date Billing Item					
64-14-08-455-007	Bermudez, Cesar	Litter	62.88	0.00	62.88	
20-0007767	03/17/2020 LCUP		62.88	0.00	62.88	
64-14-16-306-033	Johnson, Cami Alycia	Litter	62.88	0.00	62.88	
20-0007772	03/17/2020 LCUP		62.88	0.00	62.88	
64-14-16-327-015	Cole, Portia D	Litter	62.88	0.00	62.88	
20-0007775	03/18/2020 LCUP		62.88	0.00	62.88	
64-14-20-309-031	Park Terrace Properties	Litter	292.88	0.00	292.88	
20-0007716	02/26/2020 LCUP		292.88	0.00	292.88	
64-14-21-303-027	SK Pontiac Housing LLC	Litter	182.27	0.00	182.27	
19-0007529	11/22/2019 LCUP		182.27	0.00	182.27	
64-14-21-377-034	Tarskaya, Elvira	Litter	62.88	0.00	62.88	
20-0007769	03/17/2020 LCUP		62.88	0.00	62.88	
64-14-22-152-023	Stormer, John	Litter	62.88	0.00	62.88	
20-0007774	03/18/2020 LCUP		62.88	0.00	62.88	
64-14-22-352-011	Barouch, Hubert	Litter	292.88	0.00	292.88	
20-0007715	02/26/2020 LCUP		292.88	0.00	292.88	
64-14-27-151-005	Leak, Elnora	Litter	212.27	0.00	212.27	
19-0007429	11/04/2019 LCUP		212.27	0.00	212.27	
64-14-28-380-019	Lombardo, Peter	Litter	62.88	0.00	62.88	
20-0007701	02/05/2020 LCUP		62.88	0.00	62.88	
64-14-28-482-009	Zeelie, Patrick	Litter	62.27	0.00	62.27	
19-0007434	11/05/2019 LCUP		62.27	0.00	62.27	
64-14-28-483-015	Fredrick T Quinn	Litter	162.27	0.00	162.27	
19-0007432	11/04/2019 LCUP		162.27	0.00	162.27	
64-14-29-103-008	Ruggles, Dorothy M	Litter	212.27	0.00	212.27	
20-0007703	02/05/2020 LCUP		212.27	0.00	212.27	
64-14-29-152-010	Klein, Robert	Litter	62.88	0.00	62.88	
20-0007764	03/17/2020 LCUP		62.88	0.00	62.88	
64-14-29-358-001	Jim Stella Art, LLC	Litter	82.27	0.00	82.27	
19-0007428	11/04/2019 LCUP		82.27	0.00	82.27	

09/28/2020
10:45 AM

Tax Assignment Report for City of Pontiac

Page: 2/5
DB: Pontiac

		Trial Run				
Cust ID	Customer Name	Item Code	Balance	Additional	Tot Transferred	
Invoice #	Post Date Billing Item					
64-14-30-477-013	PV Cleaning & Investments, LLC	Litter	62.88	0.00	62.88	
20-0007762	03/17/2020 LCUP		62.88	0.00	62.88	
64-14-31-106-001	Dodson, Anita L	Litter	62.88	0.00	62.88	
20-0007765	03/17/2020 LCUP		62.88	0.00	62.88	
64-14-31-234-017	RE Fund Lansing 1 LLC	Litter	112.27	0.00	112.27	
19-0007533	11/22/2019 LCUP		112.27	0.00	112.27	
64-14-31-381-011	TCS Homes LLC	Litter	122.88	0.00	122.88	
20-0007761	03/17/2020 LCUP		122.88	0.00	122.88	
64-14-31-457-003	Zuhause Real Estate LLC	Litter	62.88	0.00	62.88	
20-0007763	03/17/2020 LCUP		62.88	0.00	62.88	
64-19-04-104-019	Lane Jr, Joe	Litter	62.27	0.00	62.27	
19-0007530	11/22/2019 LCUP		62.27	0.00	62.27	
----->	Totals Litter		2,425.60			
----->	Grand Total		2,425.60			

09/28/2020
10:45 AM

Tax Assignment Report for City of Pontiac

Page: 4/5
DB: Pontiac

Trial Run

Cust ID	Customer Name	Item Code	Balance	Additional	Tot Transferred
Invoice #	Post Date	Billing Item			

09/28/2020
10:45 AM

Tax Assignment Report for City of Pontiac

Page: 5/5
DB: Pontiac

Trial Run

Cust ID	Customer Name	Item Code	Balance	Additional	Tot Transferred
Invoice #	Post Date	Billing Item			

Warnings Message /
 Details

Invoice '20-0007851' skipped.
Invoice '20-0007851' must be journalized before transferring to Tax.

Invoice '20-0007999' skipped.
Invoice '20-0007999' must be journalized before transferring to Tax.

#10

RESOLUTION

Resolution of the Pontiac City Council

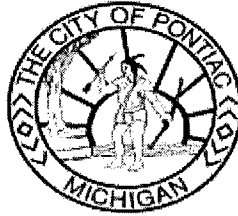

Whereas, the City of Pontiac timely approved the 2020-2021 budget on June 30, 2020 and;

Whereas, the City has received a grant from the Community Foundation of Southeast Michigan to support the development of an internal grants management process and system and;

Whereas, the Mayor is proposing to the City Council to increase the budgeted revenue for the current fiscal year 2020-2021 in the amount of \$100,000 for grant income, and increase the appropriations in the amount of \$100,000, representing reimbursed grant expenditures.

Whereas, the increased appropriations will not cause the fund balance in the General Fund to go below the policy mandated thresholds and;

NOW THEREFORE be resolved that the City Council hereby approves the budget amendment to increase budgeted revenues in the amount of \$100,000 to the General Fund in account 101-000-532.000 –Grant Income, and appropriations in the amount of \$100,000 to a General Fund account

#11

RESOLUTION



CITY OF PONTIAC
Department of Building Safety & Planning
PLANNING DIVISION

47450 Woodward Ave | Pontiac, Michigan 48342
TELEPHONE: (248) 758-2800

Mayor Deirdre Waterman

TO: HONORABLE MAYOR WATERMAN, COUNCIL PRESIDENT WILLIAMS & PONTIAC CITY COUNCIL

FROM: VERN GUSTAFSSON, PLANNING MANAGER

**SUBJECT: THIRD AMENDMENT TO 425 DEVELOPMENT AGREEMENT
PLANET FITNESS SIGN
VILLAGE AT BLOOMFIELD**

DATE: SEPTEMBER 29, 2020 – REVISED OCTOBER 1, 2020

Third Amendment Overview

On June 17, 2020, Planet Fitness, in conjunction with REDICO, received approval from the Joint Development Council [JDC] for wall signs for an approximately 30,000 sq.ft. building, subject to seeking an amendment to the Development Agreement for wall signs. The attached Third Amendment to the Development Agreement was reviewed and approved to form by the City Attorney.

The First Amendment to the Village at Bloomfield Development Agreement requires that primary building signs are allowed at 6% of the building façade area and total signage not to exceed 150 sq. ft. The Planet Fitness facility is classified as 'Building B', which allows one primary wall sign and a secondary wall sign. The secondary wall sign area shall not exceed 50% of the primary sign area.

The exterior elevations illustrate wall signs on the east and south elevations of the Planet Fitness building. These two signs are proposed with a combined total sign area of 255 sq.ft. The 9 ft. x 22 ft. primary sign (200 sq.ft.) is 3.5% of the façade area that faces Telegraph Road. The 6.75 ft. x 8 ft. secondary sign (55 sq.ft.) is 1% of the façade area that faces toward the Hampton Inn and Suites. The secondary sign is less than 50% of the primary signage. However, the proposed overall wall sign area exceeds the requirements by 105 sq.ft.

Given the building is setback over 500 ft. and the building's main entrance is facing away from Telegraph Road, the revised wall signage appears compatible with the surrounding building signs within the Village at Bloomfield. It is recommended that the signs also include dimming capabilities with any required dimming of the illumination to be negotiated internally by the municipalities and REDICO consistent with the Second Amendment to the Development Agreement.

**Amendment to the 425 Development Agreement
Village at Bloomfield
PROPOSED RESOLUTION**

WHEREAS, On June 17, 2020, Planet Fitness received approval from the Joint Development Council [JDC] for wall mounted signs for an approximately 30,000 sq.ft. building, subject to seeking an amendment to the Development Agreement for wall signs.

WHEREAS, A previous amendment to the Village at Bloomfield Development Agreement requires that primary building signs are allowed at 6% of the building façade area and total signage not to exceed 150 sq. ft. The Planet Fitness facility is classified as 'Building B', which allows one primary wall sign and a secondary wall sign. The secondary wall sign area shall not exceed 50% of the primary sign area.

WHEREAS, The wall signs on the east and south elevations of the Planet Fitness building are proposed with a combined total sign area of 255 sq.ft. The proposed overall wall sign area exceeds the requirements by 105 sq.ft.

WHEREAS, The amendment to the Development Agreement would follow previous actions by the JDC that the signs would include backlighting and dimming capabilities, based on a timer and an on/off switch. The dimming of the signs shall be determined by the surrounding government municipalities and the developer when it is deemed necessary.

WHEREAS, the proposed amendment has been initially reviewed by the City Attorney, presented by REDICO and approved by Bloomfield Township Board of Trustees on August 24, 2020.

THEREFORE BE IT RESOLVED that the Pontiac City Council for the City of Pontiac to amend the Development Agreement at the Village at Bloomfield and authorize the City Attorney to finalize the amendment for Mayor's signature.

planet fitness

264" (22')

51 1/2"

12 1/4" Stroke

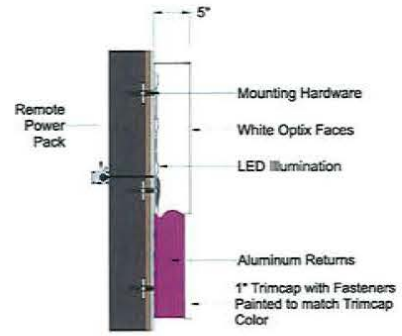

M1 Mounting Detail View

Description:
 (Qty: 1) Face illuminating channel letters.
 • 3/16" White Optix #2406 faces with inlayed translucent vinyl graphics (see D1).
 • Stock 1" trimcap with fasteners painted to match trimcap color.
 • Painted aluminum returns with internal LED illumination.
 • Weep holes with brake formed aluminum weep hole baffle - Typ.
 • Mounted flush to fascia

Typeface/Logo:
 • Logo per supplied Version 20.1 2020 standards

Colors:
 • Returns - Painted AkzoNobel GG #490-D6 (matching Mulberry vinyl)
 • Trimcap - 1" Stock White trimcap with trimcap fasteners painted White
 • Faces - White Optix #2406 plexi
 • Graphics - Oracal 8800 #422 Mulberry translucent vinyl (inlayed vinyl see D1)
 • LEDs - White

Installation:
 • By Local Installer
 • Power by Others
 • This sign is intended to be installed in accordance with the requirements of Article 600 of the National Electrical Code (NEC) and/or other applicable Local Electrical Codes (LEC). This includes proper grounding and bonding of the sign.
 • No exposed conduits or junction boxes on building fascia is permitted
 • Non-corrosive fasteners
 • Non-corrosive pipe sleeve set in sealant for each attachment into the fascia

E1 Elevation: (Qty: 1) #10525.1 Face Illuminating Channel Letters
 108-1/2" x 264" = 199 Sq. Ft.

Centered In Wall Area
 35-13/16" +/-

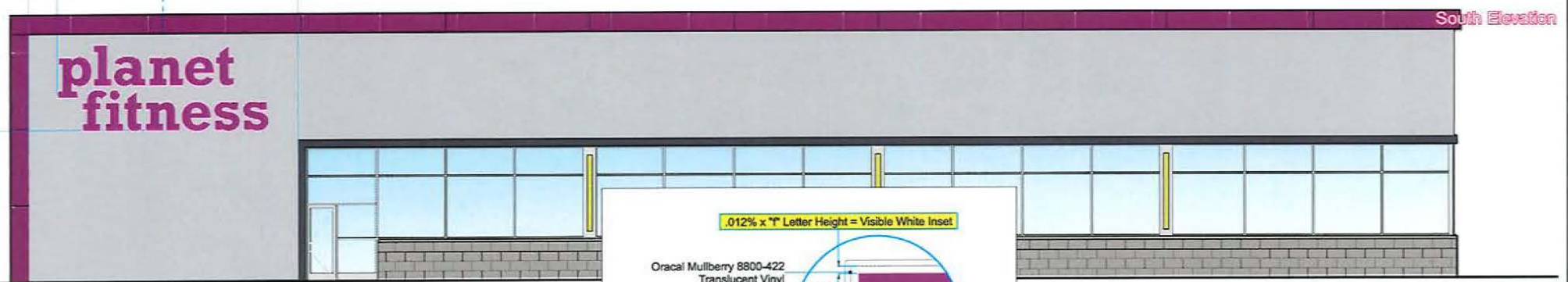

South Elevation

Rendering Elevation View, Proposed

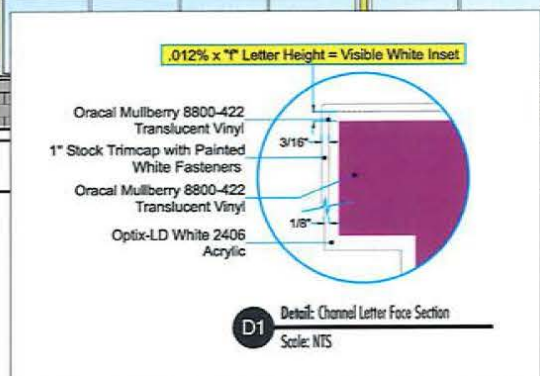

D1 Detail: Channel Letter Face Section
 Scale: NTS



Night View

Account Manager:
 Scott Spaulding

Date:
 03.05.20 D.5

Revisions:
 06.26.20 1 SM

Revisions:



1.508.393.8200

FAX 1.508.393.4244

Customer Approval Acct. Manager Approval

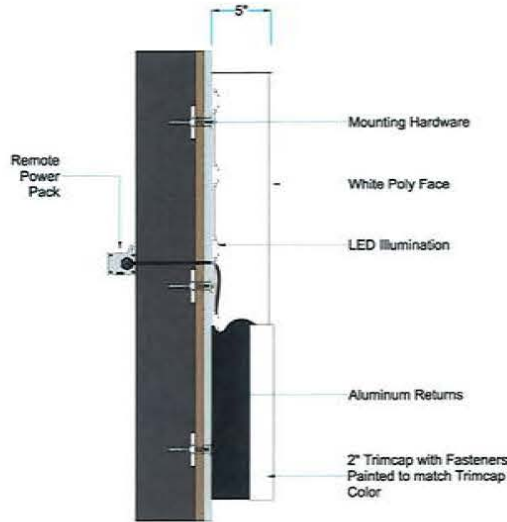

Description:
 (Qty: 1) Face illuminating gear icon.
 • White polycarbonate face with PureColor Print Technology 3619 Premium Luster graphics
 • Stock 2" trimcap & clips with fasteners painted to match trimcap color
 • Stock color aluminum returns
 • LED illumination
 • Mounted flush to fascia with required hardware.

Typeface/Logo:
 • 2017 Art on File

Colors:
 • Returns - Pre-Finished Black
 • Trimcap - 2" Stock White with Fasteners Painted to Match
 • Face - White Polycarbonate
 • Graphics - PureColor Printed Yellow PMS #108c
 - PureColor Printed Purple PMS #2415c
 - PureColor Printed Black (100%)
 • LEDs - White

Installation:
 • By Local Installer
 • Power by Others
 • This sign is intended to be installed in accordance with the requirements of Article 600 of the National Electrical Code (NEC) and/or other applicable Local Electrical Codes (LEC). This includes proper grounding and bonding of the sign.
 • No exposed conduits or junction boxes on building fascia is permitted
 • Non-corrosive fasteners
 • Non-corrosive pipe sleeve set in sealant for each attachment into the fascia

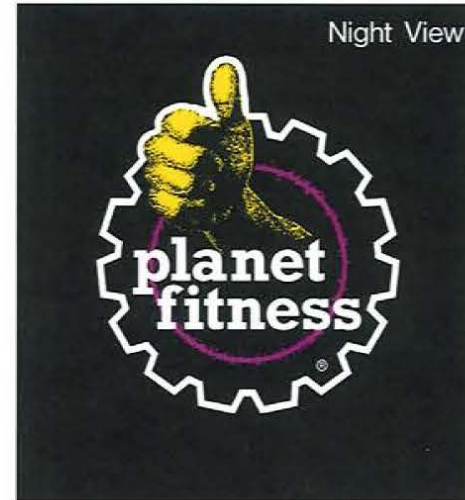

Elevation: (Qty: 1) #10525.1 Face Illuminating Gear Icon
 96-3/4" x 81-3/4" = 55 Sq. Ft.

M1 Mounting Detail View

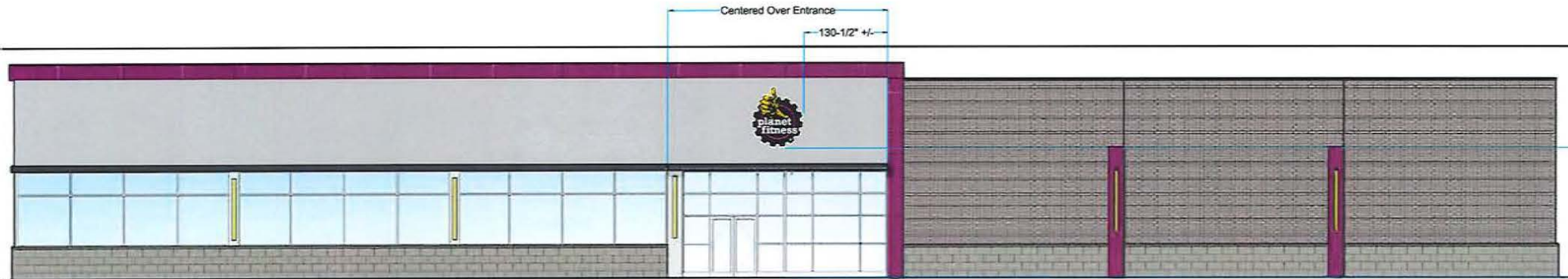

Ordering Elevation View, Proposed

Account Manager:
 Scott Spaulding

File:
 PF BloomfieldMI east gear 1b.plt

Date:
 03.04.20 D.75

Designer:
 Pete Rivera

Revisions:
 06.26.20 .75 SM

Revisions:



1.508.393.8200

FAX 1.508.393.4244

Customer Approval Acct. Manager Approval

CHARTER TOWNSHIP OF BLOOMFIELD and THE CITY OF PONTIAC

JOINT DEVELOPMENT COUNCIL MEETING

Wednesday, June 17, 2020 AT 10:00 A.M.

**Electronic Meeting Hosted By:
Pontiac City Hall
47450 Woodward Avenue
Pontiac, MI
Telephone: (248) 758-3000**

I. ATTENDANCE:

Present:

JDC Members:

Leo Savoie, Bloomfield Township Supervisor
Deirdre Waterman, Mayor, Pontiac
Dennis Cowan, Chair

Staff:

Vern Gustafsson, Planning Manager for the City of Pontiac.
Patricia Voelker, Director of Planning, Building and Ordinance Department for
Bloomfield Township

Also Present:

Bryan Rief of PF Michigan Group, LLC
Edward A Eickhoff of PF Michigan Group, LLC
Art Nicholes, Director of Construction

Absent:

None

Dennis Cowan called the meeting to order: 10:07 a.m.

II. MEETING MINUTES:

MOTION by Supervisor Savoie, **SECONDED** by Mayor Waterman to approve the
June 19, 2019 meeting minutes as submitted.

MOTION APPROVED

YEAS: Savoie, Waterman, Cowan

NAYS: None

III. ITEMS FOR DISCUSSION:

A. Sign Review – Planet Fitness

Ms. Volker addressed the Council on the request of wall signage for Planet Fitness and reminded the Council that a year ago the Council approved the final site plan for the Planet Fitness building with the condition that the approval identified further information on the signage. That proposal exceeded the allowable sign area permitted by the Development Agreement as amended.

The revised request shows a primary sign facing Telegraph Road and a secondary sign facing the Hampton Inn and Suites site. Both signs combined are 255 square feet. The ordinance allows for 150 square feet combined. The proposal exceeds the maximum allowed for this building per the Development Agreement as amended.

From the original proposal, Planet Fitness has reduced the primary sign (facing Telegraph) from 238 square feet to 200 square feet and the secondary sign has been reduced to 55 square feet.

As referenced in the Joint Planners report dated June 11, 2020, the Council is asked to consider approval of the alternative signage as presented with consideration of dimming capabilities as part of the wall signage proposal.

If approved, it is further recommended that the Council forward a recommendation to the Pontiac City Council and the Bloomfield Township Board of Trustees to consider approval of an amendment to the Development Agreement to allow the total 255 square foot signage as reviewed by the Council.

Mr. Gustafsson presented the diagrams and description of the location of the signs.

Mr. Rief discussed the location of the building within the Village at Bloomfield and addressed the signage request. Mr. Nicholes stated that the target date of opening is September 1, 2020.

Mayor Waterman asked if there are any more requests for larger signs at the Village of Bloomfield. Ms. Voelker confirmed that there are no further requests for amendments to the Development Agreement regarding signage. At the request of Ms. Shelton, a resident near the Village of Bloomfield, Ms. Volker contacted Ms. Shelton who had asked to be informed of the final signage for Planet Fitness. Ms. Shelton was supportive of a smaller signage proposal.

MOTION by Supervisor Savoie, **SECONDED** by Mayor Waterman to approve the signage package as submitted with the dimming capabilities.

**CHARTER TOWNSHIP OF BLOOMFIELD AND THE CITY OF PONTIAC
JOINT DEVELOPMENT COUNCIL**

June 17, 2020

Page 3 of 3

Mayor Waterman requested a presentation to be presented by Dennis Cowan and Mr. McCafferty from REDICO before the City Council indicating the before and after images and all the progress up to date. Mayor Waterman would like to bring the citizens up to date. This presentation will be concurrent with the submission of this proposal.

MOTION APPROVED

YEAS: Savoie, Waterman, Cowan

NAYS: None

**IV. NEXT REGULAR MEETING DATE - Wednesday, July 15, 2020 at
10:00 a.m. at Bloomfield Township**

V. ADDITIONAL BUSINESS:

None

VI. PUBLIC COMMENT:

None

V. ADJOURNMENT:

MOTION by Mayor Waterman, **SECONDED** by Supervisor Savoie to adjourn the meeting at 10:36 a.m.

MOTION APPROVED

YEAS: Savoie, Waterman, Cowan

NAYS: None

Respectfully submitted,
Peggy Raymo
Administrative Assistant to Leo Savoie

JDC Memorandum

Date: June 11, 2020

To: Joint Development Council

From: Patti Voelker, Township Director of Planning, Building & Ordinance
Vern Gustafsson, Pontiac Planning Manager

Re: Planet Fitness Wall Signage

History

At the June 19, 2019 meeting, the Joint Development Council (JDC) reviewed the proposed new Planet Fitness building which included a signage proposal that exceeded the allowable square footage of signage for a "Building B" as denoted in the First Amendment of the Development Agreement documents. As such, it allows primary building signs at 6% of the façade area and total signage not to exceed 150 sq. ft. The secondary wall sign area shall not exceed 50% of the primary sign area.

The proposal included two wall signs located on the east and south elevations that measured 26.5 ft. by 9 ft. (238.5 sq.ft.) for a total combined signage area of 477 sq.ft. The proposed wall sign area exceeded the requirements by 327 sq. ft.

The JDC approved the Final Site Plan for the Planet Fitness building at 1935 S. Telegraph Road subject to compliance with conditions stated in the joint planners report dated June 11, 2019 and conditioned upon providing dimensions and details of proposed Planet Fitness interior wayfinding building signs and seeking an amendment to the Development Agreement for wall signage.

Proposal

We have received a request from Planet Fitness/REDICO to accept the following alternative wall signage proposal. The applicant proposes two signs with a combined total sign area of 255 sf. The 9 ft. x 22 ft. primary sign (200sf) is 3.5% of the façade area facing Telegraph Road while the 6.75 ft. x 8 ft. secondary sign (55 sf) is 1% of the façade facing southerly toward Hampton Inn and Suites. The secondary sign is less than 50% of the primary signage. However, the proposed wall sign area exceeds the requirements by 105 sq. ft.

Given the building is setback over 500 ft. and the building's main entrance is facing southerly and away from Telegraph Road, the revised wall signage appears compatible with the surrounding building signage within the Village at Bloomfield. It is recommended that the signage also include dimming capabilities with any required dimming of the illumination to be negotiated internally by the municipalities and Redico consistent with the Second Amendment to the Development Agreement.

It is recommended that the JDC consider under what conditions signage approval may be granted and forward the JDC's actions to the Bloomfield Township Board of Trustees and City of Pontiac City Council for consideration of an amendment to the Development Agreement for the signage as presented.

CHARTER TOWNSHIP OF BLOOMFIELD and THE CITY OF PONTIAC

JOINT DEVELOPMENT COUNCIL MEETING

Wednesday, June 19, 2019 AT 10:00 A.M.

**Pontiac City Hall
47450 Woodward Avenue
Pontiac, MI
Telephone: (248) 758-3000**

I. ATTENDANCE:

Present:

JDC Members:

Leo Savoie, Bloomfield Township Supervisor
Dennis Cowan, Chair

Staff:

Vern Gustafsson, Planning Manager for the City of Pontiac.
Patricia Voelker, Director of Planning, Building and Ordinance Department for
Bloomfield Township

Absent: Deirdre Waterman, Mayor, Pontiac

Dennis Cowan called the meeting to order: 10:03 a.m.

II. MEETING MINUTES:

MOTION by Supervisor Savoie, **SECONDED** by Chairmen Cowan to approve the
November 28, 2019 meeting minutes as submitted.

YEAS: Savoie, Cowan

NAYS: None

MOTION APPROVED

III. ITEMS FOR DISCUSSION:

A. Site Plan Review – Proposed Planet Fitness

**CHARTER TOWNSHIP OF BLOOMFIELD AND THE CITY OF PONTIAC
JOINT DEVELOPMENT COUNCIL**

June 19, 2019

Page 2 of 3

PowerPoint Presentation by:

Bryan Reif, CRD, CLS, Planet Fitness, Co-Owner Michigan Group
Mitchell Stanley, Senior Project Manager, RGLA Solutions

- Mr. Reif narrated a PowerPoint presentation reviewing the interior of the Planet Fitness facility. This facility will include 120 pieces of cardio, and over 200 pieces of strength equipment. Mr. Reif also presented photos of amenities including high end locker rooms and bathrooms.
- Mr. Stanley reviewed the topography of the plans as submitted.

Reviewed by:

Vern Gustafsson, Planning Manager for the City of Pontiac
Patti Voelker, Director of Planning, Building & Ordinance, Bloomfield Township

The proposed Planet Fitness is a 30,048 sq. ft. facility on 2.77 acres of vacant land within the Village at Bloomfield development. The proposal was reviewed in accordance with the ordinance regulations for the T-C, Town Center District and the Development Agreement, as amended.

The Site Plan dated June 10, 2019 follows the Village at Bloomfield Master Plan and is mostly compliant with the Town Center Ordinance and the Development Agreement, as amended. Based on the joint planners report, Gustafsson and Voelker requested the JDC consider approving a Final Site Plan for 1935 S. Telegraph Road, Planet Fitness, and Redico subject to compliance with the following conditions:

1. Verification to be provided that notes compliance with rooftop utility equipment location and required screening.
2. Provide dimensions and details of proposed Planet Fitness interior wayfinding building signs and seek amendment to the Development Agreement for wall signs.
3. Seek a variance from the JDC from the Town Center Ordinance requiring parking lot screening with evergreen trees spaced 30 foot on-center within a 10ft. greenbelt.
4. Compliance with the Town Center Ordinance requiring parking spaces to be 10 ft. x 20 ft. in accordance with the definition of parking space with 9 ft. x 18 ft. parking spaces shown, or seek a variance from the JDC.
5. Compliance with all Building Construction Codes, Fire Code, and City permitting requirements.
6. Approval for full engineering plan review, under separate application.

Chairman Cowan disclosed that the law firm of which he is a member has represented Planet Fitness for other matters. The work was done by another attorney and not at all by Chairman Cowan. The firm is not working on this matter at all and will not do so in the future. There is no financial interest in this proposal before the JDC. Chairman Cowan

**CHARTER TOWNSHIP OF BLOOMFIELD AND THE CITY OF PONTIAC
JOINT DEVELOPMENT COUNCIL**

June 19, 2019

Page 3 of 3

stated he feels this does not impair his independent judgement in any way. He has voted on every site plan so far and intends to vote on this also.

MOTION by Supervisor Savoie, **SECONDED** by Chairmen Cowan for approval of the Final Site Plan for 1935 S. Telegraph Road, Planet Fitness, and REDICO as stated subject to the stated conditions from the joint planners report.

YEAS: Savoie, Cowan

NAYS: None

MOTION APPROVED

**IV. NEXT REGULAR MEETING DATE - Wednesday, July 17, 2019 at
10:00 a.m. at Bloomfield Township**

V. ADDITIONAL BUSINESS:

Update from Tim McCafferty, Senior Project Manager, REDICO

- 3 locations remain on the site yet to be developed.
- Hampton Inn & Suites has all their foundations in with the stair towers standing.
- Edward Rose & Sons has the Club building nearly done with the first apartment building under construction.
- Henry Ford Medical Center project is 50% complete.
- Menards will open next week.

VI. PUBLIC COMMENT:

Tony Jordan, 626 Pearsall
Paul Ramer 1865 Telegraph

V. ADJOURNMENT:

MOTION by Supervisor Savoie, **SECONDED** by Chairmen Cowan to adjourn the meeting at 10:35 a.m.

YEAS: Savoie, Cowan

NAYS: None

MOTION APPROVED

Respectfully submitted,
Peggy Raymo

THIRD AMENDMENT TO DEVELOPMENT AGREEMENT

Dated: _____, 2020

Prepared by:

Jaffe, Raitt, Heuer & Weiss, P.C.

Emily R. Schey, Esq.

27777 Franklin Road

Suite 2500

Southfield, Michigan 48034

THIRD AMENDMENT TO DEVELOPMENT AGREEMENT

THIS THIRD AMENDMENT TO DEVELOPMENT AGREEMENT ("Third Amendment") effective as of the ___ day of _____, 2020, is made by and between the CITY OF PONTIAC, a Michigan home rule city ("City"), the CHARTER TOWNSHIP OF BLOOMFIELD ("Township") and BLOOMFIELD VILLAGE OWNER, LLC, a Delaware limited liability company ("Developer").

WHEREAS, Township and City entered into that certain Development Agreement dated November 27, 2002 ("Original Agreement"), as amended by that certain First Amendment to Development Agreement dated March 2, 2017 ("First Amendment") and that certain Second Amendment to Development Agreement dated July 22, 2019 ("Second Amendment", and collectively with the Original Agreement and the First Amendment, the "Development Agreement") with Harbor Telegraph 2103 L.L.C., Bloomfield Acres Acquisition Company L.L.C., Harbor Telegraph-1881 L.L.C., Harbor Telegraph-1899 L.L.C. and Harbor Vogue Plaza L.L.C. (collectively, "Harbor");

WHEREAS, affiliates of Harbor (collectively "Harbor Affiliates") made two separate mortgages (the "Mortgages") to Wells Fargo Bank, National Association ("Wells Fargo"), each duly recorded in the Office of the Register of Deeds, in and for the County of Oakland, identified specifically as a Mortgage dated December 27, 2006, recorded in Liber 38625, on Page 572; a Mortgage dated December 27, 2006, recorded in Liber 38673, on Page 78; as assigned to Bloomfield Village Investor Holdings, LLC, a Delaware limited liability company ("BVI"), by assignment dated October 10, 2014, recorded in Liber 47057, on Page 452, of Oakland County Records, upon which suit was commenced and judgment was obtained at a session of the Circuit Court for the County of Oakland sitting at the Court House in the City of Pontiac, Michigan, said judgment obtained in Case No. 09-103301-CH (the "Case") on the 7th Day of September, 2011, in favor of Wells Fargo and against Harbor Affiliates, MV Bloomfield LLC, B & V Construction, Inc., B & S Resteel, Inc., et. al., foreclosing the two separate certain Mortgages as above recorded which judgment was assigned to BVI on October 10, 2014, and confirmed by order entered in the Case on October 21, 2014;

WHEREAS, in each of the Mortgages, Harbor Affiliates mortgaged, conveyed and assigned with the power of sale the Land (as defined in the Development Agreement and legally described on **Exhibit A** hereto) including all development rights and credits relating to the Land.

WHEREAS, pursuant to the judgment obtained in the Case, the Land, along with all personal property, licenses, agreements, general intangibles, instruments, documents, all development rights and development credits, and all permits, consents, approvals, licenses, authorizations and other rights granted by, given by or obtained from, any governmental entity with respect to the Land, was transferred to BVI via that certain Sheriff's Deed on Foreclosure of Real Estate dated January 13, 2015, and recorded in Liber 47821, Page 175, Oakland County Records;

WHEREAS, BVI subsequently transferred the Land to the Developer via that certain Quit

Claim Deed dated June 15, 2015, and recorded in Liber 48473, Page 885, Oakland County Records; and

WHEREAS, the parties desire to amend the Development Agreement on the terms and conditions stated in this Third Amendment,

NOW THEREFORE, in consideration of the premises and the mutual covenants and conditions contained in the Development Agreement, as amended by this Third Amendment, the parties agree as follows:

1. The Development Agreement is incorporated herein and all of the terms and conditions shall remain the same except as expressly modified by this Third Amendment. In the event of a conflict between a provision in the Development Agreement and a provision in this Third Amendment, the provision in this Third Amendment shall be controlling. All capitalized words in this Third Amendment shall have the meaning given to those words in the Development Agreement unless the context clearly indicates to the contrary.

2. Section 7.d.3.a of the Development Agreement is hereby amended by adding the following paragraph:

“Notwithstanding the terms set forth in the preceding paragraphs, the signage mounted on the walls of Building B, as shown on **Exhibit B** attached to this Third Amendment and made a part hereof, shall be permitted up to a total of 255 square feet, with the 9 foot x 22 foot primary sign being mounted on the façade of Building B facing Telegraph Road, and with the 6.75 foot x 8 foot secondary sign being mounted on the façade of Building B facing southerly towards the hotel (currently, Hampton Inn and Suites) location. All back light illumination of the signage shall have dimming capabilities to reduce the intensity of the light. Additionally, backlighting shall have an adjustable timer setting installed to effectuate dimming and other functions (e.g. on/off) when necessary. Any required dimming of the illuminated signs will be negotiated internally by the City, Township and Developer.”

3. This Third Amendment may be executed in any number of counterparts and each such counterpart hereof shall be deemed to be an original instrument, but all such counterparts together shall constitute but one agreement. The signature and acknowledgment page from one or more counterparts may be detached for filing with any other executed counterparts of this Third Amendment. To the extent of any conflict between the Development Agreement and this Third Amendment, the terms of this Third Amendment shall control.

4. The parties agree that facsimile or electronic signatures shall be considered the same as an original signature for all purposes under this Third Amendment.

[Signature Page Follows]

IN WITNESS WHEREOF, the parties have entered into this Third Amendment on the day and year below.

**CHARTER TOWNSHIP OF
BLOOMFIELD**

By: _____
Name: _____
Its: _____

CITY OF PONTIAC

By: _____
Name: _____
Its: _____

**BLOOMFIELD VILLAGE OWNER,
LLC, a Delaware limited liability company**

By: Bloomfield Village Investor
Holdings, LLC, a Delaware limited
liability company

By: _____
Name: _____
Its: Authorized Signatory

[Signature Page to Third Amendment to Development Agreement]
[Notary Page Follows]

STATE OF MICHIGAN)
) ss.
COUNTY OF OAKLAND)

On this ____ day of _____, 2020, the foregoing Third Amendment was acknowledged before me by _____, the _____ of the Charter Township of Bloomfield, on behalf of said Charter Township.

Notary Public, _____ County, Michigan
My Commission expires: _____
Acting in _____ County, Michigan

STATE OF MICHIGAN)
) ss.
COUNTY OF OAKLAND)

On this ____ day of _____, 2020, the foregoing Third Amendment was acknowledged before me by _____, the _____ of the City of Pontiac, on behalf of the City.

Notary Public, _____ County, Michigan
My Commission expires: _____
Acting in _____ County, Michigan

STATE OF MICHIGAN)
) ss.
COUNTY OF OAKLAND)

On this ____ day of _____, 2020, the foregoing Third Amendment was acknowledged before me by _____, the Authorized Signatory of Bloomfield Village Investor Holdings, LLC, a Delaware limited liability company, which is the sole member of Bloomfield Village Owner, LLC, a Delaware limited liability company, on behalf of said company.

Notary Public, _____ County, Michigan
My Commission expires: _____
Acting in _____ County, Michigan

[Notary Page to Third Amendment to Development Agreement]

EXHIBIT A

Legal Description of Land

PART OF UNIT 1, ALL OF UNITS 4 AND 5 OF BLOOMFIELD PARK CONDOMINIUM, ACCORDING TO THE MASTER DEED RECORDED IN LIBER 35092, PAGE 207, AND AMENDED AND RESTATED MASTER DEED RECORDED IN LIBER 36671, PAGE 569 AND FIRST AMENDMENT TO THE AMENDED AND RESTATED MASTER DEED, RECORDED IN LIBER 50424, PAGE 632, AS AMENDED, AND DESIGNATED AS OAKLAND COUNTY CONDOMINIUM SUBDIVISION PLAN NO. 1718 , TOGETHER WITH RIGHTS IN THE GENERAL COMMON ELEMENTS AND THE LIMITED COMMON ELEMENTS AS SHOWN ON THE MASTER DEED AND AS DESCRIBED IN ACT 59 OF THE PUBLIC ACTS OF 1978, AS AMENDED, ALL BEING A PART OF THE NORTHEAST 1/4 OF SECTION 6 AND THE WEST 1/2 OF SECTION 5, TOWN 2 NORTH, RANGE 10 EAST, BLOOMFIELD TOWNSHIP (CONDITIONALLY TRANSFERRED TO THE CITY OF PONTIAC), OAKLAND COUNTY, MICHIGAN, BEING MORE PARTICULARLY DESCRIBED AS: COMMENCING AT THE WEST 1/4 CORNER OF SECTION 5, ALSO BEING THE EAST 1/4 CORNER OF SECTION 6, TOWN 2 NORTH, RANGE 10 EAST; THENCE NORTH 01 DEGREES 59 MINUTES 37 SECONDS WEST, 698.81 FEET ALONG THE WEST LINE OF SAID SECTION 5, ALSO BEING THE EAST LINE OF SAID SECTION 6, TO A POINT ON THE NORTHERLY RIGHT-OF-WAY LINE OF TELEGRAPH ROAD (204 FEET WIDE), SAID POINT BEING THE POINT OF BEGINNING; THENCE NORTH 50 DEGREES 40 MINUTES 54 SECONDS WEST ALONG SAID NORTHERLY RIGHT OF WAY LINE OF TELEGRAPH ROAD, 203.72 FEET; THENCE NORTH 39 DEGREES 19 MINUTES 06 SECONDS EAST, 125.00 FEET; THENCE SOUTH 50 DEGREES 40 MINUTES 54 SECONDS EAST, 91.05 FEET; THENCE NORTH 02 DEGREES 13 MINUTES 10 SECONDS WEST, 768.44 FEET; THENCE NORTH 87 DEGREES 20 MINUTES 36 SECONDS EAST, 1275.66 FEET; THENCE NORTH 87 DEGREES 54 MINUTES 40 SECONDS EAST, 1146.85 FEET; THENCE SOUTH 05 DEGREES 30 MINUTES 10 SECONDS EAST, 120.14 FEET TO THE NORTHWEST CORNER OF "FAIRVIEW HEIGHTS SUBDIVISION" AS RECORDED IN LIBER 22 OF PLATS, ON PAGE 7, OAKLAND COUNTY RECORDS; THENCE SOUTH 05 DEGREES 21 MINUTES 37 SECONDS EAST, 1527.35 FEET TO THE CENTER POST OF SAID SECTION 5; THENCE SOUTH 87 DEGREES 49 MINUTES 01 SECONDS WEST, 1018.13 FEET; THENCE NORTH 02 DEGREES 32 MINUTES 58 SECONDS WEST, 498.50 FEET; THENCE SOUTH 87 DEGREES 10 MINUTES 18 SECONDS WEST, 200.00 FEET; THENCE NORTH 85 DEGREES 26 MINUTES 04 SECONDS EAST 58.08 FEET; THENCE NORTH 71 DEGREES 29 MINUTES 42 SECONDS WEST, 320.96 FEET; THENCE SOUTH 39 DEGREES 19 MINUTES 06 SECONDS WEST, 188.70 FEET; THENCE NORTH 50 DEGREES 40 MINUTES 54 SECONDS WEST, 352.08 FEET; THENCE SOUTH 39 DEGREES 19 MINUTES 06 SECONDS WEST, ALONG THE NORTHWESTERLY LINE OF LOTS 40 AND 51 OF SAID PLAT, NOW THE NORTHWESTERLY LINE OF LOTS 51 AND 64 OF THE AMENDED PLAT OF BLOOMFIELD ACRES AS RECORDED IN LIBER 297 OF PLATS, ON PAGES 17 AND 18 OF THE OAKLAND COUNTY RECORDS, 360.00 FEET TO THE SOUTHWEST CORNER OF LOT 51 OF SAID AMENDED PLAT; THENCE NORTH 50

DEGREES 40 MINUTES 54 SECONDS WEST, 407.45 FEET TO THE POINT OF BEGINNING.

Tax ID Nos.: 19-05-159-004, 19-05-159-005 and part of 19-05-159-006.

Formerly described as:

Part of Bloomfield Acres Subdivision Lots 1 thru 30, Lots 41 thru 50, and Lot 63, and also that part of Hood Road, Rotsel Road and Myrtle Road, which are adjoining, said above described lots in Bloomfield Acres Subdivision as recorded in Liber 41 Page 49 of Plats of Oakland County Records, and also Tax Parcels: 19-05-176-001, 19-05-176-003, 19-06-226-008 being on the Charter Township of Bloomfield Tax Roll. Said area contains approximately 74.73 acres including the above mentioned public roadway; and is legally described as follows:

Part of "Bloomfield Acres", a subdivision of part of the SW 1/4 of the NW 1/4 of Section 5, as recorded in Liber 41, Page 49, Oakland County Records, and part of the West 1/2 of Section 5, and part of the NE 1/4 of Section 6, T. 2N., R. 10E, Bloomfield Township, Oakland County, Michigan, being more particularly described as commencing at the West 1/4 corner of Section 5, T. 2N., R. 10E; thence N. 01° 51' 17" W., 702.26 feet to the point of beginning; thence N. 50° 14' 30" W., 200.00 feet along the Northerly R.O.W. line of Telegraph Road (204 feet wide); thence N. 39° 45' 30" E., 125.00 feet, thence S. 60° 14' 30" E., 89.66 feet; thence N. 01° 40' 30" W., 767.44 feet along the West line of said "Bloomfield Acres"; thence N. 87° 53' 00" E., 1285.47 feet along the North line of said "Bloomfield Acres"; thence N. 87° 54' 49" E., 1136.23 feet; thence S. 05° 08' 58" E., 1227.51 feet; thence S. 04° 21' 42" E. 427.82 feet to the center of said Section 5; thence S. 88° 13' 20" W., 1019.25 feet along the East and West 1/4 line of said Section 5; thence N. 02° 02' 50" W., 496.39 feet; thence S. 88° 09' 40" W., 258.15 feet; thence N. 71° 03' 18" W., 320.95 feet; thence S. 39° 45' 34" W., 188.74 feet; thence N. 50° 14' 30" W. 353.09 feet; thence S. 39° 45' 34" W., 60.00 feet; thence S. 39°, 45' 34" W., 300.00 feet; thence 50° 14' 30" W., 409.92 feet along the Northerly R.O.W. line of Telegraph Road (204 feet wide) to the point of beginning.

This site contains 3,254,690 s.f. or 74.73 acres including public roadways and contains 3,113,160 s.f. or 71.47 acres excluding public roadways and is subject to any restrictions or easements of record.

EXHIBIT B

Planet Fitness Approved Wall Signage

[Attached]

VILLAGE @ BLOOMFIELD

Pontiac | Bloomfield Twp.

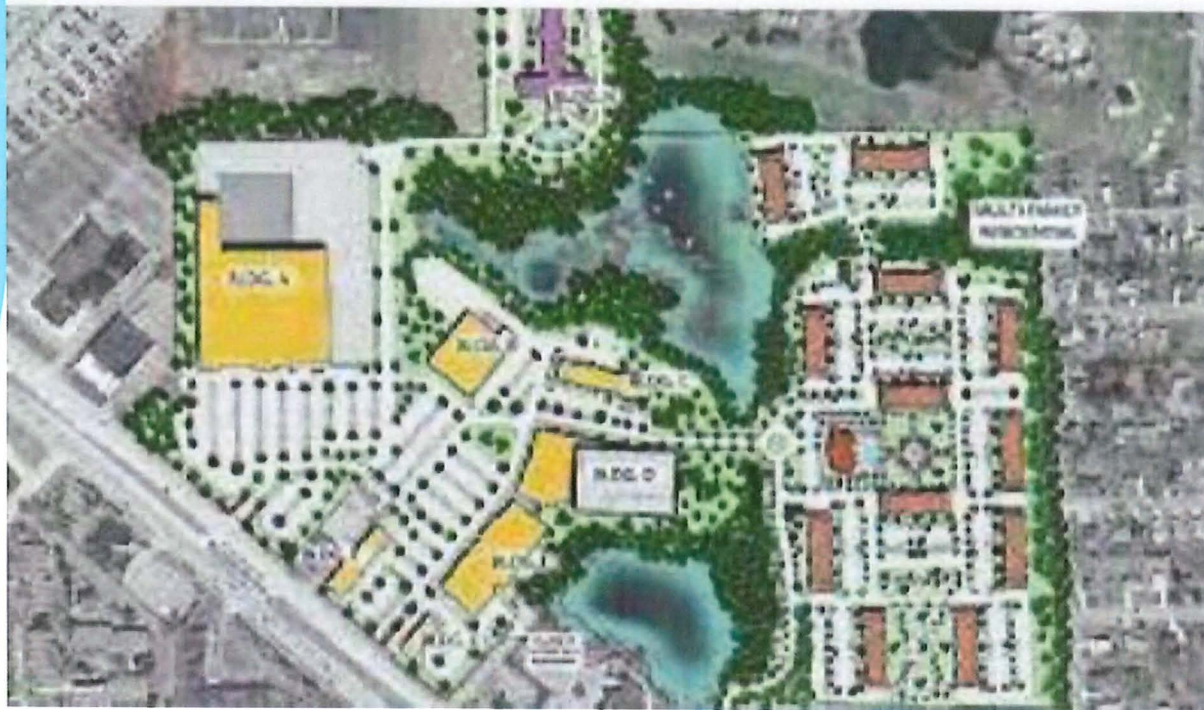

Mayor Deirdre Waterman -
Introduction

Dennis Cowan - JDC, Chair
Historic Overview

Tim McCafferty - REDICO, VP
of Construction
Current Project Development

VILLAGE @ BLOOMFIELD

Pontiac | Bloomfield Twp.

▶ Drone link

▶ <https://vimeo.com/445096175/76e4b82dce>

Bloomfield Park

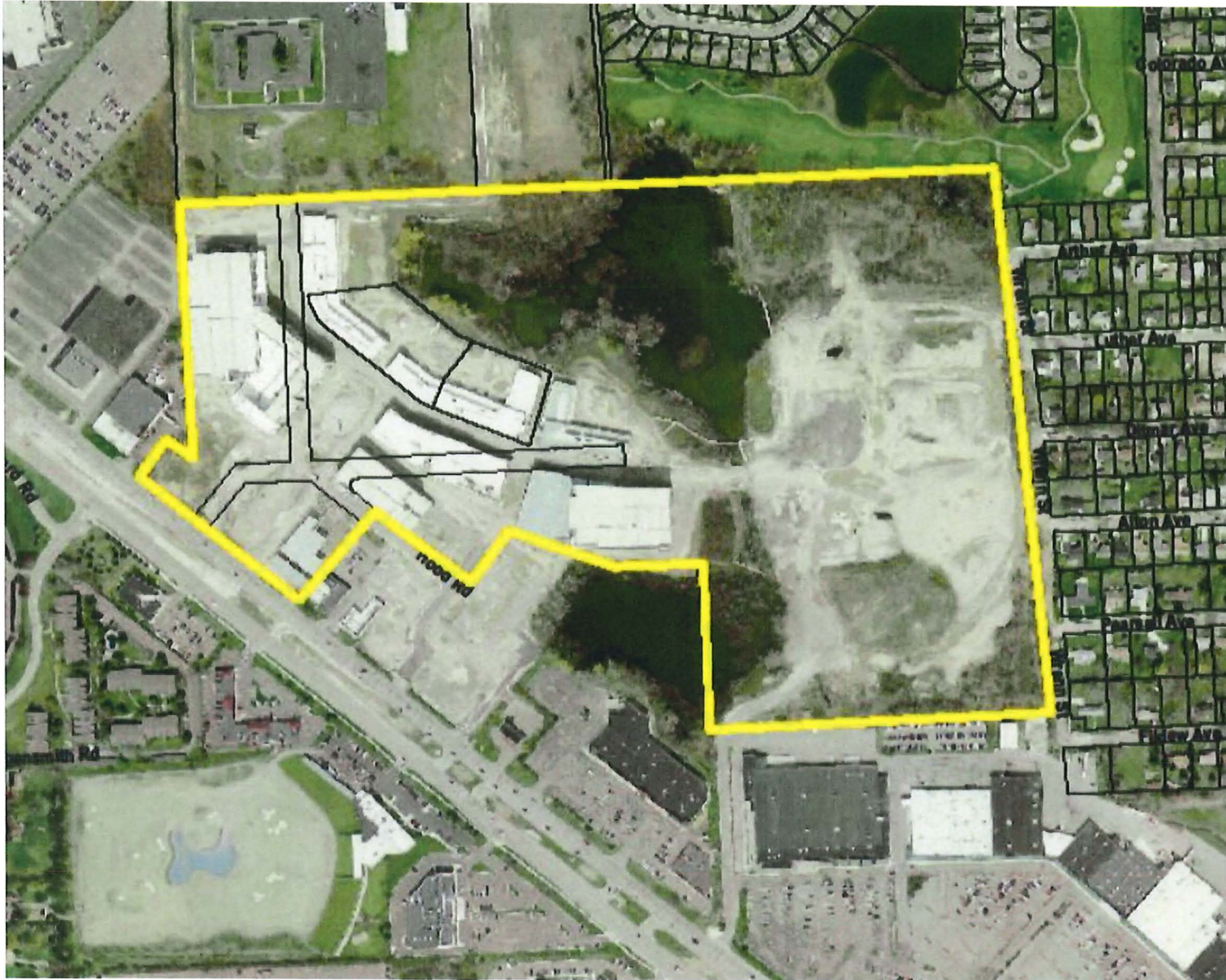

2010 Aerial

Bloomfield Park



An aerial view of Bloomfield Park in 2016.



Bloomfield Park



Village @ Bloomfield



Site
Development
Plan

#12

**COMMUNICATION
FROM THE
CITY CLERK**

October 2020

Medical Marihuana Application Review Status Update

A Process that follows the ordinance as approved by the voters that is fair, transparent and has integrity.

Application Status	Number of Applicants as of September 30, 2020	Review Phase
Grower	7	1 in Phase 1 6 in Phase 3 and 4
Processor	3	2 in Phase 3 and 4 1 in Phase 1
Secure Transporter	1	Application Denied
Safety Compliance	0	
Provisioning – Cesar Chavez	17	17 in Phase 2 and 3
Provisioning – Downtown	23	6 in Phase 2
Provisioning – Non Overlay	48	34 in Phase 1 14 Ready for Phase 2
Provisioning – Walton Blvd	15	Phase 1

Number of New Applications Received:

Grower 1

Processor 1

Accomplishments During the Month of September

1. Grower and Processor Applications have moved to Phase 4.
2. Cesar Chavez Provisioning Center Applications have moved to Phase 3.
3. Some of Downtown Applications have moved to Phase 2.



Office of the City Clerk
Garland S. Doyle
Interim City Clerk
(248) 758-3200

<http://pontiaccityclerk.com/medical-marihuana>

Unresolved Issues

1. The Planning Commission has not made a recommendation to the City Council about the proposed zoning map amendment to allow grower and processor facilities to locate outside of the Walton Blvd and Cesar Chavez Overlay Districts. The text amendment was submitted in January 2020. It has been seven months and still no action by the Planning Commission.

The Clerk will not be able to issue any grower or processor licenses outside of the Walton Blvd. & Cesar Chavez Overlay Districts until Ordinance 2363 the zoning ordinance for Medical Marihuana is amended. Conditional rezoning addresses non-conforming zoning issues. Conditional rezoning does not address the licensing statute in the zoning ordinance. The Clerk is obligated to follow ordinances as they are written. The Clerk will continue to review applications not affected by this issue.

2. The Planning Commission has not made a recommendation to the City Council about the proposed zoning text amendment regarding Hidden River being designated as a park. The text amendment was submitted in August of 2019. It is a year later and still no action by the Planning Commission.

Phases

Type of Review

What happens during the review phase?

Review Phase 1

Content Review

Clerk staff will review application to make sure all information and exhibits have been submitted

Review Phase 2

Default Review

Staff from each department/division checks the applicant name and stakeholders to ensure they are not in default with the city

50th District Court
Review to be completed by City Clerk

Income Tax

Treasury

Code Enforcement

Review Phase 3

Evaluation and/or Scoring Review

Evaluates and/or scores the relevant section of application

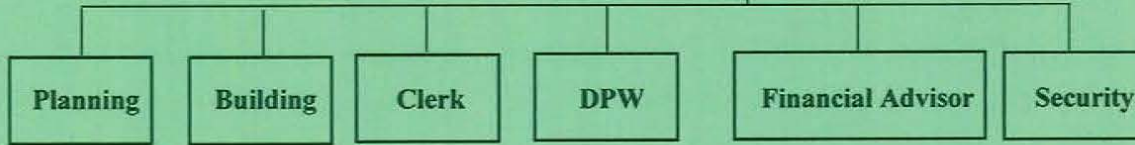

Review Phase 4

Compliance Review

Ensures that standards have been consistently applied by reviews

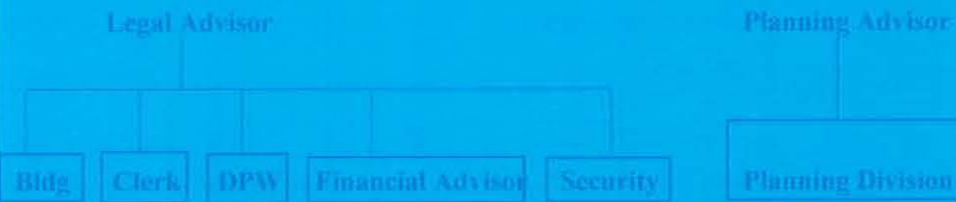

Review Phase 5

Background Check

Review Phase 6

Conditional Approval or Application Denial

If applicant receives conditional approval, they advance to Phase 7

PROCESS FOR APPEAL

Pontiac City Clerk issues denial letter.



Applicant submits written appeal to Pontiac City Clerk within 14 days.



Applicant can present additional clarifying information or evidence that the applicant believes should be considered in assessing its application.



Hearing officer conducts hearing on appeal and makes recommendation to Pontiac City Clerk, who makes a decision on the matter.



Applicant may submit further written appeal to medical marihuana commission within 30 days.

Review Phase 7

Site Plan Approval and/if necessary Special Exemption Approval

Review Phase 8

Certificate of Compliance/Occupancy from Building and Fire

Review Phase 9

Clerk issues a permit provided you have been issued your pre-qualification from the State of Michigan

#13

**COMMUNICATION
FROM THE
MAYOR**

MEMORANDUM

TO: Pontiac City Council
CC: Mayor Deirdre Waterman
FROM: Anthony K. Chubb, Esq.
DATE: September 30, 2020
RE: Forensic Auditor Status Update

Please allow this to serve as a status update regarding negotiations with the Bonadio Group regarding their proposed forensic auditing service contract.

As this Council is well-aware, when contractors perform work for the City, we generally require them to defend the City if claims are made regarding the quality of work they performed for the City. Bonadio has refused to provide any such defense.

Nonetheless, I have been in active negotiation with the Bonadio Group for weeks, and we have exchanged not less than eight versions of the proposed agreement. Although many changes were agreed upon, their last and final proposed version requires the City to “indemnify and hold harmless Bonadio, its employees, partners and third party consultants and subcontractors from any and all direct and third party claims, liabilities, costs, and expenses, including reasonable attorneys’ fees, arising from or relating to the service or deliverables under this letter, except to the extent finally determined to have resulted from the negligence, willful misconduct or fraudulent behavior of Bonadio & Co., LLP.”

The last version that I provided to the Bonadio Group on August 3, 2020 was denied by Bonadio Group, **despite the fact that it is identical to the indemnity provision that they agreed to with Suffolk Community College.** Please see attached provisions of the Suffolk Community College contract. There is no reason that Pontiac should be held treated as a second-class City and held to a different standard.

Again, this in no way prohibits a forensic audit. It simply requires that a contractor perform that work pursuant to a contract that adequately protects the City and its residents.

ATTACHMENT 1

Agreement

This Agreement ("Agreement") is between **Suffolk Community College Association, Inc. ("Association")** and **Suffolk Community College Foundation, Inc. ("Foundation")**, having its principal offices at 533 College Road, Selden, New York 11784, and

Bonadio & Co., LLP ("Contractor"), a New York limited liability company licensed to do business in the State of New York, having its principal place of business at 6 Wembley Court, Albany, New York 12205.

The parties hereto desire to have Contractor to provide accounting and auditing services for the Association and the Foundation ("Services").

Term of Agreement: September 1, 2015 through August 31, 2016, with four (4) one year options to renew at the sole discretion of the Association and Foundation.

Total Cost of Agreement: Not to exceed \$12,000.00 for the Association; as set forth in Exhibit E, attached, and not to exceed \$19,000.00 for the Foundation, as set forth in Exhibit E, attached.

Terms and Conditions: Shall be as set forth in Exhibits A through F attached hereto and made a part hereof.

In Witness Whereof, the parties hereto have executed this Agreement as of the latest date written below.

Bonadio & Co., LLP
Fed. Tax ID #16-1131146

Suffolk Community College Association, Inc.

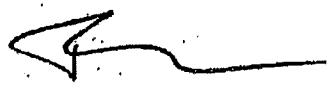
By: 

Timothy J. Doyle, CPA
Partner

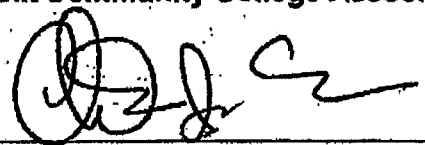
By: 

Dr. Christopher J. Adams
Vice President of Student Affairs

Date: _____

Date: 9/10/15

Approved as to Legality:

Suffolk Community College Foundation, Inc.

By: 

Louis J. Petrizzo
College General Counsel

By: 

Dr. Sylvia A. Diaz
Executive Director

Date: 09/11/15

Date: 9/10/15

Association and Foundation shall pay Contractor for the services rendered through the date of termination.

f. Payments upon Termination

- i.** Upon receiving a Termination Notice, Contractor shall promptly discontinue all services affected unless otherwise directed by the Termination Notice.
- ii.** The Association and Foundation shall be released from any and all responsibilities and obligations arising from the services provided in accordance with by this Agreement, effective as of the date of termination, but the Association and Foundation shall be responsible for payment of all claims for services provided and costs incurred by Contractor prior to termination of this Agreement, that are pursuant to, and after Contractor's compliance with, the terms and conditions of this Agreement.
- iii.** Upon termination, Contractor agrees to promptly reimburse to the Association and Foundation the balance of any funds advanced to Contractor by the Association and Foundation. Upon termination, any funds paid to Contractor by the Association and Foundation which were used by Contractor in a manner that failed to comply with the terms and conditions of this Agreement must be promptly reimbursed. If there is no response or if satisfactory repayments are not made, the Association and Foundation may recoup such payments from any amounts due or becoming due to Contractor from the Association and Foundation under this Agreement or otherwise. The provisions of this subparagraph shall survive the expiration or termination of the Agreement.

3. Indemnification

a. General

Contractor agrees that it shall protect, indemnify and hold harmless the Association and Foundation and/or Suffolk County Community College and/or County of Suffolk and their officers, officials, employees, contractors, agents and other persons from and against all liabilities, fines, penalties, actions, damages, claims, demands, judgments, losses, costs, expenses, suits or actions and reasonable attorneys' fees, arising out of the acts or omissions or the negligence of Contractor in connection with the services described or referred to in this Agreement. Contractor shall defend the Association and Foundation and /or County and their officers, officials, employees, contractors, agents and other persons in any suit, including appeals, or at the Association and Foundation and /or County's option, pay reasonable attorney's fees for defense of any such suit arising out of the acts or omissions or negligence of Contractor, its officers, officials, employees, subcontractors or agents, if any, in connection with the services described or referred to in this Agreement.

#14

**Mayoral
Monthly
Report**



**CITY OF PONTIAC
FINANCE DEPARTMENT
HUMAN RESOURCES DIVISION
47450 Woodward Avenue
Pontiac, Michigan 48342**

TO: Honorable Mayor, Council President, and City Council Members
FROM: Kiearha Davidson, Human Resources Manager
DATE: September 29, 2020
RE: September New Hire Report

Name	Hire Date	Job Title	Department
Rami Sweidan	09/08/20	Code Enforcement Officer	Planning & Code Enforcement
Mathew Berens	09/14/20	Code Enforcement Officer	Planning & Code Enforcement
Abdul Siddiqui	09/16/20	Engineers	Public Works
Porche Prater	09/23/20	Deputy Treasurer	Treasury

#15

**Mayoral
Monthly
Report**

8-21-20

Check Register

Check Date	Check	Vendor	Vendor Name	Invoice Number	Amount	Status
------------	-------	--------	-------------	----------------	--------	--------

Bank CONS CONSOLIDATED

Check Type: EFT Transfer

08/21/2020	753 (E)	10004301	PNC Bank	19419	372.50	Open
				513597807-001	75.24	Open
				06-03700	259.32	Open
				2218239680	747.13	Open
				2218247964	503.48	Open
				77671	258.00	Open
				63591-5	189.60	Open
				July 3rd, 2020	216.00	Open
				6-24-20	280.00	Open
				7-21-20	435.99	Open
				A2D58EDF-003	37.00	Open
				1713383427	159.98	Open
				7-31-20 Ck#126	159.40	Open
				56495	59.00	Open
				1999859505	(57.21)	Open
				492191227-001Cr	(28.97)	Open
				1713383427credit	(159.98)	Open
				Order# 739165 refund	(76.91)	Open
					<u>3,429.57</u>	
				Total EFT Transfer:	<u>3,429.57</u>	

Check Type: Paper Check

08/19/2020	528159	10003889	Oakland County Register of Deeds	2020-0819BOAMeeting	210.00	Open
				Total Paper Check:	<u>210.00</u>	

CONS TOTALS:

Total of 2 Checks:					3,639.57	
Less 0 Void Checks:					0.00	
Total of 2 Disbursements:					<u>3,639.57</u>	

Bank COURT FIFTH THIRD-COURT OPERATING

Check Type: Paper Check

08/21/2020	8218	00000050	AT & T	248857950108	36.71	Open
08/21/2020	8219	10004373	Barbara Jill Palulian	CER#7294	250.00	Open
08/21/2020	8220	00001244	Comcast Cablevision	8529101461030042	104.85	Open
08/21/2020	8221	10000511	DATA LEGAL	26020	720.34	Open
08/21/2020	8222	10001025	JOHNSON CONTROLS SECURITY SOLUTIONS	34667165	1,646.35	Open
08/21/2020	8223	10003909	Maria Fabiana Valy Gialdi	200986SM I	70.00	Open
				200495OM I	78.75	Open
				200986SM I	70.00	Open
				201098SM I	70.00	Open
				200706FY I	70.00	Open
				200969FY I	70.00	Open

Check Date	Check	Vendor	Vendor Name	Invoice Number	Amount	Status
					428.75	
08/21/2020	8224	00002244	OFFICE DEPOT	108601673002	3.68	Open
				108601673001	238.38	Open
					242.06	
08/21/2020	8225	00002483	ROSE PEST SOLUTIONS	30880088	50.00	Open
08/21/2020	8226	10004185	Shari Morton	113 CER#6722	150.00	Open
08/21/2020	8227	00010900	Shred-It USA LLC	8180250998	625.43	Open
				Total Paper Check:	4,254.49	
COURT TOTALS:						
Total of 10 Checks:					4,254.49	
Less 0 Void Checks:					0.00	
Total of 10 Disbursements:					4,254.49	
REPORT TOTALS:						
Total of 12 Checks:					7,894.06	
Less 0 Void Checks:					0.00	
Total of 12 Disbursements:					7,894.06	

8-28-20

Check Register

User: JPETERS
 DB: Pontiac

Check Date	Check	Vendor	Vendor Name	Invoice Number	Amount	Status
Bank CONS CONSOLIDATED						
Check Type: EFT Transfer						
08/27/2020	745 (E)	00000603	Oakland County Treasurer	2020-0815County	1,360,010.30	Open
08/27/2020	746 (E)	10003903	Pontiac Public Library	2020-0815Library	89,377.65	Open
08/27/2020	747 (E)	00012890	Pontiac Schools	2020-0815MESSA	44,160.93	Open
08/27/2020	748 (E)	00012890	Pontiac Schools	2020-0815Operating	1,237,673.86	Open
08/27/2020	749 (E)	00012890	Pontiac Schools	2020-0815Sinking	301,361.48	Open
08/28/2020	750 (E)	10004232	Level One Bank	August 2020	1,800,000.00	Open
08/28/2020	751 (E)	00000603	Oakland County Treasurer	8/28/20 Investment	1,500,000.00	Open
08/28/2020	752 (E)	10003750	WMHIP-W Michigan Health 8890	September 2020	35,454.80	Open
Total EFT Transfer:					<u>6,368,039.02</u>	
Check Type: Paper Check						
08/26/2020	528160	10004313	ADT Commercial LLC	135741946	49.95	Open
08/26/2020	528161	10004305	Ameena Razia Sheikh	20-02-19 200126SM	40.00	Open
				20-05-20 200677SM	20.00	Open
				20-06-14 190S29322A	20.00	Open
				20-06-14 191533SM	20.00	Open
				20-06-18 191533SM	150.00	Open
				20-06-18 200808SM	300.00	Open
				20-06-18 190S29322A	50.00	Open
				20-06-18 200126SM	40.00	Open
				20-06-29 200395SM	50.00	Open
				20-06-29 140S16900A	100.00	Open
				20-07-07 08058457X	50.00	Open
				20-07-17 1873367SM	20.00	Open
				20-07-20 200951SM	20.00	Open
				20-07-20 040889504X	50.00	Open
				20-07-21 AM	200.00	Open
				20-07-26 11E336975A	20.00	Open
				2020-07-28 AM	200.00	Open
				20-08-03 180S23759C	50.00	Open
				20-08-03 040S89504X	50.00	Open
				20-08-03 100S07358A	50.00	Open
				20-08-04 AM	200.00	Open
					<u>1,700.00</u>	
08/26/2020	528162	10004322	Animal Xtractors	000707	300.00	Open
08/26/2020	528163	10004022	Arbor Oakland Group	113788	53.21	Open
08/26/2020	528164	00000050	AT & T	8310007501007-0820	1,294.90	Open
				8310007527298-0820	221.00	Open
					<u>1,515.90</u>	
08/26/2020	528165	00000050	AT & T	248253002608-20	612.53	Open
08/26/2020	528166	00000050	AT & T	250472140-080820	84.61	Open
08/26/2020	528167	10003274	AT & T Long Distance	821555420-080420	22.03	Open
08/26/2020	528168	10004207	Belem Morales Law Office	20-07-16 AM	200.00	Open
				20-07-13 BB	8.00	Open
				20-07-13 FM	20.00	Open
				20-07-13 GP	17.00	Open
				20-07-13 LD	8.00	Open

Check Date	Check	Vendor	Vendor Name	Invoice Number	Amount	Status
				20-07-27 JW	8.00	Open
				20-07-30 AM	250.00	Open
				20-08-04 AM	300.00	Open
					<u>811.00</u>	
08/26/2020	528169	00001103	Blue Cross Blue Shield of Michigan	60418-600-0920	65,571.44	Open
				60418-601-0920	12,985.08	Open
				60418-602-0920	40,431.36	Open
				60418-604-0920	5,099.85	Open
				60418-605-090120	9,700.70	Open
					<u>133,788.43</u>	
08/26/2020	528170	00001103	Blue Cross Blue Shield of Michigan	7036880-0004-0901	11,828.93	Open
				7036880-0005-0920	6,685.83	Open
				7036880-0006-0920	178,497.07	Open
				7036880-0007-0920	13,588.98	Open
				7045068-0000-0920	13,855.65	Open
				7045068-0002-0920	1,917.62	Open
					<u>226,374.08</u>	
08/26/2020	528171	00001156	C&S Motors, Inc.	FS83396	8,876.04	Open
08/26/2020	528172	00010597	Charesa D. Johnson	20-07-13 09-125210CO	8.00	Open
				20-07-13 19-009700M	68.00	Open
				20-07-22 190S39718A	193.00	Open
					<u>269.00</u>	
08/26/2020	528173	10004429	Cleannet of Greater Michigan	DET0086523	1,625.31	Open
				DET0086956	1,625.31	Open
				DET0086524	975.19	Open
				DET0086957	975.19	Open
					<u>5,201.00</u>	
08/26/2020	528174	00001244	Comcast Cablevision	825-903542484-0820	334.18	Open
				6180-214665-0820CR	(173.84)	Open
					<u>160.34</u>	
08/26/2020	528175	00001244	Comcast Cablevision	110-1037575-0820	174.91	Open
				825-946958-0820	324.45	Open
				6180-214665-0820	181.80	Open
				47450-862478-0820	125.44	Open
					<u>806.60</u>	
08/26/2020	528176	00000206	Consumers Energy	10-95261074-0820	14.00	Open
				52-96422630-0820	81.86	Open
				70-96511412-0820	123.16	Open
				110-98711686-0820	106.13	Open
				216-97012165-0820	21.77	Open
				350-96873280-0820	24.76	Open
				825-97397342-0820	14.00	Open
				990-96288609-0820	83.40	Open
				47450-96189951-0820	125.23	Open
					<u>125.23</u>	

09/03/2020 03:42 PM
 User: JPETERS
 DB: Pontiac

CHECK REGISTER FOR CITY OF PONTIAC
 CHECK DATE FROM 08/22/2020 - 08/28/2020

Check Date	Check	Vendor	Vendor Name	Invoice Number	Amount	Status
					594.31	
08/26/2020	528177	10004348	Cory Westmoreland	2020-07-20 200514SM 20-07-29 AM 20-07-29 AM	250.00 100.00 100.00	Open Open Open
					<u>450.00</u>	
08/26/2020	528178	10004156	Covenant Cemetery Services, Inc.	51026-R 60336-R	1,000.00 2,500.00	Open Open
					<u>3,500.00</u>	
08/26/2020	528179	10004243	Creative Schools Management, LLC	September 2020	26,000.00	Open
08/26/2020	528180	10000127	Delta Dental of Michigan	RIS0003014482	1,094.18	Open
08/26/2020	528181	10004383	Dennis Thompson	6/18/20	17.00	Open
08/26/2020	528182	00000247	DTE Energy	60-8830604-0720 910040679979-0720	14,126.96 76,649.43	Open Open
					<u>90,776.39</u>	
08/26/2020	528183	00000247	DTE Energy	52-7080527-0720 70-4941404-0720 216-7484267-0720 435-7849547-0720 440-2777841-0720 786-2776558-0720 827-5543457-0720 827-7082417-0720 990-7078596-0720 6180-5436439-0720 6180-5436464-0720	798.08 6,523.88 26.64 63.68 381.09 25.89 102.31 989.67 476.17 137.24 388.31	Open Open Open Open Open Open Open Open Open Open Open
					<u>9,912.96</u>	
08/26/2020	528184	10004332	Edith Blakney Law Firm, PLLC	20-06-20 200719SM 20-08-02 06b257262Y 20-08-05 18OS25403A 20-08-05 AM	50.00 100.00 20.00 100.00	Open Open Open Open
					<u>270.00</u>	
08/26/2020	528185	10004306	Erika D. Morgan Law, PLLC	20-06-25 110S16174C	25.00	Open
08/26/2020	528186	10004088	Fidelity Security Life Insurance Co	164471804 164471432 164472330	365.42 151.08 186.90	Open Open Open
					<u>703.40</u>	
08/26/2020	528187	00001526	Gabriel, Roeder, Smith & Co	452069 456545	2,700.00 2,700.00	Open Open
					<u>5,400.00</u>	
08/26/2020	528188	00000436	Gracey Law Firm, PLLC	20-03-02 191364SM 20-05-06 200265OM 20-06-19 191364SM	75.00 25.00 100.00	Open Open Open

Check Date	Check	Vendor	Vendor Name	Invoice Number	Amount	Status
				20-06-19 2002680M	25.00	Open
				20-05-22 1917270M	20.00	Open
					<u>245.00</u>	
08/26/2020	528189	10000009	Great Lakes Auto Superstore LLC	September 2020	5,833.33	Open
				JulyUtil pd Sept	1,405.09	Open
					<u>7,238.42</u>	
08/26/2020	528190	10003261	Hillarie F. Boettger, PLLC	20-07-19 2002780M	80.00	Open
08/26/2020	528191	10004337	Idumesaro Law Firm, PLLC	20-07-06 190S03446A	17.00	Open
				20-07-04 2004030M	33.00	Open
				20-07-14 200S09722A	42.00	Open
				20-07-16 190S13001B	17.00	Open
				20-07-28 2004450M	117.00	Open
				20-07-24 141367800M	33.00	Open
				20-07-26 1905090M	18.00	Open
				20-07-27 170S21302A	17.00	Open
				20-07-27-190S043446A	43.00	Open
				20-07-27 AM	262.00	Open
				20-07-28 2003520M	182.00	Open
				20-07-28 2004450M	123.00	Open
				20-08-03 AM	220.00	Open
				20-08-05 170S19155A	62.00	Open
				20-08-05 180S00430A	40.00	Open
				20-08-05 190S08287A	20.00	Open
				20-08-05 AM	158.00	Open
					<u>1,404.00</u>	
08/26/2020	528192	00013088	Innovative Software Services, Inc. 2333		17,466.78	Open
08/26/2020	528193	10000960	Iron Mountain Incorporated	202181747	321.23	Open
				CVPW618	293.08	Open
				CVPW619	248.37	Open
				CVPW623	368.44	Open
					<u>1,231.12</u>	
08/26/2020	528194	10003866	K and Q Law, PC	20-02-16 17-1444790M	75.00	Open
				20-05-27 200S02888A	50.00	Open
				20-06-23 190S40288B	45.00	Open
				20-06-17 180S40820A	25.00	Open
				20-06-22 180S40820A	25.00	Open
				20-06-23 19-0540288B	50.00	Open
				20-06-24 120S07601A	33.00	Open
				20-06-24 140S14252A	17.00	Open
				20-06-24 170S22127B	75.00	Open
				20-06-29 190S281980T	25.00	Open
				20-06-29 AM	225.00	Open
				20-07-02 19-0754SM	100.00	Open
				20-07-17 18-1488210M	50.00	Open
				20-07-29 AM	150.00	Open
					<u>945.00</u>	
08/26/2020	528195	10003942	Law Office of D Ann Parker, PC	20-04-28 200025SM	50.00	Open
				20-05-13 200609SM	100.00	Open
				20-06-23 20-652SM	100.00	Open

Check Date	Check	Vendor	Vendor Name	Invoice Number	Amount	Status
				20-07-22 AM	300.00	Open
					550.00	
08/26/2020	528196	10004388	Law Office of Christophen R Shemke	20-07-29 AM	200.00	Open
08/26/2020	528197	10002474	Law offices of Moneka L. Sanford	PI20-05-11 2001520M	100.00	Open
				20-05-18 2001520M N	150.00	Open
				20-05-22 180S28651B	50.00	Open
				20-05-25 191663SM	20.00	Open
				20-05-26 180S28651B	150.00	Open
				20-06-04 200516SM	20.00	Open
				20-06-14 200S04885A	100.00	Open
				20-07-20 200219OM	220.00	Open
				20-07-20 200219-OM	200.00	Open
					1,010.00	
08/26/2020	528198	00012690	Law Offices of Paulette Michel,	PLI20-06-30 AM	100.00	Open
				20-08-13 AM	150.00	Open
					250.00	
08/26/2020	528199	00010223	Lisa C Watkins Law Office	20-02-28 20-0253SM	50.00	Open
				20-03-06 19-1518SM	33.00	Open
				20-5-27 20-0613SM	50.00	Open
				20-06-09 20-0766SM	50.00	Open
				20-06-12 19-1413SM	50.00	Open
				20-06-11 20-0503SM	42.00	Open
				20-06-15 20-0615SM	33.00	Open
				20-06-16 20-0613SM	225.00	Open
				20-06-23 20-0253SM	708.00	Open
				20-06-23 19-1518SM	400.00	Open
				20-06-30 18-733765SD	100.00	Open
					1,741.00	
08/26/2020	528200	00012978	Meadowbrook, Inc.	5183	3,757.00	Open
08/26/2020	528201	00010549	Mutual of Omaha Insurance Company	1115635108	8,579.82	Open
08/26/2020	528202	10004329	Nachawati Law, PLLC	20-07-17 190S27196B	17.00	Open
				20-07-17 14-66588SD	20.00	Open
				20-07-17 19-1652SM	13.00	Open
				20-07-23 20-0958SM	13.00	Open
				20-07-23 KW	22.00	Open
				20-07-24 190353SM	10.00	Open
				20-07-24 190707OD	10.00	Open
				20-07-20 191825OM	10.00	Open
				20-07-28 AM	183.00	Open
				20-07-01 AM	400.00	Open
					698.00	
08/26/2020	528203	00002197	Nowak & Fraus, PLLC	104575	14,815.25	Open
08/26/2020	528204	10004389	Rucker & Associates, P.C.	20-06-23 200746SM	50.00	Open
08/26/2020	528205	00013067	Scott C. Kozak, Attorney at Law	20-05-07 20-0599SM	50.00	Open
				20-07-08 1872623SM	75.00	Open
				20-07-08 200S01175	100.00	Open
				20-06-30 191462SM	150.00	Open
				20-07-24 20-0359OM	25.00	Open
				20-07-24 200S12323	17.00	Open

CHECK REGISTER FOR CITY OF PONTIAC
 CHECK DATE FROM 08/22/2020 - 08/28/2020

Check Date	Check	Vendor	Vendor Name	Invoice Number	Amount	Status
				20-07-27 200S12307	25.00	Open
				20-07-29 AM	100.00	Open
					<u>542.00</u>	
08/26/2020	528206	10004173	Seasonal Property Maintenance LLC	2036	1,500.00	Open
08/26/2020	528207	10004230	Solomon P Marve Sr.	7/11-25/20	131.25	Open
08/26/2020	528208	00013050	Stacy A. Drouillard	20-04-13 200132SM	25.00	Open
				20-07-02 160S36930B	25.00	Open
				20-07-06 2004670M	33.00	Open
				20-07-10 200S12174A	17.00	Open
				20-07-07 2004120M	17.00	Open
				20-07-20 2003300M	25.00	Open
				20-07-21 130S12167A	22.00	Open
				20-07-21 2005200M	17.00	Open
				20-07-21 05115699CO	30.00	Open
				20-07-21 161432090M	30.00	Open
				20-07-19 110088757B	12.00	Open
				20-07-23 130S24899A	13.00	Open
				20-07-27 120S00376B	25.00	Open
				20-07-27 180S03751A	25.00	Open
				20-07-27 200S12076B	25.00	Open
				20-07-27 200S12966B	53.00	Open
				20-07-27 2003400M	25.00	Open
				20-07-29 AM	190.00	Open
				20-07-29 180S43744A	27.00	Open
				20-07-29 2004120M	42.00	Open
				20-07-29 13201379Y	38.00	Open
				20-07-29 11474400M	25.00	Open
				20-08-05 160S30201A	25.00	Open
				20-08-05 170S15120B	133.00	Open
				20-08-05 200S1652A	42.00	Open
					<u>941.00</u>	
08/26/2020	528209	00002625	State Of Mich/Mgmt & Budget	MIDEAL-461 2020	270.00	Open
08/26/2020	528210	10003813	Water Resource Commissioner	440-80918-08-0720	341.43	Open
				440-80919-02-0720	98.86	Open
				990-78699-00-0720	411.70	Open
				52-69413-00-0820	213.20	Open
				825-80806-02-0820	2,829.75	Open
				786-80882-09-0820	341.12	Open
				47450-81007-00-0820	3,725.74	Open
					<u>7,961.80</u>	
08/26/2020	528211	10004330	Wilkerson Law, PLLC	20-05-08 180S41886A	75.00	Open
				20-05-15 200S06478A	117.00	Open
				20-05-15 1919910M	50.00	Open
				20-05-18 AM	150.00	Open
				20-06-29 1568754SM	20.00	Open
				20-07-01 140S19154A	50.00	Open
				20-07-01 160S04181A	25.00	Open
				20-07-08 AM	150.00	Open
				20-06-23 190S19796B	50.00	Open
				20-07-10 200893SM	33.00	Open
				20-07-10 1059956SM	50.00	Open
				20-07-10 1872998SM	20.00	Open
				20-07-14 AM	150.00	Open

09/03/2020 03:42 PM
User: JPETERS
DB: Pontiac

CHECK REGISTER FOR CITY OF PONTIAC
CHECK DATE FROM 08/22/2020 - 08/28/2020

Page: 7/7

Check Date	Check	Vendor	Vendor Name	Invoice Number	Amount	Status
				20-07-28 191596SM	100.00	Open
					<u>1,040.00</u>	
				Total Paper Check:	<u>592,015.40</u>	

CONS TOTALS:

Total of 60 Checks:	6,960,054.42
Less 0 Void Checks:	<u>0.00</u>
Total of 60 Disbursements:	<u>6,960,054.42</u>

Bank COURT FIFTH THIRD-COURT OPERATING

Check Type: Paper Check

08/24/2020	8228	10002889	50th District Court	08/18/2020 BOND	71.00	Open
				Total Paper Check:	<u>71.00</u>	

COURT TOTALS:

Total of 1 Checks:	71.00
Less 0 Void Checks:	<u>0.00</u>
Total of 1 Disbursements:	<u>71.00</u>

Bank PNCMM PNC MONEY MARKET

Check Type: EFT Transfer

08/27/2020	152(E)	00013053	City of Pontiac	2020-0815City	1,770,597.68	Open
				Total EFT Transfer:	<u>1,770,597.68</u>	

PNCMM TOTALS:

Total of 1 Checks:	1,770,597.68
Less 0 Void Checks:	<u>0.00</u>
Total of 1 Disbursements:	<u>1,770,597.68</u>

REPORT TOTALS:

Total of 62 Checks:	8,730,723.10
Less 0 Void Checks:	<u>0.00</u>
Total of 62 Disbursements:	<u>8,730,723.10</u>

9-11-20

Check Register

09/14/2020 03:04 PM
 User: JPETERS
 DB: Pontiac

CHECK REGISTER FOR CITY OF PONTIAC
 CHECK DATE FROM 09/05/2020 - 09/11/2020

Check Date	Check	Vendor	Vendor Name	Invoice Number	Amount	Status
Bank BOND FIFTH THIRD BOND ACCOUNT						
Check Type: Paper Check						
09/11/2020	12968	10002889	50th District Court	180S41105B A	150.00	Open
				190S32081A F	250.00	Open
				1902150M A	480.00	Open
				1905060M A	500.00	Open
				200915FY 10%	500.00	Open
				200374FY 10%	25.00	Open
				200374FY A	225.00	Open
				180S32645A 10%	25.00	Open
				200S00089A F	250.00	Open
				200S00089B F	220.00	Open
				200394SM 10%	25.00	Open
				200624FY F	250.00	Open
				190334SM A	1,670.00	Open
				201128SM A	225.00	Open
				201128SM 10%	25.00	Open
				200S02888C 10%	7.50	Open
				200S02888C A	67.50	Open
				200482FY 10%	20.00	Open
				200482FY A	180.00	Open
				2006130M A	50.00	Open
				180S16721C A	154.00	Open
				180S16721E A	282.00	Open
					<u>5,581.00</u>	
09/11/2020	12969	BOND	ANTHONEY JACKSON	11X293715A R	3.00	Open
09/11/2020	12970	BOND	BARBARA GREGORY	X2915251B R	106.00	Open
09/11/2020	12971	BOND	BRANDI RASCH	200915FY R	4,500.00	Open
09/11/2020	12972	BOND	CHRISTOPHER CISNEROS	2002770M R	250.00	Open
09/11/2020	12973	BOND	DESHAWN CONLEY	180S05714B R	350.00	Open
				180S05714A R	350.00	Open
					<u>700.00</u>	
09/11/2020	12974	BOND	DEVON EARL METOYER	190S22195A R	43.00	Open
09/11/2020	12975	BOND	DOMONICK DIMITRICK WASHINGTON	200S03249E R	46.00	Open
09/11/2020	12976	BOND	ELLA DOSS	11X293715A R	45.00	Open
09/11/2020	12977	BOND	FREDERICK JENKINS	160S29680A R	45.00	Open
				160S34087A R	45.00	Open
					<u>90.00</u>	
09/11/2020	12978	BOND	JAMES ANTHONY HILLS	200S12559A R	7.00	Open
09/11/2020	12979	BOND	JORDAN DRINNON	1902150M R	20.00	Open
09/11/2020	12980	BOND	JUAN LUIS ORTIZ-VEGA	1873500SM R	5.00	Open
09/11/2020	12981	BOND	KENYA HILLIE	180S32645A R	225.00	Open
09/11/2020	12982	BOND	MARCO TULLIO LIMA	200394SM R	225.00	Open
09/11/2020	12983	BOND	NAJEEBAH SWIYYAH TANZIL	190334SM R	3,330.00	Open
09/11/2020	12984	00002208	OAKLAND COUNTY CLERK	200164FY C	250.00	Open
				200802FY C	500.00	Open
				201072FY C	250.00	Open
				201138FY C	250.00	Open
				191621FY C	1,000.00	Open

Check Date	Check	Vendor	Vendor Name	Invoice Number	Amount	Status
				201092FY C	250.00	Open
				200491FY C	250.00	Open
				201139FY C	250.00	Open
					<u>3,000.00</u>	
09/11/2020	12985	BOND	OMARI VINNING	200769SD R	140.00	Open
09/11/2020	12986	BOND	RAYMOND CORKINS	191050SMR	175.00	Open
09/11/2020	12987	BOND	RENAE MCGEE	200613OM R	50.00	Open
09/11/2020	12988	BOND	SHARI LOIS HAMILTON	190S11044B R	45.00	Open
				Total Paper Check:	<u>18,586.00</u>	
BOND TOTALS:						
				Total of 21 Checks:	18,586.00	
				Less 0 Void Checks:	0.00	
				Total of 21 Disbursements:	<u>18,586.00</u>	
Bank CONS CONSOLIDATED						
Check Type: EFT Transfer						
09/09/2020	754 (E)	10004293	North Bay Drywall, Inc	Sept 2020 electric	4,409.35	Open
09/09/2020	755 (E)	00002316	Pitney Bowes Inc	Postage 9-9-20	20,000.00	Open
				Total EFT Transfer:	<u>24,409.35</u>	
Check Type: Paper Check						
09/11/2020	528311	10002840	21st Century Media Newspapers, LLC AD#1986493		428.50	Open
09/11/2020	528312	10003843	Advanced Disposal Services	PT0000028957	73.71	Open
				PT0000029014	6.25	Open
				PT0000028873	610.93	Open
				PT0000028874	163.43	Open
				PT0000028915	681.65	Open
				PT0000029013	2.98	Open
				PT0000029057	0.89	Open
				V20002419127	215,573.57	Open
					<u>217,113.41</u>	
09/11/2020	528313	10003733	Alliance Payment Solutions, Inc	318333	731.87	Open
09/11/2020	528314	10003879	Amazon.com LLC	1DNJ-9FKT-JRPF	255.55	Open
09/11/2020	528315	10004305	Ameena Razia Sheikh	7/19/20 200879SM	20.00	Open
				7/22/20 10A257713A	50.00	Open
				7/27/20 19OS38399B	20.00	Open
				8/5/20 20OS13818A	20.00	Open
				8/6/20 1872594FY	50.00	Open
				8/6/20 AM	100.00	Open
				8/11/20 AM	200.00	Open
				7/28/20 1872594FY-M	50.00	Open
					<u>510.00</u>	
09/11/2020	528316	00000050	AT & T	80025874118-0920	1,725.23	Open
				8310005335294-0820	2,231.30	Open

Check Date	Check	Vendor	Vendor Name	Invoice Number	Amount	Status
				8310005335298-0820	1,918.12	Open
					<u>5,874.65</u>	
09/11/2020	528317	00000050	AT & T	287269014755x81720	1,228.26	Open
09/11/2020	528318	10004207	Belem Morales Law Office	6/29/20 JS-Walker	8.00	Open
				7/27/20 CR-Walker	5.00	Open
				7/27/20 CS-Walker	17.00	Open
				8/3/20 CM-Walker	17.00	Open
				8/3/20 SR-Walker	17.00	Open
				8/10/20 AM Sentencin	75.00	Open
				8/11/20 AM	325.00	Open
					<u>464.00</u>	
09/11/2020	528319	00001156	C&S Motors, Inc.	FP198775	1,348.52	Open
				FP198791	234.54	Open
					<u>1,583.06</u>	
09/11/2020	528320	00010597	Charesa D. Johnson	6/19/20 20-01820T	172.00	Open
				7/28/20 20-03880M	275.00	Open
					<u>447.00</u>	
09/11/2020	528321	10003346	City of Auburn Hills	71000518575-0920	19,634.21	Open
09/11/2020	528322	10003968	City of Rochester Hills	39918	1,726.52	Open
09/11/2020	528323	00001244	Comcast Cablevision	990-1024326-0920	425.56	Open
				990-878763-0920	354.53	Open
				52-1022718-0920	425.56	Open
					<u>1,205.65</u>	
09/11/2020	528324	00000206	Consumers Energy	216-97012719-0820	30.14	Open
				6180-96321407-0820	14.60	Open
				216-97012719-0820Cr	(30.14)	Open
					<u>14.60</u>	
09/11/2020	528325	00001267	Contractors Connection	7145217	227.45	Open
09/11/2020	528326	10004348	Cory Westmoreland	6/15/20 181478600M	100.00	Open
				6/22/20 200S08910A	17.00	Open
				6/23/20 150S18914b	50.00	Open
				6/23/20 190S3842A	17.00	Open
				6/23/20 2000500M	17.00	Open
				7/14/20 200656SM	450.00	Open
				8/7/20 05b225334Y	100.00	Open
				8/7/20 170S08594A	33.00	Open
				8/7/20 180S26817A	50.00	Open
				8/7/20 190S11044B	50.00	Open
				8/7/20 2002000M	75.00	Open
				8/7/20 171458460M	67.00	Open
				8/10/20 AM	175.00	Open
				8/13/20 180S32645A	43.00	Open
				8/13/20 200S13884A	42.00	Open
				8/13/20 1920500M	20.00	Open
					<u>1,306.00</u>	

Check Date	Check	Vendor	Vendor Name	Invoice Number	Amount	Status
				20-7-23 18OS31390B	33.00	Open
				20-7-30 AM	100.00	Open
				20-8-2 19-OS36109B	100.00	Open
				20-8-13 AM	100.00	Open
					<u>915.00</u>	
09/11/2020	528339	00001591	Guardian Alarm Company of Michigan	21061034	140.96	Open
09/11/2020	528340	10003261	Hillarie F. Boettger, PLLC	20-7-16 04b260079	20.00	Open
				20-7-16 AM	100.00	Open
				20-7-19 12OS26804A	20.00	Open
				20-7-19 2000600T	20.00	Open
				20-7-26 20OS13662A	20.00	Open
				20-7-26 20OS13663A	20.00	Open
				20-7-28 11OS17738A	20.00	Open
				20-8-12 201051SM	8.00	Open
				20-8-12 AM	125.00	Open
				20-8-13 200989SM	20.00	Open
					<u>373.00</u>	
09/11/2020	528341	00001649	Home Depot/Comm. Credit	1022426	23.76	Open
				1033183	17.88	Open
				2022154	147.84	Open
				2023670	49.98	Open
				2024890	209.00	Open
				2024894	5.98	Open
				3021020	29.70	Open
				3023516	5.94	Open
				3023517	84.55	Open
				4024732	109.12	Open
				43230941less salesTax	58.67	Open
				5022021	51.94	Open
				5023160	41.94	Open
				5023206	99.94	Open
				6021866	277.79	Open
				7022998	75.42	Open
				7033021	4.97	Open
				7080366	24.85	Open
				8021568	24.29	Open
				9022660	85.06	Open
				2210663	(44.53)	Open
					<u>1,384.09</u>	
09/11/2020	528342	10004337	Idumesaro Law Firm, PLLC	20-7-2 190802389A	25.00	Open
				20-7-27 20OS13144A	20.00	Open
				20-7-27 20OS13706A	15.00	Open
				20-7-29 2004030M	140.00	Open
				20-7-29 2005620M	52.00	Open
				20-7-30 200590SM	220.00	Open
				20-7-29 AM	170.00	Open
				20-7-29 C098816	50.00	Open
				20-8-3 11B015110M	30.00	Open
				20-8-3 14OS29630B	150.00	Open
				20-8-3 18OS34179B	17.00	Open
				20-8-3 20OS09722A	20.00	Open
				20-8-3 2004890M	88.00	Open
				20-8-3 141367500M	17.00	Open

09/14/2020 03:04 PM
 User: JPETERS
 DB: Pontiac

CHECK REGISTER FOR CITY OF PONTIAC
 CHECK DATE FROM 09/05/2020 - 09/11/2020

Check Date	Check	Vendor	Vendor Name	Invoice Number	Amount	Status
				20-8-4 180S14533A	13.00	Open
				20-8-4 2002770M	20.00	Open
				20-8-5 2004840M	70.00	Open
				20-8-10 120S05056A	42.00	Open
				20-8-10 120S29396A	20.00	Open
				20-8-10 170S16314B	22.00	Open
				20-8-10 200S03249E	67.00	Open
				20-8-10 200S13144A	17.00	Open
				20-8-10 200S13706A	13.00	Open
				20-8-10 2002770M	33.00	Open
				20-8-10 2005250M	10.00	Open
				20-8-10 AM	120.00	Open
				20-8-11 190854SM	20.00	Open
					<u>1,481.00</u>	
09/11/2020	528343	REFUND DEP	Jacqueline Page	81847-235291	100.00	Open
09/11/2020	528344	10004256	Julius Smith Lawn Service	JuliusSmith003	1,750.00	Open
09/11/2020	528345	10003866	K and Q Law, PC	20-1-27 20-0094SM	75.00	Open
				20-2-4 20-00910M	75.00	Open
				20-2-4 20-00940M	75.00	Open
				20-2-15 20-0094SM	115.00	Open
				20-2-19 20-012550M	75.00	Open
				20-6-11 18-1491030D	20.00	Open
				20-6-15 200S03995A	20.00	Open
				20-7-17 18-1488210M	70.00	Open
				20-7-17 20-0065SM	70.00	Open
				20-7-20 20-03490T	45.00	Open
				20-7-22 AM	350.00	Open
				20-7-21 CO76150	70.00	Open
				20-7-22 CO76150	50.00	Open
				20-7-29 20-0121SM	450.00	Open
					<u>1,560.00</u>	
09/11/2020	528346	10003942	Law Office of D Ann Parker, PC	20-7-10 190528SM	100.00	Open
				20-7-30 AM	300.00	Open
				20-8-6 190528SM	50.00	Open
					<u>450.00</u>	
09/11/2020	528347	00012690	Law Offices of Paulette Michel, PLI	20-7-30 20-0396SM	250.00	Open
				20-7-30 200744SM	125.00	Open
				20-7-30 AM	100.00	Open
				20-8-18 AM MARTINEZ	100.00	Open
				20-8-18 AM G&W	175.00	Open
				20-8-24 AM	200.00	Open
				20-8-25 AM	200.00	Open
					<u>1,150.00</u>	
09/11/2020	528348	10003930	Leslie Tire Services, Inc.	3092425	638.00	Open
				2092575	915.00	Open
					<u>1,553.00</u>	
09/11/2020	528349	00010223	Lisa C Watkins Law Office	20-7-22 20-0766SM	100.00	Open
				20-7-23 20-0255SD	267.00	Open
					<u>367.00</u>	

09/14/2020 03:04 PM
 User: JPETERS
 DB: Pontiac

CHECK REGISTER FOR CITY OF PONTIAC
 CHECK DATE FROM 09/05/2020 - 09/11/2020

Check Date	Check	Vendor	Vendor Name	Invoice Number	Amount	Status
09/11/2020	528350	10000123	Marilyn D.Walker	20-7-20 RC-MARTINEZ	45.00	Open
				20-7-23 AM	150.00	Open
				20-7-26 110S15554	20.00	Open
				20-7-26 X3743718B	20.00	Open
				20-7-26 X3743718	20.00	Open
				20-8-3 200S06264	25.00	Open
				20-8-10 17X293715	20.00	Open
				20-8-11 20012958	25.00	Open
				20-8-13 AM	200.00	Open
					<u>525.00</u>	
09/11/2020	528351	00002024	Michigan Dept. of Transportation	8-4-20	78,883.08	Open
09/11/2020	528352	10004329	Nachawati Law, PLLC	20-8-3 AM	125.00	Open
09/11/2020	528353	10003945	Nancy Anne Plasterer	20-7-29 190S387069	125.00	Open
09/11/2020	528354	10001123	OfficeTeam-A Robert Half Company	56073219	731.23	Open
				56164367	797.70	Open
				56190247	744.52	Open
				56227447	777.76	Open
				56259816	691.34	Open
				56320432	717.93	Open
					<u>4,460.48</u>	
09/11/2020	528355	10004395	Pamar Enterprises, Inc	Pay Est#4	402,609.39	Open
09/11/2020	528356	00002316	Pitney Bowes Inc	1016230080	322.98	Open
09/11/2020	528357	00000688	Regina Press	6/18-7/8/20	30.00	Open
09/11/2020	528358	10004389	Rucker & Associates, P.C.	20-6-29 200S08601A	20.00	Open
				20-7-7 180S32093C	100.00	Open
				20-7-16 19-191066SM	150.00	Open
				20-7-27 200S08601A	100.00	Open
				20-8-4 200746SM	200.00	Open
					<u>570.00</u>	
09/11/2020	528359	00013067	Scott C. Kozak, Attorney at Law	20-7-4 120S06353	20.00	Open
				20-7-9 2004920M	25.00	Open
				20-7-24 190S11669	25.00	Open
				20-7-28 200S06371	25.00	Open
				20-8-24 AM	125.00	Open
					<u>220.00</u>	
09/11/2020	528360	00011704	Spencer Oil Company	012300-2021301	2,053.74	Open
09/11/2020	528361	00013050	Stacy A. Drouillard	20-7-2 180S19723B	25.00	Open
				20-7-16 190S22943A	20.00	Open
				20-7-27 2005520M	25.00	Open
				20-7-29 200S12174A	22.00	Open
				20-7-30 2000330M	25.00	Open
				20-7-31 2005450M	25.00	Open
				20-7-31 181488590M	25.00	Open
				20-8-5 190S35915B	25.00	Open
				20-8-10 120S00376B	17.00	Open
				20-8-10 200S12966B	42.00	Open
				20-8-10 2003300M	33.00	Open
				20-8-10 2005200M	30.00	Open
				20-8-10 AM	200.00	Open
				20-8-11 191112SM	167.00	Open

Check Date	Check	Vendor	Vendor Name	Invoice Number	Amount	Status
				20-8-12 130S1529B	12.00	Open
				20-8-12 130S24899A	17.00	Open
				20-8-12 200S08078A	8.00	Open
				20-8-12 200S120076B	17.00	Open
				20-8-12 2005400M	8.00	Open
				20-8-12 16143209OM`	17.00	Open
				20-8-12 110088757B	8.00	Open
				20-8-12 AM	100.00	Open
				20-8-17 AM	200.00	Open
					<u>1,068.00</u>	
09/11/2020	528362	REFUND DEP	Terese Teasley	R#81850-235890	50.00	Open
09/11/2020	528363	00000275	The Law and Mediation Center PLLC	20-8-13 AM	100.00	Open
09/11/2020	528364	10004376	Thomson Reuters Applications, Inc.	842920977	120.00	Open
09/11/2020	528365	00002748	Troy Fitzgerald Craft	6/18--7/8/20 7/11-7/25/20	34.00 <u>136.00</u>	Open Open
					170.00	
09/11/2020	528366	00010664	Truck & Trailer Specialties, Inc.	HSO007509	718.00	Open
09/11/2020	528367	00002776	United States Postal Service	Job#215582	3,532.55	Open
09/11/2020	528368	10004155	Volte, LLC	INV-0321	1,260.00	Open
09/11/2020	528369	10003813	Water Resource Commissioner	10-80898-00-0820 70-81022-00-0820 70-81023-00-0820 110-81011-00-0820 216-80906-08-0820 216-80907-01-0820 216-80908-00-0820 216-80909-03-0820 440-80918-08-0820 440-80919-02-0820 990-78699-00-0820	42.64 724.57 42.64 1,204.31 769.25 19.80 106.60 26.23 341.12 99.00 341.12	Open Open Open Open Open Open Open Open Open Open Open
					<u>3,717.28</u>	
				Total Paper Check:	<u>789,097.32</u>	
CONS TOTALS:						
Total of 61 Checks:					813,506.67	
Less 0 Void Checks:					<u>0.00</u>	
Total of 61 Disbursements:					813,506.67	
Bank COURT FIFTH THIRD-COURT OPERATING						
Check Type: Paper Check						
09/11/2020	8254	10004373	Barbara Jill Palulian	CER#7294 9/9/20	125.00	Open
09/11/2020	8255	10000593	Bromberg & Associates	15154	581.65	Open
09/11/2020	8256	00001244	Comcast Cablevision	8529101461030042	104.85	Open
09/11/2020	8257	10004223	Court Innovations Incorporated	INV15999	325.00	Open
09/11/2020	8258	10003909	Maria Fabiana Valy Gialdi	201082FY I 200394SM I	70.00 <u>70.00</u>	Open Open
					140.00	

09/14/2020 03:04 PM

User: JPETERS

DB: Pontiac

CHECK REGISTER FOR CITY OF PONTIAC
CHECK DATE FROM 09/05/2020 - 09/11/2020

Page: 9/9

Check Date	Check	Vendor	Vendor Name	Invoice Number	Amount	Status
09/11/2020	8259	10004108	Ricardo Caceres	200608FY I	87.55	Open
09/11/2020	8260	00012689	Smart Business Source, LLC	OE-27627-1	20,222.50	Open
Total Paper Check:					<u>21,586.55</u>	

COURT TOTALS:

Total of 7 Checks:	21,586.55
Less 0 Void Checks:	0.00
Total of 7 Disbursements:	<u>21,586.55</u>

REPORT TOTALS:

Total of 89 Checks:	853,679.22
Less 0 Void Checks:	0.00
Total of 89 Disbursements:	<u>853,679.22</u>

9-25-20

Check Register

09/29/2020 11:29 AM
 User: JPETERS
 DB: Pontiac

CHECK REGISTER FOR CITY OF PONTIAC
 CHECK DATE FROM 09/19/2020 - 09/25/2020

Check Date	Check	Vendor	Vendor Name	Invoice Number	Amount	Status
------------	-------	--------	-------------	----------------	--------	--------

Bank BOND FIFTH THIRD BOND ACCOUNT

Check Type: Paper Check

09/25/2020	13001	10002889	50th District Court	09A844462A F	45.00	Open
				190577ST F	200.00	Open
				190S25882A F	235.00	Open
				181491030D F	250.00	Open
				191491040T F	250.00	Open
				200887FY F	100.00	Open
				200888SM F	100.00	Open
				CO77328 10%	7.50	Open
				200890SM 10%	50.00	Open
				200890SM A	425.00	Open
				190S25932A F	45.00	Open
				X1950227A F	336.00	Open
				140S25449B F	45.00	Open
				190375SM 10%	25.00	Open
					<u>2,113.50</u>	
09/25/2020	13002	BOND	BRIAN BOLTON MUNCE	15172438LT E	680.00	Open
09/25/2020	13003	BOND	FATMIR CAPO	190S41096A R	90.00	Open
09/25/2020	13004	BOND	JENNIFER LEGGINS	CO77328 R	67.50	Open
09/25/2020	13005	BOND	JOSHUA HUGHES	190375SM R	225.00	Open
09/25/2020	13006	00002208	OAKLAND COUNTY CLERK	200671FY C	750.00	Open
				200184FY C	1,000.00	Open
				200823FY C	2,500.00	Open
					<u>4,250.00</u>	
09/25/2020	13007	BOND	ROBERT KHRUCCELL	190S08287A R	4.00	Open
09/25/2020	13008	BOND	ROLANDO LUIS ZAYAS	200890SM R	25.00	Open
				Total Paper Check:	<u>7,455.00</u>	

BOND TOTALS:

Total of 8 Checks:	7,455.00
Less 0 Void Checks:	0.00
Total of 8 Disbursements:	<u>7,455.00</u>

Bank CONS CONSOLIDATED

Check Type: EFT Transfer

09/22/2020	761(E)	10004301	PNC Bank	19419 Final payment	372.50	Open
				0021359	128.27	Open
				2218881687	312.25	Open
				2219004882	694.51	Open
				1971589 7 001 10730	289.50	Open
				2119103424	380.33	Open
				2219262267	783.70	Open
				50585	783.00	Open
				8192558141	1,511.98	Open

Check Date	Check	Vendor	Vendor Name	Invoice Number	Amount	Status
				A2D58EDF-0004	37.00	Open
				ID#26PMITED	125.00	Open
				TKR #703	159.00	Open
				6902603	1,398.92	Open
				ID-Trans# 1A-222148	254.40	Open
				61884	59.00	Open
				9193483CR	(110.28)	Open
					<u>7,179.08</u>	
09/25/2020	762 (E)	00000603	Oakland County Treasurer	2020-0915County	836,300.07	Open
09/25/2020	763 (E)	10003903	Pontiac Public Library	2020-0925 Library	54,333.86	Open
09/25/2020	764 (E)	00012890	Pontiac Schools	2020-0925 MESSA	24,858.83	Open
09/25/2020	765 (E)	00012890	Pontiac Schools	2020-0915Operating	911,381.52	Open
09/25/2020	766 (E)	00012890	Pontiac Schools	2020-0925Sinking	166,090.48	Open
				Total EFT Transfer:	<u>2,000,143.84</u>	
Check Type: Paper Check						
09/25/2020	528476	00001828	1231 Essential Spa dba	1231 Essentials Spa	75.00	Open
09/25/2020	528477	10004313	ADT Commercial LLC	136197048	49.95	Open
09/25/2020	528478	10001957	Ajax Materials Corporation	251290	347.20	Open
				251360	141.40	Open
				253234	289.80	Open
				253319	212.80	Open
					<u>991.20</u>	
09/25/2020	528479	10003879	Amazon.com LLC	1HJT-PX71-GHRL	28.54	Open
				16GQ-FKRP-D63C	113.27	Open
				19X1-QCPX-9491	149.90	Open
				CRLJ3R-RX3X-MYMW	(149.90)	Open
					<u>141.81</u>	
09/25/2020	528480	10004305	Ameena Razia Sheikh	20-6-14 190S25932A	20.00	Open
				20-7-10 200837SM	50.00	Open
				20-7-26 200992SM	20.00	Open
				20-8-19 200026SM	20.00	Open
					<u>110.00</u>	
09/25/2020	528481	10004322	Animal Xtractors	818	250.00	Open
				627	250.00	Open
				708	300.00	Open
				763	250.00	Open
					<u>1,050.00</u>	
09/25/2020	528482	00000050	AT & T	8310007501007-0920	1,294.90	Open
				8310007527298-0920	221.00	Open
					<u>1,515.90</u>	
09/25/2020	528483	00000050	AT & T	250472140-090820	84.61	Open
09/25/2020	528484	10002333	Auto Value - APC Store	313-666246	8.69	Open
				313-666417	10.98	Open
					<u>10.98</u>	

09/29/2020 11:29 AM
 User: JPETERS
 DB: Pontiac

CHECK REGISTER FOR CITY OF PONTIAC
 CHECK DATE FROM 09/19/2020 - 09/25/2020

Check Date	Check	Vendor	Vendor Name	Invoice Number	Amount	Status
					19.67	
09/25/2020	528485	00001074	Bedrock Express	107678	997.50	Open
09/25/2020	528486	10004207	Belem Morales Law Office	20-8-27 20-72981	25.00	Open
09/25/2020	528487	00001101	Blue Care Network Of SE Michigan	286401-0001-1020	3,401.51	Open
09/25/2020	528488	REFUND DEP	Brittney Jaynes	R81857-237912	100.00	Open
09/25/2020	528489	00010597	Charesa D. Johnson	20-6-23 19-1319SM	483.00	Open
				20-6-30 AM	200.00	Open
				20-8-14 18-OS-11787A	17.00	Open
				20-8-28 18-OS-11787A	68.00	Open
					<u>768.00</u>	
09/25/2020	528490	00001244	Comcast Cablevision	825-903542484-0920	334.18	Open
09/25/2020	528491	00001244	Comcast Cablevision	110-679435-0920	23.66	Open
				110-1037575-0920	174.91	Open
				825-946958-0920	324.45	Open
				6180-214665-0920	189.52	Open
				47450-862478-0920	125.44	Open
					<u>837.98</u>	
09/25/2020	528492	00013029	CompOne Administrators, Inc.	174620	8,080.00	Open
				174550	659.37	Open
					<u>8,739.37</u>	
09/25/2020	528493	00000206	Consumers Energy	216-97012165-0920	23.14	Open
				216-97012719-0920	9.64	Open
				350-96873280-0920	25.55	Open
				990-96288609-0920	83.97	Open
					<u>142.30</u>	
09/25/2020	528494	10004348	Cory Westmoreland	20-8-17 190S35317A	20.00	Open
				20-8-19 180S26817A	82.00	Open
				20-8-19 2005650M	110.00	Open
				20-8-19 171458460M	115.00	Open
				20-8-19 DH-Walker	97.00	Open
				20-8-26 2006430M	43.00	Open
					<u>467.00</u>	
09/25/2020	528495	10004156	Covenant Cemetery Services, Inc.	60345-R	2,500.00	Open
				51049-R	1,000.00	Open
					<u>3,500.00</u>	
09/25/2020	528496	10004243	Creative Schools Management, LLC	October 2020	26,000.00	Open
09/25/2020	528497	10000127	Delta Dental of Michigan	RIS0003014482	1,094.18	V Open
				RIS0003070601	1,094.18	V Open
					<u>2,188.36</u>	
09/25/2020	528498	10004332	Edith Blakney Law Firm, PLLC	20-6-23 1771216SD	375.00	Open
				20-7-23 200721SM	875.00	Open
				20-7-23 2073058SM	433.00	Open

Check Date	Check	Vendor	Vendor Name	Invoice Number	Amount	Status
				20-8-24 200S2446B	20.00	Open
				20-9-1 190334SM	100.00	Open
				20-9-3 201098SM	20.00	Open
				20-9-3 AM	100.00	Open
					<u>1,923.00</u>	
09/25/2020	528499	00000284	Elam Service Group	92120	1,200.00	Open
				092120	9,980.00	Open
				81720	5,850.00	Open
				62521	8,175.00	Open
					<u>25,205.00</u>	
09/25/2020	528500	10004306	Erika D. Morgan Law, PLLC	20-8-26 AM	83.00	Open
09/25/2020	528501	00010341	Fathom Studios, LLC	1393	2,500.00	Open
09/25/2020	528502	10004308	Forster Vine Rochester Auto Wash	219	40.00	Open
09/25/2020	528503	00000436	Gracey Law Firm, PLLC	20-7-20 130S2799A	33.00	Open
09/25/2020	528504	10000009	Great Lakes Auto Superstore LLC	October 2020	5,833.33	Open
09/25/2020	528505	10004085	Harlan Electric Company	1112274	665.70	Open
09/25/2020	528506	00001624	Hayden's Steam Cleaning Service Inc	01117	1,500.00	Open
09/25/2020	528507	REFUND TAX	Hernandez, Fransisca	R#214231	522.14	Open
09/25/2020	528508	10003261	Hillarie F. Boettger, PLLC	20-8-13 200989SM	20.00	Open
				20-8-20 AM	125.00	Open
					<u>145.00</u>	
09/25/2020	528509	00001649	Home Depot/Comm. Credit	0022611	220.96	Open
				0023754	218.25	Open
				0024764	33.22	Open
				1034322	19.12	Open
				4024328	27.88	Open
				4020878	459.29	Open
				6024034	254.68	Open
				6024043	73.10	Open
				7022940	643.52	Open
				8025046	49.19	Open
				8360109	57.36	Open
				9024894	51.94	Open
				9024914	29.70	Open
				9024958	35.64	Open
					<u>2,173.85</u>	
09/25/2020	528510	10004337	Idumesaro Law Firm, PLLC	20-6-16 20-0211SM	483.00	Open
				20-7-28 19-1653SM	488.00	Open
				20-8-25 200785SD	302.00	Open
				20-8-25 AM	163.00	Open
					<u>1,436.00</u>	
09/25/2020	528511	00013088	Innovative Software Services, Inc.	2378	23,432.46	Open
09/25/2020	528512	00012982	Insight Public Sector - PCM Sales	900706562	100.00	Open
				1100751835&100760952	1,131.59	Open
				1100755260	887.13	Open
				1100756167	616.05	Open
				1100757042	2,322.24	Open
				1100757834	527.81	Open
				1100758207	7,989.00	Open

09/29/2020 11:29 AM
 User: JPETERS
 DB: Pontiac

CHECK REGISTER FOR CITY OF PONTIAC
 CHECK DATE FROM 09/19/2020 - 09/25/2020

Check Date	Check	Vendor	Vendor Name	Invoice Number	Amount	Status
				1100765762	701.28	Open
				1100765763	27.00	Open
				1100766529	290.14	Open
				1100766941	1,529.98	Open
					<u>16,122.22</u>	
09/25/2020	528513	10003866	K and Q Law, PC	20-8-18 AM	333.00	Open
				20-8-23 16OS16410B	28.00	Open
				20-8-23 20-0277OM	37.00	Open
				20-8-23 20-0557OT	50.00	Open
				20-8-24 12OS14236A	28.00	Open
				20-8-24 15OS25689	40.00	Open
				20-8-24 200873SM	55.00	Open
				20-8-24 AM	100.00	Open
				20-8-25 AM	150.00	Open
				20-8-31 13OS10757A	20.00	Open
				20-8-31 20OS0394B	20.00	Open
				20-9-4 200291OM	58.00	Open
				20-9-1 20OS15634A	75.00	Open
					<u>994.00</u>	
09/25/2020	528514	10004388	Law Office of Christophen R Shemke	20-8-18 20OS07742C	325.00	Open
				20-8-31 16OS37328B	25.00	Open
				20-8-31 19OS24131A	183.00	Open
				20-8-31 20OS08337A	35.00	Open
				20-9-3 201167SM	8.00	Open
				20-9-3 1669433SD	7.00	Open
					<u>583.00</u>	
09/25/2020	528515	10003741	Law Offices of Nadine R.Hatten, PLLC	20-6-16 18-74062SM	8.00	Open
				20-6-16 18-74061SM	75.00	Open
				20-6-19 20-0347SM	50.00	Open
				20-6-23 AM	200.00	Open
				20-8-24 201087SM	100.00	Open
				20-8-26 191362SM	5.00	Open
				20-8-27 AM	200.00	Open
					<u>638.00</u>	
09/25/2020	528516	00012690	Law Offices of Paulette Michel, PLLC	2194 July 2020	3,750.00	Open
				2264 AUG. 2020	3,750.00	Open
					<u>7,500.00</u>	
09/25/2020	528517	00010223	Lisa C Watkins Law Office	20-6-16 20-0597SM	115.00	Open
				20-8-13 17-146375OM	20.00	Open
				20-8-3 20-OS04799A	33.00	Open
				20-8-8 15-OS01794A	50.00	Open
				20-8-10 20-OS13811A	33.00	Open
				20-8-12 AM	200.00	Open
				20-8-15 16-OS30202A	33.00	Open
				20-8-18 AM	330.00	Open
				20-8-19 AM	130.00	Open
				20-8-25 20-0098SM	375.00	Open
				20-9-1 20-OS05671B	50.00	Open
					<u>1,369.00</u>	

Check Date	Check	Vendor	Vendor Name	Invoice Number	Amount	Status
09/25/2020	528518	00002000	Micah 6 Community	GrahamCassano 6-19-	2,200.00	Open
09/25/2020	528519	10004048	Nation Home Improvement	090120	2,500.00	Open
09/25/2020	528520	REFUND DEP	New Creation Homes, Inc	R#235945	3,530.50	Open
09/25/2020	528521	00002221	Oakland County Executive Office	2020-0925Brownsfield	214,095.89	Open
09/25/2020	528522	10000078	Occupational HealthCenters of MI	P713377527	772.00	Open
09/25/2020	528523	00011236	PreCise MRM LLC	200-1027256	65.28	Open
09/25/2020	528524	10000814	Professional Instant Printing, Inc.	77835	294.00	Open
				77837	147.00	Open
				77852	505.00	Open
				77864	88.50	Open
					<u>1,034.50</u>	
09/25/2020	528525	10003237	Pura Vida Jamaican and	Invoice 001	300.00	Open
09/25/2020	528526	00013067	Scott C. Kozak, Attorney at Law	20-7-17 200S12238	25.00	Open
				20-8-4 190S36976	20.00	Open
				20-8-11 2005810M	50.00	Open
				20-7-21 200599SM	250.00	Open
					<u>345.00</u>	
09/25/2020	528527	10003760	Scott's Lock & Key Shop	1339	29.25	Open
09/25/2020	528528	REFUND DEP	Shantanique McDonald	R81860-238090	100.00	Open
09/25/2020	528529	00013050	Stacy A. Drouillard	20-8-25 191258SD	343.00	Open
				20-8-31 2001880M	50.00	Open
					<u>393.00</u>	
09/25/2020	528530	00012256	Staples Business Advantage	8059352924-454076149	170.16	Open
				8059352924-454076152	274.59	Open
				8059352924-454076154	25.49	Open
				8059352924-454076154	7.64	Open
					<u>477.88</u>	
09/25/2020	528531	00002630	State of Michigan	2020-0915SET	456.00	Open
09/25/2020	528532	10004140	Techniserive Inc.	39843	540.75	Open
09/25/2020	528533	00000275	The Law and Mediation Center PLLC	20-8-11 AM	250.00	Open
				20-8-13 200DS01624A	37.00	Open
				20-8-13 190395SD	53.00	Open
				20-8-13 200985SM	45.00	Open
				20-8-17 190823SM	25.00	Open
				20-8-28 2075613	70.00	Open
					<u>480.00</u>	
09/25/2020	528534	00002783	University Lawn Equipment, Inc.	3126	719.92	Open
09/25/2020	528535	00000851	Wade-Trim/Associates	2018984	140,975.00	Open
09/25/2020	528536	00002832	Waterford A Charter Township	September 15, 2020	1,978,236.42	Open
				Total Paper Check:	<u>2,491,489.43</u>	

CONS TOTALS:

Total of 67 Checks:	4,491,633.27
Less 1 Void Checks:	<u>2,188.36</u>
Total of 66 Disbursements:	<u>4,489,444.91</u>

Check Date	Check	Vendor	Vendor Name	Invoice Number	Amount	Status
------------	-------	--------	-------------	----------------	--------	--------

Bank COURT FIFTH THIRD-COURT OPERATING

Check Type: Paper Check

09/22/2020	8268	10002889	50th District Court	9/21/20 DEPOSIT	1.16	Open
09/25/2020	8269	00000050	AT & T	248857950109	35.60	Open
09/25/2020	8270	10004373	Barbara Jill Palulian	CER#7294 9/3/20	250.00	Open
09/25/2020	8271	00001353	Detroit Elevator Co.	189346	852.00	Open
09/25/2020	8272	10004110	Eric Adam Nissani	200S15581A I	70.00	Open
09/25/2020	8273	00012982	Insight Public Sector - PCM Sales	1100764248	4,078.68	Open
09/25/2020	8274	10003909	Maria Fabiana Valy Gialdi	200S13971A I	70.00	Open
09/25/2020	8275	00002244	OFFICE DEPOT	123549434001	90.53	Open
				123547559001	14.99	Open
				123549435001	299.80	Open
					<u>405.32</u>	
09/25/2020	8276	00002483	ROSE PEST SOLUTIONS	30889048	50.00	Open
09/25/2020	8277	00012362	STAPLES CREDIT PLAN	2628909631	621.74	Open
				2639604091	462.43	Open
				2640569361	32.91	Open
					<u>1,117.08</u>	
09/25/2020	8278	00002621	State Bar Of Michigan	379721	350.00	Open
				379925	315.00	Open
				379704	315.00	Open
				378482	315.00	Open
				380358	315.00	Open
					<u>1,610.00</u>	
09/25/2020	8279	10004418	Susan M Moiseev	MOISEEV 9/21/20	637.95	Open
				Total Paper Check:	<u>9,177.79</u>	

COURT TOTALS:

Total of 12 Checks:	9,177.79
Less 0 Void Checks:	0.00
Total of 12 Disbursements:	<u>9,177.79</u>

Bank PNCMM PNC MONEY MARKET

Check Type: EFT Transfer

09/25/2020	154(E)	00013053	City of Pontiac	2020-0915City	1,091,121.48	Open
				Total EFT Transfer:	<u>1,091,121.48</u>	

PNCMM TOTALS:

Total of 1 Checks:	1,091,121.48
Less 0 Void Checks:	0.00
Total of 1 Disbursements:	<u>1,091,121.48</u>

09/29/2020 11:29 AM

User: JPETERS

DB: Pontiac

CHECK REGISTER FOR CITY OF PONTIAC
CHECK DATE FROM 09/19/2020 - 09/25/2020

Page: 8/8

Check Date	Check	Vendor	Vendor Name	Invoice Number	Amount	Status
------------	-------	--------	-------------	----------------	--------	--------

REPORT TOTALS:

Total of 88 Checks:

5,599,387.54

Less 1 Void Checks:

2,188.36

Total of 87 Disbursements:

5,597,199.18