

PONTIAC CITY COUNCIL

Kermit Williams, District 7
President
Randy Carter, District 4
President Pro Tem



Patrice Waterman, District 1
Megan Shramski, District 2
Mary Pietila, District 3
Gloria Miller, District 5
Dr. Doris Taylor Burks, District 6

It is this Council's mission "To serve the citizens of Pontiac by committing to help provide an enhanced quality of life for its residents, fostering the vision of a family-friendly community that is a great place to live, work and play."

47450 Woodward Pontiac, MI 48342 Phone: (248) 758-3200
Website: <http://pontiaccityclerk.com/city-council-meetings>

Garland S. Doyle, M.P.A.
Interim City Clerk

STUDY SESSION
246th Session of the 10th Council
July 27, 2021 at 6:00 P.M.
Bowens Center 52 Bagley Pontiac, MI 48341

Call to order

Roll Call

Authorization to Excuse Councilmembers

Approval of the Agenda

Approval of the Minutes

1. July 20, 2021

Public Comment

Agenda Items

Topic: Marihuana

Special Presentation (Special Presentations are limited to 10 minutes.)

2. Marihuana in Pontiac
Presentation Presenters: Garland Doyle, Interim City Clerk and Jonathan Starks, Assistant City Clerk/Regulatory Analyst

Resolution

City Attorney

3. Resolution to adopt rules and regulations for the Medical Marihuana Commission

Communication from the City Clerk

4. Memorandum on City Council adoption of the rules prior to the Medical Marihuana Commission approving them would be a violation of Ordinance 2357(B) City of Pontiac Medical Marihuana Facilities Ordinance approved by Pontiac voters

Topic: American Rescue Plan

Special Presentation (Special Presentations are limited to 10 minutes.)

5. American Rescue Plan (ARP): Town Hall to Engage Citizen Input
Presentation Presenters: Mayor Waterman, Darin Carrington, Finance Director, and Alexandra Borngesser, Contract Compliance/Grant Writer

Topic: Department of Public Works (DPW)

Resolutions

6. Resolution to approve a one-year extension for Great Lakes Contracting Solutions, LLC for Roadway Maintenance Program
7. Resolution to approve a one-year extension for Great Lakes Power and Light for Street Light Maintenance
8. Resolution to approve contract between the City and Koala-T Construction, Inc. for the Community Development Block Grant (CDBG) Sidewalk Improvement Project in the amount of \$481,616.00
9. Resolution to approve contract between the City and Mark Anthony Contracting, Inc. for the Vanguard Drive Reconstruction Project in the amount of \$617,118.69

Topic: Ewalt

Resolutions

10. Resolution to uncommit \$3.2 million in the general fund's committed fund balance, initially committed for the purchase of the Youth Recreation and Enrichment at 825 Golf Road and to transfer \$3.2 million to the Capital Improvement's committed fund balance towards leasehold improvements at the Ewalt Community Center.
11. Resolution to approve a Budget Amendment for Fiscal Year 2021-2022 to Allocate a Total of \$3.2 Million, from the Capital Improvement Fund's Committed Fund to the Capital Improvement Fund Account 445-756-971.00 to be Used for Restoration of the Ewalt Community Center as a Youth Community Center.

Topic: Budget Amendments

Resolutions

12. Resolution to approve Budget Amendment for Fiscal Year 2021-2022 to allocate a Total of \$4,220,000 for Construction and Engineering Services.
13. Resolution to approve Budget Amendment for Major Streets, Local Streets and General Fund. **(The resolution was not provide for this budget amendment.)**
14. Resolution to approve a Budget Amendment for Fiscal Year 2021-2022 to allocate an Additional \$352,635 to the Overtime Budget for Public Safety Services.

Topic: Retirees

Ordinance

15. Ordinance to amend the City of Pontiac General Employees' Retirement System to Clarify Asset Distribution upon Termination.

Resolutions

16. Resolution to request for Actuarial Study an Extension of Supplemental Pension Payment for GERS Retirees
17. Resolution to approve the First Amendment to the VEBA Declaratory Trust Agreement.
18. Resolution to approve the Amendment to the Retiree Group Health Insurance Plan.
19. Resolution to approve Actuarial Study for Permanent Increase of Retiree Monthly Pension Benefits.

Topic: Mayor's Office

Resolution

20. Resolution to approve Mayor's Appointment of Mark Holland as Deputy Mayor

Communication from the Mayor

21. Proclamation Declaring WWI Greatest Generation Day

Adjournment

#1

MINUTES

July 20, 2021 Formal

**Official Proceedings
Pontiac City Council
245th Session of the Tenth Council**

Call to order

A Formal Meeting of the City Council of Pontiac, Michigan was called to order at the Bowens Senior Center, 52 Bagley Pontiac, MI 48342 on Tuesday, July 20, 2021 at 6:00 p.m. by Council President Kermit Williams.

Invocation – Dr. Doris Taylor-Burks

Pledge of Allegiance

Roll Call

Members Present – Carter, Miller, Pietila, Shramski, Taylor-Burks, Waterman and Williams
Mayor Waterman was present.
Clerk announced a quorum.

Amendments to and Approval of the Agenda

21-209 **Motion to add-on Boys & Girls Club concept presentation after the approval of the minutes.** Moved by Councilperson Waterman and second by Councilperson Taylor-Burks.

Ayes: Miller, Pietila, Shramski, Taylor-Burks, Waterman, Williams and Carter

No: None

Motion Carried.

21-210 **Motion to approve the Agenda as amended.** Move by Councilperson Pietila and second by Councilperson Taylor-Burks.

Ayes: Pietila, Shramski, Taylor-Burks, Waterman, Williams, Carter and Miller

No: None

Motion Carried

Approval of the Minutes

21-211 **Motion to approve meeting minutes for July 13, 2021.** Moved by Councilperson Pietila and second by Councilperson Taylor-Burks.

Ayes: Shramski, Taylor-Burks, Waterman, Williams, Carter, Miller and Pietila

No: None

Motion Carried

Concept Presentation- Boys and Girls Club

Suspend the Rules

21-212 **Suspend the rules to set up Ad-hoc Subcommittee for Ewald Recreation.** Moved by Councilperson Pietila and second by Councilperson Taylor-Burks.

Ayes: Taylor-Burks, Waterman, Williams, Carter, Miller, Pietila and Shramski

No: None

Motion Carried

21-213 **Motion to establish City Council Subcommittee to Ewald Recreation and nominate Councilperson Miller, Pietila and Shramski to be on the committee. The committee will make a recommendation on an Ewald Recreation Center Project then their recommendation will be referred to the Finance Subcommittee.** Moved by Councilperson Waterman and second by Councilperson Taylor-Burks.

Ayes: Waterman, Williams, Carter, Miller, Pietila, Shramski and Taylor-Burks

No: None

Motion Carried

Point of Privilege – State Senator Rosemary Bayer

Subcommittee Reports

Received Community Development Report – June 29, 2021

Received Public Safety Report – July 14, 2021

Councilwoman Pietila wanted it noted in the minutes that the Clerk did not include the Fire Department report with the public safety report. The entire public safety report is attached as exhibit A.

Discussions

Appointment of the Deputy Mayor

Status Update on the cleaning of the Council Chambers ventilation ducts

Status Update on the appointment of the Medical Marijuana Commission

Communication from the City Clerk

Council needs to determine if it wants to amend its rules to move special presentations from the Formal Meeting to the Study Session

Suspend the Rules

21-214 **Suspend the rules.** Moved by Councilperson Pietila and second by Councilperson Taylor-Burks.

Ayes: Williams, Carter, Miller, Pietila, Shramski, Taylor-Burks and Waterman

No: None

Motion Carried

21-215 **Motion to move Special presentations from Formal Meeting to Study Session with a limit of three (3) presentation and a time limit of 10 minutes.** Moved by Councilperson Pietila and second by Councilperson Shramski.

Ayes: Carter, Miller, Pietila, Shramski, Taylor-Burks, Waterman and Williams

No: None

Motion Carried

Adjournment

President Kermit Williams adjourned the meeting at 7:42 p.m.

JONATHAN STARKS
ASSISTANT CITY CLERK

Public Safety Subcommittee Minutes of July 14, 2021.

Meeting was called to order at 9:15 a.m. Present was Councilwoman Sharamski, Star EMS Training Manager Jayson Browe, Fire John Phebus, SSgt. S. Law and Chairperson Mary Pietila, absent was Council Prottem, Randy Carter.

We opened our meeting with a discussion on overtime within the OCDS Budget, beings it was such a topic at Tuesday night's meeting; it seems there was some misunderstanding. Overtime is not due to special events, when there are events that are not hosted by the City; the overtime is incorporated to that events budget. The Greater Pontiac Community Coalition, no longer hosts the Dream Cruise, the Mayor has taken that over several years ago, therefore they {GPCC} does not contribute the additional funds as was mentioned at Tuesdays meeting, however there is no Overtime included for that event, as a unit that normally does not work on the weekends is called in on that Saturday and given n additional day off during the week. The overtime budget is occurred as was stated on Tuesday during the meeting by investigations of major crimes and Court appearances, as long as there is criminal activity in this City there will be Overtime costs whether we are OCSD or Pontiac Police, the question is are we ready to start with new fresh out of the academy unexperienced Police officers, or officers who have been terminated for just cause with other departments?

Fire report is included, average response time is 5.16 minutes, the state requirement is 6.00 minutes. There were no injuries to civilians or personnel for the month of June.

Star EMS reported that there were No Car seat checks due to COVID
Still could more staff but we did have 4 hired this month, but all part timers.

Meeting was adjourned at 10:30 and will meet next month on August 11, 2021 @ 9:00 a.m. in the Lions Den.

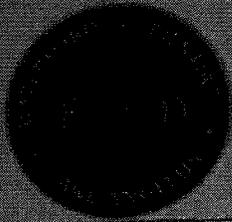

WATERFORD REGIONAL FIRE DEPARTMENT

2495 Crescent Lake Road • Waterford, MI 48329
Phone: 248.673.0405 • Fax: 248.674.4095
www.waterfordmi.gov

Matthew J. Covey, Fire Chief • Carl J. Wallace, Deputy Fire Chief • John R. Phebus, Fire Marshal

MONTHLY FIRE DEPARTMENT REPORT For the City of Pontiac June 2021

Total Pontiac Fire Station calls - month: **487** Average Response Time **5.16** min. per call
Total calls for Pontiac Stations - YTD: **2,298**
City Calls: Fires 17 EMS: **291** False Alarms: 47 Other: 132
Pontiac YTD: Fires 115 5% EMS: 1,382 60%
False Alarms 181 7% Other 620 28 %

| Month Count | Response Times | YTD |
|------------------|----------------|-----|
| FS-6: Fires - 02 | 5:06 | 017 |
| EMS -55 | 5:34 | 267 |
| FS-7: Fires -10 | 6:11 | 055 |
| EMS -129 | 5:07 | 570 |
| FS-8: Fires - 03 | 5:33 | 021 |
| EMS -51 | 5:29 | 291 |
| FS-9: Fires -02 | 4:52 | 020 |
| EMS -53 | 4:29 | 239 |

NOTE: Totals per Station could reflect response out of the city limits.

Fire Injuries to personnel: Zero Fire Injuries to civilian: Zero

Notable Event:

- EMS Training for June was Pediatric Trauma.
- Fire Training for June was Leadership session 3 and ongoing general firefighting skills training.
- WRFD hosted a 3-day OAKWAY Peer support training (in person).
- TNT Trench Rescue Tech. class Howell operator's union training site- 1 member.
- Crews are pleased to once again attended public events in which we attend in both the City and Township throughout the month.

Oakland County Sheriff's Office
Pontiac Substation
2021

7/26/2021 9:27

| Road Patrol/DB | January | February | March | April | May | June | July | August | Sept | October | November | December | Totals |
|-------------------------------|----------------|-----------------|--------------|--------------|------------|-------------|-------------|---------------|-------------|----------------|-----------------|-----------------|---------------|
| Road Patrol Arrests: | 293 | 293 | 355 | 308 | 306 | 257 | | | | | | | 1,812 |
| Traffic Citations: | 219 | 290 | 302 | 352 | 324 | 474 | | | | | | | 1,961 |
| Detective Bureau Warrants: | 111 | 115 | 143 | 132 | 120 | 121 | | | | | | | 742 |
| Cases Assigned to Detectives: | 404 | 325 | 403 | 396 | 432 | 403 | | | | | | | 2,363 |
| Appearance Citations: | 8 | 7 | 13 | 10 | 6 | 5 | | | | | | | 49 |
| DNA Swabs | 1 | 0 | 0 | 0 | 0 | 0 | | | | | | | 1 |

Domesic Violence Arrests

| | | | | | | | | | | | | | |
|---------------------|----|----|----|----|----|----|--|--|--|--|--|--|-----|
| State Law Warrants: | 38 | 34 | 44 | 47 | 41 | 40 | | | | | | | 244 |
|---------------------|----|----|----|----|----|----|--|--|--|--|--|--|-----|

Directed Patrol Unit

| | | | | | | | | | | | | | |
|---------------------------------|-----------|-----------|-----------|----------|----------|----------|--|--|--|--|--|--|-----------|
| Felony Arrests: | 50 | 48 | 43 | 35 | 42 | 37 | | | | | | | 255 |
| Misdemeanor Arrests in Custody: | 9 | 14 | 7 | 8 | 6 | 7 | | | | | | | 51 |
| Appearance Citations: | 8 | 13 | 5 | 2 | 1 | 3 | | | | | | | 32 |
| Traffic Citations: | 0 | 0 | 0 | 0 | 0 | 0 | | | | | | | 0 |
| Controlled Buys: | 0 | 0 | 0 | 0 | 0 | 0 | | | | | | | 0 |
| Drugs Seized-Value: | \$ 8,000 | \$ 17,010 | \$ 14,115 | \$ 9,570 | \$ 2,985 | \$3,505 | | | | | | | \$ 55,185 |
| Money Seized: | \$ 67,990 | \$ 687 | \$ 2,445 | \$ 7,687 | \$ 5,415 | \$ 1,946 | | | | | | | \$ 86,170 |
| Handguns Seized: | 8 | 13 | 14 | 7 | 12 | 8 | | | | | | | 62 |
| Long Guns Seized: | 0 | 0 | 0 | 0 | 0 | 0 | | | | | | | 0 |
| Search Warrants Executed: | 0 | 0 | 0 | 0 | 0 | 0 | | | | | | | 0 |

Violent Crimes Statistics

| | | | | | | | | | | | | | |
|----------------------------------|---|---|---|---|---|---|--|--|--|--|--|--|----|
| Armed Robberies | 3 | 7 | 2 | 3 | 4 | 4 | | | | | | | 23 |
| Homicides: | 1 | 1 | 0 | 1 | 0 | 0 | | | | | | | 3 |
| Discharged Firearm (Injuries): | 6 | 0 | 3 | 3 | 8 | 8 | | | | | | | 28 |
| Discharge Firearm (No Injuries): | 0 | 1 | 3 | 4 | 2 | 3 | | | | | | | 13 |
| Weapons Involved/Brandished: | 2 | 3 | 1 | 0 | 4 | 5 | | | | | | | 15 |

| DISPATCH | 21-Jan | 21-Feb | 21-Mar | 21-Apr | 21-May | Jun-21 |
|----------------------------|--------|--------|--------|--------|--------|--------|
| Abdominal Pain | 29 | 24 | 31 | 18 | 34 | 21 |
| airmedical transport | | | 1 | | 1 | |
| ALLergies | 3 | 4 | 4 | 7 | 2 | 6 |
| ALTERED MENTAL STATUS | 7 | 4 | 10 | 6 | 6 | 13 |
| Animal bites | 1 | | 3 | 2 | 1 | |
| Assault | 27 | 26 | 12 | 20 | 27 | 23 |
| Invalid assist | 2 | 4 | 7 | 4 | 7 | 5 |
| Pedestrian struck by Auto | | | | | | |
| Back Pain | 102 | 12 | 17 | 20 | 14 | 14 |
| Breathing Problems | | 77 | 93 | 133 | 94 | 90 |
| Boating Accident | | | | | | |
| Burns | | | | 2 | 1 | 2 |
| Cardiac Arrest | 15 | 17 | 23 | 17 | 22 | 27 |
| Chest pain | 71 | 50 | 57 | 80 | 63 | 80 |
| Choking | 2 | 6 | 2 | 4 | 3 | 6 |
| CO poisoning | 1 | | | 1 | | 1 |
| Seizures | 44 | 40 | 43 | 39 | 49 | 46 |
| Diabetic Issues | 25 | 18 | 26 | 21 | 30 | 21 |
| Drowning | | | | | | 1 |
| Unspecified EMS SERVICE | | | | | 2 | 19 |
| Electrocution | | | | 1 | 1 | |
| Eye issues | | 2 | | | 2 | 2 |
| Fainting | | | | | | |
| Fall Victim | 57 | 54 | 45 | 58 | 60 | 51 |
| Fever | | | | | | |
| Fire | | | | | | |
| Headache | 1 | 5 | 2 | 5 | 9 | 2 |
| Heart Problems | 15 | 13 | 4 | 4 | 8 | 12 |
| Heat/Cold Exposures | 3 | 2 | 2 | 1 | | |
| Hemorrhage from Laceration | 16 | 13 | 14 | 13 | 13 | 19 |
| Industrial Accident | | 1 | | | | |
| Medical alarms | 5 | 9 | 1 | 5 | 8 | 16 |
| MCI | | | | | | |
| Ingested Poison | | | | | | |
| Non Emergent requests | | | 9 | | 7 | |
| Overdose | 29 | 34 | 37 | 33 | 49 | 50 |
| Pregnancy/Childbirth | 9 | 4 | 2 | 6 | 7 | 3 |
| Psychiatric Problems | 37 | 33 | 36 | 35 | 31 | 36 |
| Respiratory Arrest | | | | | | |
| "Sick" Person | 165 | 117 | 198 | 212 | 193 | 208 |
| Standby | | | | | 1 | |
| stab/Gunshot Wound | 5 | 5 | 5 | 2 | 12 | 4 |
| Stroke/CVA | 20 | 16 | 16 | 13 | 18 | 16 |
| Traffic Accidents | 21 | 33 | 38 | 35 | 39 | 43 |
| Palliative care | 29 | 28 | 28 | 31 | 28 | 23 |
| Traumatic Injury | 11 | 19+ | 11 | 16 | 17 | 16 |
| Unconscious/unknown cause | 29 | 34 | 28 | 22 | 48 | 46 |
| UNKNOWN | 9 | 12 | 4 | | 1 | |
| "Person DOWN" | 16 | 5 | 22 | 13 | 20 | 19 |
| Sexual Assault | | | | | | |
| Well Person Ck | 2 | 2 | 2 | 1 | 2 | 3 |
| | | | | | | |
| total | 808 | 704 | 833 | 880 | 930 | 944 |

| | 21-Jan | 21-Feb | 21-Mar |
|----------------|--------|--------|--------|
| 48340 | 5.1 | 4.9 | 5 |
| 48341 | 4.8 | 4.8 | 4.9 |
| 48342 | 4.9 | 4.9 | 4.9 |
| | | | |
| | | | |
| Monthly | 4.9 | 4.86 | 4.9 |
| | | | |
| | June | | |
| 48340 | 5.6 | | |
| 48341 | 5.4 | | |
| 48342 | 5.3 | | |
| | | | |
| | | | |
| Monthly | 5.43 | | |

21-Apr May

| | |
|-----|-----|
| 5.2 | 5.8 |
| 4.8 | 5.3 |
| 5 | 5 |

5

#2

**SPECIAL
PRESENTATION**



MARIHUANA IN PONTIAC

City Council Presentation July 27, 2021

Garland Doyle, M.P.A., CNP
Interim City Clerk

Jonathan Starks
Assistant City Clerk/Regulatory Analyst
Marihuana Regulations Division

Website: <http://pontiaccityclerk.com/medical-marihuana>

 Pontiac City Clerk

 PontiacClerk

 Pontiac City Clerk

 Pontiac City Clerk

A Fair and Transparent Process

Agenda

- 1) Overview of Ordinances
- 2) Application Process

- 3) Review Team
- 4) Provisioning Center Scoring
- 5) Application Review Process
- 6) Overlay Districts and Appeal Process
- 7) Conditional Approvals
- 8) Citizen Monitoring Taskforce
- 9) Caregiver Ordinance
- 10) Recreational Marihuana Ordinance

1) Overview of Ordinances

City of Pontiac Medical Marihuana Facilities Ordinance Ordinance 2357(B)

- Approved by citizens of Pontiac in August 2018
- Granted the City Clerk the authority to oversee the Medical Marihuana Process
- License up to 20 Provisioning Centers using a 130 point scale
- License unlimited Growers, Processors, Safety Compliance and Secure Transporters

Zoning Ordinance for Medical Marihuana Ordinance 2363

- Approved by the Pontiac City Council in April 2019
- Stated where growers, processors, safety compliance, secure transporters and provisioning centers could locate
- Created three Medical Marihuana Overlay Districts
 - Cesar Chavez
 - Downtown
 - Walton Blvd

2) Application Process

When were applications accepted for provisioning centers?

Jan. 6 – 27, 2020 a one-time 21 Day Application Period.

How are applications ranked?

By district, provisioning center applicants applied by district.

When are applications accepted for growers, processors, safety compliance and secure transporters?

Monday-Friday 8:30a.m. – 4:30p.m. We began accepting applications in April 2019.

When did the review process begin?

The application review process began in June 2020 after the professional experts contracts were signed.

Why has it taken several months to review applications?

The Office of the City Clerk is responsible for administering elections. In 2020, we faced a record turnout election and had to devote all of the Clerk's staff and resources from July-November 2020 to the election.

3) Review Team

Medical Marihuana Division Org Chart

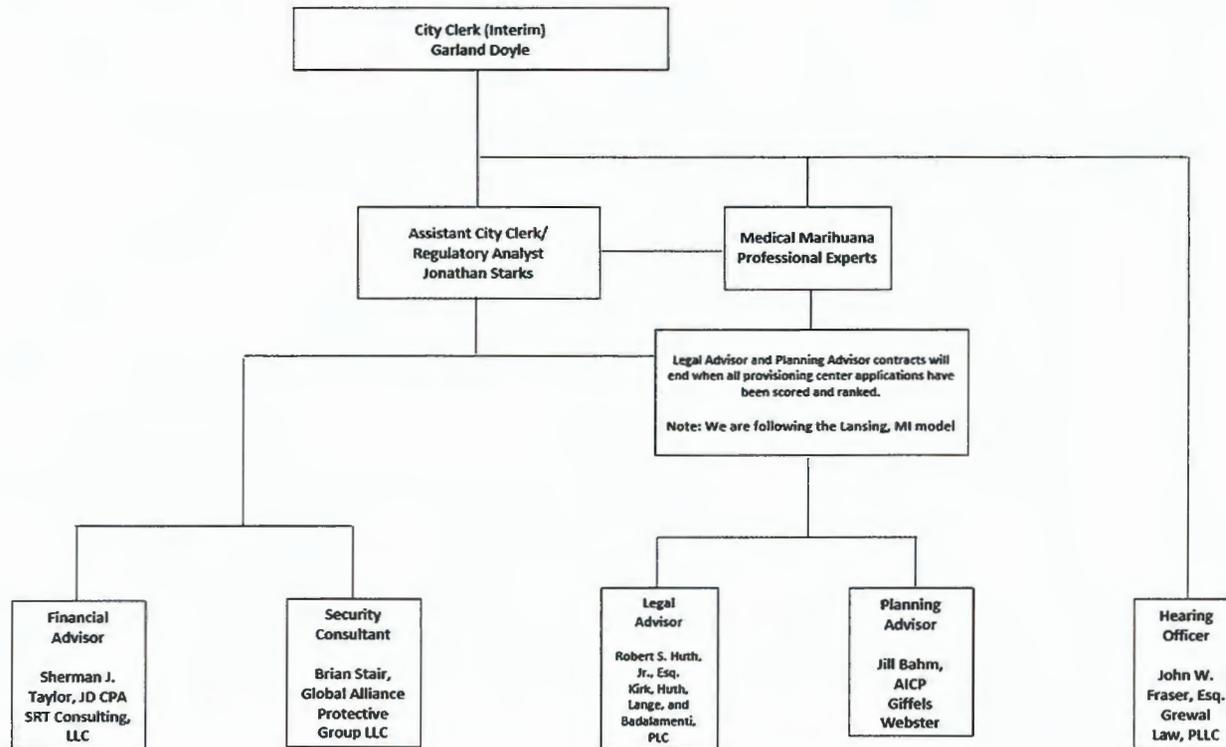

The following City Departments and Divisions are a part of the review team.

•Department of Public Works (DPW), Planning, Building & Safety and the Waterford Regional Fire Department

A Fair and Transparent Process

4) Provisioning Center Scoring

City of Pontiac
Office of the City Clerk
Medical Marihuana Provisioning Center Scoring Form

| Application Category | Applicant Points | Maximum Points |
|---|------------------|----------------|
| Content and Sufficiency of Information | | 50 |
| Background Information | | 5 |
| Marihuana Regulations | | (1.5) |
| Business Entity | | (2) |
| Security | | (1.5) |
| Financial Background | | 10 |
| Economic Benefits | | 10 |
| Community Development | | 10 |
| Facility (Planning and Sanitation) | | 10 |
| Planning | | (8) |
| Sanitation | | (2) |
| Patient Education | | 5 |
| Staff Training and Education | | (2.5) |
| Patient and Community Programs | | (2.5) |
| Land Use | | 20 |
| Resident Safety | | 10 |
| Neighborhood Land Use | | 10 |
| Community Impact | | 10 |
| Managerial Resources | | 10 |
| Financial Resources | | 10 |
| Job Creation | | 10 |
| Philanthropic and Community Improvement | | 10 |
| Physical Improvements | | 10 |
| Applicant Total Score | | 130 |

Applicant Ranking: ____ of ____ Total Applicants

A Fair and Transparent Process

5) Application Review Process

- Review Phase 1** → Content Review
 - Clerk staff will review application to make sure all information and exhibits have been submitted.
- Review Phase 2** → Default Review
 - Staff from each department/division checks the applicant name and stakeholders to ensure they are not in default with the city.
- Review Phase 3** → Evaluation and/or Scoring Review
 - Review team members evaluate and or score their respective sections of the application.
- Review Phase 4** → Compliance Review
 - The legal and planning advisors ensures that satisfactory and unsatisfactory standards have been consistently applied by reviewers for Grower, Processor, Secure Transporter, and Safety Compliance.
 - The legal and planning advisors ensures that Satisfactory, Somewhat Deficient, and Very Deficient
- Review Phase 5** → Provisioning Centers Applications Ranked by District
 - Conditional Approval, Notice of Deficiencies or Application Denial for Grower, Processor, Safety Compliance and Secure Transporter
 - If applicant receives conditional approval, they advance to Phase 6
 - If application is denied, applicant can file an appeal. (See Appeal Process)
- Review Phase 6**
 - Site Plan Approval and/if necessary Special Exemption Approval Appeal.
- Review Phase 7**
 - Certificate of Compliance/Occupancy from Building and Fire.
- Review Phase 8**
 - Clerk issues a permit provided you have been issued your pre-qualification from the State of Michigan.

Cesar Chavez Overlay District Provisioning Centers Applications Rankings

- 1) Rize Cannabis
 - 2) West Fort Holdings LLC
 - 3) Greenhouse Farms Pontiac LLC
 - 4) Caesars Garden
-
- 5) The Cured Leaf TC Inc
 - 6) Yellow Tail Ventures Inc
 - 7) Larren Investments LLC
 - 8) PGSH Holdings LLC
 - 9) U-Versity Medz
 - 10) Pure Life Solutions II LLC
 - 11) Misty Mee LLC
 - 12) Southeast Provisioning Center LLC
 - 13) Top Hill Compassion Center LLC
 - 14) OP Holdings II LLC
 - 15) The Dixie Depot
 - 16) Prime 7 LLC
 - 17) Herb Wealth LLC

Provisioning Center Application Rankings were announced on March 2, 2021

Note: Rankings are preliminary. They are subject to appeal.

Updated Ranking List was released on May 21, 2021 as a result of Hearing Officer Appeals Round 1

A Fair and Transparent Process

Cesar Chavez Overlay District Provisioning Centers Applications Rankings

Current Ranking List Released on July 6, 2021
as result of Hearing Officer Appeals Round 2

- 1) **Rize Cannabis**
- 2) **West Fort Holdings LLC**

- 3) **Greenhouse Farms Pontiac LLC**
- 3) **Yellow Tail Ventures Inc**
- 5) **The Cured Leaf TC Inc**
- 6) **Caesars Garden**
- 7) **Larren Investments LLC**
- 8) **PGSH Holdings LLC**
- 9) **U-Versity Medz**
- 10) **Pure Life Solutions II LLC**
- 11) **Misty Mee LLC**
- 12) **Southeast Provisioning Center LLC**
- 13) **Top Hill Compassion Center LLC**
- 14) **OP Holdings II LLC**
- 15) **The Dixie Depot**
- 16) **Prime 7 LLC**
- 17) **Herb Wealth LLC**

A Fair and Transparent Process

Medical Marihuana Commission Appeal Form

Application Name _____ Application Number _____

Application Name _____ Application Number _____



CITY OF PONTIAC MEDICAL MARIHUANA COMMISSION

Following a denial of an application by the City Clerk after review by the Hearing Officer, an appellant who wishes to appeal the denial of its application may further appeal to the medical marihuana commission by filing a written statement fully setting forth the grounds for appeal within 30 days after notice of the denial has been mailed to the appellant. Written statements of appeal must be filed by mail or in person with the City Clerk's office. The medical marihuana commission shall only overturn a decision or finding of the City Clerk if it finds such decision or finding to be arbitrary or capricious and not supported by material, substantial, and competent facts on the whole record considered by the City Clerk in arriving at such decision or finding.

Please note the Medical Marihuana Commission is a public body. Any documents that you submit as a part of your appeal to Medical Marihuana Commission are public and subject to disclosure in accordance with the Freedom of Information Act (FOIA). The hearing officer recommendation and the Clerk's decision on your appeal will be submitted to the Medical Marihuana Commission and therefore will subject to public disclosure.

Please use the appeal form below if you are submitting an appeal to the Medical Marihuana Commission. You can only appeal to the Medical Marihuana Commission after you have received a decision letter from the City Clerk about your hearing officer appeal.

**Medical Marihuana Facility Permit Application
Medical Marihuana Commission Appeal Form**

| | | | |
|---|-------|---------------|--|
| Appellant Name (Applicant) | | Address | |
| City | State | Zip Code | |
| Appellant's Representative or Contact Person for Purposes of Appeal | | | |
| Phone Number | | Email Address | |

Written Statement of Appeal
 *If You Require Additional Space, You May Attach An Addendum. All Attachments To This Appeal Form Should Be Clearly Labeled With Your Appellant (Application) Name and Application Number

Appellant Representative or Contact Person
 Print Name _____ Signature _____ Date _____

For Office of the City Clerk Use Only
 Hearing Officer Appeal Hearing Date _____
 Clerk Decision Letter Date _____

A Fair and Transparent Process

Three Applicants Appealed to the Medical Marihuana Commission after they received the Clerk's final decision.

1. The Dixie Depot
2. Larren Investments
3. PGSH Holdings LLC

We are unable to issue conditional approvals for Cesar Chavez until the Medical Marihuana Commission hears the three appeals. The medical marihuana ordinance calls for the Mayor to select the four members of the Commission. Mayor Waterman has not named the commission members. The top five applicants have already been waiting over three months for the appeal process to be concluded.

As soon as the commission hears the appeals, we will be able to issue conditional approvals to the top 5 ranked applicants.



Downtown Overlay District



Types of License Available in this District

- 1) Secure Transporter
- 2) Safety Compliance
- 3) Provisioning Centers (No more than 5 Provisioning Centers will be selected in this district)

A Fair and Transparent Process

Downtown Overlay District Provisioning Centers Applications Rankings

- | | |
|-------------------------------------|---|
| 1. Common Citizen | 18. Greenstone East LLC |
| 1. 3 Green LLC | 19. JNN Property LLC |
| 3. Zenith Ventures LLC | 20. Michigan Supply and Provisions |
| 3. RTMC Enterprises Inc | 21. New Gen Meds |
| 3. RTMC Enterprises Inc | 22. Nature's Medicine |
| 6. Pure Roots LLC | 23. Nature's Medicine |
| 7. Detroit Medical Concepts | |
| 8. Green Bronco III LLC | |
| 9. QPS Michigan Holdings LLC | |
| 10. Pontiac Provisioning LLC | |
| 11. Clean Roots LLC | |
| 12. VB Chesaning | |
| 13. JNN Property LLC | |
| 13. Green Buddha | |
| 15. JDS Brothers LLC | |
| 16. Battle Spring LLC | |
| 16. Green Buddha II LLC | |

Provisioning Center Application Rankings were announced on May 18, 2021

Note: Rankings are preliminary. They are subject to appeal.

A Fair and Transparent Process

Office of the City Clerk Downtown Appeal Process

Pontiac City Clerk makes decision on the provisioning center applications on May 18, 2021



Applicant submits written appeal to Pontiac City Clerk within 14 days by June 1, 2021.



Grewal Law PLLC Appeals Hearing Officer



Hearing officer will conduct hearings on appeals on July 15-16, 2021 and made a recommendation to Pontiac City Clerk, who makes a decision on the matter. The Clerk will issue his final decision.



Applicants may further submit a written appeal to medical marihuana commission within 30 days of receiving the Clerk's final decision.

A Fair and Transparent Process

Walton Blvd Overlay District



Types of License Available in this District

- 1) Grower
- 2) Processor
- 3) Secure Transporter
- 4) Safety Compliance
- 5) Provisioning Centers (No more than 5 Provisioning Centers will be selected in this district)

A Fair and Transparent Process

Non Overlay District

Types of Licenses Available in this District:

Provisioning Centers are permitted in C-1, C-3 and C-4 zones properties located outside of the Cesar Chavez, Downtown and Walton Overlay Districts. (No more than 5 provisioning centers will be selected in the Non-Overlay)

Prior to being issued a permit, the applicant will need to obtain a special exemption permit from the City of Pontiac Planning Commission

Safety Compliance are permitted in C-1, C-3, C-4, M-1 and M-2 zoning districts outside the Medical Marihuana Overlay Districts.

Secure Transporters are permitted in C-1, C-3, C-4, M-1 and M-2 zoning districts outside the Medical Marihuana Overlay Districts.

A Fair and Transparent Process

Growers and Processors are allowed in the Cesar Chavez and Walton Blvd Overlay Districts

Additionally, the City Council approved a conditional rezoning agreement with Rubicon in January 2020 that allows growers and processors to locate at the old Glenwood Plaza site



A Fair and Transparent Process

7) Conditional Approvals for Growers, Processors, Secure Transporters & Safety Compliance

- 4 Growers

1. Pharmaco Inc.
up to 1500 plants
2. PGSH Holdings Inc.
up to 1500 plants
3. Family Rootz LLC
up to 1500 plants
4. Family Rootz LLC
up to 500 plants

- 2 Processors

1. Pharmaco Inc.
2. Family Rootz

Conditional Approval Next Steps

After an applicant receives a conditional approval, they must comply with the following before the City Clerk can issue the applicant a permit to operate per Ordinance 2357(B).

Fire Department (Waterford Regional Fire Department) and Building & Safety Department inspects the proposed location for compliance with all state and local building, electrical, fire, mechanical and plumbing requirements;

Applicant received certificate of occupancy and if necessary, a building permit:

Site plan approval and if necessary a special exemption permit approval from Planning.

Proof of premises liability and casualty insurance.

The applicant has obtained their pre-approval from the State of Michigan.



Conditional Approved - Grower

| Applicant Name | Conditional Approval Issued | Consent to Release Form Received | Building | Fire (Waterford Regional) | Planning Site Plan/Special Exemption (if necessary) | Liability & Casualty Insurance Verified | State Pre-Approval |
|-----------------------|------------------------------------|---|-----------------|----------------------------------|--|--|---------------------------|
| Pharmaco Inc | 6/3/2021 | | | | | | |
| PGSH Holdings LLC | 5/21/2021 | 7/9/2021 | | | | | |
| Family Rootz | 5/27/2021 | 6/19/2021 | | | | | |
| Botanical Greens Inc | 7/19/2021 | 6/22/2021 | | | | | |

Conditional Approved - Processor

| Applicant Name | Conditional Approval Issued | Consent to Release Form Received | Building | Fire (Waterford Regional) | Planning Site Plan/Special Exemption (if necessary) | Liability & Casualty Insurance Verified | State Pre-Approval |
|-----------------------|------------------------------------|---|-----------------|----------------------------------|--|--|---------------------------|
| Pharmaco Inc | 6/3/2021 | | | | | | |
| Family Rootz | 5/27/2021 | 6/19/2021 | | | | | |



8) City Clerk's Citizen Monitoring Taskforce on Medical Marihuana Implementation

The six (6) member volunteer citizen taskforce will assist the Clerk with monitoring the implementation of medical marihuana in the City of Pontiac. The taskforce will meet several times over the next year. The Clerk and taskforce will work to ensure Medical Marihuana Facilities fulfill the commitments that they made to the City and are good neighbors in our community. The taskforce will assist the Clerk in developing a community benefits tracking system.

The six (6) member citizen taskforce will consist of one (1) representative from each of the three overlay districts (Cesar Chavez, Downtown and Walton Blvd. The representative must reside in or near the overlay district they are representing) and three (3) citywide representatives (citywide representatives may reside anywhere in the city).

The Clerk will issue quarterly reports on the progress of the taskforce. The first report is scheduled to be released in October 2021.

Citizen Monitoring Taskforce Members

1. Kirk Bagg – Citywide Representative
2. Iola Miller – Citywide Representative
3. Sue Sinclair – Citywide Representative
4. Jon Valentine – Cesar Chavez Representative
5. Michael Glass – Downtown Representative
6. Vacant – Walton Blvd Representative

The residents were selected after completing an application process that included an interview.



Example of a Conditional Approved Grower & Processor Commitments to Pontiac

• Family Rootz Profile:

• Community Benefits Pledges (Charitable Plans)

- Partnership with Lighthouse of Oakland County with donation of 1% of net sales & encourage employees to organize food and clothing drives
- Partnership with Turning Point Recovery with encouraging our employees to volunteer & provide dollar to dollar matching funds.
- Provide employee dollar to dollar matching funds raised each week to support many other deserving charities within Pontiac.

• Community Outreach and Education Strategies

- Partnership with Neighborhood Watch to enhance security
- Family Rootz Director of Business Affairs & Strategies will attend every public scheduled meeting
- Partnership with Pontiac Regional Chamber (PRC) to improve broader business & cultural activities

• Job Creation and Opportunities

- Creation of 90-100 jobs and goal to have 50% plus of employee based residing in Pontiac
- 5 Full-time (FTE) Cultivators \$65,000 - \$85,000 per year
- 10 Full-time (FTE) Cultivation Supervisors \$45,000 – \$65,000 per year
- 27 Full-time (FTE) Cultivation Trainees \$16.85 per hour
- 1 Full-time (FTE) Clone Specialist \$45,000 - \$65,000 per year
- 2 Full-time (FTE) Extraction Specialists \$45,000 - \$65,000 per year
- 7 Full-time (FTE) Office Staff (salaries vary)
- Competitive benefits packages including health insurance, medical, dental & vision and paid time-off

A Fair and Transparent Process

9) Caregiver Ordinance

City Council requested that the City Attorney draft a caregiver zoning ordinance on July 6, 2021.

City Council is awaiting a draft on the ordinance. City Council is awaiting a report on 1536 North Telegraph a proposed unregulated caregiver site.

10) Proposed Recreational Marijuana Ordinance

City Council requested that the City Attorney draft an opt-in recreational marijuana ordinance on July 6, 2021. The City currently has an opt-out recreational marijuana ordinance.

City Council referred the proposed recreational marijuana ordinance drafted by Pontiac Action Committee to a City Council Finance Subcommittee on July 13, 2021.

There is a proposed ballot initiative that is being circulated in the City that calls for 20 additional dispensaries.

Council needs to act soon on an ordinance in order to avoid having 40 dispensaries in the city. (20 medical provisioning centers and 20 recreational dispensaries). The deadline for the City Council to put a proposed ordinance on the ballot is August 10, 2021. Council will have to approve an ordinance by August 5, 2021 in order to make the deadline.



Questions

A Fair and Transparent Process

#3

RESOLUTION



CITY OF PONTIAC

OFFICIAL MEMORANDUM

Executive Branch

TO: Council President, and City Council Members

FROM: Mayor Deirdre Waterman

DATE: July 23, 2021

RE: Resolution to Approve Medical Marihuana Commission Rules and Regulations

Whereas, Pontiac City Ordinance 2357(B) Section 6(b) requires the City Council to approve the Medical Marihuana Commission Rules and Regulations; and

Whereas, those intended to be sworn in as Medical Marihuana Commissioners have provided letters of support of the attached Rules and Regulations; and

Whereas, the Rules and Regulations must be in place so they can govern the first meeting of the Medical Marihuana Commission;

Now Therefore, the Pontiac City Council has reviewed and hereby approves the attached Medical Marihuana Commission Rules and Regulations.

Attachments



Pontiac Medical Marihuana Commission Rules and Regulations

All meetings of the Medical Marihuana Commission (“Commission”) will be held in compliance with all applicable statutes, including the Open Meetings Act, 1976 PA 267 as amended, and with these rules and regulations.

Commission Membership Requirements

Members of the Commission shall be residents of the City of Pontiac and shall serve without pay.

Commission Powers and Duties

The Commission shall review and decide all appeals that are forwarded to it by the City Clerk pursuant to Ordinance 2357(B). The Commission shall review all appeals de novo. The Commission may overturn a decision or finding of the City Clerk if it finds such decision or finding to be arbitrary or capricious and not supported by material, substantial, and competent facts on the whole record considered by the City Clerk in arriving at such decision or finding.

Meeting Schedule

The Committee shall post a meeting notice in a manner consistent with applicable law subsequent to receiving an appeal forwarded to it by the City Clerk pursuant to City Ordinance 2357(B). Due to the timing irregularity of the receipt of appeals, the Commission may not schedule Regular Meetings as set forth in the Michigan Open Meetings Act, Michigan Public Act 267 of 1976, at MCL 15.265. If the Commission does adopt a regular meeting schedule, it shall be posted in a manner consistent with MCL 15.265.

Minutes of meetings

Minutes of all meetings of the Commission shall be kept in a manner consistent with applicable law. A copy of the minutes of meetings shall be available for public inspection at the City Clerk's Office during regular business hours.

Conduct of meetings

All meetings of the Commission shall be open to the public except as permitted by applicable law. All open meetings shall be open to the media, freely subject to recording by radio, television and photographic services at any time, provided that such arrangements do not interfere with the orderly conduct of the meetings.

Commission meeting agenda

Meeting agendas will be as follows

1. Call to order
2. Pledge of Allegiance
3. Roll Call
4. Amendments to and approve of the agenda
5. Approval of the Minutes (As needed)
6. Agenda Items
7. Public Comment (3 Minute Limit)
8. Adjournment

Quorum

A majority of the Commission shall constitute a quorum for the review of appeals.

Chairperson and Vice Chairperson

At its first meeting, the Commission shall select, by majority vote, a Chairperson and Vice Chairperson.

Presiding Officer

The Presiding Officer shall be responsible for enforcing these Rules and Regulations and for enforcing orderly conduct at meetings. The Chairperson shall be the Presiding Officer. If the Chairperson is absent, the Vice Chairperson shall act as the Presiding Officer. In the event of a resignation or other permanent absence of the Chairperson or Vice Chairperson position, it shall be filled by nomination and majority vote of the Commission members serving.

Disorderly conduct

The Presiding Officer may call to order any person who is being disorderly by speaking out of order or otherwise disrupting the proceedings, failing to be germane, speaking longer than the allotted time or speaking vulgarities. Such person shall be seated until the Presiding Officer determines the person is in order.

Closed sessions

Closed sessions may be held only for the reasons consistent with applicable law, as determined by the City Attorney.

Calling closed sessions

The Commission by a two-thirds roll call vote may call a closed session subject to the conditions herein. The roll call vote and purpose(s) for calling the closed meeting shall be entered into the minutes of the public part of the meeting at which the vote is taken.

Minutes of closed meetings

A separate set of minutes shall be taken at the closed session. These minutes will be retained by the City Clerk and shall not be available to the public.

Discussion and voting

Rules of parliamentary procedure

The rules of parliamentary practice, as contained in the 11th edition of Robert's Rules of Order, shall govern the council in all cases to which they are applicable, provided they are not in conflict with these rules, city ordinances or applicable state statutes. The Presiding Officer shall preserve order and decorum and may speak to points of order in preference to other members. If a point of order is given it should not exceed two (2) minutes.

Conduct of discussion

During the council discussion and debate, no member shall speak until recognized for that purpose by the Presiding Officer. After such recognition, the member shall confine discussion to the question at hand and to its merits and shall not be interrupted except by a point of order or privilege raised by another member. Speakers should address their remarks to the chair, maintain a courteous tone and avoid interjecting a personal note into debate.

Public comment

Each meeting agenda shall provide reserved time for public comment participation. During public comment, each individual shall be limited to three (3) minutes, and shall not engage in conduct or language that disrupts, makes fun of, or otherwise impedes the orderly conduct of the meeting. In addition, members of the audience shall not engage in disorderly or boisterous activity including but not limited to; the utterance of loud, obnoxious, threatening, or abusive language, cheering, whistling, or any other acts that disturb, disrupt, or impede, or otherwise interfere with the orderly conduct of the meeting.

Suspension of rules

The rules of the Commission may be suspended for a specified portion of a meeting by an affirmative vote of two-thirds of the members present except that council actions shall conform to applicable law.

#4

**COMMUNICATION
FROM THE CITY
CLERK**



OFFICE OF THE CITY CLERK
MEDICAL MARIHUANA DIVISION

47450 Woodward Avenue
Pontiac, Michigan 48342
Phone: (248) 758-3200
Fax: (248) 758-3160

MEMORANDUM

TO: Honorable City Council

FR: Garland Doyle, M.P.A.
Interim City Clerk

DA: July 22, 2021,

RE: Adoption of Medical Marihuana Commission Rules and Regulations Prior to the Medical Marihuana Commission Approval violates Ordinance 2357(B)

According to Ordinance 2357(B) City of Pontiac Medical Marihuana Facilities Ordinance Section 6

- (a) "The medical marihuana commission shall adopt such rules and regulations as it deems necessary to govern its proceedings and deliberations."
- (b) "The rules and regulations adopted by the medical marihuana commission shall be subject to approval by the council."

If the City Council approves the rules and regulations prior to the medical marihuana commission adopting them would be a violation of Ordinance 2357(B).

Furthermore, the Ordinance 2357(B) Section 6(c) states the following

- (c) "The commission shall maintain a written record of its proceedings and actions which shall be available for public inspection, showing the action of the commission and the vote of each member upon each question considered. All meetings of the commission shall be held in conformance with the open meetings act, Act. No. 267 of the Public Acts of 1976, being sections 15.261 to 15.275 of the Michigan Compiled Laws."

If the commission is required to conduct its business in public, then how can rules be established before the commission has a meeting and commissioners are named.

Mayor Waterman has not revealed the names of the four (4) commissioners.

**Medical Marihuana Commission Rules and Regulations Approval
Process according to Ordinance 2357(B)**

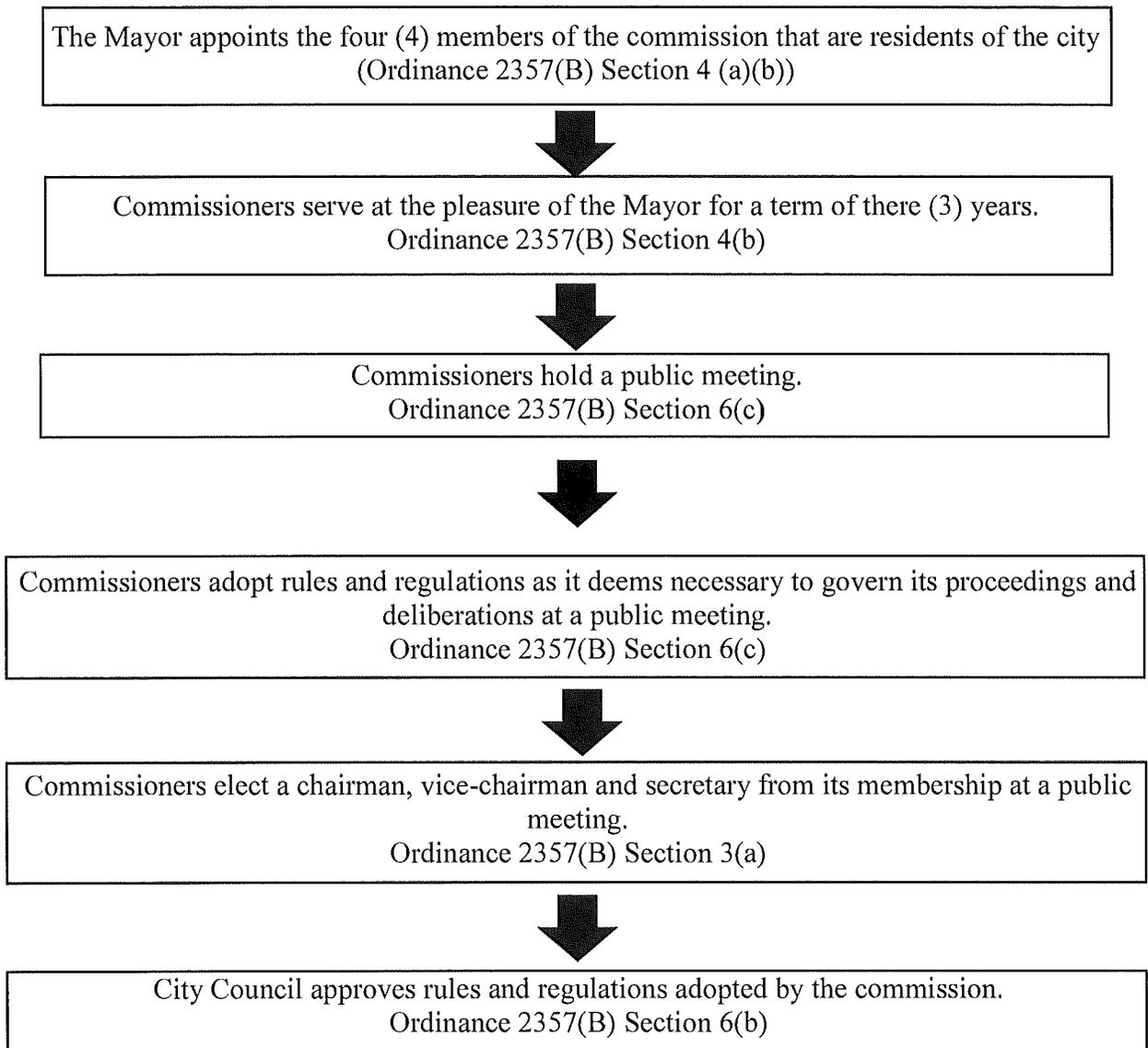

Council cannot approve rules prior to the commission developing and approving them. This would be a violation of the ordinance. If the process is not followed, decisions of the Commission may be invalid.

City Clerk's comments on rules developed by the City Attorney

Although Ordinance 2357(B) is clear that the Commission must develop its rules, there are three major problems with the City Attorney proposed rules.

1. The rules make no reference to the secretary position as required by Ordinance 2357(B) section

2. Closed Session

The City Attorney proposed rules state that closed sessions may be held only for the reasons consistent with applicable law, as determined by the City Attorney.

The Open Meeting Act 15.268 Sec. 8 states the permissible purposes of closed sessions.

15.268 Closed sessions; permissible purposes.

Sec. 8 a public body may meet in a closed session only for the following purposes:

Not Applicable



(a) To consider the dismissal, suspension, or disciplining of, or to hear complaints or charges brought against, or to consider a periodic personnel evaluation of, a public officer, employee, staff member, or individual agent, if the named individual requests a closed hearing. An individual requesting a closed hearing may rescind the request at any time, in which case the matter at issue must be considered after the rescission only in open sessions.

Not Applicable



(b) To consider the dismissal, suspension, or disciplining of a student if the public body is part of the school district, intermediate school district, or institution of higher education that the student is attending, and if the student or the student's parent or guardian request a closed hearing.

Not Applicable



(c) For strategy and negotiating sessions connected with the negotiation of a collective bargaining agreement if either negotiating party requests a closed hearing.

Not Applicable



(d) To consider the purchase or lease of real property up to the time an option to purchase or lease that real property obtained.

(e) To consult with its attorney regarding trial or settlement strategy in connection with specific pending litigation, but only if an open meeting would have a detrimental financial effect on the litigating or settlement position of the public body.

Since section 8(e) is the only applicable section to go into a closed session, than that should be stated in the rules.

HAVING CLOSED SESSIONS IS WHAT GOT THE CITY OF WARREN IN TROUBLE AND LED TO NUMEROUS LAWSUITS. PONTIAC DOES NOT WANT TO MAKE WARREN'S MISTAKE.

3. In the discussion and voting and the conduct of discussion sections of the rules, there are several references made to council when it should state commission.

CITY OF PONTIAC ORDINANCE NO. #2357(B)

An ordinance to allow medical marihuana facilities to operate in the City of Pontiac pursuant to the Medical Marihuana Facilities Licensing Act, Act No. 281 of the Public Acts of 2016; to provide for standards and procedures to permit and regulate medical marihuana facilities; to provide for the imposition of permit application fees; and to impose conditions for the operation of medical marihuana facilities.

The City of Pontiac ordains:

Section 1. Title.

The title of this ordinance shall be the "City of Pontiac Medical Marihuana Facilities Ordinance."

Section 2. Definitions.

The following words, terms and phrases, when used in this article, shall have the meanings ascribed to them in this except where the context clearly indicates a different meaning:

Applicant means a person who applies for a permit to operate a medical marihuana facility under this ordinance.

Board means the State of Michigan Medical Marihuana Licensing Board.

Class A grower means a grower licensed to grow not more than 500 marihuana plants.

Class B grower means a grower licensed to grow not more than 1,000 marihuana plants.

Class C grower means a grower licensed to grow not more than 1,500 plants.

Department means the State of Michigan Department of Licensing and Regulatory Affairs or its successor agency.

Disqualifying felony means a felony that makes an individual ineligible to receive a license under the MMFLA.

Grower means a commercial entity that cultivates, dries, trims, or cures and packages marihuana for sale to a processor or provisioning center. As used in this ordinance, grower shall include class A growers, class B growers, and class C growers.

License means a license that is issued under the MMFLA that allows the licensee to operate as a grower, processor, secure transporter, provisioning center, or safety compliance facility.

Marihuana-infused product means a topical formulation, tincture, beverage, edible substance, or similar product containing any usable marihuana that is intended for human consumption in a manner other than smoke inhalation. Marihuana-infused products shall not be considered a food for purposes of the food law, Act No. 92 of the Public Acts of 2000, being sections 289.1101 to 289.8111 of the Michigan Compiled Laws.

Medical marihuana facility means a location at which a grower, processor, provisioning center, secure transporter, or safety compliance facility is licensed to operate under the MMFLA.

MMFLA means the Medical Marihuana Facilities Licensing Act, Act No. 281 of the Public Acts of 2016, being sections 333.27101 to 333.27801 of the Michigan Compiled Laws.

MMMA means the Michigan Medical Marihuana Act, Initiated Law 1 of 2008, being sections 333.26421 to 333.26430 of the Michigan Compiled Laws.

Permittee means a person who receives a permit to operate a medical marihuana facility under this ordinance.

Processor means a commercial entity that purchases marihuana from a grower and that extracts resin from the marihuana or creates a marihuana-infused product for sale and transfer in packaged form to a provisioning center.

Provisioning center means a commercial entity that purchases marihuana from a grower or processor and sells, supplies, or provides marihuana to registered qualifying patients, directly or through the patients' registered primary caregivers. Provisioning center includes any commercial property where marihuana is sold at retail to registered qualifying patients or registered primary caregivers. A noncommercial location used by a primary caregiver to assist a qualifying patient connected to the caregiver through the department's marihuana registration process in accordance with the MMMA is not a provisioning center for purposes of this ordinance.

Registered primary caregiver means a person who is at least 21 years old and who has agreed to assist with a patient's medical use of marihuana and who has a valid registry identification card.

Registered qualifying patient means a person who has been diagnosed by a physician as having a debilitating medical condition and has a valid registry identification card.

Registry Identification card means a document issued by the department that identifies a person as a registered qualifying patient or registered primary caregiver.

Safety compliance facility means a commercial entity that receives marihuana from a medical marihuana facility or registered primary caregiver, tests it for contaminants and for tetrahydrocannabinol and other cannabinoids, returns the test results, and may return the marihuana to the medical marihuana facility.

Secure transporter means a commercial entity located in this state that stores marihuana and transports marihuana between medical marihuana facilities for a fee.

Stakeholder means with the officers, directors, and managerial employees of an applicant and any persons who hold any direct or indirect ownership interest in the applicant

Section 3. Creation of Medical Marihuana Commission; Composition; Quorum.

(a) There is hereby created a medical marihuana commission. There shall be four (4) members of the medical marihuana commission. The membership shall elect from among its members a chairman, vice-chairman, and secretary.

(b) A quorum of the medical marihuana commission shall consist of three (3) members.

Section 4. Medical Marihuana Commission Membership; Qualifications; Term; Vacancies; Compensation.

(a) Members of the medical marihuana commission shall be residents of the city, and shall be chosen so far as reasonably practicable in such a manner as to represent a cross-section of the community.

(b) Members of the medical marihuana commission shall be appointed by the mayor to serve at the pleasure of the mayor for a term of three (3) years. Reappointment of a member to serve an additional consecutive term is subject to council approval.

(c) If a vacancy occurs on the medical marihuana commission, the mayor shall appoint a new member to fill the vacancy.

(d) Members of the medical marihuana commission shall serve without pay.

Section 5. Medical Marihuana Commission Powers and Duties.

The medical marihuana commission shall review and decide all appeals that are forwarded to it by the clerk under this ordinance. The medical marihuana commission shall review all appeals de novo. The medical marihuana commission shall only overturn a decision or finding of the clerk if it finds such decision or finding to be arbitrary or capricious and not supported by material, substantial, and competent facts on the whole record considered by the clerk in arriving at such decision or finding.

Section 6. Medical Marihuana Commission Rules and Regulations; Meetings.

(a) The medical marihuana commission shall adopt such rules and regulations as it deems necessary to govern its proceedings and deliberations.

(b) The rules and regulations adopted by the medical marijuana commission shall be subject to approval by the council.

(c) The commission shall maintain a written record of its proceedings and actions which shall be available for public inspection, showing the action of the commission and the vote of each member upon each question considered. All meetings of the commission shall be held in conformance with the open meetings act, Act. No. 267 of the Public Acts of 1976, being sections 15.261 to 15.275 of the Michigan Compiled Laws.

Section 7. Medical Marijuana Facility Rules and Regulations.

(a) In addition to the rules promulgated by the department and the statutes of the State of Michigan, the operation of medical marijuana facilities shall be made in accordance with the provisions of this ordinance.

(b) Medical marijuana provisioning centers shall be closed for business, and no sale or other distribution of marijuana in any form shall occur upon the premises between the hours of 10:00 p.m. and 7:00 a.m.

Section 8. Medical Marijuana Facility Applications.

(a) No person shall operate a medical marijuana facility in the city without first obtaining a permit for the medical marijuana facility from the city and obtaining a license from the department

(b) In addition to such applications as may be required by the department for licensing by the State of Michigan, application shall be made to the clerk to operate a medical marijuana facility in the city.

(c) Applications shall be made on forms provided by the clerk, shall be signed by the applicant, if an individual, or by a duly authorized agent thereof, if an entity, verified by oath or affidavit, and seal if available, and shall contain all of the following:

(1) The full name, date of birth, physical address, email address, and telephone number of the applicant in the case of an individual; or, in the case of an entity, all stakeholders thereof.

(2) If the applicant is an entity, the entity's articles of incorporation or organizational documents.

(3) If the applicant is an entity, the entity's employee identification number.

(4) If the applicant is an entity, the entity's operating agreement or bylaws.

(5) A written description of the training and education that the applicant will provide to all employees.

- (6) A copy of the proposed business plan for the applicant.
- (7) The proposed ownership structure of the entity that identifies the ownership percentage held by each stakeholder.
- (8) A current organization chart that includes position descriptions and the names of each person holding such position.
- (9) A proposed marketing, advertising, and business promotion plan for the proposed medical marijuana facility.
- (10) A description of planned tangible capital investment in the city, including detail related to the number and nature of proposed medical marijuana facilities, and whether the locations of such facilities will be owned or leased.
- (11) An explanation of the economic benefits to the city and job creation to be achieved, including the number and type of jobs the medical marijuana facility is expected to create, the amount and type of compensation expected to be paid for such jobs, and the projected annual budget and revenue of the medical marijuana facility.
- (12) A description of the financial structure and financing for the proposed medical marijuana facility.
- (13) Short-term and long-term business goals and objectives for the proposed medical marijuana facility.
- (14) A criminal background report of the applicant's criminal history. Such reports shall be obtained by the applicant through the Internet Criminal History Access Tool (ICHAT) for applicants residing in Michigan and/or through another state sponsored or authorized criminal history access source for applicants who reside in other states or have resided in other states within 5 years prior to the date of the application. The applicant is responsible for all charges incurred in requesting and receiving the criminal history report and the report must be dated within thirty (30) days of the date of the application.
- (15) A description of proposed community outreach and education strategies.
- (16) A description of proposed charitable plans, whether through financial donations or volunteer work.
- (17) A description of the security plan for the proposed medical marijuana facility that is consistent with the requirements of the department.
- (18) A floor plan of the proposed medical marijuana facility.

- (19) A scale diagram illustrating the property upon which the proposed medical marihuana facility is to be operated, including all available parking spaces, and specifying which parking spaces are handicapped-accessible.
- (20) A depiction of any proposed text or graphic materials to be shown on the exterior of the proposed medical marihuana facility.
- (21) A facility sanitation plan that describes how waste will be stored and disposed and how marihuana will be rendered unusable upon disposal at the proposed medical marihuana facility.
- (22) A proposed inventory and recordkeeping plan consistent with the requirements of the department.
- (23) An affidavit that neither the applicant nor any stakeholder of the applicant is in default to the city.
- (24) Verification that the applicant has a minimum capitalization consistent with the requirements of the department.
- (25) Proof of premises liability and casualty insurance consistent with the requirements of the department.
- (26) A signed acknowledgement that the applicant understands that all matters related to marihuana cultivation, possession, dispensing, testing, transporting, distribution and use are currently subject to federal laws, and that the approval of a permit hereunder does not exonerate or exculpate the applicant from exposure to any penalties associated therewith. Further, the applicant completely releases and forever discharges the city and its respective employees, agents, facilities, insurers, indemnors, successors, heirs and/or assigns from any and all past, present or future claims, demands, obligations, actions, causes of action, wrongful death claims, rights, damages, costs, losses of services, expenses and compensation of any nature whatsoever, whether based on a tort, contract or other theory or recovery, which the applicant or its stakeholders may now have, or which may hereafter accrue or otherwise be acquired, on account of, or may in any way arise out of the applicant or stakeholders' application for a permit and, if issued a permit, the applicant or stakeholders' operation of a medical marihuana facility.
- (27) A location area map that identifies the relative locations of, and distances from, the nearest school, childcare center, public park containing playground equipment, or religious institution, as measured along the centerline of the street or streets of address between two fixed points on the centerline determined by projecting straight lines, at right angles to the centerline, from the primary point of ingress to the school, childcare center, or religious institution, or, for a public park, from the playground equipment nearest to contemplated location, and from the primary point of ingress to the contemplated location.

(28) If the applicant is applying for a permit to operate a provisioning center, a patient education plan consistent with the requirements of the department.

(29) If the applicant is applying for a permit to operate a provisioning center, a description of any drug and alcohol awareness programs that shall be provided or arranged for by the applicant and made available to the public.

(30) If the applicant is applying for a permit to operate a grower, a cultivation plan that includes a description of the cultivation methods to be used, including whether the grower plans to grow outdoors consistent with the rules promulgated by the department.

(31) If the applicant is applying for a permit to operate a grower, a chemical and pesticide storage plan that is consistent with the requirements of the department

(d) All applications must be accompanied by the appropriate fee to help defray administrative costs associated with the application for the medical marihuana facility, which shall be set by a resolution adopted by council, but shall not exceed five thousand dollars (\$5,000.00) per application.

(e) An applicant may apply for multiple medical marihuana facility permits of the same or different nature.

Section 9. Medical Marihuana Facility Application Process.

(a) Upon receipt of a completed application meeting the requirements of this ordinance and the appropriate permit application fee, the clerk shall refer a copy of the application to the fire department and the department of building safety & planning.

(b) No application shall be approved for a permit unless:

(1) The fire department and the department of building safety & planning or another relevant department have inspected the proposed location for compliance with all state and local building, electrical, fire, mechanical and plumbing requirements.

(2) The department of building safety & planning or another relevant department has confirmed that the proposed location complies with the zoning ordinance.

(3) The proposed medical marihuana facility has been issued a certificate of occupancy and, if necessary, a building permit

(c) After this ordinance becomes effective, the clerk shall begin accepting medical marihuana facility applications within 60 days. Within 7 days of the date the clerk begins accepting medical marihuana facility permit applications, the clerk must set a 21- day application period during which applicants may apply for a permit to operate a provisioning center.

(d) The clerk shall award a permit to any applicant for a permit to operate a grower, processor, secure transporter, or safety compliance facility who submits a complete application, receives the approvals required in this section, and meets the requirements of this ordinance.

(e) The clerk shall assess, evaluate, score and rank all applications for permits to operate a provisioning center submitted during the twenty-one (21) day application period set forth in this section.

(f) In its application assessment, evaluation, scoring, ranking, and deliberations related to permits to operate a provisioning center, the clerk shall assess, evaluate, score, and rank each application based upon a scoring and ranking procedure developed by the clerk consistent with the requirements, conditions, and provisions of this ordinance in each of the following categories:

(1) The content and sufficiency of the information required to be in the application under this ordinance. The maximum number of scoring points in this category shall be fifty (50) points.

(2) Whether the proposed medical marijuana facility will be consistent with land use for the surrounding neighborhood and not have a detrimental effect on traffic patterns and resident safety. The maximum number of scoring points in this category shall be twenty (20) points.

(3) Planned outreach on behalf of the proposed medical marijuana facility, and whether the applicant or its stakeholders have made, or plan to make, significant physical improvements to the building housing the proposed medical marijuana facility, including plans to eliminate or minimize traffic, noise, and odor effects on the surrounding neighborhood. The maximum number of scoring points in this category shall be ten (10) points.

(4) Whether the applicant or any of its stakeholders have a record of acts detrimental to the public health, security, safety, morals, good order, or general welfare prior to the date of the application. The maximum number of scoring points in this category shall be ten (10) points. If an applicant and all of its stakeholders have received prequalification approval from the department or board, the applicant shall receive the maximum number of scoring points under this category.

(5) Whether the applicant has reasonably and tangibly demonstrated it possesses sufficient financial resources to fund, and the requisite business experience to execute, the submitted business plan and other plans required this ordinance. The maximum number of scoring points in this category shall be ten (10) points. If an applicant and all of its stakeholders have received prequalification approval from the department or board, the applicant shall receive the maximum number of scoring points under this category.

(6) The number of full-time and part-time positions the applicant intends to create; the hourly wages or salaries the applicant intends to pay employees; whether the applicant has articulated plans and strategies to attract and hire employees from the City of Pontiac; and

whether the applicant has articulated plans to provide employee health and welfare benefit plans, including, but not limited to, sick leave, maternity leave, and paternity leave. The maximum number of scoring points in this category shall be ten (10) points.

(7) Planned philanthropic endeavors and community improvement programs aimed at the City of Pontiac. The maximum number of scoring points in this category shall be ten (10) points.

(8) The proximity of the proposed medical marijuana facility to other structures, including whether the proposed medical marijuana facility is more than 1,000 feet from an operational public or private school and more than 500 feet from an operational commercial childcare organization (non-home occupation) that is licensed or registered with the State of Michigan Department of Health and Human Services or its successor agency, a public park with playground equipment, or a religious institution that is defined as tax exempt by the city assessor. Such distance between the school, childcare center, public park, or religious institution and the contemplated location shall be measured along the centerline of the street or streets of address between two fixed points on the centerline determined by projecting straight lines, at right angles to the centerline, from the primary point of ingress to the school, childcare center, or religious institution, or from the playground equipment in a public park, and from the primary point of ingress to the contemplated location. The maximum number of scoring points in this category shall be ten (10) points.

(g) Overall scoring and ranking shall be conducted and applied by the clerk on the basis of assigned points from zero (0) points to one hundred and thirty (130) points with the lowest overall total score as zero (0) points and the highest possible total score being one hundred and thirty (130) points.

(h) At the conclusion of the twenty-one (21) day application period, the clerk shall begin processing applications for permits to operate provisioning centers, awarding permits to the twenty (20) highest scoring applicants. In the event of an evaluation scoring tie, which causes there to be more than twenty (20) applicants who achieve scores sufficient to qualify for a permit, the scoring-tied applicants will be entered into a random draw. Those applications randomly selected shall be eligible to receive a permit to operate a provisioning center. In the event that the number of provisioning center permits subsequently falls below the maximum number authorized under this ordinance, the clerk shall not be required to score applicants. Instead, the clerk shall evaluate applications in the order that they are submitted and shall award permits for provisioning centers to an applicant who submits a complete application, receives the approvals required in this section, and meets the requirements of this ordinance. However, in no event shall the number of provisioning center permits exceed the maximum number authorized under this ordinance.

(i) Nothing in this section is intended to confer a property or other right, duty, privilege or interest in a permit of any kind or nature whatsoever including, but not limited to, any claim of entitlement.

(j) The clerk may engage professional expert assistance in performing the clerk's duties and responsibilities under this ordinance.

Section 10. Medical Marihuana Facility Permit limitations.

There shall be no limit on the number of permits issued by the city for growers, processors, secure transporters, or safety compliance facilities. The city shall issue twenty (20) provisioning center permits or a number of provisioning center permits equal to the number of complete provisioning center permit applications that meet the requirements of this ordinance and are submitted during the twenty-one (21) day period, whichever number is less.

Section 11. Medical Marihuana Facility Co-Location and Stacking.

(a) Consistent with the MMFLA and rules promulgated by the department, any combination of growers, processors, and provisioning centers may operate as separate medical marihuana facilities at the same physical location.

(b) Consistent with the MMFLA and rules promulgated by the department, applicants for class C grower permits shall be allowed to receive multiple such permits and operate under each permit in a single facility.

Section 12. Transfer of Existing Medical Marihuana Facility Permits.

(a) Permittees may transfer a permit issued under this ordinance to a different location upon receiving written approval from the clerk and the department or the board pursuant to the MMFLA and rules promulgated by the department. In order to request municipal approval to transfer a permit location, the permittee must make a written request to the clerk, indicating the current location of the medical marihuana facility and the proposed new location. Upon receiving the written request, the clerk shall refer a copy of the written request to the fire department and the department of building safety & planning or another appropriate department. No permit transfer shall be approved unless each such department or entity gives written approval that the proposed permit location meet the standards identified in this ordinance and the department or board approves the transfer.

(b) Permittees may transfer a permit issued under this ordinance to a different individual or entity upon receiving written approval from the clerk and the department or the board pursuant to the MMFLA and rules promulgated by the department. In order to request municipal approval to transfer a permit to a different individual or entity, the permittee must make a written request to the clerk, indicating the current permittee and the proposed permittee. The clerk shall grant the request so long as the department or board authorizes the transfer pursuant to the MMFLA and rules promulgated by the department.

Section 13. Term of Medical Marihuana Facility Permit

(a) Each permit shall be displayed in a conspicuous spot in the building for that current year.

(b) A permittee shall remove any expired permit on display and replace it with the current permit. A permittee shall not attempt nor act in any fraudulent manner in regard to the display of any permit.

(c) Approval of a permit shall be for a period of one calendar year subject to review by the clerk upon continued compliance with the regulations of this article.

Section 14. Annual Medical Marihuana Facility Permit Renewal.

(a) Application for a permit renewal shall be made in writing to the clerk at least 30 days prior to the expiration of an existing permit.

(b) An application for a permit renewal required by this ordinance shall be made under oath on forms provided by the clerk, and shall contain all of the information required in an initial application.

(c) An application for a permit renewal shall be accompanied by a renewal fee to help defray administrative and enforcement costs associated with the operation of the medical marihuana facility, which shall be set by resolution of the council, but shall not exceed five thousand dollars (\$5,000.00).

(d) Upon receipt of a completed application for a permit renewal meeting the requirements of this ordinance and the permit renewal fee, the clerk shall refer a copy of the renewal application to the fire department and the department of building safety & planning.

(e) No application for a permit renewal shall be approved unless:

(1) The fire department and the department of building safety & planning or another relevant department have, within the past calendar year, inspected the proposed location for compliance with all state and local building, electrical, fire, mechanical and plumbing requirements.

(2) The department of building safety & planning or another relevant department has confirmed that the location complied with the zoning ordinance at the time the permit was granted.

(3) The permittee possesses the necessary state licenses or approvals, including those issued pursuant to the MMFLA.

(4) The applicant has operated the medical marihuana facility in accordance with the conditions and requirements of this ordinance.

(5) The permittee is operating the medical marihuana facility in accordance with State of Michigan laws and rules and this ordinance, and has not been declared a public nuisance.

(f) If written approval is given by each department or entity identified in this section, the clerk shall issue a permit renewal to the applicant. The renewal shall be deemed approved if the city has not issued formal notice of denial within 60 days of the filing date of the application.

Section 15. Revocation or Suspension of Medical Marihuana Facility Permit

Each medical marihuana facility within the city for which a permit is granted shall be operated and maintained in accordance with all applicable laws, rules, and regulations. Upon any violation of this section or any section of this ordinance, the clerk may, after a notice and hearing, revoke or suspend such permit as hereinafter provided.

Section 16. Procedure for Denial, Recommendation of Nonrenewal, Suspension, or Revocation of Medical Marihuana Facility Permit

The clerk shall notify an applicant of the reasons for denial of an application for a permit or permit renewal or for revocation of a permit or any adverse decision under this ordinance and provide the applicant or permittee with the opportunity to be heard. Any applicant or permittee aggrieved by the denial or revocation of a permit or adverse decision under this ordinance may appeal to the clerk, who shall appoint a hearing officer to hear and evaluate the appeal and make a recommendation to the clerk. Such appeal shall be taken by filing with the clerk, within fourteen (14) days after notice of the action complained of has been mailed to the applicant or permittee's last known address on the records of the clerk, a written statement setting forth fully the grounds for the appeal. The clerk shall review the report and recommendation of the hearing officer and make a decision on the matter. The clerk's decision may be further appealed to the medical marihuana commission if applied for in writing to the medical marihuana commission no later than thirty (30) days after the clerk's decision. The review on appeal of a denial or revocation or adverse action shall be by the medical marihuana commission pursuant to this ordinance. Any decision by the medical marihuana commission on an appeal shall be final for purposes of judicial review. The clerk may engage professional experts to assist with the proceedings under this section.

Section 17. Criteria for Denial, Nonrenewal, Suspension, or Revocation of Medical Marihuana Facility Permit.

In addition to any other reasons set forth in this ordinance, the city may refuse to issue a permit or grant renewal of the permit or suspend or revoke the permit pursuant to Pontiac City Ordinance section 1-24 or for any of the following reasons:

- (1) A material violation of any provision of this ordinance.
- (2) Any conviction of a disqualifying felony by the permittee or any stakeholder of the permittee.
- (3) Failure of the permittee or the medical marihuana facility to obtain or maintain a license from the state pursuant to the MMFLA.

Section 18. Penalties.

Any person in violation of any provision of this ordinance, including the operation of a medical marihuana facility without a permit issued pursuant to this ordinance, shall be subject to a five hundred dollar (\$500.00) civil fine and costs. Each day of a violation may be considered a separate violation.

Section 19. Severability; Conflicts.

(a) If any section, clause, or provision of this ordinance shall be declared to be unconstitutional, void, illegal, or ineffective by any court of competent jurisdiction, such section, clause, or provision declared to be unconstitutional, void, or illegal shall thereby cease to be a part of this ordinance, but the remainder of this ordinance shall stand and be in full force and effect.

(b) If any section, clause, or provision of this ordinance is determined by a court of competent jurisdiction to conflict with the MMFLA, state law, or rules promulgated by the department, the MMFLA, state law, or rules shall control.

Section 20. Repealer.

All ordinances or parts of ordinances in conflict herewith are hereby repealed only to the extent necessary to give this ordinance full force and effect.

Following a recount on September 12, 2018 from the August 7, 2018 Election, the following ordinance was adopted.

I hereby certify that the foregoing is a true copy of the Ordinance passed by the Citizens of Pontiac during an Election on August 7, 2018 and recount on September 12, 2018.

Sheila R. Grandison, Acting City Clerk

#5

**SPECIAL
PRESENTATION**

A TOWN HALL MEETING



PONTIAC IS RECEIVING \$37.7 MILLION FROM THE AMERICAN RESCUE PLAN LETS TALK ABOUT HOW TO SPEND THIS MONEY TO BENEFIT THE CITY, RESIDENTS AND BUSINESSES.

MAYOR WATERMAN IS HOSTING A TOWN HALL IN YOUR DISTRICT. THE MAYOR WANTS YOUR INPUT AND COLLABORATION

Using the funds to help our citizens and businesses, and to continue Pontiac's progress, Mayor Waterman has made recommendations to the city council for the following uses:

- 1** Restore Neighborhoods
- 2** Citizen Relief
- 3** Infrastructure Improvements
- 4** Public Safety

Watch for a listing of a date and location in your district.

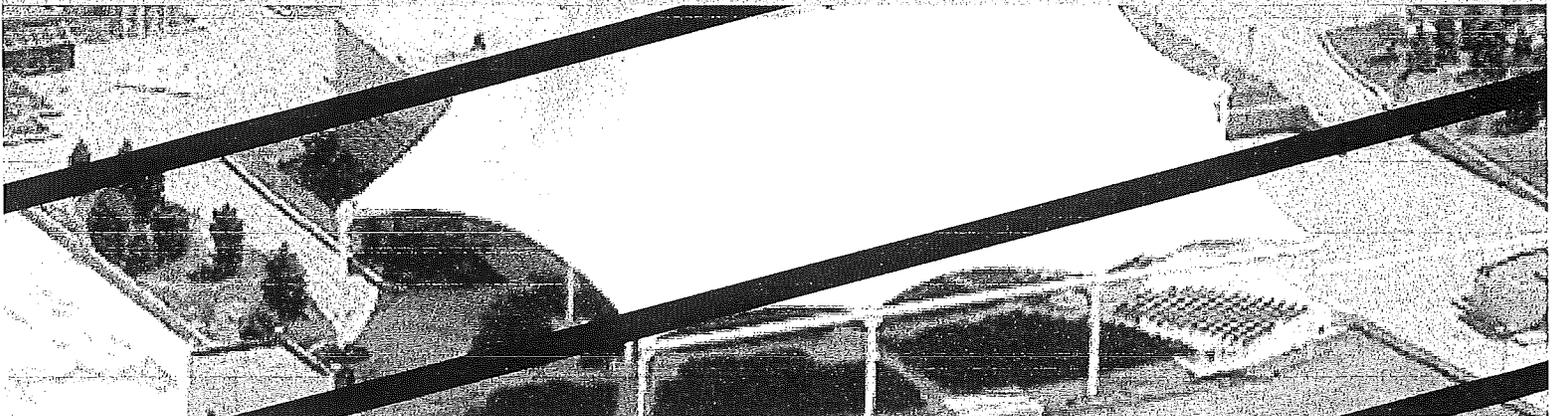

SAVE THE DATE

State of the City Address: Then, Now, & Future Vision

June 28th, 2021 - Phoenix Center Amphitheater

Free to the Public - Light Refreshments Provided



FACT SHEET: The Coronavirus State and Local Fiscal Recovery Funds Will Deliver \$350 Billion for State, Local, Territorial, and Tribal Governments to Respond to the COVID-19 Emergency and Bring Back Jobs

May 10, 2021

Aid to state, local, territorial, and Tribal governments will help turn the tide on the pandemic, address its economic fallout, and lay the foundation for a strong and equitable recovery

Today, the U.S. Department of the Treasury announced the launch of the Coronavirus State and Local Fiscal Recovery Funds, established by the American Rescue Plan Act of 2021, to provide \$350 billion in emergency funding for eligible state, local, territorial, and Tribal governments. Treasury also released details on how these funds can be used to respond to acute pandemic response needs, fill revenue shortfalls among these governments, and support the communities and populations hardest-hit by the COVID-19 crisis. With the launch of the Coronavirus State and Local Fiscal Recovery Funds, eligible jurisdictions will be able to access this funding in the coming days to address these needs.

State, local, territorial, and Tribal governments have been on the frontlines of responding to the immense public health and economic needs created by this crisis – from standing up vaccination sites to supporting small businesses – even as these governments confronted revenue shortfalls during the downturn. As a result, these governments have endured unprecedented strains, forcing many to make untenable choices between laying off educators, firefighters, and other frontline workers or failing to provide other services that communities rely on. Faced with these challenges, state and local governments have cut over 1 million jobs since the beginning of the crisis. The experience of prior economic downturns has shown that budget pressures like these often result in prolonged fiscal austerity that can slow an economic recovery.

To support the immediate pandemic response, bring back jobs, and lay the groundwork for a strong and equitable recovery, the American Rescue Plan Act of 2021 established the Coronavirus State and Local Fiscal Recovery Funds, designed to deliver \$350 billion to state, local, territorial, and Tribal governments to bolster their response to the COVID-19 emergency and its economic impacts. Today, Treasury is launching this much-needed relief to:

- Support urgent COVID-19 response efforts to continue to decrease spread of the virus and bring the pandemic under control;
- Replace lost public sector revenue to strengthen support for vital public services and help retain jobs;
- Support immediate economic stabilization for households and businesses; and,
- Address systemic public health and economic challenges that have contributed to the inequal impact of the pandemic on certain populations.

The Coronavirus State and Local Fiscal Recovery Funds provide substantial flexibility for each jurisdiction to meet local needs—including support for households, small businesses, impacted industries, essential workers, and the communities hardest-hit by the crisis. These funds also deliver resources that recipients can invest in building, maintaining, or upgrading their water, sewer, and broadband infrastructure.

Starting today, eligible state, territorial, metropolitan city, county, and Tribal governments may request Coronavirus State and Local Fiscal Recovery Funds through the Treasury Submission Portal. Concurrent with this program launch, Treasury has published an Interim Final Rule that implements the provisions of this program.

FUNDING AMOUNTS

The American Rescue Plan provides a total of \$350 billion in Coronavirus State and Local Fiscal Recovery Funds to help eligible state, local, territorial, and Tribal governments meet their present needs and build the foundation for a strong recovery. Congress has allocated this funding to tens of thousands of jurisdictions. These allocations include:

| Type | Amount (\$ billions) |
|--|-------------------------|
| States & District of Columbia | \$195.3 |
| Counties | \$65.1 |
| Metropolitan Cites | \$45.6 |
| Tribal Governments | \$20.0 |
| Territories | \$4.5 |
| Non-Entitlement Units of Local Government | \$19.5 |

Treasury expects to distribute these funds directly to each state, territorial, metropolitan city, county, and Tribal government. Local governments that are classified as non-entitlement units will receive this funding through their applicable state government. Treasury expects to provide further guidance on distributions to non-entitlement units next week.

Local governments should expect to receive funds in two tranches, with 50% provided beginning in May 2021 and the balance delivered 12 months later. States that have experienced a net increase in the unemployment rate of more than 2 percentage points from February 2020 to the latest available data as of the date of certification will receive their full allocation of funds in a single payment; other states will receive funds in two equal tranches. Governments of U.S. territories will receive a single payment. Tribal governments will receive two payments, with the first payment available in May and the second payment, based on employment data, to be delivered in June 2021.

USES OF FUNDING

Coronavirus State and Local Fiscal Recovery Funds provide eligible state, local, territorial, and Tribal governments with a substantial infusion of resources to meet pandemic response needs and rebuild a stronger, more equitable economy as the country recovers. Within the categories of eligible uses, recipients have broad flexibility to decide how best to use this funding to meet the needs of their communities. Recipients may use Coronavirus State and Local Fiscal Recovery Funds to:

- **Support public health expenditures**, by funding COVID-19 mitigation efforts, medical expenses, behavioral healthcare, and certain public health and safety staff;
- **Address negative economic impacts caused by the public health emergency**, including economic harms to workers, households, small businesses, impacted industries, and the public sector;
- **Replace lost public sector revenue**, using this funding to provide government services to the extent of the reduction in revenue experienced due to the pandemic;
- **Provide premium pay for essential workers**, offering additional support to those who have borne and will bear the greatest health risks because of their service in critical infrastructure sectors; and,
- **Invest in water, sewer, and broadband infrastructure**, making necessary investments to improve access to clean drinking water, support vital wastewater and stormwater infrastructure, and to expand access to broadband internet.

Within these overall categories, Treasury’s Interim Final Rule provides guidelines and principles for determining the types of programs and services that this funding can support, together with examples of allowable uses that recipients may consider. As described below, Treasury has also designed these provisions to take into consideration the disproportionate impacts of the COVID-19 public health emergency on those hardest-hit by the pandemic.

1. Supporting the public health response

Mitigating the impact of COVID-19 continues to require an unprecedented public health response from state, local, territorial, and Tribal governments. Coronavirus State and Local Fiscal Recovery Funds provide resources to meet these needs through the provision of care for those impacted by the virus and through services that address disparities in public health that have been exacerbated by the pandemic. Recipients may use this funding to address a broad range of public health needs across COVID-19 mitigation, medical expenses, behavioral healthcare, and public health resources. Among other services, these funds can help support:

- **Services and programs to contain and mitigate the spread of COVID-19, including:**
 - ✓ Vaccination programs
 - ✓ Medical expenses
 - ✓ Testing
 - ✓ Contact tracing
 - ✓ Isolation or quarantine
 - ✓ PPE purchases
 - ✓ Support for vulnerable populations to access medical or public health services
 - ✓ Public health surveillance (e.g., monitoring for variants)
 - ✓ Enforcement of public health orders
 - ✓ Public communication efforts
 - ✓ Enhancement of healthcare capacity, including alternative care facilities
 - ✓ Support for prevention, mitigation, or other services in congregate living facilities and schools
 - ✓ Enhancement of public health data systems
 - ✓ Capital investments in public facilities to meet pandemic operational needs
 - ✓ Ventilation improvements in key settings like healthcare facilities

- **Services to address behavioral healthcare needs exacerbated by the pandemic, including:**
 - ✓ Mental health treatment
 - ✓ Substance misuse treatment
 - ✓ Other behavioral health services
 - ✓ Hotlines or warmlines
 - ✓ Crisis intervention
 - ✓ Services or outreach to promote access to health and social services
- **Payroll and covered benefits expenses** for public health, healthcare, human services, public safety and similar employees, to the extent that they work on the COVID-19 response. For public health and safety workers, recipients can use these funds to cover the full payroll and covered benefits costs for employees or operating units or divisions primarily dedicated to the COVID-19 response.

2. Addressing the negative economic impacts caused by the public health emergency

The COVID-19 public health emergency resulted in significant economic hardship for many Americans. As businesses closed, consumers stayed home, schools shifted to remote education, and travel declined precipitously, over 20 million jobs were lost between February and April 2020. Although many have since returned to work, as of April 2021, the economy remains more than 8 million jobs below its pre-pandemic peak, and more than 3 million workers have dropped out of the labor market altogether since February 2020.

To help alleviate the economic hardships caused by the pandemic, Coronavirus State and Local Fiscal Recovery Funds enable eligible state, local, territorial, and Tribal governments to provide a wide range of assistance to individuals and households, small businesses, and impacted industries, in addition to enabling governments to rehire public sector staff and rebuild capacity. Among these uses include:

- **Delivering assistance to workers and families**, including aid to unemployed workers and job training, as well as aid to households facing food, housing, or other financial insecurity. In addition, these funds can support survivor's benefits for family members of COVID-19 victims.
- **Supporting small businesses**, helping them to address financial challenges caused by the pandemic and to make investments in COVID-19 prevention and mitigation tactics, as well as to provide technical assistance. To achieve these goals, recipients may employ this funding to execute a broad array of loan, grant, in-kind assistance, and counseling programs to enable small businesses to rebound from the downturn.
- **Speeding the recovery of the tourism, travel, and hospitality sectors**, supporting industries that were particularly hard-hit by the COVID-19 emergency and are just now beginning to mend. Similarly impacted sectors within a local area are also eligible for support.
- **Rebuilding public sector capacity**, by rehiring public sector staff and replenishing unemployment insurance (UI) trust funds, in each case up to pre-pandemic levels. Recipients may also use this funding to build their internal capacity to successfully implement economic relief programs, with investments in data analysis, targeted outreach, technology infrastructure, and impact evaluations.

3. Serving the hardest-hit communities and families

While the pandemic has affected communities across the country, it has disproportionately impacted low-income families and communities of color and has exacerbated systemic health and economic inequities. Low-income and socially vulnerable communities have experienced the most severe health impacts. For example, counties with high poverty rates also have the highest rates of infections and deaths, with 223 deaths per 100,000 compared to the U.S. average of 175 deaths per 100,000.

Coronavirus State and Local Fiscal Recovery Funds allow for a broad range of uses to address the disproportionate public health and economic impacts of the crisis on the hardest-hit communities, populations, and households. Eligible services include:

- **Addressing health disparities and the social determinants of health**, through funding for community health workers, public benefits navigators, remediation of lead hazards, and community violence intervention programs;
- **Investments in housing and neighborhoods**, such as services to address individuals experiencing homelessness, affordable housing development, housing vouchers, and residential counseling and housing navigation assistance to facilitate moves to neighborhoods with high economic opportunity;
- **Addressing educational disparities** through new or expanded early learning services, providing additional resources to high-poverty school districts, and offering educational services like tutoring or afterschool programs as well as services to address social, emotional, and mental health needs; and,
- **Promoting healthy childhood environments**, including new or expanded high quality childcare, home visiting programs for families with young children, and enhanced services for child welfare-involved families and foster youth.

Governments may use Coronavirus State and Local Fiscal Recovery Funds to support these additional services if they are provided:

- within a Qualified Census Tract (a low-income area as designated by the Department of Housing and Urban Development);
- to families living in Qualified Census Tracts;
- by a Tribal government; or,
- to other populations, households, or geographic areas disproportionately impacted by the pandemic.

4. Replacing lost public sector revenue

State, local, territorial, and Tribal governments that are facing budget shortfalls may use Coronavirus State and Local Fiscal Recovery Funds to avoid cuts to government services. With these additional resources, recipients can continue to provide valuable public services and ensure that fiscal austerity measures do not hamper the broader economic recovery.

Many state, local, territorial, and Tribal governments have experienced significant budget shortfalls, which can yield a devastating impact on their respective communities. Faced with budget shortfalls and pandemic-related uncertainty, state and local governments cut staff in all 50 states. These budget shortfalls and staff cuts are particularly problematic at present, as these entities are on the front lines of battling the COVID-19 pandemic and helping citizens weather the economic downturn.

Recipients may use these funds to replace lost revenue. Treasury's Interim Final Rule establishes a methodology that each recipient can use to calculate its reduction in revenue. Specifically, recipients will compute the extent of their reduction in revenue by comparing their actual revenue to an alternative representing what could have been expected to occur in the absence of the pandemic. Analysis of this expected trend begins with the last full fiscal year prior to the public health emergency and projects forward at either (a) the recipient's average annual revenue growth over the three full fiscal years prior to the public health emergency or (b) 4.1%, the national average state and local revenue growth rate from 2015-18 (the latest available data).

For administrative convenience, Treasury's Interim Final Rule allows recipients to presume that any diminution in actual revenue relative to the expected trend is due to the COVID-19 public health emergency. Upon receiving Coronavirus State and Local Fiscal Recovery Funds, recipients may immediately calculate the reduction in revenue that occurred in 2020 and deploy funds to address any shortfall. Recipients will have the opportunity to re-calculate revenue loss at several points through the program, supporting those entities that experience a lagged impact of the crisis on revenues.

Importantly, once a shortfall in revenue is identified, recipients will have broad latitude to use this funding to support government services, up to this amount of lost revenue.

5. Providing premium pay for essential workers

Coronavirus State and Local Fiscal Recovery Funds provide resources for eligible state, local, territorial, and Tribal governments to recognize the heroic contributions of essential workers. Since the start of the public health emergency, essential workers have put their physical well-being at risk to meet the daily needs of their communities and to provide care for others.

Many of these essential workers have not received compensation for the heightened risks they have faced and continue to face. Recipients may use this funding to provide premium pay directly, or through grants to private employers, to a broad range of essential workers who must be physically present at their jobs including, among others:

- ✓ Staff at nursing homes, hospitals, and home-care settings
- ✓ Workers at farms, food production facilities, grocery stores, and restaurants
- ✓ Janitors and sanitation workers
- ✓ Public health and safety staff
- ✓ Truck drivers, transit staff, and warehouse workers
- ✓ Childcare workers, educators, and school staff
- ✓ Social service and human services staff

Treasury's Interim Final Rule emphasizes the need for recipients to prioritize premium pay for lower income workers. Premium pay that would increase a worker's total pay above 150% of the greater of the state or county average annual wage requires specific justification for how it responds to the needs of these workers.

In addition, employers are both permitted and encouraged to use Coronavirus State and Local Fiscal Recovery Funds to offer retrospective premium pay, recognizing that many essential workers have not yet received additional compensation for work performed. Staff working for third-party contractors in eligible sectors are also eligible for premium pay.

6. Investing in water and sewer infrastructure

Recipients may use Coronavirus State and Local Fiscal Recovery Funds to invest in necessary improvements to their water and sewer infrastructures, including projects that address the impacts of climate change.

Recipients may use this funding to invest in an array of drinking water infrastructure projects, such as building or upgrading facilities and transmission, distribution, and storage systems, including the replacement of lead service lines.

Recipients may also use this funding to invest in wastewater infrastructure projects, including constructing publicly-owned treatment infrastructure, managing and treating stormwater or subsurface drainage water, facilitating water reuse, and securing publicly-owned treatment works.

To help jurisdictions expedite their execution of these essential investments, Treasury's Interim Final Rule aligns types of eligible projects with the wide range of projects that can be supported by the Environmental Protection Agency's Clean Water State Revolving Fund and Drinking Water State Revolving Fund. Recipients retain substantial flexibility to identify those water and sewer infrastructure investments that are of the highest priority for their own communities.

Treasury's Interim Final Rule also encourages recipients to ensure that water, sewer, and broadband projects use strong labor standards, including project labor agreements and community benefits agreements that offer wages at or above the prevailing rate and include local hire provisions.

7. Investing in broadband infrastructure

The pandemic has underscored the importance of access to universal, high-speed, reliable, and affordable broadband coverage. Over the past year, millions of Americans relied on the internet to participate in remote school, healthcare, and work.

Yet, by at least one measure, 30 million Americans live in areas where there is no broadband service or where existing services do not deliver minimally acceptable speeds. For millions of other Americans, the high cost of broadband access may place it out of reach. The American Rescue Plan aims to help remedy these shortfalls, providing recipients with flexibility to use Coronavirus State and Local Fiscal Recovery Funds to invest in broadband infrastructure.

Recognizing the acute need in certain communities, Treasury's Interim Final Rule provides that investments in broadband be made in areas that are currently unserved or underserved—in other words, lacking a wireline connection that reliably delivers minimum speeds of 25 Mbps download and 3 Mbps upload. Recipients are also encouraged to prioritize projects that achieve last-mile connections to households and businesses.

Using these funds, recipients generally should build broadband infrastructure with modern technologies in mind, specifically those projects that deliver services offering reliable 100 Mbps download and 100

Mbps upload speeds, unless impracticable due to topography, geography, or financial cost. In addition, recipients are encouraged to pursue fiber optic investments.

In view of the wide disparities in broadband access, assistance to households to support internet access or digital literacy is an eligible use to respond to the public health and negative economic impacts of the pandemic, as detailed above.

8. Ineligible Uses

Coronavirus State and Local Fiscal Recovery Funds provide substantial resources to help eligible state, local, territorial, and Tribal governments manage the public health and economic consequences of COVID-19. Recipients have considerable flexibility to use these funds to address the diverse needs of their communities.

To ensure that these funds are used for their intended purposes, the American Rescue Plan Act also specifies two ineligible uses of funds:

- **States and territories may not use this funding to directly or indirectly offset a reduction in net tax revenue due to a change in law from March 3, 2021 through the last day of the fiscal year in which the funds provided have been spent.** The American Rescue Plan ensures that funds needed to provide vital services and support public employees, small businesses, and families struggling to make it through the pandemic are not used to fund reductions in net tax revenue. Treasury's Interim Final Rule implements this requirement. If a state or territory cuts taxes, they must demonstrate how they paid for the tax cuts from sources other than Coronavirus State Fiscal Recovery Funds—by enacting policies to raise other sources of revenue, by cutting spending, or through higher revenue due to economic growth. If the funds provided have been used to offset tax cuts, the amount used for this purpose must be paid back to the Treasury.
- **No recipient may use this funding to make a deposit to a pension fund.** Treasury's Interim Final Rule defines a "deposit" as an extraordinary contribution to a pension fund for the purpose of reducing an accrued, unfunded liability. While pension deposits are prohibited, recipients may use funds for routine payroll contributions for employees whose wages and salaries are an eligible use of funds.

Treasury's Interim Final Rule identifies several other ineligible uses, including funding debt service, legal settlements or judgments, and deposits to rainy day funds or financial reserves. Further, general infrastructure spending is not covered as an eligible use outside of water, sewer, and broadband investments or above the amount allocated under the revenue loss provision. While the program offers broad flexibility to recipients to address local conditions, these restrictions will help ensure that funds are used to augment existing activities and address pressing needs.

#6

RESOLUTION



July 7, 2021

Great lakes Contracting Solutions, LLC
Attn: Mr. Phillip Sakalian, Operations Manager
2300 Edinburgh
Waterford, MI 48328

Dear Mr. Sakalian,

The City of Pontiac and Great Lakes Contracting Solutions, LLC hereby mutually agree to extend the contract for "**Roadway Maintenance Program**" between the City of Pontiac and Great Lakes Contracting Solutions LLC originally dated June 26, 2018 for an effective date of July 1, 2018. **This agreed upon contract extension shall terminate at midnight June 30, 2022.**

This contract extension is created in accordance with Section VI Agreement within the contract documents.

This correspondence will serve as our contractual agreement to extend the above-mentioned contract based on the terms and conditions along with subsequent modifications, if any, as outlined in our agreement dated June 26, 2018.

Thank you for your continued service and dedication. We look forward to working with you and your team this contract year.

If you have any questions, or concerns, please feel free to contact me at 248.758.3617.

Sincerely,

CITY OF PONTIAC

By: _____ Date: _____

Al Cooley III, Deputy DPW Director, City of Pontiac

Agreed: _____ Date: _____

Phillip Sakalian, Operations Manager,
Great Lakes Contracting Solutions, LLC

I concur: _____ Date: _____

Deirdre Waterman, Mayor, City of Pontiac
DR/jc



CITY OF PONTIAC

OFFICIAL MEMORANDUM

Executive Branch

TO: Honorable Mayor, Council President and City Council Members

FROM: Allen H. Cooley III, Deputy Director of DPW

DATE: June 29, 2021

RE: **Resolution to approve one-year extension for Great Lakes Contracting Solutions, LLC for Roadway Maintenance Program.**

The Department of Public Works is requesting that the City Council approve a one-year extension of the contract for "**Roadway Maintenance Program**" between the City of Pontiac and Great Lakes Contracting Solutions LLC originally dated June 28, 2018. **This agreed upon contract extension shall terminate at midnight June 28, 2022.**

WHEREAS, Great Lakes Contracting Services performance over the last twelve months warrants a one-year extension of the initial agreement approved 6/28/2018.

**NOW, THEREFORE, BE
IT RESOLVED,**

The Pontiac City Council authorized the Mayor to extend the Roadway Maintenance Program contract with Great Lakes Contracting for 12 months beginning 6/28/2021 until 6/28/2022.

AHC

Attachments.



DPW CONTRACTOR SCORECARD

| Topic: | Score | Targeted Score |
|---|---------------|-----------------------|
| Attendance: | | |
| <ul style="list-style-type: none"> Employees meet scheduled work hours | 10 | 10 |
| Work Place Accidents: | | |
| <ul style="list-style-type: none"> # of Incidents | 0/10 | 10 |
| <ul style="list-style-type: none"> Cost of Incidents: | 0/10 | 10 |
| Facility Supervisor Satisfaction: | | |
| <ul style="list-style-type: none"> Direct Program | 9 | 10 |
| <ul style="list-style-type: none"> Deputy Director | 9 | 10 |
| <ul style="list-style-type: none"> DPW Director | 8 | 10 |
| Emergency Response Rating: | | |
| <ul style="list-style-type: none"> COVID Response | 8 | 10 |
| Overall Communication and Response: | | |
| <ul style="list-style-type: none"> Sr. Management | 8 | 10 |
| <ul style="list-style-type: none"> Foreman | 8 | 10 |
| Proposed Program Enhancements: | | |
| <ul style="list-style-type: none"> Discounts/cost savings initiatives | 8 | 10 |
| Other Considerations: | | |
| Supplies/Materials/Equipment | 9 | 10 |
| Total Score: | 97 | 110 |
| 0-84 | RED | Unsatisfactory |
| 85-90 | YELLOW | Satisfactory |
| 91-100 | GREEN | Goal Met |

CONTRACT FOR:
2018 Roadway Maintenance Program

- 1) Parties. The parties to this contract are the City of Pontiac, Michigan hereinafter referred to as the "City", and Great Lakes Contracting Solutions, LLC. hereinafter called the "Contractor".
- 2) Purpose. The purpose of this contract is for the City to engage the Contractor to Roadway Maintenance Services to the City (see Scope of Services below).
- 3) Scope of Services. The Contractor will provide all labor, materials, supplies, equipment and supervision to perform the Roadway Maintenance Services in the City. The Contractor is to perform all work in accordance with generally accepted standards and practices.
- 4) General Terms and Conditions. This contract is hereby made subject to the terms and conditions included in the Scope of Services (see Exhibit "A" below) and Additional Terms and Conditions (see Exhibit "B" below).
- 5) Consideration. As consideration for the performance of the services referenced in the Scope of Services (see Exhibits "A" & "B" below), the City agrees to compensate the Contractor as follows:

2018 ROADWAY MAINTENANCE PROGRAM

| No. | Items | Level 1 | Level 2 | Level 3 | Level 4 | Unit |
|-----|--|----------|----------|-----------|---------|------|
| 1 | Remove & Replace 4-inch Sidewalk (Residential) | | | | | |
| | Quantity | 1-500 | 501-1500 | 1501-5000 | 5001+ | SF |
| | Unit Price | \$ 14.00 | 12.50 | 10.00 | 9.00 | |
| 2 | Remove & Replace 6-inch Sidewalk (Residential and adjacent to driveways) | | | | | |
| | Quantity | 1-250 | 251-750 | 751-1500 | 1501+ | SF |
| | Unit Price | \$ 14.25 | 14.25 | 14.00 | 13.75 | |
| 3 | Remove & Replace 9-inch Sidewalk (Commercial/Industrial and adjacent to driveways) | | | | | |
| | Quantity | 1-250 | 251-750 | 751-1500 | 1501+ | SF |
| | Unit Price | \$ 19.50 | 16.25 | 15.00 | 14.00 | |
| 4 | Remove Sidewalk & Replace with ADA Ramp with Detectable Warning | | | | | |
| | Quantity | 1-400 | 401-800 | 801-3200 | 3201+ | SF |
| | Unit Price | 65.00 | 60.00 | 58.00 | 55.00 | |
| 5 | Remove & Replace Concrete Drive Approach, 6" (Residential) | | | | | |
| | Quantity | 1-500 | 501-1000 | 1001-2500 | 2501+ | SF |
| | Unit Price | 15.00 | 15.00 | 14.75 | 14.50 | |
| 6 | Remove and Replace Concrete Drive Approach, 9" (Commercial / Industrial) | | | | | |
| | Quantity | 1-500 | 501-1000 | 1001-5000 | 5000+ | SF |
| | Unit Price | 17.25 | 17.25 | 17.00 | 16.75 | |
| 7 | Restoration | | | | | |
| | Quantity | 1-500 | 501-2500 | 2501-7500 | 7501+ | SYD |
| | Unit Price | 8.50 | 8.25 | 8.00 | 7.50 | |
| 8 | Remove & Replace Concrete Curb & Gutter | | | | | |
| | Quantity | 1-50 | 51-250 | 251-1320 | 1321+ | LF |
| | Unit Price | 125.00 | 115.00 | 70.00 | 65.00 | |
| 9 | Remove HMA Surface | | | | | |
| | Quantity | 1-10 | 11-50 | 51-500 | 501+ | SYD |
| | Unit Price | 25.00 | 25.00 | 20.00 | 20.00 | |
| 10 | Cold Mill HMA Surface, 4" Thickness or Less | | | | | |
| | Quantity | 1-150 | 151-500 | 501-2000 | 2000+ | SYD |
| | Unit Price | 40.00 | 35.00 | 32.00 | 28.00 | |
| 11 | Install HMA, 1300 T, 20AAA Overlay | | | | | |
| | Quantity | 1-50 | 51-200 | 201-500 | 501+ | Ton |
| | Unit Price | 570.00 | 570.00 | 475.00 | 400.00 | |
| 12 | Install HMA, 1300 L, 20AAA Leveling / Base Course | | | | | |
| | Quantity | 1-50 | 51-200 | 201-500 | 501+ | Ton |
| | Unit Price | 570.00 | 570.00 | 475.00 | 400.00 | |
| 13 | HMA Hand Patching, 1300 T, 20AAA | | | | | |
| | Quantity | 1-10 | 11-25 | 26-50 | 50+ | Ton |
| | Unit Price | 600.00 | 600.00 | 575.00 | 525.00 | |
| 14 | Remove and Replace Concrete Pavement, 9 In., Non-Reinforced | | | | | |
| | Quantity | 1-10 | 11-50 | 51-500 | 501+ | SYD |
| | Unit Price | 180.00 | 180.00 | 170.00 | 160.00 | |

| No. | Items | Level 1 | Level 2 | Level 3 | Level 4 | Unit |
|-----|---|----------|---------|---------|----------|------|
| 15 | Epoxy Anchored Lane Ties | | | | | |
| | Quantity | 1-10 | 11-50 | 51-500 | 501+ | EA |
| | Unit Price | 15.00 | 12.50 | 9 | 9 | |
| 16 | Aggregate Base, 21AA, 6 In., Limestone | | | | | |
| | Quantity | 1-10 | 11-50 | 51-500 | 501+ | SYD |
| | Unit Price | 25.00 | 25.00 | 20.00 | 20.00 | |
| 17 | Aggregate Base, 21AA, 6 In., Crushed Concrete | | | | | |
| | Quantity | 1-10 | 11-50 | 51-500 | 501+ | SYD |
| | Unit Price | 20.00 | 20.00 | 15.00 | 12.00 | |
| 18 | Subgrade Undercutting, 21AA, Crushed Concrete | | | | | |
| | Quantity | 1-25 | 26-100 | 101-500 | 501+ | CYD |
| | Unit Price | 120.00 | 120.00 | 110.00 | 100.00 | |
| 19 | Items | Level 1 | Level 2 | Level 3 | Level 4 | |
| | Drainage Structure Repair-2'-4' Dia. | | | | | |
| | Quantity | 1-5 | 6-10 | 11-20 | 21+ | EA |
| 20 | Replace Existing Drainage Structure, 2' Dia. | | | | | |
| | Quantity | 1-5 | 6-10 | 11-20 | 21+ | EA |
| | Unit Price | 2,975.00 | 2850.00 | 2675.00 | 2,500.00 | |
| 21 | Replace Existing Drainage Structure, 4' Dia. | | | | | |
| | Quantity | 1-5 | 6-10 | 11-20 | 21+ | EA |
| | Unit Price | 4,500.00 | 4300.00 | 4200.00 | 4,000.00 | |
| 22 | Replace Existing Drainage Structure, 4' Dia., 8'-15' Deep | | | | | |
| | Quantity | 1-5 | 6-10 | 11-20 | 21+ | FT |
| | Unit Price | 500.00 | 500.00 | 450.00 | 400.00 | |
| 23 | Drainage Structure Cover Adjustment (raise/lower), Case 1 | | | | | |
| | Quantity | 1-5 | 6-10 | 11-20 | 21+ | EA |
| | Unit Price | 875.00 | 850.00 | 825.00 | 800.00 | |
| 24 | Drainage Structure Cover Adjustment (raise/lower), Case 2 | | | | | |
| | Quantity | 1-5 | 6-10 | 11-20 | 21+ | EA |
| | Unit Price | 775.00 | 750.00 | 725.00 | 700.00 | |
| 25 | Storm Sewer Replacement-12-inch Diameter RCP | | | | | |
| | Quantity | 1-50 | 51-150 | 151-500 | 500+ | LF |
| | Unit Price | 220.00 | 200.00 | 175.00 | 150.00 | |
| 26 | Storm Sewer Replacement-18-inch Diameter RCP | | | | | |
| | Quantity | 1-50 | 51-150 | 151-500 | 500+ | LF |
| | Unit Price | 250.00 | 245.00 | 240.00 | 230.00 | JW |
| 27 | Storm Sewer Replacement-21-inch Diameter RCP | | | | | |
| | Quantity | 1-50 | 51-150 | 151-500 | 500+ | LF |
| | Unit Price | 310.00 | 305.00 | 300.00 | 290.00 | |
| 28 | Storm Sewer Replacement-24-inch Diameter RCP | | | | | |
| | Quantity | 1-50 | 51-150 | 151-500 | 500+ | LF |
| | Unit Price | 350.00 | 340.00 | 330.00 | 300.00 | JW |

- 6) Period of Performance. Services to begin on July 9, 2018. The contract expires June 30, 2020 with the option for extension of the contract for year three. All services shall be performed according to the Agreement, as well as the submitted bid. The City has the right to break the agreement with 30 days' notice.
- 7) Method of Payment. Contractor will be paid 30 days after submission of a valid invoice.
- 8) Applicable Law. This contract shall be governed by and construed in accordance with the laws of the City of Pontiac, State of Michigan and applicable federal laws.
- 9) Compliance with Laws. The Contractor understands that the City is an equal opportunity employer and, therefore, maintains a policy which prohibits unlawful discrimination based on race, color, creed, sex, age, national origin, physical handicap, disability, genetic information, or any other consideration made unlawful by federal, state, or local laws. All such discrimination is unlawful and the Contractor agrees during the term of the agreement that the Contractor will strictly adhere to this policy in its employment practices and provision of services. The Contractor shall comply with, and all activities under this agreement shall be subject to, all applicable federal, State of Michigan, and City of Pontiac laws and regulations, as now existing and as may be amended or modified.

The Contractor is responsible for instructing and training their employees in appropriate safety measures. Employees will be responsible for maintaining a safe work environment while completing their tasks.

- a) The Contractor shall comply with the Michigan Right to Know Law (Amendments to Act 154), which requires that all employers within the State comply with federal Hazard Communications Standards (C.F.R. 1910.1200) and certain additional guidelines as of February 25, 1987. These Standards specify that employers develop a written hazard communication program, which is to be made available for workers or their designated representatives.
 - b) The Contractor will comply with all federal, state and local regulations, including but not limited to all applicable OSHA/MIOSHA requirements and the Americans with Disabilities Act
 - c) The Contractor is responsible for all applicable state and federal social security benefits and unemployment taxes and agrees to indemnify and protect the City against such liability.
- 10) Requirements contract. During the period of the contract, the Contractor shall provide all the services described in the contract. The Contractor understands and agrees that this is a requirements contract and that the City shall have no obligation to the Contractor if no services are required.

EXHIBIT "A"

SCOPE OF SERVICES

The Contractor shall perform construction services for roadway maintenance in the City of Pontiac with related work for the 2018 Roadway Maintenance Program.

SCOPE OF WORK

Contractor will provide all labor, equipment, and materials for the requested work under the different levels of contract within the following "Section IV. Request" and Scope of Work listed in the attached "2018 ROADWAY MAINTENANCE PROGRAM BID" in Appendix A.

All workmanship and materials shall be in accordance with the Michigan Department of Transportation (MDOT) 2012 Standard Specifications for Construction, Standard Plans, Special Details, Supplemental Specifications, Special Provisions, City of Pontiac Standards and Details for Construction. In addition, all workmanship and materials for soil erosion, sanitary sewer covers and adjustments, water services, appurtenances, fire hydrant, gate valve, and gate well covers and adjustments, if required, shall be in accordance with the Oakland County Water Resource Commissioners Standards, Details, and Specifications.

All streets shall remain open to through traffic for the duration of construction, unless approved by the City of Pontiac. The Contractor shall provide local traffic access to residents along streets within the project.

Provide material certification, and Quality Control (QC) and Quality Assurance (QA) testing in accordance with the MDOT specifications.

The Contractor shall cooperate and coordinate construction activities with the owners of utilities as stated in Section 104.08 of the 2012 Michigan Department of Transportation (MDOT) Standard Specifications for Construction. In addition, for the protection of underground utilities, the Contractor shall follow the requirements in Section 107.12 of the 2012 MDOT Standard Specifications for Construction, and the Oakland County Water Resources Commissioner and the technical specifications included in these bid documents. Contractor delay claims, resulting from a utility, will be determined based upon Section 109.05E of the 2012 MDOT Standard Specifications for Construction.

All change orders shall be authorized using addendums to the Contract.

The Contractor must submit Emergency (24 Hours) phone numbers on the company letterhead when submitting contracts.

Additional documents included in the Scope of Work: (See original bid proposal packet)

Attachment A:
MDOT Frequently Used Special Provisions

For a copy of the submitted bid proposal please reference Exhibit "C".

EXHIBIT "B"**ADDITIONAL TERMS AND CONDITIONS**

- 1) Attorneys' fees and expenses. Subject to other terms and conditions of this contract, in the event the Contractor defaults in any obligation under this contract, the Contractor shall pay to the City all costs and expenses (including, without limitation, investigative fees, court costs, and attorneys' fees) incurred by the City in enforcing this contract or otherwise reasonably related thereto. Contractor agrees that under no circumstances shall the City be obligated to pay any attorneys' fees or costs of legal action to the Contractor.
- 2) Authority to contract. The Contractor warrants: (a) that it is a validly organized business with valid authority to enter into this contract; (b) that it is qualified to do business and in good standing in the State of Michigan; (c) that entry into and performance under this contract is not restricted or prohibited by any loan, security, financing, contractual, or other contract of any kind; and, (d) notwithstanding any other provision of this contract to the contrary, that there are no existing legal proceedings or prospective legal proceedings, either voluntary or otherwise, which may adversely affect its ability to perform its obligations under this contract.
- 3) Confidential information. Disclosure of any confidential information by the Contractor or its subcontractor without the express written approval of the City shall result in the immediate termination of this contract.
- 4) Confidentiality. Notwithstanding any provision to the contrary contained herein, it is recognized that the City of Pontiac is a public city of the State of Michigan and is subject to the laws regarding confidentiality. If a public records request is made for any information provided to the City pursuant to the contract, the City shall promptly notify the disclosing party of such request and will respond to the request only in accordance with the procedures and limitations set forth in applicable law. The disclosing party shall promptly institute appropriate legal proceedings to protect its information. No party to the contract shall be liable to the other party for disclosures of information required by court order or required by law.
- 5) Contractor personnel. The City shall, throughout the life of the contract, have the right of reasonable rejection and approval of staff or subcontractors assigned to the work by the Contractor. If the City reasonably rejects staff or subcontractors, the Contractor shall provide replacement staff or subcontractors satisfactory to the City in a timely manner and at no additional cost to the City. The day-to-day supervision and control of the Contractor's employees and subcontractors is the sole responsibility of the Contractor. Contractor personnel are subject to background checks by the Oakland County Sheriff Department and shall comply with all requirements as outlined in the Request for Quote.
- 6) Insurance. The Contractor shall not commence work under this contract until it has obtained the required insurance under this paragraph. All coverage shall be with insurance companies

licensed and permitted to do business in the State of Michigan. All coverage shall be with carriers acceptable to the City of Pontiac:

- a) Workers' Compensation Insurance. The Contractor shall procure and maintain during the life of this contract, Workers' Insurance, including Employers Liability Coverage, in accordance with all applicable statutes of the State of Michigan with a minimum limit of \$100,000 each accident for any employee.
- b) Commercial General Liability Insurance. The Contractor shall procure and maintain during the life of this contract, Commercial General Liability Insurance on an "Occurrence Basis" with limits of liability not less than \$2,000,000 per occurrence and aggregate for Personal Injury, Bodily Injury and Property Damage, coverage shall include the following extensions: (A) Contractual Liability; (B) Products and Completed Operations; (C) Independent Contractors Coverage; (D) Broad Form General Liability Extensions or equivalent; (E) Deletion of all Explosion, Collapse and Underground (XCU) Exclusions, if applicable; (F) Per project aggregate.
- c) Motor Vehicle Liability. The Contractor shall procure and maintain during the life of this contract Motor Vehicle Liability Insurance, including Michigan No-Fault Coverage, with limits of liability of not less than \$2,000,000 per occurrence combined single limit Bodily Injury and Property Damage. Coverage shall include all owned vehicles, all non-owned vehicles, and all hired vehicles.
- d) Professional Liability Insurance. The Contractor shall procure and maintain during the life of this contract, Professional Liability insurance in an amount not less than \$1,000,000 per occurrence and \$1,000,000 aggregate. If this policy is claims made form, the contractor shall be required to keep the policy in force, or purchase "tail" coverage, for a minimum of 3 years after the termination of this contract.
- e) Additional Insured: Commercial General Liability and Motor Vehicle Liability Insurance, as described above, shall include an endorsement stating the following shall be **Additionally Insured**: The City of Pontiac, Oakland County Water Resources Commissioner, all elected and appointed officials, all employees and volunteers, all boards, commissions, and/or authorities and board members, including employees and volunteers. It is understood and agreed by naming The City of Pontiac as additional insured, coverage afforded is considered to be primary and any other insurance The City of Pontiac may have in effect shall be considered secondary and/or excess.
- f) Cancellation Notice: All policies, as described above, shall include an endorsement stating that is it understood and agreed Thirty (30) days, Ten (10) days for non-payment of premium, Advance Written Notice of Cancellation, Non-Renewal, Reduction, and/or Material Change shall be sent to: City Administrator for the City of Pontiac

- g) Proof of Insurance Coverage: The Contractor shall provide The City of Pontiac at the time that the contracts are returned by him/her for execution, a Certificate of Insurance as well as the required endorsements. In lieu of required endorsements, if applicable, a copy of the policy sections where coverage is provided for additional insured and cancellation notice would be acceptable. Copies or certified copies of all policies mentioned above shall be furnished, if so requested.
 - h) Expiration of Policies: If any of the above coverage expires during term of this contract, the Contractor shall deliver renewal certificates and/or policies to the City of Pontiac at least ten (10) days prior to the expiration date.
 - i) Insurance companies, named insureds and policy forms shall be subject to approval by Pontiac's Department of Public Works. Such approval shall not be unreasonably withheld. Insurance policies shall not contain endorsements or a policy condition, that reduces coverage provided to the City of Pontiac. Contractor shall be responsible to the City of Pontiac or insurance companies insuring the City of Pontiac for all costs resulting from both financially unsound insurance companies selected by Contractor and their inadequate insurance coverage. Contractor shall furnish the Pontiac Finance Department with satisfactory certificates of insurance or a certified copy of the policy, if requested by the Finance Department.
 - j) No payments will be made to the Contractor until the current certificates of insurance have been received and approved by the Finance Department. If the insurance as evidenced by the certificates furnished by the Contractor expires or is canceled during the term of the contract, services and related payments will be suspended. Contractor shall furnish the Finance Department with certification of insurance evidencing such coverage and endorsements at least ten (10) working days prior to commencement of services under this contract. Certificates shall be addressed to the Pontiac Finance Department, and shall provide for 30 day written notice to the Certificate holder of cancellation of coverage except as provided in Section 6(f) of this Agreement.
- 7) Ineligibility and suspension. The Contractor certifies to the best of its knowledge and belief, that it: (a) is not presently ineligible, suspended, proposed for ineligibility, declared ineligible, or voluntarily excluded from covered transaction by any federal department or the City or any political subdivision of the City or the State of Michigan; (b) has not, within a three year period preceding this proposal, been convicted of or had civil judgment rendered against it for commission of fraud or a criminal offense in connection with obtaining, attempting to obtain, or performing a public (federal, state, or local) transaction or contract under a public transaction; (c) has not, within a three year period preceding this proposal, been convicted of or had civil judgment rendered against it for a violation of Federal or State antitrust statutes or commission of embezzlement, theft, forgery, bribery, falsification or destruction of records, making false statements, or receiving stolen property; (d) is not presently indicted

for or otherwise criminally or civilly charged by a governmental entity (federal, state or local) with commission of any of these offenses enumerated in paragraphs (b) and (c) of this certification; and, (e) has not, within a three year period preceding this proposal, had one or more public transactions (federal, state, or local) terminated for cause or default.

- 8) Disclosure of confidential information. In the event that either party to this contract receives notice that a third party requests divulgence of confidential or otherwise protected information and/or has served upon it subpoena or other validly issued administrative or judicial process ordering divulgence of confidential or otherwise protected information that party shall promptly inform the other party and thereafter respond in conformity with such subpoena to the extent mandated by law. This section shall survive the termination or completion of this contract.
- 9) Exceptions to confidential information. The Contractor and the City shall not be obligated to treat as confidential and proprietary any information disclosed by the other party ("disclosing party") which: (a) is rightfully known to the recipient prior to negotiations leading to this contract, other than information obtained in confidence under prior engagements; (b) is generally known or easily ascertainable by nonparties of ordinary skill in the business of the customer; (c) is released by the disclosing party to any other person, firm, or entity (including governmental agencies or bureaus) without restriction; (d) is independently developed by the recipient without any reliance on confidential information; (e) is or later becomes part of the public domain or may be lawfully obtained by the City or the Contractor from any nonparty; or, (f) is disclosed with the disclosing party's prior written consent.
- 10) Default. If the Contractor:
 - a) Fails to supply complete labor and supervision in sufficient time and quantity to meet the City's progress schedule, as it may be modified;
 - b) Causes stoppage or delay of, or interference with, the project;
 - c) Fails to promptly pay its employees for work on the project;
 - d) Fails to pay worker's compensation or other employee benefits, withholding or any other taxes;
 - e) Fails to comply with the safety provisions of the Contract or with any safety order, regulation or requirement of any governing authority having jurisdiction over this project;
 - f) Makes unauthorized changes in supervisory personnel;
 - g) Fails in performance or observance of any of the provisions of the contract;

- h) Files a voluntary petition in bankruptcy or is adjudicated insolvent;
- i) Obtains an order for relief under Section 301 of the Bankruptcy Code;
- j) Files any petition or fails to contest any petition filed seeking any reorganization or similar relief under any laws relating to bankruptcy, insolvency or other relief of debtors;
- k) Or seeks or consents to or is acquiescent in the appointment of a trustee, receiver or liquidator of any of its assets or property;
- l) Makes an assignment for the benefit of creditors; or
- m) Makes an admission, in writing, of its inability to pay its debts as they became due;

Then City, after giving Contractor written or oral (subsequently confirmed in writing) notice of such default and forty-eight (48) hours within which to cure such default, shall have the right to exercise any one or more of the following remedies:

- a) Require that Contractor utilize, at its own expense, additional labor, overtime labor (including Saturday and Sunday work) and additional shifts as necessary to overcome the consequences of any delay attributable to Contractor's default.
 - b) Remedy the default by whatever means City may deem necessary or appropriate, including, but not limited to, correcting, furnishing, performing or otherwise completing the work, or any part thereof, by itself or through others (utilizing where appropriate any materials and equipment previously purchased for that purpose by Contractor) and deducting the cost thereof from any monies due or to become due to Contractor hereunder;
 - i) After giving Contractor an additional forty-eight (48) hours written (or oral, subsequently confirmed in writing) notice, terminate this Contract, without thereby waiving or releasing any rights or remedies against Contractor or its sureties, and, by itself or through others, take possession of the work, and all materials, relating to the work, for the purposes of costs and other damages under the contract and for the breach thereof; and
 - ii) Recover all reasonable attorneys' fees suffered or incurred by City by reason of, or as a result of, Contractor's default.
- 11) Failure to enforce. Failure by the City at any time to enforce the provisions of the contract shall not be construed as a waiver of any such provisions. Such failure to enforce shall not affect the validity of the contract or any part thereof or the right of the City to enforce any provision at any time in accordance with its terms.

- 12) Final payment. Upon satisfactory completion of the work performed under this contract, as a condition before final payment under this contract, or as a termination settlement under this contract, the Contractor shall execute and deliver to the City a release of all claims against the City arising under, or by virtue of, the contract, except claims which are specifically exempted by the Contractor to be set forth therein. Unless otherwise provided in this contract, by state law, or otherwise expressly agreed to by the parties in this contract, final payment under the contract or settlement upon termination of this contract shall not constitute waiver of the City's claims against the Contractor under this contract.
- 13) Force majeure. Each party shall be excused from performance for any period and to the extent that it is prevented from performing any obligation or service, in whole or in part, as a result of causes beyond the reasonable control and without the fault or negligence of such party and/or its subcontractors. Such acts shall include without limitation acts of God, strikes, lockouts, riots, and acts of war, epidemics, governmental regulations superimposed after the fact, fire, earthquakes, floods, or other natural disasters (the "force majeure events"). When such a cause arises, the Contractor shall notify the City immediately in writing of the cause of its inability to perform, how it affects its performance, and the anticipated duration of the inability to perform. Delays in delivery or in meeting completion dates due to force majeure events shall automatically extend such dates for a period equal to the duration of the delay caused by such events, unless the City determines it to be in its best interest to terminate the contract.
- 14) Indemnification. To the fullest extent allowed by law, the Contractor shall indemnify, defend, save and hold harmless, protect, and exonerate the City, its commissioners, board members, officers, employees, agents, representatives, and the State of Michigan from and against all claims, demands, liabilities, suits, actions, damages, losses, and costs of every kind and nature whatsoever including, without limitation, court costs, investigative fees and expenses, and attorneys' fees, arising out of or caused by the Contractor and/or its partners, principals, agents, employees and/or subcontractors in the performance of or failure to perform this contract. In the City's sole discretion, the Contractor may be allowed to control the defense of any such claim, suit, etc. In the event the Contractor defends said claim, suit, etc., the Contractor shall use legal counsel acceptable to the City. The Contractor shall be solely responsible for all costs and/or expenses associated with such defense, and the City shall be entitled to participate in said defense. The Contractor shall not settle any claim, suit, etc., without the City's concurrence, which the City shall not unreasonably withhold.
- 15) Independent contractor status. The Contractor shall, at all times, be regarded as and shall be legally considered an independent contractor and shall at no time act as an agent for the City. Nothing contained herein shall be deemed or construed by the City, the Contractor, or any third party as creating the relationship of principal and agent, master and servant, partners, joint ventures, employer and employee, or any similar such relationship between the City and the Contractor. Neither the method of computation of fees or other charges, nor any other provision contained herein, nor any acts of the City or the Contractor

hereunder creates, or shall be deemed to create, a relationship other than the independent relationship of the City and the Contractor. The Contractor's personnel shall not be deemed in any way, directly or indirectly, expressly or by implication, to be employees of the City or the State of Michigan. Neither the Contractor nor its employees shall, under any circumstances be considered servants, agents, or employees of the City and the City shall be at no time legally responsible for any negligence or other wrongdoing by the Contractor, its servants, agents, or employees. The City shall not withhold from the contract payments to the Contractor any federal or state unemployment taxes, federal or state income taxes, social security tax, or any other amounts for benefits to the Contractor. Further, the City shall not provide to the Contractor any insurance coverage or other benefits, including worker's compensation, normally provided by the City for its employees.

- 16) No limitation of liability. Nothing in this contract shall be interpreted as excluding or limiting any tort liability of the Contractor for harm caused by the intentional or reckless conduct of the Contractor or for damages incurred through the negligent performance of duties by the Contractor or the delivery of products that are defective due to negligent construction.
- 17) Notices. All notices required or permitted to be given under this contract shall be in writing and personally delivered or sent by certified United States mail, postage prepaid, return receipt requested, to the Pontiac City Clerk's Office to whom the notice should be given at the address set forth below. Notice shall be deemed given when actually received or when refused. The parties agree to promptly notify each other in writing of any change of address.

For the Contractor: Great Lakes Contracting Solutions, LLC.
2300 Edinburgh
Waterford, MI 48327

For the City: City of Pontiac
47450 Woodward Avenue
Pontiac, MI 48342

- 18) Oral statements. No oral statement of any person shall modify or otherwise affect the terms, conditions, or specifications stated in this contract. All modifications to the contract shall be made in writing by the City and agreed to by the Contractor.
- 19) Ownership of documents and work papers. The City shall own all documents, files, reports, work papers and working documentation, electronic or otherwise, created in connection with the project which is the subject of this contract, except for the Contractor's internal administrative and quality assurance files and internal project correspondence. The Contractor shall deliver such documents and work papers to the City upon termination or completion of the contract. The foregoing notwithstanding, the Contractor shall be entitled to retain a set of such work papers for its files. The Contractor shall be entitled to use such

work papers only after receiving written permission from the City and subject to any copyright protections.

- 20) Priority. The contract consists of this contract with exhibits. Any ambiguities, conflicts or questions of interpretation of this contract shall be resolved by first, reference to this contract with exhibits and, if still unresolved, by reference to the bid. Omission of any term or obligation from this contract shall not be deemed an omission from this contract if such term or obligation is provided for elsewhere in this contract.
- 21) Quality control. The Contractor shall institute and maintain throughout the contract period a properly documented quality control program designed to ensure that the services are provided at all times and in all respects in accordance with the contract. The program shall include providing daily supervision and conducting frequent inspections of the Contractor's staff and ensuring that accurate records are maintained describing the disposition of all complaints. The records so created shall be open to inspection by the City.
- 22) Record retention and access to records. Provided the Contractor is given reasonable advance written notice and such inspection is made during normal business hours of the Contractor, the City or any duly authorized representatives shall have unimpeded, prompt access to any of the Contractor's books, documents, papers, and/or records which are maintained or produced as a result of the project for the purpose of making audits, examinations, excerpts, and transcriptions. All records related to this contract shall be retained by the Contractor for three years after final payment is made under this contract and all pending matters are closed; however, if any audit, litigation or other action arising out of or related in any way to this project is commenced before the end of the three year period, the records shall be retained for one year after all issues arising out of the action are finally resolved or until the end of the three year period, whichever is later.
- 23) Recovery of money. Whenever, under the contract, any sum of money shall be recoverable from or payable by the Contractor to the City, the same amount may be deducted from any sum due to the Contractor under the contract or under any other contract between the Contractor and the City. The rights of the City are in addition and without prejudice to any other right the City may have to claim the amount of any loss or damage suffered by the City on account of the acts or omissions of the Contractor.
- 24) Right to audit. The Contractor shall maintain such financial records and other records as may be prescribed by the City or by applicable federal and state laws, rules, and regulations. The Contractor shall retain these records for a period of three years after final payment, or until they are audited by the City, whichever event occurs first. These records shall be made available during the term of the contract and the subsequent three-year period for examination, transcription, and audit by the Michigan Office of the State Auditor, its designees, or other authorized bodies.

- 25) Right to inspect facility. The City may, at reasonable times, inspect the place of business of the Contractor or any subcontractor, which is related to the performance of any contract awarded by the City.
- 26) Severability. If any part of this contract is declared to be invalid or unenforceable, such invalidity or unenforceability shall not affect any other provision of the contract that can be given effect without the invalid or unenforceable provision, and to this end the provisions hereof are severable. In such event, the parties shall amend the contract as necessary to reflect the original intent of the parties and to bring any invalid or unenforceable provisions in compliance with applicable law.
- 27) City property. The Contractor will be responsible for the proper custody and care of any City-owned property furnished for the Contractor's use in connection with the performance of this contract. The Contractor will reimburse the City for any loss or damage, normal wear and tear excepted.
- 28) Termination for convenience clause.
- a) The City reserves the absolute right to terminate the contract in whole or in part, for the convenience of the City at its sole discretion on thirty (30) days written notice to the Contractor. The City has the right, upon its sole discretion only, to terminate the contract with cause by giving notice to the Contractor of such termination, specifying the effective date thereof, at least fourteen (14) days before the effective date of such termination, and the Contract shall terminate in all respects as if such date were the date originally given for the expiration of the Contract.
 - b) The Contractor shall be liable to the City for damages sustained by the City by virtue of any breach of the Contract by the Contractor, and any costs the City might incur enforcing or attempting to enforce the Contract, and the City may pursue legal remedies in the collection of fees to compensate for the damages sustained by the City.
 - c) Contractor's Obligations. The Contractor shall incur no further obligations in connection with the terminated work and on the date set in the notice of termination the Contractor will stop work to the extent specified. The Contractor shall also terminate outstanding orders and subcontracts as they relate to the terminated work. The Contractor shall settle the liabilities and claims arising out of the termination of subcontracts and orders connected with the terminated work. The City may direct the Contractor to assign the Contractor's right, title, and interest under terminated orders or subcontracts to the State of Michigan. The Contractor shall still complete the work not terminated by the notice of termination and may incur obligations as are necessary to do so.

29) Termination for default clause.

- a) Default. If the Contractor refuses or fails to perform any of the provisions of this contract with such diligence as will ensure its completion within the time specified in this contract or any extension thereof, or otherwise fails to timely satisfy the contract provisions, or commits any other substantial breach of this contract, the City may notify the Contractor in writing of the delay or nonperformance and if not cured in ten days or any longer time specified in writing by the City, the City may terminate the Contractor's right to proceed with the contract or such part of the contract as to which there has been delay or a failure to properly perform. In the event of termination in whole or in part, the City may procure similar supplies or services in a manner and upon terms deemed appropriate by the City. The Contractor shall continue performance of the contract to the extent it is not terminated and shall be liable for excess costs incurred in procuring similar goods or services.
- b) Contractor's Duties. Notwithstanding termination of the contract and subject to any directions from the City, the Contractor shall take timely, reasonable, and necessary action to protect and preserve property in the possession of the Contractor in which the City has an interest.
- c) Compensation. Payment for completed services delivered and accepted by the City shall be at the contract price. The City may withhold from amounts due the Contractor such sums as the City deems to be necessary to protect the City against loss because of outstanding liens or claims of former lien holders and to reimburse the City for the excess costs incurred in procuring similar goods and services.
- d) Excuse for Nonperformance or Delayed Performance. Except with respect to defaults of subcontractors, the Contractor shall not be in default by reason of any failure in performance of this contract in accordance with its terms (including any failure by the Contractor to make progress in the prosecution of the work hereunder which endangers such performance) if the Contractor has notified the City within 15 days after the cause of the delay and the failure arises out of causes such as: acts of God; acts of the public enemy; acts of the State of Michigan and any other governmental entity in its sovereign or contractual capacity; fires; floods; epidemics; quarantine restrictions; strikes or other labor disputes; freight embargoes; or unusually severe weather. If the failure to perform caused by the failure of a subcontractor to perform or to make progress, and if such failure arises out of causes similar to those set forth above, the Contractor shall not be deemed to be in default, unless the services to be furnished by the subcontractor were reasonably obtainable from other sources in sufficient time to permit the Contractor to meet the contract requirements. Upon request of the Contractor, the City shall ascertain the facts and extent of such failure, and, if such officer determines that any failure to perform was occasioned by any one or more of the excusable causes, and that, but for the excusable cause, the Contractor's progress and performance would have met the terms of the contract, the delivery schedule shall be revised accordingly, subject to the

rights of the City under the clause entitled "Termination for Convenience." (As used in this paragraph, the term "subcontractor" means subcontractor at any tier).

- e) Erroneous Termination for Default. If, after notice of termination of the Contractor's right to proceed under the provisions of this clause, it is determined for any reason that the contract was not in default under the provisions of this clause, or that the delay was excusable under the provisions of Paragraph (d) (Excuse for Nonperformance or Delayed Performance) of this clause, the rights and obligations of the parties shall, if the contract contains a clause providing for termination for convenience by the City, be the same as if the notice of termination had been issued pursuant to such clause.
 - f) Additional Rights and Remedies. The rights and remedies provided in this clause are in addition to any other rights and remedies provided by law or under this contract.
- 30) Termination upon bankruptcy. This contract may be terminated in whole or in part by the City upon written notice to the Contractor, if the Contractor should become the subject of bankruptcy or receivership proceedings, whether voluntary or involuntary, or upon the execution by the Contractor of an assignment for the benefit of its creditors. In the event of such termination, the Contractor shall be entitled to recover just and equitable compensation for satisfactory work performed under this contract, but in no case shall said compensation exceed the total contract price.
- 31) Third party action notification. The Contractor shall give the City prompt notice in writing of any action or suit filed, and prompt notice of any claim made against the Contractor by any entity that may result in litigation related in any way to this contract.
- 32) Unsatisfactory work. If, at any time during the contract term, the service performed or work done by the Contractor is considered by the City to create a condition that threatens the health, safety, or welfare of the citizens and/or employees of the City of Pontiac, the Contractor shall, on being notified by the City, immediately correct such deficient service or work. In the event the Contractor fails, after notice, to correct the deficient service or work immediately, the City shall have the right to order the correction of the deficiency by separate contract or with its own resources at the expense of the Contractor.
- 33) Waiver. No delay or omission by either party to this contract in exercising any right, power, or remedy hereunder or otherwise afforded by contract, at law, or in equity shall constitute an acquiescence therein, impair any other right, power or remedy hereunder or otherwise afforded by any means, or operate as a waiver of such right, power, or remedy. No waiver by either party to this contract shall be valid unless set forth in writing by the party making said waiver. No waiver of or modification to any term or condition of this contract will void, waive, or change any other term or condition. No waiver by one party to this contract of a default by the other party will imply, be construed as, or require waiver of future or other defaults.

34) Taxes and Contributions. The Contractor hereby accepts and assumes exclusive liability for and shall indemnify, protect and save harmless the City from and against the payment of:

- a) Contractor agrees to contact the City of Pontiac Income Tax Division, Audit and Compliance Section, 47450 Woodward, Pontiac, Michigan 48342, to establish reporting and withholding obligations under the City of Pontiac Income Tax Ordinance. Contractors will require the same of all subcontractors employed to perform any work in the City of Pontiac.

Web page URL: http://www.pontiac.mi.us/departments/income_tax/index.php

Tax forms URL: http://www.pontiac.mi.us/departments/income_tax/tax_forms.php

- b) All contributions, taxes or premiums (including interest and penalties thereon) which may be payable under the Unemployment Insurance Law of any State, the Federal Social Security Act, Federal, State, County and/or Municipal Tax Withholding Act, Federal, State, County and/or Municipal Tax Withholding Laws, or any other law, measured upon the payroll of or required to be withheld from employees by whomsoever employed or engaged in the work to be performed and furnished under this contract.
- c) All sales, use, personal property and other taxes (including interest and penalties thereon) required by any Federal, State, County, Municipal or other law to be paid or collected by the Contractor or any of its vendors or any other person or persons acting for, through or under it or any of them, by reason of the performance of this work or the acquisition, furnishing, or use of any materials, equipment, supplies, labor, services or other items for or in connection with the work.
- d) All pension, welfare, vacation, annuity and other union benefit contributions payable, under or in connection with respect, to all persons; by whomsoever employed or engaged in the work to be performed and furnished under this Contract.

2018 ROADWAY MAINTENANCE PROGRAM BID

47450 Woodward Avenue, Pontiac, MI 48342

Office: 248-758-3120 ~ fax: 248-758-3197

> 2018 ROADWAY MAINTENANCE PROGRAM BID <

Bidding Contractor: GREAT LAKES CONTRACTING
 Company Name: SOLUTIONS, LLC
 Representative: Tom Wall
 Address: 2300 Edinburgh City: Waterford Zip: 48320
 Office #: 313-962-0400 Fax #: 313-962-0404
 Cell#: 248-838-8699 Email: tom@greatlakescont.com
 License#: 801536634

Job Duties Sheet / Scope of Work

Contractor will provide all labor & material for the following service work:

2018 ROADWAY MAINTENANCE PROGRAM

- Perform all road work in accordance with the Michigan Department of Transportation (MDOT) 2012 Standard Specifications for Construction, Standard Plans, Special Details, Supplemental Specifications, Special Provisions, City of Pontiac Standards and Details for Construction, MMUTCD, requirements listed in this "Request to Submit Bids".
- Provide material certification, and Quality Control (QC) and Quality Assurance (QA) testing in accordance with the MDOT specifications.
- Perform all workmanship and materials for soil erosion, sanitary sewer covers and adjustments, gate valve and gate well covers and adjustments shall be in accordance with the Oakland County Water Resource Commissioners Standards, Details, and Specifications; and the Oakland County Water Resource Commissioners Soil Erosion Control permit.
- Provide local traffic access to residents along each city street for the duration of the project unless the City of Pontiac approves any closure.
- The Contractor shall cooperate and coordinate construction activities with the owners of utilities as stated in Section 104.08 of the 2012 Michigan Department of Transportation (MDOT) Standard Specifications for Construction. In addition, for the protection of underground utilities, the Contractor shall follow the requirements in Section 107.12 of the 2012 MDOT Standard Specifications for Construction, and the Oakland County Water Resources Commissioner and the technical specifications included in these bid documents. Contractor delay claims, resulting from a utility, will be determined based upon Section 109.05E of the 2012 MDOT Standard Specifications for Construction.

The City of Pontiac is the governing agency and any reference to the Michigan Department of Transportation shall be interpreted as the City of Pontiac. Unit prices are required for all items in each part of the Bid Schedule.

2018 ROADWAY MAINTENANCE PROGRAM

| No. | Items | Level 1 | Level 2 | Level 3 | Level 4 | Unit |
|-----|--|----------|----------|-----------|---------|------|
| 1 | Remove & Replace 4-inch Sidewalk (Residential) | | | | | |
| | Quantity | 1-500 | 501-1500 | 1501-5000 | 5001+ | SF |
| | Unit Price | \$ 14.00 | 12.50 | 10.00 | 9.00 | |
| 2 | Remove & Replace 6-inch Sidewalk (Residential and adjacent to driveways) | | | | | |
| | Quantity | 1-250 | 251-750 | 751-1500 | 1501+ | SF |
| | Unit Price | \$ 14.25 | 14.25 | 14.00 | 13.75 | |
| 3 | Remove & Replace 9-inch Sidewalk (Commercial/Industrial and adjacent to driveways) | | | | | |
| | Quantity | 1-250 | 251-750 | 751-1500 | 1501+ | SF |
| | Unit Price | \$ 19.50 | 16.25 | 15.00 | 14.00 | |
| 4 | Remove Sidewalk & Replace with ADA Ramp with Detectable Warning | | | | | |
| | Quantity | 1-400 | 401-800 | 801-3200 | 3201+ | SF |
| | Unit Price | 65.00 | 60.00 | 58.00 | 55.00 | |
| 5 | Remove & Replace Concrete Drive Approach, 6" (Residential) | | | | | |
| | Quantity | 1-500 | 501-1000 | 1001-2500 | 2501+ | SF |
| | Unit Price | 15.00 | 15.00 | 14.75 | 14.50 | |
| 6 | Remove and Replace Concrete Drive Approach, 9" (Commercial / Industrial) | | | | | |
| | Quantity | 1-500 | 501-1000 | 1001-5000 | 5000+ | SF |
| | Unit Price | 17.25 | 17.25 | 17.00 | 16.75 | |
| 7 | Restoration | | | | | |
| | Quantity | 1-500 | 501-2500 | 2501-7500 | 7501+ | SYD |
| | Unit Price | 8.50 | 8.25 | 8.00 | 7.50 | |
| 8 | Remove & Replace Concrete Curb & Gutter | | | | | |
| | Quantity | 1-50 | 51-250 | 251-1320 | 1321+ | LF |
| | Unit Price | 125.00 | 115.00 | 70.00 | 65.00 | |
| 9 | Remove HMA Surface | | | | | |
| | Quantity | 1-10 | 11-50 | 51-500 | 501+ | SYD |
| | Unit Price | 25.00 | 25.00 | 20.00 | 20.00 | |
| 10 | Cold Mill HMA Surface, 4" Thickness or Less | | | | | |
| | Quantity | 1-150 | 151-500 | 501-2000 | 2000+ | SYD |
| | Unit Price | 40.00 | 35.00 | 32.00 | 28.00 | |
| 11 | Install HMA, 1300 T, 20AAA Overlay | | | | | |
| | Quantity | 1-50 | 51-200 | 201-500 | 501+ | Ton |
| | Unit Price | 570.00 | 570.00 | 475.00 | 400.00 | |
| 12 | Install HMA, 1300 L, 20AAA Leveling / Base Course | | | | | |
| | Quantity | 1-50 | 51-200 | 201-500 | 501+ | Ton |
| | Unit Price | 570.00 | 570.00 | 475.00 | 400.00 | |
| 13 | HMA Hand Patching, 1300 T, 20AAA | | | | | |
| | Quantity | 1-10 | 11-25 | 26-50 | 50+ | Ton |
| | Unit Price | 600.00 | 600.00 | 575.00 | 525.00 | |
| 14 | Remove and Replace Concrete Pavement, 9 In., Non-Reinforced | | | | | |
| | Quantity | 1-10 | 11-50 | 51-500 | 501+ | SYD |
| | Unit Price | 180.00 | 180.00 | 170.00 | 160.00 | |

| No. | Items | Level 1 | Level 2 | Level 3 | Level 4 | Unit | |
|-----|---|----------|---------|---------|----------|----------|--|
| 15 | Epoxy Anchored Lane Ties | | | | | EA | |
| | Quantity | 1-10 | 11-50 | 51-500 | 501+ | | |
| | Unit Price | 15.00 | 12.50 | 9 | 9 | | |
| 16 | Aggregate Base, 21AA, 6 In., Limestone | | | | | SYD | |
| | Quantity | 1-10 | 11-50 | 51-500 | 501+ | | |
| | Unit Price | 25.00 | 25.00 | 20.00 | 20.00 | | |
| 17 | Aggregate Base, 21AA, 6 In., Crushed Concrete | | | | | SYD | |
| | Quantity | 1-10 | 11-50 | 51-500 | 501+ | | |
| | Unit Price | 20.00 | 20.00 | 15.00 | 12.00 | | |
| 18 | Subgrade Undercutting, 21AA, Crushed Concrete | | | | | CYD | |
| | Quantity | 1-25 | 26-100 | 101-500 | 501+ | | |
| | Unit Price | 120.00 | 120.00 | 110.00 | 100.00 | | |
| 19 | Items | Level 1 | Level 2 | Level 3 | Level 4 | EA | |
| | Drainage Structure Repair-2'-4' Dia. | | | | | | |
| | Quantity | 1-5 | 6-10 | 11-20 | 21+ | | |
| 20 | Replace Existing Drainage Structure, 2' Dia. | | | | | EA | |
| | Quantity | 1-5 | 6-10 | 11-20 | 21+ | | |
| | Unit Price | 2,975.00 | 2850.00 | 2675.00 | 2,500.00 | | |
| 21 | Replace Existing Drainage Structure, 4' Dia. | | | | | EA | |
| | Quantity | 1-5 | 6-10 | 11-20 | 21+ | | |
| | Unit Price | 4,500.00 | 4300.00 | 4200.00 | 4,000.00 | | |
| 22 | Replace Existing Drainage Structure, 4' Dia., 8'-15' Deep | | | | | FT | |
| | Quantity | 1-5 | 6-10 | 11-20 | 21+ | | |
| | Unit Price | 500.00 | 500.00 | 450.00 | 400.00 | | |
| 23 | Drainage Structure Cover Adjustment (raise/lower), Case 1 | | | | | EA | |
| | Quantity | 1-5 | 6-10 | 11-20 | 21+ | | |
| | Unit Price | 875.00 | 850.00 | 825.00 | 800.00 | | |
| 24 | Drainage Structure Cover Adjustment (raise/lower), Case 2 | | | | | EA | |
| | Quantity | 1-5 | 6-10 | 11-20 | 21+ | | |
| | Unit Price | 775.00 | 750.00 | 725.00 | 700.00 | | |
| 25 | Storm Sewer Replacement-12-Inch Diameter RCP | | | | | LF | |
| | Quantity | 1-50 | 51-150 | 151-500 | 500+ | | |
| | Unit Price | 220.00 | 200.00 | 175.00 | 150.00 | | |
| 26 | Storm Sewer Replacement-18-Inch Diameter RCP | | | | | LF JW | |
| | Quantity | 1-50 | 51-150 | 151-500 | 500+ | | |
| | Unit Price | 250.00 | 245.00 | 240.00 | 230.00 | | |
| 27 | Storm Sewer Replacement-21-Inch Diameter RCP | | | | | LF | |
| | Quantity | 1-50 | 51-150 | 151-500 | 500+ | | |
| | Unit Price | 310.00 | 305.00 | 300.00 | 290.00 | | |
| 28 | Storm Sewer Replacement-24-Inch Diameter RCP | | | | | LF | |
| | Quantity | 1-50 | 51-150 | 151-500 | 500+ | | |
| | Unit Price | 350.00 | 340.00 | 330.00 | 300.00 | | |

Attachment A - MDOT Frequently Used Special Provisions

The following MDOT Frequently Used Special Provisions are applicable and adhered to as part of this project. These documents take precedent over the 2012 MDOT Standard Specifications for Construction, and are included in Attachment A. This list may not be considered complete.
The following Special Provisions can be downloaded from the MDOT website at <https://mdotiboss.state.mi.us/SpecProv/specProvHome.htm>:

- 12SP-501A-01 Sampling Asphalt Binder on Local Agency Projects
- 12SP-501J-05 Acceptance of Hot Mix Asphalt Mixture on Local Agency Projects
- 12SP-604B-09 Quality Control and Acceptance of Portland Cement Concrete
- 12SP-812C-01 Traffic Control Quality and Compliance
- 12SP-812L-01 Supports for Temporary Signs
- 12SP-812U-01 Type III Barricades
- 12SP-910A-01 Physical Requirements for Geotextiles

I attest that the bid includes all information necessary for the City of Pontiac to accept the bid.

FIRM NAME, ADDRESS AND PHONE NUMBER:

**GREAT LAKES CONTRACTING
SOLUTIONS, LLC
2300 Edinburgh
Waterford, MI 48328**

Phone: 313-962-0400 | Fax: 313-962-0404

Dated and signed at Waterford, MI on 5/24/18
(City) (Date)

Name of Respondent: Philip A. Sakalian

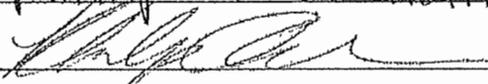
Signature of Respondent: 

Address of Respondent: 2300 Edinburgh, Waterford, MI 48328

By: Philip A. Sakalian Title: Owner/Member

Office # 313-962-0400 Cell # 248-838-8699
Tom Wall

FAX# 313-962-0404 FEDERAL TAX I.D. NUMBER 27-1826445

EMAIL Address of Primary Contact: home.greatlakescont.com

In witness whereof, the parties hereto have affixed, on duplicate originals, their signatures on the date indicated below, after first being authorized so to do.

Great Lakes Contracting Solutions, LLC.

6/22/18

DATE

Sign: 

Print: Philip A. Sakalian

Title: Owner/MEMBER

City of Pontiac

6/22/18

DATE

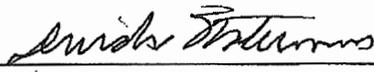
Sign: 

Print: Deirdre Waterman

Title: Mayor

#7

RESOLUTION



July 7, 2021

Great Lakes Power & Lighting
Attn: Mr. Charles Schwab, President
9646 Marine City Highway
Casco, MI 48604

Dear Mr. Schwab,

The City of Pontiac and Great Lakes Power & Lighting hereby mutually agree to extend the contract for "**Street Light Maintenance**" between the City of Pontiac and Great Lakes Power & Lighting originally dated June 28, 2017 for an effective date of January 1, 2021. **This agreed upon contract extension shall terminate at midnight January 1, 2022.**

This contract extension is created in accordance with Section VI Agreement within the contract documents.

This correspondence will serve as our contractual agreement to extend the above-mentioned contract based on the terms and conditions along with subsequent modifications, if any, as outlined in our agreement dated June 28, 2017.

Thank you for your continued service and dedication. We look forward to working with you and your team this contract year.

If you have any questions, or concerns, please feel free to contact me at 248.758.3617.

Sincerely,

CITY OF PONTIAC

By: _____ Date: _____
Al Cooley III Deputy DPW Director, City of Pontiac

Agreed: _____ Date: _____
Charles Schwab, President
Great Lakes Power & Lighting

I concur: _____ Date: _____
Deirdre Waterman, Mayor, City of Pontiac
AC/jc



CITY OF PONTIAC

OFFICIAL MEMORANDUM

Executive Branch

TO: Pontiac City Council

FROM: Deidre Waterman, Mayor, at the request of
Allen H. Cooley III, Deputy Director of DPW

DATE: June 29, 2021

RE: **Great Lakes Power & Light Contract Extension**

In 2017, the City of Pontiac advertised for "Street Light Maintenance" and awarded a contract to Great Lakes P&L. This contract was a one-year contract with options for years two and three. In the three years working with Great Lakes P&L, they have been a very responsive company to work with. We feel that their work product and ability to respond to outages and repairs is the best we have seen since contracting out the street light maintenance. Additionally, their pricing is also some of the lowest in the area for parts and labor, saving the City money on costly repairs.

Great Lakes P&L has been a trusted contractor for the 3 years of this contract and has done exemplary work repairing our public lighting system. Their knowledge of the City's public lighting system is unmatched and takes time and effort to figure out and understand.

At this time, the original Great Lakes P&L contract has expired. The Department of Public Works is still in need of assistance for "Street Light Maintenance"

We request to extend the current contract with Great Lakes P&L who has agreed to maintain current pricing. We are requesting to extend this contract for a period of 1 year.

Funding for this contract is in the Major Street Fund.

Based upon the above and attached information, it is the recommendation of the Department of Public Works to extend the contract with Great Lakes P&L for 1 year.

WHEREAS, The City of Pontiac has mutually agreed with Great Lakes P&L to extend the contract for 1 year at current rates;

WHEREAS, Great Lakes P&L has done exemplary work over the 3 years of their contract;

WHEREAS, The Department of Public Works is still in need of assistance for "Street Light Maintenance";

NOW, THEREFORE,
BE IT RESOLVED, The Pontiac City Council authorizes the Mayor to extend the contract with Great Lakes P&L until January 1, 2022.

AHC



DPW CONTRACTOR SCORECARD

| Topic: | Score | Targeted Score |
|---|---------------|-----------------------|
| Attendance: | | |
| <ul style="list-style-type: none"> Employees meet scheduled work hours | 10 | 10 |
| Work Place Accidents: | | |
| <ul style="list-style-type: none"> # of Incidents | 0/10 | 10 |
| <ul style="list-style-type: none"> Cost of Incidents: | 0/10 | 10 |
| Facility Supervisor Satisfaction: | | |
| <ul style="list-style-type: none"> Direct Program | 8 | 10 |
| <ul style="list-style-type: none"> Deputy Director | 8 | 10 |
| <ul style="list-style-type: none"> DPW Director | 8 | 10 |
| Emergency Response Rating: | | |
| <ul style="list-style-type: none"> COVID Response | 8 | 10 |
| Overall Communication and Response: | | |
| <ul style="list-style-type: none"> Sr. Management | 8 | 10 |
| <ul style="list-style-type: none"> Foreman | 8 | 10 |
| Proposed Program Enhancements: | | |
| <ul style="list-style-type: none"> Discounts/cost savings initiatives | 8 | 10 |
| Other Considerations: | | |
| Supplies/Materials/Equipment | 9 | 10 |
| Total Score: | 95 | 110 |
| 0-84 | RED | Unsatisfactory |
| 85-90 | YELLOW | Satisfactory |
| 91-100 | GREEN | Goal Met |

CONTRACT FOR STREET LIGHT MAINTENANCE

- 1) Parties. The parties to this contract are the City of Pontiac, Michigan hereinafter referred to as the "City", and Great Lakes Power & Lighting hereinafter called the "Contractor".
- 2) Purpose. The purpose of this contract is for the City to engage the Contractor to provide City Street Light Maintenance to the City, as the City deems necessary. (See Scope of Services below).
- 3) Scope of Services. The Contractor will provide all labor, limited materials, supplies, equipment and supervision to perform Street Light Maintenance in the City. The Contractor is to perform all work in accordance with generally accepted standards and practices.
- 4) General Terms and Conditions. This contract is hereby made subject to the terms and conditions included in the Scope of Services (see Exhibit "A" below) and Additional Terms and Conditions (see Exhibit "B" below).
- 5) Consideration. As consideration for the performance of the services referenced in the Scope of Services (see Exhibits "A" & "B" below), the City agrees to compensate the Contractor as follows:

Street Light Maintenance Bid Sheet (part 1 of 2)

CITY OF PONTIAC - BID PROPOSAL

I, the undersigned, propose to provide services proposed in this contract as per specifications supplied by the City of Pontiac. No contract is active until a purchase order is issued to the successful bidder. I further propose to deliver the above-described services for the City of Pontiac in first class operating manner in accordance with all specifications contained herein subject to purchaser's inspection of services performed.

I attest that the bid includes all information necessary for the City of Pontiac to accept bid.

FIRM NAME: Great Lakes Power & Light DATE: 5/22/17

BY: *CL* BY: Charles R Schwab President
 Signature Name and Title (print or type)

ADDRESS: 9646 26 Mile MI 48064
 Street City State Zip Code

OFFICE PHONE: 586 766 4000 CELL PHONE: 810 824 0075 FAX: 586 716 4770

NOTE: cost below should not include the cost of materials (i.e. bulbs, fuse and wire) only labor and equipment

| Item | Type of pole/fixture | Year 1 Cost | Year 2 Cost | Year 3 Cost |
|--|--------------------------|-------------|-------------|-------------|
| Standard Service Call Cost (for below items) | n/a | 50 | 60 | 70 |
| Additional cost to deploy 2nd crew | n/a | 50 | 60 | 70 |
| Emergency Service call (less than 24HR notice) | n/a | 50 | 60 | 72 |
| Re-wire Pole (cost per ft.) | Standard pole | 20 | 22 | 24 |
| Re-wire Pole (cost per ft.) | Decorative | 18 | 20 | 22 |
| Replace Bulb | Standard pole | 100 | 110 | 120 |
| Remove and Replace LED Fixture | Cobra Head LED | 220 | 240 | 260 |
| Remove and Replace LED Fixture | Decorative LED | 160 | 170 | 180 |
| Replace fuse | Standard/Decorative pole | 70 | 72 | 74 |
| Replace ballast | Standard/Decorative pole | 150 | 160 | 170 |
| Replace photocell | n/a | 100 | 110 | 120 |
| Service Call for Pole replacement | Standard pole | 50 | 60 | 70 |
| Emergency Service call for Pole replacement only (less than 24HR notice) | Standard pole | 50 | 60 | 70 |
| Replace Poles/support structures (wood) | Standard pole | 2500 | 2700 | 2900 |
| Replace Poles/support structures (aluminum) | Standard pole | 2900 | 3100 | 3300 |
| Standard Service call | n/a | 50 | 60 | 70 |
| Hourly Rate for electrician for items outside of scope | n/a | 64 | 66 | 68 |

Street Light Maintenance Bid Sheet (part 2 of 2)

CITY OF PONTIAC - BID PROPOSAL

I attest that the bid includes all information necessary for the City of Pontiac to accept bid.

FIRM NAME: Great Lakes Power & Lighting DATE: 5/22/17

BY: *CL* Signature BY: Charles R Schwab President Name and Title (print or type)

NOTE: cost below should not include the cost of materials (i.e. bulbs, fuse and wire) only labor and equipment

| Item | Type of pole/fixture | Year 1 Cost | Year 2 Cost | Year 3 Cost |
|--|----------------------|-------------|-------------|-------------|
| Emergency Service call for overhead wire only (less than 24HR notice) | n/a | 50 | 60 | 70 |
| Replace Overhead wire (cost per ft.) | n/a | 25 | 27 | 29 |
| Standard Service Call (underground wire only) Cost | n/a | 50 | 60 | 70 |
| Emergency Service call for underground wire only (less than 24HR notice) | n/a | 50 | 60 | 70 |
| Replace underground wire -excavation and repair (cost per linear ft.) cost should include backfill and restoration | n/a | 7 | 8 | 9 |
| Service call for directional drilling | n/a | 50 | 60 | 70 |
| Cost for directional drilling of conduit (per linear ft.) | n/a | 20 | 22 | 24 |
| Standard Service Call (diagnose wire break) Cost | n/a | 50 | 60 | 70 |
| Emergency Service call for diagnosing wire break (less than 24HR notice) | n/a | 50 | 60 | 70 |
| Cost per hour to diagnose a wire break or short | n/a | 64 | 66 | 68 |

Above pricing should include the cost of diagnostics

Example of how a job is billed for replacement of 5 bulbs and 1 fuse.
 =\$75 + \$100 (5X20) + \$15 = \$190 labor
 = \$5+\$50(10X5)=\$55 X 10% = \$60.5 materials
 Total bill =\$250.50
 Contractor pricing
 Standard Service Call \$75
 Replace Bulb \$20
 Replace Fuse \$15
 Materials
 Bulb \$10
 Fuse \$5

Disclaimer:

The City of Pontiac reserve the right to eliminate any of the work items listed above ,if the work is no longer required or is in the best interest of the City

The City of Pontiac reserves the right to bid out any work that would be deemed outside the scope of work , including but not limited to replacing traditional lights with LED fixtures

The Undersigned hereby declares that he/she or they are the only person(s), firm or corporation interested in this bid as principal, and that it is made without any connection with any other person(s), firm or corporation submitting a bid for the same.

The Undersigned hereby declares that they have read and understand all conditions are outlined in the Request for Bids and that the bid is made in accordance with same.

The Undersigned hereby declares that any person(s) employed by the City of Pontiac Michigan who has direct or indirect personal or financial interest in this bid or in any portion of the profits that may be derived therefrom has been identified and the interest disclosed by separate attachment. (Please include in your disclosure any interest which you know of. An example of a direct interest would be a City employee who would be paid to perform services under this bid. An example of an indirect interest would be a City employee who is related to any officers, employees, principal or shareholders of your firm or to you. If in doubt as to status or interest, please disclose to the extent known).

The proposer acknowledges the receipt of Addenda numbered _____

Note: Bids must bear the handwritten signature of a duly authorized member or employee of the organization submitting a bid.

Company Name: Great Lakes Power & Lighting

Address: 9646 26 Mile Rd Caseo MI 48064

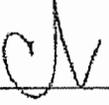
Representative Signature: 

Print Name: Charles R Schwab

Title: President

Office # 586 716 4000 Cell # 810 824 0075

FAX# 586 716 4770

Federal Tax Identification Number: 20-0682437

Date: 5/22/17

6) Period of Performance. This contract expires June 30, 2018, with the option for extension of the contract in one year increments for years two and or three, upon the approval and signature of the parties hereto. The Contractor is subject to the standard provision of City policy, of a 90 day review period. The City of Pontiac would inform the contractor a minimum of 30 days prior to expiration to enact optional years two and or three. The City has the right to break the agreement with 30 days' notice.

7) Method of Payment. Contractor will be paid 30 days after completion of work as outlined in the Scope of Services after submission of a valid invoice.

8) Applicable Law. This contract shall be governed by and construed in accordance with the laws of the City of Pontiac, State of Michigan and applicable federal laws.

9) Compliance with Laws. The Contractor understands that the City is an equal opportunity employer and, therefore, maintains a policy which prohibits unlawful discrimination based on race, color, creed, sex, age, national origin, physical handicap, disability, genetic information, or any other consideration made unlawful by federal, state, or local laws. All such discrimination is unlawful and the Contractor agrees during the term of the agreement that the Contractor will strictly adhere to this policy in its employment practices and provision of services. The Contractor shall comply with, and all activities under this agreement shall be subject to, all applicable federal, State of Michigan, and City of Pontiac laws and regulations, as now existing and as may be amended or modified.

The Contractor is responsible for instructing and training their employees in appropriate safety measures. Employees will be responsible for maintaining a safe work environment while completing their tasks.

- a) The Contractor shall comply with the Michigan Right to Know Law (Amendments to Act 154), which requires that all employers within the State comply with federal Hazard Communications Standards (C.F.R. 1910.1200) and certain additional guidelines as of February 25, 1987. These Standards specify that employers develop a written hazard communication program, which is to be made available for workers or their designated representatives.
- b) The Contractor will comply with all federal, state and local regulations, including but not limited to all applicable OSHA/MIOSHA requirements and the Americans with Disabilities Act
- c) The Contractor is responsible for all applicable state and federal social security benefits and unemployment taxes and agrees to indemnify and protect the City against such liability.

10) Requirements contract. During the period of the contract, the Contractor shall provide all the services described in the contract. The Contractor understands and agrees that this is a

requirements contract and that the City shall have no obligation to the Contractor if no services are required.

EXHIBIT "A"

SCOPE OF SERVICES

The Contractor shall provide Street Light Maintenance.

Except as otherwise provided herein, Contractor shall furnish all labor, supervision and services necessary to properly execute and complete the work.

The City of Pontiac is seeking a qualified contractor to do City Street Light Maintenance for the City of Pontiac. The successful bidder shall demonstrate past experience in City Street Light Maintenance for at least two years.

The City of Pontiac owns 2,124 street lights that vary from LEDs, High Pressure Sodium and Mercury Vapor lights. The breakdown is as follows:

| <u>Current Watt</u> | <u>Quantity</u> | <u>Current Watt</u> | <u>Quantity</u> |
|---------------------|-----------------|---------------------|-----------------|
| 175 MV | 87 | 060-069 LED | 93 |
| 400 MV | 182 | 120-129 LED | 285 |
| | | 150-159 LED | 111 |
| 100 HPS | 68 | 180-189 LED | 62 |
| 150 HPS | 449 | 250-259 LED | 90 |
| 250 HPS | 370 | 300-309 LED | 5 |
| 310 HPS | 28 | | |
| 400 HPS | 294 | | |

Contractor shall comply with all applicable O.S.H.A, M.U.T.C.D and M.I.O.S.H.A. laws and regulations. The Contractor shall furnish the necessary personnel for the services to be provided hereunder, such personnel to be employees of Contractor. Contractor shall provide the services hereunder as an independent contractor, and nothing herein contained shall be construed to be inconsistent with this relationship or status.

All employees will be required to wear safety articles as required by law at the sole cost of the contractor.

Materials:

1. The City of Pontiac may supply all the street lighting materials, or contract with the necessary vendor for the winning bidder to pick up the materials needed for a job.
2. Materials that are provided by the contractor will need a materials invoice with the submission of an invoice, of work done, to the City.

3. The City of Pontiac will not provide any storage for equipment or materials.

Scope of Services:

1. Repair. Perform electrical, electronic, and mechanical diagnostics on street lights and poles to determine reason for light failure.
 - a. Re-wire (in pole, above and below ground)
 - b. Replace bulb(s)
 - c. Remove and replace LED fixtures
 - d. Replace fuses
 - e. Replace circuit/breakers
 - f. Replace ballast(s)
 - g. Replace poles/support structures
 - h. Replace photocell(s)
 - i. Issue detailed monthly activity reports
 - j. Contractor to supply all materials

2. Maintain.
 - a. Develop and implement a preventative maintenance program (Contractor to include a detailed preventative maintenance program. i.e. change bulbs every 2.5 years)
 - 1)Detailed reporting function

3. Equipment.
 - a. List equipment intended to perform scope of work (please indicated if you rent or own)

4. Requirements.
 - a. Licenses
 - 1)Electrical
 - 2)CDL
 - b. Coordinate with Miss Dig when required
 - c. Coordinate with DTE when necessary
 - d. No permits will be required
 - e. Properly disposing of waste

5. Service and Response Time.
 - a. 24/7/365 on-call service
 - b. Twenty-four hour response time to light failures

EXHIBIT "B"

ADDITIONAL TERMS AND CONDITIONS

- 1) Attorneys' fees and expenses. Subject to other terms and conditions of this contract, in the event the Contractor defaults in any obligation under this contract, the Contractor shall pay to the City all costs and expenses (including, without limitation, investigative fees, court costs, and attorneys' fees) incurred by the City in enforcing this contract or otherwise reasonably related thereto. Contractor agrees that under no circumstances shall the City be obligated to pay any attorneys' fees or costs of legal action to the Contractor.
- 2) Authority to contract. The Contractor warrants: (a) that it is a validly organized business with valid authority to enter into this contract; (b) that it is qualified to do business and in good standing in the State of Michigan; (c) that entry into and performance under this contract is not restricted or prohibited by any loan, security, financing, contractual, or other contract of any kind; and, (d) notwithstanding any other provision of this contract to the contrary, that there are no existing legal proceedings or prospective legal proceedings, either voluntary or otherwise, which may adversely affect its ability to perform its obligations under this contract.
- 3) Confidential information. Disclosure of any confidential information by the Contractor or its subcontractor without the express written approval of the City shall result in the immediate termination of this contract.
- 4) Confidentiality. Notwithstanding any provision to the contrary contained herein, it is recognized that the City of Pontiac is a public City of the State of Michigan and is subject to the laws regarding confidentiality. If a public records request is made for any information provided to the City pursuant to the contract, the City shall promptly notify the disclosing party of such request and will respond to the request only in accordance with the procedures and limitations set forth in applicable law. The disclosing party shall promptly institute appropriate legal proceedings to protect its information. No party to the contract shall be liable to the other party for disclosures of information required by court order or required by law.
- 5) Contractor personnel. The City shall, throughout the life of the contract, have the right of reasonable rejection and approval of staff or subcontractors assigned to the work by the Contractor. If the City reasonably rejects staff or subcontractors, the Contractor shall provide replacement staff or subcontractors satisfactory to the City in a timely manner and at no additional cost to the City. The day-to-day supervision and control of the Contractor's employees and subcontractors is the sole responsibility of the Contractor. Contractor personnel are subject to background checks by the Oakland County Sheriff Department and shall comply with all requirements as outlined in the Request for Quote.

- 6) Insurance. The contractor, or any of their subcontractors, shall not commence work under this contract until they have obtained the insurance required under this paragraph, and shall keep such insurance in force during the entire life of this contract. All coverage shall be with insurance companies licensed and admitted to do business in the State of Michigan and acceptable to the City of Pontiac. The requirements below should not be interpreted to limit the liability of the Contractor. All deductibles and SIR's are the responsibility of the Contractor.
- a) Workers' Compensation Insurance. The Contractor shall procure and maintain during the life of this contract, Workers' Insurance, including Employers Liability Coverage, in accordance with all applicable statutes of the State of Michigan with a minimum limit of \$100,000 each accident for any employee.
 - b) Commercial General Liability Insurance. The Contractor shall procure and maintain during the life of this contract, Commercial General Liability Insurance on an "Occurrence Basis" with limits of liability not less than \$2,000,000 per occurrence and aggregate for Personal Injury, Bodily Injury and Property Damage, coverage shall include the following extensions: (A) Contractual Liability; (B) Products and Completed Operations; (C) Independent Contractors Coverage; (D) Broad Form General Liability Extensions or equivalent; (E) Deletion of all Explosion, Collapse and Underground (XCU) Exclusions, if applicable; (F) Per project aggregate.
 - c) Motor Vehicle Liability. The Contractor shall procure and maintain during the life of this contract Motor Vehicle Liability Insurance, including Michigan No-Fault Coverage, with limits of liability of not less than \$2,000,000 per occurrence combined single limit Bodily Injury and Property Damage. Coverage shall include all owned vehicles, all non-owned vehicles, and all hired vehicles.
 - d) Additional Insured: Commercial General Liability and Motor Vehicle Liability Insurance, as described above, shall include an endorsement stating the following shall be Additionally Insured: The City of Pontiac, all elected and appointed officials, all employees and volunteers, all boards, commissions, and/or authorities and board members, including employees and volunteers. It is understood and agreed by naming The City of Pontiac as additional insured, coverage afforded is considered to be primary and any other insurance The City of Pontiac may have in effect shall be considered secondary and/or excess.
 - e) Cancellation Notice: All policies, as described above, shall include an endorsement stating that it is understood and agreed Thirty (30) days, Ten (10) days for non-payment of premium, Advance Written Notice of Cancellation, Non-Renewal, Reduction, and/or Material Change shall be sent to: City Administrator for the City of Pontiac.

- f) Proof of Insurance Coverage: The Contractor shall provide The City of Pontiac at the time that the contracts are returned by him/her for execution, a Certificate of Insurance as well as the required endorsements. In lieu of required endorsements, if applicable, a copy of the policy sections where coverage is provided for additional insured and cancellation notice would be acceptable. Copies or certified copies of all policies mentioned above shall be furnished, if so requested.
- g) Expiration of Policies: If any of the above coverage expires during term of this contract, the Contractor shall deliver renewal certificates and/or policies to the City of Pontiac at least ten (10) days prior to the expiration date.
- h) Indemnification: To the extent permitted by law, the Contractor shall indemnify and hold the City harmless of and from all claims, losses, liability, demands, costs, loss of service, expense, and compensation on account of or in any way growing out of any damage, including, but not limited to, bodily injury or property damage which may result from the Contractor's services, In addition, the Contractor shall cover all costs incurred by the City in defense of any litigation covered under this letter of contract, including attorney fees and court costs.
- i) Insurance companies, named insureds and policy forms shall be subject to the approval of the Pontiac Department of Public Works. Such approval shall not be unreasonably withheld. Insurance policies shall not contain endorsements or policy conditions, which reduce coverage provided to the City of Pontiac. Contractor shall be responsible to the City of Pontiac or insurance companies insuring the City of Pontiac for all costs resulting from both financially unsound insurance companies selected by Contractor and their inadequate insurance coverage. Contractor shall furnish the Pontiac Finance Department with satisfactory certificates of insurance or a certified copy of the policy, if requested by the Finance Department.
- j) No payments will be made to the Contractor until the current certificates of insurance have been received and approved by the Finance Department. If the insurance as evidenced by the certificates furnished by the Contractor expires or is canceled during the term of the contract, services and related payments will be suspended. Contractor shall furnish the Finance Department with certification of insurance evidencing such coverage and endorsements at least ten (10) working days prior to commencement of services under this contract. Certificates shall be addressed to the Pontiac Finance Department, and shall provide for 30 day written notice to the Certificate holder of cancellation of coverage.
- 7) Ineligibility and suspension. The Contractor certifies to the best of its knowledge and belief, that it: (a) is not presently ineligible, suspended, proposed for ineligibility, declared ineligible, or voluntarily excluded from covered transaction by any federal department or the City or any political subdivision of the City or the State of Michigan; (b) has not, within a three year period preceding this proposal, been convicted of or had

civil judgment rendered against it for commission of fraud or a criminal offense in connection with obtaining, attempting to obtain, or performing a public (federal, state, or local) transaction or contract under a public transaction; (c) has not, within a three year period preceding this proposal, been convicted of or had civil judgment rendered against it for a violation of Federal or State antitrust statutes or commission of embezzlement, theft, forgery, bribery, falsification or destruction of records, making false statements, or receiving stolen property; (d) is not presently indicted for or otherwise criminally or civilly charged by a governmental entity (federal, state or local) with commission of any of these offenses enumerated in paragraphs (b) and (c) of this certification; and, (e) has not, within a three year period preceding this proposal, had one or more public transactions (federal, state, or local) terminated for cause or default.

- 8) Disclosure of confidential information. In the event that either party to this contract receives notice that a third party requests divulgence of confidential or otherwise protected information and/or has served upon it subpoena or other validly issued administrative or judicial process ordering divulgence of confidential or otherwise protected information that party shall promptly inform the other party and thereafter respond in conformity with such subpoena to the extent mandated by law. This section shall survive the termination or completion of this contract.
- 9) Exceptions to confidential information. The Contractor and the City shall not be obligated to treat as confidential and proprietary any information disclosed by the other party ("disclosing party") which: (a) is rightfully known to the recipient prior to negotiations leading to this contract, other than information obtained in confidence under prior engagements; (b) is generally known or easily ascertainable by nonparties of ordinary skill in the business of the customer; (c) is released by the disclosing party to any other person, firm, or entity (including governmental agencies or bureaus) without restriction; (d) is independently developed by the recipient without any reliance on confidential information; (e) is or later becomes part of the public domain or may be lawfully obtained by the City or the Contractor from any nonparty; or, (f) is disclosed with the disclosing party's prior written consent.
- 10) Default. If the Contractor:
- a) Fails to supply complete labor and supervision in sufficient time and quantity to meet the City's progress schedule, as it may be modified;
 - b) Causes stoppage or delay of, or interference with, the project;
 - c) Fails to promptly pay its employees for work on the project;
 - d) Fails to pay worker's compensation or other employee benefits, withholding or any other taxes;

- e) Fails to comply with the safety provisions of the Contract or with any safety order, regulation or requirement of any governing authority having jurisdiction over this project;
- f) Makes unauthorized changes in supervisory personnel;
- g) Fails in performance or observance of any of the provisions of the contract;
- h) Files a voluntary petition in bankruptcy or is adjudicated insolvent;
- i) Obtains an order for relief under Section 301 of the Bankruptcy Code;
- j) Files any petition or fails to contest any petition filed seeking any reorganization or similar relief under any laws relating to bankruptcy, insolvency or other relief of debtors;
- k) Or seeks or consents to or is acquiescent in the appointment of a trustee, receiver or liquidator of any of its assets or property;
- l) Makes an assignment for the benefit of creditors; or
- m) Makes an admission, in writing, of its inability to pay its debts as they became due;

Then City, after giving Contractor written or oral (subsequently confirmed in writing) notice of such default and forty-eight (48) hours within which to cure such default, shall have the right to exercise any one or more of the following remedies:

- a) Require that Contractor utilize, at its own expense, additional labor, overtime labor (including Saturday and Sunday work) and additional shifts as necessary to overcome the consequences of any delay attributable to Contractor's default.
- b) Remedy the default by whatever means City may deem necessary or appropriate, including, but not limited to, correcting, furnishing, performing or otherwise completing the work, or any part thereof, by itself or through others (utilizing where appropriate any materials and equipment previously purchased for that purpose by Contractor) and deducting the cost thereof from any monies due or to become due to Contractor hereunder;
 - i) After giving Contractor an additional forty-eight (48) hours written (or oral, subsequently confirmed in writing) notice, terminate this Contract, without thereby waiving or releasing any rights or remedies against Contractor or its sureties, and, by itself or through others, take possession of the work, and all materials, equipment facilities, tools, scaffolds and appliances of Contractor relating to the work, for the

purposes of costs and other damages under the contract and for the breach thereof; and

- ii) Recover all reasonable attorneys' fees suffered or incurred by City by reason of, or as a result of, Contractor's default.

11) Failure to enforce. Failure by the City at any time to enforce the provisions of the contract shall not be construed as a waiver of any such provisions. Such failure to enforce shall not affect the validity of the contract or any part thereof or the right of the City to enforce any provision at any time in accordance with its terms.

12) Final payment. Upon satisfactory completion of the work performed under this contract, as a condition before final payment under this contract, or as a termination settlement under this contract, the Contractor shall execute and deliver to the City a release of all claims against the City arising under, or by virtue of, the contract, except claims which are specifically exempted by the Contractor to be set forth therein. Unless otherwise provided in this contract, by state law, or otherwise expressly agreed to by the parties in this contract, final payment under the contract or settlement upon termination of this contract shall not constitute waiver of the City's claims against the Contractor under this contract.

13) Force majeure. Each party shall be excused from performance for any period and to the extent that it is prevented from performing any obligation or service, in whole or in part, as a result of causes beyond the reasonable control and without the fault or negligence of such party and/or its subcontractors. Such acts shall include without limitation acts of God, strikes, lockouts, riots, and acts of war, epidemics, governmental regulations superimposed after the fact, fire, earthquakes, floods, or other natural disasters (the "force majeure events"). When such a cause arises, the Contractor shall notify the City immediately in writing of the cause of its inability to perform, how it affects its performance, and the anticipated duration of the inability to perform. Delays in delivery or in meeting completion dates due to force majeure events shall automatically extend such dates for a period equal to the duration of the delay caused by such events, unless the City determines it to be in its best interest to terminate the contract.

14) Indemnification. To the fullest extent allowed by law, the Contractor shall indemnify, defend, save and hold harmless, protect, and exonerate the City, its commissioners, board members, officers, employees, agents, representatives, and the State of Michigan from and against all claims, demands, liabilities, suits, actions, damages, losses, and costs of every kind and nature whatsoever including, without limitation, court costs, investigative fees and expenses, and attorneys' fees, arising out of or caused by the Contractor and/or its partners, principals, agents, employees and/or subcontractors in the performance of or failure to perform this contract. In the City's sole discretion, the Contractor may be allowed to control the defense of any such claim, suit, etc. In the

event the Contractor defends said claim, suit, etc., the Contractor shall use legal counsel acceptable to the City. The Contractor shall be solely responsible for all costs and/or expenses associated with such defense, and the City shall be entitled to participate in said defense. The Contractor shall not settle any claim, suit, etc., without the City's concurrence, which the City shall not unreasonably withhold.

15) Independent contractor status. The Contractor shall, at all times, be regarded as and shall be legally considered an independent contractor and shall at no time act as an agent for the City. Nothing contained herein shall be deemed or construed by the City, the Contractor, or any third party as creating the relationship of principal and agent, master and servant, partners, joint ventures, employer and employee, or any similar such relationship between the City and the Contractor. Neither the method of computation of fees or other charges, nor any other provision contained herein, nor any acts of the City or the Contractor hereunder creates, or shall be deemed to create, a relationship other than the independent relationship of the City and the Contractor. The Contractor's personnel shall not be deemed in any way, directly or indirectly, expressly or by implication, to be employees of the City or the State of Michigan. Neither the Contractor nor its employees shall, under any circumstances be considered servants, agents, or employees of the City and the City shall be at no time legally responsible for any negligence or other wrongdoing by the Contractor, its servants, agents, or employees. The City shall not withhold from the contract payments to the Contractor any federal or state unemployment taxes, federal or state income taxes, social security tax, or any other amounts for benefits to the Contractor. Further, the City shall not provide to the Contractor any insurance coverage or other benefits, including worker's compensation, normally provided by the City for its employees.

16) No limitation of liability. Nothing in this contract shall be interpreted as excluding or limiting any tort liability of the Contractor for harm caused by the intentional or reckless conduct of the Contractor or for damages incurred through the negligent performance of duties by the Contractor or the delivery of products that are defective due to negligent construction.

17) Notices. All notices required or permitted to be given under this contract shall be in writing and personally delivered or sent by certified United States mail, postage prepaid, return receipt requested, to the Pontiac City Clerk's Office to whom the notice should be given at the address set forth below. Notice shall be deemed given when actually received or when refused. The parties agree to promptly notify each other in writing of any change of address.

For the Contractor: Great Lakes Power & Lighting
9646 Marine City Hwy
Casco, MI 48604

For the City: City of Pontiac
47450 Woodward Ave.
Pontiac, MI 48342

- 18) Oral statements. No oral statement of any person shall modify or otherwise affect the terms, conditions, or specifications stated in this contract. All modifications to the contract shall be made in writing by the City and agreed to by the Contractor.
- 19) Ownership of documents and work papers. The City shall own all documents, files, reports, work papers and working documentation, electronic or otherwise, created in connection with the project which is the subject of this contract, except for the Contractor's internal administrative and quality assurance files and internal project correspondence. The Contractor shall deliver such documents and work papers to the City upon termination or completion of the contract. The foregoing notwithstanding, the Contractor shall be entitled to retain a set of such work papers for its files. The Contractor shall be entitled to use such work papers only after receiving written permission from the City and subject to any copyright protections.
- 20) Priority. The contract consists of this contract with exhibits. Any ambiguities, conflicts or questions of interpretation of this contract shall be resolved by first, reference to this contract with exhibits and, if still unresolved, by reference to the bid. Omission of any term or obligation from this contract shall not be deemed an omission from this contract if such term or obligation is provided for elsewhere in this contract.
- 21) Quality control. The Contractor shall institute and maintain throughout the contract period a properly documented quality control program designed to ensure that the services are provided at all times and in all respects in accordance with the contract. The program shall include providing daily supervision and conducting frequent inspections of the Contractor's staff and ensuring that accurate records are maintained describing the disposition of all complaints. The records so created shall be open to inspection by the City.
- 22) Record retention and access to records. Provided the Contractor is given reasonable advance written notice and such inspection is made during normal business hours of the Contractor, the City or any duly authorized representatives shall have unimpeded, prompt access to any of the Contractor's books, documents, papers, and/or records which are maintained or produced as a result of the project for the purpose of making audits, examinations, excerpts, and transcriptions. All records related to this contract shall be retained by the Contractor for three years after final payment is made under this contract and all pending matters are closed; however, if any audit, litigation or other action arising out of or related in any way to this project is commenced before the end of the three year period, the records shall be retained for one year after all issues

arising out of the action are finally resolved or until the end of the three year period, whichever is later.

- 23) Recovery of money. Whenever, under the contract, any sum of money shall be recoverable from or payable by the Contractor to the City, the same amount may be deducted from any sum due to the Contractor under the contract or under any other contract between the Contractor and the City. The rights of the City are in addition and without prejudice to any other right the City may have to claim the amount of any loss or damage suffered by the City on account of the acts or omissions of the Contractor.
- 24) Right to audit. The Contractor shall maintain such financial records and other records as may be prescribed by the City or by applicable federal and state laws, rules, and regulations. The Contractor shall retain these records for a period of three years after final payment, or until they are audited by the City, whichever event occurs first. These records shall be made available during the term of the contract and the subsequent three-year period for examination, transcription, and audit by the Michigan Office of the State Auditor, its designees, or other authorized bodies.
- 25) Right to inspect facility. The City may, at reasonable times, inspect the place of business of the Contractor or any subcontractor, which is related to the performance of any contract awarded by the City.
- 26) Severability. If any part of this contract is declared to be invalid or unenforceable, such invalidity or unenforceability shall not affect any other provision of the contract that can be given effect without the invalid or unenforceable provision, and to this end the provisions hereof are severable. In such event, the parties shall amend the contract as necessary to reflect the original intent of the parties and to bring any invalid or unenforceable provisions in compliance with applicable law.
- 27) City property. The Contractor will be responsible for the proper custody and care of any City-owned property furnished for the Contractor's use in connection with the performance of this contract. The Contractor will reimburse the City for any loss or damage, normal wear and tear excepted.
- 28) Termination for convenience clause.
 - a) The City reserves the absolute right to terminate the contract in whole or in part, for the convenience of the City at its sole discretion on thirty (30) days written notice to the Contractor. The City has the right, upon its sole discretion only, to terminate the contract with cause by giving notice to the Contractor of such termination, specifying the effective date thereof, at least fourteen (14) days before the effective date of such termination, and the Contract shall terminate in all respects as if such date were the date originally given for the expiration of the Contract.

- b) The Contractor shall be liable to the City for damages sustained by the City by virtue of any breach of the Contract by the Contractor, and any costs the City might incur enforcing or attempting to enforce the Contract, and the City may pursue legal remedies in the collection of fees to compensate for the damages sustained by the City.
- c) Contractor's Obligations. The Contractor shall incur no further obligations in connection with the terminated work and on the date set in the notice of termination the Contractor will stop work to the extent specified. The Contractor shall also terminate outstanding orders and subcontracts as they relate to the terminated work. The Contractor shall settle the liabilities and claims arising out of the termination of subcontracts and orders connected with the terminated work. The City may direct the Contractor to assign the Contractor's right, title, and interest under terminated orders or subcontracts to the State of Michigan. The Contractor shall still complete the work not terminated by the notice of termination and may incur obligations as are necessary to do so.

29) Termination for default clause.

- a) Default. If the Contractor refuses or fails to perform any of the provisions of this contract with such diligence as will ensure its completion within the time specified in this contract or any extension thereof, or otherwise fails to timely satisfy the contract provisions, or commits any other substantial breach of this contract, the City may notify the Contractor in writing of the delay or nonperformance and if not cured in ten days or any longer time specified in writing by the City, the City may terminate the Contractor's right to proceed with the contract or such part of the contract as to which there has been delay or a failure to properly perform. In the event of termination in whole or in part, the City may procure similar supplies or services in a manner and upon terms deemed appropriate by the City. The Contractor shall continue performance of the contract to the extent it is not terminated and shall be liable for excess costs incurred in procuring similar goods or services.
- b) Contractor's Duties. Notwithstanding termination of the contract and subject to any directions from the City, the Contractor shall take timely, reasonable, and necessary action to protect and preserve property in the possession of the Contractor in which the City has an interest.
- c) Compensation. Payment for completed services delivered and accepted by the City shall be at the contract price. The City may withhold from amounts due the Contractor such sums as the City deems to be necessary to protect the City against loss because of outstanding liens or claims of former lien holders and to reimburse the City for the excess costs incurred in procuring similar goods and services.

- d) Excuse for Nonperformance or Delayed Performance. Except with respect to defaults of subcontractors, the Contractor shall not be in default by reason of any failure in performance of this contract in accordance with its terms (including any failure by the Contractor to make progress in the prosecution of the work hereunder which endangers such performance) if the Contractor has notified the City within 15 days after the cause of the delay and the failure arises out of causes such as: acts of God; acts of the public enemy; acts of the State of Michigan and any other governmental entity in its sovereign or contractual capacity; fires; floods; epidemics; quarantine restrictions; strikes or other labor disputes; freight embargoes; or unusually severe weather. If the failure to perform caused by the failure of a subcontractor to perform or to make progress, and if such failure arises out of causes similar to those set forth above, the Contractor shall not be deemed to be in default, unless the services to be furnished by the subcontractor were reasonably obtainable from other sources in sufficient time to permit the Contractor to meet the contract requirements. Upon request of the Contractor, the City shall ascertain the facts and extent of such failure, and, if such officer determines that any failure to perform was occasioned by any one or more of the excusable causes, and that, but for the excusable cause, the Contractor's progress and performance would have met the terms of the contract, the delivery schedule shall be revised accordingly, subject to the rights of the City under the clause entitled "Termination for Convenience." (As used in this paragraph, the term "subcontractor" means subcontractor at any tier).
- e) Erroneous Termination for Default. If, after notice of termination of the Contractor's right to proceed under the provisions of this clause, it is determined for any reason that the contract was not in default under the provisions of this clause, or that the delay was excusable under the provisions of Paragraph (d) (Excuse for Nonperformance or Delayed Performance) of this clause, the rights and obligations of the parties shall, if the contract contains a clause providing for termination for convenience by the City, be the same as if the notice of termination had been issued pursuant to such clause.
- f) Additional Rights and Remedies. The rights and remedies provided in this clause are in addition to any other rights and remedies provided by law or under this contract.
- 30) Termination upon bankruptcy. This contract may be terminated in whole or in part by the City upon written notice to the Contractor, if the Contractor should become the subject of bankruptcy or receivership proceedings, whether voluntary or involuntary, or upon the execution by the Contractor of an assignment for the benefit of its creditors. In the event of such termination, the Contractor shall be entitled to recover just and equitable compensation for satisfactory work performed under this contract, but in no case shall said compensation exceed the total contract price.

- 31) Third party action notification. The Contractor shall give the City prompt notice in writing of any action or suit filed, and prompt notice of any claim made against the Contractor by any entity that may result in litigation related in any way to this contract.
- 32) Unsatisfactory work. If, at any time during the contract term, the service performed or work done by the Contractor is considered by the City to create a condition that threatens the health, safety, or welfare of the citizens and/or employees of the City of Pontiac, the Contractor shall, on being notified by the City, immediately correct such deficient service or work. In the event the Contractor fails, after notice, to correct the deficient service or work immediately, the City shall have the right to order the correction of the deficiency by separate contract or with its own resources at the expense of the Contractor.
- 33) Waiver. No delay or omission by either party to this contract in exercising any right, power, or remedy hereunder or otherwise afforded by contract, at law, or in equity shall constitute an acquiescence therein, impair any other right, power or remedy hereunder or otherwise afforded by any means, or operate as a waiver of such right, power, or remedy. No waiver by either party to this contract shall be valid unless set forth in writing by the party making said waiver. No waiver of or modification to any term or condition of this contract will void, waive, or change any other term or condition. No waiver by one party to this contract of a default by the other party will imply, be construed as, or require waiver of future or other defaults.
- 34) Taxes and Contributions. The Contractor hereby accepts and assumes exclusive liability for and shall indemnify, protect and save harmless the City from and against the payment of:
- a) Contractor agrees to contact the City of Pontiac Income Tax Division, Audit and Compliance Section, 47450 Woodward, Pontiac, Michigan 48342, to establish reporting and withholding obligations under the City of Pontiac Income Tax Ordinance. Contractors will require the same of all subcontractors employed to perform any work in the City of Pontiac.

Web page URL: http://www.pontiac.mi.us/departments/income_tax/index.php
Tax forms URL: http://www.pontiac.mi.us/departments/income_tax/tax_forms.php
 - b) All contributions, taxes or premiums (including interest and penalties thereon) which may be payable under the Unemployment Insurance Law of any State, the Federal Social Security Act, Federal, State, County and/or Municipal Tax Withholding Act, Federal, State, County and/or Municipal Tax Withholding Laws, or any other law, measured upon the payroll of or required to be withheld from employees by whomsoever employed or engaged in the work to be performed and furnished under this contract.

- c) All sales, use, personal property and other taxes (including interest and penalties thereon) required by any Federal, State, County, Municipal or other law to be paid or collected by the Contractor or any of its vendors or any other person or persons acting for, through or under it or any of them, by reason of the performance of this work or the acquisition, furnishing, or use of any materials, equipment, supplies, labor, services or other items for or in connection with the work.
- d) All pension, welfare, vacation, annuity and other union benefit contributions payable, under or in connection with respect, to all persons; by whomsoever employed or engaged in the work to be performed and furnished under this Contract.

35) Bonds. The Contractor is required to execute bonds, with sureties acceptable to the City, as identified in the specifications, all of which are incorporated into this agreement.

In witness whereof, the parties hereto have affixed, on duplicate originals, their signatures on the date indicated below, after first being authorized so to do.

Great Lakes Power & Lighting

6.28.17
DATE

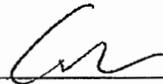
Sign: 

Print: CHARLES P. SCHLAB

Title: PRESIDENT

City of Pontiac

6.28.17
DATE

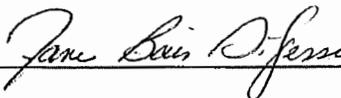
Sign: 

Print: JANE BAIS DISESSA

Title: Deputy Mayor

#8

RESOLUTION



CITY OF PONTIAC

OFFICIAL MEMORANDUM

Executive Branch

TO: Honorable Mayor, Council President and City Council Members

FROM: Abdul H. Siddiqui, City Engineer

DATE: July 13, 2021

RE: 2021 CDBG Sidewalk Improvement Project – Koala-T Construction, Inc.

The City of Pontiac received and publicly opened bids for the referenced improvement project on Thursday, June 24, 2021. The project involves the repair of damaged sidewalks in various neighborhoods of the City, funded by a Community Development Block Grant.

A total of three (3) bids were received for the project in the amounts as follows:

- | | |
|---|--------------|
| 1. Koala-T Construction, Inc. | \$663,400.75 |
| 2. Audia Concrete Construction, Inc. | \$718,775.25 |
| 3. Great Lakes Contracting Solutions, LLC | \$730,805.00 |

The Engineering Division has reviewed the proposals and references submitted by all contractors and based on the attached is recommending the award to the low bidder, Koala-T Construction, Inc.

Construction is scheduled to start in early August with anticipated completion within ninety (90) days.

Funding for the project will be through a Community Development Block Grant, administered by Oakland County, in the amount of \$481,616.00.

Based upon the above information, it is recommendation of the Department of Public Works that the 2021 CDBG Sidewalk Improvement Project be awarded to Koala-T Construction, Inc., in the amount of \$481,616.00.

WHEREAS, the City of Pontiac has advertised and received responses to a Request For Proposal for the 2021 CDBG Sidewalk Improvement Project on June 24, 2021, and publically opened bids; and

WHEREAS, a bid tabulation was prepared and reviewed, and;

WHEREAS, the City identified the low bidder as Koala-T Construction, Inc., and references of the low bidder checked and found acceptable.

NOW, THEREFORE,

BE IT RESOLVED, The Pontiac City Council authorizes the Mayor to enter into a contract with Koala-T Construction, Inc. for \$481,616.00 for the 2021 CDBG Sidewalk Improvement Project.

TABULATION OF BIDS
Project: 2021 CDBG Sidewalk Improvement Program
Client: City of Pontiac

City of Pontiac
 47450 Woodward Ave.
 Pontiac, MI 48236

Project Name: 2021 CDBG Sidewalk Improvement Program

Bids Opened: June 24, 2021

| ITEM | ITEM | QUANTITY |
|------|------------------------|-----------|
| 1 | Sidewalk, Ram | 7,615 SY |
| 2 | Sidewalk, Conc, 4 inch | 50,350 SF |
| 3 | Sidewalk, Conc, 6 inch | 13,615 SF |
| 4 | Sidewalk, Conc, 8 inch | 490 SF |
| 5 | Hand Patching | 25 TON |
| 6 | Root Removal | 525 EA |
| 7 | Stump Removal | 25 EA |
| 8 | Timber Wall | 200 LF |

| Engineer's Estimate: | | |
|--|---------------------|--|
| Nowak and Fraus Engineers | | |
| 46777 Woodward Ave. Pontiac, MI 48342 Ph: 248-332-7931 | | |
| UNIT PRICE | AMOUNT | |
| \$9.00 | \$68,535.00 | |
| \$6.50 | \$327,275.00 | |
| \$7.00 | \$95,305.00 | |
| \$8.00 | \$3,920.00 | |
| \$200.00 | \$5,000.00 | |
| \$100.00 | \$52,500.00 | |
| \$300.00 | \$7,500.00 | |
| \$50.00 | \$10,000.00 | |
| Total: | \$570,035.00 | |

| Low Bidder: | | |
|---|---------------------|--|
| Kosla-T Construction | | |
| 13448 Chateau Cove Holly, MI 48442 Ph: 248-322-2751 | | |
| UNIT PRICE | AMOUNT | |
| \$27.00 | \$206,605.00 | |
| \$6.15 | \$309,652.50 | |
| \$6.65 | \$90,539.75 | |
| \$9.65 | \$4,728.50 | |
| \$325.00 | \$8,125.00 | |
| \$50.00 | \$26,250.00 | |
| \$300.00 | \$7,500.00 | |
| \$55.00 | \$11,000.00 | |
| Total: | \$663,400.75 | |

| Second Bidder: | | |
|---|---------------------|--|
| Audia Construction | | |
| 2985 Childs Lake Road Millford, MI 48361 Ph: 248-678-9570 | | |
| UNIT PRICE | AMOUNT | |
| \$9.00 | \$68,535.00 | |
| \$8.35 | \$420,422.50 | |
| \$8.85 | \$120,492.75 | |
| \$10.00 | \$4,900.00 | |
| \$290.00 | \$7,250.00 | |
| \$145.00 | \$76,125.00 | |
| \$450.00 | \$11,250.00 | |
| \$49.00 | \$9,800.00 | |
| Total: | \$718,775.25 | |

| Third Bidder: | | |
|---|---------------------|--|
| Great Lakes Contracting Solutions | | |
| 2300 Edinburgh Waterford, MI 48328 Ph: 313-962-0400 | | |
| UNIT PRICE | AMOUNT | |
| \$15.00 | \$114,225.00 | |
| \$7.50 | \$377,625.00 | |
| \$8.00 | \$108,920.00 | |
| \$9.00 | \$4,410.00 | |
| \$425.00 | \$10,625.00 | |
| \$175.00 | \$91,875.00 | |
| \$525.00 | \$13,125.00 | |
| \$50.00 | \$10,000.00 | |
| Total: | \$730,805.00 | |

SPECIFICATIONS AND CONTRACT DOCUMENTS

FOR

CITY OF PONTIAC

DEPARTMENT OF PUBLIC WORKS
ENGINEERING DIVISION

2021 CDBG
SIDEWALK IMPROVEMENT PROGRAM



BIDS DUE:

Thursday June, 24, 2021
Time: 2:00 p.m.
City Clerks Office
Pontiac City Hall
47450 Woodward Avenue
Pontiac, MI 48342

PRE-BID MEETING:

Tuesday, June 1, 2021
Time: 10:00 a.m.
Online meeting
Login information to be provided

ENGINEER

NOWAK & FRAUS ENGINEERS
46777 WOODWARD AVENUE
PONTIAC, MI 48342
(248) 332-7931

NFE Job No.M309

CONTRACT DOCUMENTS
2021 CDBG SIDEWALK IMPROVEMENT PROGRAM

| <u>TABLE OF CONTENTS</u> | <u>PAGE</u> |
|---|--------------------|
| Table of Contents | <i>i-ii</i> |
| Advertisement | 1 |
| Instructions to Bidder Index | 2 |
| 1. Proposals to be Received | 3 |
| 2. Location of the Work | 3 |
| 3. Inspection of the Site | 3 |
| 4. Conformity to Plans, Specifications and other Contract Documents | 4 |
| 5. Basis on which Proposals are Solicited | 4-5 |
| 6. Form of Proposals | 6 |
| 7. Legal Status of Bidder | 6 |
| 8. Agency | 6 |
| 9. Bid Deposit | 6,7 |
| 10. INTENTIONALLY LEFT BLANK | 7 |
| 11. Statement of Bidder's Qualifications | 7 |
| 12. Payments | 8 |
| 13. Time of Completion | 8 |
| 14. Right to Accept, to Reject and to Waive Defects | 8 |
| 15. Award of Contract | 8 |
| 16. Obligation to Execute Contract | 8 |
| 17. Bonds | 9 |
| 18. Indemnification and Insurance | 9,10 |
| 19. City Income Tax | 10,11 |
| 20. Pre-Bid Meeting | 11 |
| 21. Intentionally Left Blank | 11 |
| Sample Insurance Certificate | 12 |
| Bid Forms | |
| 1. Form of Proposal (<u>4</u> Pages) | 13-16 |
| 2. Intentionally Left Blank | 17-18a |
| Agreement and Bonds | |
| 1. Bid Bond (Form) (<u>2</u> Pages) | 19,20 |
| 2. Agreement (Form) (<u>4</u> Pages) | 21-24 |
| 3. Bond for Faithful Performance (Form) | 25,26 |
| 4. Labor and Materials Bond to the City of Pontiac, Michigan (Form) | 27,28 |
| 5. Maintenance Bond (Form) | 29,30 |

TABLE OF CONTENTS (Continued)

PAGE

| | |
|--|-------|
| General Conditions | 31-51 |
| Index of General Conditions | 31 |
| 1. Definitions | 32-34 |
| 2. Plans and Specifications | 34,35 |
| 3. Shop Drawings | 35 |
| 4. Materials and Workmanship | 36 |
| 5. Superintendence by Contractor | 37,38 |
| 6. Engineering Supervision | 38,39 |
| 7. City's Right to Complete; Suspension or Termination | 39 |
| 8. Assignment of Contract | 39,40 |
| 9. Extra Work and Modification | 40,41 |
| 10. Disputed Claims for Extra Compensation | 40 |
| 11. Extension of Time | 40,41 |
| 12. Liquidated Damages | 41 |
| 13. Payments to the Contractor | 42-44 |
| 14. Warranty Maintenance | 44,45 |
| 15. Michigan Non-Discrimination Statute | 45 |
| 16. Labor Laws and Ordinances; Affirmative Action | 45 |
| 17. Patents, Patent Rights and Trademarks | 45 |
| 18. Work within Railroad, Private, State or County Right-of-Way | 45 |
| 19. Protection and Safety | 46-49 |
| 20. Cleaning Up | 49 |
| 21. Progress Schedule | 49,50 |
| 22. Contractor's Declaration | 51 |
| 23. Contractor's Affidavit | 52 |
| Notices to Bidders, Specifications and Special Provisions | 53-67 |
| Supplemental MDOT Special Provisions: Quality Control and Acceptance for Portland Cement Concrete | 1-21 |
| Appendix A: Exhibits 1-10 | |
| Appendix B: CBDG Specifications | |

**CITY OF PONTIAC
ADVERTISEMENT FOR BIDS**

Notice to Contractors

Sealed proposals will be received at the office of the City Clerk, City Hall, 47450 Woodward Avenue, Pontiac, Michigan 48342, until **2:00 p.m., local time, Thursday, June 24, 2021**, at which time the bids will be publicly opened and read by the Clerk and the amounts of the bids noted for the:

2021 CDBG SIDEWALK IMPROVEMENT PROGRAM

The estimated quantities involved in this work consist principally of the following:

| <u>Description</u> | <u>Unit</u> |
|---------------------------|-------------|
| 1) Sidewalk, Rem | 7,615 SY |
| 2) Sidewalk, Conc, 4 Inch | 50,350 SF |
| 3) Sidewalk, Conc, 6 Inch | 13,615 SF |
| 4) Sidewalk, Conc, 8 Inch | 490 SF |
| 5) Hand Patching | 25 TON |
| 6) Root Removal | 525 EACH |
| 7) Stump Removal | 25 EACH |
| 8) Timber Wall | 200 LF |

An online pre-bid meeting will be held at 10:00 a.m. Tuesday, June 1, 2021. Contract requirements and technical specifications will be discussed in said meeting and attendance is mandatory for all prospective bidders for submitting proposals.

A certified check or a satisfactory surety bid bond for a sum not less than five (5) percent of the amount of the proposal will be required with each proposal as a guarantee of good faith and same to be subject to the conditions stipulated in the Instructions to Bidders.

The bidder will be required to comply with Michigan statutory prohibitions against discrimination in employment and with employment opportunities for City of Pontiac residents.

No proposal once submitted may be withdrawn for at least 90 days after the actual opening of the bids.

The right to accept any proposal, to reject any or all proposals, and to waive defects in proposals, is reserved by the City.

**BY THE ORDER OF:
DIERDRE WATERMAN, MAYOR
CITY OF PONTIAC**

**DAN RINGO, ACTING DIRECTOR DPW
CITY OF PONTIAC**

INSTRUCTIONS TO BIDDERS

INDEX

Article

1. Proposal to be Received
2. Location of the Work
3. Inspection of the Site
4. Conformity to Plans, Specifications and Other Contract Documents
5. Basis on which Proposals are Solicited
6. Form of Proposal
7. Legal Status of Bidder
8. Agency
9. Bid Deposit
10. INTENTIONALLY LEFT BLANK
11. Statement of Bidder's Qualifications
12. Payments
13. Time of Completion
14. Right to Accept, to Reject, and to Waive Defects
15. Award of Contract
16. Obligation to Execute Contract
17. Bonds
18. Insurance
19. City Taxes
20. Pre-Bid Meeting
21. Intentionally Left Blank
22. Non-Discrimination Provision

INSTRUCTION TO BIDDERS

1. PROPOSALS TO BE RECEIVED

Sealed Bids or proposals for the:

2021 CDBG SIDEWALK IMPROVEMENT PROGRAM

will be received at the office of the City Clerk of the City of Pontiac, Michigan until **2:00 p.m., local time, on Thursday June 24, 2021**, and immediately thereafter will be publicly opened and read.

Each BID must be submitted in a sealed envelope, addressed to the City Clerk of the City of Pontiac. Each sealed envelope containing a BID must be plainly marked on the outside as:

“2021 CDBG SIDEWALK IMPROVEMENT PROGRAM”

and the envelope should bear on the outside the name of the BIDDER, his address, his license number (if applicable) and the name of the project for which the BID is submitted. If forwarded by mail, the sealed envelope containing the BID must be enclosed in another envelope addressed to the City Clerk, City of Pontiac, 47450 Woodward Ave., Pontiac, MI 48342.

Bids will be received during regular business hours at the place and up to the time stated in the Advertisement or up to the time extended by official notification. Bids may be delivered in person or mailed, but their delivery is the bidder's entire responsibility. Any bid received after the stated hour, even through the mail, will be returned unopened to the bidder.

No bidder may withdraw a bid within 90 days after the actual date of the opening thereof. Should there be reason why the contract cannot be awarded within the specified period, the time may be extended by mutual agreement between the City of Pontiac, herein after also referred to as the City, and the BIDDER.

2. LOCATION OF THE WORK

VARIOUS LOCATIONS THROUGH OUT THE CITY.
REFER APPENDIX A: EXHIBITS AND LOCATION MAPS.

3. INSPECTION OF THE SITE

It is expected that each bidder will make a personal examination of the entire site of the proposed work and of its surroundings. It will be assumed that each bidder, before offering his proposal, has obtained firsthand information concerning any probable interference and the available facilities for transporting, handling, and storing construction equipment and materials, and concerning other conditions which may affect his work.

4. CONFORMITY TO PLANS, SPECIFICATIONS AND CONTRACT DOCUMENTS

Proposals must be made in full conformity to all the conditions as set forth in the Plans, Specifications, and any Addendum for the work now on file in the office of the City Engineer. The CONTRACT DOCUMENTS contain the provisions required for the construction of the PROJECT. Information obtained from an officer, agent, or employee of the City or any other person shall not affect the risks or obligations assumed by the CONTRACTOR or relieve him from fulfilling any of the conditions of the contract.

Each BIDDER is responsible for inspecting the site and for reading and being thoroughly familiar with the CONTRACT DOCUMENTS. The failure or omission of any BIDDER to do any of the foregoing shall in no way relieve any BIDDER from any obligation in respect to his BID.

5. BASIS ON WHICH PROPOSALS ARE SOLICITED

A. PROPOSAL SOLICITATION

Proposals may be solicited on the basis of unit prices, lump sum, or a combination of both. The proposal will clearly state which basis is used.

The lump sum price, when applied to the project, or the unit prices, when applied to the several demolition or salvage items, are to make up the total price for the entire work, exclusive of those things which are to be done or furnished by the City, finished and complete in every particular, according to the Plans and Specifications appertaining to such work, which have been approved by the City Council and are now on file in the office of the City Engineer.

Where Proposals are solicited on the basis of unit prices for certain construction units, which are clearly set forth in the Form of Proposal, the Bidder shall state a unit price for each and every item listed in the Proposal and such prices shall be extended and totaled. If during the review of the Proposals, the City finds any errors in any extension or total, the City will make the necessary corrections and award the Contract on the basis of such corrections, since the unit prices shall govern. Any proposal which does not contain a unit price for each item listed will be deemed incomplete and will not be considered in the award of the Contract.

The unit price for each of the several items in the Proposal shall be such that the whole of the unit prices will represent a balanced bid. Any Proposal, in which the unit prices bid for any of the several items are deemed by the City to be manifestly unbalanced, will be subject to instant rejection.

B. STATEMENT OF QUANTITIES

The quantities indicated in the proposal show the Engineer's estimate of the construction quantities involved in the job, and bids will be computed, tested, and compared by the quantities given in the proposal. Although estimated carefully and with as much accuracy as is practicable beforehand, these quantities are not to be taken as defining or limiting the amount of work to be done under the Contract, but rather as information furnished to bidders concerning the approximate extent of the several items and as a basis for comparing bids.

The City may increase or decrease the original contract price without renegotiation of the Unit Prices.

C. MATERIALS TO BE FURNISHED BY THE CITY

The City will furnish to the Contractor, delivered at the site: NONE. The Contractor will receive and be responsible for all these materials from the time of their delivery to him until the time when they are received back by the City as part of the completed and accepted structure.

D. EXTRA WORK

All extra work that may be required of the Contractor will be estimated and paid for under provisions of the General Conditions, contained within this document, which govern such work.

E. ALTERNATES

When the Proposal so provides, a price shall be stated for each listed alternate. Unsolicited alternates are not to be submitted and, if so, will not be considered in the award of the Contract and may cause the entire bid to be rejected.

Selection of whether to award the Contract on the basis of the Base Bid or utilizing one or more of the Alternates will be made on the basis of value engineering and the City's need to keep project costs within the project budget. The City reserves full right to make this selection. After making such selection, the award shall be made on the basis of the lowest responsive bid utilizing the Alternates selected, and evaluated in accordance with the provisions of the Purchasing Ordinance of the City, in accordance with Article 15 of the Instructions to Bidders.

F. LEGAL CONDITIONS

All applicable laws, ordinances, and the rules and regulations of all authorities having jurisdiction over construction of the Project shall apply to the contract throughout.

G. PERMITS AND LICENSES

Permits and licenses of a temporary nature necessary for the prosecution of the WORK shall be secured and paid for by the CONTRACTOR unless otherwise stated in the SUPPLEMENTAL GENERAL CONDITIONS.

H. UTILITIES

Unless otherwise provided in these Specifications, the Contractor shall make his own arrangements for electricity, gas, water and sewer services for use during the construction of the work and shall pay for all connections, extensions, and services.

6. FORM OF PROPOSALS (Pages 13 through 18a)

All proposals must be made in the form attached hereto. Additional copies of this proposal form for the bidder's files may be obtained on request at the office of the City of Pontiac Department of Public Works.

All prices stated in the Proposal must be plainly expressed in figures only, and in the proper space or spaces provided. Prices shall be filled in, in ink or typewritten. Any corrections shall be initialed by the Bidder.

All information called for on the Proposal must be furnished to enable a fair comparison of the bids to be made. (Also see Instructions to Bidders, Section 10.)

The place of residence and phone number of each bidder, or the official address and phone number in the case of a firm or company, with County and State, must be given with the signature.

When bidder's drawings and/or specifications are required to be submitted, they shall be in sufficient detail to fully and distinctly show and describe the equipment which the bidder proposes to furnish, including the kind and quality of the material and workmanship that will be used in the various parts. If any general drawings, specifications, catalogs or any other literature are submitted which contain information or data not pertaining to the particular equipment proposed to be furnished, appropriate notations to that effect must be made.

Any stipulation or qualification contrary to the Contract requirements made by the bidder in or accompanying his proposal as a condition for the acceptance of the Contract will not be considered in the award of the Contract and may cause the rejection of the entire Proposal.

7. LEGAL STATUS OF BIDDER

The legal status of the bidder, that is, as a corporation, a partnership, or an individual, must be stated in the proposal. A corporation bidder must name the state in which its articles of incorporation are held, and must give the title of the official having authority under the by-laws to sign contracts. A partnership bidder must give the full names and addresses of all partners.

8. AGENCY

Anyone signing a proposal as agent of another or others must submit with the proposal legal evidence of his or her authority to do so.

9. BID DEPOSIT

When the Advertisement states that security is required with the Proposal to ensure the acceptance and execution of the Contract and Bonds, no bid will be considered complete unless so guaranteed.

Each proposal must be accompanied by a certified check of guaranty or a bid bond in an amount not less than five percent (5%) of the total price, drawn upon a solvent bank to the order of the City Treasurer of the City of Pontiac, or if a bond, executed by a surety company

acceptable to the City, as a guarantee of good faith on the part of the bidder and subject to the conditions stipulated in the proposal form.

A single certified check or guaranty (bidder's) bond may serve to cover two or more alternative proposals when such alternative proposals are submitted by the same bidder.

10. INTENTIONALLY LEFT BLANK

11. STATEMENT OF BIDDER'S QUALIFICATIONS

It is the intention of the City to award the Contract for this job to a Contractor whose construction skill and financial resources are fully equal to the task of prosecuting the work in a satisfactory manner and of bringing it to completion within the time limit specified. With this end in view, the Form of Proposal calls for a statement of bidder's experience and ability in this particular class of work, and for references concerning his/her business standing and capacity. Contractor shall list the names, addresses and phone numbers of references. The mere ability to offer bonds will not be taken as sufficient evidence of responsibility on the part of the bidder. If Contract is awarded to a foreign company, a certificate of authority to do business in this State must accompany the executed Contract.

The low BIDDER shall supply the names, addresses and phone numbers of major material SUPPLIERS and SUBCONTRACTORS when requested to do so by the CITY.

12. PAYMENTS

Partial payments will be made to the Contractor during the satisfactory progress of the work, calculated at the rate of ninety percent (90%) of the dollar amount of the work completed, until fifty percent (50%) of the established contract amount is in place. After fifty percent (50%) of the work is in place, additional retainage shall not be withheld unless the Contractor's progress is unsatisfactory, all in accordance with Article 13 of the General Conditions hereof and Act 524 of 1980.

13. TIME OF COMPLETION

This work to be done under the proposed Contract is to begin on or before the date stipulated in the Notice to Proceed and must be completed within **120 calendar days**, unless the date for completion is extended by the Contract Documents. Time shall be considered to be of the essence of this Contract.

14. RIGHT TO ACCEPT, TO REJECT, AND TO WAIVE DEFECTS

The City reserves the right to accept any proposal, to reject any or all proposals; and to waive any defect or irregularity in any proposal if it appears advantageous to the City to do so. In particular, any alteration, erasure, or interlineation in the Form of Contract in the Specifications which are attached hereto and made a part, specifically, of these Instructions, or of the Form of Proposal, shall render the accompanying proposal irregular and subject to rejection by the City. In case any explanations, additions or alterations are to be offered, they shall be indicated on separate sheets attached to the proposal and referred to therein. Proposals which are clearly unbalanced will also be considered as irregular, and will be subject to instant rejection by the City.

15. AWARD OF CONTRACT

The Contract will be awarded to the qualified Bidder submitting the lowest responsive Bid complying with the conditions of the Invitation for Bids. The Bidder's qualification and responsiveness shall be determined by the City of Pontiac. The Bidder to whom the award is made will be notified at the earliest possible date. The City reserves the right to reject all bids and not award the Contract, at its sole discretion.

16. OBLIGATION TO EXECUTE CONTRACT

The Bidder whose proposal is accepted will be required to execute the Contract, in the form attached hereto, and to furnish sureties as hereafter specified, within ten days (Sundays and legal holidays excepted), after receiving notice of acceptance of bid and preparation Contract forms is completed, and in case of the successful bidder's refusal or failure to do so, shall be considered to have abandoned all their rights and interests in the award, and their certified check or guaranty (bidder's) bond may be declared to be forfeited to the City as liquidated damages and not a penalty, and the Contract may be awarded to another.

17. BONDS

The successful bidder will be required to execute surety bonds, with sureties acceptable to the City. One such bond shall be a Performance Bond in the amount of 100 percent of the Contract Price on the form attached as pages 25 and 26 of the specifications. Another such bond shall be a Labor and Material Bond in the amount of 100 percent of the Contract Price on the form attached as pages 27 and 28 of the specifications. The Contractor shall also provide a Maintenance Bond in the amount of 100 percent of the Contract Price on the form attached as pages 29 and 30 of the specifications.

18. INDEMNIFICATION AND INSURANCE

To the fullest extent permitted by law, the successful bidder agrees to defend, pay on behalf of, indemnify, and hold harmless the CITY OF PONTIAC, its elected and appointed officials, employees, consultants, and volunteers and others working on behalf of the CITY OF PONTIAC, against any and all claims, demands, suits, or loss, including all costs connected therewith, and for any damages which may be asserted, claimed or recovered against or from the CITY OF PONTIAC, its elected and appointed officials, employees, consultants, volunteers or others working on behalf of the CITY OF PONTIAC, by reason of personal injury, including bodily injury and death, and/or property damage, including loss of use thereof, which arises out of or is in any way connected or associated with this contract.

The successful bidder shall purchase and maintain in a company or companies licensed to do business in the State of Michigan, such insurance as will protect him from claims set forth below which may arise out of or result from the contractor's operations under the contract, whether such operations be by himself or any subcontractor or by anyone directly or indirectly employed by any of them, or by anyone whose acts are associated with the project by any of them, may be liable.

a. Workers Compensation Insurance: The contractor shall procure and maintain during the life of the contract, Workers Compensation Insurance, including Employer's Liability Coverage, in accordance with all applicable statutes of the State of Michigan.

b. Commercial General Liability Insurance: The contractor shall procure and maintain during the life of this contract, Commercial General Liability Insurance on an "Occurrence Basis" with the limits of liability not less than **\$2,000,000**, per occurrence and/or aggregate combined single limit, Personal Injury, Bodily Injury and Property Damage. Coverage shall include the following extensions: (1) Contractual Liability; (2) Products and Completed Operations; (3) Independent Contractors Coverage; (4) Broad Form General Liability Extensions or equivalent; and (5) Deletion of all Explosion, Collapse and Underground (XCU) Exclusions, if applicable.

c. Motor Vehicle Liability: The contractor shall procure and maintain during the life of the contract, Motor Vehicles Liability Insurance, including Michigan No-Fault coverage, with limits of not less than **\$2,000,000**, per occurrence combined single limit Bodily Injury and Property Damage. Coverage shall include all owned vehicles, all non-owned vehicles and all hired vehicles.

d. Additional Insured: Commercial General Liability and Motor Vehicle Liability Insurance, as described above, shall include an endorsement stating the following shall be **"Additional Insured"**. *"THE CITY OF PONTIAC, INCLUDING ALL ELECTED AND APPOINTED OFFICIALS, ALL EMPLOYEES AND VOLUNTEERS, ALL BOARDS, COMMISSIONS AND/OR AUTHORITIES AND THEIR BOARD MEMBERS, EMPLOYEES AND VOLUNTEERS" AND NOWAK & FRAUS ENGINEERS, the project consultant.* (This coverage shall be primary to the Additional Insured, and not contributing with any other insurance or similar protection available to the Additional Insureds, whether said other available coverage be primary, contributing or excess.)

e. Cancellation Notice: Workers Compensation Insurance, Commercial General Liability Insurance, and Motor Vehicle Insurance, as described above, shall include an endorsement stating the following: *"IT IS UNDERSTOOD AND AGREED THAT **THIRTY (30) DAYS ADVANCE WRITTEN NOTICE OF CANCELLATION, NON-RENEWAL, REDUCTION AND/OR MATERIAL CHANGE SHALL BE SENT TO: CITY OF PONTIAC, ENGINEERING DIVISION, 47450 WOODWARD AVE., PONTIAC, MICHIGAN, 48342**"*.

f. Owner's and Contractor's Protective Liability: The contractor shall procure and maintain during the life of this contract, a separate Owner's and Contractor's Protective Liability insurance coverage of not less than **\$2,000,000**, per occurrence and/or aggregate, combined single limit, Personal Liability, Bodily Injury, and Property Damage. The City of Pontiac shall be "Named Insured" on said coverage. Thirty (30) days Notice of Cancellation shall apply to this policy.

The successful bidder shall not commence work until he has obtained the insurance required under this section, nor shall the successful bidder permit any subcontractor to commence work on his subcontract until the insurance required of the subcontractor has been obtained.

Certificates of Insurance, along with copies of original policies where applicable, acceptable to the City, shall be filed with the City of Pontiac, Engineering Division, ten (10) days prior to commencement of the contract. A sample certificate is included on page **12** for reference.

19. CITY INCOME TAX

a. Contractor agrees to contact City of Pontiac Income Tax Division, Audit and Compliance Section, 47450 Woodward Avenue, Pontiac, Michigan, 48342, telephone (248) 758-3236, to establish reporting and withholding obligations under the City of Pontiac Income Tax Ordinance. Contractor will require the same of all subcontractors employing labor under this contract.

b. Normally, the Contractor will be required to withhold City of Pontiac income tax if either of the following applies:

- (1) Performance under this contract (together with any other contracts in the City during the calendar year) will last 13 weeks or more.

(2) Contractor employs one or more Pontiac residents for the performance of this contract.

c. Contractor agrees to pay any personal property taxes required by the City Assessor.

20. PRE-BID MEETING

An online pre-bid meeting will be held on **Tuesday, June 1, 2021 at 10:00 a.m. local time.** Login information to be provided.

21. CITY OF PONTIAC PURCHASING ORDINANCE (Chapter 2, Article VI, Division 2) Municipal Code, City of Pontiac, Michigan, adopted March 21, 1996 and effective March 31, 1996.

Bidders are advised of the following provisions of the Purchasing Ordinance:

a. Intentionally Left Blank

b. CONTRACTOR OR VENDOR IN DEFAULT OR INDEBTED TO THE CITY

No bid shall be accepted from or contract awarded to any contractor or vendor who is in arrears to the City upon debt or contract including payments of real property taxes or an income tax obligation of any kind, or who is in default as to security or otherwise upon an obligation to the City.

c. VIOLATIONS - MISREPRESENTATION

Any material misrepresentation to the City of Pontiac by a bidder or prospective bidder, contractor or vendor in any documentation or paperwork submitted in a bid or proposal or otherwise in connection with an attempt to obtain a contract or engage in a business transaction shall be a violation, and may be considered sufficient basis to disqualify the contractor or vendor from eligibility for the award of a City contract.

22. NON-DISCRIMINATION PROVISION

Pursuant to the requirements of 1976, P.A. 453 (Michigan Civil Rights Act) and 1976, P.A. 220 (Michigan Handicapped Rights Act), the bidder and any subcontractors agree not to discriminate against any employee or applicant for employment with respect to hire, tenure, terms, conditions, or privileges of employment or a matter directly or indirectly related to employment, because of race, color, religion, national origin, age, sex, height, weight, marital status, or due to a handicap that is unrelated to the person's ability to perform the duties of a particular job or position. The Bidder must include this provision in any subcontracts associated with the project work.

CONTRACTOR: _____

FORM OF PROPOSAL

Date: _____

To the Honorable Mayor / City Council
City of Pontiac, Michigan

Ladies and Gentlemen:

Having carefully examined the site of the proposed work, and being fully informed in regard to the conditions to be met in the prosecution and completion of the work, and having read and examined the Instructions to Bidders, Agreement, Bonds, General Conditions, Plans and Specifications pertaining to this work, and agreeing to be bound accordingly, the undersigned proposes to furnish all the materials, labor, tools, power, transportation and construction equipment necessary for the satisfactory and complete construction of the **2021 CDBG SIDEWALK IMPROVEMENT PROGRAM** in full accordance with and conformity to the specifications for this work now on file in the office of the City Engineer at and for the following named prices, to wit:

| Item No. | Description | Quantity | Unit | Unit Price | Bid Amount |
|--------------------------|------------------------|----------|------|------------|------------|
| 1. | Sidewalk, Rem | 7,615 | SY | \$ _____ | \$ _____ |
| 2. | Sidewalk, Conc, 4 Inch | 50,350 | SF | \$ _____ | \$ _____ |
| 3. | Sidewalk, Conc, 6 Inch | 13,615 | SF | \$ _____ | \$ _____ |
| 4. | Sidewalk, Conc, 8 Inch | 490 | SF | \$ _____ | \$ _____ |
| 5. | Hand Patching | 25 | Ton | \$ _____ | \$ _____ |
| 6. | Root Removal | 525 | Each | \$ _____ | \$ _____ |
| 7. | Stump Removal | 25 | Each | \$ _____ | \$ _____ |
| 8. | Timber Wall | 200 | LF | \$ _____ | \$ _____ |
| TOTAL BID AMOUNT: | | | | | \$ _____ |

The City of Pontiac reserves the right to increase or decrease any quantity or delete any item(s) of work as it deems in the best interest of the City, there will be no adjustments to unit prices in the event of increase, decrease or deletions.

Contractor acknowledges receipt of the following Addendum(s):

Addendum No.: _____ Dated: _____

Addendum No.: _____ Dated: _____

The Contractor acknowledges that he has not received nor relied upon any representations or warranties of any nature whatsoever from the City of Pontiac, its officers, employees or agents and that if he is awarded this contract, he shall enter into this Contract solely as the result of his own independent business judgment.

The undersigned acknowledges that he has made his own independent investigation and has satisfied himself as to the conditions of the work, including soil and subsurface conditions.

The undersigned agrees that, in case any additions, deductions or deletions in the amount of work contemplated are made, the above named unit prices for the various classes of work shall be used to allow for such additions, deductions or deletions.

The undersigned hereby agrees that if this Proposal shall be accepted by the said City, he will, within ten days after receiving notice of such acceptance and delivery of Contract forms thereof at the address given below (Sundays and legal holidays excepted), enter into contract, in the attached form, to construct the said work according to said plans and specifications and to furnish therefor all necessary equipment, tools and building appliances, materials, labor, power and transportation as aforesaid at and for the prices named in the foregoing paragraph; to furnish to the said City and to the State of Michigan such sureties for the faithful performance of such Contract and for the payment of all materials used therein and for all labor expended thereon as shall be approved and accepted by the said City; and to furnish to the said City of Pontiac a Maintenance Bond.

The undersigned attaches hereto a (certified check), (bidder's bond), in the sum of:

Dollars (\$ _____)

as required in the Instructions to Bidders. And the undersigned hereby agrees that, in case he shall fail to fulfill his obligations under the foregoing proposal and agreement, the said City may, at its option, determine that the undersigned has abandoned his rights and interests in such contract and that the certified check or bidder's bond accompanying this proposal has been forfeited to the said City as liquidated damages and not as a penalty; but, otherwise the said certified check or bidder's bond shall be returned to the undersigned upon the execution of such contract and the acceptance of Bonds.

The undersigned states that he currently owns or intends to rent the following equipment that will be used in work covered by this proposal:

List of Equipment Owned

List of Intended Rental Equipment

The undersigned states that he has done work similar in character to that covered by this proposal at the following named times and places, to wit:

The undersigned refers the said City to the following named parties for information concerning his experience, skill and business standing:

NAME, ADDRESS AND PHONE NUMBER:

Dated and signed at _____, MI on _____
(City) (Date)

Name of Bidder: _____

Address of Bidder: _____

By: _____

Title: _____

Telephone#: _____ Fax#: _____

Federal Tax I.D. Number (_____)

CERTIFICATIONS

IF A CORPORATION

I, _____, certify that I am the _____ of the corporation named as Contractor herein; that _____, who signed this Agreement on behalf of the Contractor, was then _____ of said corporation; that said Agreement was duly signed for and in behalf of said corporation by authority of its governing body, and is within the scope of its corporate powers.

Corporate Seal

Signature

IF A PARTNERSHIP

I, _____, certify that I am a partner in the partnership named as Contractor herein, and that I have authority to sign for and on behalf of this partnership consisting of the following partners:

NAME AND ADDRESS:

Signature

IF A SOLE PROPRIETORSHIP

I, _____, certify that I am the sole owner and proprietor.

Signature

THIS PAGE IS INTENTIONALLY LEFT BLANK

THIS PAGE IS INTENTIONALLY LEFT BLANK

THIS PAGE IS INTENTIONALLY LEFT BLANK

BID BOND

KNOW ALL MEN BY THESE PRESENTS, that we, the undersigned, _____
_____ as Principal,
and _____ as Surety, are
hereby held and firmly bound unto the City of Pontiac, Michigan, as OWNER in the
penal sum of:

_____ Dollars (\$ _____)

for the payment of which, well and truly to be made, we hereby jointly and severally bind
ourselves, successors and assigns. Signed, this _____ day of _____, 20 _____.

The Condition of the above obligation is such that whereas the Principal has
submitted to the City of Pontiac, Michigan, a certain BID, attached hereto and hereby
made a part hereof to enter into a contract in writing, for the

NOW, THEREFORE,

- (a) If said BID shall be rejected, or
- (b) If said BID shall be accepted and the Principal shall execute and deliver a contract in the Form of Contract attached hereto (properly completed in accordance with said BID) and shall furnish a BOND for his faithful performance of said contract, and for the payment of all persons performing labor or furnishing materials in connection therewith, and shall in all respects perform the agreement created by the acceptance of said BID, then this obligation shall be void, otherwise the same shall remain in force and effect; it being expressly understood and agreed that the liability of the Surety for any and all claims hereunder shall, in no event, exceed the penal amount of this obligation as herein stated.

The Surety, for value received, hereby stipulates and agrees that the obligations of said Surety and its BOND shall be in no way impaired or affected by any extension of the time within which the OWNER may accept such BID; and said Surety does hereby waive notice of any such extension.

IN WITNESS WHEREOF, the Principal and the Surety have hereunto set their hands and seals, and such of them as are corporations have caused their corporate seals to be hereto affixed and these presents to be signed by their proper officers, the day and year first set forth above.

Principal (L.S)

Surety (L.S.)

By: _____

IMPORTANT - Surety companies executing BONDS must appear on the Treasury Department's most current list (Circular 540 as amended) and be authorized to transact business in the State of Michigan.

AGREEMENT

THIS AGREEMENT, made this _____ day of _____, 20__, by and between the City of Pontiac, Oakland County, Michigan, party of the first part, hereafter called the City, and _____, Michigan, party of the second part, hereinafter called the Contractor:

WITNESSETH: That for and in consideration of the payments and agreements hereinafter mentioned:

1. The CONTRACTOR shall commence and complete the construction of:

2021 CDBG SIDEWALK IMPROVEMENT PROGRAM

in full conformance with the Contract Documents as enumerated in Article 6 of this Agreement.

2. The CONTRACTOR shall furnish all of the material, supplies, tools, equipment, labor and other services necessary for the construction and completion of the PROJECT described herein, excepting those things which are specifically stipulated in the contract documents to be furnished or done by the City.

3. The CONTRACTOR shall commence the work required by the CONTRACT DOCUMENTS on or before the date stipulated in the NOTICE TO PROCEED and will complete the same within **120 calendar days**, unless the date for completion is extended otherwise by the CONTRACT DOCUMENTS. Time shall be considered to be of the essence of this Contract.

4. The CONTRACTOR agrees to perform all of the WORK described in the CONTRACT DOCUMENTS and comply with the terms therein for the contract price of:

unless the contract price is duly changed by the contract documents.

5. The CITY shall pay to the CONTRACTOR in the manner and at such times as set forth in the General Conditions such amounts as required by the CONTRACT DOCUMENTS.

6. The term "CONTRACT DOCUMENTS" means and includes the following:

- A. AGREEMENT
- B. BID BOND
- C. PERFORMANCE BOND
- D. LABOR AND MATERIAL BOND

- E. MAINTENANCE BOND
- F. CHANGE ORDER (Pursuant to General Conditions, Section 9)
- G. ADDENDA:
 - No. _____, dated _____, 20____ .
 - No. _____, dated _____, 20____ .
 - No. _____, dated _____, 20____ .
- H. ADVERTISEMENT
- I. INSTRUCTIONS TO BIDDERS
- J. BIDDER'S PROPOSAL
- K. GENERAL CONDITIONS (Incl. SUPPLEMENTAL GENERAL CONDITIONS and SPECIAL CONDITIONS (if any))
- L. SPECIFICATIONS (Incl. SUPPLEMENTAL SPECIFICATIONS and SPECIAL PROVISIONS (if any))
- M. PLANS (As listed in Schedule of Drawings)
- N. NOTICE OF AWARD
- O. NOTICE TO PROCEED

This agreement, together with other documents enumerated in this ARTICLE 6, which said other documents are as fully a part of the Contract as if hereto attached or herein repeated, forms the Contract between the parties hereto. In the event that any provision in any component part of this Contract conflicts with any provision of any other component part, the provision of the component part first enumerated in this ARTICLE 6 shall govern, except as otherwise specifically stated.

7. This Agreement shall be binding upon all parties hereto and their respective heirs, executors, administrators, successors, and assigns.

IN WITNESS WHEREOF, the parties hereto have executed, or caused to be executed by their duly authorized officials, this Agreement in four (4) copies, each of which shall be deemed an original, on the date first above written.

**CONTRACT AGREEMENT BETWEEN THE CITY OF PONTIAC
AND CONTRACTOR**

2021 CDBG SIDWALK IMPROVEMENT PROGRAM

CONTRACTOR: _____

In witness whereof, the parties have executed this agreement the day and year last written below.

WITNESSES:

1) _____ By: _____
2) _____ Its: _____

CITY OF PONTIAC

WITNESSES:

DEPARTMENT OF PUBLIC WORKS

1) _____ By: _____ Date
Dan Ringo
2) _____ Its: Acting Director

WITNESSES:

DEPARTMENT OF FINANCE

1) _____ By: _____ Date
Darin Carrington
2) _____ Its: Director

WITNESSES:

OFFICE OF THE MAYOR

1) _____ By: _____ Date
Deidre Waterman
2) _____ Its: Mayor

WITNESSES:

1) _____
2) _____

Approved as to form:

By: _____
_____, City Attorney

CERTIFICATIONS

IF A CORPORATION

I, _____, certify that I am the _____ of the corporation named as Contractor herein; that _____, who signed this Agreement on behalf of the Contractor, was then _____ of said corporation; that said Agreement was duly signed for and in behalf of said corporation by authority of its governing body, and is within the scope of its corporate powers.*

Corporate Seal

Signature

* Attach copy of corporate resolution verifying authorization of individuals named above.

IF A PARTNERSHIP

I, _____, certify that I am a partner in the partnership named as Contractor herein, and that I have authority to sign for and on behalf of this partnership consisting of the following partners:

NAME AND ADDRESS:

Signature

IF A SOLE PROPRIETORSHIP

I, _____, certify that I am the sole owner and proprietor.

Signature

BOND FOR FAITHFUL PERFORMANCE

KNOW ALL MEN BY THESE PRESENTS, That _____

_____ as principal, and

_____, as surety, are held and

firmly bound unto the City of Pontiac, Michigan, a Municipal Corporation, in the sum of:

good and lawful money of the United States of America, to be paid to said City of Pontiac, its legal representatives and assigns, for which payment well and truly to be made, we bind ourselves, our heirs, executors, administrators, successors, and assigns, and each and every one of them, jointly and severally, firmly by these presents.

Sealed with our Seals and dated this _____ day of _____ A.D. 20 _____.

WHEREAS, the above named principal has entered into a certain written contract with the City of Pontiac, dated this _____ day of _____ A.D. 20 _____, wherein the said principal covenanted and agreed as follows, to-wit:

TO COMMENCE AND COMPLETE the:

2021 CDBG SIDEWALK IMPROVEMENT PROGRAM

NOW, THEREFORE, THE CONDITION OF THIS OBLIGATION IS such that if the above named principal or their legal representatives or successors, shall in all things well and truly keep and perform the covenants, conditions, and agreements in the manner and form and at the time agreed upon to be kept and performed as provided by said contract, and plans, drawings, and specifications, referred to in said contract, and as may be required by the changes, alterations, and modifications thereof, as provided in said contract, then the above obligation shall be void; otherwise to remain in full force and effect.

This bond is given upon the express condition that any changes, alterations, or modifications that may be hereafter ordered or made in the construction and complete installation of the work herein referred to, or the placing of an inspector or superintendent thereon by the City of Pontiac shall not operate to discharge or release the surety or sureties thereon.

IN WITNESS WHEREOF, the parties hereto have caused this instrument to be executed by their respective authorized officers this _____ day of _____ A.D. 20 _____.

Signed, Sealed and Delivered in the Presence of:

| | |
|-------|--------------|
| _____ | _____ (L.S.) |
| _____ | _____ (L.S.) |
| _____ | _____ (L.S.) |

**LABOR AND MATERIAL BOND TO THE
CITY OF PONTIAC, MICHIGAN**

KNOW ALL MEN BY THESE PRESENTS, That _____
_____ as principal, and _____

_____, as surety, are
held and firm bound unto the City of Pontiac, Michigan, a Municipal Corporation, in the
sum of:

_____ good and lawful money of the United States of America, pursuant to Michigan State
Public Act 213 of 1963, to be paid to the City of Pontiac, Michigan, for the use and
benefit of all subcontractors, and persons, firms and corporations who shall furnish
materials, supplies and perform labor entering into the work of:

2021 CBDG SIDEWALK IMPROVEMENT PROGRAM

_____ for which payment well and truly to be made, we bind ourselves, our heirs, executors,
administrators, successors and assigns, and each and every one of them jointly and
severally, firmly by these presents.

Sealed with our Seals and dated this _____ day of _____ A.D. 20 _____.

WHEREAS, the above named principal has entered into a certain written contract
with the City of Pontiac, dated this _____ day of _____ A.D. 20 _____,
wherein the said principal covenanted and agreed as follows, to wit:

TO COMMENCE AND COMPLETE the: _____

Project Name 2021 CBDG SIDEWALK IMPROVEMENT PROGRAM

NOW, THEREFORE, THE CONDITION OF THIS OBLIGATION IS SUCH, that if the above named principal, legal representatives, or successors shall pay or cause to be paid to all subcontractors, persons, firms, and corporation, as the same may become due and payable, all indebtedness which may arise from said principal to a subcontractor or party performing labor or furnishing materials and supplies, or any subcontractor to any person, firm or corporation on account of any labor performed or materials and supplies furnished in connection with the contract, construction and work herein referred to, then this obligation shall be void; otherwise to remain in full force and effect.

This bond is given upon the express condition that any changes, alterations, or modifications that may be hereafter ordered or made in the construction and complete installation of the work herein referred to, or the placing of an inspector or superintendent thereon by the City of Pontiac shall not operate to discharge or release the surety or sureties thereon.

IN WITNESS WHEREOF, the parties hereto have caused this instrument to be executed by their respective authorized officers this _____ day of _____ A.D. 20 _____.

Signed, Sealed and Delivered in the Presence of:

| | |
|-------|--------------|
| _____ | _____ (L.S.) |
| _____ | _____ (L.S.) |
| _____ | _____ (L.S.) |

MAINTENANCE BOND

KNOW ALL MEN BY THESE PRESENTS, That _____

_____ as principal, and _____

_____, as surety, are held

and firm bound unto the City of Pontiac, Michigan, a Municipal Corporation, in the sum of:

good and lawful money of the United States of America, pursuant to Michigan State Public Act 213 of 1963, to be paid to the City of Pontiac, Michigan, for the use and benefit of all subcontractors, and persons, firms and corporations who shall furnish materials, supplies and perform labor entering into the work of:

2021 CDBG SIDEWALK IMPROVEMENT PROGRAM

for which payment well and truly to be made, we bind ourselves, our heirs, executors, administrators, successors and assigns, and each and every one of them jointly and severally, firmly by these presents.

Sealed with our Seals and dated this _____ day of _____ A.D. 20 _____.

WHEREAS, the above named principal has entered into a certain written contract with the City of Pontiac, dated this _____ day of _____ A.D. 20 _____, wherein the said principal covenanted and agreed as follows, to wit:

TO COMMENCE AND COMPLETE construction of: _____

2021 CDBG SIDEWALK IMPROVEMENT PROGRAM

NOW, THEREFORE, THE CONDITION OF THIS OBLIGATION IS SUCH, that by and under said contract, the above named principal has agreed with the City of Pontiac that for a period of ONE year(s) from the date of payment of Final Estimate, to keep in good order and repair all the work, done under said contract, excepting only such part or parts of said work as may have been disturbed without the consent or approval of the principal after the final acceptance of the work, and that whenever directed so to do by the City Engineer of the City of Pontiac by notice served in writing, either personally or by mail, on the principal at:

_____ or _____

legal representative, or successors, or on the surety at: _____

_____ WILL PROCEED at once to make such

repairs as directed by said City Engineer; and in case of failure so to do within one week from the date of service of such notice, or within reasonable time not less than one week, as shall be fixed in said notice, then the City of Pontiac shall have the right to purchase such materials and employ such labor and equipment as may be necessary for the purpose, and to undertake, do and make such repairs, and charge the expense thereof to, and receive same from said principal or surety. If any repair is necessary to be made at once to protect life and property, then and in that case, the City may take immediate steps to repair or barricade such defects without notice to the contractor. In such accounting the City shall not be held to obtain the lowest figures for the doing of the work or any part thereof, but all sums actually paid therefore shall be charged to the principal or surety. In this connection the judgment of the City Engineer is final and conclusive. If the said principal for a period of ONE year(s) from the date of payment of Final Estimate, shall keep said work so constructed under said contract in good order and repair, excepting only such part or parts of said work which may have been disturbed without the consent or approval of said principal after the final acceptance of the same, and shall, whenever notice is given as hereinbefore specified, at once proceed to make repair as in said notice directed, or shall reimburse said City of Pontiac for any expense incurred by making such repairs, should the principal or their surety do so as hereinbefore specified, then the above obligation shall be void, otherwise to remain in full force and effect.

IN WITNESS WHEREOF, the parties hereto have caused this instrument to be executed by their respective authorized officers this _____ day of _____ A.D. 20 _____.

Signed, Sealed and Delivered in the Presence of:

_____ (L.S.)

_____ (L.S.)

_____ (L.S.)

GENERAL CONDITIONS

The following general conditions are agreed to as defining certain relationships which shall be taken to exist between the parties hereto and as setting forth certain conditions under which the Contract is to be fulfilled.

INDEX

Article

1. Definitions
2. Plans and Specifications
3. Shop Drawings
4. Materials and Workmanship
5. Superintendence by Contractor
6. Engineering Supervision
7. City's Right to Complete, Suspension or Termination
8. Assignment of Contract
9. Extra Work and Modification
10. Disputed Claims for Extra Compensation
11. Extension of Time
12. Liquidated Damages
13. Payment to the Contractor
14. Warranty Maintenance
15. Michigan Non-Discrimination Statute
16. Labor Laws and Ordinances
17. Patents and Patent Rights
18. Work within Railroad, Private, State or County Rights-of-way
19. Protection and Safety
20. Cleaning Up
21. Progress Schedule

GENERAL CONDITIONS

Article 1 - DEFINITIONS

- 1.1 Wherever used in the CONTRACT DOCUMENTS, the following terms shall have the meanings indicated which shall be applicable to both the singular and plural thereof:
- 1.2 ADDENDA - Written or graphic instruments issued prior to the execution of the Agreement which modify or interpret the CONTRACT DOCUMENTS by additions, deletions, clarifications or corrections.
- 1.3 BID - The offer or proposal of the BIDDER submitted on the prescribed form setting forth the prices for the WORK to be performed. (See 1.8)
- 1.4 BIDDER - Any person, firm or corporation submitting a BID for the WORK.
- 1.5 BONDS - Bid, Performance, Labor and Material, and Maintenance Bonds and other instruments of security, furnished by the CONTRACTOR and his surety in accordance with the CONTRACT DOCUMENTS.
- 1.6 CHANGE ORDER - A written order to the CONTRACTOR authorizing an addition, deletion or revision in the WORK within the general scope of the CONTRACT DOCUMENTS, or authorizing an adjustment in the CONTRACT PRICE or CONTRACT TIME.
- 1.7 CITY - The City of Pontiac, Michigan, or its properly authorized representatives; and whenever the term "City Council", "Mayor", "City Clerk", "Director of Finance", "City Engineer", or "Engineer", is used, it shall be understood to mean the Council, Mayor, Clerk, Director of Finance, or Engineer of the said City.
- 1.8 LEFT BLANK INTENTIONALLY
- 1.9 CONTRACT DOCUMENTS - The Contract, including ADVERTISEMENT, INSTRUCTIONS TO BIDDERS, FORM OF PROPOSAL, BID BOND, AGREEMENT, LABOR & MATERIAL BOND, PERFORMANCE BOND, MAINTENANCE BOND, GENERAL CONDITIONS, SUPPLEMENTAL GENERAL CONDITIONS, NOTICE OF AWARD, NOTICE TO PROCEED, CHANGE ORDER, PLANS, SPECIFICATIONS, ADDENDA, and any other documents specifically set forth in the Agreement.
- 1.10 CONTRACT PRICE - The total monies payable to the CONTRACTOR under the terms and conditions of the CONTRACT DOCUMENTS.
- 1.11 CONTRACT TIME - The number of calendar days stated in the CONTRACT DOCUMENTS for the completion of the WORK on each street; or the number of calendar days from the date established in the NOTICE TO PROCEED to the DATE stated in the

CONTRACT DOCUMENTS for the completion of all of the WORK of the TOTAL CONTRACT; or both.

- 1.12 CONTRACTOR - The person, firm or corporation with whom the CITY has executed the Agreement, or its legal representatives.
- 1.13 ENGINEER - The City Engineer and/or the person, firm or corporation named as such in the CONTRACT DOCUMENTS.
- 1.14 FIELD ORDER - A written order effecting a change in the WORK not involving an adjustment in the CONTRACT PRICE or an extension of the CONTRACT TIME, issued by the ENGINEER to the CONTRACTOR during construction.
- 1.15 NOTICE OF AWARD - The written notice of the acceptance of the BID from the CITY to the successful BIDDER.
- 1.16 NOTICE TO PROCEED - Written communication issued by the CITY to the CONTRACTOR authorizing him to proceed with the WORK and establishing the date of commencement of the WORK.
- 1.17 OPEN TO TRAFFIC - That date as certified by the ENGINEER, when the WORK (PROJECT) or any section thereof is in a suitable condition for safe travel. The term "SUITABLE CONDITION FOR SAFE TRAVEL" shall be construed to mean that all work, INCLUDING the Leveling Course of Bituminous Material and all Concrete Work are complete. The PROJECT, or any portion thereof may be designated as "Accepted for Traffic" prior to completion of the whole project, and shall be opened to traffic as may be directed by the ENGINEER. In general, the term "OPEN TO TRAFFIC" shall be in accordance with Section 107.21 of the MDOT 2012 Standard Specifications for Construction.
- 1.18 **THIS SECTION IS LEFT INTENTIONALLY LEFT BLANK.**
- 1.19 PROJECT - The undertaking to be performed as provided in the CONTRACT DOCUMENTS.
- 1.20 RESIDENT PROJECT REPRESENTATIVE - The authorized representative of the CITY who is assigned to the PROJECT site or any part thereof.
- 1.21 SHOP DRAWINGS - All drawings, diagrams, illustrations, brochures, schedules and other

data which are prepared by the CONTRACTOR, a SUBCONTRACTOR, manufacturer, SUPPLIER or distributor, which illustrate how specific portions of the WORK shall be fabricated or installed.

- 1.22 SPECIFICATIONS - A part of the CONTRACT DOCUMENTS consisting of written descriptions of a technical nature of materials, equipment, construction systems, standards and workmanship (may include SUPPLEMENTAL SPECIFICATIONS AND/OR SPECIAL PROVISIONS).
- 1.23 SUBCONTRACTOR - An individual, firm or corporation having a direct contract with the CONTRACTOR or with any other SUBCONTRACTOR for the performance of a part of the WORK at the site.
- 1.24 SUPPLIER - Any person or organization who supplies materials or equipment for the WORK, including that fabricated to a special design, but who does not perform labor at the site.
- 1.25 WORK - All labor necessary to produce the construction required by the CONTRACT DOCUMENTS, and all materials and equipment incorporated or to be incorporated in the PROJECT.
- 1.26 WORK ORDER - A written order to the CONTRACTOR causing a change in WORK involving the authorization to undertake additional work at existing contract unit prices or at new contract unit prices for new items of work.
- 1.27 WRITTEN NOTICE - Any notice to any party of the Agreement relative to any part of this Agreement in writing and considered delivered and the service thereof completed, when posted by certified or registered mail to the said party at his last given address, or delivered in person to said party or his authorized representative on the WORK.

Article 2 - PLANS AND SPECIFICATIONS

The location of the structures and improvements which are to be built or made under this Contract, and the character, form and dimensions of their various parts, are shown in the accompanying drawings, specifications and details in the Contract Document entitled:

2021 CDBG SIDEWALK IMPROVEMENT PROGRAM

These drawings constitute the Plans according to which the work of this Contract is to be done. Additional drawings may be prepared by the City Engineer and supplied to the Contractor during the progress of the work, as he may deem to be necessary or expedient. All such additional drawings, made in elaboration or explanation of the original drawings, are to be considered as part and parcel of the Plans and shall be respected and followed as such by the Contractor.

The Plans are supplemented and explained by a set of technical specifications, which are appended hereto, and which describe and define the quality of materials and the character of workmanship which are to enter into the work of this Contract. These are the Specifications which are referred to in Article 1, and elsewhere in this Contract. Additional specifications in further elaboration or explanation of the work to be done may be prepared by the City Engineer and supplied to the Contractor during the progress of the work, as he may deem to be necessary or expedient. Such additional specifications are to be considered as part and parcel of the specifications under this Contract, and shall be respected and followed as such by the Contractor.

Both Plans and Specifications are considered as essential parts of this Contract, and are intended to be cooperative. They shall be construed as supplementary each to the other, and any work called for in the Plans and not particularly mentioned in the Specifications, or described in the Specifications and not specially shown on the Plans, is to be regarded as included under this Contract the same as if fully set forth in the Specifications and exhibited on the Plans. Wherever figures or definite dimensions are given on the Plans or in the Specifications, these shall have precedence over dimensions taken by scaling.

In case any inconsistency, omission, or conflict shall be discovered in the Specifications or Plans, or if in any place the meaning of either or both shall be obscure or uncertain or in dispute, the City Engineer shall decide as to the true intent and his decision shall be final and binding. Any such inconsistencies, omissions, or conflict noted should be called to the attention of the Engineer, and a decision on the same obtained in advance.

Article 3 - SHOP DRAWINGS

- 3.1 The CONTRACTOR shall provide SHOP DRAWINGS as may be necessary for the prosecution of the WORK as required by the CONTRACT DOCUMENTS. The ENGINEER shall promptly review all SHOP DRAWINGS. The ENGINEER's approval of any SHOP DRAWINGS shall not release the CONTRACTOR from responsibility for deviations from the CONTRACT DOCUMENTS. The approval of any SHOP DRAWING which substantially deviates from the requirement of the CONTRACT DOCUMENTS shall be evidenced by a CHANGE ORDER.
- 3.2 When submitted for the ENGINEER'S review, SHOP DRAWINGS shall bear the CONTRACTOR'S certification that he has reviewed, checked and approved the SHOP DRAWINGS and that they are in conformance with the requirements of the CONTRACT DOCUMENTS.
- 3.3 Portions of the WORK requiring a SHOP DRAWING or sample submission shall not begin until the SHOP DRAWING or submission has been approved by the ENGINEER. A copy of each approved SHOP DRAWING and each approved sample shall be kept in good order by the CONTRACTOR at the site and shall be available to the ENGINEER.

Article 4 - MATERIALS AND WORKMANSHIP

It is mutually understood that all materials and workmanship furnished under this Contract shall be of the highest quality, to the end that a good and substantial and workmanlike job may be produced. The Contractor shall bring only first class materials to the work, and he shall furnish suitable tools and equipment and shall employ competent labor to perform the work to be done. Any materials or labor or tools or equipment that shall not, in the judgment of the Engineer, be suitable or competent to produce the desired result, may be ordered from the work by the Engineer, and such materials or labor or tools or equipment shall be promptly substituted therefor by the Contractor as will meet with the approval of the Engineer. Wherever a brand or name is given, it is for the purpose of defining or establishing a type or quality of material only.

4.1 Defective Materials

Any materials or fabricated articles furnished by the Contractor to be used in this work which shall not, in the judgment of the Engineer, be equal to the requirements of the Plans and Specifications, may be rejected by the Engineer; and such rejected materials or articles shall not be used, but shall be immediately removed by the Contractor from the site of the work.

4.2 Stored Materials

Materials and equipment distributed, stored or placed upon or near the site of the work shall be at all times so disposed as not to interfere with work being prosecuted directly by the City or by other Contractors in the City's employ or with access thereto, and not to hinder any more than may be necessary the ordinary pedestrian and vehicular traffic of the streets.

4.3 Property Rights in Surplus Materials

All excess materials excavated during the progress of the work and not required for backfilling, all timber except tree stumps cut from the right-of-way, and all other materials which have been encountered and handled during construction operations, and which constitute a disposable surplus at the end of the construction period, shall be the property of the Contractor, unless otherwise directed by the City or its Engineer. Such materials shall be hauled and neatly piled, or hauled and dumped at the places designated by the Engineer, at no extra compensation.

4.4 Water Supply

Water for construction purposes may be taken from the City mains subject to the rules of the Oakland County Water Resources Commissioner's office.

Article 5 - SUPERINTENDENCE BY CONTRACTOR

- 5.1 Except where the Contractor is an individual and gives his personal superintendence to the work, the Contractor shall provide a competent superintendent, satisfactory to the City and the Engineer, on the work at all times during working hours with full authority to act for the Contractor. Any orders by the Engineer given to and received by said superintendent shall be deemed to have been given to and received by the Contractor. The Contractor shall also provide an adequate staff for the proper coordination and expediting of his work. The Contractor shall maintain a complete set of plans and specifications at the site.
- 5.2 The Contractor may set up and establish an office on or near the site. On certain large projects, the Engineer may direct the Contractor to set up an office.
- 5.3 The Contractor shall lay out his own work and he shall be responsible for all work executed by him under the Contract. He shall verify all figures and elevations before proceeding with the work and will be held responsible for any error resulting from his failure to do so.

5.4 Disorderly Employees

Disorderly, intemperate, or incompetent persons must not be employed, retained, or allowed upon the work site. Any foreman or workman who refuses or neglects to comply with the directions of the Engineer in the matter of personal conduct shall, at the request of the Engineer, be promptly discharged and shall not thereafter be re-employed without the consent of the Engineer.

5.5 Relation to Other Contractors

The Contractor shall so conduct his operations as not to interfere with or injure the work of other Contractors or workmen employed by the City on adjoining or related work, and he shall promptly make good any injury or damage which may be done to such work by him or his employees or agents. Should a contract for adjoining work be awarded to another Contractor, and should the work on any one of these contracts interfere with that of the other, the Engineer shall decide which Contractor shall cease work for the time being and which shall continue or whether the work on both contracts shall continue at the same time and in what manner. In case the territory of one contract should be the necessary means of access to another contract, the Engineer shall have power to grant reasonable privileges with respect to the transportation or movement of men, animals, appliances or materials as he may adjudge to be necessary or expedient and in the best interests of the City. Any decision which the Engineer may make as to the method and time of conducting work or the use of territory shall not be made the basis of any claim for damages, but an extension of time may be claimed, if justified by the circumstances, the same as in the case of other delays caused by the acts of the City. Any difference of opinion or conflict of interest which may arise between this Contractor and other Contractors or workmen of the City in regard to adjoining work shall be determined and adjusted by the Engineer.

5.6 Time and Sequence of Work

In general, it is the intention and understanding that the Contractor shall have control over the sequence or order of execution of the several parts of the work to be done under this Contract, and over the methods of accomplishing the required results, except as some particular sequence or method may be distinctly demanded by the Plans and Specifications or by the express provisions of this Contract; the Engineer may, however, make such reasonable requirements as may, in his judgement, be necessary for the proper and effective protection of work partially or wholly completed, and to these requirements, the Contractor shall strictly conform.

5.7 Sunday and Night Work

No Sunday work shall be done except in case of emergency or to protect from damage or injury any work that has already been done, and then only with the written consent of the Engineer, and only to such an extent as he may judge to be necessary.

Ordinarily, no night work shall be carried on which will require the presence of the Engineer or an inspector, except with the written permission of the Engineer. Night work is permissible in an emergency to the extent required to meet the emergency, but the Contractor shall notify the Engineer, as far as possible in advance, of his intentions to carry on such emergency work and of the time and place of doing it.

Article 6 - ENGINEERING SUPERVISION

The work covered by this Contract will be executed under the engineering supervision of the City Engineer, who shall have authority to inspect all materials and workmanship entering into the work, to furnish all instructions and information regarding the Plans and Specifications that may be necessary, to supply supplementary or additional plans or specifications as he may deem expedient, and to point out to the Contractor any disregard of any of the provisions of the Contract; but the right of final acceptance or condemnation of the work will not be waived at any time during its progress.

The Engineer will set suitable stakes and marks showing the locations and elevations of various parts of the work and the Contractor shall provide such labor and assistance as the said Engineer may require in setting the same. The Contractor shall take due and proper precautions for the preservation of these stakes and marks, and shall see to it that the work at all times proceeds in accordance therewith. The Engineer may provide for the inspection of any or all materials or workmanship used or intended to be used under this Contract, by assistants under his direction or otherwise, as he may deem to be advisable or expedient; but no inspection shall relieve the Contractor of his fundamental obligation to fully respect all the requirements of his Contract. Such inspection may cover any or all parts of the work, and may extend to and include the preparation or manufacture of any materials or fabricated articles intended to be incorporated in the work. The Contractor shall furnish, upon request therefor by the Engineer, such samples for examination or testing as the Engineer may prescribe. The Contractor shall furnish such labor and assistance as may be necessary for the proper handling of materials in all inspections and tests that may be required.

The Engineer and his duly authorized agents and employees may, at any time and for any purpose, enter upon the work and upon the premises occupied by the Contractor, and the Contractor shall provide proper and safe facilities by which the Engineer may have access to such parts of the work as may be required.

Article 7 - CITY'S RIGHT TO COMPLETE; SUSPENSION OR TERMINATION

It is agreed that the City has the right, when it shall become satisfied that the work provided for in this Contract will not be completed within the time limit, to furnish additional labor and material if necessary and render such other assistance as it may deem advisable, for the completion of said Contract, at the expense of the Contractor, and may retain the same out of the Contract price, or recover the same by legal proceedings.

It is agreed that the Mayor has the right to determine finally all questions as to proper performance of this Contract, or any part or portion thereof, and in case of improper, dilatory or imperfect performance thereof, to suspend the work at any time and to order the partial or entire reconstruction of the same, and if at any time the said Contractor shall abandon the work of this Contract or become habitually negligent of his obligations under it, or shall fail to prosecute the work with reasonable diligence, so that the time of final completion of the work shall be unnecessarily and intolerably delayed, or if he shall violate any of the provisions of the Contract, then and in such case the Mayor may declare this Contract forfeited and may, at address given in the proposal, notify him to discontinue all work under this Contract, or any part thereof, and thereupon he shall discontinue such work, or such part thereof, and shall cease to have any right to the possession of the ground; and the City shall thereupon have the right to complete the work or any part thereof by Contract or otherwise, as it may elect, and for that purpose to take possession and make use of such materials, tools, building appliances, and equipment as may be found upon the work, and to charge the expense thereof to the Contractor. Power is hereby given the Mayor to determine all such questions under this Contract, according to the true intent and meaning thereof.

All expenses charged under this provision shall be deducted and paid by the City of Pontiac out of any monies then due to the Contractor under this Contract, or any part thereof, and in such accounting the City of Pontiac shall not be held to obtain the lowest figures for the work of completing the contract, or any part thereof, or for insuring its proper completion, but all sums actually paid therefor shall be charged to the Contractor. In case the expenses to be charged are less than the sum which would have been payable under this contract if the same had been completed by the Contractor, the Contractor shall be entitled to receive the difference; and in case such expenses shall exceed the said sums, the Contractor shall pay the amount of the excess to the City of Pontiac.

Article 8 - ASSIGNMENT OF CONTRACT

It is agreed that the Contractor shall not assign or transfer this Contract, or subcontract any part of the work embraced in it, except with the written consent of the Mayor to do so.

It is further agreed that all parts of the work which may be performed by a subcontractor shall conform to the Plans and Specifications and be subject to all provisions of this Contract exactly as if performed by the Contractor and his immediate employees and workmen. No such letting of the work shall, in any way, diminish or weaken the responsibility of the Contractor for all parts of the work or lessen his obligation under this Contract.

It is likewise agreed that the Contractor shall not assign, either legally or equitably, any of the monies payable to him under this Contract, or his claim thereto, except with the written consent of the Mayor.

Article 9 - EXTRA WORK AND MODIFICATION

It is agreed that the said Contractor shall do such incidental or extra work in connection with this Contract as the Mayor may especially order in writing. If such extra work or any part thereof be of such character that it may be definitely covered by construction items for which unit prices are named in the proposal of this Contract, then and in that case the City will pay, and the Contractor will accept as full compensation for such extra work, or such part thereof, the amount computed by applying the unit prices to the quantities of extra work falling under the several items. Also, such extra work may be paid for at prices mutually agreed upon at the time by the City and the Contractor. But if such extra work, or any part thereof, be of a kind which may not be definitely covered by the regular pay items of this contract, and if no price therefor has been mutually agreed upon in advance, or if the work is of such a nature that it cannot be estimated with fair exactness in advance, then the City will pay, and the Contractor will accept as full compensation for such, an amount equal to the actual and necessary net cost in money to the Contractor for labor and materials actually used therein or expended thereon, plus fifteen percent (15%) of such net cost for superintendence, power, the use of tools, and plant, liability insurance, and all overhead and incidental expenses.

During the progress of any extra work which is to be paid for on the basis of net cost plus fifteen percent (15%), the Contractor will furnish to the City Engineer, at the end of each day, suitable time slips showing the name of and the number of hours worked by each workman employed thereon, the nature of work performed by him, and his rate of pay, together with suitable and adequate memoranda of the materials used therein, showing the character and amount of each such material, the source from which it was purchased, and the price paid or to be paid therefor.

The City may, at its discretion, furnish to the Contractor any materials or supplies or transportation required for extra work, and the Contractor shall not be entitled to any allowance or percentage on account of materials or supplies or transportation so furnished.

It is agreed that all extra work that may be ordered and performed under the provisions of this article shall be done by the Contractor in an effective and workmanlike manner, and shall be subject to the same restrictions and liabilities as those which apply to the general work of this Contract; and the Contractor will be responsible for the maintenance and protection of such extra work until the time of the final acceptance of the entire job by the City.

And it is further agreed that no claim against the City on account of extra work shall be valid unless such extra work has been previously ordered in writing by the Mayor, and unless such claim has been presented for payment as soon as practicable after the completion of such extra work and before the making up of the final estimate.

When it becomes necessary in the prosecution of any work or improvement under contract to make minor alterations or modifications of such contract or the plans and specifications thereof, such alterations, changes or modifications shall be made only on the written order of the Mayor.

No such order shall be made until the price to be paid for the work or material or both and the credits, if any, to be allowed by the City under the altered and modified Contract shall have been agreed upon in writing and signed by the Contractor and by the Mayor.

Article 10 - DISPUTED CLAIMS FOR EXTRA COMPENSATION

If any inconsistency, omission, or conflict is discovered in either the plans or the specifications, or if in any place the meaning of either the plans or the specifications, or both, is obscure, or uncertain, or in dispute, the Engineer will decide as to the true intent.

In case the Contractor deems extra compensation is due for work or materials not clearly covered in the contract, or not ordered by the Engineer as extra work, or due to changed or altered conditions, the Contractor shall notify the Engineer in writing of the Contractor's intention to make claim for such extra compensation before beginning work on which the Contractor intends to base a claim and shall afford the Engineer every facility for keeping actual cost of the work. The Contractor and the Engineer shall compare records and bring them into agreement at the end of each day. Failure on the part of the Contractor to give such notification or to afford the Engineer proper facilities for keeping strict account of actual cost will constitute a waiver of the claim for such extra compensation except that consideration will be given to claims to the extent that they are substantiated by City records. The determination of extra compensation made by the City, where the Contractor has failed to give proper notice of his claim for extra compensation as provided herein or has failed to afford the Engineer proper facilities for keeping strict account of actual costs, shall be final and binding on the Contractor. The filing of such notice by the Contractor and the monitoring of cost by the Engineer for said notice of claim, shall not in any way be construed to establish the validity of the claim. When the extra work in question has been completed, the Contractor shall file the claim for extra compensation with the Engineer.

Such claims shall be filed with the Engineer in a timely manner but no later than 10 days after the contract is completed. A written decision will be given to the Contractor in a timely manner, regarding the approval, partial approval, or disapproval of the Contractor's claim for extra compensation. The City will determine procedures for reviewing the Contractor's claim.

Article 11 - EXTENSION OF TIME

It is agreed that if the Contractor shall be unavoidably delayed in beginning or fulfilling this Contract by reason of excessive storms or floods, or by acts of Providence, or by general strikes, or by court injunction, or by stopping of the work by the City because of any emergency or public necessity, or by reason of extra work ordered by the City Engineer, or by any act, neglect, delay, or default on the part of

the City, the Contractor shall have no valid claim for damages on account of any such cause or delay, but he shall be, in such case, entitled to such extensions or advancement of the time period specified in the Agreement as the City Engineer shall adjudge to be just and reasonable; provided, however, that formal claim for such extension shall be made in writing by the Contractor within a week after the date upon which such alleged cause of delay shall have occurred. The closing down of the work during the winter season on account of cold weather shall not be taken as entitling the Contractor to any extension of time within the meaning of this Article.

In case the Contractor shall be delayed in the fulfillment of his obligations under this Contract, from any cause whatsoever, and in case the City shall acquiesce in the Contractor's prosecution and completion of the work, or any part of it, after the date at which it should have been finished, such acquiescence shall not operate as a waiver of any of the City's rights under this Contract, nor shall it invalidate or in any way weaken the Contractor's bonds.

Article 12 - LIQUIDATED DAMAGES

It is expressly covenanted and agreed by and between the parties hereto that time is and shall be considered as of the essence of the Contract, and in the event that said Contractor shall fail in the due performance of the entire work to be performed under this Contract, by and at the time herein mentioned and referred to in the Agreement, or within some other certain date subsequent to this to which the time limit for completion of the work may have been advanced under provisions of Article 11, the said Contractor shall pay unto the City as and for liquidated damages, and not as a penalty, the sum of **One Thousand Dollars (\$ 1,000.00)** for each and every calendar day that the said Contractor shall be in default.

Said sum of **One Thousand Dollars (\$ 1,000.00)** per day, in view of the difficulty of estimating such damages with exactness, is agreed upon as the damages which will be suffered by the City by reason of such default. It is also understood and agreed by the parties to this Contract that the liquidated damages hereinbefore mentioned are in lieu of the actual damages arising from such breach of this Contract; which said sum the City shall have the right to deduct from any monies in its possession, otherwise due, or to become due to said Contractor, or to sue for and recover compensation for damages for non-performance of this Contract at the time stipulated herein and provided for. (See also any Special Provisions for Liquidated Damages.)

Said liquidated damages are in addition to any actual damages which the City may recover under the provisions of the contract.

Article 13 - PAYMENTS TO THE CONTRACTOR

13.1 Contractor's Obligation Prior to Payment

It is agreed that before the Contractor shall demand partial or final estimates or payments, the City may require him to furnish the City satisfactory evidence that all persons that have supplied labor or materials for the work embraced under this Contract have been fully paid for the same; and that in case such evidence be not

furnished as aforesaid, such sums as the City may deem necessary to meet the lawful claims of the persons aforesaid be retained by the City from any monies that may be due or become due to him under this Contract until such liabilities shall be fully discharged and evidence thereof be furnished to the City. The Contractor agrees to make prompt settlement for all repair expenses made by the City as a result of the Contractor's work. Consent of the Contractor's surety will be required prior to final payment.

13.2 City's Obligation to Pay

It is agreed that, in consideration of the faithful and entire performance by the Contractor of his obligations under this Contract, the City shall pay to him, at the times and in the manner stipulated, the total sum as determined by calculations from the unit prices in the proposal, but diminished by such amount as the City may lawfully retain as liquidated damages under the provisions of Article 12 herein; and the Contractor shall accept the payment of such sum as full compensation for his work under this Contract.

13.3 Progress Estimates and Payments

Progress payments shall comply with Act No. 524 Public Acts of 1980. At about the first of each month, during which satisfactory progress has been made toward the final completion of the work, the Engineer will make up an estimate of the amount and value of the work which has been done under this Contract since the date of the last preceding estimate, and will report such estimate in writing to the City Director of Finance. Such estimates shall not be required to be made by strict measurements, or with exactness, but may be made either wholly or in part by appraisalment or estimation or by a consideration of accounts for labor and materials, and it shall be sufficient if it is approximate only. Any error or inaccuracy which may occur in any progress estimate may be allowed for or corrected in any subsequent estimate.

Following the rendering of such estimate by the Engineer, and as soon as practicable thereafter, the City will pay to the Contractor on account a sum equal to ninety percent (90%) of the Contract price of such work. The remaining ten percent (10%) will be retained until work is fifty percent (50%) in place. After the work is fifty percent (50%) in place, additional retainage shall not be withheld unless the City determines that the Contractor is not making satisfactory progress, or for other specific cause relating to the Contractor's performance under the Contract. If the City so determines, the City may retain not more than ten percent (10%) of the dollar value of work more than fifty percent (50%) in place.

The Director of Finance may require the Contractor, before the payment of any estimate, to file an affidavit showing the unpaid bills for materials or supplies of any kind furnished for this work.

Any time after 94% of the work is in place, the Contractor may request release of all of the retainage. The City shall be required to release the retainage plus interest to the Contractor in such case only if the Contractor provides to the City an irrevocable letter of credit in the amount of the retainage plus interest, issued by a bank authorized to do business in this State, and containing terms mutually acceptable to the Contractor and the City.

The progress estimates and payments thus provided for will include all extra work which may be done under the provisions of this Contract on the same basis as other work is included, all such extra work being regarded herein as essentially a part of this Contract, and not merely supplementary to it.

Disputes under this provision may be submitted to the decision of an agent, at the option of the City, pursuant to Section 4 of Act 524 of 1980. (MCLA 125.1564).

13.4 Measurement

Due and proper measurements will be taken by the Engineer during the progress of the work, and his estimates, based upon such measurements, shall be final and conclusive evidence of the amount of work performed under this Contract.

13.5 Final Estimate and Payment

As soon as practicable after the satisfactory completion of all the work included under this Contract, the Engineer will make final inspection of all the work and will make up a final estimate of the amount due to the Contractor under the terms of this Contract. At this time the Contractor shall file with the Director of Finance an affidavit stating that all bills have been paid in full for all materials, supplies and labor of every kind that have been furnished for this work, or stating the balance due for such materials, supplies and labor (See sample on Page 52). The Contractor shall file with the City Engineer the Contractor's Declaration found on Page 51, stating that all claims for extra payments have been satisfactorily settled and there will be no further claims. Consent of the Contractor's surety shall also be filed. The Engineer will then certify this estimate to the City Director of Finance and the Contractor will be paid the amount of said estimate, less the amounts previously paid; excepting that the City may, at its option, reserve such amount as it may deem necessary to meet the undischarged obligations of the Contractor for materials or labor expended upon this work until such obligation shall have been paid.

Article 14 - WARRANTY MAINTENANCE

If, at any time during a one-year period from the date of payment of the final estimate, the need of any repair or replacement becomes apparent, the City will at once notify the Contractor in writing, either personally or by mail at the address given in the proposal; and if within one week after such notification the Contractor has not made the necessary repairs, the City may proceed to do the required work and to charge the cost thereof against the Contractor, excepting that in the case of a repair necessary to be made at once to protect life and property, then and in

that case the City may take immediate steps to repair or barricade such defects without notice to the Contractor.

Following the performance of any such repair work by the City, and as soon as practicable thereafter, an itemized statement of the cost of such work will be sent to the Contractor by the City. In such accounting the City shall not be held to obtain the lowest figures for the doing of the work or any part thereof, but all sums actually paid therefor shall be charged to the Contractor.

Article 15 - MICHIGAN NON-DISCRIMINATION STATUTE

It is agreed that the Contractor and his subcontractors will not discriminate against an employee or applicant for employment with respect to hire, tenure, terms, conditions or privileges of employment, or a matter directly or indirectly related to employment, because of race, color, religion, national origin, age, sex, height, weight, or marital status; or because of a handicap that is unrelated to the individual's ability to perform the duties of a particular job or position. Breach of this covenant may be regarded as a material breach of the Contract.

Article 16 - LABOR LAWS AND ORDINANCES

The Contractor shall obey and abide by all laws of the State of Michigan relating to the employment of labor on public work, and all the charter provisions and ordinances of the City of Pontiac regulating or in respect to public improvements.

Article 17 - PATENTS, PATENT RIGHTS, AND TRADEMARKS

The Contractor shall indemnify, protect, defend and save the City of Pontiac, including all elected and appointed officials, all employees and volunteers, all boards, commissions and/or authorities and their board members, employees, volunteers and others working on behalf of the City, harmless against all claims or actions brought against the City by reason of any actual or alleged infringement upon patent, trademark or service mark right in any article, material, process, machine or appliance used by him in this work.

Article 18 - WORK WITHIN RAILROAD, PRIVATE, STATE OR COUNTY RIGHTS-OF-WAY

All construction work within railroad, private, State or County highway rights-of-way shall be performed by the Contractor in accordance with the requirements of the rights-of-way agreement and of the railroad or highway department having jurisdiction; including procedures of excavating, backfilling, removing and replacing pavement, maintaining and safeguarding traffic, inspection procedures of jacking pipes and encasing pipes under railroads and highways, etc. All required construction permits and surety bonds shall be furnished by the Contractor before commencing work. At the conclusion of the work, the Contractor shall furnish a written statement from the railroads and highway departments that work in rights-of-way under their jurisdiction has been completed to their satisfaction.

Article 19 - PROTECTION AND SAFETY

19.1 Protection Against Accident

The Contractor shall put up and shall maintain during the continuance of the work such barriers, lights and other protective devices and watchmen, when necessary, as will effectively prevent any accident in consequence of his work, and he shall be liable for all accidents and damages occasioned in any way by his acts or neglect, or by the acts or neglect of his agents, employees, or workmen.

19.2 Responsibility for Damage to Work

The Contractor shall assume full responsibility for loss or damage to the work during the entire construction period resulting from caving earth and from storms, floods, frosts, and other adverse weather conditions, and from all other causes whatsoever not directly due to the acts or neglect of the City, and shall turn the finished work over to the City in good condition and repair at the time of the final estimate. This responsibility of the Contractor shall cover all these elements included as extra work under this Contract in exactly the same manner as the regular work is covered.

19.3 Responsibility for Adjoining Structures

The Contractor shall have full responsibility for the protection of all property, driveways, buildings, fences, and other structures, and their foundations, along (or near) the line of the work, and shall indemnify, defend and save harmless the City of Pontiac, including all elected and appointed officials, all employees and volunteers, all boards, commissions and/or authorities and their board members, employees, volunteers and others working on behalf of the City, against all damages or alleged damages to any such structure arising out of his work.

No driveway shall be entirely closed to travel, even temporarily, except with the written consent of the Engineer, previously obtained. Highways must be suitably posted during the period in which construction work is in progress in them, and the Contractor shall be responsible for this precaution. Suitable bridges must be built across trenches at highway crossings to facilitate travel, and this same requirement shall apply likewise to private roadways.

19.4 Responsibility for Water Courses

The Contractor shall maintain in continuous and effective service all drains and water courses touched during the progress of the work. If it should become necessary, temporarily, to divert or obstruct the flow of any such water course or drain, written consent must first be obtained from the Engineer, and the Contractor shall assume full responsibility for the consequences.

19.5 Responsibility for Utilities

Certain underground structures and utilities have been shown as an aid to the Contractor, but the City does not guarantee their location or that other underground structures or utilities may not be encountered. It shall be the responsibility of the Contractor to make all arrangements with the owners of the respective utilities for the establishment of their location, prior to beginning the construction.

The Contractor shall assume full responsibility for the protection of all utilities, water, sewer, gas, telephone, or any other, either public or private, along or near the line of work, and will be held responsible for any damages to such utilities arising from his operations. If for the Contractor's convenience he desires that any portion of the utilities be moved to facilitate his operations, he shall make all necessary arrangements with the owner of the respective utilities, and pay all costs resulting from this work.

In cases where utilities, water, sewer, gas, telephone or any other, either public or private, are directly in the line of the structures being constructed, such as those being within the permissible limits of a sewer excavation or pavement excavation, and the City deems it necessary that the said utility be moved, the said company or companies, agents or superintendents will be notified by the City Engineer to remove the same within a specified time. The Contractor shall not interfere with said utility or any portion thereof until the expiration of the time specified in said notice. The Contractor will not be held responsible for any costs resulting from this work.

In all cases where there is a dispute between the Contractor and the owner of the respective utility as to necessity of moving or repairing same within City-owned right of way, the City Engineer shall make the final decision in the matter, which decision shall be binding on the respective parties, and order the respective parties to proceed accordingly.

19.6 Protection of Trees and Shrubbery

The Contractor shall take ample precautions to protect all trees and ornamental shrubbery from injury by workmen, teams, or other agencies connected with his work. Such trees or shrubbery shall be surrounded by protective posts or fencing before construction work begins if, in the judgment of the Engineer, such precautions are necessary.

19.7 Protection of Reference Points

The Contractor shall carefully preserve monuments, bench marks, reference points and stakes and, in case of willful or careless destruction, he shall be charged with the resulting expense and shall be responsible for any mistakes that may be caused by their unnecessary loss or disturbance.

19.8 Removal of Water

The Contractor shall provide all necessary pumps, pipes, drains, ditches, dikes, and other means for adequately protecting the work from damage by water, and he shall so protect it during the entire construction period. No direct payment will be made to the Contractor for removing or pumping water, or for any of the means employed in protecting the work against damage by water, but compensation therefor shall be considered as being included in the unit prices fixed in this Contract for the several structures.

Water pumped or delivered from trenches and excavations shall be disposed of in such manner as will not injure the public health, nor damage public or private property, nor injure any work complete or in progress.

19.9 Dust Control

The Contractor shall apply water or dust palliative, or both, for the alleviation or prevention of dust nuisance caused by his operations. Dust control operations shall be performed by the Contractor at the time ordered by the Engineer, but failure of the Engineer to issue such order will not relieve the Contractor of his responsibility.

Such dust control materials shall be applied as often as is necessary to control the dust. The use of road oils and waste oils to control dust is prohibited unless authorized by the Engineer.

No direct payment will be made for any such work performed or material used to control dust under this Contract.

19.10 Control of Noise

The Contractor shall eliminate noise to as great an extent as possible at all times. Air compressors shall be equipped with silencers, and the exhaust of all gasoline motors and other power equipment shall be provided with mufflers. In the vicinity of hospitals, libraries and schools, special precautions shall be taken to avoid noise and other nuisance, and the Contractor shall require strict observances of all pertinent ordinances and regulations. Any blasting permitted in such locations shall be done with reduced charges.

19.11 Erosion Control

The Contractor shall comply with the Soil Erosion and Sedimentation Control Act, Act 347 of 1972, as amended by Act 197, Public Acts of 1974 and local City or County soil erosion control programs. Also, should the local agency determine that the construction operation is in violation of the act and cites the City, the Contractor shall take immediate action, as directed by the City, to insure compliance with the Act.

19.12 First Aid

The Contractor shall at all times provide a satisfactory first aid kit at the job site. Emergency phone numbers for police, doctors, and emergency vehicles shall also be kept in the first aid kit.

19.13 Ventilation and Safety in Gas

Positive and approved means shall be provided by the Contractor for the detection of gas in existing sewers. If gas is encountered and cannot be removed by natural ventilation, then ventilating equipment of sufficient capacity and suitable type to adequately and quickly dilute the gas shall be promptly installed and operated. In all work where gas is present, no flame or other open light shall be used on the work. The Contractor shall be required to enforce a "no smoking" ban on all workmen present.

19.14 Sanitary Regulations

The Contractor shall provide for his employees an abundant and convenient supply of drinking water, taken from the City mains or from some other safe and wholesome source, and shall give orders against the use for drinking purposes of any other water in the neighborhood known to be prejudicial to the health of the workers.

The Contractor shall provide at convenient points, properly secluded from observation, a sufficient number of sanitary conveniences, and shall maintain them strictly without nuisance and without offense to the public or to residents in the vicinity of the work. The number, location, character and conditions of maintenance of these utilities must at all times be such as will meet the approval of the Engineer.

Article 20 - CLEANING UP

Upon completion of the actual work of construction, the Contractor shall clean up and leave in neat condition all the premises which he has occupied during the construction period. Before the time of the final estimate, the Contractor shall remove from the premises all surplus excavation, debris, and rubbish, and all unused materials, together with all tools and equipment, or shall deposit them at such points and in such manner as the Engineer may require.

Before leaving the grounds, he shall replace or put in good repair all fences, telephone poles and lines, roadways, and other property that may have been damaged by him during the progress of the work. Damage to crops within the limits of the right-of-way or street will be paid by the City, but the Contractor must assume responsibility for all damages outside of this right-of-way.

Article 21 - PROGRESS SCHEDULE

The CONTRACTOR shall submit a Progress Schedule to the City for review and approval prior to the pre-construction meeting.

CONTRACTOR'S DECLARATION

I hereby declare that I have not, during the period of _____
to _____ A.D., 20 ____, performed any work, furnished
any material, sustained any loss, damage or delay for any reason, including soil conditions
encountered or created, or otherwise done anything for which I shall ask, demand, sue for, or
claim compensation from the City of Pontiac or his agents, in addition to the regular items set
forth in the contract named or numbered **2021 CBDG Sidewalk Improvement Program** and
dated _____ A.D., 20 ____, for _____

executed between myself and the City of Pontiac, and in the Change Orders for work issued by
the City in writing as provided thereunder, except as I hereby make claim for additional
compensation and/or extension of time as set forth on the itemized statement attached hereto.

There (is) (is not) an itemized statement attached.

Date: _____

By: _____

Title: _____

**NOTICES TO BIDDERS,
SPECIFICATIONS
AND
SPECIAL PROVISIONS**

CITY OF PONTIAC
NOTICE TO BIDDERS
GENERAL REQUIREMENTS
1 of 1

NFE: CLF

02/20/08

All work shall be done in accordance with the City of Pontiac Standard Details and the Michigan Department of Transportation 2012 Standard Specifications for Construction and the latest revisions to the Standard Details as published by MDOT except as specifically modified in the Contract Documents

CITY OF PONTIAC
SPECIAL PROVISION
FOR
PROGRESS CLAUSE
1 of 1

NFE: JCK

2021-04-27

The Contractor shall begin work within ten (10) calendar days after receiving the "Notice to Proceed" or on or before the date designated as the starting date in the detailed Progress Schedule. The completion date for this project shall be one hundred twenty (120) calendar days from the effective date of the "Notice to Proceed".

The Contractor shall perform all work in accordance with the staged traffic control plans provided in the construction drawings. Temporary traffic and detours shall be maintained at all times. The Contractor shall complete all restoration work and pavement markings as specified in the construction drawings and as directed by the Engineer.

Failure by the Contractor to meet the above requirements and dates will result in the Contractor being assessed liquidated damages in accordance with the 2012 Standard Specifications for Construction.

The low bidder for the work covered by this proposal will be required to attend a preconstruction meeting and to submit a detailed progress schedule for approval by the Engineer. The progress schedule shall include, as a minimum, the starting and completion dates of all items of work, as well as the date the project is to be completed. The Contractor shall schedule their work such that no more than three (3) business days will elapse between major items of work. It is the intent of this provision that a continuous flow of operations will be maintained from start to finish.

CITY OF PONTIAC
NOTICE TO BIDDERS

JOB SITE SAFETY

1 of 1

NFE:CLF

02/20/08

Neither the professional activities of the Engineer, nor the presence of the Engineer or its employees and consultants at, shall relieve the Contractor and any other entity of their obligations, duties and responsibilities including, but not limited to, construction means, methods, sequence, techniques or procedures necessary for performing, superintending or coordinating all portions of the work of construction in accordance with the Contract Documents and any health or safety precautions required by any regulatory agencies. The Engineer and its personnel have no authority to exercise any control over any construction Contractor or other entity or their employees in connection with their work or any health or safety precautions. The Contractor agrees that the Contractor is solely responsible for job site safety. The Contractor also agrees, to the extent permitted by law, that the Owner, Engineer and Engineer's consultants shall be indemnified by the Contractor for claims, demands, damages, judgments, losses, interest, attorney's fees, litigation costs and expenses of any kind, at any time, for bodily injury and or property damage, arising out of or in any way connected to the Contractor's work or acts related to the Project. The Contractor also agrees that the Owner, Engineer and Engineer's consultants shall be made additional insureds under the Contractor's general liability insurance policy.

CITY OF PONTIAC

NOTICE TO BIDDERS

UTILITY COORDINATION

1 of 1

NFE: JCK

2021-04-26

Description

The Contractor shall cooperate and coordinate construction activities with the owners of utilities as stated in Section 104.07 of the 2003 MDOT Standard Specifications for Construction. In addition, for the protection of underground utilities, the Contractor shall follow the requirements in Section 107.12 of the 2003 MDOT Standard Specifications for Construction. Contractor delay claims, resulting from a utility, will be determined based upon Section 109.03 of the 2003 MDOT Standard Specifications for Construction.

The following public utilities have facilities located within the right-of-way:

Electric - Distribution:

DTE Energy
1530 Trombly Street
Detroit, MI 48211
Contact: Laura Toporowski 630-336-2020

Telephone:

AT&T
54 N. Mill Street
Pontiac, MI 48342
Contact: Matt Silwa 248-877-0762

Gas:

Consumers Energy
4600 Coolidge Hwy
Royal Oak, MI 48073
Contact: Ernie Martyniuk 248-433-5868

Cable Television:

Comcast Cable
25626 Telegraph Rd
Southfield, MI 48033
Contact: Michael Marlow 248-809-2765

Water Main & Sanitary Sewer:

Oakland County W.R.C.
1 Public Works Dr
Waterford, MI 48328
Contact: Rick DeVisch 248-858-4939

Electric – Community Lighting:

DTE Energy
15600 19 Mile Rd
Clinton Twp, MI 48038
Contact: Reggie Brown 586-412-3207

Storm drain, water main and street lighting improvements shall be constructed as identified in the construction plans or specifications.

On all projects: "Three Working Days before you Dig – Call MISS DIG (800)482-7171"

Existing service facilities, which are located within grading or structure limits, will be moved or adjusted by the owners to locations or elevations designated by the Engineer or will be removed entirely from the right of way. Owners of public utilities will not be required by the City to move additional poles or structures in order to facilitate the operation of construction equipment unless it is determined by the Engineer that such poles or structures constitute a hazard to the public or are extraordinarily dangerous to the Contractor's operations.

CITY OF PONTIAC
SPECIAL PROVISION
FOR
USE OF CITY WATER
1 of 1

NFE: JCK
Revised: JAC

03/07/2018
05/19/2021

DESCRIPTION

The water distribution system is owned by the Oakland County Water Resource Commissioner (OCWRC), and is available for use by the Contractor. The Contractor MUST apply for and have a permit for water use in the possession of the individual taking the water from the City system. Unauthorized use will not be permitted. The Oakland County Sheriffs has been instructed to halt unauthorized use of city water.

The Contractor is advised to contact the Oakland County Water Resources Commissioners Office to ascertain the procedures for obtaining a permit and for paying the required fees for such use.

MEASUREMENT AND PAYMENT

The permit fee for water use is the Contractor's responsibility. These fees shall be considered incidental to the project and shall not be paid for separately.

CITY OF PONTIAC
SPECIAL PROVISION
FOR
MAINTAINING TRAFFIC

1 of 4

NFE: JCK
REV: JAC

2021-04-27
2021-05-21

General

Traffic shall be maintained by the Contractor throughout the project in accordance with Section 104.11 and 812 of the Michigan Department of Transportation 2012 Standard Specifications for Construction, the 2011 Michigan Manual of Uniform Traffic Control Devices (MMUTCD) (Revised September 2013), and any supplemental specifications in this proposal.

City of Pontiac maintenance crews and/or City contracted forces may perform maintenance work within or adjacent to the Construction Influence Area (CIA). This work will be coordinated with the Contractor through the Engineer to minimize interference. No additional payment will be made to the Contractor for the joint use of the traffic control items.

The Contractor shall coordinate this work with other Contractors performing work within the Construction Influence Area (CIA) or adjoining areas to avoid conflicts in the maintenance of traffic, construction signing, and to provide for the orderly progress of contract work. Where possible, this special provision will specify upcoming projects in the area.

The Contractor is to note Section 104.08 of the Michigan Department of Transportation 2012 Standard Specifications for Construction for the requirements of cooperation with other Contractors.

The Contractor shall be responsible for the protection of vehicular and pedestrian traffic, work in progress and construction workers through the implementation of traffic control devices.

Notification: The Contractor shall notify the Engineer, local police department, local fire department, and other emergency response units at least **72 hours** before implementing any road closures, bridge closures, ramp closures, lane closures, detours, or major traffic shifts. Contractor shall notify MDOT of traffic control placement in MDOT right-of-way as required by permit.

Traffic Restrictions – General

No additional lane closures shall be allowed on the following weekends: Memorial Day, Fourth of July, Woodward Dream Cruise (August 19-21), and Labor Day.

The Engineer will determine the duration of each holiday period and/or special event for the purpose of prohibiting lane closures, detours, or other traffic disruptions.

Prior to opening any lanes, the Contractor shall remove, by sweeping, all accumulated debris that has collected within the closed lane. The cost of sweeping shall be included in the cost of other contract pay items.

Equipment and material stored on site must have prior approval of the Engineer and shall be stored beyond the clear zone of the traveled roadway. Any additional signs or devices required to protect the motoring public from stored equipment or material will be at the Contractor's expense.

CITY OF PONTIAC
SPECIAL PROVISION
FOR
MAINTAINING TRAFFIC
2 of 4

NFE: JCK
REV: JAC

2021-04-27
2021-05-21

The Contractor shall implement shoulder closures, lane closures, detours, etc., according to applicable MDOT Typical Traffic Control Typicals, the suggested sequence of events and the 2011 Michigan Manual of Uniform Traffic Control Devices (MMUTCD) (Revised September 2013). All changes in the traffic control plans, proposed by the Contractor, require prior approval from the Engineer to implementation.

The Contractor shall maintain reasonable access, as defined by the Engineer, to all businesses, homes and intersecting streets at all times. Alternating business drives may be closed if a business has more than one drive that operates bi-directionally.

Traffic Restrictions – Hours

Allowable work hours for this project are Monday through Saturday, 7:00 a.m. to 7:00 p.m., unless otherwise approved by the Engineer.

Available work hours may be restricted by local ordinances (i.e. work hours, noise restrictions). It is the Contractor's responsibility to be aware of these restrictions and account for them in the work schedule. The Contractor may request noise and/or work hour variances from the Local Governments. All costs occurred in requesting these variances shall be borne by the Contractor. Hourly restrictions are subject to change by the Engineer based on traffic volume.

At non-signalized intersections, the intersecting street may be completely closed during working hours providing that adjacent interconnecting streets afford access to the closed street. If no alternative access to the street is available, a flagging operation must be used at the intersection.

At signalized intersections, the work shall be completed as describe in this section. Traffic stoppages (if required) shall be limited to 10 minute intervals after which traffic will be allowed to proceed until the last vehicle in the queue has passed or after traffic has been allowed to free flow for a period of five minutes or longer.

Permits: The Contractor shall obtain all necessary permits from local governments which require them prior to placing construction signing on local roads. The costs associated with obtaining these permits shall be the responsibility of the Contractor and will not be paid for separately.

CITY OF PONTIAC
SPECIAL PROVISION
FOR
MAINTAINING TRAFFIC
3 of 4

NFE: JCK
REV: JAC

2021-04-27
2021-05-21

Traffic Control Devices

All traffic control devices and their use shall conform to the Michigan Manual of Uniform Traffic Control Devices (MMUTCD), 2005 edition, and as specified herein.

Quality Standards – All traffic control devices including: signs, barricades, vertical panels, drums, warning lights, arrow boards, and changeable message signs shall meet the requirements of American Traffic Safety Services Association (ATSSA).

Traffic control devices moved to facilitate the Contractor's operation shall be reset by the end of the work day. The Contractor shall routinely maintain the traffic control devices including but not limited to, proper alignment, weighting with ballast, cleaning and replacing damaged devices.

Signs – All temporary signs shall be installed as defined in the MDOT Special Detail WZD-125-E, when applicable. Supports for temporary supports shall be secured with sand bags at all times during daily construction operations.

All warning signs shall be fabricated utilizing fluorescent prismatic retro-reflective sheeting in accordance with Section 922 of MDOT 2012 Standard Specifications for Construction.

Advance warning signs (4 foot x 4 foot) shall be placed on all cross streets, freeways, entrance ramps, and exit ramps where construction activities may be encountered as directed by the Engineer.

Temporary signs indicating sidewalk closures shall be provided for each sidewalk ramp reconstruction.

Temporary warning, regulatory, and guide signs not applicable to the current traffic operation or lane closures shall be removed, covered, or laid down with the legs removed as directed by the Engineer. Payment for any of these operations will be included in the cost for Temporary Signs.

CITY OF PONTIAC
SPECIAL PROVISION
FOR
MAINTAINING TRAFFIC
4 of 4

NFE: JCK
REV: JAC

2021-04-27
2021-05-21

Temporary signs damaged by construction activities shall be replaced at the Contractor's expense.

When lane closures are in place, the Contractor shall completely cover all conflicting warning, regulatory, and guide signs in accordance with the MDOT 2012 Standard Specifications for Construction.

Channeling Devices and Barricades – All channelizing devices shall be Plastic Drums with High Intensity Sheeting, Lighted from MDOT's Qualified Products List (QPL) of the Materials Sampling Guide.

Traffic Control Item Quantities – The Contractor shall setup lane closures, detours, and any other traffic control according to applicable MDOT Typical Traffic Control Drawings and the 2011 Michigan Manual of Uniform Traffic Control Devices (MMUTCD) (Revised September 2013). All proposed traffic control plans require approval from the Engineer prior to implementation.

Measurement and Payment – The completed work for Maintaining Traffic shall not be paid for separately, but shall be considered included in other items of work on the project.

CITY OF PONTIAC
SPECIAL PROVISION
FOR
REPLACEMENT CRITERIA
1 of 1

NFE: JCK

03/07/2018

This work shall be done in accordance with the Michigan Department of Transportation 2012 Standard Specifications for Construction, except as follows:

DESCRIPTION

Sidewalks identified as hazardous generally fall into one of the following categories:

- A. Vertical displacement to an adjacent flag of sidewalk is greater than ½ inch.
- B. The surface is spalled more than 50% and retains water.
- C. Any other condition that allows water to stand on the sidewalk or creates a danger to pedestrians.

Sidewalk may be marked for removal and replacement by individual flags (5'x5'), or an area may contain several lineal feet, depending upon condition, and leaving the adjacent sidewalk in place.

Asphalt or concrete driveways encountered in an area of sidewalk replacement shall be saw cut and removed to a typical distance of two (2) feet and replaced with in-kind materials as called for in the typical details. If, in the opinion of the engineer, more than two (2) feet is required to insure a smooth transition to the new sidewalk grade the contractor shall remove as directed. The contractor shall be paid at the appropriate unit price for the item constructed.

Drive approaches that will not match the grade of the new sidewalk shall be removed and replaced with concrete at the thickness called for on the plans and paid for at the appropriate item constructed.

The contractor shall use due care when removing sidewalk to minimize damage to the adjoining walks, driveways, trees, and other existing features. The contractor shall be responsible for damages caused by neglect or careless workmanship.

CITY OF PONTIAC
SPECIAL PROVISION
FOR
DISPOSAL OF EXCAVATED OR SURPLUS MATERIAL
1 of 1

NFE: JCK

03/07/2018

This work shall be done in accordance with the Michigan Department of Transportation 2012 Standard Specifications for Construction, except as follows:

DESCRIPTION

Surplus materials such as trees, brush, stumps, culverts, and all excavated materials shall become property of the contractor. The contractor shall make their own arrangements for the disposal of all material.

Concrete and asphalt materials generated from the removal of sidewalks, drive approaches, curb and gutter, and pavement shall become the property of the contractor. The contractor shall make their own arrangements for the disposal of this material.

All materials shall be disposed of according to all applicable local, state, and federal rules and regulations.

CITY OF PONTIAC
SPECIAL PROVISION
FOR
ROOT REMOVAL AND STUMP REMOVAL
1 of 1

NFE: CLF
REV: JAC

04/12/2018

This work shall be done in accordance with the Michigan Department of Transportation 2012 Standard Specifications for Construction, except as follows:

DESCRIPTION

The contractor shall remove all tree roots, and stumps/ trunks, which conflict with the proposed line and grade of replacement sidewalk, as directed by the engineer.

CONSTRUCTION METHODS

After existing sidewalk is removed to provide for the construction of new sidewalk the contractor shall identify all tree roots and stumps/trunks which conflict with the proposed sidewalk construction.

The existing tree roots which interfere with the correct line and grade of replacement sidewalk shall be removed with sharp tools designed for tree root removal. The contractor shall cleanly and accurately remove tree roots to the conflict limits identified by the engineer based on individual site conditions. The contractor shall remove roots. Root removal which can be achieved by the use of hand shovel or pruning shears will not be considered for payment. The contractor shall be responsible for the disposal of all material generated from this work.

The existing tree stumps/ trunks which interfere with the correct line and grade of replacement sidewalk shall be removed with sharp tools designed for tree stump / trunk removal. The contractor shall cleanly and accurately remove stumps / trunks to the conflict limits identified by the engineer based on individual site conditions. It is not the intent of this work to completely remove stumps/trunks but only the portion which conflicts with the proposed work. The contractor shall remove stumps / trunks by machine saw-cutting or grinding which are not exceedingly destructive to the tree or its root system. The contractor shall be responsible for the disposal of all material generated from this work.

MEASUREMENT AND PAYMENT

The work of removing tree roots and stumps/trunks shall be paid for at the contract unit price for the following contract pay items:

| | |
|---------------------|------|
| Root Removal | Each |
| Trunk/Stump Removal | Each |

CITY OF PONTIAC
SPECIAL PROVISION
FOR
TIMBER WALL
1 of 1

NFE: JAC

05/21/2021

This work shall be done in accordance with the Michigan Department of Transportation 2012 Standard Specifications for Construction Sections 206 and 912 and AWPB LP-22 Specifications, except as follows:

DESCRIPTION

The contractor shall construct a timber retaining wall as shown on Exhibit 3 in Appendix A of these construction documents. Locations and limits for the proposed wall shall be constructed as directed by the Engineer.

CONSTRUCTION METHODS

After existing sidewalk is removed, the Contractor shall removal/excavate all materials behind the proposed sidewalk to provide enough space to construct the proposed wall. Earth material behind the wall shall be shored and supported during all work associated with the wall construction.

The proposed wall materials shall be constructed with approved materials in Section 912 of the Michigan Department of Transportation 2012 Standard Specifications for Construction and as described in Exhibit 3 of Appendix A.

Backfill material shall be installed as shown on Exhibit 3 of Appendix A, Section 206 of the Michigan Department of Transportation 2012 Standard Specifications for Construction, and the AWPB Specifications.

The existing ground shall be blended to the top of the proposed wall. The Contractor shall be responsible for the disposal of all material generated from this work. Restoration shall be provided as described in these construction documents.

MEASUREMENT AND PAYMENT

All materials, workmanship, labor, equipment, materials and disposal for work associated with the construction of the Timber wall shall be paid for at the contract unit price for the following contract pay item:

Timber Wall

Lineal Foot

CITY OF PONTIAC

SPECIAL PROVISION
FOR
RESTORATION
1 of 1

NFE: JCK

02/14/2018

This work shall be done in accordance with the Michigan Department of Transportation 2012 Standard Specifications for Construction, except as follows:

DESCRIPTION

Restoration shall consist of, but not be limited to, providing all labor, materials, and equipment necessary for the preparation of the foundation for seeding, fertilizing and mulching all areas to be restored and the placement of seed, fertilizer, mulch and watering as required.

CONSTRUCTION METHODS

Removal areas shall include room for placement of the sidewalks (including forms for both sides of the walk) as well adequate removal space beyond the sidewalk forms to grade a mowable slope, as shown in Exhibit 3.

Restoration work includes placement of screened topsoil (2" depth), seed, fertilizer, and mulch at designated rates. Thoroughly water entire area upon initial placement. A minimum of two additional waterings as directed by the Engineer shall be required.

In general, restoration will be required in all areas disturbed by the Contractor's operations.

RATES OF APPLICATION

In those areas where restoration is required, the following rates of application will apply.

| | | |
|-----------------|--|----------|
| Topsoil..... | Screened..... | 2 In |
| Seed..... | Class A Seed Mixture..... | 220 #/Ac |
| Fertilizer..... | Chemical Fertilizer Nutrient, Class A..... | 228 #/Ac |
| Mulch..... | Mulch..... | 2 Ton/Ac |

MEASUREMENT AND PAYMENT

The work of restoring disturbed areas shall not be paid for separately, but shall be considered incidental to the appropriate construction item as shown in the plans or as directed by the Engineer.

MICHIGAN
DEPARTMENT OF TRANSPORTATION

SPECIAL PROVISION
FOR
QUALITY CONTROL AND ACCEPTANCE OF PORTLAND CEMENT CONCRETE
(FOR LOCAL AGENCY PROJECTS ONLY)

CFS:JFS

1 of 21

APPR:TES:DBP:06-11-18
FHWA:APPR:06-14-18

a. Description. The Contractor must administer quality control (QC) and the Department will administer quality assurance (QA) procedures that will be used for acceptance of and payment for all Portland cement concrete (PCC) for the project. Except as explicitly modified by this special provision, all materials, test methods, and PCC mixture requirements of the standard specifications and the contract apply.

Do not place concrete until the Engineer's daily startup testing verifies that the fresh concrete properties have been met, in accordance with subsection d.2 of this special provision.

Provide the Engineer a minimum 24 hours notification prior to each concrete placement.

1. Terminology.

Air Content of Fresh Concrete. The recorded total air content of fresh concrete sampled and tested according to this special provision.

Air Content Test Results. The recorded air content of fresh concrete corresponding to the strength test specimens that were molded for acceptance.

Alkali-Silica Reactivity (ASR). A chemical reaction which occurs over time within concrete between high alkaline cement paste and reactive forms of silica found in some aggregates. In the presence of moisture, an expansive ASR gel is formed which can exert pressure within the concrete, causing random cracking and premature deterioration of the concrete. See subsection c.5.A of this special provision.

Base Price. Price established by the Department to be used in calculating incentives or adjustments to pay items and shown in the contract.

Concrete Mix Design. The process, by which the concrete mixture performance characteristics are defined, based on selected materials, performance requirements, environmental exposure considerations, placement methods, and other factors that control the plastic and hardened properties of the concrete in efforts to produce an economical and durable product.

Job Mix Formula (JMF). The actual batch quantities (mixture proportions) of each constituent included in the concrete mixture, based on adjustments to the target weights attained from the mix design process, necessary to optimize the concrete mixture properties.

Pay Factor (PF). The factor that is determined according to subsections d.3 of this special provision, used to calculate the price adjustment for a discrete quantity of concrete relative

to its respective level of quality. Pay factor will not exceed 1.00. Therefore, there will never be a positive pay adjustment.

Price Adjustment (ADJ). The price adjustment applied to the quantity of concrete represented by the respective quality index analysis described in subsections d.3 of this special provision.

Production Lot. A discrete cubic yard quantity of concrete containing the same JMF and used for the same application, as described in subsection d.2 of this special provision.

Quality Assurance (QA). Activities administered by the Engineer dealing with acceptance of the product, including, but not limited to, materials selection, sampling, testing, construction inspection, and review of Contractor QC documentation. All concrete QA sampling and testing will be administered by the Department. Department administered QA is described in section d of this special provision.

Quality Control (QC). All activities administered by the Contractor to monitor, assess, and adjust production and placement processes to ensure the final product will meet the specified levels of quality, including, but not limited to, training, materials selection, sampling, testing, project oversight and documentation. Contractor administered QC is described in section c of this special provision.

QC Action Limits. A range of values established by the Contractor in the QC plan that, if exceeded, requires that corrective action be taken by the Contractor to restore the continuity and uniformity of the mixture and methods in conformance with specification requirements. The QC action limits must not exceed the QC suspension limits.

QC Plan. The project-specific plan developed by the Contractor describing, in detail, all aspects of production and construction for the project to ensure consistent control of quality to meet specification requirements.

QC Plan Administrator. An employee of, or consultant engaged by the Contractor, responsible for developing and overseeing all aspects of QC for the project. This includes, but is not limited to preparing the QC plan, managing the Contractor QC personnel, communicating routinely with the production personnel to ensure quality, initiating corrective action and suspending operations when the process is found to be producing non-conforming materials, and preparing and submitting all necessary QC documentation to the Engineer within the specified time period.

QC Suspension Limits. A range of values defined in Table 1 that, if exceeded on a single QC test, requires that the Contractor suspend operations and determine, correct, and document the deficiencies before resuming production. The QC suspension limit must not exceed specification requirement thresholds.

Sample. A representative quantity of concrete taken during production which is used to measure the quality characteristics for the concrete.

Sampling Rate. The number of times the fresh concrete is sampled, as described in subsection d.2 of this special provision.

Small Incidental Quantity. A single day's placement of less than 20 cubic yards of concrete used for non-structural or non-pavement related applications, including, but not limited to:

curb and gutter, sidewalks and sidewalk ramps (excluding driveways and driveway ramps), installing sign or fence posts, guard rail or cable rail foundations (excluding end anchorage foundations), or other contract items where the small quantity of concrete is not paid for separately, as approved by the Engineer. Requirements for small incidental quantity consideration are described in subsections c.5.G, d.2.B and d.3 of this special provision. The corresponding weekly QA test results must meet specification limits defined in Table 3.

Specification Limits. The threshold values placed on a quality characteristic used to evaluate the quality of the material.

Strength Sample Test Result. The average of the two companion 28-day compressive strength test specimens taken from the same sample of concrete is considered a strength sample test result.

Strength Test Specimen. A strength test specimen is an individual 6-inch by 12-inch strength test cylinder or 4-inch by 8-inch strength test cylinder molded and cured according to *AASHTO T23/ASTM C 31* and tested according to *AASHTO T22/ASTM C 39*. All respective QC or QA strength test specimens must be the same nominal size. Strength test specimen cylinder size of 4-inch by 8-inch is permitted only if the nominal maximum coarse aggregate particle size, as specified for the coarse aggregate in the concrete mixture, is 1-inch, or less.

Sublot. A portion of a production lot, represented by a complete set of QA tests, as described in subsection d.2.A of this special provision. The Engineer and the Contractor may agree to reduce the typical subplot size based on project staging or other project conditions.

Supplementary Cementitious Materials (SCM). A mineral admixture (slag cement, fly ash) used to replace a portion of the Portland cement, either individually or as a blended cement, in the concrete mixture. SCM requirements are described in subsection c.5 of this special provision.

b. Materials. Mixture requirements must be in accordance with the contract.

c. Contractor Administered Quality Control (QC).

1. Contractor Quality Control Plan (QC plan). Prepare, implement, and maintain a QC plan specific to the project for concrete that will provide quality oversight for production, testing, and control of construction processes. The QC plan must be in conformance with the contract and must identify all procedures used to control production and placement including when to initiate corrective action necessary to maintain the quality and uniformity of the work.

Develop concrete mix designs and JMFs, as specified, and conduct QC sampling, testing, and inspection during all phases of the concrete work at the minimum frequency, or at an increased frequency sufficient to ensure that the work conforms to specification requirements.

Project-specific items required in the QC plan include (where applicable), but are not limited to the following:

A. Organization chart.

- B. QC Plan Administrator and contact information.
- C. The name(s) and credentials of the QC staff.
- D. Methods for interaction between production and QC personnel to engage timely corrective action, including suspension of work.
- E. Coordination of activities.
- F. Documentation, procedures, and submittals.
- G. Project and plant specifics.
- H. Concrete production facilities inspections and certifications.
- I. Current testing equipment calibration documentation including calibration factor.
- J. Testing and initial field curing facilities for QC and QA strength test specimens (AASHTO T23/ASTM C 31).
- K. Stockpile management plan.
- L. Corrective action plan.
- M. Mixing time and transportation, including time from batching to completion of delivery and batch placement rate (batches per hour), along with the manufacturer's documentation relative to the batching equipment's capabilities in terms of maximum mixing capacity and minimum mixing time (*ASTM C 94*).
- N. Placement and consolidation methods including monitoring of vibration, depth checks, and verification of pavement dowel bar alignment.
- O. Process for monitoring stability of air content of fresh concrete during concrete production and placement.
- P. Hot and cold weather protection considerations and methods.
- Q. Control charts with action and suspension limits.
- R. Verification for non-deleterious alkali-silica reactivity (see subsection c.5.A of this special provision).
- S. Mix design and JMFs.
- T. Proposed production lot size and location for use of each JMF on the project.
- U. The frequency of sampling and testing.
- V. Handling, protection, initial curing, and transporting of strength test specimens (*AASHTO T23/ASTM C31*).

- W. Methods to monitor construction equipment loading and open-to-traffic strengths.
- X. Finishing and curing procedure.
- Y. Ride quality control.
- Z. List of QC records to be submitted to the Engineer in accordance with subsection c.2 of this special provision.

Submit the QC plan, for the appropriate items of work, to the Engineer for review a minimum of 10 working days before the start of related work. The Engineer will notify the Contractor of any objections relative to the content of the QC plan within 5 working days of receipt of the QC plan. Do not begin concrete placement before acceptance of the QC plan by the Engineer. If the approved QC plan fails to provide acceptable work, or acceptable control of the work, the Engineer may require the Contractor to revise the QC plan. Revisions to the QC plan must be approved by the Engineer prior to resuming work.

2. QC Records. Maintain complete records of all QC tests and inspections. Document what action was taken to correct deficiencies. Include sufficient information to allow the test results to be correlated with the items of work represented.

Furnish one copy of all QC records, including test reports for the fresh concrete placement, to the Engineer within 24 hours after the date covered by the record in a format acceptable to the Engineer. The Engineer will withhold acceptance of the concrete for failure to provide properly documented and timely QC records and reports.

If the Engineer is performing QA sampling and testing at the same time the Contractor is performing QC sampling and testing, all associated QC records must include the appropriate production lot identification number that correlates with the Department's QA production lot identification number.

3. Personnel Requirements. The QC Plan Administrator must have full authority and responsibility to take all actions necessary for the successful implementation of the QC plan, including but not limited to, the following:

- A. Monitoring and utilizing QC tests, control charts, and other QC practices to ensure that delivered materials and proportioning meets specification requirements.
- B. Monitoring materials shipped to the project, prior to their use, to ensure their continued compatibility toward producing consistent quality.
- C. Periodically inspecting all equipment utilized in transporting, proportioning, mixing, placing, consolidating, finishing, and curing to ensure proper operation.
- D. Monitoring materials stockpile management, concrete batching, mixing, transporting, placement, consolidation, finishing, and curing to ensure conformance with specification requirements.
- E. Maintaining and submitting all QC records and reports.
- F. Directing the necessary corrective action to ensure continual conformance within

the QC action limits.

G. Suspending production for the project when suspension limits are exceeded.

H. Conducting or monitoring adjustments to the JMF.

Individuals performing QC tests must demonstrate that they are proficient and capable of sampling and testing concrete or aggregate, where applicable, in accordance with the associated test procedures and Department requirements prior to commencement of related work. Any adjustments to the JMF must be made by a certified concrete technician (Michigan Concrete Association (MCA) Michigan Level II).

4. QC Laboratory Requirements. Laboratories, including field laboratories and all associated testing equipment that prepare concrete mixes or perform QC testing, must demonstrate to the Engineer that they are equipped, staffed, calibrated, and managed so as to be capable of batching, and testing PCC in accordance with the applicable test methods and procedures. Mix designs and their accompanying JMFs must include a statement, signed by a certified concrete technician (MCA Michigan Level II), that all applicable standard test methods have been followed in verifying the mix design and JMF.

5. Mix Design and Documentation. Design concrete mixtures meeting the requirements specified in Table 1. Provide the grade of concrete for the section number reference application specified in Table 1, or as specified in the contract. Request variance in writing when proposing a mix design that exhibits temperature, slump or air content other than those specified. Include the proposed mix design, JMF, and associated trial batch verification test data. Do not use a grade of concrete with a lower specification limit (LSL) 28-day compressive strength greater than what is designated for the application.

Blended cement meeting the requirements of *ASTM C 595 Type IL* is permitted.

Ensure supplementary cementitious materials are from an MDOT Approved Manufacturer. Slag cement must meet the requirements of subsection 901.06 of the Standard Specifications for Construction. Fly ash must meet the requirements of subsection 901.07 of the Standard Specifications for Construction.

Secure prior approval from the Engineer to use concrete intended for early opening to traffic to facilitate driveway gaps or other features necessary for required local access.

Unless otherwise specified in the contract, set accelerating admixtures are prohibited.

Optimized aggregate gradation is required for high performance concrete and concrete mixtures that are placed using a pump. Concrete mixtures for tremie and drilled shaft applications do not require optimized aggregate gradation. The physical requirements for coarse and intermediate aggregates specified in subsection 902.03.C of the Standard Specifications for Construction apply to high performance concrete pavement mixtures. The physical requirements for aggregates used in concrete mixtures for all other applications will be according to the contract.

Unless otherwise specified in the contract, provide either concrete Grade P1 or Grade D for bridge approach slab applications.

Unless otherwise specified in the contract, do not exceed 40 percent replacement of the Portland cement in the concrete mixture with a supplementary cementitious material. Do not exceed 40 percent total replacement of the Portland cement if more than one supplementary cementitious material is used in the concrete mixture.

Use the combined weight of all cementitious materials to determine compliance with the maximum water-cementitious ratio and cementitious material content requirements specified in Table 1.

For night casting, where applicable, a water-reducing admixture may be used in lieu of a water-reducing and retarding admixture, provided the concrete can be placed and finished in the sequence specified on the plans prior to initial set, is not subjected to residual vibration, or is not within the areas influenced by dead load deflections as a result of adjacent concrete placement operations. When the maximum air temperature is not forecast to exceed 60 degrees F for the day, the Contractor may use a water-reducing admixture or a water-reducing retarding admixture.

Table 1: Minimum Mix Design Requirements for Concrete

| Mix Design Parameter | Grade of Concrete | | | | | | | | | | | | | | | | | | | | | | | | | | | | |
|--|--|------------------------------------|------------------|----------|-----------|--|--|-------------------|------------------|-------------------------|------------------------------------|-----------------------------------|-----------------------|--------------------------------------|---------------------|------------------------------------|---------------------------------|--------------------|------------------------|--|--|---|----------------------|-------------|--|----------------------|-------------------|-----------------------------|--|
| | P1M (a,b,e) | P1 (a,b) | D,DM (a,b,e) | T | S1 (a) | S2,S2M (a,b,e) | S3/P2 (a) | | | | | | | | | | | | | | | | | | | | | | |
| Lower Specification Limit (LSL) (28-day compressive, psi) | 3500 | 3500 | 4500 | 3500 | 4000 | 3500 | 3000 | | | | | | | | | | | | | | | | | | | | | | |
| Rejection Limit for an Individual Strength Sample Test Result | 3000 | 3000 | 4000 | 3000 | 3500 | 3000 | 2500 | | | | | | | | | | | | | | | | | | | | | | |
| Maximum Water/Cementitious Ratio (lb/lb) (c) | 0.45 | | | | | | | | | | | | | | | | | | | | | | | | | | | | |
| Cementitious Material Content (lb/yd3) (d) | 470-564 | 517-611 | 517-658 | 517-611 | 517-611 | 517-611 | 489-517 | | | | | | | | | | | | | | | | | | | | | | |
| Air Content (percent) (f) | 5.5-8.5 | | | | | | | | | | | | | | | | | | | | | | | | | | | | |
| Slump (inch) (max.) | (g) | | | | | | | | | | | | | | | | | | | | | | | | | | | | |
| Section Number Reference (h) | 602, 603 | 602, 603, 801, 802, 803, 810 | 706, 711, 712 | 706, 718 | 705 | 401, 706, 712, 713, 718, 801, 802, 803, 810, 819 | 402, 403, 602, 803, 804, 806, 808, 810, 813, 814 | | | | | | | | | | | | | | | | | | | | | | |
| <p>a. If the local average minimum temperature in the next 10 consecutive days is forecast to be below 40 degrees F, submit a revised QC plan for the Engineer's approval, addressing in detail changes in materials, concrete batching and mixing processes, construction methods, curing, and protection of the in situ concrete to ensure that the necessary quality characteristics of the hardened concrete product will not be compromised as a result of the cold weather. The revised QC plan must be approved by the Engineer prior to cold weather concrete placement. Do not remove supplementary cementitious material from the concrete mixture.</p> <p>b. Use aggregates from only geologically natural sources for pavement, shoulder, miscellaneous pavement (including ramps), concrete pavement overlay, bridge approach slab, structural concrete, drilled shaft, bridge railing, and bridge sidewalk applications.</p> <p>c. Use admixtures as listed in the Qualified Products Lists to reduce mixing water. Ensure concrete in concrete diaphragms contains a water-reducing admixture, or a water-reducing retarding admixture.</p> <p>d. Type III cement is not permitted.</p> <p>e. For grades of concrete requiring optimized gradation, aggregates must meet the physical requirements specified in subsection 902.03.C of the Standard Specifications for Construction.</p> <p>f. For action, suspension, and specification limits, see Tables 2 and 3, where applicable.</p> <p>g. The maximum slump for Grades P1, P1M, and P2 concrete is 3 inches or as documented on the approved JMF. All other grades of concrete will be according to Table 701-1 of the Standard Specifications for Construction.</p> | | | | | | | | | | | | | | | | | | | | | | | | | | | | | |
| <p>h. Section Number Reference:</p> <table border="0"> <tr> <td>401 Pipe Culverts</td> <td>402 Storm Sewers</td> </tr> <tr> <td>403 Drainage Structures</td> <td>602 Concrete Pavement Construction</td> </tr> <tr> <td>603 Concrete Pavement Restoration</td> <td>705 Foundation Piling</td> </tr> <tr> <td>706 Structural Concrete Construction</td> <td>711 Bridge Railings</td> </tr> <tr> <td>712 Bridge Rehabilitation-Concrete</td> <td>713 Bridge Rehabilitation-Steel</td> </tr> <tr> <td>718 Drilled Shafts</td> <td>801 Concrete Driveways</td> </tr> <tr> <td>802 Concrete Curb, Gutter and Dividers</td> <td>803 Concrete Sidewalk, Sidewalk Ramps, and Steps</td> </tr> <tr> <td>804 Concrete Barriers and Glare Screens</td> <td>806 Shared Use Paths</td> </tr> <tr> <td>808 Fencing</td> <td>810 Permanent Traffic Signs and Supports</td> </tr> <tr> <td>813 Slope Protection</td> <td>814 Paved Ditches</td> </tr> <tr> <td>819 Electrical and Lighting</td> <td></td> </tr> </table> | | | | | | | | 401 Pipe Culverts | 402 Storm Sewers | 403 Drainage Structures | 602 Concrete Pavement Construction | 603 Concrete Pavement Restoration | 705 Foundation Piling | 706 Structural Concrete Construction | 711 Bridge Railings | 712 Bridge Rehabilitation-Concrete | 713 Bridge Rehabilitation-Steel | 718 Drilled Shafts | 801 Concrete Driveways | 802 Concrete Curb, Gutter and Dividers | 803 Concrete Sidewalk, Sidewalk Ramps, and Steps | 804 Concrete Barriers and Glare Screens | 806 Shared Use Paths | 808 Fencing | 810 Permanent Traffic Signs and Supports | 813 Slope Protection | 814 Paved Ditches | 819 Electrical and Lighting | |
| 401 Pipe Culverts | 402 Storm Sewers | | | | | | | | | | | | | | | | | | | | | | | | | | | | |
| 403 Drainage Structures | 602 Concrete Pavement Construction | | | | | | | | | | | | | | | | | | | | | | | | | | | | |
| 603 Concrete Pavement Restoration | 705 Foundation Piling | | | | | | | | | | | | | | | | | | | | | | | | | | | | |
| 706 Structural Concrete Construction | 711 Bridge Railings | | | | | | | | | | | | | | | | | | | | | | | | | | | | |
| 712 Bridge Rehabilitation-Concrete | 713 Bridge Rehabilitation-Steel | | | | | | | | | | | | | | | | | | | | | | | | | | | | |
| 718 Drilled Shafts | 801 Concrete Driveways | | | | | | | | | | | | | | | | | | | | | | | | | | | | |
| 802 Concrete Curb, Gutter and Dividers | 803 Concrete Sidewalk, Sidewalk Ramps, and Steps | | | | | | | | | | | | | | | | | | | | | | | | | | | | |
| 804 Concrete Barriers and Glare Screens | 806 Shared Use Paths | | | | | | | | | | | | | | | | | | | | | | | | | | | | |
| 808 Fencing | 810 Permanent Traffic Signs and Supports | | | | | | | | | | | | | | | | | | | | | | | | | | | | |
| 813 Slope Protection | 814 Paved Ditches | | | | | | | | | | | | | | | | | | | | | | | | | | | | |
| 819 Electrical and Lighting | | | | | | | | | | | | | | | | | | | | | | | | | | | | | |

A. Alkali-Silica Reactivity. Provide documentation to the Engineer that the concrete mixture does not present the potential for deleterious expansion caused by alkali-silica reactivity (ASR). Provide current ASR test results (valid for 2 years from completion of testing), for the fine aggregate that is proposed to be used in the concrete, from an independent testing laboratory proficient in ASR testing. The independent testing laboratory must certify in writing, including a signed statement that all testing was conducted in accordance with the designated standard test procedures, described herein. Test results must conform to the specified criterion for one of the following standard test methods. ASR testing is not required for concrete pavement repairs and temporary concrete pavements. Use the Rounding Method described in *ASTM E 29* when determining significant digits for reporting expansion test results.

(1) Method 1. *ASTM C 1293*. Concrete Prism Test. If the expansion of concrete prisms is not greater than 0.040 percent (rounded to the nearest 0.001 percent) after 1 year, the fine aggregate is considered non-deleterious to ASR and may be used in the JMF.

(2) Method 2. *ASTM C 1567*. Mortar Bar Test. If no previous test data are available for the fine aggregate that shows it is resistant to ASR using Method 1, above, replace 25 to 40 percent of the Portland cement in the concrete mixture with a supplementary cementitious material. A blended cement meeting the requirements of *ASTM C 595* containing the above Portland cement and supplementary cementitious material proportions may also be used.

Demonstrate the ability of the supplementary cementitious material to control the deleterious expansion caused by ASR by molding and testing mortar bars according to the standard test method described in *ASTM C 1567* using the mix proportions and constituent sources for both the aggregates and the cementitious materials that will be used for the project. Make at least three test specimens for each cementitious materials-aggregate combination. If the average of three mortar bars for a given cementitious materials-aggregate combination produces an expansion less than 0.10 percent (rounded to the nearest 0.01 percent) at 14 days of immersion, the JMF associated with that combination will be considered non-deleterious to ASR. If the average expansion is 0.10 percent (rounded to the nearest 0.01 percent) or greater, the JMF associated with that combination will be considered not sufficient to control the deleterious expansion caused by ASR and the JMF will be rejected.

(3) Method 3. *ASTM C 1260*. Mortar Bar Test. If the expansion of the mortar bars is less than 0.10 percent (rounded to the nearest 0.01 percent) at 14 days of immersion, the fine aggregate is considered non-deleterious to ASR and may be used in the concrete without the need for ASR mitigation.

The Engineer will not approve the use of the JMF if the expansion exceeds the respective threshold limits for the respective ASTM test method used.

B. Contractor Provided Mixes. Provide mix design and accompanying JMFs using the methods of verification included in this special provision. Include sufficient information on constituent materials and admixtures along with trial batch verified physical properties of the fresh concrete, mix proportions per cubic yard for all constituents and compressive strength test results necessary to allow the Engineer to

fully evaluate the expected performance of the concrete mixture.

(1) Mix Documentation. Prepare mix designs for each grade of concrete required on the project. Submit JMF for each mix design, including all required documentation, to the Engineer for review 10 working days before the anticipated date of placement. The Engineer will notify the Contractor of any objections within 5 working days of receipt of the mix documentation. Number or otherwise identify each JMF and reference all accompanying documentation to this identification. Reference each JMF to the appropriate method of verification. Mix design and JMF submittals that do not include all required documentation will be considered incomplete and the Engineer will return them without review.

Mix documentation for the project is required to be verified annually. The Engineer may allow annual mix documentation renewal if it is shown that the material characteristics have not deviated beyond the requirements specified in the contract.

All mix designs and accompanying JMFs must be traceable to a laboratory meeting the requirements of this special provision.

Submit mix design and JMF on the MDOT Job Mix Formula (JMF) Concrete Field Communication form (MDOT Form Number 1976); include accompanying documentation. List the source of materials, bulk density (unit weight) of coarse aggregate (rodding procedure or shoveling procedure), absorption of aggregates, relative density (specific gravity) of aggregates, aggregate correction factors, batch weights, and project specific or historical laboratory test data. Include the recorded air content of fresh concrete using the same admixture and cementitious material sources to be used in the production of the concrete for the project. A JMF will be approved only if all of the minimum mix design requirements specified in the contract have been met.

(2) Job Mix Formula (JMF). Select proportions for concrete mixtures according to *ACI Standard 211.1*. The volume (oven-dry-rodded) of coarse aggregate per unit volume of concrete must be 65 percent, minimum.

Four methods of verification of proposed JMF are acceptable.

(a) Method 1. Trial Batches. Verification of JMF is based on trial batches with the same materials and proportions proposed for use on the project. Prepare at least one trial batch for each mix design in sufficient time before starting concrete placement to allow for review according to subsection c.5.B.(1) of this special provision. Provide the results of temperature, slump, density (unit weight), air content of fresh concrete, 28-day compressive strength, and age of concrete at the time of strength testing, for a minimum of three independent samples. All samples may be taken from a single trial batch for a mix design provided the trial batch is at least four cubic yards in volume. For JMF trial batch verification purposes only, 7-day compressive strength test results which report at least 70 percent of the specified 28-day lower specification limit (LSL) will be sufficient documentation in lieu of 28-day compressive strengths. The average of at least two strength test specimens represents one compressive strength sample test result for each independent sample. Provide the necessary ASR documentation as described in subsection c.5.A of this special provision.

(b) Method 2. Same Mix. Verification of JMF is based on the concrete producer's experience with the same mix design, JMF, and the same materials. Provide the results of temperature, slump, density (unit weight), air content of fresh concrete, 28-day compressive strength, and age of concrete at the time of strength testing, for a minimum of three independent samples. The average of at least two strength test specimens represents one compressive strength sample test result for each independent sample. Do not substitute material types or sources, including admixtures or cementitious materials, nor change mix proportions in the JMF. Provide the necessary ASR documentation as described in subsection c.5.A of this special provision.

(c) Method 3. Similar Mix. Verification of JMF is based on requirements described in Method 2, in subsection c.5.B.(2).(b) of this special provision. Substitution of coarse aggregate source is permitted if the new source is of the same geologic type as the original aggregate, and conforms to the specification requirements for the application. Substitution of fine aggregate is permitted only if the new source has been tested for ASR. Provide the necessary ASR documentation as described in subsection c.5.A of this special provision.

Provide the supporting laboratory trial batch documentation and accompanying calculations showing how the mix proportions in the JMF were adjusted, based on the documented differences in relative density (specific gravity), bulk density (unit weight) and absorption of the substituted aggregate sources, to produce a theoretical yield of 100 percent and the required fresh concrete properties.

(d) Method 4. Annual Verification. At the Engineer's option, verification may be accepted annually for a concrete producer rather than on a project basis provided the sources and proportions of the constituent materials, including cementitious materials and source and types admixtures, do not change. If the project is the continuation of work in progress during the previous construction season and written certification is submitted to the Engineer that materials from the same source and with the same mixture properties are to be used, the Engineer may waive the requirement for annual renewal verification of the JMF for the project. Provide the necessary ASR documentation as described in subsection c.5.A of this special provision.

C. Department Provided Mixes. Unless otherwise specified in the contract or approved by the Engineer, the Engineer will provide the concrete JMF for the following types of concrete regardless of the total quantity for the project.

- (1) Structural concrete patching mixtures, mortar and grout.
- (2) Bridge deck overlay concrete mixtures.
- (3) Project-specific concrete mixtures and grades not defined in Table 1.

Provide all other mix designs and accompanying JMF's according to subsection c.5.B of this special provision.

The ASR documentation for the fine aggregate described in subsection c.5.A of this

special provision must accompany the Contractor's request for the concrete JMF.

D. Changes in Materials and Proportions. Any changing from one approved JMF to another for the same grade of concrete must have prior approval by the Engineer.

Prior to batching, verify that the proposed JMF changes will not affect the properties of the fresh concrete (slump, temperature, air content, density (unit weight), workability), nor result in deleterious mortar bar expansion as a result of ASR, as described in subsection c.5.A of this special provision.

Record all changes to JMF in the QC records along with the rationale for the change.

E. QC Sampling and Testing. Conduct startup sampling and testing for temperature, slump, density (unit weight), and air content on the first load. Do not place concrete until testing verifies that the fresh concrete properties have not exceeded the QC action and suspension limit thresholds specified in Table 2 and the testing correlation requirements of subsection d.1.B of this special provision have been met. Continue testing subsequent loads as described in the QC plan, for each grade of concrete delivered to the work site each day. The QC sampling and testing must be random and independent from the Agencies QA sampling and testing.

Provide the curing facilities in accordance with subsection d.2.C of this special provision prior to start of concrete production.

Perform QC sampling and testing for air content of fresh concrete that is either slipformed or pumped, as described in the QC plan. Sample and test a representative haul unit of concrete immediately after its discharge but before the slipform paver or pump hopper, where applicable. Sample and test the concrete representing the same haul unit, again, after the slipform paver or after discharge from the pump (without interruption or alteration of the pumping operation), where applicable. If the difference in measured air content between the two test locations for the same concrete is greater than 1.5 percent air by volume of concrete, suspend operations and administer corrective action. Resume concrete placement only after taking the necessary corrective action to reduce the loss in air content of fresh concrete between the two test locations, as approved by the Engineer. Document the corrective action to be taken in the QC records and make the necessary changes to the QC plan, where applicable.

Concrete exceeding the maximum specification limits for slump or temperature must be rejected regardless of the total mixing time at the time of arrival to the project.

The Engineer may require the Contractor to administer additional QC sampling and testing if the Engineer determines the Contractor's current QC sampling and testing methodology is shown to be insufficient to ensure continual control of the quality of the concrete.

Take the appropriate corrective action, as described in the QC plan, when QC testing shows the QC action limits for any quality characteristic are exceeded. Suspend production if any of the QC suspension limits are exceeded or if the corrective action is not sufficient to restore the quality to acceptable levels.

Resume production only after making all necessary adjustments to bring the mixture into

conformance with all applicable specifications and receiving approval to resume work from the Engineer. Document these adjustments in the QC records.

Table 2: QC Action and Suspension Limits

| Quality Characteristic | Action Limits | Suspension Limits |
|--|--------------------------------------|-----------------------------------|
| Air Content (percent) | See Note Below | < 5.0 or > 9.0 |
| Air Content Loss (percent) | As Defined in the Contractor QC plan | Greater than 1.5 |
| Conc. Temp. (Deg. F) | | < 45 or > 90 at time of placement |
| Slump (max.) (inch) | | See Table 1, footnote (g) |
| Density (unit weight) | | N/A |
| Note: Action limits must be defined in the Contractor QC plan and cannot be < 5.5 or > 8.5. Suspend work if air content is < 5.0 or > 9.0 percent after pump or paver, regardless of the air content loss. | | |

F. Work Progress Test Specimens. Determine the strength of concrete for opening to construction traffic or regular traffic, for removing shoring and forms, or for similar purposes in accordance with subsections 104.11, 601.03.H and 701.03.D of the Standard Specifications for Construction, and as approved by the Engineer. Cure work progress test specimens in the same manner as the in-situ concrete. Allow the Engineer to witness testing of work progress test specimens.

The maturity method may be used to determine the in-place, opening-to-traffic flexural strength, provided the necessary preliminary flexural strength versus time-temperature factor correlation, using the same materials and JMF, is established according to Department procedures and approved by the Engineer before placing the concrete.

G. Reduced QC for Small Incidental Quantities. If approved by the Engineer, reduced levels of on-site QC testing for concrete may be considered for small incidental quantities defined in subsection a.1 of this special provision.

Unless approved by the Engineer, multiple small incidental quantities, including ones that are consecutively placed throughout the project on the same day, are not eligible for reduced QC consideration if the total plan quantity of concrete for the item exceeds 100 cubic yards in volume. Include details for reduced QC testing and oversight in the approved QC plan, and in accordance with following:

- (1) The small incidental quantity of concrete will be limited to a single day's concrete placement of a maximum 20 cubic yards in volume.
- (2) The small incidental quantity of concrete is not an integral part of a structural load bearing element.
- (3) The Engineer received written certification from the Contractor that the concrete supplier has a current QC plan in place and available for review upon request by the Engineer.
- (4) The concrete supplier employs a certified concrete technician (MCA Michigan Level II) available at the plant or on call during concrete placement to validate and authorize modifications to the concrete JMF, as necessary.
- (5) Prior to the first concreting operation, concrete representing the JMF for the small incidental quantity has been sampled and tested by a certified concrete

technician (MCA Michigan Level I or II) to verify that, historically, the JMF produced a concrete mixture meeting the minimum requirements for density (unit weight), slump, air content, and strength. Annual verification may be acceptable provided there are no changes to the material types or sources, including the cementitious materials and admixtures.

(6) The Engineer verified that the temperature, slump, and air content conform to specification requirements at the start of the day's concreting operation associated with the small incidental quantity.

(7) The Engineer is notified and provided sufficient opportunity to witness concrete placement.

d. Department Administered Quality Assurance (Acceptance).

1. Department Quality Assurance Plan (QA plan). The Engineer will be responsible for administering the quality-based acceptance and will institute any actions necessary toward its successful implementation.

Acceptance of concrete pavement repair mixtures and concrete mixtures not included in Table 1 will be in accordance with the contract.

The Engineer will develop and follow a QA plan. The Engineer will provide the QA plan to the QC Plan Administrator a minimum of 5 working days prior to the pre-production meeting. The QA plan will be reviewed at the pre-production meeting and any proposed changes will be documented.

The nominal QA strength test specimen size, defined in subsection a.1 of this special provision will be noted in the QA plan.

A. Personnel Requirements. The personnel responsible for field inspection and for obtaining QA samples will possess the required qualifications to collect QA samples. Sampling will be performed by a certified concrete technician (MCA Michigan Level I or II) or (MCAT) certified aggregate technician, where applicable.

B. Testing Correlation. Prior to initial concrete placement, the testing personnel for both the Engineer's QA and Contractor's QC will use the equipment they have assigned to the project to conduct side by side correlation testing of the same concrete used on the project to verify correlation of both the Department's and the Contractor's test results for temperature and air content of fresh concrete. Additional side by side correlation testing will be conducted whenever there is a change in QC or QA equipment and/or testing personnel for the project, or as directed by the Engineer. The temperature measuring devices used for QC and QA must correlate with each other within 2 degrees F. If the air content results of the side by side tests conducted by the QC and QA testers and equipment differ by more than 0.8 percent air by volume of concrete, a referee air content test of fresh concrete must be conducted by a third party, designated by the Engineer but independent of the project, prior to commencement or continuation of concrete placement in efforts to resolve issues associated with non-correlation.

C. Laboratory Facilities. The testing laboratory with responsibility for acceptance testing on this project is the Department testing laboratory, or a qualified facility under the

authority of the Engineer.

2. QA Sampling and Testing. The Engineer will verify the Contractor's daily startup sampling and testing of temperature, slump, and air content of fresh concrete on the first load; conduct QA sampling and testing; monitor Contractor adherence to the QC plan; and inspect field placed materials in such a manner as to ensure that all concrete for the project is represented. The testing correlation requirements of subsection d.1.B of this special provision must be met prior to concrete placement.

The following *ASTM* test methods will apply. The Department's established procedures for sampling and testing are acceptable alternatives.

C 31 Practice for Making and Curing Concrete Test Specimens in the Field

C 39 Test Method for Compressive Strength of Cylindrical Concrete Specimens

C 78 Test Method for Flexural Strength of Concrete (Using Simple Beam with Third-Point Loading)

C 138 Test Method for Density (Unit Weight), Yield and Air Content (Gravimetric) of Concrete

C 143 Test Method for Slump of Hydraulic-Cement Concrete

C 172 Practice for Sampling Freshly Mixed Concrete

C 173 Test Method for Air Content of Freshly Mixed Concrete by the Volumetric Method

C 231 Test Method for Air Content of Freshly Mixed Concrete by the Pressure Method

C 293 Test Method for Flexural Strength of Concrete (Using Simple Beam with Center-Point Loading)

A. Lot Size and Make Up. A production lot will not include more than one grade of concrete, concrete of the same grade having different specified slump or air content, or concrete of the same grade having different mix designs, or JMFs. Lot size and makeup will be determined by the Engineer, based on site conditions. A production lot may consist of a single day's production, individual concrete structural elements (eg. footing, column, pier cap, deck, bridge approach slab), or any combination thereof, provided they are of the same JMF. Each production lot will be divided into sublots of approximately equal size, as determined by the Engineer. The minimum number of sublots will be one per production lot, with the maximum number of sublots based on the anticipated total quantity of concrete to be placed and site conditions. A minimum of one sublot will be required for each day of production.

B. Sampling. QA sampling and testing will be conducted by the Engineer during concrete placement. Where practical, the random number method (as described in the "Random Sampling for Quality Control/Quality Assurance Projects" section of the Materials Quality Assurance Procedures Manual) will be used to determine the sampling locations. The sampling rate will be determined by the Engineer, based on the anticipated total quantity of concrete to be placed and site conditions, with a minimum of one sampling for each day of production.

At the option of the Engineer, small incidental quantities as defined in subsection a.1 of this special provision may be accepted (visually inspected and noted on the Inspector's Daily Report) without daily 28-day compressive strength QA test specimens provided there is a current acceptable strength test history of the JMF for the project prior to placement of the small incidental quantity. One set of compressive strength QA test specimens will then be molded for each small incidental quantity JMF at least once per week during production, thereafter, as determined by the Engineer (note the test results or identification number for the corresponding weekly QA compressive strength test result on the Inspector's Daily Report for each small incidental quantity). Quality control testing and daily QA testing for temperature, slump, and air content of fresh concrete are still required. Reduced QC for small incidental quantities, as described in subsection c.5.G of this special provision, may be considered.

The QA sampling rate and sample location will be based on cubic yard quantities.

Samples for acceptance will be taken at the point of discharge from the haul unit, at approximately the middle one-third of the load. Mix adjustments to the concrete contained within the haul unit selected for QA sampling and testing (beyond normal QC) will not be permitted prior to QA sampling and testing. QA sampling will be random and without prior notification.

The Engineer will perform QA sampling and testing for air content loss of fresh concrete that is either slipformed or pumped, (1) at least once during each day of production, (2) whenever the concrete pump is relocated, where applicable, or (3) whenever there is a significant change in the boom configuration or operation of the concrete pump, or there is a significant change in the characteristics of the paving operation during concrete placement. Concrete will be sampled from a representative haul unit immediately after its discharge but before the slipform paver or pump hopper, where applicable. The concrete representing the same haul unit will then be sampled and tested after the slipform paver or after discharge from the pump (without interruption or alteration of the pumping operation), where applicable. If the difference in measured air content between the two test locations for the same concrete is greater than 1.5 percent air by volume of concrete, the Engineer will issue a Notice of Non-Compliance with Contract Requirements (Form 1165), as described in subsection d.2.D of this special provision. The Contractor may resume concrete placement only after the necessary corrective action is taken to reduce the loss in air content of fresh concrete between the two test locations, as approved by the Engineer. Document the corrective action that was taken by the Contractor.

C. Testing. The location(s) within the project limits for QA testing of the fresh concrete and placement of curing facilities for initial curing of the 28-day compressive strength QA test cylinders will be determined by the Engineer in conformance with the following criteria:

- (1) The elapsed time between obtaining the first and the final portion of the composite sample must not exceed 15 minutes.
- (2) Testing for slump, temperature, and air content of fresh concrete must begin within 5 minutes after obtaining the final portion of the composite sample.
- (3) Molding of the 28-day compressive strength QA test cylinders must begin within 15 minutes after obtaining the final portion of the composite sample.

(4) The concrete sample must be protected from the sun, wind, and other sources of rapid evaporation, and from contamination.

Two QA concrete strength test specimens per sample will be molded for 28-day compressive strength QA testing.

The Contractor will provide curing facilities equipped to ensure the proper environment for the Agencies QA concrete strength test specimens during initial cure. Each initial cure facility must provide ventilation or insulation, where applicable, to ensure the ambient temperature surrounding the specimens is maintained according to *AASHTO T23/ASTM C 31*. Failure by the Contractor to maintain the proper curing environment during initial cure will not be basis for rejection of samples or claims against the Department. Each initial curing facility must be capable of being locked, using an Department provided padlock. The Contractor will ensure that all initial curing facilities are accounted for at all time, and protected against theft and damage. The Contractor will place and secure each initial cure facility throughout the project limits in such a manner so as to minimize excessive transport of the test specimens prior to initial cure, as follows:

(5) Immediately after finishing molded specimens, the Engineer will move the QA concrete strength test specimens to the closest initial cure facility provided by the Contractor.

(6) Immediately after all QA concrete strength test specimens are placed into the cure facility and the proper initial curing conditions have been established, the Engineer will secure the facility using the Department provided padlock. Access to the QA concrete strength test specimens, thereafter, must be coordinated with the Engineer and will only be permitted in the presence of the Engineer.

(7) The Engineer will transport the QA concrete strength test specimens within 48 hours after molding, but not prior to 8 hours after final set of the concrete, from the initial curing facility to the Department's designated testing laboratory for final curing and strength testing. The specimens will be protected with a suitable cushioning material to prevent damage from jarring during transport. The total transportation time must not exceed 4 hours prior to commencement of final curing.

D. QA Stop Production Criteria. The Engineer will issue a Notice of Non-Compliance with Contract Requirements (Form 1165) and concrete production must stop when one or more of the following are observed.

(1) The QA testing shows that one or more of the suspension limits for quality characteristics defined in Table 2 are in non-compliance.

(2) The QC plan is not being followed.

(3) Segregation, excessive slumping of unsupported slipformed edges, or other notable changes in the fresh concrete properties is observed that may prevent proper placement, consolidation and finishing, or compromise the performance or long-term durability of the finished product.

(4) The required curing system is not being applied in a timely manner, as

specified by the contract.

(5) If the measured air content loss between the two testing locations for the same concrete is greater than 1.5 percent air by volume of concrete as described in subsections c.5.E and d.2.B of this special provision.

(6) If the air content of fresh concrete is less than 5.0 or greater than 9.0 percent after pump or paver, regardless of the recorded QC or QA air content loss through the pump or paver.

The Engineer will issue a Notice to Resume Work (Form 1165) only after all necessary adjustments are made to restore conformance with all applicable specifications, and the appropriate documentation is made in the QC records.

E. QA Records. The Engineer will maintain a complete record of all QA tests and inspections. The records will contain, as a minimum, signed originals of all QA test results and raw data, random numbers used (where applicable) and resulting calculations. The QA test results will not be provided to the Contractor until the corresponding QC test results are received by the Engineer.

3. Quality Index Analysis. The Engineer's QA test results will be used to determine the pay factor (PF) and price adjustment (ADJ). The Contractor's QC test results will not be used for pay factor and price adjustment analysis. The Engineer will complete pay factor and price adjustment analysis within 7 working days after completion of all 28-day compressive strength testing for the representative production lot or quantity of concrete. The quality index parameter specification limits are defined in Table 3. Unless otherwise specified in the contract, concrete not conforming to the requirements specified in Table 3 is rejectable and subject to further evaluation. All values of PF and OLPF in these formulae are decimal, not percent. All values of PF and OLPF are rounded to two decimal places.

Price adjustment for 28-day compressive strength deficiencies will be based on test results for the corresponding weekly QA test specimens and the pay factor (PFs) calculated according to the formula defined in subsection d.3.A. The price adjustment (ADJ) = (PFs – 1)(Price).

Table 3: Quality Index Parameter Specification Limits

| Quality Characteristic | Specification Limits |
|--|------------------------------|
| Air Content of Fresh Concrete (percent) | 5.5 – 8.5 |
| Rejection Limit (percent) | <5.0 or >9.0 |
| Conc. Temp. (deg. F) | 45 - 90 at time of placement |
| Slump (max.) (inch) | See Table 1, footnote (g) |
| 28-day Compressive Strength (psi) | For LSL see Table 1 |
| Rejection Limit - 28-day Compressive Strength | See Table 1 |

A. Pay Factor for 28-Day Compressive Strength (PFs).

$$PFs = \frac{\text{Tested Strength}}{\text{LSL}}$$

Where:

PFs = Pay Factor for 28-day compressive strength (not to exceed 1.00)

Tested Strength = QA 28-day compressive strength sample test result

LSL = Lower specification limit (see Table 1)

If the tested strength does not meet the rejection limit specified in Table 1, the Engineer will require additional evaluation as described in subsection d.4 of this special provision.

B. Pay Factor for Air Content of Fresh Concrete (PFac). The pay factor for air content of fresh concrete (PFac) will be according to Table 4.

Table 4: Air Content of Fresh Concrete Pay Factor (PFac)

| Air Content of Fresh Concrete (percent) | Pay Factor (PFac) |
|---|-------------------|
| 5.5 – 8.5 | 1.00 |
| 5.0 – 5.4 | 0.50 |
| Below 5.0 | Rejection |
| 8.6 – 9.0 | 0.75 |
| Above 9.0 | Rejection |

If the air content of fresh concrete is below 5.0 or above 9.0 percent, the Engineer will elect to do one of the following.

(1) Require removal and replacement of the entire quantity of concrete represented by the test with new testing conducted on the replacement concrete and repeat the evaluation procedure.

(2) Allow submittal of a corrective action plan for the Engineer's approval. If the Engineer does not approve the plan for corrective action, subsection d.3.B.(1) of this special provision will be applied. All costs associated with plan submittal and corrective action under this subsection will be borne by the Contractor.

C. Overall Lot Pay Factor (OLPF). The following formulae are used to calculate the OLPF and ADJ. The OLPF will not exceed 1.00.

$$\text{OLPF} = (0.60 \times \text{PFs}) + (0.40 \times \text{PFac})$$

$$\text{ADJ} = (\text{OLPF} - 1)(\text{Price})$$

ADJ = Price adjustment per pay unit to be applied to the quantity represented by the QA test

Price = Base price established for the pay item

4. Evaluation of Rejectable Concrete. The Engineer will require additional evaluation to decide what further action may be warranted, as described below. Acceptance for air content of fresh concrete will be based on QA test results reported at the time of concrete placement.

If the Engineer determines that non-destructive testing (NDT) is appropriate, this work will be done by the Contractor in the presence of the Engineer within 45 calendar days from concrete placement. All costs associated with this work will be borne by the Contractor. A complete set of non-destructive tests must be conducted (in accordance with the respective standard test method) at a minimum three randomly selected locations. If NDT is used to estimate the in-situ strength, a calibrated relationship between the project JMF under evaluation and the NDT apparatus must have been established prior to NDT testing according to its respective standard test method.

If the 28-day compressive strength QA test results show that the rejection limit (as specified in Table 1) has not been achieved, the quantity of concrete under evaluation will be rejected and the Engineer will require additional evaluation to decide what further action may be warranted.

Propose an evaluation plan and submit it to the Engineer for approval before proceeding. The results from NDT will be used only to decide what further action is required. This determination will be made by the Engineer, as follows:

A. For non-structural concrete. If no test result from non-destructive testing falls below the lower specification (LSL) 28-day compressive strength, the represented quantity of concrete under evaluation will remain in place and a pay factor for 28-day compressive strength (PFs) of 1.00 will be applied for overall lot pay factor (OLPF) and price adjustment (ADJ) determinations according to subsection d.3 of this special provision.

B. For structural concrete (including overhead sign foundations). If no test result from non-destructive testing falls below the lower specification limit 28-day compressive strength, the represented quantity of concrete under evaluation will remain in place and a pay factor for 28-day compressive strength (PFs) of 0.85 will be applied for overall lot pay factor (OLPF) and price adjustment (ADJ) determinations according to subsection d.3 of this special provision.

C. If one or more of the non-destructive test results fall below the lower specification limit (LSL) 28-day compressive strength, the Engineer may elect to do one of the following:

(1) Require removal and replacement of the entire rejected quantity of concrete, including new initial tests for pay factor (PF) determination and price adjustment conducted according to subsection d.3 of this special provision.

(2) Allow the Contractor to submit a plan for corrective action, for the Engineer's approval, to address the disposition of the rejected concrete. If the Engineer does not approve the plan for corrective action, subsection d.4.C.(1) of this special provision will be applied. All costs associated with plan submittal and corrective action under this subsection will be borne by the Contractor.

(3) Allow the in-situ quantity of concrete under evaluation to remain in place and a pay factor (PFs) of 0.50 will be applied for overall lot pay factor (OLPF) and price adjustment (ADJ) determinations according to subsection d.3 of this special provision.

e. Measurement and Payment. If a price adjustment is made for reasons included in this special provision, that adjustment will be made using the base price established for the specific item. If a contract unit price requires adjustment for other reasons not described in this special

provision, the adjustments will be made using the unit price and the adjustments will be cumulative.

Separate payment will not be made for providing, implementing, and maintaining an effective QC program. All costs associated with this work will be included in the applicable unit prices for the concrete items. Failure by the Contractor to maintain the proper curing environment during initial cure will not be basis for claim against the Department.

All costs associated with providing, locating, relocating, maintaining, and securing the adequate number of portable initial curing facilities for both the QC and QA strength test specimens will be included in the applicable unit prices for the concrete items. No additional payment will be permitted. The Contractor is responsible for damage, theft, subsequent replacement, and removal after completion of the work for each curing facility used on the project.

APPENDIX A

EXHIBITS AND LOCATION MAPS

Exhibit 1

TREE ROOT REMOVAL

THE CONTRACTOR SHALL REMOVE ALL TREE ROOTS WHICH CONFLICT WITH THE PROPOSED CONSTRUCTION OF REPLACEMENT SIDEWALKS. TREE ROOTS REMOVED SHALL BE DISPOSED OF BY THE CONTRACTOR IN ACCORDANCE WITH THE CONTRACT REQUIREMENTS. REMOVAL OF TREE ROOTS SHALL BE PAID FOR AS "ROOT/STUMP REMOVAL, EA"

RESTORATION

RESTORATION OF DISTURBED AREAS SHALL CONSIST OF, BUT NOT BE LIMITED TO, PROVIDING ALL LABOR, MATERIALS, AND EQUIPMENT NECESSARY FOR THE PREPARATION OF ALL AREAS TO BE RESTORED WITH 2" TOPSOIL, CLASS A SEED AND MULCH. RESTORATION OF DISTURBED AREAS SHALL BE CONSIDERED INCIDENTAL TO THE CONSTRUCTION ITEM.

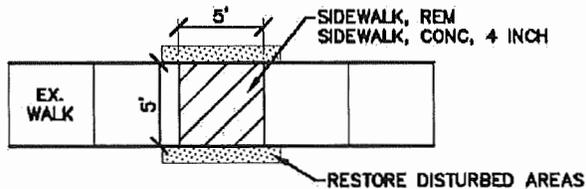

SAWCUTTING

THE WORK OF PROVIDING FULL DEPTH SAWCUTTING OF PAVEMENTS SHALL NOT BE PAID FOR SEPARATELY BUT SHALL BE CONSIDERED INCIDENTAL TO THE APPROPRIATE CONSTRUCTION ITEM AS DIRECTED BY THE ENGINEER.

4" CONCRETE SIDEWALK REMOVAL AND REPLACEMENT DETAIL

N.T.S.

Exhibit 2

TREE ROOT REMOVAL

THE CONTRACTOR SHALL REMOVE ALL TREE ROOTS WHICH CONFLICT WITH THE PROPOSED CONSTRUCTION OF REPLACEMENT SIDEWALKS. TREE ROOTS REMOVED SHALL BE DISPOSED OF BY THE CONTRACTOR IN ACCORDANCE WITH THE CONTRACT REQUIREMENTS. REMOVAL OF TREE ROOTS SHALL BE PAID FOR AS "ROOT/STUMP REMOVAL, EA"/M

RESTORATION

RESTORATION OF DISTURBED AREAS SHALL CONSIST OF, BUT NOT BE LIMITED TO, PROVIDING ALL LABOR, MATERIALS, AND EQUIPMENT NECESSARY FOR THE PREPARATION OF ALL AREAS TO BE RESTORED WITH 2" TOPSOIL, CLASS A SEED AND MULCH. RESTORATION OF DISTURBED AREAS SHALL BE CONSIDERED INCIDENTAL TO THE CONSTRUCTION ITEM.

SAWCUTTING

THE WORK OF PROVIDING FULL DEPTH SAWCUTTING OF PAVEMENTS SHALL NOT BE PAID FOR SEPARATELY BUT SHALL BE CONSIDERED INCIDENTAL TO THE APPROPRIATE CONSTRUCTION ITEM AS DIRECTED BY THE ENGINEER.

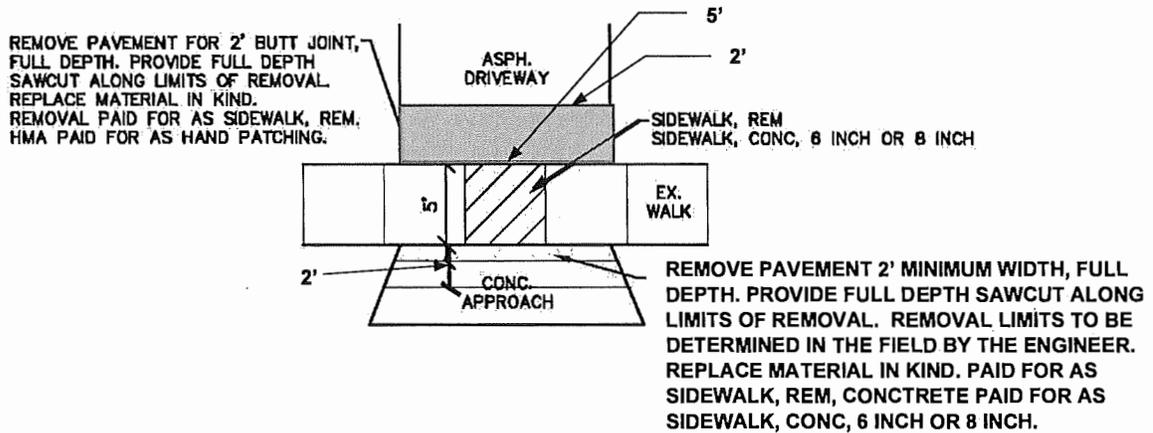

6" OR 8" CONCRETE SIDEWALK REMOVAL AND REPLACEMENT DETAIL

N.T.S.

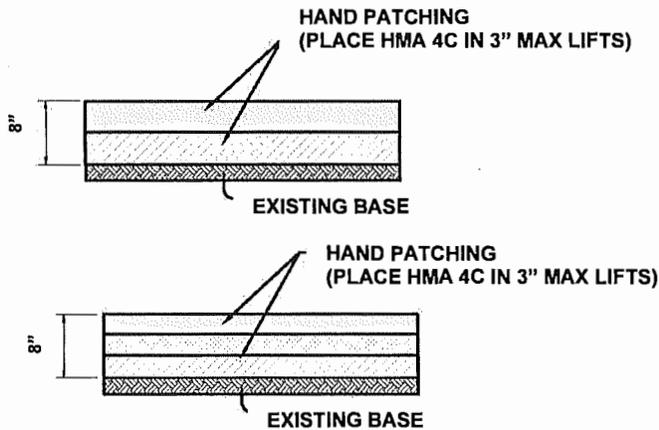

HAND PATCHING BUTT JOINT DETAIL

N.T.S.

Exhibit 3

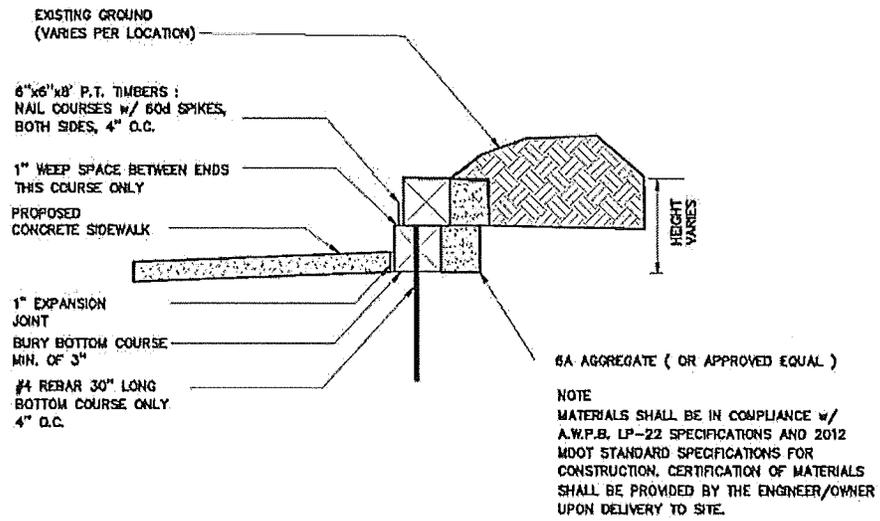

TIMBER RETAINING WALL DETAIL

N.T.S.

Exhibit 4
2021 CDBG SIDEWALK IMPROVEMENT PROGRAM
OVERALL LOCATION MAP

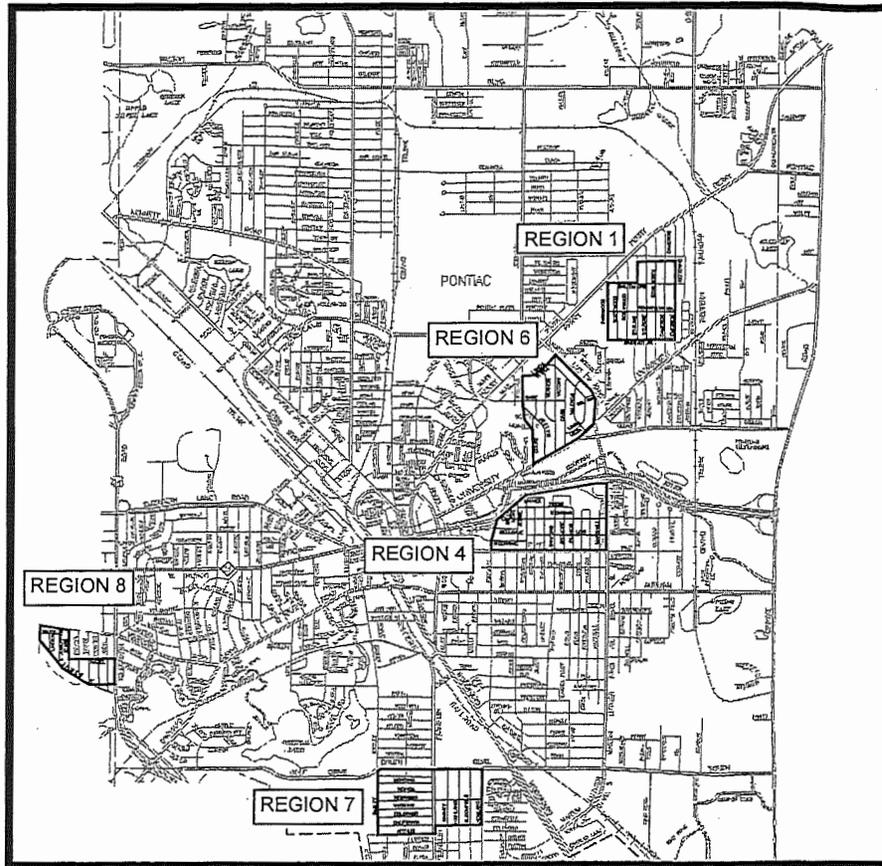

PREPARED FOR:

CITY OF PONTIAC
2021 CDBG SIDEWALK
IMPROVEMENT PROGRAM

| | | | |
|-------|----------|-------|---------|
| SCALE | DATE | DRAWN | JOB NO. |
| NTS | 04-12-21 | JAC | M309 |

NF
ENGINEERS
NOWAK & FRAUS ENGINEERS
46777 WOODWARD AVE.
PONTIAC, MI 48342-5032
TEL. (248) 332-7931
FAX. (248) 332-8257

Exhibit 6

REGION 4 SIDEWALK IMPROVEMENTS

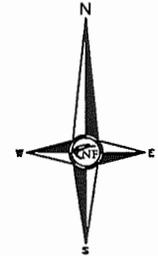
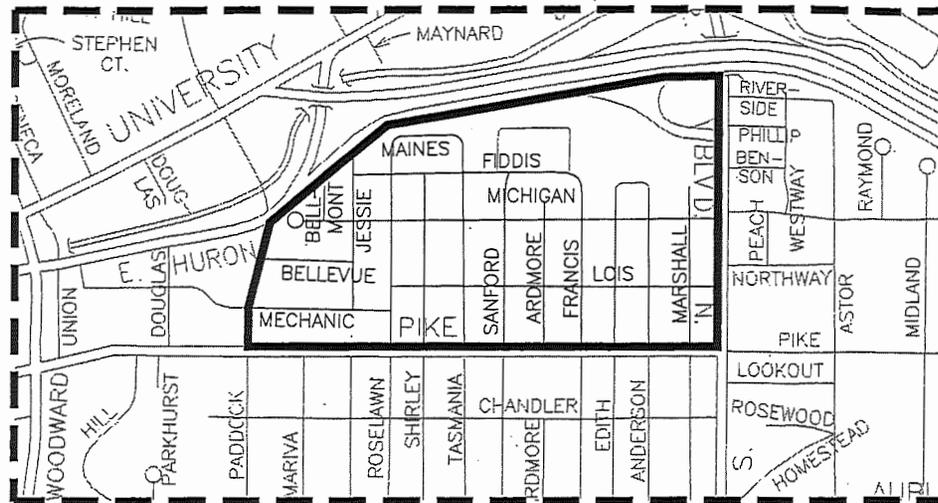

STREETS INCLUDED FOR REGION 4:

| | | |
|---------------|----------------------|-----------------|
| MAINES ST.. | BELMONT AVE. | N. ARDMORE ST. |
| FIDDIS AVE. | JESSIE/N. JESSIE ST. | N. FRANCIS ST. |
| MICHIGAN AVE. | N. ROSELAWN ST. | N. EDITH ST. |
| LOIS LN. | N. SHIRLEY ST. | N. ANDERSON ST. |
| BELLEVUE ST. | N. TASMANIA ST. | N. MARSHALL ST. |
| MECHANIC ST. | N. SANFORD ST.. | |

PREPARED FOR:
CITY OF PONTIAC
2021 CDBG SIDEWALK
IMPROVEMENT PROGRAM

SCALE DATE DRAWN JOB NO.
NTS 04-12-21 JAC M309



ENGINEERS
NOWAK & FRAUS ENGINEERS
46777 WOODWARD AVE.
PONTIAC, MI 48342-5032
TEL (248) 332-7931
FAX. (248) 332-8257

Exhibit 7

REGION 6 SIDEWALK IMPROVEMENTS

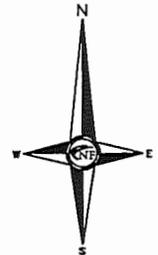
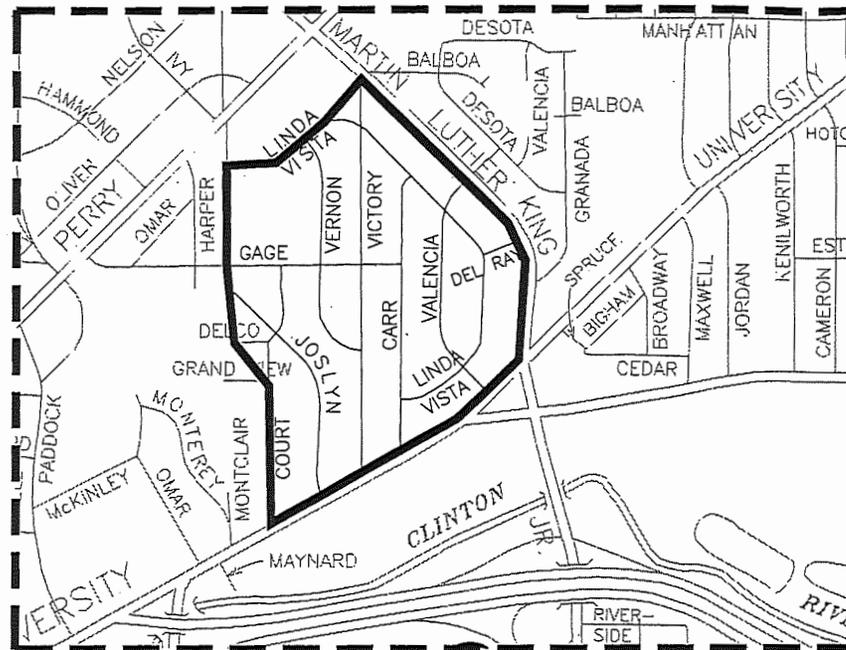

STREETS INCLUDED FOR REGION 6:

- | | |
|-----------------|--------------|
| LINDA VISTA DR. | VICTORY DR. |
| JOSLYN AVE. | CARR ST. |
| GAGE ST. | VALENCIA DR. |
| VERNON DR. | DEL RAY DR. |
| | COURT ST. |

PREPARED FOR:
 CITY OF PONTIAC
 2021 CDBG SIDEWALK
 IMPROVEMENT PROGRAM

| | | | |
|-------|----------|-------|---------|
| SCALE | DATE | DRAWN | JOB NO. |
| NTS | 04-12-21 | JAC | M309 |

NF
ENGINEERS
 NOWAK & FRAUS ENGINEERS
 46777 WOODWARD AVE.
 PONTIAC, MI 48342-5032
 TEL (248) 332-7931
 FAX (248) 332-8257

Exhibit 8

REGION 7 SIDEWALK IMPROVEMENTS

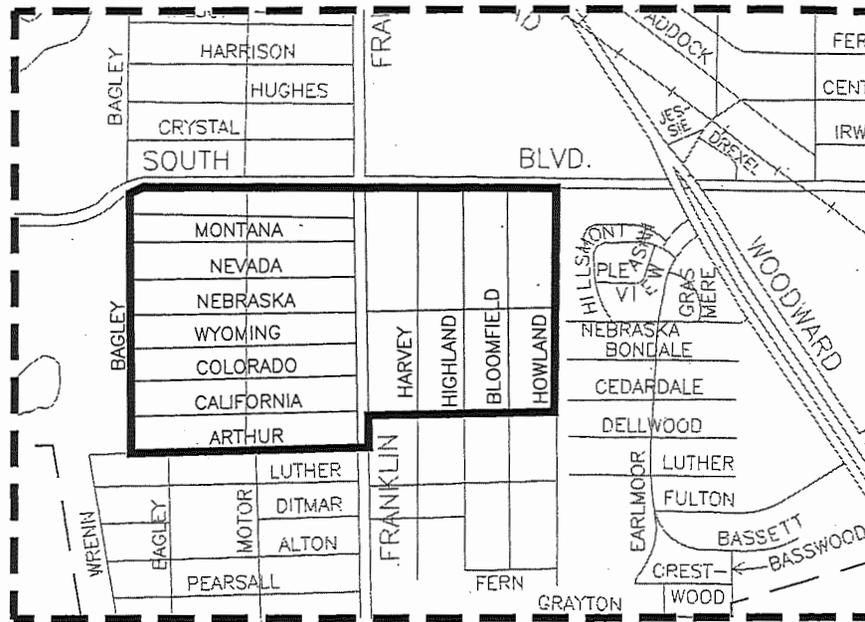

STREETS INCLUDED FOR REGION 7:

- | | |
|---------------|-----------------|
| MONTANA AVE. | ARTHUR AVE. |
| NEVEDA AVE. | HARVEY AVE. |
| NEBRASKA AVE. | HIGHLAND AVE. |
| WYOMING AVE. | BLOOMFIELD AVE. |
| COLORADO AVE. | HOWLAND AVE. |

PREPARED FOR:
 CITY OF PONTIAC
 2021 CDBG SIDEWALK
 IMPROVEMENT PROGRAM

SCALE DATE DRAWN JOB NO.
 NTS 04-12-21 JAC M309



ENGINEERS
 NOWAK & FRAUS ENGINEERS
 4677 WOODWARD AVE.
 PONTIAC, MI 48342-5032
 TEL (248) 332-7931
 FAX (248) 332-8257

Exhibit 9

REGION 8 SIDEWALK IMPROVEMENTS

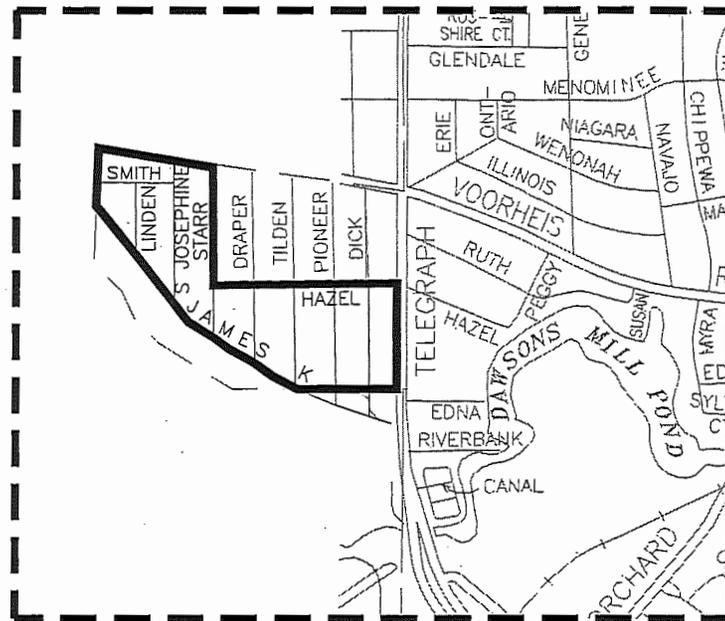

STREETS INCLUDED FOR REGION 8:

- | | |
|---------------|---------------|
| JAMES K BLVD. | S. TILDEN ST. |
| HAZEL AVE. | DRAPER AVE. |
| DICK AVE. | STARR AVE. |
| PIONEER AVE. | LINDEN RD. |
| | SMITH DR. |

PREPARED FOR:
 CITY OF PONTIAC
 2021 CDBG SIDEWALK
 IMPROVEMENT PROGRAM

SCALE DATE DRAWN JOB NO.
 NTS 04-12-21 JAC M309

NF
ENGINEERS
 NOWAK & FRAUS ENGINEERS
 4677 WOODWARD AVE.
 PONTIAC, MI 48342-5032
 TEL (248) 332-7931
 FAX (248) 332-8257

Exhibit 10

Citywide List of Sidewalk Complaint Repairs

206 West Rundell

295 West Huron

33 Niagra

174 Euclid

204 O'Riley

275 South Josephine

65 East Princeton

20 North Anderson

24 North Anderson

25 North Anderson

29 North Anderson

33 North Anderson

37 North Anderson

509 Alton

263 Chandler

71 South Shirley

593 Ditmar

452 Lynch

The City of Pontiac reserves the right to increase or decrease the City-Wide Sidewalk Repair Locations as it deems in the best interest of the City. There will be no adjustments to unit prices in the event of increase, decrease or deletions.

APPENDIX B

EMPLOYEE RIGHTS UNDER THE DAVIS-BACON ACT

FOR LABORERS AND MECHANICS EMPLOYED ON FEDERAL OR FEDERALLY ASSISTED CONSTRUCTION PROJECTS

THE UNITED STATES DEPARTMENT OF LABOR WAGE AND HOUR DIVISION

PREVAILING WAGES

You must be paid not less than the wage rate listed in the Davis-Bacon Wage Decision posted with this Notice for the work you perform.

OVERTIME

You must be paid not less than one and one-half times your basic rate of pay for all hours worked over 40 in a work week. There are few exceptions.

ENFORCEMENT

Contract payments can be withheld to ensure workers receive wages and overtime pay due, and liquidated damages may apply if overtime pay requirements are not met. Davis-Bacon contract clauses allow contract termination and debarment of contractors from future federal contracts for up to three years. A contractor who falsifies certified payroll records or induces wage kickbacks may be subject to civil or criminal prosecution, fines and/or imprisonment.

APPRENTICES

Apprentice rates apply only to apprentices properly registered under approved Federal or State apprenticeship programs.

PROPER PAY

If you do not receive proper pay, or require further information on the applicable wages, contact the Contracting Officer listed below:

| | |
|---|--|
| <p>L. BROOKS PATTERSON Oakland County Executive</p>  <p>Mike Pucher Supervisor, Contract Compliance Unit</p> <p>COMMUNITY & HOME IMPROVEMENT DIVISION</p> | <p>Oakland Pointe, Ste. 1900 250 Elizabeth Lk. Rd. Pontiac, MI 48341-0714 Tel (248) 858-0196 Fax (248) 858-5311 Toll Free (888) 350-0900 x-80196 pucherm@oakgov.com www.oakgov.com/chi</p> |
|---|--|

or contact the U.S. Department of Labor's Wage and Hour Division.



For additional information:

1-866-4-USWAGE

(1-866-487-9243) TTY: 1-877-889-5627



WWW.WAGEHOUR.DOL.GOV

Agreement of Prime Contractor

WE HEREBY AGREE, and will require companies awarded subcontracts for this project to agree, to conform to the policy that during the performance of this contract:

1. We will not discriminate against any subcontractor, employee or applicant for employment because of race, creed, color, age, national origin, sex, height, weight, marital status or handicap as provided in Section 3 (A) Act 344, Public Acts of 1965 as amended by Act 349 Public Acts of 1966. We will take affirmative action to insure that applicants are employed, and that employees are treated during employment, without regard to race, creed, color, age, national origin, sex, height, weight, marital status or handicap. This obligation includes, but is not limited to, the following: employment, upgrading, promotion or transfer; recruitment or recruitment advertising, lay-off or termination; rates of pay or other forms of compensation; selection for training, including apprenticeship. We agree to post notices that set forth the provisions of this nondiscrimination clause in conspicuous places, available to employees and applicants for employment, as required and provided by the municipality.
2. We will, in all solicitations or advertisements for employees placed by us or on our behalf, state that all qualified applicants will receive consideration for employment without regard to race, creed, color, age, national origin, sex, height, weight, marital status or handicap.
3. We will send to each labor union or representative or workers with which we have a collective bargaining agreement, or other contract or understanding, a notice, to be provided by the municipality, advising the labor or worker's representative of our commitments under this Contract Compliance Plan and shall post copies of the notice in conspicuous places available to employees and applicants for employment.
4. We will comply with and be bound by: all Ordinance provisions when applicable, Contract Compliance Provisions, and any other provisions included in the Specifications. We shall file, and shall cause each of our subcontractors to file, compliance reports with the municipality within such times and in such forms as the municipality shall prescribe. Compliance reports shall contain such information as that regarding the practices, policies, programs and employment statistics of the prime contractor and each subcontractor.
5. We will permit the municipality, the municipality's auditors, the Oakland County Community Development Division, the Oakland County Auditing Division and/or the U.S. Dept. of Housing and Urban Development access to our books, records and accounts for investigation purposes to ascertain observance of this Contract Compliance Plan.
6. We acknowledge that in the event of noncompliance with the nondiscrimination clauses of this contract, or with any applicable rules, regulations or orders, this contract may be cancelled, terminated, or suspended in whole or in part and that we may be declared ineligible for further municipal contracts in accordance with procedures authorized herein and such other sanctions as may be imposed and remedies involved as provided by ordinance, rule, regulation or as otherwise provided herein or by law.
7. We will include the provisions of paragraphs one through six in every subcontract let under this contract so that these provisions will be binding upon each subcontract, unless otherwise exempted by prior written authorization by the municipality. With respect to any subcontract, we will take such action as the municipality may direct as a means of enforcing such provisions, including sanctions for noncompliance, provided that in the event we are threatened with, or become involved in litigation with a subcontractor or vendor as a result of such direction by the municipality, we may request the municipality to enter into such litigation to protect the interests of the municipality.

General Contractor

Signature

Title

Contractor's Certification
Community Development Block Grant Program
Concerning Labor Standards and Prevailing Wage Requirements

TO: Mike Pucher, Supervisor
 Contract Compliance Unit
 Oakland County Community & Home Improvement
 Oakland Pointe, Ste 1900
 250 Elizabeth Lk. Rd.
 Pontiac Mi 48341-0414

| | |
|---------------|-------------------------|
| PROJECT NAME: | PROJECT NUMBER (if any) |
|---------------|-------------------------|

1. The undersigned, having executed a contract with _____
 in the amount of \$_____ for the construction of the above-identified project, acknowledges that:
 (a) The Federal Labor Standards Provisions are included in the aforesaid contract.
 (b) Correction of any infractions of the aforesaid conditions, including infractions by any of his subcontractors and
 any lower tier subcontractors, is his responsibility.

2. He certifies that:
 (a) Neither he nor any firm, partnership or association in which he has substantial interest is designated as an ineligible contractor by the Comptroller General of the United States pursuant to Section 5.6(b) of the Regulations of the Secretary of Labor, Part 5 (29 CFR, Part 5) or pursuant to Section 3(a) of the Davis-Bacon Act as amended (40 U.S.C. 276a-2(a)).
 (b) No part of the aforementioned contract has been or will be subcontracted to any subcontractor if such subcontractor or any firm, corporation, partnership or association in which such subcontractor has a substantial interest is designated as an ineligible contractor pursuant to any of the aforementioned regulatory or statutory provisions.

3. He agrees to obtain and forward to the aforementioned recipient within ten days after the execution of any subcontract, including those executed by his subcontractors and any lower tier subcontractors, a Subcontractor's Certification Concerning Labor Standards and Prevailing Wage Requirements executed by the subcontractors.

4. He certifies that:
 (a) Employer's IRS # is: _____
 (b) Legal name and the business address of the undersigned are: _____

(c) The undersigned is (please check one):

| | |
|--|---|
| <input type="checkbox"/> A Single Proprietorship | <input type="checkbox"/> A Corporation Organized in The State of: |
| <input type="checkbox"/> A Partnership | <input type="checkbox"/> Other Organization (Describe) |

(d) Name, title and address of the owner, partners or officers of the undersigned are:

| Name | Title | Address |
|------|-------|---------|
| | | |
| | | |
| | | |
| | | |

(e) The names and addresses of all other persons, both natural and corporate, having a substantial interest in the undersigned, and the nature of the interest are (if none, so state):

| Name | Address | Nature of Interest |
|------|---------|--------------------|
| | | |
| | | |
| | | |
| | | |
| | | |

(f) The names, addresses and trade classifications of all other building construction contractors in which the undersigned has a substantial interest are (if none, so state):

| Name | Address | Trade Classification |
|------|---------|----------------------|
| | | |
| | | |
| | | |
| | | |
| | | |

_____ (Name of Contractor)

By _____ (Authorized Signature)

Date _____

Sub Contractor's Certification
 Community Development Block Grant Program
 Concerning Labor Standards and Prevailing Wage Requirements

TO: Mike Pucher, Supervisor
 Contract Compliance Unit
 Oakland County Community & Home Improvement
 Oakland Pointe, Ste 1900
 250 Elizabeth Lk. Rd.
 Pontiac Mi 48341-0414

| | |
|---------------|--------------------------|
| PROJECT NAME: | PROJECT NUMBER: (if any) |
|---------------|--------------------------|

1. The undersigned, having executed a contract with _____
 for _____ in the amount of \$ _____

in the construction of the above-identified project, certifies that:

(a) The Federal Labor Standards Provisions of the Contract are included in the aforesaid contract.

(b) Neither he nor any firm, corporation, partnership or association in which he has substantial interest is designated as an ineligible contractor by the Comptroller General of the United States pursuant to Section 5.6(b) of the Regulations of the Secretary of Labor, Part 5 (29 CFR, Part 5), or pursuant to Section 3(a) of the Davis-Bacon Act as amended (40 U.S.C. 276a-2(a)).

(c) No part of the aforementioned contract has been or will be subcontracted to any subcontractor if such subcontractor or any firm, corporation, partnership or association in which such subcontractor has a substantial interest is Designated as an ineligible contractor pursuant to any of the aforesaid regulatory or statutory provisions.

2. He agrees to obtain and forward to the contractor, for transmittal to the recipient, within ten days after the execution of any lower subcontract, a Subcontractor's Certification Concerning Labor Standards and Prevailing Wage Requirements executed by the lower tier subcontractor, in duplicate.

(a) The workmen will report for duty on or about _____
(Date)

3. He certifies that:

(a) EMPLOYER IRS # is: _____

(b) Legal name and the business address of the undersigned are: _____

(c) The undersigned is (please check one):

| | |
|--|---|
| <input type="checkbox"/> A Single Proprietorship | <input type="checkbox"/> A Corporation Organized in The State of: |
| <input type="checkbox"/> A Partnership | <input type="checkbox"/> Other Organization (Describe) |

(d) Name, title and address of the owner, partners or officers of the undersigned are:

| Name | Title | Address |
|------|-------|---------|
| | | |
| | | |
| | | |
| | | |

(e) The names and addresses of all other persons, both natural and corporate, having a substantial interest in the undersigned, and the nature of the interest are (if none, so state):

| Name | Address | Nature of Interest |
|------|---------|--------------------|
| | | |
| | | |
| | | |
| | | |
| | | |
| | | |

(f) The names, addresses and trade classifications of all other building construction contractors in which the undersigned has a substantial interest are (if none, so state):

| Name | Address | Trade Classification |
|------|---------|----------------------|
| | | |
| | | |
| | | |
| | | |
| | | |
| | | |

(Name of Subcontractor)

(Authorized Signature)

Date _____

U.S. Department of Labor
 Employment Standards Administration
 Wage and Hour Division

PAYROLL

(For Contractor's Optional Use; See Instructions, Form WH-347 Inst.)

Persons are not required to respond to the collection of information unless it displays a currently valid OMB control number.



NAME OF CONTRACTOR OR SUBCONTRACTOR ADDRESS OMB No.: 1215-0149
Expires: 03/31/2003

PAYROLL NO. FOR WEEK ENDING PROJECT AND LOCATION PROJECT OR CONTRACT NO.

| (1) NAME, ADDRESS, AND SOCIAL SECURITY NUMBER OF EMPLOYEE | (2) NO. OF WITHHOLDING EXEMPTIONS | (3) WORK CLASSIFICATION | (4) DAY AND DATE | | | | | | | (5) TOTAL HOURS | (6) RATE OF PAY | (7) GROSS AMOUNT EARNED | (8) DEDUCTIONS | | | | | (9) NET WAGES PAID FOR WEEK |
|--|--|-------------------------------|------------------|-----------------------|---|---|---|---|---|-----------------------|-----------------------|----------------------------------|-------------------|-------------------------|-------|---------------------|--------|---|
| | | | OT. OR ST. | HOURS WORKED EACH DAY | | | | | | | | | FICA | WITH- HOLDING TAX | OTHER | TOTAL DEDUCTIONS | | |
| | | | | S | M | T | W | T | F | | | | | | | | S | |
| | | | o | | | | | | | 0.00 | | \$0.00 | | | | | \$0.00 | \$0.00 |
| | | | s | | | | | | | 0.00 | / | | | | | | | |
| | | | o | | | | | | | 0.00 | | \$0.00 | | | | | \$0.00 | \$0.00 |
| | | | s | | | | | | | 0.00 | / | | | | | | | |
| | | | o | | | | | | | 0.00 | | \$0.00 | | | | | \$0.00 | \$0.00 |
| | | | s | | | | | | | 0.00 | / | | | | | | | |
| | | | o | | | | | | | 0.00 | | \$0.00 | | | | | \$0.00 | \$0.00 |
| | | | s | | | | | | | 0.00 | / | | | | | | | |
| | | | o | | | | | | | 0.00 | | \$0.00 | | | | | \$0.00 | \$0.00 |
| | | | s | | | | | | | 0.00 | / | | | | | | | |
| | | | o | | | | | | | 0.00 | | \$0.00 | | | | | \$0.00 | \$0.00 |
| | | | s | | | | | | | 0.00 | / | | | | | | | |
| | | | o | | | | | | | 0.00 | | \$0.00 | | | | | \$0.00 | \$0.00 |
| | | | s | | | | | | | 0.00 | / | | | | | | | |

We estimate that it will take an average of 56 minutes to complete this collection of information, including time for reviewing instructions searching existing data sources, gathering and maintaining the data needed, and completing and reviewing the collection of information. If you have any comments regarding these estimates or any other aspect of this collection of information, including suggestions for reducing this burden, send them to the Administrator, Wage and Hour Division, ESA, U. S. Department of Labor, Room S3502, 200 Constitution Avenue, N. W., Washington, D. C. 20210.

EXHIBIT VIII-T

STATEMENT OF COMPLIANCE, Form WH-348

U.S. DEPARTMENT OF LABOR
WAGE AND HOUR DIVISION

Form Approved
Budget Bureau No. 44-R1093

Date _____

I, _____, _____ do hereby state:
(Name of Signatory Party) (Title)

(1) That I paid or supervised the payment of the person employed by _____
_____ on the _____;
(Contractor or Subcontractor) (Building or Work)

during the payroll period commencing on the _____ day of _____
20__ and ending on the _____ day of _____ 20__ all persons employed on said project have
been paid the full weekly wages earned, that no rebates have been or will be made either directly or
indirectly to or on behalf of said _____
(Contractor or Subcontractor)

person and that no deductions have been made either directly or indirectly from the full wages earned by
any person, other than permissible deductions as defined in Regulations, Part 3 (29 CFR Subtitle A),
issued by the Secretary of Labor under the Copeland Act, as amended (48 Stat. 948.63 Stat. 180, 72
Stat. 967; 76 Stat. 357; 40 U.S.C. 276c), and described below:

(2) That any payrolls otherwise under this contract required to be submitted for the above period are
correct and complete; that the wage rates for laborers or mechanics contained therein are not less than
the applicable wage rates contained in any wage determination incorporated into the contract; that the
classifications set forth therein for each laborer or mechanic conform with the work he performed.

(3) That any apprentices employed in the above period are duly registered in a bona fide apprenticeship
program registered with a State apprenticeship agency recognized by the Bureau of Apprenticeship and
Training, United States Department of Labor, or if no such recognized agency exists in a State, are
registered with the Bureau of Apprenticeship and Training, United States Department of Labor.

EXHIBIT VIII-T, Cont.

(4) That:

(a) WHERE FRINGE BENEFITS ARE PAID TO APPROVED PLANS, FUNDS, OR PROGRAMS

In addition to the basic hourly wage rates paid to each labor or mechanic listed in the above referenced payroll, payments of fringe benefits as listed in the contract have been or will be made to appropriate programs for the benefit of such employees, except as noted in Section 4(c) below.

(b) WHERE FRINGE BENEFITS ARE PAID IN CASH

Each laborer or mechanic listed in the above referenced payroll has been paid as indicated on the payroll, an amount not less than the sum of the applicable basic hourly wage rate plus the amount of the required fringe benefits as listed in the contract, except as noted in Section 4(c) below.

(c) EXCEPTIONS

| EXCEPTIONS (CRAFT) | EXPLANATION |
|--------------------|-------------|
| | |
| | |
| | |
| | |
| | |
| | |
| | |
| | |
| | |

REMARKS:

NAME AND TITLE (Typed) SIGNATURE

THE LAWFUL FALSIFICATION OF ANY OF THE ABOVE STATEMENTS MAY SUBJECT THE CONTRACTOR OR SUBCONTRACTOR TO CIVIL OR CRIMINAL PROSECUTION (SEE SECTION 1001 OF TITLE 16 AND SECTION 231 OF TITLE 31 OF THE UNITED STATES CODE.)

EXHIBIT VIII-T, Cont.

INSTRUCTIONS FOR PREPARATION OF STATEMENT OF COMPLIANCE

This statement of compliance meets needs resulting from the amendment of the Davis-Bacon Act to include fringe benefits provisions. Under this amended law, the contractor is required to pay fringe benefits as predetermined by the Department of Labor, in addition to payment of the minimum rates. The contractor's obligation to pay fringe benefits may be met by payment of the fringes to the various plans, funds, or programs by making these payments to the employees as cash in lieu of fringes.

The contractor should show on the face of his payroll all monies paid to the employees whether as basic rates or as cash in lieu of fringes. The contractor shall represent in the statement of compliance that he is paying to others fringes required by the contract and not paid as cash in lieu of fringes. Detailed instructions follow:

Contractors who pay all required fringe benefits:

A contractor who pays fringe benefits to approved plans, funds, or programs in amounts not less than predetermined in the applicable wage decision of the Secretary of Labor shall continue to show on the face of this payroll the basic cash hourly rate and overtime rate paid to his employees, just as he has always done. Such a contractor shall check paragraph 4(a) of the statement to indicate that he is also paying to approved plans, funds, or programs not less than the amount predetermined as fringe benefits for each craft. Any exception shall be noted in Section 4(c).

Contractors who pay no fringe benefits:

A contractor who pays no fringe benefits shall pay to the employee and insert in the straight time hourly rate column of his payroll an amount not less than the predetermined rate for each classification plus the amount of fringe benefits determined for each classification in the applicable wage decision. Inasmuch as it is not necessary to pay time and a half on cash paid in lieu of fringes, the overtime rate shall be not less than the sum of the basic predetermined rate, plus the half time premium of the basic or regular rate plus the required cash in lieu of fringes at the straight time rate. To simplify computation of overtime, it is suggested that the straight time basic rate and cash in lieu of fringes be separately stated in the hourly rate column, thus \$3.25/.40. In addition, the contractor shall check paragraph 4(b) of the statement to indicate that he is paying fringe benefits in cash directly to his employees. Any exception shall be noted in Section 4(c).

Use of Section 4(c), Exceptions

Any contractor who is making payment to approved plans, funds, or programs in amounts less than the wage determination requires is obligated to pay the deficiency directly to the employees as cash in lieu of fringes. Any exception to Section 4(a) or 4(b), whichever the contractor may check, shall be entered in Section 4(c). Enter in the Exception column the craft and enter in the Explanation column the hourly amount paid the employees as cash in lieu of fringes, and the hourly amount paid to plans, funds, or programs as fringes.

GPO: 1981 0 -345-632

For sale by the Superintendent of Documents
U. S. Government Printing Office
Washington DC 20402

PAYROLL REPORTING

Federal payroll reporting requirements apply to this project. Payroll form WH-347 must be prepared and transmitted to the municipality contracting the project each week until completion.

ALL PAYROLLS MUST CONTAIN THE FOLLOWING:

1. employer's IRS number on the upper left hand corner of the first project payroll
2. name and address of the contractor or subcontractor
3. Number payrolls consecutively (i.e., 1, 2, 3, etc.). **Label the first project payroll "INITIAL" and the last payroll "FINAL."** Submit a "no work" payroll form if work is suspended for a period of time, stating on the form, "NO WORK, weeks ending 10/7/99 to 10/28/99, payrolls 7, 8, 9, 10." Include an authorized certifying signature.
4. project name, location and number
5. (column 1) Each employee's address and social security number must appear on the first payroll on which his name appears.
6. (column 3) Work Classification, consult the wage decision to determine the exact trade title and class, for example, "Laborer group 1" or "Power Equipment Operator group 1".

If an employee is an apprentice, a copy of his registration in a bona-fide apprenticeship program must be submitted with the first payroll on which he is listed.
7. (columns 4) Days and dates, show the hours worked each day on this project, straight time and overtime. Overtime hours are those hours over 40 in a week.
8. (column 5) Total hours for the week for this project, show any overtime hours on line "O" and straight time hours on line "S".
9. (column 6) Hourly rate of pay, it can be more than the base rate shown in the wage decision for the given work classification, but never less. Pay time-and-one-half (Overtime) for hours over 40 in a week (the 40 hours compiled from all work). Calculate the time-and-one-half rate by multiplying the base rate of pay by 1.5 . Fringe benefit payment is required on all hours worked on this job (one rate for fringes no matter what). If a company owner works on the project, enter "NA" (not applicable), followed by "OWNER/OPERATOR.≡ The owner's name, etc., must also appear on the Contractor's or Sub.'s Certification form HUD 1421 or HUD 1422.
10. (column 7) Gross amount earned, show the gross amount earned on this job over the gross amount earned for the week (all work), example: 535.92/759.92 .
11. (columns 8) deductions for the week, all work
12. (column 9) Net wages paid for the week (all work), column 7 figure (all work) minus column 8 figure (total deductions) must equal column 9 figure.

Reverse Side of Payroll

13. "Statement of Compliance," complete the entire reverse side of the payroll form.

Mark the appropriate box indicating the method of fringe benefit payment:

Mark box (4) (a) if the fringe benefits (**in at least the amounts shown in the wage decision**) are paid to approved plans, funds or programs. If such is the case, record only the base rate of pay on the face of the payroll in column 6, on line "S";

Mark box (4) (b) if the fringe benefits are paid to the employees directly in cash, that is, paid to them in their paychecks instead of a plan. If such is the case, record the total fringe benefits paid per hour on the payroll face, under the base rate of pay in column 6, on line "S," example: 15.54/6.79;

If neither of the descriptions given under boxes (4) (a) or (4) (b) conforms exactly to your situation, mark the box (4) (a) **OR** (4) (b) that most closely resembles your company circumstances, but also provide an explanation of the "EXCEPTIONS" (differences) under section (4) (c).

14. Certifying signature, an authorized, original signature must appear in the signature box in the lower right corner, on the back of the payroll form.

Oakland County CDBG Contractor Information Form

Community Name: _____

Please bring the following information to the pre-construction meeting and plan on having your payroll clerk also attend. Certified payrolls will be discussed and need to be correctly submitted on a weekly basis from each contractor that works on the project in order to receive payment for this project.

| Contractor Name | Address | Phone # | IRS # | Contract Amount | General Contractor "Yes or No" | Ethnic Code | Ownership Male or Female |
|-----------------|---------|---------|-------|-----------------|--------------------------------|-------------|--------------------------|
| | | | | | | | |
| | | | | | | | |
| | | | | | | | |
| | | | | | | | |
| | | | | | | | |

Indicate the sex and racial/ethnic character of the owner(s) and controller(s) of 51 percent or more of your business. If 51 percent or more is not owned and controlled by persons (or person) of any single racial/ethnic category, mark the description that seems the most appropriate.

Racial/Ethnic Codes

- 1 = White Americans: persons having origins in any of the original peoples of Europe, North Africa, or the Middle East, but not of Hispanic Origin.
- 2 = Black Americans: persons having origins in any of the black racial groups of Africa, but not of Hispanic origin.
- 3 = Native Americans: Persons having origins in any of the original peoples of North America, and who maintain cultural identifications through tribal affiliations or community recognition.
- 4 = Hispanic Americans: persons of Mexican, Puerto Rican, Cuban, Central or South American or other Spanish culture or origin, regardless of race.
- 5 = Asian/Pacific Americans: persons having origins in any of the original peoples of the Far East, Southeast Asia, the Indian subcontinent, or the Pacific Islands. This area includes, China, India, Japan, Korea, the Philippine Islands, and Samoa.
- 6 = Hasidic Jews

If you have any questions: Mike Pucher, Contract Compliance Officer, 248-858-0196

Record of Employee Interview

U.S. Department of Housing and Urban Development Office of Labor Relations

OMB Approval No. 2501-0009
(exp. 10/31/2010)

Public reporting burden for this collection of information is estimated to average 15 minutes per response, including the time for reviewing instructions, searching existing data sources, gathering and maintaining the data needed, and completing and reviewing the collection of information. This agency may not collect this information, and you are not required to complete this form, unless it displays a currently valid OMB control number. The information is collected to ensure compliance with the Federal labor standards by recording interviews with construction workers. The information collected will assist HUD in the conduct of compliance monitoring; the information will be used to test the veracity of certified payroll reports submitted by the employer. **Sensitive Information.** The information collected on this form is considered sensitive and is protected by the Privacy Act. The Privacy Act requires that these records be maintained with appropriate administrative, technical, and physical safeguards to ensure their security and confidentiality. In addition, these records should be protected against any anticipated threats or hazards to their security or integrity that could result in substantial harm, embarrassment, inconvenience, or unfairness to any individual on whom the information is maintained. The information collected herein is voluntary, and any information provided shall be kept confidential.

| | | | | | |
|--|---|---|---|---|---|
| 1a. Project Name | | | 2a. Employee Name | | |
| 1b. Project Number | | | 2b. Employee Phone Number (including area code) | | |
| 1c. Contractor or Subcontractor (Employer) | | | 2c. Employee Home Address & Zip Code | | |
| | | | 2d. Verification of identification? Yes <input type="checkbox"/> No <input type="checkbox"/> | | |
| 3a. How long on this job? | 3b. Last date on this job before today? | 3c. No. of hours last day on this job? | 4a. Hourly rate of pay? | 4b. Fringe Benefits? | |
| | | | | Vacation Yes <input type="checkbox"/> No <input type="checkbox"/> Medical Yes <input type="checkbox"/> No <input type="checkbox"/> Pension Yes <input type="checkbox"/> No <input type="checkbox"/> | |
| 4c. Pay stub? Yes <input type="checkbox"/> No <input type="checkbox"/> | | | | | |
| 5. Your job classification(s) (list all) --- continue on a separate sheet if necessary | | | | | |
| 6. Your duties | | | | | |
| 7. Tools or equipment used | | | | | |
| 8. Are you an apprentice or trainee? | | Y <input type="checkbox"/> N <input type="checkbox"/> | 10. Are you paid at least time and 1/2 for all hours worked in excess of 40 in a week? | | Y <input type="checkbox"/> N <input type="checkbox"/> |
| 9. Are you paid for all hours worked? | | Y <input type="checkbox"/> N <input type="checkbox"/> | 11. Have you ever been threatened or coerced into giving up any part of your pay? | | Y <input type="checkbox"/> N <input type="checkbox"/> |
| 12a. Employee Signature | | | 12b. Date | | |
| 13. Duties observed by the Interviewer (Please be specific.) | | | | | |
| 14. Remarks | | | | | |
| 15a. Interviewer name (please print) | | | 15b. Signature of Interviewer | | 15c. Date of interview |

Payroll Examination

| | |
|------------------------------------|-----------|
| 16. Remarks | |
| 17a. Signature of Payroll Examiner | 17b. Date |

Applicability

The Project or Program to which the construction work covered by this contract pertains is being assisted by the United States of America and the following Federal Labor Standards Provisions are included in this Contract pursuant to the provisions applicable to such Federal assistance.

A. 1. (i) Minimum Wages. All laborers and mechanics employed or working upon the site of the work, will be paid unconditionally and not less often than once a week, and without subsequent deduction or rebate on any account (except such payroll deductions as are permitted by regulations issued by the Secretary of Labor under the Copeland Act (29 CFR Part 3), the full amount of wages and bona fide fringe benefits (or cash equivalents thereof) due at time of payment computed at rates not less than those contained in the wage determination of the Secretary of Labor which is attached hereto and made a part hereof, regardless of any contractual relationship which may be alleged to exist between the contractor and such laborers and mechanics. Contributions made or costs reasonably anticipated for bona fide fringe benefits under Section 1(b)(2) of the Davis-Bacon Act on behalf of laborers or mechanics are considered wages paid to such laborers or mechanics, subject to the provisions of 29 CFR 5.5(a)(1)(iv); also, regular contributions made or costs incurred for more than a weekly period (but not less often than quarterly) under plans, funds, or programs, which cover the particular weekly period, are deemed to be constructively made or incurred during such weekly period.

Such laborers and mechanics shall be paid the appropriate wage rate and fringe benefits on the wage determination for the classification of work actually performed, without regard to skill, except as provided in 29 CFR 5.5(a)(4). Laborers or mechanics performing work in more than one classification may be compensated at the rate specified for each classification for the time actually worked therein: Provided, That the employer's payroll records accurately set forth the time spent in each classification in which work is performed. The wage determination (including any additional classification and wage rates conformed under 29 CFR 5.5(a)(1)(ii) and the Davis-Bacon poster (WH-1321) shall be posted at all times by the contractor and its subcontractors at the site of the work in a prominent and accessible, place where it can be easily seen by the workers.

(ii) (a) Any class of laborers or mechanics which is not listed in the wage determination and which is to be employed under the contract shall be classified in conformance with the wage determination. HUD shall approve an additional classification and wage rate and fringe benefits therefor only when the following criteria have been met:

(1) The work to be performed by the classification requested is not performed by a classification in the wage determination; and

(2) The classification is utilized in the area by the construction industry; and

(3) The proposed wage rate, including any bona fide fringe benefits, bears a reasonable relationship to the wage rates contained in the wage determination.

(b) If the contractor and the laborers and mechanics to be employed in the classification (if known), or their representatives, and HUD or its designee agree on the classification and wage rate (including the amount designated for fringe benefits where appropriate), a report of the action taken shall be sent by HUD or its designee to the Administrator of the Wage and Hour Division, Employment Standards Administration, U.S. Department of Labor, Washington, D.C. 20210. The Administrator, or an authorized representative, will approve, modify, or disapprove every additional classification action within 30 days of receipt and so advise HUD or its designee or will notify HUD or its designee within the 30-day period that additional time is necessary. (Approved by the Office of Management and Budget under OMB control number 1215-0140.)

(c) In the event the contractor, the laborers or mechanics to be employed in the classification or their representatives, and HUD or its designee do not agree on the proposed classification and wage rate (including the amount designated for fringe benefits, where appropriate), HUD or its designee shall refer the questions, including the views of all interested parties and the recommendation of HUD or its designee, to the Administrator for determination. The Administrator, or an authorized representative, will issue a determination within 30 days of receipt and so advise HUD or its designee or will notify HUD or its designee within the 30-day period that additional time is necessary. (Approved by the Office of Management and Budget under OMB Control Number 1215-0140.)

(d) The wage rate (including fringe benefits where appropriate) determined pursuant to subparagraphs (1)(ii)(b) or (c) of this paragraph, shall be paid to all workers performing work in the classification under this contract from the first day on which work is performed in the classification.

(iii) Whenever the minimum wage rate prescribed in the contract for a class of laborers or mechanics includes a fringe benefit which is not expressed as an hourly rate, the contractor shall either pay the benefit as stated in the wage determination or shall pay another bona fide fringe benefit or an hourly cash equivalent thereof.

(iv) If the contractor does not make payments to a trustee or other third person, the contractor may consider as part

of the wages of any laborer or mechanic the amount of any costs reasonably anticipated in providing bona fide fringe benefits under a plan or program. Provided, That the Secretary of Labor has found, upon the written request of the contractor, that the applicable standards of the Davis-Bacon Act have been met. The Secretary of Labor may require the contractor to set aside in a separate account assets for the meeting of obligations under the plan or program. (Approved by the Office of Management and Budget under OMB Control Number 1215-0140.)

2. Withholding. HUD or its designee shall upon its own action or upon written request of an authorized representative of the Department of Labor withhold or cause to be withheld from the contractor under this contract or any other Federal contract with the same prime contractor, or any other Federally-assisted contract subject to Davis-Bacon prevailing wage requirements, which is held by the same prime contractor so much of the accrued payments or advances as may be considered necessary to pay laborers and mechanics, including apprentices, trainees and helpers, employed by the contractor or any subcontractor the full amount of wages required by the contract. In the event of failure to pay any laborer or mechanic, including any apprentice, trainee or helper, employed or working on the site of the work, all or part of the wages required by the contract, HUD or its designee may, after written notice to the contractor, sponsor, applicant, or owner, take such action as may be necessary to cause the suspension of any further payment, advance, or guarantee of funds until such violations have ceased. HUD or its designee may, after written notice to the contractor, disburse such amounts withheld for and on account of the contractor or subcontractor to the respective employees to whom they are due. The Comptroller General shall make such disbursements in the case of direct Davis-Bacon Act contracts.

3. (i) Payrolls and basic records. Payrolls and basic records relating thereto shall be maintained by the contractor during the course of the work preserved for a period of three years thereafter for all laborers and mechanics working at the site of the work. Such records shall contain the name, address, and social security number of each such worker, his or her correct classification, hourly rates of wages paid (including rates of contributions or costs anticipated for bona fide fringe benefits or cash equivalents thereof of the types described in Section 1(b)(2)(B) of the Davis-bacon Act), daily and weekly number of hours worked, deductions made and actual wages paid. Whenever the Secretary of Labor has found under 29 CFR 5.5 (a)(1)(iv) that the wages of any laborer or mechanic include the amount of any costs reasonably anticipated in providing benefits under a plan or program described in Section 1(b)(2)(B) of the Davis-Bacon Act, the contractor shall maintain records which show that the commitment to provide such benefits is enforceable, that the plan or program is financially responsible, and that the plan or program has been

communicated in writing to the laborers or mechanics affected, and records which show the costs anticipated or the actual cost incurred in providing such benefits. Contractors employing apprentices or trainees under approved programs shall maintain written evidence of the registration of apprenticeship programs and certification of trainee programs, the registration of the apprentices and trainees, and the ratios and wage rates prescribed in the applicable programs. (Approved by the Office of Management and Budget under OMB Control Numbers 1215-0140 and 1215-0017.)

(ii) (a) The contractor shall submit weekly for each week in which any contract work is performed a copy of all payrolls to HUD or its designee if the agency is a party to the contract, but if the agency is not such a party, the contractor will submit the payrolls to the applicant sponsor, or owner, as the case may be, for transmission to HUD or its designee. The payrolls submitted shall set out accurately and completely all of the information required to be maintained under 29 CFR 5.5(a)(3)(i) except that full social security numbers and home addresses shall not be included on weekly transmittals. Instead the payrolls shall only need to include an individually identifying number for each employee (e.g., the last four digits of the employee's social security number). The required weekly payroll information may be submitted in any form desired. Optional Form WH-347 is available for this purpose from the Wage and Hour Division Web site at <https://www.dol.gov/whd/forms/> or its successor site. The prime contractor is responsible for the submission of copies of payrolls by all subcontractors. Contractors and subcontractors shall maintain the full social security number and current address of each covered worker, and shall provide them upon request to HUD or its designee if the agency is a party to the contract, but if the agency is not such a party, the contractor will submit the payrolls to the applicant sponsor, or owner, as the case may be, for transmission to HUD or its designee, the contractor, or the Wage and Hour Division of the Department of Labor for purposes of an investigation or audit of compliance with prevailing wage requirements. It is not a violation of this subparagraph for a prime contractor to require a subcontractor to provide addresses and social security numbers to the prime contractor for its own records, without weekly submission to HUD or its designee. (Approved by the Office of Management and Budget under OMB Control Number 1215-0149.)

(b) Each payroll submitted shall be accompanied by a "Statement of Compliance," signed by the contractor or subcontractor or his or her agent who pays or supervises the payment of the persons employed under the contract and shall certify the following:

(1) That the payroll for the payroll period contains the information required to be provided under 29 CFR 5.5 (a)(3)(ii), the appropriate information is being maintained under 29 CFR 5.5(a)(3)(i), and that such information is correct and complete;

(2) That each laborer or mechanic (including each helper, apprentice, and trainee) employed on the contract during the payroll period has been paid the full weekly wages earned, without rebate, either directly or indirectly, and that no deductions have been made either directly or indirectly from the full wages earned, other than permissible deductions as set forth in 29 CFR Part 3;

(3) That each laborer or mechanic has been paid not less than the applicable wage rates and fringe benefits or cash equivalents for the classification of work performed, as specified in the applicable wage determination incorporated into the contract.

(c) The weekly submission of a properly executed certification set forth on the reverse side of Optional Form WH-347 shall satisfy the requirement for submission of the "Statement of Compliance" required by subparagraph A.3.(ii)(b).

(d) The falsification of any of the above certifications may subject the contractor or subcontractor to civil or criminal prosecution under Section 1001 of Title 18 and Section 231 of Title 31 of the United States Code.

(iii) The contractor or subcontractor shall make the records required under subparagraph A.3.(i) available for inspection, copying, or transcription by authorized representatives of HUD or its designee or the Department of Labor, and shall permit such representatives to interview employees during working hours on the job. If the contractor or subcontractor fails to submit the required records or to make them available, HUD or its designee may, after written notice to the contractor, sponsor, applicant or owner, take such action as may be necessary to cause the suspension of any further payment, advance, or guarantee of funds. Furthermore, failure to submit the required records upon request or to make such records available may be grounds for debarment action pursuant to 29 CFR 5.12.

4. Apprentices and Trainees.

(i) **Apprentices.** Apprentices will be permitted to work at less than the predetermined rate for the work they performed when they are employed pursuant to and individually registered in a bona fide apprenticeship program registered with the U.S. Department of Labor, Employment and Training Administration, Office of Apprenticeship Training, Employer and Labor Services, or with a State Apprenticeship Agency recognized by the Office, or if a person is employed in his or her first 90 days of probationary employment as an apprentice in such an apprenticeship program, who is not individually registered in the program, but who has been certified by the Office of Apprenticeship Training, Employer and Labor Services or a State Apprenticeship Agency (where appropriate) to be eligible for probationary employment as an apprentice. The allowable ratio of apprentices to journeymen on the job site in any craft classification shall not be greater than the ratio permitted to the contractor as to the entire work force under the registered program. Any worker listed on a payroll at an apprentice wage rate, who

is not registered or otherwise employed as stated above, shall be paid not less than the applicable wage rate on the wage determination for the classification of work actually performed. In addition, any apprentice performing work on the job site in excess of the ratio permitted under the registered program shall be paid not less than the applicable wage rate on the wage determination for the work actually performed. Where a contractor is performing construction on a project in a locality other than that in which its program is registered, the ratios and wage rates (expressed in percentages of the journeyman's hourly rate) specified in the contractor's or subcontractor's registered program shall be observed. Every apprentice must be paid at not less than the rate specified in the registered program for the apprentice's level of progress, expressed as a percentage of the journeymen hourly rate specified in the applicable wage determination. Apprentices shall be paid fringe benefits in accordance with the provisions of the apprenticeship program. If the apprenticeship program does not specify fringe benefits, apprentices must be paid the full amount of fringe benefits listed on the wage determination for the applicable classification. If the Administrator determines that a different practice prevails for the applicable apprentice classification, fringes shall be paid in accordance with that determination. In the event the Office of Apprenticeship Training, Employer and Labor Services, or a State Apprenticeship Agency recognized by the Office, withdraws approval of an apprenticeship program, the contractor will no longer be permitted to utilize apprentices at less than the applicable predetermined rate for the work performed until an acceptable program is approved.

(ii) **Trainees.** Except as provided in 29 CFR 5.16, trainees will not be permitted to work at less than the predetermined rate for the work performed unless they are employed pursuant to and individually registered in a program which has received prior approval, evidenced by formal certification by the U.S. Department of Labor, Employment and Training Administration. The ratio of trainees to journeymen on the job site shall not be greater than permitted under the plan approved by the Employment and Training Administration. Every trainee must be paid at not less than the rate specified in the approved program for the trainee's level of progress, expressed as a percentage of the journeyman hourly rate specified in the applicable wage determination. Trainees shall be paid fringe benefits in accordance with the provisions of the trainee program. If the trainee program does not mention fringe benefits, trainees shall be paid the full amount of fringe benefits listed on the wage determination unless the Administrator of the Wage and Hour Division determines that there is an apprenticeship program associated with the corresponding journeyman wage rate on the wage determination which provides for less than full fringe benefits for apprentices. Any employee listed on the payroll at a trainee rate who is not registered and participating in a training plan approved by

the Employment and Training Administration shall be paid not less than the applicable wage rate on the wage determination for the work actually performed. In addition, any trainee performing work on the job site in excess of the ratio permitted under the registered program shall be paid not less than the applicable wage rate on the wage determination for the work actually performed. In the event the Employment and Training Administration withdraws approval of a training program, the contractor will no longer be permitted to utilize trainees at less than the applicable predetermined rate for the work performed until an acceptable program is approved.

(iii) **Equal employment opportunity.** The utilization of apprentices, trainees and journeymen under 29 CFR Part 5 shall be in conformity with the equal employment opportunity requirements of Executive Order 11246, as amended, and 29 CFR Part 30.

5. Compliance with Copeland Act requirements. The contractor shall comply with the requirements of 29 CFR Part 3 which are incorporated by reference in this contract

6. Subcontracts. The contractor or subcontractor will insert in any subcontracts the clauses contained in subparagraphs 1 through 11 in this paragraph A and such other clauses as HUD or its designee may by appropriate instructions require, and a copy of the applicable prevailing wage decision, and also a clause requiring the subcontractors to include these clauses in any lower tier subcontracts. The prime contractor shall be responsible for the compliance by any subcontractor or lower tier subcontractor with all the contract clauses in this paragraph.

7. Contract termination; debarment. A breach of the contract clauses in 29 CFR 5.5 may be grounds for termination of the contract and for debarment as a contractor and a subcontractor as provided in 29 CFR 5.12.

8. Compliance with Davis-Bacon and Related Act Requirements. All rulings and interpretations of the Davis-Bacon and Related Acts contained in 29 CFR Parts 1, 3, and 5 are herein incorporated by reference in this contract

9. Disputes concerning labor standards. Disputes arising out of the labor standards provisions of this contract shall not be subject to the general disputes clause of this contract. Such disputes shall be resolved in accordance with the procedures of the Department of Labor set forth in 29 CFR Parts 5, 6, and 7. Disputes within the meaning of this clause include disputes between the contractor (or any of its subcontractors) and HUD or its designee, the U.S. Department of Labor, or the employees or their representatives.

10. (i) Certification of Eligibility. By entering into this contract the contractor certifies that neither it (nor he or she) nor any person or firm who has an interest in the contractor's firm is a person or firm ineligible to be awarded Government contracts by virtue of Section 3(a) of the Davis-Bacon Act or 29 CFR 5.12(a)(1) or to be

awarded HUD contracts or participate in HUD programs pursuant to 24 CFR Part 24.

(ii) No part of this contract shall be subcontracted to any person or firm ineligible for award of a Government contract by virtue of Section 3(a) of the Davis-Bacon Act or 29 CFR 5.12(a)(1) or to be awarded HUD contracts or participate in HUD programs pursuant to 24 CFR Part 24.

(iii) The penalty for making false statements is prescribed in the U.S. Criminal Code, 18 U.S.C. 1001. Additionally, U.S. Criminal Code, Section 1 01 0, Title 18, U.S.C., "Federal Housing Administration transactions", provides in part: "Whoever, for the purpose of . . . influencing in any way the action of such Administration..... makes, utters or publishes any statement knowing the same to be false..... shall be fined not more than \$5,000 or imprisoned not more than two years, or both."

11. Complaints, Proceedings, or Testimony by Employees. No laborer or mechanic to whom the wage, salary, or other labor standards provisions of this Contract are applicable shall be discharged or in any other manner discriminated against by the Contractor or any subcontractor because such employee has filed any complaint or instituted or caused to be instituted any proceeding or has testified or is about to testify in any proceeding under or relating to the labor standards applicable under this Contract to his employer.

B. Contract Work Hours and Safety Standards Act. The provisions of this paragraph B are applicable where the amount of the prime contract exceeds \$100,000. As used in this paragraph, the terms "laborers" and "mechanics" include watchmen and guards.

(1) Overtime requirements. No contractor or subcontractor contracting for any part of the contract work which may require or involve the employment of laborers or mechanics shall require or permit any such laborer or mechanic in any workweek in which the individual is employed on such work to work in excess of 40 hours in such workweek unless such laborer or mechanic receives compensation at a rate not less than one and one-half times the basic rate of pay for all hours worked in excess of 40 hours in such workweek.

(2) Violation; liability for unpaid wages; liquidated damages. In the event of any violation of the clause set forth in subparagraph (1) of this paragraph, the contractor and any subcontractor responsible therefor shall be liable for the unpaid wages. In addition, such contractor and subcontractor shall be liable to the United States (in the case of work done under contract for the District of Columbia or a territory, to such District or to such territory), for liquidated damages. Such liquidated damages shall be computed with respect to each individual laborer or mechanic, including watchmen and guards, employed in violation of the clause set forth in subparagraph (1) of this paragraph, in the sum of \$10 for each calendar day on which such individual was required or permitted to work in excess of the standard workweek of 40 hours without payment of the overtime wages required by the clause set forth in subparagraph (1) of this paragraph.

(3) Withholding for unpaid wages and liquidated damages. HUD or its designee shall upon its own action or upon written request of an authorized representative of the Department of Labor withhold or cause to be withheld, from any moneys payable on account of work performed by the contractor or subcontractor under any such contract or any other Federal contract with the same prime contract, or any other Federally-assisted contract subject to the Contract Work Hours and Safety Standards Act which is held by the same prime contractor such sums as may be determined to be necessary to satisfy any liabilities of such contractor or subcontractor for unpaid wages and liquidated damages as provided in the clause set forth in subparagraph (2) of this paragraph.

(4) Subcontracts. The contractor or subcontractor shall insert in any subcontracts the clauses set forth in subparagraph (1) through (4) of this paragraph and also a clause requiring the subcontractors to include these clauses in any lower tier subcontracts. The prime contractor shall be responsible for compliance by any subcontractor or lower tier subcontractor with the clauses set forth in subparagraphs (1) through (4) of this paragraph.

C. Health and Safety. The provisions of this paragraph C are applicable where the amount of the prime contract exceeds \$100,000.

(1) No laborer or mechanic shall be required to work in surroundings or under working conditions which are unsanitary, hazardous, or dangerous to his health and safety as determined under construction safety and health standards promulgated by the Secretary of Labor by regulation.

(2) The Contractor shall comply with all regulations issued by the Secretary of Labor pursuant to Title 29 Part 1926 and failure to comply may result in imposition of sanctions pursuant to the Contract Work Hours and Safety Standards Act, (Public Law 91-54, 83 Stat 96). 40 USC 3701 et seq.

(3) The contractor shall include the provisions of this paragraph in every subcontract so that such provisions will be binding on each subcontractor. The contractor shall take such action with respect to any subcontractor as the Secretary of Housing and Urban Development or the Secretary of Labor shall direct as a means of enforcing such provisions.

STANDARD FEDERAL EQUAL EMPLOYMENT
OPPORTUNITY
CONSTRUCTION CONTRACT SPECIFICATIONS
(EXECUTIVE ORDER 11246)

a) The equal opportunity clause published at 41 CFR 60-1.4(a) of this chapter is required to be included in, and is part of, all nonexempt Federal contracts and subcontracts, including construction contracts and subcontracts. The equal opportunity clause published at 41 CFR 60-1.4(b) is required to be included in, and is a part of, all nonexempt federally assisted construction contracts and subcontracts. In addition to the clauses described above, all Federal contracting officers, all applicants and all nonconstruction contractors, as applicable, shall include the specifications set forth in this section in all Federal and federally assisted construction contracts in excess of \$10,000 to be performed in geographical areas designated by the Director pursuant to Sec. 60-4.6 of this part and in construction subcontracts in excess of \$10,000 necessary in whole or in part to the performance of nonconstruction Federal contracts and subcontracts covered under the Executive order.

Standard Federal Equal Employment Opportunity Construction Contract
Specifications (Executive Order 11246)

1. As used in these specifications:
 - a. "Covered area" means the geographical area described in the solicitation from which this contract resulted;
 - b. "Director" means Director, Office of Federal Contract Compliance Programs, United States Department of Labor, or any person to whom the Director delegates authority;
 - c. "Employer identification number" means the Federal Social Security number used on the Employer's Quarterly Federal Tax Return, U.S. Treasury Department Form 941.
 - d. "Minority" includes:
 - (i) Black (all persons having origins in any of the Black African racial groups not of Hispanic origin);
 - (ii) Hispanic (all persons of Mexican, Puerto Rican, Cuban, Central or South American or other Spanish Culture or origin, regardless of

race);

(iii) Asian and Pacific Islander (all persons having origins in any of the original peoples of the Far East, Southeast Asia, the Indian Subcontinent, or the Pacific Islands); and

(iv) American Indian or Alaskan Native (all persons having origins in any of the original peoples of North America and maintaining identifiable tribal affiliations through membership and participation or community identification).

2. Whenever the Contractor, or any Subcontractor at any tier, subcontracts a portion of the work involving any construction trade, it shall physically include in each subcontract in excess of \$10,000 the provisions of these specifications and the Notice which contains the applicable goals for minority and female participation and which is set forth in the solicitations from which this contract resulted.

3. If the Contractor is participating (pursuant to 41 CFR 60-4.5) in a Hometown Plan approved by the U.S. Department of Labor in the covered area either individually or through an association, its affirmative action obligations on all work in the Plan area (including goals and timetables) shall be in accordance with that Plan for those trades which have unions participating in the Plan. Contractors must be able to demonstrate their participation in and compliance with the provisions of any such Hometown Plan. Each Contractor or Subcontractor participating in an approved Plan is individually required to comply with its obligations under the EEO clause, and to make a good faith effort to achieve each goal under the Plan in each trade in which it has employees. The overall good faith performance by other Contractors or Subcontractors toward a goal in an approved Plan does not excuse any covered Contractor's or Subcontractor's failure to take good faith efforts to achieve the Plan goals and timetables.

4. The Contractor shall implement the specific affirmative action standards provided in paragraphs 7 a through p of these specifications. The goals set forth in the solicitation from which this contract resulted are expressed as percentages of the total hours of employment and training of minority and female utilization the Contractor should reasonably be able to achieve in each construction trade in which it has employees in the covered area. Covered Construction contractors performing construction work in geographical areas where they do not have a Federal or federally assisted construction contract shall apply the minority and female goals established for the geographical area where the work is being performed. Goals are published periodically in

the Federal Register in notice form, and such notices may be obtained from any Office of Federal Contract Compliance Programs office or from Federal procurement contracting officers. The Contractor is expected to make substantially uniform progress in meeting its goals in each craft during the period specified.

5. Neither the provisions of any collective bargaining agreement, nor the failure by a union with whom the Contractor has a collective bargaining agreement, to refer either minorities or women shall excuse the Contractor's obligations under these specifications, Executive Order 11246, or the regulations promulgated pursuant thereto.

6. In order for the nonworking training hours of apprentices and trainees to be counted in meeting the goals, such apprentices and trainees must be employed by the Contractor during the training period, and the Contractor must have made a commitment to employ the apprentices and trainees at the completion of their training, subject to the availability of employment opportunities. Trainees must be trained pursuant to training programs approved by the U.S. Department of Labor.

7. The Contractor shall take specific affirmative actions to ensure equal employment opportunity. The evaluation of the Contractor's compliance with these specifications shall be based upon its effort to achieve maximum results from its actions. The Contractor shall document these efforts fully, and shall implement affirmative action steps at least as extensive as the following:

a. Ensure and maintain a working environment free of harassment, intimidation, and coercion at all sites, and in all facilities at which the Contractor's employees are assigned to work. The Contractor, where possible, will assign two or more women to each construction project. The Contractor shall specifically ensure that all foremen, superintendents, and other on-site supervisory personnel are aware of and carry out the Contractor's obligation to maintain such a working environment, with specific attention to minority or female individuals working at such sites or in such facilities.

b. Establish and maintain a current list of minority and female recruitment sources, provide written notification to minority and female recruitment sources and to community organizations when the Contractor or its unions have employment opportunities available, and maintain a record of the organizations' responses.

c. Maintain a current file of the names, addresses and telephone numbers of each minority and female off-the-street applicant and minority or female referral from a union, a recruitment source or

community organization and of what action was taken with respect to each such individual. If such individual was sent to the union hiring hall for referral and was not referred back to the Contractor by the union or, if referred, not employed by the Contractor, this shall be documented in the file with the reason therefor, along with whatever additional actions the Contractor may have taken.

d. Provide immediate written notification to the Director when the union or unions with which the Contractor has a collective bargaining agreement has not referred to the Contractor a minority person or woman sent by the Contractor, or when the Contractor has other information that the union referral process has impeded the Contractor's efforts to meet its obligations.

e. Develop on-the-job training opportunities and/or participate in training programs for the area which expressly include minorities and women, including upgrading programs and apprenticeship and trainee programs relevant to the Contractor's employment needs, especially those programs funded or approved by the Department of Labor. The Contractor shall provide notice of these programs to the sources compiled under 7b above.

f. Disseminate the Contractor's EEO policy by providing notice of the policy to unions and training programs and requesting their cooperation in assisting the Contractor in meeting its EEO obligations; by including it in any policy manual and collective bargaining agreement; by publicizing it in the company newspaper, annual report, etc.; by specific review of the policy with all management personnel and with all minority and female employees at least once a year; and by posting the company EEO policy on bulletin boards accessible to all employees at each location where construction work is performed.

g. Review, at least annually, the company's EEO policy and affirmative action obligations under these specifications with all employees having any responsibility for hiring, assignment, layoff, termination or other employment decisions including specific review of these items with onsite supervisory personnel such as Superintendents, General Foremen, etc., prior to the initiation of construction work at any job site. A written record shall be made and maintained identifying the time and place of these meetings, persons attending, subject matter discussed, and disposition of the subject matter.

h. Disseminate the Contractor's EEO policy externally by including it in any advertising in the news media, specifically including minority and female news media, and providing written notification to and

discussing the Contractor's EEO policy with other Contractors and Subcontractors with whom the Contractor does or anticipates doing business.

i. Direct its recruitment efforts, both oral and written, to minority, female and community organizations, to schools with minority and female students and to minority and female recruitment and training organizations serving the Contractor's recruitment area and employment needs. Not later than one month prior to the date for the acceptance of applications for apprenticeship or other training by any recruitment source, the Contractor shall send written notification to organizations such as the above, describing the openings, screening procedures, and tests to be used in the selection process.

j. Encourage present minority and female employees to recruit other minority persons and women and, where reasonable, provide after school, summer and vacation employment to minority and female youth both on the site and in other areas of a Contractor's work force.

k. Validate all tests and other selection requirements where there is an obligation to do so under 41 CFR Part 60-3.

l. Conduct, at least annually, an inventory and evaluation at least of all minority and female personnel for promotional opportunities and encourage these employees to seek or to prepare for, through appropriate training, etc., such opportunities.

m. Ensure that seniority practices, job classifications, work assignments and other personnel practices, do not have a discriminatory effect by continually monitoring all personnel and employment related activities to ensure that the EEO policy and the Contractor's obligations under these specifications are being carried out.

n. Ensure that all facilities and company activities are nonsegregated except that separate or single-user toilet and necessary changing facilities shall be provided to assure privacy between the sexes.

o. Document and maintain a record of all solicitations of offers for subcontracts from minority and female construction contractors and suppliers, including circulation of solicitations to minority and female contractor associations and other business associations.

p. Conduct a review, at least annually, of all supervisors' adherence to and performance under the Contractor's EEO policies and affirmative action obligations.

8. Contractors are encouraged to participate in voluntary associations which assist in fulfilling one or more of their affirmative

action obligations (7a through p). The efforts of a contractor association, joint contractor-union, contractor-community, or other similar group of which the contractor is a member and participant, may be asserted as fulfilling any one or more of its obligations under 7a through p of these Specifications provided that the contractor actively participates in the group, makes every effort to assure that the group has a positive impact on the employment of minorities and women in the industry, ensures that the concrete benefits of the program are reflected in the Contractor's minority and female workforce participation, makes a good faith effort to meet its individual goals and timetables, and can provide access to documentation which demonstrates the effectiveness of actions taken on behalf of the Contractor. The obligation to comply, however, is the Contractor's and failure of such a group to fulfill an obligation shall not be a defense for the Contractor's noncompliance.

9. A single goal for minorities and a separate single goal for women have been established. The Contractor, however, is required to provide equal employment opportunity and to take affirmative action for all minority groups, both male and female, and all women, both minority and non-minority. Consequently, the Contractor may be in violation of the Executive Order if a particular group is employed in a substantially disparate manner (for example, even though the Contractor has achieved its goals for women generally, the Contractor may be in violation of the Executive Order if a specific minority group of women is underutilized).

10. The Contractor shall not use the goals and timetables or affirmative action standards to discriminate against any person because of race, color, religion, sex, or national origin.

11. The Contractor shall not enter into any Subcontract with any person or firm debarred from Government contracts pursuant to Executive Order 11246.

12. The Contractor shall carry out such sanctions and penalties for violation of these specifications and of the Equal Opportunity Clause, including suspension, termination and cancellation of existing subcontracts as may be imposed or ordered pursuant to Executive Order 11246, as amended, and its implementing regulations, by the Office of Federal Contract Compliance Programs. Any Contractor who fails to carry out such sanctions and penalties shall be in violation of these specifications and Executive Order 11246, as amended.

13. The Contractor, in fulfilling its obligations under these specifications, shall implement specific affirmative action steps, at

least as extensive as those standards prescribed in paragraph 7 of these specifications, so as to achieve maximum results from its efforts to ensure equal employment opportunity. If the Contractor fails to comply with the requirements of the Executive Order, the implementing regulations, or these specifications, the Director shall proceed in accordance with 41 CFR 60-4.8.

14. The Contractor shall designate a responsible official to monitor all employment related activity to ensure that the company EEO policy is being carried out, to submit reports relating to the provisions hereof as may be required by the Government and to keep records. Records shall at least include for each employee the name, address, telephone numbers, construction trade, union affiliation if any, employee identification number when assigned, social security number, race, sex, status (e.g., mechanic, apprentice trainee, helper, or laborer), dates of changes in status, hours worked per week in the indicated trade, rate of pay, and locations at which the work was performed. Records shall be maintained in an easily understandable and retrievable form; however, to the degree that existing records satisfy this requirement, contractors shall not be required to maintain separate records.

15. Nothing herein provided shall be construed as a limitation upon the application of other laws which establish different standards of compliance or upon the application of requirements for the hiring of local or other area residents (e.g., those under the Public Works Employment Act of 1977 and the Community Development Block Grant Program).

(b) The notice set forth in 41 CFR 60-4.2 and the specifications set forth in 41 CFR 60-4.3 replace the New Form for Federal Equal Employment

Opportunity Bid Conditions for Federal and Federally Assisted Construction published at 41 FR 32482 and commonly known as the Model Federal EEO Bid Conditions, and the New Form shall not be used after the regulations in 41 CFR Part 60-4 become effective.

[43 FR 49254, Oct. 20, 1978; 43 FR 51401, Nov. 3, 1978, as amended at 45 FR 65978, Oct. 3, 1980]

**Oakland County
Community & Home Improvement
Section 3
Contractor Report**

NEW HIRES (includes workers who have worked with the contractor in the recent past but did not continue to work for the contractor since the last job.)

This form is distributed to the General Contractor at the contract signing. The general contractor is also required to provide this form to any subcontractors they hire for this project.

| | |
|------------------------|-----------------------|
| Contractor Name: | |
| Oakland County File #: | |
| Municipality: | |
| Project Name: | |
| Contract Amount: | \$ |
| Time on Job: | From: _____ To: _____ |

Review the information below and check all that apply for this project:

_____ We **currently** have _____ number of employees who meet Section 3 income criteria.

_____ We **recently** hired _____ number of employees who meet Section 3 income criteria.

_____ We **have** _____ Section 3 employees that live within the Metropolitan/Statistical Area (MSA) (Southeast Michigan).

_____ We **have not** hired any new employees.

We have taken one or more of the following recruitment steps to find MSA Target Area Vicinity residents and residents that meet Section 3 criteria.

_____ We **have advertised** to fill vacancies at the site, where work is taking place, in connection with this project via the following.

- _____ Place signs or posters in prominent places within the target area vicinity
- _____ Taken photographs of the above item to document that the above step was carried out
- _____ Distribute employment flyers in locations accessible to MSA vicinity residents
- _____ Post employment flyers in various locations within the MSA vicinity areas
- _____ Requested training on MSA Vicinity Hiring and Section 3 employment requirement

Print Name: _____ Signature: _____

Date: _____

**CONTRACTING WITH
WOMEN'S AND MINORITY BUSINESS ENTERPRISE (W/MBE)
SMALL AND LABOR SURPLUS AREA FIRMS**

- A. Please use the attached W/MBE solicitation list when procuring contractors for bids.
- B. It is national policy to award a fair share of contracts to small and minority business firms. Accordingly, affirmative steps must be taken to assure that small and minority businesses are utilized when possible as sources of supplies, equipment, construction and services.
- C. Affirmative steps shall include the following:
 - (1) Including qualified small and minority businesses on solicitation lists.
 - (2) Assuring that small and minority businesses are solicited whenever they are potential sources.
 - (3) When economically feasible, dividing total requirements into smaller tasks or quantities so as to permit maximum small and minority business participation.
 - (4) Where the requirement permits, establishing delivery schedules which will encourage participation by small and minority business.
 - (5) Using the services and assistance of a Small Business Administration, the Office of Minority Business Enterprise of the Department of Commerce and Community Services Administration as required.
 - (6) If any subcontracts are to be let requires the prime contractor to take the affirmative steps in 1 through 5 above.
- D. Grantees shall take similar appropriate affirmative action in support of women's business enterprises.
- E. Grantees are encouraged to procure goods and services from labor surplus areas.
- F. Grantor agencies may impose additional regulations and requirements in the foregoing areas only to the extent specifically mandated by statute or presidential direction.

ETHNIC OWNERSHIP REPORT

Attention general contractor and subcontractors, please respond to the following (print or type). Mark the descriptions below that indicate the sex and racial/ethnic character of the owner(s) and controller(s) of 51 percent or more of your business. If 51 percent or more is not owned and controlled by persons (or person) of any single racial/ethnic category, mark the description that seems the most appropriate.

Female

Male

White Americans: persons having origins in any of the original peoples of Europe, North Africa, or the Middle East, but not of Hispanic Origin.

Black Americans: persons having origins in any of the black racial groups of Africa, but not of Hispanic origin.

Native Americans: persons having origins in any of the original peoples of North America, and who maintain cultural identifications through tribal affiliations or community recognition.

Hispanic Americans: persons of Mexican, Puerto Rican, Cuban, Central or South American or other Spanish culture or origin, regardless of race.

Asian/Pacific Americans: persons having origins in any of the original peoples of the Far East, Southeast Asia, the Indian subcontinent, or the Pacific Islands. This area includes, for example, China, India, Japan, Korea, the Philippine Islands, and Samoa.

Other: Please Specify: _____

Date _____

Project _____

Business Name _____

Representative Name _____

Position _____

Signature _____

Any questions? Call Mike Pucher, Supervisor, Contract Compliance Unit (248) 858-0196



*CDBG
Contract Provisions*

A grantee's and subgrantee's contracts must contain the provisions listed here. Federal agencies are permitted to require changes, remedies, changed conditions, access and records retention, suspension of work, and other clauses approved by the Office of Federal Procurement Policy.

- (1) Administrative, contractual, or legal remedies in instances where contractors violate or breach contract terms, and provide for such sanctions and penalties as may be appropriate. (Contractors more than the simplified acquisition threshold)
- (2) Termination for cause and for convenience by the grantee or subgrantee including the manner by which it will be effected and the basis for settlement. (All contracts in excess of \$10,000)
- (3) Compliance with Executive Order 11246 of September 24, 1965, entitled "Equal Employment Opportunity, " as amended by Executive Order 11375 October 13, 1967, and as supplemented in Department of Labor regulations (41 CFR chapter 60). (All construction contracts awarded in excess of \$10,000 by grantees and their contractors or subgrantees)
- (4) Compliance. With the Copeland "Anti-Kickback" Act (18 U.S.C. 874) as supplemented in Department of Labor regulations (29 CFR part 3). (All contracts and subgrants for construction or repair)
- (5) Compliance with Davis Bacon Act (40 U.S.C.276a to 276a-7) as supplemented by Department of Labor regulations (29 CFR part 5). (Construction contracts in excess of \$2000 awarded by grantees and subgrantees when required by Federal grant program legislation)
- (6) Compliance with Sections 103 and 107 of the Contract Work Hours and Safety Standards Act (40 U.S.C. 327-330) as supplemented by Department of Labor regulations (29 CFR part 5). (Construction contracts awarded by grantees and subgrantees in excess of \$2000, and in excess of \$2500 for other contracts which involve the employment of mechanics or laborers)
- (7) Notice of awarding agency requirements and regulations pertaining to reporting.
- (8) Notice of awarding agency requirements and regulations pertaining to patent rights with respect to any discovery or invention, which arises or is developed in the course of or under such contract.

- (9) Awarding agency requirements and regulations pertaining to copyrights and rights in data.
- (10) Access by the grantee, the subgrantee, the Federal grantor agency, the Comptroller General of the United States, or any of their duly authorized representatives to any books, documents, papers, and records of the contractor, which are directly pertinent to that specific contract for the purpose of making audit, examination, excerpts, and transcriptions.
- (11) Retention of all required records for three years after grantees or subgrantees make final payments and all other pending matters are closed.
- (12) Compliance with all applicable standards, orders, or requirements issued under section 306 of the Clean Air Act (42 U.S.C. 1857 (h)), section 508 of the Clean Water Act (33 U.S.C. 1368), Executive Order 11788, and Environmental Protection Agency regulations (40 CFR part 15). (Contracts, subcontracts, and subgrants of amounts in excess of \$100,000).
- (13) Mandatory standards and policies relating to energy efficiency which are contained in the state energy conservation plan issued in compliance with the Energy Policy and Conservation Act (Pub. L. 94-163, 89 Stat. 871). [53 FR 8068, 8087, Mar. 11, 1988, as amended at 60 FR 19639, 19642, Apr. 19, 1995]
- (14) Debarment, Suspension, Ineligibility and Voluntary Exclusion
The Service Agency shall comply with the provisions of 24 CFR Part 24 that neither it nor its principals is presently debarred, suspended, proposed for debarment, declared ineligible, or voluntarily excluded from participation in this contract. Additionally, the Contractor shall not use, directly or indirectly, any of the funds provided by this contract to employ, award contracts to, or otherwise engage the services of, or fund any contractor/subcontractor during any period that the contractor/subcontractor is debarred, suspended or ineligible under the provisions of 24 CFR Part 24. Using the Excluded Parties Listing System (<https://www.sam.gov/SAM/>), Oakland County Community & Home Improvement Division has determined, as of the date of this contract that the Contractor is not excluded from Federal Procurement and Non-procurement Programs.

CDBG Davis – Bacon
Initial Start Up Form

Date: _____

Community: _____

Detailed Description of Project: _____

Prevailing Wage decision (Name, Number, Date) _____

NOTE: 10 days prior to bid opening check W.D.for any updates

List CDBG Allocation per year specifically for this project: _____

Account #: _____

Account Name: _____

Estimated Cost: _____

Advertise Date: _____

Bid Opening Date: _____

Contact Person: _____

Title: _____

Address: _____

Phone #: _____

I have downloaded the required CDBG Davis Bacon Information:

X _____

(sign&date)

cc: (Municipal Representative) _____

**Oakland County
Community & Home Improvement
Section 3
Employee Income Certification Form**

| | |
|-----------------------------------|----------------|
| Name: | Date: |
| Address: City & State: Zip: | |
| Telephone Number: | Email Address: |

As an employee of _____, I certify that my total gross household income last year was not greater than (based on the number of persons in the family) the amount checked below.

| Family Size | Section 3 Gross Household Income Limits | CHECK ONE (√) | |
|-------------|---|-----------------------------------|-----------------------------------|
| | | Household Income Less Than (√) | Household Income More Than (√) |
| 1 | \$38,450 | | |
| 2 | \$43,950 | | |
| 3 | \$49,450 | | |
| 4 | \$54,900 | | |
| 5 | \$59,300 | | |
| 6 | \$63,700 | | |
| 7 | \$68,100 | | |
| 8 | \$72,500 | | |

PENALTY FOR FALSE OR FRAUDULENT STATEMENT: U.S.C. title 18, Sec. 1001, provides: "Whoever, in any matter within the jurisdiction of any department or agency of the United States knowingly and willfully falsifies or makes any false, fictitious or fraudulent statements or representations, or makes or uses any false writing, or document knowing the same to contain any false, fictitious or fraudulent statement or entry, shall be fined not more than \$10,000 or imprisoned not more than five (5) years, or both."

Signature: _____ Date: _____

**Oakland County
CDBG
Construction Bonding Requirements**

For construction or facility improvement contracts or subcontracts exceeding \$50,000.00 the following bonds are required.

- 1) A performance bond shall be delivered to the Agency when the contract is executed on the part of the contractor for 100% of the contract price. A "performance bond" is one executed in connection with a contract to secure fulfillment of all the contractor's obligations under such contract.

- 2) *A payment bond (labor & material bond) shall be delivered to the Agency when the contract is executed on the part of the contractor for 100% of the contract price.* A "payment bond" is one executed in connection with a contract to assure payment as required by law of all persons supplying labor and material in the execution of the work provided for in the contract.

Performance and payment bonds must be submitted at the time of contract signing.

**Oakland County
CDBG
Bid Bonding Requirements**

For construction or facility improvement contracts or subcontracts the following bonds are required.

- 1) *A bid guarantee from each bidder equivalent to 5% of the bid price.* The "bid guarantee" shall consist of a firm commitment such as a bid bond, certified check, or other negotiable instrument **accompanying a bid** as assurance that the bidder will, upon acceptance of his bid, execute such contractual documents as may be required within the time specified.

If a contractor fails to deliver the required bonds, the bid will be rejected.

OC File # _____

**Sworn Statement
Oakland County Community and Home Improvement**

_____ being duly sworn, deposes and says that _____ is the
(contractor) (Sub-Contractor) for an improvement to the following described real property situated in: Oakland County, Michigan, described as follows:

That the following is a statement of each subcontractor and supplier and laborer, for which laborer the payment of wages of fringe benefits and withholdings is due but unpaid, with whom the (contractor)(subcontractor) has (contracted) (subcontracted) for performance under the contract with the owner or lessee thereof, and that the amounts due to the persons as of the date hereof are correctly and fully set forth opposite their names, as follows:

| Number | Subcontractor | Type of improvement furnished | Amount currently owed |
|--------|---------------|-------------------------------|-----------------------|
| 1 | | | |
| 2 | | | |
| 3 | | | |
| 4 | | | |
| 5 | | | |
| 6 | | | |
| 7 | | | |
| 8 | | | |
| 9 | | | |
| 10 | | | |

That the contractor has not procured material from, or subcontracted with, any person other than those set forth above and owes no money for the improvement other than the sums set forth above.

Deponent further says that he or she makes the foregoing statement as the (contractor) (subcontractor) or as Owner of the (contractor) (subcontractor) for the purpose of representing to the owner of the above-described premises and his or her agents that the above-described property is free from claims of construction liens, or the possibility of construction liens, except as specifically set forth above and except for claims of construction liens by laborers which may be provided pursuant to Section 109 of the Construction Lien Act, Act No.497 of the Public Acts of 1980, as amended, being Section 570.1109 of the Michigan Compiled Laws.

WARNING TO OWNER: AN OWNER OR LESSEE OF THE ABOVE-DESCRIBED PROERTY MAY NOT RELY ON THIS SWORN STATEMENT TO AVOID THE CLAIM OF A SUBCONTRACTOR, SUPPLIER, OR LABORER WHO HAS PROVIDED A NOTICE OF FURNISHING OR A LABORER WHO MAY PROVIDE A NOTICE OF FURNISHING PURSUANT TO SECTION 109 OF THE MICHIGAN CONSTRUCTION LIEN ACT TO THE DESIGNEE OR TO THE OWNER OR LESSEE IF THE DESIGNEE IS NOT NAMED OR HAS DIED.

WARNING TO DEPONENT: A PERSON, WHO WITH INTENT TO DEFRAUD, GIVES A FALSE SWORN STATEMENT IS SUBJECT TO CRIMINAL PENALTIES AS PROVIDED IN SECTION 110 OF THE MICHIGAN CONSTRUCTION LIEN ACT, ACT NO. 497 OF THE PUBLIC ACTS OF 1980, AS AMENDED, BEING SECTION 570.1110 OF THE MICHIGAN COMPLIED LAWS.

_____ (Deponent). Subscribed and sworn to me this _____ day of _____.

_____ Notary Public, _____ County Michigan- My commission expires _____.



**Oakland County Community and Home Improvement Division
FULL UNCONDITIONAL WAIVER**

Technician Name: _____

Oakland County File Number: _____

My/our contract with _____

To provide _____

For an improvement to the property described as:

HAVE BEEN FULLY PAID AND SATISFIED, ALL MY/OUR CONSTRUCTION
LEIN RIGHTS AGAINST SUBJECT PROPERTY ARE HEREBY WAIVED
AND RELEASED.

Company name: _____

Company address: _____

Legal signature of lien claimant: _____

Name printed: _____

Date: _____

This page is located on the U.S. Department of Housing and Urban Development's Homes and Communities website at https://www.hud.gov/program_offices/davis_bacon_and_labor_standards/olr_9601.



Labor Standards Compliance Requirements

-  Information by State
-  Print version

Date: December 2, 1996

(Rev 1) Letter No. LR-96-01

Subject: **Labor standards compliance requirements for self-employed laborers and mechanics (aka *Working Subcontractors*)**

- I. HUD policy on prevailing wage applicability.**
- II. Compliance and certification parameters.**
- III. Owners of businesses working with their crews.**
- IV. Owner-Operators of power equipment.**
- V. Truck drivers.**

The Federal prevailing wage requirements and compliance standards for self-employed laborers and mechanics (also referred to as "working subcontractors") have long been a confusing and contentious area for the Department of Labor (DOL), HUD, the Internal Revenue Service and contractors and subcontractors.

The following policy represents an effort to provide practical guidance for field application. The guidance more specifically concerns the wage certification requirements for self-employed mechanics and laborers on projects subject to Federal labor standards provisions including Davis-Bacon and HUD-determined maintenance and nonroutine maintenance prevailing wage rate determinations. This policy does not attempt to establish whether working subcontractors are subject to Federal labor standards nor whether such working subcontractors are *bona fide*. The clear meaning of statutory provisions and regulatory definitions does not require further examination of applicability. Additionally, statutory and regulatory language are clear that the question of whether certain self-employed laborers and mechanics are *bona fide* subcontractors is not germane to the issue of prevailing wage standard applicability.

Page 2

Letter No. LR-96-01

I. HUD policy on prevailing wage applicability.

The Davis-Bacon Act (DBA), HUD program Related Acts (DBRA) concerning the payment of prevailing wages as determined by the Secretary of Labor, and the U.S. Housing Act of 1937 concerning the payment of prevailing wage rates established by HUD provide that the wage protections afforded in these statutes apply to laborers and mechanics employed on the covered work. The DBA and DBRA implementing regulations (29 CFR Part 5) specifically stipulate that these protections are provided **regardless of any contractual relationship which may be alleged to exist** between the contractor and such laborers and mechanics. Additionally, all laborers and mechanics must be paid unconditionally and not less often than once per week. HUD has followed DBA/DBRA prevailing wage parameters in its implementation, administration and enforcement of HUD-determined maintenance and nonroutine maintenance prevailing wage standards. (NOTE: The requirement to pay weekly wages is not applicable to the payment of

prevailing routine maintenance wage rates related to laborers and mechanics engaged in the operation of PHA and IHA housing developments.)

Therefore, it is HUD policy that in all cases where laborers and mechanics are employed on Federal prevailing wage-covered construction, maintenance and nonroutine maintenance work, laborers and mechanics shall be entitled to compensation (in the case of Davis-Bacon wages, *weekly* compensation) at wage rates not less than the prevailing rate for the type of work they perform **regardless of any contractual relationship alleged to exist between a contractor or subcontractor and such laborers or mechanics.**

The above policy statement is not a departure from previous HUD directives. The guidance presented below establishes uniform HUD-assisted program contract administration and enforcement parameters for labor standards compliance and prevailing wage certification.

II. Compliance and certification parameters.

HUD policy clearly affords prevailing wage protection for all laborers and mechanics, regardless of contractual relationship. There is no exception to this protection for self-employed laborers or mechanics, including owners of businesses, sole-proprietors, partners, corporate officers, or others. This policy in no way precludes or limits any business or individual from participating in HUD-assisted construction, maintenance, or nonroutine maintenance work. The

Page 3 Letter

No. LR-96-01

issue is not one of *eligibility*, whether such persons are permitted to work on HUD-assisted projects, but of compliance standards - what HUD will accept from contractors and subcontractors to demonstrate that proper compliance has been achieved.

In this context, this Letter establishes a HUD administrative policy that laborers and mechanics may not certify to the payment of their **own** prevailing wages **EXCEPT** where the laborer or mechanic is the owner of a business working on the site of the work with his/her own crew. (This exception is described in detail in Paragraph III. Owner-operators of power equipment are discussed in Paragraph IV; Truck drivers are discussed in Paragraph V.)

The most frequent occurrence of self-employed workers on HUD-assisted projects involves mechanic/trade classifications (i.e., not laborer classifications). (For ease of reference, laborers and mechanics in this context are referred to as "mechanics" and include any case involving laborers.) These mechanics may be represented as sole-proprietors, self-employed mechanics, partners, or corporate officers - all with no direct employees engaged in the covered work.

Accordingly, HUD, and program participants responsible for labor standards administration and enforcement (e.g., PHAs, IHAs, CDBG recipients), may not accept certified payrolls reporting single or multiple owners (e.g., partners) certifying that they have paid to themselves the prevailing wage for their craft. For example, a sole-proprietor may not submit a payroll reporting himself or herself as simply "Owner" signing the certification as to his/her own wage payment from "draws" or other payment methods. Neither may several mechanics submit a payroll reporting themselves as "partners" with one or more certifying as to the payment of their wages or salaries. Such mechanics must instead be carried on the certified payroll of the contractor or subcontractor (the "responsible employer") for whom they are working and with whom they have executed a "contract" for services.

In these cases, maintenance of an accurate accounting of weekly work hours including any overtime hours for such mechanics is essential. Whatever method of compensation computation is utilized (piecework, weekly contract draw for

performance), the amount of weekly compensation divided by the actual hours of work performed for that week must result in an "effective" hourly wage rate for that week that is not less than the prevailing hourly rate for the type of work involved. This computation must take into account overtime pay rates (i.e., one and one half) for all hours worked in excess of 40 hours per

Page 4**Letter No. LR-96-01**

week, pursuant to the Contract Work Hours and Safety Standards Act (CWHSSA), where applicable, and pursuant to the Fair Labor Standards Act where CWHSSA is not applicable.

The name, work classification, actual hours of work, effective hourly wage rate, and wage payment for each such mechanic must be reported and certified on the responsible employer's weekly payroll. Note that the effective hourly wage rate for such mechanics may fluctuate from week to week. However, the effective hourly wage rate **may not** be less than the minimum prevailing rate for the respective craft. In any case where the effective rate falls below the corresponding craft prevailing wage rate, the responsible employer must compensate the mechanic at no less than the prevailing rate on the wage determination for that craft.

III. Owners of businesses working with their crew.

Owners of businesses working with their crew on the same HUD-assisted job site may certify to the payment of their own prevailing wages in conjunction with the prevailing wages paid to their employees. This exception to reporting standards *does not* suggest that such owners are not likewise entitled to prevailing wages for their labor. Rather, it accepts the wage payment certification on weekly payroll reports by the owner for his/her own wages as that certification *accompanies* the certification offered for the payment of prevailing wages to his/her employees. Such owners need only list their name, work classification including "owner," and the daily and total hours worked. (Such owners *do not* need to list a rate of pay or amounts earned.)

IV. Owner-operators of power equipment.

Frequently, *owner-operators of power equipment* (e.g., backhoes, front-end loaders) will contract for services at a rate for both "man and machine." In these cases, the owner-operator includes liability, equipment maintenance, and salary in an hourly or contract rate for services. Because of the prevalence of such practice and the inherent difficulty in ascribing costs for liability and maintenance costs versus hourly *labor* salary, HUD and its program clients may accept a combined ("man and machine") hourly rate on the responsible contractor's certified payroll provided that such hourly rate may not be less than the rate on the wage determination for the respective power equipment operator.

Page 5**Letter No. LR-96-01**

Note: Owner-operators of power equipment, like self-employed mechanics, may not submit their own payrolls certifying to the payment of their own wages BUT must be carried on the responsible contractor's certified payroll report.

V. Truck drivers.

As outlined earlier in this Letter, a DOL administrative policy excludes *bona fide owner-operators of trucks who are independent contractors* from DBRA/CWHSSA provisions concerning their own hours of work and rate(s) of pay. These truck "owner-operators" must be reported on weekly payrolls *but* the payrolls do not need to show the hours worked or rates - only the notation "Owner-operator."

Note that any laborers or mechanics, including truck drivers, employed by the owner-operator/independent contractor are subject to DBRA/CWHSSA provisions

in the usual manner.

This policy **does not** pertain to owner-operators of other equipment such as backhoes, bulldozers, cranes and scrapers (i.e., power equipment as noted in paragraph IV, above).

These compliance standards shall take effect immediately. Any exceptions to these standards must be approved in advance in writing by HUD Headquarters Office of Labor Relations.

Any questions concerning this *Letter* may be directed to the Office of Labor Relations at (202)708-0370 or, in the case of HUD program participants, to the HUD Field Labor Relations Staff with jurisdiction for your area.

Visit the Office of Labor Relations on the World Wide Web HUD Home Page

Return to OLR letters

Content current as of 11 March 2003

U.S. Department of Housing and Urban Development
451 7th Street, S.W., Washington, DC 20410
Telephone: (202) 708-1112 [Find the address of a HUD office near you](#)

Section 3 clause 135.38

All section 3 covered contracts shall include the following clause (referred to as the section 3 clause):

- A. The work to be performed under this contract is subject to the requirements of section 3 of the Housing and Urban Development Act of 1968, as amended, 12 U.S.C. 1701u (section 3). The purpose of section 3 is to ensure that employment and other economic opportunities generated by HUD assistance or HUD-assisted projects covered by section 3, shall, to the greatest extent feasible, be directed to low- and very low-income persons, particularly persons who are recipients of HUD assistance for housing.
- B. The parties to this contract agree to comply with HUD's regulations in 24 CFR part 135, which implement section 3. As evidenced by their execution of this contract, the parties to this contract certify that they are under no contractual or other impediment that would prevent them from complying with the part 135 regulations.
- C. The contractor agrees to send to each labor organization or representative of workers with which the contractor has a collective bargaining agreement or other understanding, if any, a notice advising the labor organization or workers' representative of the contractor's commitments under this section 3 clause, and will post copies of the notice in conspicuous places at the work site where both employees and applicants for training and employment positions can see the notice. The notice shall describe the section 3 preference, shall set forth minimum number and job titles subject to hire, availability of apprenticeship and training positions, the qualifications for each; and the name and location of the person(s) taking applications for each of the positions; and the anticipated date the work shall begin.
- D. The contractor agrees to include this section 3 clause in every subcontract subject to compliance with regulations in 24 CFR part 135, and agrees to take appropriate action, as provided in an applicable provision of the subcontract or in this section 3 clause, upon a finding that the subcontractor is in violation of the regulations in 24 CFR part 135. The contractor will not subcontract with any subcontractor where the contractor has notice or knowledge that the subcontractor has been found in violation of the regulations in 24 CFR part 135.
- E. The contractor will certify that any vacant employment positions, including training positions, that are filled (1) after the contractor is selected but before the contract is executed, and (2) with persons other than those to whom the regulations of 24 CFR part 135 require employment opportunities to be directed, were not filled to circumvent the contractor's obligations under 24 CFR part 135.
- F. Noncompliance with HUD's regulations in 24 CFR part 135 may result in sanctions, termination of this contract for default, and debarment or suspension from future HUD assisted contracts.
- G. With respect to work performed in connection with section 3 covered Indian housing assistance, section 7(b) of the Indian Self-Determination and Education Assistance Act (25 U.S.C. 450e) also applies to the work to be performed under this contract. Section 7(b) requires that to the greatest extent feasible (i) preference and opportunities for training and employment shall be given to Indians, and (ii) preference in the award of contracts and subcontracts shall be given to Indian organizations and Indian-owned Economic Enterprises. Parties to this contract that are subject to the provisions of section

3 and section 7(b) agree to comply with section 3 to the maximum extent feasible, but not in derogation of compliance with section 7(b).

"General Decision Number: MI20210001 05/07/2021

Superseded General Decision Number: MI20200001

State: Michigan

Construction Types: Highway (Highway, Airport & Bridge xxxxx and Sewer/Incid. to Hwy.)

Counties: Michigan Statewide.

Note: Under Executive Order (EO) 13658, an hourly minimum wage of \$10.95 for calendar year 2021 applies to all contracts subject to the Davis-Bacon Act for which the contract is awarded (and any solicitation was issued) on or after January 1, 2015. If this contract is covered by the EO, the contractor must pay all workers in any classification listed on this wage determination at least \$10.95 per hour (or the applicable wage rate listed on this wage determination, if it is higher) for all hours spent performing on the contract in calendar year 2021. If this contract is covered by the EO and a classification considered necessary for performance of work on the contract does not appear on this wage determination, the contractor must pay workers in that classification at least the wage rate determined through the conformance process set forth in 29 CFR 5.5(a)(1)(ii) (or the EO minimum wage rate, if it is higher than the conformed wage rate). The EO minimum wage rate will be adjusted annually. Please note that this EO applies to the above-mentioned types of contracts entered into by the federal government that are subject to the Davis-Bacon Act itself, but it does not apply to contracts subject only to the Davis-Bacon Related Acts, including those set forth at 29 CFR 5.1(a)(2)-(60). Additional information on contractor requirements and worker protections under the EO is available at www.dol.gov/whd/govcontracts.

| Modification Number | Publication Date |
|---------------------|------------------|
| 0 | 01/01/2021 |
| 1 | 03/12/2021 |
| 2 | 05/07/2021 |

CARP0004-004 06/01/2019

REMAINDER OF STATE

| | Rates | Fringes |
|------------------------------|----------|---------|
| CARPENTER (Piledriver)..... | \$ 27.62 | 20.59 |

CARP0004-005 06/01/2018

LIVINGSTON (Townships of Brighton, Deerfield, Genoa, Hartland, Oceola & Tyrone), MACOMB, MONROE, OAKLAND, SANILAC, ST. CLAIR AND WAYNE COUNTIES

| | Rates | Fringes |
|-----------------------------|----------|---------|
| CARPENTER (Piledriver)..... | \$ 30.50 | 27.28 |

ELEC0017-005 06/01/2020

STATEWIDE

| | Rates | Fringes |
|---|----------|---------|
| Line Construction | | |
| Groundman/Driver..... | \$ 28.84 | 16.03 |
| Journeyman Signal Tech, Communications Tech, Tower Tech & Fiber Optic Splicers. | \$ 41.44 | 20.00 |
| Journeyman Specialist..... | \$ 47.66 | 21.96 |
| Operator A..... | \$ 35.02 | 17.99 |
| Operator B..... | \$ 32.69 | 17.25 |

Classifications

Journeyman Specialist: Refers to a crew of only one person working alone.

Operator A: Shall be proficient in operating all power equipment including: Backhoe, Excavator, Directional Bore and Boom/Digger truck.

Operator B: Shall be proficient in operating any 2 of the above mentioned pieces of equipment listed under Operator A.

ENGI0324-003 06/01/2020

ALCONA, ALPENA, ARENAC, BAY, CHEBOYGAN, CLARE, CLINTON, CRAWFORD, GENESEE, GLADWIN, GRATIOT, HURON, INGHAM, IOSCO, ISABELLA, JACKSON, LAPEER, LENAWEE, LIVINGSTON, MACOMB, MIDLAND, MONROE, MONTMORENCY, OAKLAND, OGEMAW, OSCODA, OTSEGO, PRESQUE ISLE, ROSCOMMON, SAGINAW, ST. CLAIR, SANILAC, SHIAWASSEE, TUSCOLA, WASHTENAW AND WAYNE COUNTIES:

| | Rates | Fringes |
|---|----------|---------|
| OPERATOR: Power Equipment (Steel Erection) | | |
| GROUP 1..... | \$ 47.02 | 24.85 |
| GROUP 2..... | \$ 48.02 | 24.85 |
| GROUP 3..... | \$ 45.52 | 24.85 |
| GROUP 4..... | \$ 46.52 | 24.85 |
| GROUP 5..... | \$ 44.02 | 24.85 |
| GROUP 6..... | \$ 45.02 | 24.85 |
| GROUP 7..... | \$ 43.75 | 24.85 |
| GROUP 8..... | \$ 44.75 | 24.85 |
| GROUP 9..... | \$ 43.30 | 24.85 |
| GROUP 10..... | \$ 44.30 | 24.85 |
| GROUP 11..... | \$ 42.57 | 24.85 |
| GROUP 12..... | \$ 43.57 | 24.85 |
| GROUP 13..... | \$ 42.21 | 24.85 |
| GROUP 14..... | \$ 43.21 | 24.85 |
| GROUP 15..... | \$ 41.57 | 24.85 |
| GROUP 16..... | \$ 38.62 | 24.85 |
| GROUP 17..... | \$ 24.14 | 12.00 |
| GROUP 18..... | \$ 27.63 | 12.00 |

FOOTNOTE:

Paid Holidays: New Year's Day, Memorial Day, Fourth of July, Labor Day, Thanksgiving Day and Christmas Day.

POWER EQUIPMENT OPERATOR CLASSIFICATIONS

- GROUP 1: Engineer when operating combination of boom and jib 400' or longer
- GROUP 2: Engineer when operating combination of boom and jib 400' or longer on a crane that requires an oiler
- GROUP 3: Engineer when operating combination of boom and jib 300' or longer
- GROUP 4: Engineer when operating combination of boom and jib 300' or longer on a crane that requires an oiler
- GROUP 5: Engineer when operating combination of boom and jib 220' or longer
- GROUP 6: Engineer when operating combination of boom and jib 220' or longer on a crane that requires an oiler
- GROUP 7: Engineer when operating combination of boom and jib 140' or longer
- GROUP 8: Engineer when operating combination of boom and jib 140' or longer on a crane that requires an oiler
- GROUP 9: Tower crane & derrick operator (where operator's work station is 50 ft. or more above first sub-level)
- GROUP 10: Tower crane & derrick operator (where operator's work station is 50 ft. or more above first sub-level) on a crane that requires an oiler
- GROUP 11: Engineer when operating combination of boom and jib 120' or longer
- GROUP 12: Engineer when operating combination of boom and jib 120' or longer on a crane that requires an oiler
- GROUP 13: Crane operator; job mechanic and 3 drum hoist and excavator
- GROUP 14: Crane operator on a crane that requires an oiler
- GROUP 15: Hoisting operator; 2 drum hoist and rubber tired backhoe
- GROUP 16: Forklift and 1 drum hoist
- GROUP 17: Compressor or welder operator
- GROUP 18: Oiler

ENGI0324-004 06/01/2020

AREA 1: ALLEGAN, BARRY, BERRIEN, BRANCH, CALHOUN, CASS, EATON, HILLSDALE, IONIA, KALAMAZOO, KENT, LAKE, MANISTEE, MASON, MECOSTA, MONTCALM, MUSKEGON, NEWAYGO, OCEANA, OSCEOLA, OTTAWA, ST. JOSEPH, VAN BUREN

AREA 2: ANTRIM, BENZIE, CHARLEVOIX, EMMET, GRAND TRAVERSE, KALKASKA, LEELANAU, MISSAUKEE AND WEXFORD COUNTIES:

Rates

Fringes

OPERATOR: Power Equipment
(Steel Erection)

AREA 1

| | | |
|--------------|----------|-------|
| GROUP 1..... | \$ 47.02 | 24.85 |
| GROUP 2..... | \$ 43.75 | 24.85 |
| GROUP 3..... | \$ 42.21 | 24.85 |
| GROUP 4..... | \$ 38.62 | 24.85 |
| GROUP 5..... | \$ 24.14 | 12.00 |
| GROUP 6..... | \$ 27.63 | 12.00 |

AREA 2

| | | |
|--------------|----------|-------|
| GROUP 1..... | \$ 47.02 | 24.85 |
| GROUP 2..... | \$ 43.75 | 24.85 |
| GROUP 3..... | \$ 42.21 | 24.85 |
| GROUP 4..... | \$ 38.62 | 24.85 |
| GROUP 5..... | \$ 24.14 | 12.00 |
| GROUP 6..... | \$ 27.63 | 12.00 |

FOOTNOTES:

Crane operator with main boom and jib 300' or longer: \$1.50 additional to the group 1 rate. Crane operator with main boom and jib 400' or longer: \$3.00 additional to the group 1 rate.

PAID HOLIDAYS: New Year's Day, Memorial Day, Fourth of July, Labor Day, Thanksgiving Day and Christmas Day.

POWER EQUIPMENT OPERATOR CLASSIFICATIONS:

GROUP 1: Crane Operator with main boom & jib 400', 300', or 220' or longer.

GROUP 2: Crane Operator with main boom & jib 140' or longer, Tower Crane; Gantry Crane; Whirley Derrick.

GROUP 3: Regular Equipment Operator, Crane, Dozer, Loader, Hoist, Straddle Wagon, Mechanic, Grader and Hydro Excavator.

GROUP 4: Air Tugger (single drum), Material Hoist Pump 6" or over, Elevators, Brokk Concrete Breaker.

GROUP 5: Air Compressor, Welder, Generators, Conveyors

GROUP 6: Oiler and fire tender

ENGI0324-005 09/01/2020

AREA 1: GENESEE, LAPEER, LIVINGSTON, MACOMB, MONROE, OAKLAND, ST. CLAIR, WASHTENAW AND WAYNE COUNTIES

AREA 2: ALCONA, ALLEGAN, ALGER, ALPENA, ANTRIM, ARENAC, BARAGA, BARRY, BAY, BENZIE, BERRIEN, BRANCH, CALHOUN, CASS, CHARLEVOIX, CHEBOYGAN, CHIPPEWA, CLARE, CLINTON, CRAWFORD, DELTA, DICKINSON, EATON, EMMET, GLADWIN, GOGEBIC, GRAND TRAVERSE, GRATIOT, HILLSDALE, HOUGHTON, HURON, INGHAM, IONIA, IOSCO, IRON, ISABELLA, JACKSON, KALAMAZOO, KALKASKA, KENT, KWEENAW, LAKE, LEELANAU, LENAWEE, LUCE, MACKINAC, MANISTEE, MARQUETTE, MASON, MECOSTA, MENOMINEE, MIDLAND, MISSAUKEE, MONTCALM, MONTMORENCY, MUSKEGON, NEWAYGO, OCEANA, OGEMAW, ONTONAGON, OSCEOLA, OSCODA, OTSEGO, OTTAWA, PRESQUE ISLE, ROSCOMMON, SAGINAW, SANILAC, SCHOOLCRAFT, SHIAWASSEE, ST. JOSEPH, TUSCOLA, VAN BUREN AND WEXFORD COUNTIES

Rates

Fringes

OPERATOR: Power Equipment
 (Underground construction
 (including sewer))

AREA 1:

| | | |
|--------------|----------|-------|
| GROUP 1..... | \$ 35.88 | 24.85 |
| GROUP 2..... | \$ 31.15 | 24.85 |
| GROUP 3..... | \$ 30.42 | 24.85 |
| GROUP 4..... | \$ 29.85 | 24.85 |
| GROUP 5..... | \$ 21.40 | 12.05 |

AREA 2:

| | | |
|--------------|----------|-------|
| GROUP 1..... | \$ 34.17 | 24.85 |
| GROUP 2..... | \$ 29.28 | 24.85 |
| GROUP 3..... | \$ 28.78 | 24.85 |
| GROUP 4..... | \$ 28.50 | 24.85 |
| GROUP 5..... | \$ 21.40 | 12.05 |

POWER EQUIPMENT OPERATOR CLASSIFICATIONS

GROUP 1: Backfiller tamper; Backhoe; Batch plant operator (concrete); Clamshell; Concrete paver (2 drums or larger); Conveyor loader (Euclid type); Crane (crawler, truck type or pile driving); Dozer; Dragline; Elevating grader; Endloader; Gradall (and similar type machine); Grader; Mechanic; Power shovel; Roller (asphalt); Scraper (self-propelled or tractor drawn); Side boom tractor (type D-4 or equivalent and larger); Slip form paver; Slope paver; Trencher (over 8 ft. digging capacity); Well drilling rig; Concrete pump with boom operator; Hydro Excavator

GROUP 2: Boom truck (power swing type boom); Crusher; Hoist; Pump (1 or more - 6-in. discharge or larger - gas or diesel- powered or powered by generator of 300 amperes or more - inclusive of generator); Side boom tractor (smaller than type D-4 or equivalent); Tractor (pneu-tired, other than backhoe or front end loader); Trencher (8-ft. digging capacity and smaller); Vac Truck and End dump operator;

GROUP 3: Air compressors (600 cfm or larger); Air compressors (2 or more-less than 600 cfm); Boom truck (non-swinging, non- powered type boom); Concrete breaker (self-propelled or truck mounted - includes compressor); Concrete paver (1 drum-1/2 yd. or larger); Elevator (other than passenger); Maintenance person; Pump (2 or more-4-in. up to 6-in. discharge-gas or diesel powered - excluding submersible pumps); Pumpcrete machine (and similar equipment); Wagon drill (multiple); Welding machine or generator (2 or more-300 amp. or larger - gas or diesel powered)

GROUP 4: Boiler; Concrete saw (40 hp or over); Curing machine (self-propelled); Farm tractor (with attachment); Finishing machine (concrete); Hydraulic pipe pushing machine; Mulching equipment; Pumps (2 or more up to 4-in. discharge, if used 3 hours or more a day, gas or diesel powered - excluding submersible pumps); Roller (other than asphalt); Stump remover; Trencher (service); Vibrating compaction equipment, self-propelled (6 ft. wide or over); Sweeper (Wayne type); Water wagon and Extend-a boom forklift

Group 5: Fire Person, Oiler

GENESEE, MACOMB, MONROE, OAKLAND, WASHTENAW, WAYNE, ALCONA, ALGER, ALLEGAN, ALPENA, ANTRIM, ARENAC, BARAGA, BARRY, BAY, BENZIE, BERRIEN, BRANCH, CALHOUN, CASS, CHARLEVOIX, CHEBOYGAN, CHIPPEWA, CLARE, CLINTON, CRAWFORD, DELTA, DICKINSON, EATON, EMMET, GLADWIN, GOGEBIC, GRAND TRAVERSE, GRATIOT, HILLSDALE, HOUGHTON, HURON, INGHAM, IONIA, IOSCO, IRON, ISABELLA, JACKSON, KALAMAZOO, KALKASKA, KENT, KEWEENAW, LAKE, LAPEER, LEELANAU, LENAWEE, LIVINGSTON, LUCE, MACKINAC, MANISTEE, MARQUETTE, MASON, MECOSTA, MENOMINEE, MIDLAND, MISSAUKEE, MONTCALM, MONTMORENCY, MUSKEGON, NEWAYGO, OCEANA, OGEMAW, ONTONAGON, OSCEOLA, OSCODA, OTSEGO, OTTAWA, PRESQUE ISLE, ROSCOMMON, SAGINAW, ST. CLARE, ST. JOSEPH, SANILAC, SCHOOLCRAFT, SHIAWASSEE, TUSCOLA, VAN BUREN AND WEXFORD COUNTIES

| | Rates | Fringes |
|--|----------|---------|
| Power equipment operators: (AIRPORT, BRIDGE & HIGHWAY CONSTRUCTION) | | |
| GROUP 1..... | \$ 36.86 | 24.85 |
| GROUP 2..... | \$ 28.18 | 24.85 |
| GROUP 3..... | \$ 27.62 | 24.85 |
| GROUP 4..... | \$ 27.45 | 24.85 |

POWER EQUIPMENT OPERATOR CLASSIFICATIONS

GROUP 1: Asphalt plant operator; Crane operator (does not include work on bridge construction projects when the crane operator is erecting structural components); Dragline operator; Shovel operator; Locomotive operator; Paver operator (5 bags or more); Elevating grader operator; Pile driving operator; Roller operator (asphalt); Blade grader operator; Trenching machine operator (ladder or wheel type); Auto-grader; Slip form paver; Self-propelled or tractor-drawn scraper; Conveyor loader operator (Euclid type); Endloader operator (1 yd. capacity and over); Bulldozer; Hoisting engineer; Tractor operator; Finishing machine operator (asphalt); Mechanic; Pump operator (6-in. discharge or over, gas, diesel powered or generator of 300 amp. or larger); Shouldering or gravel distributing machine operator (self-propelled); Backhoe (with over 3/8 yd. bucket); Side boom tractor (type D-4 or equivalent or larger); Tube finisher (slip form paving); Gradall (and similar type machine); Asphalt paver (self-propelled); Asphalt planer (self-propelled); Batch plant (concrete-central mix); Slurry machine (asphalt); Concrete pump (3 in. and over); Roto-mill; Swinging boom truck (over 12 ton capacity); Hydro demolisher (water blaster); Farm-type tractor with attached pan; Vacuum truck operator; Batch Plant (concrete dry batch); Concrete Saw Operator (40h.p. or over; Tractor Operator (farm type); Finishing Machine Operator (concrete); Grader Operator (self-propelled fine grade or form (concrete)).

GROUP 2: Screening plant operator; Washing plant operator; Crusher operator; Backhoe (with 3/8 yd. bucket or less); Side boom tractor (smaller than D-4 type or equivalent); Sweeper (Wayne type and similar equipment); Greese Truck; Air Compressor Operator (600 cu.ft. per min or more); Air Compressor Operator (two or more, less than 600 cfm);

GROUP 3: Boiler fire tender; Tractor operator (farm type with attachment); Concrete Breaker; Wagon Drill Operator;

GROUP 4: Oiler; Fire tender; Trencher (service); Flexplane operator; Cleftplane operator; Boom or winch hoist truck operator; Endloader operator *under 1 yd. capacity); Roller Operator (other than asphalt); Curing equipment operator (self-propelled); Power bin operator; Plant drier (6 ft. wide or over); Guard post driver operator (power driven); All mulching equipment; Stump remover; Concrete pump (under 3-in.); Mesh installer (self-propelled); End dump; Skid Steer.

 ENGI0324-007 05/01/2020

ALGER, BARAGA, CHIPPEWA, DELTA, DICKINSON, GOGEBIC, HOUGHTON, IRON, KEWEENAW, LUCE, MACKINAC MARQUETTE, MENOMINEE, ONTONAGON AND SCHOOLCRAFT COUNTIES:

| | Rates | Fringes |
|--|----------|---------|
| OPERATOR: Power Equipment (Steel Erection) | | |
| Compressor, welder and forklift..... | \$ 33.90 | 24.60 |
| Crane operator, main boom & jib 120' or longer..... | \$ 40.37 | 24.60 |
| Crane operator, main boom & jib 140' or longer..... | \$ 40.67 | 24.60 |
| Crane operator, main boom & jib 220' or longer..... | \$ 41.26 | 24.60 |
| Mechanic with truck and tools..... | \$ 39.50 | 24.60 |
| Oiler and fireman..... | \$ 32.36 | 24.60 |
| Regular operator..... | \$ 37.72 | 24.60 |

 ENGI0324-008 10/01/2020

ALCONA, ALGER, ALLEGAN, ALPENA, ANTRIM, ARENAC, BARAGA, BARRY, BAY, BENZIE, BERRIEN, BRANCH, CALHOUN, CASS, CHARLEVOIX, CHEBOYGAN, CHIPPEWA, CLARE, CLINTON, CRAWFORD, DELTA, DICKINSON, EATON, EMMET, GENESEE, GLADWIN, GOGEBIC, GRAND TRAVERSE, GRATIOT, HILLSDALE, HOUGHTON, HURON, INGHAM, IONIA, IOSCO, IRON, ISABELLA, JACKSON, KALAMAZOO, KALKASKA, KENT, KEWEENAW, LAKE, LAPEER, LEELANAU, LENAWEE, LIVINGSTON, LUCE, MACKINAC, MACOMB, MANISTEE, MARQUETTE, MASON, MECOSTA, MENOMINEE, MIDLAND, MISSAUKEE, MONTCALM, MONTMORENCY, MONROE, MUSKEGON, NEWAYGO, OAKLAND, OCEANA, OGEMAW, ONTONAGON, OSCEOLA, OSCODA, OTSEGO, OTTAWA, PRESQUE ISLE, ROSCOMMON, SAGINAW, ST. CLARE, ST. JOSEPH, SANILAC, SCHOOLCRAFT, SHIAWASSEE, TUSCOLA, VAN BUREN, WASHTENAW, WAYNE AND WEXFORD COUNTIES

| | Rates | Fringes |
|---|----------|---------|
| OPERATOR: Power Equipment (Sewer Relining) | | |
| GROUP 1..... | \$ 34.62 | 13.92 |
| GROUP 2..... | \$ 32.83 | 13.92 |

SEWER RELINING CLASSIFICATIONS

GROUP 1: Operation of audio-visual closed circuit TV system, including remote in-ground cutter and other equipment used in connection with the CCTV system

GROUP 2: Operation of hot water heaters and circulation systems, water jetters and vacuum and mechanical debris removal systems

 ENGI0325-012 05/01/2020

| | Rates | Fringes |
|--|----------|---------|
| Power equipment operators - gas distribution and duct installation work: | | |
| GROUP 1..... | \$ 32.18 | 24.85 |
| GROUP 2..... | \$ 32.06 | 24.85 |
| GROUP 3..... | \$ 30.35 | 24.85 |

SCOPE OF WORK: The construction, installation, treating and reconditioning of pipelines transporting gas vapors within cities, towns, subdivisions, suburban areas, or within private property boundaries, up to and including private meter settings of private industrial, governmental or other premises, more commonly referred to as "distribution work," starting from the first metering station, connection, similar or related facility, of the main or cross country pipeline and including duct installation.

Group 1: Backhoe, crane, grader, mechanic, dozer (D-6 equivalent or larger), side boom (D-4 equivalent or larger), trencher(except service), endloader (2 yd. capacity or greater).

GROUP 2: Dozer (less than D-6 equivalent), endloader (under 2 yd. capacity), side boom (under D-4 capacity), backfiller, pumps (1 or 2 of 6-inch discharge or greater), boom truck (with powered boom), tractor (wheel type other than backhoe or front endloader). Tamper (self-propelled), boom truck (with non-powered boom), concrete saw (20 hp or larger), pumps (2 to 4 under 6-inch discharge), compressor (2 or more or when one is used continuously into the second day) and trencher(service).

GROUP 3: Oiler, hydraulic pipe pushing machine, grease person and hydrostatic testing operator.

 IRON0008-007 06/01/2020

ALGER, BARAGA, CHIPPEWA, DELTA, DICKINSON, GOGEBIC, HOUGHTON, IRON, KEWEENAW, LUCE, MACKINAC MARQUETTE, MENOMINEE, ONTONAGON AND SCHOOLCRAFT COUNTIES:

| | Rates | Fringes |
|--|----------|---------|
| Ironworker - pre-engineered metal building erector..... | \$ 23.70 | 6.95 |
| IRONWORKER | | |
| General contracts | | |
| \$10,000,000 or greater..... | \$ 34.99 | 27.12 |
| General contracts less than \$10,000,000..... | \$ 34.99 | 27.12 |

Paid Holidays: New Year's Day, Memorial Day, July 4th, Labor Day, Thanksgiving Day & Christmas Day.

IRON0025-002 06/01/2019

ALCONA, ALPENA, ARENAC, BAY, CHEBOYGAN, CLARE, CLINTON,
CRAWFORD, GENESEE, GLADWIN, GRATIOT, HURON, INGHAM, IOSCO,
ISABELLA, JACKSON, LAPEER, LIVINGSTON, MACOMB, MIDLAND,
MONTMORENCY, OAKLAND, OGEMAW, OSCODA, OTSEGO, PRESQUE ISLE,
ROSCOMMON, SAGINAW, SANILAC, SHIAWASSEE, ST. CLAIR, TUSCOLA,
WASHTENAW AND WAYNE COUNTIES:

| | Rates | Fringes |
|---|----------|---------|
| Ironworker - pre-engineered metal building erector | | |
| Alcona, Alpena, Arenac, Cheboygan, Clare, Clinton, Crawford, Gladwin, Gratiot, Huron, Ingham, Iosco, Isabella, Jackson, Lapeer, Livingston (west of Burkhardt Road), Montmorency, Ogemaw, Oscoda, Otsego, Presque Isle, Roscommon, Sanilac, Shiawassee, Tuscola & Washtenaw (west of U.S. 23). | \$ 24.26 | 22.11 |
| Bay, Genesee, Lapeer, Livingston (east of Burkhardt Road), Macomb, Midland, Oakland, Saginaw, St. Clair, The University of Michigan, Washtenaw (east of U.S. 23) & Wayne... | \$ 25.48 | 23.11 |
| IRONWORKER | | |
| Ornamental and Structural... | \$ 36.77 | 29.03 |
| Reinforcing..... | \$ 30.98 | 27.99 |

IRON0055-005 07/01/2020

LENAWEE AND MONROE COUNTIES:

| | Rates | Fringes |
|--|----------|---------|
| IRONWORKER | | |
| Pre-engineered metal buildings..... | \$ 23.59 | 19.35 |
| All other work..... | \$ 31.00 | 25.60 |

IRON0292-003 06/01/2020

BERRIEN AND CASS COUNTIES:

| | Rates | Fringes |
|---|----------|---------|
| IRONWORKER (Including pre-engineered metal building erector)..... | \$ 31.75 | 22.84 |

IRON0340-001 06/19/2017

ALLEGAN, ANTRIM, BARRY, BENZIE, BRANCH, CALHOUN, CHARLEVOIX,
EATON, EMMET, GRAND TRAVERSE, HILLSDALE, IONIA, KALAMAZOO,
KALKASKA, KENT, LAKE, LEELANAU, MANISTEE, MASON, MECOSTA,
MISSAUKEE, MONTCALM, MUSKEGON, NEWAYGO, OCEANA, OSCEOLA,

OTTAWA, ST. JOSEPH, VAN BUREN AND WEXFORD COUNTIES:

| | Rates | Fringes |
|---|----------|---------|
| IRONWORKER (Including pre-engineered metal building erector)..... | \$ 24.43 | 24.67 |

LAB00005-006 10/01/2020

| | Rates | Fringes |
|---|----------|---------|
| Laborers - hazardous waste abatement: (ALCONA, ALPENA, ANTRIM, BENZIE, CHARLEVOIX, CHEBOYGAN, CRAWFORD, EMMET, GRAND TRAVERSE, IOSCO, KALKASKA, LEELANAU, MISSAUKEE, MONTMORENCY, OSCODA, OTSEGO, PRESQUE ISLE AND WEXFORD COUNTIES - Zone 10) | | |
| Levels A, B or C..... | \$ 17.45 | 12.75 |
| class b..... | \$ 18.64 | 12.90 |
| Work performed in conjunction with site preparation not requiring the use of personal protective equipment; | | |
| Also, Level D..... | \$ 16.45 | 12.75 |
| class a..... | \$ 17.64 | 12.90 |
| Zone 10 | | |
| Laborers - hazardous waste abatement: (ALGER, BARAGA, CHIPPEWA, DELTA, DICKINSON, GOGEBIC, HOUGHTON, IRON, KEWEENAW, LUCE, MACKINAC, MARQUETTE, MENOMINEE, ONTONAGON AND SCHOOLCRAFT COUNTIES - Zone 11) | | |
| Levels A, B or C..... | \$ 23.58 | 12.90 |
| Work performed in conjunction with site preparation not requiring the use of personal protective equipment; | | |
| Also, Level D..... | \$ 22.58 | 12.90 |
| Laborers - hazardous waste abatement: (ALLEGAN, BARRY, BERRIEN, BRANCH, CALHOUN, CASS, IONIA COUNTY (except the city of Portland); KALAMAZOO, KENT, LAKE, MANISTEE, MASON, MECOSTA, MONTCALM, MUSKEGON, NEWAYGO, OCEANA, OSCEOLA, OTTAWA, ST. JOSEPH AND VAN BUREN COUNTIES - Zone 9) | | |
| Levels A, B or C..... | \$ 21.80 | 12.90 |
| Work performed in conjunction with site preparation not requiring the use of personal protective equipment; | | |

| | |
|---|-------|
| Also, Level D.....\$ 20.80 | 12.90 |
| Laborers - hazardous waste abatement: (ARENAC, BAY, CLARE, GLADWIN, GRATIOT, HURON, ISABELLA, MIDLAND, OGEMAW, ROSCOMMON, SAGINAW AND TUSCOLA COUNTIES - Zone 8) | |
| Levels A, B or C.....\$ 21.39 | 12.90 |
| Work performed in conjunction with site preparation not requiring the use of personal protective equipment; | |
| Also, Level D.....\$ 20.80 | 12.90 |
| Laborers - hazardous waste abatement: (CLINTON, EATON AND INGHAM COUNTIES; IONIA COUNTY (City of Portland); LIVINGSTON COUNTY (west of Oak Grove Rd., including the City of Howell) - Zone 6) | |
| Levels A, B or C.....\$ 25.64 | 12.90 |
| Work performed in conjunction with site preparation not requiring the use of personal protective equipment; | |
| Also, Level D.....\$ 24.64 | 12.90 |
| Laborers - hazardous waste abatement: (GENESEE, LAPEER AND SHIAWASSEE COUNTIES - Zone 7) | |
| Levels A, B or C.....\$ 24.20 | 13.80 |
| Work performed in conjunction with site preparation not requiring the use of personal protective equipment; | |
| Also, Level D.....\$ 23.20 | 13.80 |
| Laborers - hazardous waste abatement: (HILLSDALE, JACKSON AND LENAWEЕ COUNTIES - Zone 4) | |
| Levels A, B or C.....\$ 25.17 | 12.90 |
| Work performed in conjunction with site preparation not requiring the use of personal protective equipment; | |
| Also, Level D.....\$ 24.17 | 12.90 |
| Laborers - hazardous waste abatement: (LIVINGSTON COUNTY (east of Oak Grove Rd. and south of M-59, excluding the city of Howell); AND WASHTENAW COUNTY - Zone 3) | |
| Levels A, B or C.....\$ 29.93 | 14.20 |
| Work performed in conjunction with site preparation not requiring the use of personal protective equipment; | |
| Also, Level D.....\$ 28.93 | 14.20 |
| Laborers - hazardous waste abatement: (MACOMB AND WAYNE | |

| | | |
|---|----------|-------|
| COUNTIES - Zone 1) | | |
| Levels A, B or C..... | \$ 29.93 | 16.90 |
| Work performed in conjunction with site preparation not requiring the use of personal protective equipment; | | |
| Also, Level D..... | \$ 28.93 | 16.90 |
| Laborers - hazardous waste abatement: (MONROE COUNTY - Zone 4) | | |
| Levels A, B or C..... | \$ 31.75 | 14.90 |
| Work performed in conjunction with site preparation not requiring the use of personal protective equipment; | | |
| Also, Level D..... | \$ 31.75 | 14.90 |
| Laborers - hazardous waste abatement: (OAKLAND COUNTY and the Northeast portion of LIVINGSTON COUNTY bordered by Oak Grove Road on the West and M-59 on the South - Zone 2) | | |
| Level A, B, C..... | \$ 29.93 | 16.90 |
| Work performed in conjunction with site preparation not requiring the use of personal protective equipment; | | |
| Also, Level D..... | \$ 28.93 | 16.90 |
| Laborers - hazardous waste abatement: (SANILAC AND ST. CLAIR COUNTIES - Zone 5) | | |
| Levels A, B or C..... | \$ 25.75 | 16.35 |
| Work performed in conjunction with site preparation not requiring the use of personal protective equipment; | | |
| Also, Level D..... | \$ 24.75 | 16.35 |

LAB00259-001 09/01/2018

AREA 1: MACOMB, OAKLAND AND WAYNE COUNTIES
AREA 2: ALCONA, ALGER, ALLEGAN, ALPENA, ANTRIM, ARENAC, BARAGA, BARRY, BAY, BENZIE, BERRIEN, BRANCH, CALHOUN, CASS, CHARLEVOIX, CHEBOYGAN, CHIPPEWA, CLARE, CLINTON, CRAWFORD, DELTA, DICKINSON, EATON, EMMET, GENESEE, GLADWIN, GOGEBIC, GRAND TRAVERSE, GRATIOT, HILLSDALE, HOUGHTON, HURON, INGHAM, IONIA, IOSCO, IRON, ISABELLA, JACKSON, KALAMAZOO, KALKASKA, KENT, KEWEENAW, LAKE, LAPEER, LEELANAU, LENAWEE, LIVINGSTON, LUCE, MACKINAC, MANISTEE, MARQUETTE, MASON, MECOSTA, MENOMINEE, MIDLAND, MISSAUKEE, MONROE, MONTCALM, MONTMORENCY, MUSKEGON, NEWAYGO, OCEANA, OGEAW, ONTONAGON, OSCEOLA, OSCODA, OTSEGO, OTTAWA, PRESQUE ISLE, ROSCOMMON, SAGINAW, ST. CLARE, ST. JOSEPH, SANILAC, SCHOOLCRAFT, SHIAWASSEE, TUSCOLA, VAN BUREN, WASHTENAW AND WEXFORD COUNTIES

Rates Fringes

Laborers - tunnel, shaft and caisson:

| | | |
|--------------|----------|-------|
| AREA 1 | | |
| GROUP 1..... | \$ 22.57 | 16.80 |
| GROUP 2..... | \$ 22.68 | 16.80 |
| GROUP 3..... | \$ 22.74 | 16.80 |
| GROUP 4..... | \$ 22.92 | 16.80 |
| GROUP 5..... | \$ 23.17 | 16.80 |
| GROUP 6..... | \$ 23.50 | 16.80 |
| GROUP 7..... | \$ 16.78 | 16.80 |
| AREA 2 | | |
| GROUP 1..... | \$ 24.10 | 12.85 |
| GROUP 2..... | \$ 24.19 | 12.85 |
| GROUP 3..... | \$ 24.29 | 12.85 |
| GROUP 4..... | \$ 24.45 | 12.85 |
| GROUP 5..... | \$ 24.71 | 12.85 |
| GROUP 6..... | \$ 25.02 | 12.85 |
| GROUP 7..... | \$ 17.29 | 12.85 |

SCOPE OF WORK: Tunnel, shaft and caisson work of every type and description and all operations incidental thereto, including, but not limited to, shafts and tunnels for sewers, water, subways, transportation, diversion, sewerage, caverns, shelters, aquifers, reservoirs, missile silos and steel sheeting for underground construction.

TUNNEL LABORER CLASSIFICATIONS

GROUP 1: Tunnel, shaft and caisson laborer, dump, shanty, hog house tender, testing (on gas) and watchman

GROUP 2: Manhole, headwall, catch basin builder, bricklayer tender, mortar machine and material mixer

GROUP 3: Air tool operator (jackhammer, bush hammer and grinder), first bottom, second bottom, cage tender, car pusher, carrier, concrete, concrete form, concrete repair, cement invert laborer, cement finisher, concrete shoveler, conveyor, floor, gasoline and electric tool operator, gunite, grout operator, welder, heading dinky person, inside lock tender, pea gravel operator, pump, outside lock tender, scaffold, top signal person, switch person, track, tigger, utility person, vibrator, winch operator, pipe jacking, wagon drill and air track operator and concrete saw operator (under 40 h.p.)

GROUP 4: Tunnel, shaft and caisson mucker, bracer, liner plate, long haul dinky driver and well point

GROUP 5: Tunnel, shaft and caisson miner, drill runner, key board operator, power knife operator, reinforced steel or mesh (e.g. wire mesh, steel mats, dowel bars, etc.)

GROUP 6: Dynamite and powder

GROUP 7: Restoration laborer, seeding, sodding, planting, cutting, mulching and top soil grading; and the restoration of property such as replacing mailboxes, wood chips, planter boxes, flagstones, etc.

LAB00334-001 09/01/2018

Rates Fringes

Laborers - open cut:
ZONE 1 - MACOMB, OAKLAND

AND WAYNE COUNTIES:

| | | |
|--------------|----------|-------|
| GROUP 1..... | \$ 22.42 | 16.80 |
| GROUP 2..... | \$ 22.53 | 16.80 |
| GROUP 3..... | \$ 22.58 | 16.80 |
| GROUP 4..... | \$ 22.66 | 16.80 |
| GROUP 5..... | \$ 22.72 | 16.80 |
| GROUP 6..... | \$ 20.17 | 16.80 |
| GROUP 7..... | \$ 16.79 | 16.80 |

ZONE 2 - LIVINGSTON COUNTY

(east of M-151 (Oak Grove Rd.)); MONROE AND

WASHTENAW COUNTIES:

| | | |
|--------------|----------|-------|
| GROUP 1..... | \$ 23.75 | 12.85 |
| GROUP 2..... | \$ 23.86 | 12.85 |
| GROUP 3..... | \$ 23.98 | 12.85 |
| GROUP 4..... | \$ 24.05 | 12.85 |
| GROUP 5..... | \$ 24.20 | 12.85 |
| GROUP 6..... | \$ 21.50 | 12.85 |
| GROUP 7..... | \$ 18.14 | 12.85 |

ZONE 3 - CLINTON, EATON,

GENESEEE, HILLSDALE AND INGHAM COUNTIES; IONIA

COUNTY (City of Portland);

JACKSON, LAPEER AND

LENAWEE COUNTIES;

LIVINGSTON COUNTY (west of M-151 Oak Grove Rd.);

SANILAC, ST. CLAIR AND

SHIAWASSEE COUNTIES:

| | | |
|--------------|----------|-------|
| GROUP 1..... | \$ 21.94 | 12.85 |
| GROUP 2..... | \$ 22.08 | 12.85 |
| GROUP 3..... | \$ 22.20 | 12.85 |
| GROUP 4..... | \$ 22.25 | 12.85 |
| GROUP 5..... | \$ 22.39 | 12.85 |
| GROUP 6..... | \$ 19.69 | 12.85 |
| GROUP 7..... | \$ 16.84 | 12.85 |

ZONE 4 - ALCONA, ALLEGAN,

ALPENA, ANTRIM, ARENAC,

BARRY, BAY, BENZIE,

BERRIEN, BRANCH,

CALHOUN, CASS, CHARLEVOIX,

CHEBOYGAN, CLARE,

CRAWFORD, EMMET,

GLADWIN, GRAND TRAVERSE,

GRATIOT AND HURON

COUNTIES; IONIA COUNTY

(EXCEPT THE CITY OF

PORTLAND); IOSCO,

ISABELLA, KALAMAZOO,

KALKASKA, KENT,

LAKE, LEELANAU, MANISTEE,

MASON, MECOSTA, MIDLAND,

MISSAUKEE, MONTCALM,

MONTMORENCY, MUSKEGON,

NEWAYGO, OCEANA, OGEMAW,

OSCEOLA, OSCODA, OTSEGO,

OTTAWA, PRESQUE ISLE,

ROSCOMMON, SAGINAW, ST.

JOSEPH, TUSCOLA, VAN BUREN

AND WEXFORD COUNTIES:

| | | |
|--------------|----------|-------|
| GROUP 1..... | \$ 20.97 | 12.85 |
| GROUP 2..... | \$ 21.10 | 12.85 |
| GROUP 3..... | \$ 21.21 | 12.85 |
| GROUP 4..... | \$ 21.28 | 12.85 |
| GROUP 5..... | \$ 21.40 | 12.85 |

| | | |
|---|----------|-------|
| GROUP 6..... | \$ 18.62 | 12.85 |
| GROUP 7..... | \$ 16.96 | 12.85 |
| ZONE 5 - ALGER, BARAGA, CHIPPEWA, DELTA, DICKINSON, GOGEBIC, HOUGHTON, IRON, KEWEENAW, LUCE, MACKINAC, MARQUETTE, MENOMINEE, ONTONAGON AND SCHOOLCRAFT COUNTIES: | | |
| GROUP 1..... | \$ 21.19 | 12.85 |
| GROUP 2..... | \$ 21.33 | 12.85 |
| GROUP 3..... | \$ 21.46 | 12.85 |
| GROUP 4..... | \$ 21.51 | 12.85 |
| GROUP 5..... | \$ 21.56 | 12.85 |
| GROUP 6..... | \$ 18.94 | 12.85 |
| GROUP 7..... | \$ 17.05 | 12.85 |

SCOPE OF WORK:

Open cut construction work shall be construed to mean work which requires the excavation of earth including industrial, commercial and residential building site excavation and preparation, land balancing, demolition and removal of concrete and underground appurtenances, grading, paving, sewers, utilities and improvements; retention, oxidation, flocculation and irrigation facilities, and also including but not limited to underground piping, conduits, steel sheeting for underground construction, and all work incidental thereto, and general excavation. For all areas except the Upper Peninsula, open cut construction work shall also be construed to mean waterfront work, piers, docks, seawalls, breakwalls, marinas and all incidental work. Open cut construction work shall not include any structural modifications, alterations, additions and repairs to buildings, or highway work, including roads, streets, bridge construction and parking lots or steel erection work and excavation for the building itself and back filling inside of and within 5 ft. of the building and foundations, footings and piers for the building. Open cut construction work shall not include any work covered under Tunnel, Shaft and Caisson work.

OPEN CUT LABORER CLASSIFICATIONS

GROUP 1: Construction laborer

GROUP 2: Mortar and material mixer, concrete form person, signal person, well point person, manhole, headwall and catch basin builder, headwall, seawall, breakwall and dock builder

GROUP 3: Air, gasoline and electric tool operator, vibrator operator, driller, pump person, tar kettle operator, bracer, rodder, reinforced steel or mesh person (e.g., wire mesh, steel mats, dowel bars, etc.), welder, pipe jacking and boring person, wagon drill and air track operator and concrete saw operator (under 40 h.p.), windlass and tugger person and directional boring person

GROUP 4: Trench or excavating grade person

GROUP 5: Pipe layer (including crock, metal pipe, multi-plate or other conduits)

GROUP 6: Grouting man, audio-visual television operations and all other operations in connection with closed circuit television inspection, pipe cleaning and pipe relining work and the installation and repair of water service pipe and appurtenances

GROUP 7: Restoration laborer, seeding, sodding, planting, cutting, mulching and top soil grading; and the restoration of property such as replacing mailboxes, wood chips, planter boxes, flagstones, etc.

LAB00465-001 06/01/2020

LABORER: Highway, Bridge and Airport Construction

AREA 1: GENESEE, MACOMB, MONROE, OAKLAND, WASHTENAW AND WAYNE COUNTIES

AREA 2: ALLEGAN, BARRY, BAY, BERRIEN, BRANCH, CALHOUN, CASS, CLINTON, EATON, GRATIOT, HILLSDALE, HURON, INGHAM, JACKSON, KALAMAZOO, LAPEER, LENAWEE, LIVINGSTON, MIDLAND, MUSKEGON, SAGINAW, SANILAC, SHIAWASSEE, ST. CLAIR, ST. JOSEPH, TUSCOLA AND VAN BUREN COUNTIES

AREA 3: ALCONA, ALPENA, ANTRIM, ARENAC, BENZIE, CHARLEVOIX, CHEBOYGAN, CLARE, CRAWFORD, EMMET, GLADWIN, GRAND TRAVERSE, IONIA, IOSCO, ISABELLA, KALKASKA, KENT, LAKE, LEELANAU, MANISTEE, MASON, MECOSTA, MISSAUKEE, MONTCALM, MONTMORENCY, NEWAYGO, OCEANA, OGEMAW, OSCEOLA, OSCODA, OTSEGO, OTTAWA, PRESQUE ISLE, ROSCOMMON AND WEXFORD COUNTIES

AREA 4: ALGER, BARAGA, CHIPPEWA, DELTA, DICKINSON, GOGEBIC, HOUGHTON, IRON, KEWEENAW, LUCE, MACKINAC, MARQUETTE, MENOMINEE, ONTONAGON AND SCHOOLCRAFT COUNTIES

| | Rates | Fringes |
|------------------|----------|---------|
| LABORER (AREA 1) | | |
| GROUP 1..... | \$ 26.22 | 12.90 |
| GROUP 2..... | \$ 26.43 | 12.90 |
| GROUP 3..... | \$ 26.72 | 12.90 |
| GROUP 4..... | \$ 27.16 | 12.90 |
| GROUP 5..... | \$ 26.78 | 12.90 |
| GROUP 6..... | \$ 27.21 | 12.90 |
| LABORER (AREA 2) | | |
| GROUP 1..... | \$ 26.92 | 12.90 |
| GROUP 2..... | \$ 27.12 | 12.90 |
| GROUP 3..... | \$ 27.36 | 12.90 |
| GROUP 4..... | \$ 27.71 | 12.90 |
| GROUP 5..... | \$ 27.58 | 12.90 |
| GROUP 6..... | \$ 27.92 | 12.90 |
| LABORER (AREA 3) | | |
| GROUP 1..... | \$ 26.22 | 12.90 |
| GROUP 2..... | \$ 26.43 | 12.90 |
| GROUP 3..... | \$ 26.72 | 12.90 |
| GROUP 4..... | \$ 27.16 | 12.90 |
| GROUP 5..... | \$ 26.78 | 12.90 |
| GROUP 6..... | \$ 27.21 | 12.90 |
| LABORER (AREA 4) | | |
| GROUP 1..... | \$ 26.22 | 12.90 |
| GROUP 2..... | \$ 26.43 | 12.90 |
| GROUP 3..... | \$ 26.72 | 12.90 |
| GROUP 4..... | \$ 27.16 | 12.90 |

| | | |
|--------------|----------|-------|
| GROUP 5..... | \$ 26.78 | 12.90 |
| GROUP 6..... | \$ 27.21 | 12.90 |

LABORER CLASSIFICATIONS

GROUP 1: Asphalt shoveler or loader; asphalt plant misc.; burlap person; yard person; dumper (wagon, truck, etc.); joint filling laborer; miscellaneous laborer; unskilled laborer; sprinkler laborer; form setting laborer; form stripper; pavement reinforcing; handling and placing (e.g., wire mesh, steel mats, dowel bars); mason's tender or bricklayer's tender on manholes; manhole builder; headwalls, etc.; waterproofing, (other than buildings) seal coating and slurry mix, shoring, underpinning; pressure grouting; bridge pin and hanger removal; material recycling laborer; horizontal paver laborer (brick, concrete, clay, stone and asphalt); ground stabilization and modification laborer; grouting; waterblasting; top person; railroad track and trestle laborer; carpenters' tender; guard rail builders' tender; earth retention barrier and wall and M.S.E. wall installer's tender; highway and median installer's tender (including sound, retaining, and crash barriers); fence erector's tender; asphalt raker tender; sign installer; remote control operated equipment.

GROUP 2: Mixer operator (less than 5 sacks); air or electric tool operator (jackhammer, etc.); spreader; boxperson (asphalt, stone, gravel); concrete paddler; power chain saw operator; paving batch truck dumper; tunnel mucker (highway work only); concrete saw (under 40 h.p.) and dry pack machine; roto-mill grounds person.

GROUP 3: Tunnel miner (highway work only); finishers tenders; guard rail builders; highway and median barrier installer; earth retention barrier and wall and M.S.E. wall installer's (including sound, retaining and crash barriers); fence erector; bottom person; powder person; wagon drill and air track operator; diamond and core drills; grade checker; certified welders; curb and side rail setter's tender.

GROUP 4: Asphalt raker

GROUP 5: Pipe layers, oxy-gun

GROUP 6: Line-form setter for curb or pavement; asphalt screed checker/screw man on asphalt paving machines.

LAB01076-005 04/01/2019

MICHIGAN STATEWIDE

| | Rates | Fringes |
|-----------------------------|----------|---------|
| LABORER (DISTRIBUTION WORK) | | |
| Zone 1..... | \$ 21.47 | 12.90 |
| Zone 2..... | \$ 19.77 | 12.90 |
| Zone 3..... | \$ 17.95 | 12.90 |
| Zone 4..... | \$ 17.32 | 12.90 |
| Zone 5..... | \$ 17.30 | 12.90 |

DISTRIBUTION WORK - The construction, installation, treating and reconditioning of distribution pipelines transporting coal, oil, gas or other similar materials, vapors or

liquids, including pipelines within private property boundaries, up to and including the meter settings on residential, commercial, industrial, institutional, private and public structures. All work covering pumping stations and tank farms not covered by the Building Trades Agreement. Other distribution lines with the exception of sewer, water and cable television are included.

Underground Duct Layer Pay: \$.40 per hour above the base pay rate.

Zone 1 - Macomb, Oakland and Wayne

Zone 2 - Monroe and Washtenaw

Zone 3 - Bay, Genesee, Lapeer, Midland, Saginaw, Sanilac, Shiawassee and St. Clair

Zone 4 - Alger, Baraga, Chippewa, Delta, Dickinson, Gogebic, Houghton, Iron, Keweenaw, Luce, Mackinac, Marquette, Menominee, Ontonagon and Schoolcraft

Zone 5 - Remaining Counties in Michigan

 PAIN0022-002 07/01/2008

HILLSDALE, JACKSON AND LENAWEE COUNTIES; LIVINGSTON COUNTY (east of the eastern city limits of Howell, not including the city of Howell, north to the Genesee County line and south to the Washtenaw County line); MACOMB, MONROE, OAKLAND, WASHTENAW AND WAYNE COUNTIES:

| | Rates | Fringes |
|--------------|----------|---------|
| PAINTER..... | \$ 25.06 | 14.75 |

FOOTNOTES: For all spray work and journeyman rigging for spray work, also blowing off, \$0.80 per hour additional (applies only to workers doing rigging for spray work on off the floor work. Does not include setting up or moving rigging on floor surfaces, nor does it apply to workers engaged in covering up or tending spray equipment. For all sandblasting and spray work performed on highway bridges, overpasses, tanks or steel, \$0.80 per hour additional. For all brushing, cleaning and other preparatory work (other than spraying or steeplejack work) at scaffold heights of fifty (50) feet from the ground or higher, \$0.50 per hour additional. For all preparatorial work and painting performed on open steel under forty (40) feet when no scaffolding is involved, \$0.50 per hour additional. For all swing stage work-window jacks and window belts-exterior and interior, \$0.50 per hour additional. For all spray work and sandblaster work to a scaffold height of forty (40) feet above the floor level, \$0.80 per hour additional. For all preparatorial work and painting on all highway bridges or overpasses up to forty (40) feet in height, \$0.50 per hour additional. For all steeplejack work performed where the elevation is forty (40) feet or more, \$1.25 per hour additional.

 PAIN0312-001 06/01/2018

EXCLUDES: ALLEGAN COUNTY (Townships of Dorr, Fillmore, Heath, Hopkins, Laketown, Leighton, Manlius, Monterey, Overisel, Salem, Saugatuck and Wayland); INCLUDES: Barry, Berrien, Branch, Calhoun, Cass, Hillsdale, Kalamazoo, St. Joseph, Van

Buren

| | Rates | Fringes |
|------------------------|----------|---------|
| PAINTER | | |
| Brush and roller..... | \$ 23.74 | 13.35 |
| Spray, Sandblast, Sign | | |
| Painting..... | \$ 24.94 | 13.35 |

PAIN0845-003 05/10/2018

CLINTON COUNTY; EATON COUNTY (does not include the townships of Bellevue and Olivet); INGHAM COUNTY; IONIA COUNTY (east of Hwy. M 66); LIVINGSTON COUNTY (west of the eastern city limits of Howell, including the city of Howell, north to the Genesee County line and south to the Washtenaw County line); AND SHIAWASSEE COUNTY (Townships of Bennington, Laingsbury and Perry):

| | Rates | Fringes |
|--------------|----------|---------|
| PAINTER..... | \$ 25.49 | 13.74 |

PAIN0845-015 05/10/2018

MUSKEGON COUNTY; NEWAYGO COUNTY (except the Townships of Barton, Big Prairie, Brooks, Croton, Ensley, Everett, Goodwell, Grant, Home, Monroe, Norwich and Wilcox); OCEANA COUNTY; OTTAWA COUNTY (except the townships of Allendale, Blendone, Chester, Georgetown, Holland, Jamestown, Olive, Park, Polkton, Port Sheldon, Tallmadge, Wright and Zeeland):

| | Rates | Fringes |
|--------------|----------|---------|
| PAINTER..... | \$ 25.49 | 13.74 |

PAIN0845-018 05/10/2018

ALLEGAN COUNTY (Townships of Dorr, Fillmore, Heath, Hopkins, Laketown, Leighton, Manlius, Monterey, Overisel, Salem, Saugatuck and Wayland); IONIA COUNTY (west of Hwy. M-66); KENT, MECOSTA AND MONTCALM COUNTIES; NEWAYGO COUNTY (Townships of Barton, Big Prairie, Brooks, Croton, Ensley, Everett, Goodwell, Grant, Home, Monroe, Norwich and Wilcox); OSCEOLA COUNTY (south of Hwy. #10); OTTAWA COUNTY (Townships of Allendale, Blendone, Chester, Georgetown, Holland, Jamestown, Olive, Park, Polkton, Port Sheldon, Tallmadge, Wright and Zeeland):

| | Rates | Fringes |
|--------------|----------|---------|
| PAINTER..... | \$ 25.49 | 13.74 |

FOOTNOTES: Lead abatement work: \$1.00 per hour additional.

PAIN1011-003 06/02/2019

ALGER, BARAGA, CHIPPEWA, DELTA, DICKINSON, GOGEBIC, HOUGHTON, IRON, KEWEENAW, LUCE, MACKINAC, MARQUETTE, MENOMINEE, ONTONAGON AND SCHOOLCRAFT COUNTIES:

| | Rates | Fringes |
|--------------|----------|---------|
| PAINTER..... | \$ 25.76 | 13.33 |

FOOTNOTES: High pay (bridges, overpasses, watertower): 30 to 80 ft.: \$.65 per hour additional. 80 ft. and over: \$1.30 per hour additional.

PAIN1474-002 06/01/2010

HURON COUNTY; LAPEER COUNTY (east of Hwy. M-53); ST. CLAIR, SANILAC AND TUSCOLA COUNTIES:

| | Rates | Fringes |
|--------------|----------|---------|
| PAINTER..... | \$ 23.79 | 12.02 |

FOOTNOTES: Lead abatement work: \$1.00 per hour additional. Work with any hazardous material: \$1.00 per hour additional. Sandblasting, steam cleaning and acid cleaning: \$1.00 per hour additional. Ladder work at or above 40 ft., scaffold work at or above 40 ft., swing stage, boatswain chair, window jacks and all work performed over a falling height of 40 ft.: \$1.00 per hour additional. Spray gun work, pick pullers and those handling needles, blowing off by air pressure, and any person rigging (setting up and moving off the ground): \$1.00 per hour additional. Steeplejack, tanks, gas holders, stacks, flag poles, radio towers and beacons, power line towers, bridges, etc.: \$1.00 per hour additional, paid from the ground up.

PAIN1803-003 06/01/2019

ALCONA, ALPENA, ANTRIM, ARENAC, BAY, BENZIE, CHARLEVOIX, CHEBOYGAN, CLARE, CRAWFORD, EMMET, GLADWIN, GRAND TRAVERSE, GRATIOT, IOSCO, ISABELLA, KALKASKA, LAKE, LEELANAU, MANISTEE, MASON, MIDLAND, MISSAUKEE, MONTMORENCY AND OGEMAW COUNTIES; OSCEOLA COUNTY (north of Hwy. #10); OSCODA, OTSEGO, PRESQUE ISLE, ROSCOMMON, SAGINAW AND WEXFORD COUNTIES:

| | Rates | Fringes |
|--|----------|---------|
| PAINTER | | |
| Work performed on water, bridges over water or moving traffic, radio and powerline towers, elevated tanks, steeples, smoke stacks over 40 ft. of falling heights, recovery of lead-based paints and any work associated with industrial plants, except maintenance of industrial plants..... | \$ 25.39 | 14.68 |
| All other work, including maintenance of industrial plant..... | \$ 25.39 | 14.68 |

FOOTNOTES: Spray painting, sandblasting, blowdown associated

with spraying and blasting, water blasting and work involving a swing stage, boatswain chair or spider: \$1.00 per hour additional. All work performed inside tanks, vessels, tank trailers, railroad cars, sewers, smoke stacks, boilers or other spaces having limited egress not including buildings, opentop tanks, pits, etc.: \$1.25 per hour additional.

 PLAS0514-001 06/01/2018

ZONE 1: GENESEE, LIVINGSTON, MACOMB, MONROE, OAKLAND, SAGINAW, WASHTENAW AND WAYNE COUNTIES

ZONE 2: ALCONA, ALGER, ALLEGAN, ALPENA, ANTRIM, ARENAC, BARAGA, BARRY, BAY, BENZIE, BERRIEN, BRANCH, CALHOUN, CASS, CHARLEVOIX, CHEBOYGAN, CHIPPEWA, CLARE, CLINTON, CRAWFORD, DELTA, DICKINSON, EATON, EMMET, GLADWIN, GOGEBIC, GRAND TRAVERSE, GRATIOT, HILLSDALE, HOUGHTON, HURON, INGHAM, IONIA, IOSCO, IRON, ISABELLA, JACKSON, KALAMAZOO, KALKASKA, KENT, KEWEENAW, LAKE, LAPEER, LEELANAU, LENAWEE, LUCE, MACKINAC, MANISTEE, MARQUETTE, MASON, MECOSTA, MENOMINEE, MIDLAND, MISSAUKEE, MONTCALM, MONTMORENCY, MUSKEGON, NEWAYGO, OCEANA, OGEMAW, ONTONAGON, OSCEOLA, OSCODA, OTSEGO, OTTAWA, PRESQUE ISLE, ROSCOMMON, SANILAC, SCHOOLCRAFT, SHIAWASSEE, ST. CLAIR, ST. JOSEPH, TUSCOLA, VAN BUREN AND WEXFORD COUNTIES

| | Rates | Fringes |
|--------------------------------|----------|---------|
| CEMENT MASON/CONCRETE FINISHER | | |
| ZONE 1..... | \$ 31.47 | 13.81 |
| ZONE 2..... | \$ 29.97 | 13.81 |

 PLUM0190-003 05/01/2015

ALCONA, ALGER, ALLEGAN, ALPENA, ANTRIM, ARENAC, BARAGA, BARRY, BAY, BENZIE, BERRIEN, BRANCH, CALHOUN, CASS, CHARLEVOIX, CHEBOYGAN, CHIPPEWA, CLARE, CLINTON, CRAWFORD, DELTA, DICKINSON, EATON, EMMET, GENESEE, GLADWIN, GOGEBIC, GRAND TRAVERSE, GRATIOT, HILLSDALE, HOUGHTON, HURON, INGHAM, IONIA, IOSCO, IRON, ISABELLA, JACKSON, KALAMAZOO, KALKASKA, KENT, KEWEENAW, LAKE, LAPEER, LEELANAU, LENAWEE, LIVINGSTON, LUCE, MACKINAC, MACOMB, MANISTEE, MARQUETTE, MASON, MECOSTA, MENOMINEE, MIDLAND, MISSAUKEE, MONTCALM, MONTMORENCY, MONROE, MUSKEGON, NEWAYGO, OAKLAND, OCEANA, OGEMAW, ONTONAGON, OSCEOLA, OSCODA, OTSEGO, OTTAWA, PRESQUE ISLE, ROSCOMMON, SAGINAW, ST. CLARE, ST. JOSEPH, SANILAC, SCHOOLCRAFT, SHIAWASSEE, TUSCOLA, VAN BUREN, WASHTENAW, WAYNE AND WEXFORD COUNTIES

| | Rates | Fringes |
|--------------------------|----------|---------|
| Plumber/Pipefitter - gas | | |
| distribution pipeline: | | |
| Welding in conjunction | | |
| with gas distribution | | |
| pipeline work..... | \$ 33.03 | 20.19 |
| All other work:..... | \$ 24.19 | 12.28 |

 TEAM0007-004 06/01/2020

AREA 1: ALCONA, ALGER, ALLEGAN, ALPENA, ANTRIM, ARENAC, BARAGA, BARRY, BAY, BENZIE, BERRIEN, BRANCH, CALHOUN, CASS, CHARLEVOIX, CHEBOYGAN, CHIPPEWA, CLARE, CLINTON, CRAWFORD, DELTA,

DICKINSON, EATON, EMMET, GLADWIN, GOGEBIC, GRAND TRAVERSE, GRATIOT, HILLSDALE, HOUGHTON, HURON, INGHAM, IONIA, IOSCO, IRON, ISABELLA, JACKSON, KALAMAZOO, KALKASKA, KENT, KEWEENAW, LAKE, LAPEER, LEELANAU, LENAWEE, LUCE, MACKINAC, MANISTEE, MARQUETTE, MASON, MECOSTA, MENOMINEE, MIDLAND, MISSAUKEE, MONTCALM, MONTMORENCY, MUSKEGON, NEWAYGO, OCEANA, OGEMAW, ONTONAGON, OSCEOLA, OSCODA, OTSEGO, OTTAWA, PRESQUE ISLE, ROSCOMMON, SAGINAW, SANILAC, SCHOOLCRAFT, SHIAWASSEE, ST. CLAIR, ST. JOSEPH, TUSCOLA, VAN BUREN AND WEXFORD COUNTIES

AREA 2: GENESEE, LIVINGSTON, MACOMB, MONROE, OAKLAND, WASHTENAW AND WAYNE COUNTIES

| | Rates | Fringes |
|-----------------------------|-----------|-----------|
| TRUCK DRIVER | | |
| AREA 1 | | |
| Euclids, double bottoms | | |
| and lowboys..... | \$ 28.05 | .50 + a+b |
| Trucks under 8 cu. yds..... | \$ 27.80 | .50 + a+b |
| Trucks, 8 cu. yds. and | | |
| over..... | \$ 27.90 | .50 + a+b |
| AREA 2 | | |
| Euclids, double bottomms | | |
| and lowboys..... | \$ 24.895 | .50 + a+b |
| Euclids, double bottoms | | |
| and lowboys..... | \$ 28.15 | .50 + a+b |
| Trucks under 8 cu. yds..... | \$ 27.90 | .50 + a+b |
| Trucks, 8 cu. yds. and | | |
| over..... | \$ 28.00 | .50 + a+b |

Footnote:

- a. \$47.70 per week
- b. \$68.70 daily

 TEAM0247-004 04/01/2013

AREA 1: ALCONA, ALGER, ALLEGAN, ALPENA, ANTRIM, ARENAC, BARAGA, BARRY, BAY, BENZIE, BERRIEN, BRANCH, CALHOUN, CASS, CHARLEVOIX, CHEBOYGAN, CHIPPEWA, CLARE, CLINTON, CRAWFORD, DELTA, DICKINSON, EATON, EMMET, GLADWIN, GOGEBIC, GRAND TRAVERSE, GRATIOT, HILLSDALE, HOUGHTON, HURON, INGHAM, IONIA, IOSCO, IRON, ISABELLA, JACKSON, KALAMAZOO, KALKASKA, KENT, KEWEENAW, LAKE, LAPEER, LEELANAU, LENAWEE, LUCE, MACKINAC, MANISTEE, MARQUETTE, MASON, MECOSTA, MENOMINEE, MIDLAND, MISSAUKEE, MONTCALM, MONTMORENCY, MUSKEGON, NEWAYGO, OCEANA, OGEMAW, ONTONAGON, OSCEOLA, OSCODA, OTSEGO, OTTAWA, PRESQUE ISLE, ROSCOMMON, SANILAC, SCHOOLCRAFT, SHIAWASSEE, SAGINAW, ST. CLAIR, ST. JOSEPH, TUSCOLA, VAN BUREN AND WEXFORD COUNTIES

AREA 2: GENESEE, LIVINGSTON, MACOMB, MONROE, OAKLAND, WASHTENAW AND WAYNE COUNTIES

| | Rates | Fringes |
|----------------|----------|---------|
| Sign Installer | | |
| AREA 1 | | |
| GROUP 1..... | \$ 21.78 | 11.83 |
| GROUP 2..... | \$ 25.27 | 11.8375 |
| AREA 2 | | |
| GROUP 1..... | \$ 22.03 | 11.83 |
| GROUP 2..... | \$ 25.02 | 11.8375 |

FOOTNOTE:

a. \$132.70 per week, plus \$17.80 per day.

SIGN INSTALLER CLASSIFICATIONS:

GROUP 1: performs all necessary labor and uses all tools required to construct and set concrete forms required in the installation of highway and street signs

GROUP 2: performs all miscellaneous labor, uses all hand and power tools, and operates all other equipment, mobile or otherwise, required for the installation of highway and street signs

TEAM0247-010 04/01/2018

AREA 1: LAPEER AND SHIAWASSEE COUNTIES

AREA 2: GENESEE, MACOMB, MONROE, OAKLAND, ST. CLAIR, WASHTENAW AND WAYNE COUNTIES

| | Rates | Fringes |
|---|----------|---------|
| TRUCK DRIVER (Underground construction) | | |
| AREA 1 | | |
| GROUP 1..... | \$ 23.82 | 19.04 |
| GROUP 2..... | \$ 23.91 | 19.04 |
| GROUP 3..... | \$ 24.12 | 19.04 |
| AREA 2 | | |
| GROUP 1..... | \$ 24.12 | 19.04 |
| GROUP 2..... | \$ 24.26 | 19.04 |
| GROUP 3..... | \$ 24.45 | 19.04 |

PAID HOLIDAYS: New Year's Day, Memorial Day, Fourth of July, Labor Day, Thanksgiving Day and Christmas Day.

SCOPE OF WORK: Excavation, site preparation, land balancing, grading, sewers, utilities and improvements; also including but not limited to, tunnels, underground piping, retention, oxidation, flocculation facilities, conduits, general excavation and steel sheeting for underground construction. Underground construction work shall not include any structural modifications, alterations, additions and repairs to buildings or highway work, including roads, streets, bridge construction and parking lots or steel erection.

TRUCK DRIVER CLASSIFICATIONS

GROUP 1: Truck driver on all trucks (EXCEPT dump trucks of 8 cubic yards capacity or over, pole trailers, semis, low boys, Euclid, double bottom and fuel trucks)

GROUP 2: Truck driver on dump trucks of 8 cubic yards capacity or over, pole trailers, semis and fuel trucks

GROUP 3: Truck driver on low boy, Euclid and double bottom

SUMI2002-001 05/01/2002

| | Rates | Fringes |
|--|----------|---------|
| Flag Person..... | \$ 10.10 | 0.00 |
| LINE PROTECTOR (ZONE 1: GENESEE, MACOMB, MONROE, OAKLAND, WASHTENAW AND WAYNE).... | \$ 20.30 | 12.90 |
| LINE PROTECTOR (ZONE 2: STATEWIDE (EXCLUDING GENESEE, MACOMB, MONROE, OAKLAND, WASHTENAW AND WAYNE)..... | \$ 18.02 | 12.90 |
| Pavement Marking Machine (ZONE 1: GENESEE, MACOMB, MONROE, OAKLAND, WASHTENAW AND WAYNE COUNTIES) Group 1..... | \$ 27.07 | 12.90 |
| Pavement Marking Machine (ZONE 1: GENESEE, MACOMB, MONROE, OAKLAND, WASHTENAW AND WAYNE) Group 2..... | \$ 24.36 | 12.90 |
| Pavement Marking Machine (ZONE 2: STATEWIDE (EXCLUDING GENESEE, MACOMB, MONROE, OAKLAND, WASHTENAW AND WAYNE COUNTIES) Group 1..... | \$ 24.02 | 12.90 |
| Pavement Marking Machine (ZONE 2: STATEWIDE (EXCLUDING GENESEE, MACOMB, MONROE, OAKLAND, WASHTENAW AND WAYNE) Group 2..... | \$ 21.62 | 12.90 |

WORK CLASSIFICATIONS:

PAVEMENT MARKER GROUP 1: Drives or operates a truck mounted striper, grinder, blaster, groover, or thermoplastic melter for the placement or removal of temporary or permanent pavement markings or markers.

PAVEMENT MARKER GROUP 2: Performs all functions involved for the placement or removal of temporary or permanent pavement markings or markers not covered by the classification of Pavement Marker Group 1 or Line Protector.

LINE PROTECTOR: Performs all operations for the protection or removal of temporary or permanent pavement markings or markers in a moving convoy operation not performed by the classification of Pavement Marker Group 1. A moving convoy operation is comprised of only Pavement Markers Group 1 and Line Protectors.

WELDERS - Receive rate prescribed for craft performing operation to which welding is incidental.

=====

Note: Executive Order (EO) 13706, Establishing Paid Sick Leave for Federal Contractors applies to all contracts subject to the Davis-Bacon Act for which the contract is awarded (and any solicitation was issued) on or after January 1, 2017. If this contract is covered by the EO, the contractor must provide employees with 1 hour of paid sick leave for every 30 hours they work, up to 56 hours of paid sick leave each year. Employees must be permitted to use paid sick leave for their own illness, injury or other health-related needs, including preventive care; to assist a family member (or person who is like family to the employee) who is ill, injured, or has other health-related needs, including preventive care; or for reasons resulting from, or to assist a family member (or person who is like family to the employee) who is a victim of, domestic violence, sexual assault, or stalking. Additional information on contractor requirements and worker protections under the EO is available at www.dol.gov/whd/govcontracts.

Unlisted classifications needed for work not included within the scope of the classifications listed may be added after award only as provided in the labor standards contract clauses (29CFR 5.5 (a) (1) (ii)).

The body of each wage determination lists the classification and wage rates that have been found to be prevailing for the cited type(s) of construction in the area covered by the wage determination. The classifications are listed in alphabetical order of "identifiers" that indicate whether the particular rate is a union rate (current union negotiated rate for local), a survey rate (weighted average rate) or a union average rate (weighted union average rate).

Union Rate Identifiers

A four letter classification abbreviation identifier enclosed in dotted lines beginning with characters other than "SU" or "UAVG" denotes that the union classification and rate were prevailing for that classification in the survey. Example: PLUM0198-005 07/01/2014. PLUM is an abbreviation identifier of the union which prevailed in the survey for this classification, which in this example would be Plumbers. 0198 indicates the local union number or district council number where applicable, i.e., Plumbers Local 0198. The next number, 005 in the example, is an internal number used in processing the wage determination. 07/01/2014 is the effective date of the most current negotiated rate, which in this example is July 1, 2014.

Union prevailing wage rates are updated to reflect all rate changes in the collective bargaining agreement (CBA) governing this classification and rate.

Survey Rate Identifiers

Classifications listed under the "SU" identifier indicate that no one rate prevailed for this classification in the survey and the published rate is derived by computing a weighted average rate based on all the rates reported in the survey for that classification. As this weighted average rate includes all rates reported in the survey, it may include both union and non-union rates. Example: SULA2012-007 5/13/2014. SU indicates

the rates are survey rates based on a weighted average calculation of rates and are not majority rates. LA indicates the State of Louisiana. 2012 is the year of survey on which these classifications and rates are based. The next number, 007 in the example, is an internal number used in producing the wage determination. 5/13/2014 indicates the survey completion date for the classifications and rates under that identifier.

Survey wage rates are not updated and remain in effect until a new survey is conducted.

Union Average Rate Identifiers

Classification(s) listed under the UAVG identifier indicate that no single majority rate prevailed for those classifications; however, 100% of the data reported for the classifications was union data. EXAMPLE: UAVG-OH-0010 08/29/2014. UAVG indicates that the rate is a weighted union average rate. OH indicates the state. The next number, 0010 in the example, is an internal number used in producing the wage determination. 08/29/2014 indicates the survey completion date for the classifications and rates under that identifier.

A UAVG rate will be updated once a year, usually in January of each year, to reflect a weighted average of the current negotiated/CBA rate of the union locals from which the rate is based.

WAGE DETERMINATION APPEALS PROCESS

1.) Has there been an initial decision in the matter? This can be:

- * an existing published wage determination
- * a survey underlying a wage determination
- * a Wage and Hour Division letter setting forth a position on a wage determination matter
- * a conformance (additional classification and rate) ruling

On survey related matters, initial contact, including requests for summaries of surveys, should be with the Wage and Hour Regional Office for the area in which the survey was conducted because those Regional Offices have responsibility for the Davis-Bacon survey program. If the response from this initial contact is not satisfactory, then the process described in 2.) and 3.) should be followed.

With regard to any other matter not yet ripe for the formal process described here, initial contact should be with the Branch of Construction Wage Determinations. Write to:

Branch of Construction Wage Determinations
Wage and Hour Division
U.S. Department of Labor
200 Constitution Avenue, N.W.
Washington, DC 20210

2.) If the answer to the question in 1.) is yes, then an interested party (those affected by the action) can request review and reconsideration from the Wage and Hour Administrator (See 29 CFR Part 1.8 and 29 CFR Part 7). Write to:

Wage and Hour Administrator
U.S. Department of Labor
200 Constitution Avenue, N.W.
Washington, DC 20210

The request should be accompanied by a full statement of the interested party's position and by any information (wage payment data, project description, area practice material, etc.) that the requestor considers relevant to the issue.

3.) If the decision of the Administrator is not favorable, an interested party may appeal directly to the Administrative Review Board (formerly the Wage Appeals Board). Write to:

Administrative Review Board
U.S. Department of Labor
200 Constitution Avenue, N.W.
Washington, DC 20210

4.) All decisions by the Administrative Review Board are final.

=====

END OF GENERAL DECISION"

#9

RESOLUTION



CITY OF PONTIAC

OFFICIAL MEMORANDUM

Executive Branch

TO: Honorable Mayor, Council President and City Council Members

FROM: Abdul H. Siddiqui, City Engineer

DATE: July 13, 2021

RE: Vanguard Drive Reconstruction Project – Mark Anthony Contracting, Inc.

The City of Pontiac received and publicly opened bids for the referenced improvement project on Thursday, June 24, 2021. The project is the reconstruction of the deteriorated concrete pavement on Vanguard Drive from Telegraph to approximately 637 ft east.

A total of three (3) bids were received for the project in the amounts as follows:

1. Mark Anthony Contracting, Inc. \$617,118.69
2. Angelo Iafrate Construction Co. \$644,076.00
3. Merlo Construction Co. \$660,755.25

The Engineering Division has reviewed the proposals and references submitted by all contractors and based on the attached is recommending the award to the low bidder, Mark Anthony Contracting, Inc.

Construction is scheduled to start in early August with anticipated completion within ninety (90) days.

Funding for the project is identified in FY 21-22 Major Street Fund.

Based upon the above information, it is recommendation of the Department of Public Works that the Vanguard Drive Reconstruction Project be awarded to Mark Anthony Contracting, Inc., in the amount of \$617,118.69.

WHEREAS, the City of Pontiac has advertised and received responses to a Request For Proposal for the Vanguard Drive Reconstruction Project on June 24, 2021, and publically opened bids; and

WHEREAS, a bid tabulation was prepared and reviewed, and;

WHEREAS, the City identified the low bidder as Mark Anthony Contracting, Inc., and references of the low bidder checked and found acceptable.

NOW, THEREFORE,
BE IT RESOLVED, The Pontiac City Council authorizes the Mayor to enter into a contract with Mark Anthony Contracting, Inc. for \$617,118.69 for the Vanguard Drive Reconstruction Project.

City of Pontiac
 Bid Tabulation
 Vanguard Road CCP Project (Telegraph Rd to 637' East)
 6/25/2021

| LN | DESCRIPTION | EST. QTY. | Engineer's Estimate Hubbell, Roth & Clark, Inc. | | Mark Anthony Contracting Inc. Milford, MI bond?- Yes | | Angelo Iafrate Construction Co. Warren, MI bond?- Yes | | Merlo Construction Co. Milford, MI bond?-Yes | |
|----|--|-----------|--|--------------|--|--------------|---|--------------|--|--------------|
| | | | Unit Price | Extended | Unit Price | Extended | Unit Price | Extended | Unit Price | Extended |
| | Itemized Bid | | | | | | | | | |
| 1 | Mobilization, Max. 10% | 1 | \$44,400.00 | \$44,400.00 | \$50,626.01 | \$50,626.01 | \$60,000.00 | \$60,000.00 | \$60,000.00 | \$60,000.00 |
| 2 | Pavt, Rem | 4776 | \$10.00 | \$47,760.00 | \$13.80 | \$65,908.80 | \$5.00 | \$23,880.00 | \$20.00 | \$95,520.00 |
| 3 | Exploratory Investigation, Vertical | 25 | \$100.00 | \$2,500.00 | \$101.39 | \$2,534.75 | \$50.00 | \$1,250.00 | \$1.00 | \$25.00 |
| 4 | Embankment, CIP | 455 | \$12.00 | \$5,460.00 | \$17.22 | \$7,835.10 | \$10.00 | \$4,550.00 | \$10.00 | \$4,550.00 |
| 5 | Excavation, Earth | 1078 | \$10.00 | \$10,780.00 | \$22.67 | \$24,438.26 | \$25.00 | \$26,950.00 | \$19.00 | \$20,482.00 |
| 6 | Erosion Control, Inlet Protection, Fabric Drop | 9 | \$100.00 | \$900.00 | \$71.57 | \$644.13 | \$100.00 | \$900.00 | \$150.00 | \$1,350.00 |
| 7 | Project Cleanup, Special | 1 | \$821.40 | \$821.40 | \$5,166.02 | \$5,166.02 | \$1,500.00 | \$1,500.00 | \$1,000.00 | \$1,000.00 |
| 8 | Aggregate Base, 8 inch | 4650 | \$12.00 | \$55,800.00 | \$12.26 | \$57,009.00 | \$15.00 | \$69,750.00 | \$17.00 | \$79,050.00 |
| 9 | Aggregate Base, Conditioning | 3793 | \$2.50 | \$9,482.50 | \$1.41 | \$5,348.13 | \$1.00 | \$3,793.00 | \$1.25 | \$4,741.25 |
| 10 | Maintenance Gravel | 72 | \$25.00 | \$1,800.00 | \$25.05 | \$1,803.60 | \$40.00 | \$2,880.00 | \$17.00 | \$1,224.00 |
| 11 | Sewer Tap, 12 inch | 1 | \$600.00 | \$600.00 | \$250.49 | \$250.49 | \$1,300.00 | \$1,300.00 | \$400.00 | \$400.00 |
| 12 | Dr Structure Cover, Adj, Case 1 | 5 | \$500.00 | \$2,500.00 | \$178.92 | \$894.60 | \$375.00 | \$1,875.00 | \$600.00 | \$3,000.00 |
| 13 | Dr Structure Cover, Adj, Case 2 | 1 | \$400.00 | \$400.00 | \$178.92 | \$178.92 | \$375.00 | \$375.00 | \$525.00 | \$525.00 |
| 14 | Dr Structure Cover, Type G | 1 | \$600.00 | \$600.00 | \$536.76 | \$536.76 | \$450.00 | \$450.00 | \$600.00 | \$600.00 |
| 15 | Dr Structure Cover, Type K | 6 | \$600.00 | \$3,600.00 | \$596.40 | \$3,578.40 | \$750.00 | \$4,500.00 | \$1,400.00 | \$8,400.00 |
| 16 | Dr Structure, 24 inch dia | 1 | \$1,250.00 | \$1,250.00 | \$1,192.80 | \$1,192.80 | \$3,200.00 | \$3,200.00 | \$2,000.00 | \$2,000.00 |
| 17 | Dr Structure, Adj, Add Depth | 10 | \$200.00 | \$2,000.00 | \$143.14 | \$1,431.40 | \$150.00 | \$1,500.00 | \$125.00 | \$1,250.00 |
| 18 | Underdrain, Subgrade, Open-Graded, 6 inch, Special | 1340 | \$15.00 | \$20,100.00 | \$15.51 | \$20,783.40 | \$25.00 | \$33,500.00 | \$17.00 | \$22,780.00 |
| 19 | HMA Surface, Rem | 24 | \$15.00 | \$360.00 | \$5.96 | \$143.04 | \$10.00 | \$240.00 | \$13.00 | \$312.00 |
| 20 | Hand Patching | 6 | \$150.00 | \$900.00 | \$268.38 | \$1,610.28 | \$150.00 | \$900.00 | \$333.33 | \$2,000.00 |
| 21 | Compacted Conc Pavt, 9 inch | 3793 | \$55.00 | \$208,615.00 | \$69.30 | \$262,854.90 | \$55.00 | \$208,615.00 | \$60.00 | \$227,580.00 |
| 22 | Curb and Gutter, Conc, Det F4 | 2327 | \$20.00 | \$46,540.00 | \$29.82 | \$69,391.14 | \$20.00 | \$46,540.00 | \$24.00 | \$55,848.00 |
| 23 | Driveway Opening, Conc, Det M | 140 | \$20.00 | \$2,800.00 | \$33.40 | \$4,676.00 | \$30.00 | \$4,200.00 | \$32.00 | \$4,480.00 |
| 24 | Barricade, Type III, High Intensity, Double Sided, Lighted, Furn, Modified | 19 | \$100.00 | \$1,900.00 | \$113.32 | \$2,153.08 | \$55.00 | \$1,045.00 | \$150.00 | \$2,850.00 |
| 25 | Barricade, Type III, High Intensity, Double Sided, Lighted, Oper, Modified | 19 | \$5.00 | \$95.00 | \$0.01 | \$0.19 | \$1.00 | \$19.00 | \$1.00 | \$19.00 |
| 26 | Channelizing Device, 42 inch, Fluorescent, Furn, Modified | 108 | \$20.00 | \$2,160.00 | \$33.40 | \$3,607.20 | \$28.00 | \$3,024.00 | \$27.00 | \$2,916.00 |
| 27 | Channelizing Device, 42 inch, Fluorescent, Oper, Modified | 108 | \$1.00 | \$108.00 | \$0.01 | \$1.08 | \$1.00 | \$108.00 | \$1.00 | \$108.00 |
| 28 | Lighted Arrow, Type C, Furn, Modified | 1 | \$750.00 | \$750.00 | \$715.68 | \$715.68 | \$600.00 | \$600.00 | \$1,500.00 | \$1,500.00 |
| 29 | Lighted Arrow, Type C, Oper, Modified | 1 | \$100.00 | \$100.00 | \$0.01 | \$0.01 | \$1.00 | \$1.00 | \$1.00 | \$1.00 |
| 30 | Minor Traf Devices | 1 | \$17,760.00 | \$17,760.00 | \$4,999.02 | \$4,999.02 | \$112,000.00 | \$112,000.00 | \$15,000.00 | \$15,000.00 |
| 31 | Plastic Drum, Fluorescent, Furn, Modified | 45 | \$20.00 | \$900.00 | \$34.59 | \$1,556.55 | \$29.00 | \$1,305.00 | \$27.00 | \$1,215.00 |
| 32 | Plastic Drum, Fluorescent, Oper, Modified | 45 | \$1.00 | \$45.00 | \$0.01 | \$0.45 | \$1.00 | \$45.00 | \$1.00 | \$45.00 |
| 33 | Sign, Type B, Temp, Prismatic, Furn, Modified | 288 | \$6.00 | \$1,728.00 | \$8.35 | \$2,404.80 | \$6.00 | \$1,728.00 | \$2.00 | \$576.00 |
| 34 | Sign, Type B, Temp, Prismatic, Oper, Modified | 288 | \$1.00 | \$288.00 | \$0.01 | \$2.88 | \$1.00 | \$288.00 | \$1.00 | \$288.00 |
| 35 | Traf Regulator Control | 1 | \$22,200.00 | \$22,200.00 | \$1,431.36 | \$1,431.36 | \$5,000.00 | \$5,000.00 | \$10,000.00 | \$10,000.00 |
| 36 | Seeding, Mixture THM | 45 | \$20.00 | \$900.00 | \$5.78 | \$260.10 | \$50.00 | \$2,250.00 | \$40.00 | \$1,800.00 |
| 37 | Fertilizer, Chemical Nutrient, Cl B | 45 | \$8.00 | \$360.00 | \$3.28 | \$147.60 | \$5.00 | \$225.00 | \$20.00 | \$900.00 |
| 38 | Topsoil Surface, Furn, 2 inch | 90 | \$3.50 | \$315.00 | \$8.88 | \$799.20 | \$15.00 | \$1,350.00 | \$30.00 | \$2,700.00 |

City of Pontiac
 Bid Tabulation
 Vanguard Road CCP Project (Telegraph Rd to 637' East)
 6/25/2021

| LN | DESCRIPTION | EST. QTY. | Engineer's Estimate Hubbell, Roth & Clark, Inc. | | Mark Anthony Contracting Inc. Milford, MI bond?- Yes | | Angelo Iafrate Construction Co. Warren, MI bond?- Yes | | Merlo Construction Co. Milford, MI bond?-Yes | |
|----|------------------------------------|-----------|--|---------------|--|---------------|---|---------------|--|---------------|
| | | | Unit Price | Extended | Unit Price | Extended | Unit Price | Extended | Unit Price | Extended |
| | Itemized Bid | | | | | | | | | |
| 39 | Mulch Blanket | 90 | \$2.00 | \$180.00 | \$6.86 | \$617.40 | \$5.00 | \$450.00 | \$18.00 | \$1,620.00 |
| 40 | Water, Sodding/Seeding | 2 | \$95.00 | \$152.00 | \$124.05 | \$198.48 | \$250.00 | \$400.00 | \$2,000.00 | \$3,200.00 |
| 41 | Traf Loop | 4 | \$1,700.00 | \$6,800.00 | \$1,431.36 | \$5,725.44 | \$2,000.00 | \$8,000.00 | \$2,250.00 | \$9,000.00 |
| 42 | TS Head, Temp | 1 | \$1,500.00 | \$1,500.00 | \$1,431.36 | \$1,431.36 | \$1,200.00 | \$1,200.00 | \$1,500.00 | \$1,500.00 |
| 43 | TS Face, Bag | 1 | \$450.00 | \$450.00 | \$298.20 | \$298.20 | \$125.00 | \$125.00 | \$250.00 | \$250.00 |
| 44 | TS Face, Bag, Rem | 1 | \$150.00 | \$150.00 | \$178.92 | \$178.92 | \$125.00 | \$125.00 | \$250.00 | \$250.00 |
| 45 | Sprinkler Line, Modified | 100 | \$4.00 | \$400.00 | \$7.16 | \$716.00 | \$10.00 | \$1,000.00 | \$25.00 | \$2,500.00 |
| 46 | Sprinkler Head, Replace, Modified | 6 | \$80.00 | \$480.00 | \$89.46 | \$536.76 | \$100.00 | \$600.00 | \$450.00 | \$2,700.00 |
| 47 | Sprinkler Head, Relocate, Modified | 6 | \$65.00 | \$390.00 | \$83.50 | \$501.00 | \$90.00 | \$540.00 | \$450.00 | \$2,700.00 |
| | Total Bid | | | \$ 530,079.90 | | \$ 617,118.69 | | \$ 644,076.00 | | \$ 660,755.25 |

Bid notifications were posted on BidNet, HRC Bid List, and MCA weekly news letter. We received three (3) bids for the project.

RED FONT INDICATES CORRECTED TOTAL

SPECIFICATIONS AND CONTRACT DOCUMENTS

FOR

CITY OF PONTIAC

DEPARTMENT OF PUBLIC WORKS
ENGINEERING DIVISION

VANGUARD DRIVE
COMPACTED CONCRETE PROJECT
STARTING AT TELEGRAPH RD TO 637 FEET EAST



BIDS DUE:

Thursday, June 24, 2021
1:00 P.M.

City Clerks Office
Pontiac City Hall
47450 Woodward Avenue
Pontiac, MI 48342

PRE-BID MEETING:

Meeting Details will be issued
by Addendum 1

ENGINEER

HUBELL, ROTH & CLARK, INC.
555 HULET DRIVE
BLOOMFIELD TWP, MI 48302
(248) 454-6300
HRC Job No.20200981

CONTRACT DOCUMENTS
VANGUARD DRIVE

| <u>TABLE OF CONTENTS</u> | <u>PAGE</u> |
|---|--------------------|
| Advertisement | 1 |
| Instructions to Bidder | 3 |
| 1. Proposals to be Received | 3 |
| 2. Location of the Work | 3 |
| 3. Inspection of the Site | 3 |
| 4. Conformity to Plans, Specifications and other Contract Documents | 4 |
| 5. Basis on which Proposals are Solicited | 4-5 |
| 6. Form of Proposals | 6 |
| 7. Legal Status of Bidder | 6 |
| 8. Agency | 6 |
| 9. Bid Deposit | 6,7 |
| 10. INTENTIONALLY LEFT BLANK | 7 |
| 11. Statement of Bidder's Qualifications | 7 |
| 12. Payments | 8 |
| 13. Time of Completion | 8 |
| 14. Right to Accept, to Reject and to Waive Defects | 8 |
| 15. Award of Contract | 8 |
| 16. Obligation to Execute Contract | 8 |
| 17. Bonds | 9 |
| 18. Indemnification and Insurance | 9,10 |
| 19. City Income Tax | 10,11 |
| 20. Pre-Bid Meeting | 11 |
| 21. City of Pontiac - Purchasing Ordinance | 11 |
| Sample Insurance Certificate | 12 |
| Bid Forms | |
| 1. Form of Proposal (<u>6</u> Pages) | 13-16 |
| 2. Participation Plan Form (<u>3</u> Pages) | 17-18a |
| Agreement and Bonds | |
| 1. Bid Bond (Form) (<u>2</u> Pages) | 19,20 |
| 2. Agreement (Form) (<u>4</u> Pages) | 21-24 |
| 3. Bond for Faithful Performance (Form) | 25,26 |
| 4. Labor and Materials Bond to the City of Pontiac, Michigan (Form) | 27,28 |
| 5. Maintenance Bond (Form) | 29,30 |

TABLE OF CONTENTS (Continued)**PAGE**

| | |
|---|-------|
| General Conditions | 31-51 |
| 1. Definitions | 32-34 |
| 2. Plans and Specifications | 34-35 |
| 3. Shop Drawings | 35 |
| 4. Materials and Workmanship | 36 |
| 5. Superintendence by Contractor | 37-38 |
| 6. Engineering Supervision | 38-39 |
| 7. City's Right to Complete; Suspension or Termination | 39 |
| 8. Assignment of Contract | 39-40 |
| 9. Extra Work and Modification | 40-41 |
| 10. Disputed Claims for Extra Compensation | 41 |
| 11. Extension of Time | 41-42 |
| 12. Liquidated Damages | 42 |
| 13. Payments to the Contractor | 42-44 |
| 14. Warranty Maintenance | 44 |
| 15. Michigan Non-Discrimination Statute | 44-45 |
| 16. Labor Laws and Ordinances; Affirmative Action | 45 |
| 17. Patents, Patent Rights and Trademarks | 45 |
| 18. Work within Railroad, Private, State or County Right-of-Way | 45 |
| 19. Protection and Safety | 45-49 |
| 20. Cleaning Up | 49 |
| 21. Progress Schedule | 49 |
| 22. Contractor's Declaration | 50 |
| 23. Contractor's Affidavit | 51 |
| Notices to Bidders, Specifications and Special Provisions | 52-96 |
| 1. Table of Content | 52 |
| 2. MDOT Specification Reference | 53 |
| 3. Progress Clause | 54-56 |
| 4. Utility Coordination | 57-59 |
| 5. Project Coordination | 60 |
| 6. Permits and Inspection Fees | 61-62 |
| 7. Maintaining Traffic | 63-73 |
| 8. Pavement Cores | 74-80 |
| 9. Project Cleanup | 81 |
| 10. Geotextile Fabric | 82-83 |
| 11. Underdrains | 84 |
| 12. Compacted Concrete Pavement | 85-93 |
| 13. Temp. Construction Work Zone Signs and Barricades | 94 |
| 14. Reconstructing Sprinkler Systems | 95-96 |

**CITY OF PONTIAC
ADVERTISEMENT FOR BIDS**

Notice to Contractors

Sealed proposals will be received at the office of the City Clerk, City Hall, 47450 Woodward Avenue, Pontiac, Michigan 48342, until **1:00 p.m., EDT, 24, June 2021**, at which time the bids will be publicly opened and read by the Clerk and the amounts of the bids noted for the:

Vanguard Drive Compacted Concrete Project

Project Description

This project is being bid for the removal and replacement of the concrete pavement along Vanguard Drive starting at the edge of Telegraph Road to 637 feet east. The project includes 4,776 square yards of pavement removal, 4,650 square yards of 8-inch aggregate base, 2,327 feet of curb and gutter, and 3,793 square yard of 9-inch compacted concrete pavement.

The plans and specification documents will be available on or after 12:00 Noon on Tuesday, June 1st 2021 at the office of Hubbell, Roth & Clark, Inc., at 555 Hulet Drive, Bloomfield Hills, MI 48302. Please contact the office of Hubbell, Roth & Clark, Inc. by phone or email at 248-454-6300, or frontdesk@hrcenr.com to obtain the Procurement Documents. A non-refundable payment of sixty (\$60.00) Dollars is required by CHECK or CREDIT CARD ONLY. Check can be made payable to "Hubbell, Roth & Clark, Inc.", and may be mailed to the office or accepted in person. Procurement Documents will be a set of both electronically and hard copy upon confirmation of payment. Drawings and Specifications can be shipped by U.P.S. ground for an additional shipping and handling charge of Twenty (\$20.00) Dollars. *The Bidder is advised that to submit a bid on this project, the Bidder must have purchased a set of Drawings and Specifications from Hubbell, Roth & Clark, Inc.*

A mandatory pre-bid meeting will be scheduled through **Addendum 1** which will be emailed to every bidder. Contract requirements and technical specifications will be discussed in said meeting and it is mandatory that all prospective bidders attend.

A certified check or a satisfactory surety bid bond for a sum not less than five (5) percent of the amount of the proposal will be required with each proposal as a guarantee of good faith and same to be subject to the conditions stipulated in the Instructions to Bidders.

The bidder will be required to comply with Michigan statutory prohibitions against discrimination in employment.

No proposal once submitted may be withdrawn for at least 90 days after the actual opening of the bids.

The right to accept any proposal, to reject any or all proposals, and to waive defects in proposals, is reserved by the City.

BY THE ORDER OF:

**DIERDRE WATERMAN, MAYOR
CITY OF PONTIAC**

**DAN RINGO, ACTING DIRECTOR DPW
CITY OF PONTIAC**

INSTRUCTIONS TO BIDDERS

INDEX

Article

1. Proposal to be Received
2. Location of the Work
3. Inspection of the Site
4. Conformity to Plans, Specifications and Other Contract Documents
5. Basis on which Proposals are Solicited
6. Form of Proposal
7. Legal Status of Bidder
8. Agency
9. Bid Deposit
10. INTENTIONALLY LEFT BLANK
11. Statement of Bidder's Qualifications
12. Payments
13. Time of Completion
14. Right to Accept, to Reject, and to Waive Defects
15. Award of Contract
16. Obligation to Execute Contract
17. Bonds
18. Insurance
19. City Taxes
20. Pre-Bid Meeting
21. Purchasing Ordinance
22. Non-Discrimination Provision

INSTRUCTION TO BIDDERS

1. PROPOSALS TO BE RECEIVED

Sealed Bids or proposals for the:

Vanguard Drive Compacted Concrete Project

will be received at the office of the City Clerk of the City of Pontiac, Michigan until **1:00 p.m., EDT, on 24, June 2021**, and immediately thereafter will be publicly opened and read.

Each BID must be submitted in a sealed envelope, addressed to the City Clerk of the City of Pontiac. Each sealed envelope containing a BID must be plainly marked on the outside as:

“Vanguard Drive Compacted Concrete Project”

and the envelope should bear on the outside the name of the BIDDER, his address, his license number (if applicable) and the name of the project for which the BID is submitted. If forwarded by mail, the sealed envelope containing the BID must be enclosed in another envelope addressed to the City Clerk, City of Pontiac, 47450 Woodward Ave., Pontiac, MI 48342.

Bids will be received during regular business hours at the place and up to the time stated in the Advertisement or up to the time extended by official notification. Bids may be delivered in person or mailed, but their delivery is the bidder's entire responsibility. Any bid received after the stated hour, even through the mail, will be returned unopened to the bidder. Electronic bids will not be accepted.

No bidder may withdraw a bid within 90 days after the actual date of the opening thereof. Should there be reason why the contract cannot be awarded within the specified period, the time may be extended by mutual agreement between the City of Pontiac, herein after also referred to as the City, and the BIDDER.

2. LOCATION OF THE WORK

VANGUARD DRIVE
PONTIAC, MICHIGAN, 48341

3. INSPECTION OF THE SITE

It is expected that each bidder will make a personal examination of the entire site of the proposed work and of its surroundings. It will be assumed that each bidder, before offering his proposal, has obtained firsthand information concerning any probable interference and the available facilities for transporting, handling, and storing construction equipment and materials, and concerning other conditions which may affect his work.

4. CONFORMITY TO PLANS, SPECIFICATIONS AND CONTRACT DOCUMENTS

Proposals must be made in full conformity to all the conditions as set forth in the Plans, Specifications, and any Addendum for the work now on file in the office of the City Engineer. The CONTRACT DOCUMENTS contain the provisions required for the construction of the PROJECT. Information obtained from an officer, agent, or employee of the City or any other person shall not affect the risks or obligations assumed by the CONTRACTOR or relieve him from fulfilling any of the conditions of the contract.

Each BIDDER is responsible for inspecting the site and for reading and being thoroughly familiar with the CONTRACT DOCUMENTS. The failure or omission of any BIDDER to do any of the foregoing shall in no way relieve any BIDDER from any obligation in respect to his BID.

5. BASIS ON WHICH PROPOSALS ARE SOLICITED

A. PROPOSAL SOLICITATION

Proposals may be solicited on the basis of unit prices, lump sum, or a combination of both. The proposal will clearly state which basis is used.

The lump sum price, when applied to the project, or the unit prices, when applied to the several demolition or salvage items, are to make up the total price for the entire work, exclusive of those things which are to be done or furnished by the City, finished and complete in every particular, according to the Plans and Specifications appertaining to such work, which have been approved by the City Council and are now on file in the office of the City Engineer.

Where Proposals are solicited on the basis of unit prices for certain construction units, which are clearly set forth in the Form of Proposal, the Bidder shall state a unit price for each and every item listed in the Proposal and such prices shall be extended and totaled. If during the review of the Proposals, the City finds any errors in any extension or total, the City will make the necessary corrections and award the Contract on the basis of such corrections, since the unit prices shall govern. Any proposal which does not contain a unit price for each item listed will be deemed incomplete and will not be considered in the award of the Contract.

The unit price for each of the several items in the Proposal shall be such that the whole of the unit prices will represent a balanced bid. Any Proposal, in which the unit prices bid for any of the several items are deemed by the City to be manifestly unbalanced, will be subject to instant rejection.

B. STATEMENT OF QUANTITIES

The quantities indicated in the proposal show the Engineer's estimate of the construction quantities involved in the job, and bids will be computed, tested, and compared by the quantities given in the proposal. Although estimated carefully and with as much accuracy as is practicable beforehand, these quantities are not to be taken as defining or limiting the amount of work to be done under the Contract, but rather as information furnished to bidders concerning the approximate extent of the several items and as a basis for comparing bids.

The City may increase or decrease the original contract price without renegotiation of the Unit Prices.

C. MATERIALS TO BE FURNISHED BY THE CITY

The City will furnish to the Contractor, delivered at the site: NONE. The Contractor will receive and be responsible for all these materials from the time of their delivery to him until the time when they are received back by the City as part of the completed and accepted structure.

D. EXTRA WORK

All extra work that may be required of the Contractor will be estimated and paid for under provisions of the General Conditions, contained within this document, which govern such work.

E. ALTERNATES

When the Proposal so provides, a price shall be stated for each listed alternate. Unsolicited alternates are not to be submitted and, if so, will not be considered in the award of the Contract and may cause the entire bid to be rejected.

Selection of whether to award the Contract on the basis of the Base Bid or utilizing one or more of the Alternates will be made on the basis of value engineering and the City's need to keep project costs within the project budget. The City reserves full right to make this selection. After making such selection, the award shall be made on the basis of the lowest responsive bid utilizing the Alternates selected, and evaluated in accordance with the provisions of the Purchasing Ordinance of the City, in accordance with Article 15 of the Instructions to Bidders.

F. LEGAL CONDITIONS

All applicable laws, ordinances, and the rules and regulations of all authorities having jurisdiction over construction of the Project shall apply to the contract throughout.

G. PERMITS AND LICENSES

Permits and licenses of a temporary nature necessary for the prosecution of the WORK shall be secured and paid for by the CONTRACTOR unless otherwise stated in the SUPPLEMENTAL GENERAL CONDITIONS. Refer to **page 61 and 62** for further details.

H. UTILITIES

Unless otherwise provided in these Specifications, the Contractor shall make his own arrangements for electricity, gas, water and sewer services for use during the construction of the work and shall pay for all connections, extensions, and services.

6. FORM OF PROPOSALS (Pages 13 through 20)

All proposals must be made in the form attached hereto, and without removal from the bound pamphlet. Additional copies of this proposal form for the bidder's files may be obtained on request at the office Hubbell, Roth & Clark, Inc., 555 Hulet Drive, Bloomfield Hills., Michigan.

All prices stated in the Proposal must be plainly expressed in figures only, and in the proper space or spaces provided. Prices shall be filled in, in ink or typewritten. Any corrections shall be initialed by the Bidder.

All information called for on the Proposal must be furnished to enable a fair comparison of the bids to be made. (Also see Instructions to Bidders.)

The place of residence and phone number of each bidder, or the official address and phone number in the case of a firm or company, with County and State, must be given with the signature.

When bidder's drawings and/or specifications are required to be submitted, they shall be in sufficient detail to fully and distinctly show and describe the equipment which the bidder proposes to furnish, including the kind and quality of the material and workmanship that will be used in the various parts. If any general drawings, specifications, catalogs or any other literature are submitted which contain information or data not pertaining to the particular equipment proposed to be furnished, appropriate notations to that effect must be made.

Any stipulation or qualification contrary to the Contract requirements made by the bidder in or accompanying his proposal as a condition for the acceptance of the Contract will not be considered in the award of the Contract and may cause the rejection of the entire Proposal.

7. LEGAL STATUS OF BIDDER

The legal status of the bidder, that is, as a corporation, a partnership, or an individual, must be stated in the proposal. A corporation bidder must name the state in which its articles of incorporation are held, and must give the title of the official having authority under the by-laws to sign contracts. A partnership bidder must give the full names and addresses of all partners.

8. AGENCY

Anyone signing a proposal as agent of another or others must submit with the proposal legal evidence of his or her authority to do so.

9. BID DEPOSIT

When the Advertisement states that security is required with the Proposal to ensure the acceptance and execution of the Contract and Bonds, no bid will be considered complete unless so guaranteed.

Each proposal must be accompanied by a certified check of guaranty or a bid bond in an amount not less than five percent (5%) of the total price, drawn upon a solvent bank to the order of the City Treasurer of the City of Pontiac, or if a bond, executed by a surety company

acceptable to the City, as a guarantee of good faith on the part of the bidder and subject to the conditions stipulated in the proposal form.

A single certified check or guaranty (bidder's) bond may serve to cover two or more alternative proposals when such alternative proposals are submitted by the same bidder.

10. INTENTIONALLY LEFT BLANK

11. STATEMENT OF BIDDER'S QUALIFICATIONS

It is the intention of the City to award the Contract for this job to a Contractor whose construction skill and financial resources are fully equal to the task of prosecuting the work in a satisfactory manner and of bringing it to completion within the time limit specified. With this end in view, the Form of Proposal calls for a statement of bidder's experience and ability in this particular class of work, and for references concerning his/her business standing and capacity. Contractor shall list the names, addresses and phone numbers of references. The mere ability to offer bonds will not be taken as sufficient evidence of responsibility on the part of the bidder. If Contract is awarded to a foreign company, a certificate of authority to do business in this State must accompany the executed Contract.

The low BIDDER shall supply the names, addresses and phone numbers of major material SUPPLIERS and SUBCONTRACTORS when requested to do so by the CITY.

12. PAYMENTS

Partial payments will be made to the Contractor during the satisfactory progress of the work, calculated at the rate of ninety percent (90%) of the dollar amount of the work completed, until fifty percent (50%) of the established contract amount is in place. After fifty percent (50%) of the work is in place, additional retainage shall not be withheld unless the Contractor's progress is unsatisfactory, all in accordance with Article 13 of the General Conditions hereof and Act 524 of 1980.

13. TIME OF COMPLETION

This work to be done under the proposed Contract is to begin on or before the date stipulated in the Notice to Proceed and must be completed within **60 calendar days**, unless the date for completion is extended by the Contract Documents. Time shall be considered to be of the essence of this Contract.

14. RIGHT TO ACCEPT, TO REJECT, AND TO WAIVE DEFECTS

The City reserves the right to accept any proposal, to reject any or all proposals, and to waive any defect or irregularity in any proposal if it appears advantageous to the City to do so. In particular, any alteration, erasure, or interlineation in the Form of Contract in the Specifications which are attached hereto and made a part, specifically, of these Instructions, or of the Form of Proposal, shall render the accompanying proposal irregular and subject to rejection by the City. In case any explanations, additions or alterations are to be offered, they shall be indicated on separate sheets attached to the proposal and referred to therein. Proposals which are clearly unbalanced will also be considered as irregular, and will be subject to instant rejection by the City.

15. AWARD OF CONTRACT

The Contract will be awarded to the qualified Bidder submitting the lowest responsive Bid complying with the conditions of the Invitation for Bids and Pontiac Purchasing Ordinance. The Bidder's qualification and responsiveness shall be determined by the City of Pontiac. The Bidder to whom the award is made will be notified at the earliest possible date. The City reserves the right to reject all bids and not award the Contract, at its sole discretion.

16. OBLIGATION TO EXECUTE CONTRACT

The Bidder whose proposal is accepted will be required to execute the Contract, in the form attached hereto, and to furnish sureties as hereafter specified, within ten days (Sundays and legal holidays excepted), after receiving notice of acceptance of bid and preparation Contract forms is completed, and in case of the successful bidder's refusal or failure to do so, shall be considered to have abandoned all their rights and interests in the award, and their certified check or guaranty (bidder's) bond may be declared to be forfeited to the City as liquidated damages and not a penalty, and the Contract may be awarded to another.

17. BONDS

The successful bidder will be required to execute surety bonds, with sureties acceptable to the City. One such bond shall be a Performance Bond in the amount of 100 percent of the Contract Price on the form attached as pages 25 and 26 of the specifications. Another such bond shall be a Labor and Material Bond in the amount of 100 percent of the Contract Price on the form attached as pages 27 and 28 of the specifications. The Contractor shall also provide a Maintenance Bond in the amount of 100 percent of the Contract Price on the form attached as pages 29 and 30 of the specifications.

18. INDEMNIFICATION AND INSURANCE

To the fullest extent permitted by law, the successful bidder agrees to defend, pay on behalf of, indemnify, and hold harmless the CITY OF PONTIAC, it's elected and appointed officials, employees and volunteers and others working on behalf of the CITY OF PONTIAC, against any and all claims, demands, suits, or loss, including all costs connected therewith, and for any damages which may be asserted, claimed or recovered against or from the CITY OF PONTIAC, it's elected and appointed officials, employees, volunteers or others working on behalf of the CITY OF PONTIAC, by reason of personal injury, including bodily injury and death, and/or property damage, including loss of use thereof, which arises out of or is in any way connected or associated with this contract.

The successful bidder shall purchase and maintain in a company or companies licensed to do business in the State of Michigan, such insurance as will protect him from claims set forth below which may arise out of or result from the contractor's operations under the contract, whether such operations be by himself or any subcontractor or by anyone directly or indirectly employed by any of them, or by anyone whose acts are associated with the project by any of them, may be liable.

a. Workers Compensation Insurance: The contractor shall procure and maintain during the life of the contract, Workers Compensation Insurance, including Employer's Liability Coverage, in accordance with all applicable statutes of the State of Michigan.

b. Commercial General Liability Insurance: The contractor shall procure and maintain during the life of this contract, Commercial General Liability Insurance on an "Occurrence Basis" with the limits of liability not less than **\$2,000,000**, per occurrence and/or aggregate combined single limit, Personal Injury, Bodily Injury and Property Damage. Coverage shall include the following extensions: (1) Contractual Liability; (2) Products and Completed Operations; (3) Independent Contractors Coverage; (4) Broad Form General Liability Extensions or equivalent; and (5) Deletion of all Explosion, Collapse and Underground (XCU) Exclusions. if applicable.

c. Motor Vehicle Liability: The contractor shall procure and maintain during the life of the contract, Motor Vehicles Liability Insurance, including Michigan No-Fault coverage, with limits of not less than **\$2,000,000**, per occurrence combined single limit Bodily Injury and Property Damage. Coverage shall include all owned vehicles, all non- owned vehicles and all hired vehicles.

d. Additional Insured: Commercial General Liability and Motor Vehicle Liability Insurance, as described above, shall include an endorsement stating the following shall be **"Additional Insured"**. *"THE CITY OF PONTIAC, INCLUDING ALL ELECTED AND APPOINTED OFFICIALS, ALL EMPLOYEES AND VOLUNTEERS, ALL BOARDS, COMMISSIONS AND/OR AUTHORITIES AND THEIR BOARD MEMBERS, EMPLOYEES AND VOLUNTEERS" AND HUBBELL, ROTH & CLARK, INC., the project consultant.* (This coverage shall be primary to the Additional Insured, and not contributing with any other insurance or similar protection available to the Additional Insureds, whether said other available coverage be primary, contributing or excess.)

e. Cancellation Notice: Workers Compensation Insurance, Commercial General Liability Insurance, and Motor Vehicle Insurance, as described above, shall include an endorsement stating the following: *"IT IS UNDERSTOOD AND AGREED THAT **THIRTY (30) DAYS ADVANCE WRITTEN NOTICE OF CANCELLATION, NON-RENEWAL, REDUCTION AND/OR MATERIAL CHANGE SHALL BE SENT TO: CITY OF PONTIAC, RISK MANAGEMENT DIVISION, 47450 WOODWARD AVE., PONTIAC, MICHIGAN, 48342"**.*

f. Owner's and Contractor's Protective Liability: The contractor shall procure and maintain during the life of this contract, a separate Owner's and Contractor's Protective Liability insurance coverage of not less than \$2,000,000, per occurrence and/or aggregate, combined single limit, Personal Liability, Bodily Injury, and Property Damage. The City of Pontiac shall be "Named Insured" on said coverage. Thirty (30) days Notice of Cancellation shall apply to this policy.

The successful bidder shall not commence work until he has obtained the insurance required under this section, nor shall the successful bidder permit any subcontractor to commence work on his subcontract until the insurance required of the subcontractor has been obtained.

Certificates of Insurance, along with copies of original policies where applicable, acceptable to the City, shall be filed with the City of Pontiac, Risk Management Division, ten (10) days prior to commencement of the contract. A sample certificate is included on page 12 for reference.

19. CITY INCOME TAX

a. Contractor agrees to contact City of Pontiac Income Tax Division, Audit and Compliance Section, 47450 Woodward Avenue, Pontiac, Michigan, 48342, telephone (248) 758-3236, to establish reporting and withholding obligations under the City of Pontiac Income Tax Ordinance. Contractor will require the same of all subcontractors employing labor under this contract.

b. Normally, the Contractor will be required to withhold City of Pontiac income tax if either of the following applies:

- (1) Performance under this contract (together with any other contracts in the City during the calendar year) will last 13 weeks or more.

(2) Contractor employs one or more Pontiac residents for the performance of this contract.

c. Contractor agrees to pay any personal property taxes required by the City Assessor.

20. PRE-BID MEETING

A pre-bid meeting will be scheduled by **Addendum 1** with meeting instructions.

21. CITY OF PONTIAC PURCHASING ORDINANCE (Chapter 2, Article VI, Division 2) Municipal Code, City of Pontiac, Michigan, adopted March 21, 1996 and effective March 31, 1996.

Bidders are advised of the following provisions of the Purchasing Ordinance:

a. PUBLIC BIDS - EQUALIZATION PERCENTAGE CREDIT

An "equalization percentage credit" will be allowed for bids of Pontiac-based bidders. This means that bids by Pontiac-based bidders will be compared as if they were two percent (2%) less than their actual amount. The equalization percentage credit will be one percent (1%) if the lowest bid is \$100,000 or above. Not applicable to emergency purchases. Successful Pontiac - based bidder awarded on this basis may not sublet to non-Pontiac-based business.

b. CONTRACTOR OR VENDOR IN DEFAULT OR INDEBTED TO THE CITY

No bid shall be accepted from or contract awarded to any contractor or vendor who is in arrears to the City upon debt or contract including payments of real property taxes or an income tax obligation of any kind, or who is in default as to security or otherwise upon an obligation to the City.

c. VIOLATIONS - MISREPRESENTATION

Any material misrepresentation to the City of Pontiac by a bidder or prospective bidder, contractor or vendor in any documentation or paperwork submitted in a bid or proposal or otherwise in connection with an attempt to obtain a contract or engage in a business transaction shall be a violation, and may be considered sufficient basis to disqualify the contractor or vendor from eligibility for the award of a City contract.

22. NON-DISCRIMINATION PROVISION

Pursuant to the requirements of 1976, P.A. 453 (Michigan Civil Rights Act) and 1976, P.A. 220 (Michigan Handicapped Rights Act), the bidder and any subcontractors agree not to discriminate against any employee or applicant for employment with respect to hire, tenure, terms, conditions, or privileges of employment or a matter directly or indirectly related to employment, because of race, color, religion, national origin, age, sex, height, weight, marital status, or due to a handicap that is unrelated to the person's ability to perform the duties of a particular job or position. The Bidder must include this provision in any subcontracts associated with the project work

SAMPLE CERTIFICATE OF INSURANCE

| <b style="font-size: 1.2em;">CERTIFICATE OF LIABILITY INSURANCE | | DATE (MM/DD/YYYY) 11/05/2018 | | | | | | | | | | | | | | |
|---|---|---------------------------------|-------------------------------|---|---|--|------------|--|------------|--|------------|--|------------|--|------------|--|
| THIS CERTIFICATE IS ISSUED AS A MATTER OF INFORMATION ONLY AND CONFERS NO RIGHTS UPON THE CERTIFICATE HOLDER. THIS CERTIFICATE DOES NOT AFFIRMATIVELY OR NEGATIVELY AMEND, EXTEND OR ALTER THE COVERAGE AFFORDED BY THE POLICIES BELOW. THIS CERTIFICATE OF INSURANCE DOES NOT CONSTITUTE A CONTRACT BETWEEN THE ISSUING INSURER(S), AUTHORIZED REPRESENTATIVE OR PRODUCER, AND THE CERTIFICATE HOLDER. | | | | | | | | | | | | | | | | |
| IMPORTANT: If the certificate holder is an ADDITIONAL INSURED, the policy(ies) must have ADDITIONAL INSURED provisions or be endorsed. If SUBROGATION IS WAIVED, subject to the terms and conditions of the policy, certain policies may require an endorsement. A statement on this certificate does not confer rights to the certificate holder in lieu of such endorsement(s). | | | | | | | | | | | | | | | | |
| PRODUCER FEDERATED MUTUAL INSURANCE COMPANY HOME OFFICE: P.O. BOX 328 OWATONNA, MN 55060 | CONTACT NAME: CLIENT CONTACT CENTER PHONE (A/C, No, Ext): 888-333-4949 FAX (A/C, No): 507-446-4684 E-MAIL ADDRESS: CLIENTCONTACTCENTER@FEDINS.COM <table border="1" style="width: 100%; border-collapse: collapse;"> <tr> <th style="text-align: left;">INSURER(S) AFFORDING COVERAGE</th> <th style="text-align: left;">NAIC #</th> </tr> <tr> <td>INSURER A: FEDERATED MUTUAL INSURANCE COMPANY</td> <td>13935</td> </tr> <tr> <td>INSURER B:</td> <td></td> </tr> <tr> <td>INSURER C:</td> <td></td> </tr> <tr> <td>INSURER D:</td> <td></td> </tr> <tr> <td>INSURER E:</td> <td></td> </tr> <tr> <td>INSURER F:</td> <td></td> </tr> </table> | | INSURER(S) AFFORDING COVERAGE | NAIC # | INSURER A: FEDERATED MUTUAL INSURANCE COMPANY | 13935 | INSURER B: | | INSURER C: | | INSURER D: | | INSURER E: | | INSURER F: | |
| INSURER(S) AFFORDING COVERAGE | NAIC # | | | | | | | | | | | | | | | |
| INSURER A: FEDERATED MUTUAL INSURANCE COMPANY | 13935 | | | | | | | | | | | | | | | |
| INSURER B: | | | | | | | | | | | | | | | | |
| INSURER C: | | | | | | | | | | | | | | | | |
| INSURER D: | | | | | | | | | | | | | | | | |
| INSURER E: | | | | | | | | | | | | | | | | |
| INSURER F: | | | | | | | | | | | | | | | | |
| INSURED | 157-615-8 | | | | | | | | | | | | | | | |
| COVERAGES | | REVISION NUMBER: 0 | | | | | | | | | | | | | | |
| THIS IS TO CERTIFY THAT THE POLICIES OF INSURANCE LISTED BELOW HAVE BEEN ISSUED TO THE INSURED NAMED ABOVE FOR THE POLICY PERIOD INDICATED. NOTWITHSTANDING ANY REQUIREMENT, TERM OR CONDITION OF ANY CONTRACT OR OTHER DOCUMENT WITH RESPECT TO WHICH THIS CERTIFICATE MAY BE ISSUED OR MAY PERTAIN, THE INSURANCE AFFORDED BY THE POLICIES DESCRIBED HEREIN IS SUBJECT TO ALL THE TERMS, EXCLUSIONS AND CONDITIONS OF SUCH POLICIES. LIMITS SHOWN MAY HAVE BEEN REDUCED BY PAID CLAIMS. | | | | | | | | | | | | | | | | |
| INSR LTR | TYPE OF INSURANCE | ADDL SUBR INSR WVD | POLICY NUMBER | POLICY EFF (MM/DD/YYYY) | POLICY EXP (MM/DD/YYYY) | LIMITS | | | | | | | | | | |
| A | <input checked="" type="checkbox"/> COMMERCIAL GENERAL LIABILITY <input type="checkbox"/> CLAIMS-MADE <input checked="" type="checkbox"/> OCCUR GEN'L AGGREGATE LIMIT APPLIES PER: <input checked="" type="checkbox"/> POLICY <input type="checkbox"/> PRO-JECT <input type="checkbox"/> LOC OTHER: | Y N | 60689355 | 04/01/2018 | 04/01/2019 | EACH OCCURRENCE \$1,000,000 DAMAGE TO RENTED PREMISES (Per occurrence) \$100,000 MED EXP (Any one person) EXCLUDED PERSONAL & ADV INJURY \$1,000,000 GENERAL AGGREGATE \$2,000,000 PRODUCTS - COMP/OP AGO \$2,000,000 | | | | | | | | | | |
| A | <input checked="" type="checkbox"/> AUTOMOBILE LIABILITY <input checked="" type="checkbox"/> ANY AUTO <input type="checkbox"/> OWNED AUTOS ONLY <input type="checkbox"/> SCHEDULED AUTOS <input type="checkbox"/> HIRED AUTOS ONLY <input type="checkbox"/> NON-OWNED AUTOS ONLY <input type="checkbox"/> | N N | 60689355 | 04/01/2018 | 04/01/2019 | COMBINED SINGLE LIMIT (Per accident) \$1,000,000 BODILY INJURY (Per person) BODILY INJURY (Per accident) PROPERTY DAMAGE (Per accident) | | | | | | | | | | |
| A | <input checked="" type="checkbox"/> UMBRELLA LIAB <input checked="" type="checkbox"/> OCCUR <input type="checkbox"/> EXCESS LIAB <input type="checkbox"/> CLAIMS-MADE DED RETENTION | N N | 60689357 | 04/01/2018 | 04/01/2019 | EACH OCCURRENCE \$1,000,000 AGGREGATE \$1,000,000 | | | | | | | | | | |
| A | WORKERS COMPENSATION AND EMPLOYERS' LIABILITY ANY PROPRIETOR/PARTNER/EXECUTIVE OFFICER/MEMBER EXCLUDED? (Mandatory in MI) If yes, describe under DESCRIPTION OF OPERATIONS below | Y / N / A | 60689358 | 04/01/2018 | 04/01/2019 | <input checked="" type="checkbox"/> PER STATUTE <input type="checkbox"/> OTHER E.L. EACH ACCIDENT \$500,000 E.L. DISEASE - EA EMPLOYEE \$500,000 E.L. DISEASE - POLICY LIMIT \$500,000 | | | | | | | | | | |
| DESCRIPTION OF OPERATIONS / LOCATIONS / VEHICLES (ACORD 101, Additional Remarks Schedule, may be attached if more space is required) RE: 350 S SANFORD THE CERTIFICATE HOLDER IS AN ADDITIONAL INSURED SUBJECT TO THE CONDITIONS OF THE ADDITIONAL INSURED - OWNERS, LESSEES OR CONTRACTORS - AUTOMATIC STATUS WHEN REQUIRED IN CONSTRUCTION AGREEMENT WITH YOU ENDORSEMENT FOR GENERAL LIABILITY. | | | | | | | | | | | | | | | | |
| CERTIFICATE HOLDER | | | | CANCELLATION | | | | | | | | | | | | |
| 157-615-0 CITY OF PONTIAC 47450 WOODWARD AVE PONTIAC, MI 48342-5009 | | | | 62 0 SHOULD ANY OF THE ABOVE DESCRIBED POLICIES BE CANCELLED BEFORE THE EXPIRATION DATE THEREOF, NOTICE WILL BE DELIVERED IN ACCORDANCE WITH THE POLICY PROVISIONS. AUTHORIZED REPRESENTATIVE | | | | | | | | | | | | |

© 1988-2015 ACORD CORPORATION. All Rights reserved.

CONTRACTOR: _____

FORM OF PROPOSAL

Date: _____

To the Honorable Mayor / City Council
City of Pontiac, Michigan

Ladies and Gentlemen:

Having carefully examined the site of the proposed work, and being fully informed in regard to the conditions to be met in the prosecution and completion of the work, and having read and examined the Instructions to Bidders, Agreement, Bonds, General Conditions, Plans and Specifications pertaining to this work, and agreeing to be bound accordingly, the undersigned proposes to furnish all the materials, labor, tools, power, transportation and construction equipment necessary for the satisfactory and complete construction of the **Vanguard Drive Compacted Concrete Project** in full accordance with and conformity to the specifications for this work now on file in the office of the City Engineer at and for the following named prices, to wit:

| Item No. | Description | Quantity | Unit | Unit Price | Bid Amount |
|----------|--|----------|------|------------|------------|
| 1. | Mobilization, Max. 10% | 1 | LS | \$ | _____ |
| 2. | Pavt, Rem | 4,776 | Syd | \$ | _____ |
| 3. | Exploratory Investigation, Vertical | 25 | Ft | \$ | _____ |
| 4. | Embankment, CIP | 455 | Cyd | \$ | _____ |
| 5. | Excavation, Earth | 1,078 | Cyd | \$ | _____ |
| 6. | Erosion Control, Inlet Protection, Fabric Drop | 9 | Ea | \$ | _____ |
| 7. | Project Cleanup, Special | 1 | LS | \$ | _____ |
| 8. | Aggregate Base, 8 inch | 4,650 | Syd | \$ | _____ |
| 9. | Aggregate Base, Conditioning | 3,793 | Syd | \$ | _____ |
| 10. | Maintenance Gravel | 72 | Ton | \$ | _____ |

| Item No. | Description | Quantity | Unit | Unit Price | Bid Amount |
|----------|--|----------|------|------------|------------|
| 11. | Sewer Tap, 12 inch | 1 | Ea | \$ | _____ |
| 12. | Dr Structure Cover, Adj, Case 1 | 5 | Ea | \$ | _____ |
| 13. | Dr Structure Cover, Adj, Case 2 | 1 | Ft | \$ | _____ |
| 14. | Dr Structure Cover, Type G | 1 | Ea | \$ | _____ |
| 15. | Dr Structure Cover, Type K | 6 | Ea | \$ | _____ |
| 16. | Dr Structure, 24 inch dia | 1 | Ea | \$ | _____ |
| 17. | Dr Structure, Adj, Add Depth | 10 | Ft | \$ | _____ |
| 18. | Underdrain, Subgrade, Open-Graded, 6 inch, Special | 1,340 | Ft | \$ | _____ |
| 19. | HMA Surface, Rem | 24 | Syd | \$ | _____ |
| 20. | Hand Patching | 6 | Ton | \$ | _____ |
| 21. | Compacted Conc Pavt, 9 inch | 3,793 | Syd | \$ | _____ |
| 22. | Curb and Gutter, Conc, Det F4 | 2,327 | Ft | \$ | _____ |
| 23. | Driveway Opening, Conc, Det M | 140 | Ft | \$ | _____ |
| 24. | Barricade, Type III, High Intensity, Double Sided, Lighted, Furn, Modified | 19 | Ea | \$ | _____ |
| 25. | Barricade, Type III, High Intensity, Double Sided, Lighted, Oper, Modified | 19 | Ea | \$ | _____ |
| 26. | Channelizing Device, 42 inch, Fluorescent, Furn, Modified | 108 | Ea | \$ | _____ |
| 27. | Channelizing Device, 42 inch, Fluorescent, Oper, Modified | 108 | Ea | \$ | _____ |
| 28. | Lighted Arrow, Type C, Furn, Modified | 1 | Ea | \$ | _____ |
| 29. | Lighted Arrow, Type C, Oper, Modified | 1 | Ea | \$ | _____ |
| 30. | Minor Traf Devices | 1 | LS | \$ | _____ |
| 31. | Plastic Drum, Fluorescent, Furn, Modified | 45 | Ea | \$ | _____ |

| Item No. | Description | Quantity | Unit | Unit Price | Bid Amount |
|----------------------------|--|----------|------|------------|------------|
| 32. | Plastic Drum, Fluorescent, Oper, Modified | 45 | Ea | \$ | _____ |
| 33. | Sign Type B, Temp, Prismatic, Furn, Modified | 288 | Sft | \$ | _____ |
| 34. | Sign Type B, Temp, Prismatic, Oper, Modified | 288 | Sft | \$ | _____ |
| 35. | Traf Regulator Control | 1 | LS | \$ | _____ |
| 36. | Seeding, Mixture THM | 45 | Lb | \$ | _____ |
| 37. | Fertilizer, Chemical Nutrient, Cl B | 45 | Lb | \$ | _____ |
| 38. | Topsoil Surface, Furn, 2 inch | 90 | Syd | \$ | _____ |
| 39. | Mulch Blanket | 90 | Syd | \$ | _____ |
| 40. | Water, Sodding/Seeding | 1.6 | Unit | \$ | _____ |
| 41. | Traf Loop | 4 | Ea | \$ | _____ |
| 42. | TS Head, Temp | 1 | Ea | \$ | _____ |
| 43. | TS Face, Bag | 1 | Ea | \$ | _____ |
| 44. | TS Face, Bag, Rem | 1 | Ea | \$ | _____ |
| 45. | Sprinkler Line, Modified | 100 | Ft | \$ | _____ |
| 46. | Sprinkler Head, Replace, Modified | 6 | Ea | \$ | _____ |
| 47. | Sprinkler Head, Relocate, Modified | 6 | Ea | \$ | _____ |
| TOTAL AMOUNT OF BID | | | | | _____ |

Contractor acknowledges receipt of the following Addendum(s):

Addendum No.: _____ Dated: _____
 Addendum No.: _____ Dated: _____
 Addendum No.: _____ Dated: _____

The Contractor acknowledges that he has not received nor relied upon any representations or warranties of any nature whatsoever from the City of Pontiac, its officers, employees or agents and that if he is awarded this contract, he shall enter into this Contract solely as the result of his own independent business judgment.

The undersigned acknowledges that he has made his own independent investigation and has satisfied himself as to the conditions of the work, including soil and subsurface conditions.

The undersigned agrees that, in case any additions or deductions in the amount of work contemplated are made, the above named unit prices for the various classes of work shall be used to allow for such additions or deductions.

The undersigned hereby agrees that if this Proposal shall be accepted by the said City, he will, within ten days after receiving notice of such acceptance and delivery of Contract forms thereof at the address given below (Sundays and legal holidays excepted), enter into contract, in the attached form, to construct the said work according to said plans and specifications and to furnish therefor all necessary equipment, tools and building appliances, materials, labor, power and transportation as aforesaid at and for the prices named in the foregoing paragraph; to furnish to the said City and to the State of Michigan such sureties for the faithful performance of such Contract and for the payment of all materials used therein and for all labor expended thereon as shall be approved and accepted by the said City; and to furnish to the said City of Pontiac a Maintenance Bond.

The undersigned attaches hereto a (certified check), (bidder's bond), in the sum of:

Dollars (\$ _____)

as required in the Instructions to Bidders. And the undersigned hereby agrees that, in case he shall fail to fulfill his obligations under the foregoing proposal and agreement, the said City may, at its option, determine that the undersigned has abandoned his rights and interests in such contract and that the certified check or bidder's bond accompanying this proposal has been forfeited to the said City as liquidated damages and not as a penalty; but, otherwise

The undersigned states that he currently owns or intends to rent the following equipment that will be used in work covered by this proposal:

List of Equipment Owned

List of Intended Rental Equipment

The undersigned states that he has done work similar in character to that covered by this proposal at the following named times and places, to wit:

The undersigned refers the said City to the following named parties for information concerning his experience, skill and business standing:

NAME, ADDRESS AND PHONE NUMBER:

Dated and signed at _____, MI on _____
(City) (Date)

Name of Bidder: _____

Address of Bidder: _____

By: _____

Title: _____

Telephone#: _____ Fax#: _____

Email: _____

Federal Tax I.D. Number (_____)

CERTIFICATIONS

IF A CORPORATION

I, _____, certify that I am the _____ of the corporation named as Contractor herein; that _____, who signed this Agreement on behalf of the Contractor, was then _____ of said corporation; that said Agreement was duly signed for and in behalf of said corporation by authority of its governing body, and is within the scope of its corporate powers.

Corporate Seal

Signature

IF A PARTNERSHIP

I, _____, certify that I am a partner in the partnership named as Contractor herein, and that I have authority to sign for and on behalf of this partnership consisting of the following partners:

NAME AND ADDRESS:

Signature

IF A SOLE PROPRIETORSHIP

I, _____, certify that I am the sole owner and proprietor.

Signature

Bidder _____

Approximate Duration of Project ___ days

INTENTIONALLY LEFT BLANK

BIDDER'S PARTICIPATION PLAN (continued)

SUBCONTRACTING AND PROCUREMENT

The following is the bidder's analysis of all substantial subcontracting and procurement opportunities that are expected on the project (including major supply or rental items). Dollar estimates shown are approximate. Larger second tier items are also included.

| (1) | (2) | (3) |
|--|-----------------|---------|
| Procurement or Subcontract Item (Type) | Dollar Estimate | Comment |
| | | |
| | | |
| | | |
| | | |
| | | |
| | | |
| | | |
| | | |
| | | |
| | | |

Check here to acknowledge the requirement for a final Subcontractor/Supplier schedule to be executed by the bidder and accepted by the City prior to the execution of the contract for this project.

This plan for participation is part of the proposal submitted this date

Name of Bidder Name of Signer Signature Date

INTENTIONALLY LEFT BLANK

BID BOND

KNOW ALL MEN BY THESE PRESENTS, that we, the undersigned, _____
_____ as Principal,
and _____ as Surety, are
hereby held and firmly bound unto the City of Pontiac, Michigan, as OWNER in the
penal sum of:

_____ Dollars (\$ _____)

for the payment of which, well and truly to be made, we hereby jointly and severally bind
ourselves, successors and assigns. Signed, this _____ day of _____, 20 _____.

The Condition of the above obligation is such that whereas the Principal has
submitted to the City of Pontiac, Michigan, a certain BID, attached hereto and hereby
made a part hereof to enter into a contract in writing, for the

NOW, THEREFORE,

(a) If said BID shall be rejected, or

(b) If said BID shall be accepted and the Principal shall execute and deliver a
contract in the Form of Contract attached hereto (properly completed in
accordance with said BID) and shall furnish a BOND for his faithful performance
of said contract, and for the payment of all persons performing labor or furnishing
materials in connection therewith, and shall in all respects perform the agreement
created by the acceptance of said BID, then this obligation shall be void,
otherwise the same shall remain in force and effect; it being expressly understood
and agreed that the liability of the Surety for any and all claims hereunder shall, in
no event, exceed the penal amount of this obligation as herein stated.

The Surety, for value received, hereby stipulates and agrees that the obligations of said Surety and its BOND shall be in no way impaired or affected by any extension of the time within which the OWNER may accept such BID; and said Surety does hereby waive notice of any such extension.

IN WITNESS WHEREOF, the Principal and the Surety have hereunto set their hands and seals, and such of them as are corporations have caused their corporate seals to be hereto affixed and these presents to be signed by their proper officers, the day and year first set forth above.

_____(L.S)
Principal

_____(L.S.)
Surety

By: _____

IMPORTANT - Surety companies executing BONDS must appear on the Treasury Department's most current list (Circular 540 as amended) and be authorized to transact business in the State of Michigan.

AGREEMENT

THIS AGREEMENT, made this _____ day of _____, 20__, by and between the City of Pontiac, Oakland County, Michigan, party of the first part, hereafter called the City, and _____, Michigan, party of the second part, hereinafter called the Contractor:

WITNESSETH: That for and in consideration of the payments and agreements hereinafter mentioned:

1. The CONTRACTOR shall commence and complete the construction of:

in full conformance with the Contract Documents as enumerated in Article 6 of this Agreement.

2. The CONTRACTOR shall furnish all of the material, supplies, tools, equipment, labor and other services necessary for the construction and completion of the PROJECT described herein, excepting those things which are specifically stipulated in the contract documents to be furnished or done by the City.

3. The CONTRACTOR shall commence the work required by the CONTRACT DOCUMENTS on or before the date stipulated in the NOTICE TO PROCEED and will complete the same within **60 calendar days**, unless the date for completion is extended otherwise by the CONTRACT DOCUMENTS. Time shall be considered to be of the essence of this Contract.

4. The CONTRACTOR agrees to perform all of the WORK described in the CONTRACT DOCUMENTS and comply with the terms therein for the contract price of:

_____ (\$ _____)

unless the contract price is duly changed by the contract documents.

5. The CITY shall pay to the CONTRACTOR in the manner and at such times as set forth in the General Conditions such amounts as required by the CONTRACT DOCUMENTS.

6. The term "CONTRACT DOCUMENTS" means and includes the following:

- A. AGREEMENT
- B. BID BOND
- C. PERFORMANCE BOND
- D. LABOR AND MATERIAL BOND

- E. MAINTENANCE BOND
- F. CHANGE ORDER (Pursuant to General Conditions, Section 9)
- G. ADDENDA:
 - No. _____, dated _____, 20____ .
 - No. _____, dated _____, 20____ .
 - No. _____, dated _____, 20____ .
- H. ADVERTISEMENT
- I. INSTRUCTIONS TO BIDDERS
- J. BIDDER'S PROPOSAL
- K. GENERAL CONDITIONS (Incl. SUPPLEMENTAL GENERAL CONDITIONS and SPECIAL CONDITIONS (if any))
- L. SPECIFICATIONS (Incl. SUPPLEMENTAL SPECIFICATIONS and SPECIAL PROVISIONS (if any))
- M. PLANS (As listed in Schedule of Drawings)
- N. NOTICE OF AWARD
- O. NOTICE TO PROCEED

This agreement, together with other documents enumerated in this ARTICLE 6, which said other documents are as fully a part of the Contract as if hereto attached or herein repeated, forms the Contract between the parties hereto. In the event that any provision in any component part of this Contract conflicts with any provision of any other component part, the provision of the component part first enumerated in this ARTICLE 6 shall govern, except as otherwise specifically stated.

7. This Agreement shall be binding upon all parties hereto and their respective heirs, executors, administrators, successors, and assigns.

IN WITNESS WHEREOF, the parties hereto have executed, or caused to be executed by their duly authorized officials, this Agreement in three (3) copies, each of which shall be deemed an original, on the date first above written.

**CONTRACT AGREEMENT BETWEEN THE CITY OF PONTIAC
AND CONTRACTOR**

VANGUARD DRIVE COMPACTED CONCRETE PROJECT

CONTRACTOR: _____

In witness whereof, the parties have executed this agreement the day and year last written below.

WITNESSES:

1) _____ By: _____
2) _____ Its: _____

CITY OF PONTIAC

WITNESSES:

DEPARTMENT OF PUBLIC WORKS

1) _____ By: _____
Dan Ringo Date
2) _____ Its: Acting Director

WITNESSES:

DEPARTMENT OF FINANCE

1) _____ By: _____
Darin Carrington Date
2) _____ Its: Finance Director

WITNESSES:

RISK MANAGEMENT DIVISION

1) _____ By: _____
Date
2) _____ Its: Risk Management Administrator

WITNESSES:

OFFICE OF THE MAYOR

1) _____ By: _____
Dierdre Waterman Date
2) _____ Its: Mayor

Approved as to form:

By: _____
_____, City Attorney

CERTIFICATIONS

IF A CORPORATION

I, _____, certify that I am the _____ of the corporation named as Contractor herein; that _____, who signed this Agreement on behalf of the Contractor, was then _____ of said corporation; that said Agreement was duly signed for and in behalf of said corporation by authority of its governing body, and is within the scope of its corporate powers.*

Corporate Seal

Signature

* Attach copy of corporate resolution verifying authorization of individuals named above.

IF A PARTNERSHIP

I, _____, certify that I am a partner in the partnership named as Contractor herein, and that I have authority to sign for and on behalf of this partnership consisting of the following partners:

NAME AND ADDRESS:

Signature

IF A SOLE PROPRIETORSHIP

I, _____, certify that I am the sole owner and proprietor.

Signature

BOND FOR FAITHFUL PERFORMANCE

KNOW ALL MEN BY THESE PRESENTS, That _____

_____ as principal, and

_____, as surety, are held and

firmly bound unto the City of Pontiac, Michigan, a Municipal Corporation, in the sum of:

_____ good and lawful money of the United States of America, to be paid to said City of Pontiac, its legal representatives and assigns, for which payment well and truly to be made, we bind ourselves, our heirs, executors, administrators, successors, and assigns, and each and every one of them, jointly and severally, firmly by these presents.

Sealed with our Seals and dated this _____ day of _____ A.D. 20 _____.

WHEREAS, the above named principal has entered into a certain written contract with the City of Pontiac, dated this _____ day of _____ A.D. 20 _____, wherein the said principal covenanted and agreed as follows, to-wit:

TO COMMENCE AND COMPLETE the:

Vanguard Drive Compacted Concrete Project

NOW, THEREFORE, THE CONDITION OF THIS OBLIGATION IS such that if the above named principal or their legal representatives or successors, shall in all things well and truly keep and perform the covenants, conditions, and agreements in the manner and form and at the time agreed upon to be kept and performed as provided by said contract, and plans, drawings, and specifications, referred to in said contract, and as may be required by the changes, alterations, and modifications thereof, as provided in said contract, then the above obligation shall be void; otherwise to remain in full force and effect.

This bond is given upon the express condition that any changes, alterations, or modifications that may be hereafter ordered or made in the construction and complete installation of the work herein referred to, or the placing of an inspector or superintendent thereon by the City of Pontiac shall not operate to discharge or release the surety or sureties thereon.

IN WITNESS WHEREOF, the parties hereto have caused this instrument to be executed by their respective authorized officers this _____ day of _____ A.D. 20 _____.

Signed, Sealed and Delivered in the Presence of:

| | |
|-------|--------------|
| _____ | _____ (L.S.) |
| _____ | _____ (L.S.) |
| _____ | _____ (L.S.) |

**LABOR AND MATERIAL BOND TO THE
CITY OF PONTIAC, MICHIGAN**

KNOW ALL MEN BY THESE PRESENTS, That _____
_____ as principal, and _____

_____, as surety, are
held and firm bound unto the City of Pontiac, Michigan, a Municipal Corporation, in the
sum of:

good and lawful money of the United States of America, pursuant to Michigan State
Public Act 213 of 1963, to be paid to the City of Pontiac, Michigan, for the use and
benefit of all subcontractors, and persons, firms and corporations who shall furnish
materials, supplies and perform labor entering into the work of:

_____ Vanguard Drive Compacted Concrete Project _____

for which payment well and truly to be made, we bind ourselves, our heirs, executors,
administrators, successors and assigns, and each and every one of them jointly and
severally, firmly by these presents.

Sealed with our Seals and dated this _____ day of _____ A.D. 20_____.

WHEREAS, the above named principal has entered into a certain written contract
with the City of Pontiac, dated this _____ day of _____ A.D. 20_____,
wherein the said principal covenanted and agreed as follows, to wit:

TO COMMENCE AND COMPLETE the: _____

_____ Vanguard Drive Compacted Concrete Project _____

NOW, THEREFORE, THE CONDITION OF THIS OBLIGATION IS SUCH, that if the above named principal, legal representatives, or successors shall pay or cause to be paid to all subcontractors, persons, firms, and corporation, as the same may become due and payable, all indebtedness which may arise from said principal to a subcontractor or party performing labor or furnishing materials and supplies, or any subcontractor to any person, firm or corporation on account of any labor performed or materials and supplies furnished in connection with the contract, construction and work herein referred to, then this obligation shall be void; otherwise to remain in full force and effect.

This bond is given upon the express condition that any changes, alterations, or modifications that may be hereafter ordered or made in the construction and complete installation of the work herein referred to, or the placing of an inspector or superintendent thereon by the City of Pontiac shall not operate to discharge or release the surety or sureties thereon.

IN WITNESS WHEREOF, the parties hereto have caused this instrument to be executed by their respective authorized officers this _____ day of _____ A.D. 20 _____.

Signed, Sealed and Delivered in the Presence of:

_____(L.S.)
_____(L.S.)
_____(L.S.)

MAINTENANCE BOND

KNOW ALL MEN BY THESE PRESENTS, That _____

_____ as principal, and _____

_____, as surety, are held

and firm bound unto the City of Pontiac, Michigan, a Municipal Corporation, in the sum of:

_____ good and lawful money of the United States of America, pursuant to Michigan State Public Act 213 of 1963, to be paid to the City of Pontiac, Michigan, for the use and benefit of all subcontractors, and persons, firms and corporations who shall furnish materials, supplies and perform labor entering into the work of:

Vanguard Drive Compacted Concrete Project

_____ for which payment well and truly to be made, we bind ourselves, our heirs, executors, administrators, successors and assigns, and each and every one of them jointly and severally, firmly by these presents.

Sealed with our Seals and dated this _____ day of _____ A.D. 20 _____.

WHEREAS, the above named principal has entered into a certain written contract with the City of Pontiac, dated this _____ day of _____ A.D. 20 _____, wherein the said principal covenanted and agreed as follows, to wit:

TO COMMENCE AND COMPLETE construction of: _____

Vanguard Drive Compacted Concrete Project

NOW, THEREFORE, THE CONDITION OF THIS OBLIGATION IS SUCH, that by and under said contract, the above named principal has agreed with the City of Pontiac that for a period of ONE year(s) from the date of payment of Final Estimate, to keep in good order and repair all the work, done under said contract, excepting only such part or parts of said work as may have been disturbed without the consent or approval of the principal after the final acceptance of the work, and that whenever directed so to do by the City Engineer of the City of Pontiac by notice served in writing, either personally or by mail, on the principal at:

_____ or _____
legal representative, or successors, or on the surety at: _____

_____ WILL PROCEED at once to make such repairs as directed by said City Engineer; and in case of failure so to do within one week from the date of service of such notice, or within reasonable time not less than one week, as shall be fixed in said notice, then the City of Pontiac shall have the right to purchase such materials and employ such labor and equipment as may be necessary for the purpose, and to undertake, do and make such repairs, and charge the expense thereof to, and receive same from said principal or surety. If any repair is necessary to be made at once to protect life and property, then and in that case, the City may take immediate steps to repair or barricade such defects without notice to the contractor. In such accounting the City shall not be held to obtain the lowest figures for the doing of the work or any part thereof, but all sums actually paid therefore shall be charged to the principal or surety. In this connection the judgment of the City Engineer is final and conclusive. If the said principal for a period of ONE year(s) from the date of payment of Final Estimate, shall keep said work so constructed under said contract in good order and repair, excepting only such part or parts of said work which may have been disturbed without the consent or approval of said principal after the final acceptance of the same, and shall, whenever notice is given as hereinbefore specified, at once proceed to make repair as in said notice directed, or shall reimburse said City of Pontiac for any expense incurred by making such repairs, should the principal or their surety do so as hereinbefore specified, then the above obligation shall be void, otherwise to remain in full force and effect.

IN WITNESS WHEREOF, the parties hereto have caused this instrument to be executed by their respective authorized officers this _____ day of _____ A.D. 20 _____.

Signed, Sealed and Delivered in the Presence of:

_____ (L.S.)

_____ (L.S.)

_____ (L.S.)

GENERAL CONDITIONS

The following general conditions are agreed to as defining certain relationships which shall be taken to exist between the parties hereto and as setting forth certain conditions under which the Contract is to be fulfilled.

INDEX

Article

1. Definitions
2. Plans and Specifications
3. Shop Drawings
4. Materials and Workmanship
5. Superintendence by Contractor
6. Engineering Supervision
7. City's Right to Complete, Suspension or Termination
8. Assignment of Contract
9. Extra Work and Modification
10. Disputed Claims for Extra Compensation
11. Extension of Time
12. Liquidated Damages
13. Payment to the Contractor
14. Warranty Maintenance
15. Michigan Non-Discrimination Statute
16. Labor Laws and Ordinances
17. Patents and Patent Rights
18. Work within Railroad, Private, State or County Rights-of-way
19. Protection and Safety
20. Cleaning Up
21. Progress Schedule

GENERAL CONDITIONS

Article 1 - DEFINITIONS

- 1.1 Wherever used in the CONTRACT DOCUMENTS, the following terms shall have the meanings indicated which shall be applicable to both the singular and plural thereof:
- 1.2 ADDENDA - Written or graphic instruments issued prior to the execution of the Agreement which modify or interpret the CONTRACT DOCUMENTS by additions, deletions, clarifications or corrections.
- 1.3 BID - The offer or proposal of the BIDDER submitted on the prescribed form setting forth the prices for the WORK to be performed. (See 1.8)
- 1.4 BIDDER - Any person, firm or corporation submitting a BID for the WORK.
- 1.5 BONDS - Bid, Performance, Labor and Material, and Maintenance Bonds and other instruments of security, furnished by the CONTRACTOR and his surety in accordance with the CONTRACT DOCUMENTS.
- 1.6 CHANGE ORDER - A written order to the CONTRACTOR authorizing an addition, deletion or revision in the WORK within the general scope of the CONTRACT DOCUMENTS, or authorizing an adjustment in the CONTRACT PRICE or CONTRACT TIME.
- 1.7 CITY - The City of Pontiac, Michigan, or its properly authorized representatives; and whenever the term "City Council", "Mayor", "City Clerk", "Director of Finance", "City Engineer", or "Engineer", is used, it shall be understood to mean the Council, Mayor, Clerk, Director of Finance, or Engineer of the said City.
- 1.8 PARTICIPATION PLAN - The participation document required to accompany each proposal, as finally accepted by the City, including any revisions up to the time of acceptance.
- 1.9 CONTRACT DOCUMENTS - The Contract, including ADVERTISEMENT, INSTRUCTIONS TO BIDDERS, FORM OF PROPOSAL, BID BOND, AGREEMENT, LABOR & MATERIAL BOND, PERFORMANCE BOND, MAINTENANCE BOND, GENERAL CONDITIONS, SUPPLEMENTAL GENERAL CONDITIONS, NOTICE OF AWARD, NOTICE TO PROCEED, CHANGE ORDER, PLANS, SPECIFICATIONS, ADDENDA, and the PARTICIPATION PLAN, and any other documents specifically set forth in the Agreement.
- 1.10 CONTRACT PRICE - The total monies payable to the CONTRACTOR under the terms and conditions of the CONTRACT DOCUMENTS.

- 1.11 CONTRACT TIME - The number of calendar days stated in the CONTRACT DOCUMENTS for the completion of the WORK on each street; or the number of calendar days from the date established in the NOTICE TO PROCEED to the DATE stated in the CONTRACT DOCUMENTS for the completion of all of the WORK of the TOTAL CONTRACT; or both.
- 1.12 CONTRACTOR - The person, firm or corporation with whom the CITY has executed the Agreement, or its legal representatives.
- 1.13 ENGINEER - The City Engineer and/or the person, firm or corporation named as such in the CONTRACT DOCUMENTS.
- 1.14 FIELD ORDER - A written order effecting a change in the WORK not involving an adjustment in the CONTRACT PRICE or an extension of the CONTRACT TIME, issued by the ENGINEER to the CONTRACTOR during construction.
- 1.15 NOTICE OF AWARD - The written notice of the acceptance of the BID from the CITY to the successful BIDDER.
- 1.16 NOTICE TO PROCEED - Written communication issued by the CITY to the CONTRACTOR authorizing him to proceed with the WORK and establishing the date of commencement of the WORK.
- 1.17 OPEN TO TRAFFIC - That date as certified by the ENGINEER, when the WORK (PROJECT) or any section thereof is in a suitable condition for safe travel. The term "SUITABLE CONDITION FOR SAFE TRAVEL" shall be construed to mean that all work, INCLUDING the Leveling Course of Bituminous Material and all Concrete Work are complete. The PROJECT, or any portion thereof may be designated as "Accepted for Traffic" prior to completion of the whole project, and shall be opened to traffic as may be directed by the ENGINEER. In general, the term "OPEN TO TRAFFIC" shall be in accordance with Section 107.21 of the MDOT 2012 Standard Specifications for Construction.
- 1.18 PLANS - The part of the CONTRACT DOCUMENTS which show the characteristics and scope of the WORK to be performed and which have been prepared or approved by the ENGINEER.
- 1.19 PROJECT - The undertaking to be performed as provided in the CONTRACT DOCUMENTS.
- 1.20 RESIDENT PROJECT REPRESENTATIVE - The authorized representative of the CITY who is assigned to the PROJECT site or any part thereof.
- 1.21 SHOP DRAWINGS - All drawings, diagrams, illustrations, brochures, schedules and other

data which are prepared by the CONTRACTOR, a SUBCONTRACTOR, manufacturer, SUPPLIER or distributor, which illustrate how specific portions of the WORK shall be fabricated or installed.

- 1.22 SPECIFICATIONS - A part of the CONTRACT DOCUMENTS consisting of written descriptions of a technical nature of materials, equipment, construction systems, standards and workmanship (may include SUPPLEMENTAL SPECIFICATIONS AND/OR SPECIAL PROVISIONS).
- 1.23 SUBCONTRACTOR - An individual, firm or corporation having a direct contract with the CONTRACTOR or with any other SUBCONTRACTOR for the performance of a part of the WORK at the site.
- 1.24 SUPPLIER - Any person or organization who supplies materials or equipment for the WORK, including that fabricated to a special design, but who does not perform labor at the site.
- 1.25 WORK - All labor necessary to produce the construction required by the CONTRACT DOCUMENTS, and all materials and equipment incorporated or to be incorporated in the PROJECT.
- 1.26 WORK ORDER - A written order to the CONTRACTOR causing a change in WORK involving the authorization to undertake additional work at existing contract unit prices or at new contract unit prices for new items of work.
- 1.27 WRITTEN NOTICE - Any notice to any party of the Agreement relative to any part of this Agreement in writing and considered delivered and the service thereof completed, when posted by certified or registered mail to the said party at his last given address, or delivered in person to said party or his authorized representative on the WORK.

Article 2 - PLANS AND SPECIFICATIONS

The location of the structures and improvements which are to be built or made under this Contract, and the character, form and dimensions of their various parts, are shown in the accompanying drawings, specifications and details in the Contract Document entitled:

Vanguard Drive Compacted Concrete Project

These drawings constitute the Plans according to which the work of this Contract is to be done. Additional drawings may be prepared by the City Engineer and supplied to the Contractor during the progress of the work, as he may deem to be necessary or expedient. All such additional drawings, made in elaboration or explanation of the original drawings, are to be considered as part and parcel of the Plans and shall be respected and followed as such by the Contractor.

The Plans are supplemented and explained by a set of technical specifications, which are appended hereto, and which describe and define the quality of materials and the character of workmanship which are to enter into the work of this Contract. These are the Specifications which are referred to in Article 1, and elsewhere in this Contract. Additional specifications in further elaboration or explanation of the work to be done may be prepared by the City Engineer and supplied to the Contractor during the progress of the work, as he may deem to be necessary or expedient. Such additional specifications are to be considered as part and parcel of the specifications under this Contract, and shall be respected and followed as such by the Contractor.

Both Plans and Specifications are considered as essential parts of this Contract, and are intended to be cooperative. They shall be construed as supplementary each to the other, and any work called for in the Plans and not particularly mentioned in the Specifications, or described in the Specifications and not specially shown on the Plans, is to be regarded as included under this Contract the same as if fully set forth in the Specifications and exhibited on the Plans. Wherever figures or definite dimensions are given on the Plans or in the Specifications, these shall have precedence over dimensions taken by scaling.

In case any inconsistency, omission, or conflict shall be discovered in the Specifications or Plans, or if in any place the meaning of either or both shall be obscure or uncertain or in dispute, the City Engineer shall decide as to the true intent and his decision shall be final and binding. Any such inconsistencies, omissions, or conflict noted should be called to the attention of the Engineer, and a decision on the same obtained in advance.

Article 3 - SHOP DRAWINGS

- 3.1 The CONTRACTOR shall provide SHOP DRAWINGS as may be necessary for the prosecution of the WORK as required by the CONTRACT DOCUMENTS. The ENGINEER shall promptly review all SHOP DRAWINGS. The ENGINEER's approval of any SHOP DRAWINGS shall not release the CONTRACTOR from responsibility for deviations from the CONTRACT DOCUMENTS. The approval of any SHOP DRAWING which substantially deviates from the requirement of the CONTRACT DOCUMENTS shall be evidenced by a CHANGE ORDER.
- 3.2 When submitted for the ENGINEER'S review, SHOP DRAWINGS shall bear the CONTRACTOR'S certification that he has reviewed, checked and approved the SHOP DRAWINGS and that they are in conformance with the requirements of the CONTRACT DOCUMENTS.
- 3.3 Portions of the WORK requiring a SHOP DRAWING or sample submission shall not begin until the SHOP DRAWING or submission has been approved by the ENGINEER. A copy of each approved SHOP DRAWING and each approved sample shall be kept in good order by the CONTRACTOR at the site and shall be available to the ENGINEER.

Article 4 - MATERIALS AND WORKMANSHIP

It is mutually understood that all materials and workmanship furnished under this Contract shall be of the highest quality, to the end that a good and substantial and workmanlike job may be produced. The Contractor shall bring only first class materials to the work, and he shall furnish suitable tools and equipment and shall employ competent labor to perform the work to be done. Any materials or labor or tools or equipment that shall not, in the judgment of the Engineer, be suitable or competent to produce the desired result, may be ordered from the work by the Engineer, and such materials or labor or tools or equipment shall be promptly substituted therefor by the Contractor as will meet with the approval of the Engineer. Wherever a brand or name is given, it is for the purpose of defining or establishing a type or quality of material only.

4.1 Defective Materials

Any materials or fabricated articles furnished by the Contractor to be used in this work which shall not, in the judgment of the Engineer, be equal to the requirements of the Plans and Specifications, may be rejected by the Engineer; and such rejected materials or articles shall not be used, but shall be immediately removed by the Contractor from the site of the work.

4.2 Stored Materials

Materials and equipment distributed, stored or placed upon or near the site of the work shall be at all times so disposed as not to interfere with work being prosecuted directly by the City or by other Contractors in the City's employ or with access thereto, and not to hinder any more than may be necessary the ordinary pedestrian and vehicular traffic of the streets.

4.3 Property Rights in Surplus Materials

All excess materials excavated during the progress of the work and not required for backfilling, all timber except tree stumps cut from the right-of-way, and all other materials which have been encountered and handled during construction operations, and which constitute a disposable surplus at the end of the construction period, shall be the property of the Contractor, unless otherwise directed by the City or its Engineer. Such materials shall be hauled and neatly piled, or hauled and dumped at the places designated by the Engineer, at no extra compensation.

4.4 Water Supply

Water for construction purposes may be taken from the City mains subject to the rules of the Oakland County Water Resources Commissioner's office.

Article 5 - SUPERINTENDENCE BY CONTRACTOR

5.1 Except where the Contractor is an individual and gives his personal superintendence to the work, the Contractor shall provide a competent superintendent, satisfactory to the City and the Engineer, on the work at all times during working hours with full authority to act for the Contractor. Any orders by the Engineer given to and received by said superintendent shall be deemed to have been given to and received by the Contractor. The Contractor shall also provide an adequate staff for the proper coordination and expediting of his work. The Contractor shall maintain a complete set of plans and specifications at the site.

5.2 The Contractor may set up and establish an office on or near the site. On certain large projects, the Engineer may direct the Contractor to set up an office.

5.3 The Contractor shall lay out his own work and he shall be responsible for all work executed by him under the Contract. He shall verify all figures and elevations before proceeding with the work and will be held responsible for any error resulting from his failure to do so.

5.4 Disorderly Employees

Disorderly, intemperate, or incompetent persons must not be employed, retained, or allowed upon the work site. Any foreman or workman who refuses or neglects to comply with the directions of the Engineer in the matter of personal conduct shall, at the request of the Engineer, be promptly discharged and shall not thereafter be re-employed without the consent of the Engineer.

5.5 Relation to Other Contractors

The Contractor shall so conduct his operations as not to interfere with or injure the work of other Contractors or workmen employed by the City on adjoining or related work, and he shall promptly make good any injury or damage which may be done to such work by him or his employees or agents. Should a contract for adjoining work be awarded to another Contractor, and should the work on any one of these contracts interfere with that of the other, the Engineer shall decide which Contractor shall cease work for the time being and which shall continue or whether the work on both contracts shall continue at the same time and in what manner. In case the territory of one contract should be the necessary means of access to another contract, the Engineer shall have power to grant reasonable privileges with respect to the transportation or movement of men, animals, appliances or materials as he may adjudge to be necessary or expedient and in the best interests of the City. Any decision which the Engineer may make as to the method and time of conducting work or the use of territory shall not be made the basis of any claim for damages, but an extension of time may be claimed, if justified by the circumstances, the same as in the case of other delays caused by the acts of the

City. Any difference of opinion or conflict of interest which may arise between this Contractor and other Contractors or workmen of the City in regard to adjoining work shall be determined and adjusted by the Engineer.

5.6 Time and Sequence of Work

In general, it is the intention and understanding that the Contractor shall have control over the sequence or order of execution of the several parts of the work to be done under this Contract, and over the methods of accomplishing the required results, except as some particular sequence or method may be distinctly demanded by the Plans and Specifications or by the express provisions of this Contract; the Engineer may, however, make such reasonable requirements as may, in his judgement, be necessary for the proper and effective protection of work partially or wholly completed, and to these requirements, the Contractor shall strictly conform.

5.7 Sunday and Night Work

No Sunday work shall be done except in case of emergency or to protect from damage or injury any work that has already been done, and then only with the written consent of the Engineer, and only to such an extent as he may judge to be necessary.

Ordinarily, no night work shall be carried on which will require the presence of the Engineer or an inspector, except with the written permission of the Engineer. Night work is permissible in an emergency to the extent required to meet the emergency, but the Contractor shall notify the Engineer, as far as possible in advance, of his intentions to carry on such emergency work and of the time and place of doing it.

Article 6 - ENGINEERING SUPERVISION

The work covered by this Contract will be executed under the engineering supervision of the City Engineer, who shall have authority to inspect all materials and workmanship entering into the work, to furnish all instructions and information regarding the Plans and Specifications that may be necessary, to supply supplementary or additional plans or specifications as he may deem expedient, and to point out to the Contractor any disregard of any of the provisions of the Contract; but the right of final acceptance or condemnation of the work will not be waived at any time during its progress.

The Engineer will set suitable stakes and marks showing the locations and elevations of various parts of the work and the Contractor shall provide such labor and assistance as the said Engineer may require in setting the same. The Contractor shall take due and proper precautions for the preservation of these stakes and marks, and shall see to it that the work at all times proceeds in accordance therewith. The Engineer may provide for the inspection of any or all materials or workmanship used or intended to be used under this Contract, by assistants under his direction or otherwise, as he may deem to be advisable or expedient; but no inspection shall relieve the Contractor of his fundamental obligation to fully respect all the requirements of his Contract. Such inspection may cover any or all parts of the work, and may extend to and include the preparation or manufacture of any materials or fabricated articles intended to be incorporated in the work. The Contractor shall furnish, upon request therefor by the Engineer, such

samples for examination or testing as the Engineer may prescribe.

The Contractor shall furnish such labor and assistance as may be necessary for the proper handling of materials in all inspections and tests that may be required.

The Engineer and his duly authorized agents and employees may, at any time and for any purpose, enter upon the work and upon the premises occupied by the Contractor, and the Contractor shall provide proper and safe facilities by which the Engineer may have access to such parts of the work as may be required.

Article 7 - CITY'S RIGHT TO COMPLETE; SUSPENSION OR TERMINATION

It is agreed that the City has the right, when it shall become satisfied that the work provided for in this Contract will not be completed within the time limit, to furnish additional labor and material if necessary and render such other assistance as it may deem advisable, for the completion of said Contract, at the expense of the Contractor, and may retain the same out of the Contract price, or recover the same by legal proceedings.

It is agreed that the Mayor has the right to determine finally all questions as to proper performance of this Contract, or any part or portion thereof, and in case of improper, dilatory or imperfect performance thereof, to suspend the work at any time and to order the partial or entire reconstruction of the same, and if at any time the said Contractor shall abandon the work of this Contract or become habitually negligent of his obligations under it, or shall fail to prosecute the work with reasonable diligence, so that the time of final completion of the work shall be unnecessarily and intolerably delayed, or if he shall violate any of the provisions of the Contract, then and in such case the Mayor may declare this Contract forfeited and may, at address given in the proposal, notify him to discontinue all work under this Contract, or any part thereof, and thereupon he shall discontinue such work, or such part thereof, and shall cease to have any right to the possession of the ground; and the City shall thereupon have the right to complete the work or any part thereof by Contract or otherwise, as it may elect, and for that purpose to take possession and make use of such materials, tools, building appliances, and equipment as may be found upon the work, and to charge the expense thereof to the Contractor. Power is hereby given the Mayor to determine all such questions under this Contract, according to the true intent and meaning thereof.

All expenses charged under this provision shall be deducted and paid by the City of Pontiac out of any monies then due to the Contractor under this Contract, or any part thereof, and in such accounting the City of Pontiac shall not be held to obtain the lowest figures for the work of completing the contract, or any part thereof, or for insuring its proper completion, but all sums actually paid therefor shall be charged to the Contractor. In case the expenses to be charged are less than the sum which would have been payable under this contract if the same had been completed by the Contractor, the Contractor shall be entitled to receive the difference; and in case such expenses shall exceed the said sums, the Contractor shall pay the amount of the excess to the City of Pontiac.

Article 8 - ASSIGNMENT OF CONTRACT

It is agreed that the Contractor shall not assign or transfer this Contract, or subcontract any part of the work embraced in it, except with the written consent of the Mayor to do so.

It is further agreed that all parts of the work which may be performed by a subcontractor shall conform to the Plans and Specifications and be subject to all provisions of this Contract exactly as if performed by the Contractor and his immediate employees and workmen. No such letting of the work shall, in any way, diminish or weaken the responsibility of the Contractor for all parts of the work or lessen his obligation under this Contract.

It is likewise agreed that the Contractor shall not assign, either legally or equitably, any of the monies payable to him under this Contract, or his claim thereto, except with the written consent of the Mayor.

Article 9 - EXTRA WORK AND MODIFICATION

It is agreed that the said Contractor shall do such incidental or extra work in connection with this Contract as the Mayor may especially order in writing. If such extra work or any part thereof be of such character that it may be definitely covered by construction items for which unit prices are named in the proposal of this Contract, then and in that case the City will pay, and the Contractor will accept as full compensation for such extra work, or such part thereof, the amount computed by applying the unit prices to the quantities of extra work falling under the several items. Also, such extra work may be paid for at prices mutually agreed upon at the time by the City and the Contractor. But if such extra work, or any part thereof, be of a kind which may not be definitely covered by the regular pay items of this contract, and if no price therefor has been mutually agreed upon in advance, or if the work is of such a nature that it cannot be estimated with fair exactness in advance, then the City will pay, and the Contractor will accept as full compensation for such, an amount equal to the actual and necessary net cost in money to the Contractor for labor and materials actually used therein or expended thereon, plus fifteen percent (15%) of such net cost for superintendence, power, the use of tools, and plant, liability insurance, and all overhead and incidental expenses.

During the progress of any extra work which is to be paid for on the basis of net cost plus fifteen percent (15%), the Contractor will furnish to the City Engineer, at the end of each day, suitable time slips showing the name of and the number of hours worked by each workman employed thereon, the nature of work performed by him, and his rate of pay, together with suitable and adequate memoranda of the materials used therein, showing the character and amount of each such material, the source from which it was purchased, and the price paid or to be paid therefor.

The City may, at its discretion, furnish to the Contractor any materials or supplies or transportation required for extra work, and the Contractor shall not be entitled to any allowance or percentage on account of materials or supplies or transportation so furnished.

It is agreed that all extra work that may be ordered and performed under the provisions of this article shall be done by the Contractor in an effective and workmanlike manner, and shall be subject to the same restrictions and liabilities as those which apply to the general work of this Contract; and the Contractor will be responsible for the maintenance and protection of such extra work until the time of the final acceptance of the entire job by the City.

And it is further agreed that no claim against the City on account of extra work shall be valid unless such extra work has been previously ordered in writing by the Mayor, and unless such claim has been presented for payment as soon as practicable after the completion of such extra work and before the

making up of the final estimate.

When it becomes necessary in the prosecution of any work or improvement under contract to make minor alterations or modifications of such contract or the plans and specifications thereof, such alterations, changes or modifications shall be made only on the written order of the Mayor.

No such order shall be made until the price to be paid for the work or material or both and the credits, if any, to be allowed by the City under the altered and modified Contract shall have been agreed upon in writing and signed by the Contractor and by the Mayor.

Article 10 - DISPUTED CLAIMS FOR EXTRA COMPENSATION

If any inconsistency, omission, or conflict is discovered in either the plans or the specifications, or if in any place the meaning of either the plans or the specifications, or both, is obscure, or uncertain, or in dispute, the Engineer will decide as to the true intent.

In case the Contractor deems extra compensation is due for work or materials not clearly covered in the contract, or not ordered by the Engineer as extra work, or due to changed or altered conditions, the Contractor shall notify the Engineer in writing of the Contractor's intention to make claim for such extra compensation before beginning work on which the Contractor intends to base a claim and shall afford the Engineer every facility for keeping actual cost of the work. The Contractor and the Engineer shall compare records and bring them into agreement at the end of each day. Failure on the part of the Contractor to give such notification or to afford the Engineer proper facilities for keeping strict account of actual cost will constitute a waiver of the claim for such extra compensation except that consideration will be given to claims to the extent that they are substantiated by City records. The determination of extra compensation made by the City, where the Contractor has failed to give proper notice of his claim for extra compensation as provided herein or has failed to afford the Engineer proper facilities for keeping strict account of actual costs, shall be final and binding on the Contractor. The filing of such notice by the Contractor and the monitoring of cost by the Engineer for said notice of claim, shall not in any way be construed to establish the validity of the claim. When the extra work in question has been completed, the Contractor shall file the claim for extra compensation with the Engineer.

Such claims shall be filed with the Engineer in a timely manner but no later than 10 days after the contract is completed. A written decision will be given to the Contractor in a timely manner, regarding the approval, partial approval, or disapproval of the Contractor's claim for extra compensation. The City will determine procedures for reviewing the Contractor's claim.

Article 11 - EXTENSION OF TIME

It is agreed that if the Contractor shall be unavoidably delayed in beginning or fulfilling this Contract by reason of excessive storms or floods, or by acts of Providence, or by general strikes, or by court, injunction, or by stopping of the work by the City because of any emergency or public necessity, or by reason of extra work ordered by the City Engineer, or by any act, neglect, delay, or default on the part of the City, the Contractor shall have no valid claim for damages on account of any such cause or delay, but he shall be, in such case, entitled to such extensions or advancement of the time period specified in the Agreement as the City Engineer shall adjudge to be just and reasonable; provided, however, that

formal claim for such extension shall be made in writing by the Contractor within a week after the date upon which such alleged cause of delay shall have occurred. The closing down of the work during the winter season on account of cold weather shall not be taken as entitling the Contractor to any extension of time within the meaning of this Article.

In case the Contractor shall be delayed in the fulfillment of his obligations under this Contract, from any cause whatsoever, and in case the City shall acquiesce in the Contractor's prosecution and completion of the work, or any part of it, after the date at which it should have been finished, such acquiescence shall not operate as a waiver of any of the City's rights under this Contract, nor shall it invalidate or in any way weaken the Contractor's bonds.

Article 12 - LIQUIDATED DAMAGES

It is expressly covenanted and agreed by and between the parties hereto that time is and shall be considered as of the essence of the Contract, and in the event that said Contractor shall fail in the due performance of the entire work to be performed under this Contract, by and at the time herein mentioned and referred to in the Agreement, or within some other certain date subsequent to this to which the time limit for completion of the work may have been advanced under provisions of Article 11, the said Contractor shall pay unto the City as and for liquidated damages, and not as a penalty, the sum of **one thousand dollars (\$ 1,000.00)** for each and every calendar day that the said Contractor shall be in default.

Said sum of **one thousand dollars (\$ 1,000.00)** per day, in view of the difficulty of estimating such damages with exactness, is agreed upon as the damages which will be suffered by the City by reason of such default. It is also understood and agreed by the parties to this Contract that the liquidated damages hereinbefore mentioned are in lieu of the actual damages arising from such breach of this Contract; which said sum the City shall have the right to deduct from any monies in its possession, otherwise due, or to become due to said Contractor, or to sue for and recover compensation for damages for non-performance of this Contract at the time stipulated herein and provided for. (See also any Special Provisions for Liquidated Damages.)

Said liquidated damages are in addition to any actual damages which the City may recover under the provisions of the contract.

Article 13 - PAYMENTS TO THE CONTRACTOR

13.1 Contractor's Obligation Prior to Payment

It is agreed that before the Contractor shall demand partial or final estimates or payments, the City may require him to furnish the City satisfactory evidence that all persons that have supplied labor or materials for the work embraced under this Contract have been fully paid for the same; and that in case such evidence be not furnished as aforesaid, such sums as the City may deem necessary to meet the lawful claims of the persons aforesaid be retained by the City from any monies that may be due or become due to him under this Contract until such liabilities shall be fully discharged and evidence thereof be furnished to the City. The Contractor agrees to make prompt settlement for all repair expenses made by the City as a

result of the Contractor's work. Consent of the Contractor's surety will be required prior to final payment.

13.2 City's Obligation to Pay

It is agreed that, in consideration of the faithful and entire performance by the Contractor of his obligations under this Contract, the City shall pay to him, at the times and in the manner stipulated, the total sum as determined by calculations from the unit prices in the proposal, but diminished by such amount as the City may lawfully retain as liquidated damages under the provisions of Article 12 herein; and the Contractor shall accept the payment of such sum as full compensation for his work under this Contract.

13.3 Progress Estimates and Payments

Progress payments shall comply with Act No. 524 Public Acts of 1980. At about the first of each month, during which satisfactory progress has been made toward the final completion of the work, the Engineer will make up an estimate of the amount and value of the work which has been done under this Contract since the date of the last preceding estimate and will report such estimate in writing to the City Director of Finance. Such estimates shall not be required to be made by strict measurements, or with exactness, but may be made either wholly or in part by appraisement or estimation or by a consideration of accounts for labor and materials, and it shall be sufficient if it is approximate only. Any error or inaccuracy which may occur in any progress estimate may be allowed for or corrected in any subsequent estimate.

Following the rendering of such estimate by the Engineer, and as soon as practicable thereafter, the City will pay to the Contractor on account a sum equal to ninety percent (90%) of the Contract price of such work. The remaining ten percent (10%) will be retained until work is fifty percent (50%) in place. After the work is fifty percent (50%) in place, additional retainage shall not be withheld unless the City determines that the Contractor is not making satisfactory progress, or for other specific cause relating to the Contractor's performance under the Contract. If the City so determines, the City may retain not more than ten percent (10%) of the dollar value of work more than fifty percent (50%) in place.

The Director of Finance may require the Contractor, before the payment of any estimate, to file an affidavit showing the unpaid bills for materials or supplies of any kind furnished for this work. Any time after 94% of the work is in place, the Contractor may request release of all of the retainage. The City shall be required to release the retainage plus interest to the Contractor in such case only if the Contractor provides to the City an irrevocable letter of credit in the amount of the retainage plus interest, issued by a bank authorized to do business in this State, and containing terms mutually acceptable to the Contractor and the City. The progress estimates and payments thus provided for will include all extra work which may be done under the provisions of this Contract on the same basis as other work is included, all such extra work being regarded herein as essentially a part of this Contract, and not merely supplementary to it.

Disputes under this provision may be submitted to the decision of an agent, at the option of the City, pursuant to Section 4 of Act 524 of 1980. (MCLA 125.1564).

13.4 Measurement

Due and proper measurements will be taken by the Engineer during the progress of the work, and his estimates, based upon such measurements, shall be final and conclusive evidence of the amount of work performed under this Contract.

13.5 Final Estimate and Payment

As soon as practicable after the satisfactory completion of all the work included under this Contract, the Engineer will make final inspection of all the work and will make up a final estimate of the amount due to the Contractor under the terms of this Contract. At this time the Contractor shall file with the Director of Finance an affidavit stating that all bills have been paid in full for all materials, supplies and labor of every kind that have been furnished for this work, or stating the balance due for such materials, supplies and labor (See sample on Page 52). The Contractor shall file with the City Engineer the Contractor's Declaration found on Page 51, stating that all claims for extra payments have been satisfactorily settled and there will be no further claims. A final certificate relative to compliance of Affirmative Action Plan also will be required as a condition of payment. Consent of the Contractor's surety shall also be filed. The Engineer will then certify this estimate to the City Director of Finance and the Contractor will be paid the amount of said estimate, less the amounts previously paid; excepting that the City may, at its option, reserve such amount as it may deem necessary to meet the undischarged obligations of the Contractor for materials or labor expended upon this work until such obligation shall have been paid.

Article 14 - WARRANTY MAINTENANCE

If, at any time during a one-year period from the date of payment of the final estimate, the need of any repair or replacement becomes apparent, the City will at once notify the Contractor in writing, either personally or by mail at the address given in the proposal; and if within one week after such notification the Contractor has not made the necessary repairs, the City may proceed to do the required work and to charge the cost thereof against the Contractor, excepting that in the case of a repair necessary to be made at once to protect life and property, then and in that case the City may take immediate steps to repair or barricade such defects without notice to the Contractor.

Following the performance of any such repair work by the City, and as soon as practicable thereafter, an itemized statement of the cost of such work will be sent to the Contractor by the City. In such accounting the City shall not be held to obtain the lowest figures for the doing of the work or any part thereof, but all sums actually paid therefor shall be charged to the Contractor.

Article 15 - MICHIGAN NON-DISCRIMINATION STATUTE

It is agreed that the Contractor and his subcontractors will not discriminate against an employee or applicant for employment with respect to hire, tenure, terms, conditions or privileges of employment, or a matter directly or indirectly related to employment, because of race, color, religion, national origin,

age, sex, height, weight, or marital status; or because of a handicap that is unrelated to the individual's ability to perform the duties of a particular job or position. Breach of this covenant may be regarded as a material breach of the Contract.

Article 16 - LABOR LAWS AND ORDINANCES

The Contractor shall obey and abide by all laws of the State of Michigan relating to the employment of labor on public work, and all the charter provisions and ordinances of the City of Pontiac regulating or in respect to public improvements.

Article 17 - PATENTS, PATENT RIGHTS, AND TRADEMARKS

The Contractor shall indemnify, protect, defend and save the City of Pontiac, including all elected and appointed officials, all employees and volunteers, all boards, commissions and/or authorities and their board members, employees, volunteers and others working on behalf of the City, harmless against all claims or actions brought against the City by reason of any actual or alleged infringement upon patent, trademark or service mark right in any article, material, process, machine or appliance used by him in this work.

Article 18 - WORK WITHIN RAILROAD, PRIVATE, STATE OR COUNTY RIGHTS-OF-WAY

All construction work within railroad, private, State or County highway rights-of-way shall be performed by the Contractor in accordance with the requirements of the rights-of-way agreement and of the railroad or highway department having jurisdiction; including procedures of excavating, backfilling, removing and replacing pavement, maintaining and safeguarding traffic, inspection procedures of jacking pipes and encasing pipes under railroads and highways, etc. All required construction permits and surety bonds shall be furnished by the Contractor before commencing work. At the conclusion of the work, the Contractor shall furnish a written statement from the railroads and highway departments that work in rights-of-way under their jurisdiction has been completed to their satisfaction.

Article 19 - PROTECTION AND SAFETY

19.1 Protection Against Accident

The Contractor shall put up and shall maintain during the continuance of the work such barriers, lights and other protective devices and watchmen, when necessary, as will effectively prevent any accident in consequence of his work, and he shall be liable for all accidents and damages occasioned in any way by his acts or neglect, or by the acts or neglect of his agents, employees, or workmen.

19.2 Responsibility for Damage to Work

The Contractor shall assume full responsibility for loss or damage to the work during the entire construction period resulting from caving earth and from storms, floods, frosts, and other adverse weather conditions, and from all other causes whatsoever not directly due to the acts or neglect of the City, and shall turn the finished work over to the City in good

condition and repair at the time of the final estimate. This responsibility of the Contractor shall cover all these elements included as extra work under this Contract in exactly the same manner as the regular work is covered.

19.3 Responsibility for Adjoining Structures

The Contractor shall have full responsibility for the protection of all property, driveways, buildings, fences, and other structures, and their foundations, along (or near) the line of the work, and shall indemnify, defend and save harmless the City of Pontiac, including all elected and appointed officials, all employees and volunteers, all boards, commissions and/or authorities and their board members, employees, volunteers and others working on behalf of the City, against all damages or alleged damages to any such structure arising out of his work.

No driveway shall be entirely closed to travel, even temporarily, except with the written consent of the Engineer, previously obtained. Highways must be suitably posted during the period in which construction work is in progress in them, and the Contractor shall be responsible for this precaution. Suitable bridges must be built across trenches at highway crossings to facilitate travel, and this same requirement shall apply likewise to private roadways.

19.4 Responsibility for Water Courses

The Contractor shall maintain in continuous and effective service all drains and water courses touched during the progress of the work. If it should become necessary, temporarily, to divert or obstruct the flow of any such water course or drain, written consent must first be obtained from the Engineer, and the Contractor shall assume full responsibility for the consequences.

19.5 Responsibility for Utilities

Certain underground structures and utilities have been shown as an aid to the Contractor, but the City does not guarantee their location or that other underground structures or utilities may not be encountered. It shall be the responsibility of the Contractor to make all arrangements with the owners of the respective utilities for the establishment of their location, prior to beginning the construction.

The Contractor shall assume full responsibility for the protection of all utilities, water, sewer, gas, telephone, or any other, either public or private, along or near the line of work, and will be held responsible for any damages to such utilities arising from his operations. If for the Contractor's convenience he desires that any portion of the utilities be moved to facilitate his operations, he shall make all necessary arrangements with the owner of the respective utilities, and pay all costs resulting from this work.

In cases where utilities, water, sewer, gas, telephone or any other, either public or private, are directly in the line of the structures being constructed, such as those being within the

permissible limits of a sewer excavation or pavement excavation, and the City deems it necessary that the said utility be moved, the said company or companies, agents or superintendents will be notified by the City Engineer to remove the same within a specified time. The Contractor shall not interfere with said utility or any portion thereof until the expiration of the time specified in said notice. The Contractor will not be held responsible for any costs resulting from this work.

In all cases where there is a dispute between the Contractor and the owner of the respective utility as to necessity of moving or repairing same within City-owned right of way, the City Engineer shall make the final decision in the matter, which decision shall be binding on the respective parties, and order the respective parties to proceed accordingly.

19.6 Protection of Trees and Shrubbery

The Contractor shall take ample precautions to protect all trees and ornamental shrubbery from injury by workmen, teams, or other agencies connected with his work. Such trees or shrubbery shall be surrounded by protective posts or fencing before construction work begins if, in the judgment of the Engineer, such precautions are necessary.

19.7 Protection of Reference Points

The Contractor shall carefully preserve monuments, bench marks, reference points and stakes and, in case of willful or careless destruction, he shall be charged with the resulting expense and shall be responsible for any mistakes that may be caused by their unnecessary loss or disturbance.

19.8 Removal of Water

The Contractor shall provide all necessary pumps, pipes, drains, ditches, dikes, and other means for adequately protecting the work from damage by water, and he shall so protect it during the entire construction period. No direct payment will be made to the Contractor for removing or pumping water, or for any of the means employed in protecting the work against damage by water, but compensation therefor shall be considered as being included in the unit prices fixed in this Contract for the several structures.

Water pumped or delivered from trenches and excavations shall be disposed of in such manner as will not injure the public health, nor damage public or private property, nor injure any work complete or in progress.

19.9 Dust Control

The Contractor shall apply water or dust palliative, or both, for the alleviation or prevention of dust nuisance caused by his operations. Dust control operations shall be performed by the Contractor at the time ordered by the Engineer, but failure of the Engineer to issue such order will not relieve the Contractor of his responsibility.

Such dust control materials shall be applied as often as is necessary to control the dust. The use of road oils and waste oils to control dust is prohibited unless authorized by the Engineer.

No direct payment will be made for any such work performed or material used to control dust under this Contract.

19.10 Control of Noise

The Contractor shall eliminate noise to as great an extent as possible at all times. Air compressors shall be equipped with silencers, and the exhaust of all gasoline motors and other power equipment shall be provided with mufflers. In the vicinity of hospitals, libraries and schools, special precautions shall be taken to avoid noise and other nuisance, and the Contractor shall require strict observances of all pertinent ordinances and regulations. Any blasting permitted in such locations shall be done with reduced charges.

19.11 Erosion Control

The Contractor shall comply with the Soil Erosion and Sedimentation Control Act, Act 347 of 1972, as amended by Act 197, Public Acts of 1974 and local City or County soil erosion control programs. Also, should the local agency determine that the construction operation is in violation of the act and cites the City, the Contractor shall take immediate action, as directed by the City, to insure compliance with the Act.

19.12 First Aid

The Contractor shall at all times provide a satisfactory first aid kit at the job site. Emergency phone numbers for police, doctors, and emergency vehicles shall also be kept in the first aid kit.

19.13 Ventilation and Safety in Gas

Positive and approved means shall be provided by the Contractor for the detection of gas in existing sewers. If gas is encountered and cannot be removed by natural ventilation, then ventilating equipment of sufficient capacity and suitable type to adequately and quickly dilute the gas shall be promptly installed and operated. In all work where gas is present, no flame or other open light shall be used on the work. The Contractor shall be required to enforce a "no smoking" ban on all workmen present.

19.14 Sanitary Regulations

The Contractor shall provide for his employees an abundant and convenient supply of drinking water, taken from the City mains or from some other safe and wholesome source, and shall give orders against the use for drinking purposes of any other water in the neighborhood known to be prejudicial to the health of the workers.

The Contractor shall provide at convenient points, properly secluded from observation, a

sufficient number of sanitary conveniences, and shall maintain them strictly without nuisance and without offense to the public or to residents in the vicinity of the work. The number, location, character and conditions of maintenance of these utilities must at all times be such as will meet the approval of the Engineer.

Article 20 - CLEANING UP

Upon completion of the actual work of construction, the Contractor shall clean up and leave in neat condition all the premises which he has occupied during the construction period. Before the time of the final estimate, the Contractor shall remove from the premises all surplus excavation, debris, and rubbish, and all unused materials, together with all tools and equipment, or shall deposit them at such points and in such manner as the Engineer may require.

Before leaving the grounds, he shall replace or put in good repair all fences, telephone poles and lines, roadways, and other property that may have been damaged by him during the progress of the work. Damage to crops within the limits of the right-of-way or street will be paid by the City, but the Contractor must assume responsibility for all damages outside of this right-of-way.

Article 21 - PROGRESS SCHEDULE

The CONTRACTOR shall submit a Progress Schedule to the City for review and approval within ten (10) days of receipt of the "NOTICE OF AWARD". The Contractor shall address the following items in the proposed progress schedule.

- 21.1 Start date and completion date for **Stage 1**.
- 21.2 Start date and completion date for **Stage 2**.
- 21.3 Start date and completion date for **Stage 3 or Stage 3a**.
- 21.4 Anticipated date for **Approved for Traffic**.
- 21.5 Anticipated date for **Substantial Completion**.
- 21.6 Final completion date.

CONTRACTOR'S DECLARATION

I hereby declare that I have not, during the period of _____
to _____ A.D., 20 _____, performed any work, furnished any
material, sustained any loss, damage or delay for any reason, including soil conditions encountered or
created, or otherwise done anything for which I shall ask, demand, sue for, or claim compensation from
the City of Pontiac or his agents, in addition to the regular items set forth in the contract named or
numbered **Vanguard Drive Compacted Concrete Project** and dated _____
_____ A.D., 20 _____, for _____

executed between myself and the City of Pontiac, and in the Change Orders for work issued by the City
in writing as provided thereunder, except as I hereby make claim for additional compensation and/or
extension of time as set forth on the itemized statement attached hereto.

There (is) (is not) an itemized statement attached.

Date: _____

By: _____

Title: _____

CONTRACTOR'S AFFIDAVIT

STATE OF MICHIGAN)
)SS
COUNTY OF)

The undersigned _____, hereby represents that on _____, he (it) was awarded a contract by the City of Pontiac, hereinafter called the Owner, to _____

in accordance with the terms and conditions of Contract **Vanguard Drive Compacted Concrete Project** and the undersigned further represents that the subject work has now been accomplished and the said contract has now been completed.

The undersigned hereby warrants and certifies that all of his (its) indebtedness arising by reason of the said contract has been fully paid or satisfactorily secured; and that all claims from subcontractors and others for labor and material used in accomplishing the said project, as well as all other claims arising from the performance of the said contract, have been fully paid or satisfactorily settled. The undersigned further agrees that, if any such claim should hereafter arise he (it) shall assume responsibility for the same immediately upon request to do so by the Owner.

The undersigned, for a valuable consideration, the receipt of which is hereby acknowledged, does further hereby waive, release and relinquish any and all claims or right of lien which the undersigned now has or may hereafter acquire upon the subject premises for labor and material used in accomplishing said project owned by the Owner.

This affidavit is freely and voluntarily given with full knowledge of the facts, on this _____ day of _____ A.D. 20 _____.

Contractor: _____

By: _____

Title: _____

Subscribed and sworn and to before me, a Notary Public in and for _____ County, Michigan, on this _____ day of _____ A.D. 20 _____.

Notary Public
My Commission expires: _____

VANGUARD DRIVE
COMPACTED CONCRETE PAVEMENT

TABLE OF CONTENTS

NOTICE TO BIDDERS

SPECIFICATIONS AND SPECIAL PROVISIONS

MDOT Specification Reference53
Progress Clause54-56
Utility Coordination57-59
Project Coordination.....60
Permits and Inspection Fees61-62
Maintaining Traffic63-73
Pavement Cores74-80
Project Cleanup81
Geotextile Fabric82-83
Underdrains84
Compacted Concrete Pavement85-93
Temporary Construction Work Zone Signs and Barricades.....94
Reconstruction Sprinkler Systems95-96

CITY OF PONTIAC
NOTICE TO BIDDERS
FOR
MDOT SPECIFICATION REFERENCES

HRC

Page 1 of 1

5/21/2021

Specifications and Contract Pay Items

Construction of this project shall be in accordance with the Michigan Department of Transportation 2012 Standard Specifications for Construction except as noted in the special provisions, specifications and conditions.

All contract pay items found in the proposal shall be constructed based on the Michigan Department of Transportation 2012 Standard Specifications for Construction. This shall apply at all times, unless the pay item is designated with a "Special". If this designation is present, there has been a special provision written for that pay item. This special provision can be found in the contract specification book under the section "Special Provisions".

Frequently Used Special Provisions, Notice to Bidders and Supplemental Specifications

All references to the "Department" in the Michigan Department of Transportation 'Notice to Bidders', 'Frequently Used Special Provisions' and 'Supplemental Specifications', which are referenced in these specifications, shall indicate a reference to the City of Pontiac.

CITY OF PONTIAC
PROGRESS CLAUSE

HRC

Page 1 of 3

Date: 5/27/2021

a. General

Submit a complete, detailed and signed, Progress Schedule, to the Engineer. The Engineer for this project is as follows:

Abdul H. Siddiqui, P.E., City Engineer
City of Pontiac
47450 Woodward Avenue
Pontiac, Michigan 48342
ASiddiqui@pontiac.mi.us

The Progress Schedule shall include, as a minimum, the controlling work items for the completion of the project and the planned dates (or work days for a work day project) that these work items will be controlling operations. When specified in the bidding proposal, the date the project is to be opened to traffic as well as the final project completion date shall also be included in the project schedule. If the Bidding Proposal specifies other controlling dates, these shall also be included in the Progress Schedule.

After receiving Notice of Award, start work on the date agreed upon with the Engineer, which date shall be no earlier than **August 2, 2021, unless the City agrees to a revised start date.** In no case, shall any work be commenced prior to receipt of formal notice of award by the Department and acceptance of progress schedule.

After award and prior to the start of work, the Contractor must attend a preconstruction meeting with the Engineer. The schedule for this meeting will be determined by the Engineer after submittal of Progress Schedule to the Engineer. The Engineer will arrange the day, time and place for the preconstruction meeting. The meeting will be conducted after project award and may be rescheduled if there are delays in the award of the project.

The named subcontractor(s) for designated and/or Specialty Items (if such items are designated in the proposal), which materially affect the work schedule, shall also be present at the scheduled meeting. The meeting will be conducted after project award and may be rescheduled if there are delays in the award of the project.

No extensions of time will be allowed for increases in contract quantities or extra work, until it can be shown that such increases or extras affect the critical item of work.

No extension of time will be granted for labor disputes, unless it can be shown that such disputes are industry wide and that the delay affects the critical item of work.

No extension of time will be granted as a result of work stoppages ordered by the City for Contractor non-compliance.

No extension of time will be granted for delays in delivery of critical materials, unless the delay can be shown to be industry wide and the delay affects the critical item of work.

The Contractor shall be expected to mobilize sufficient labor and equipment to complete the project within the specified time frames.

The Contractor shall attend regular bi-weekly construction progress meetings throughout the duration of construction and shall provide updates to the Engineer that shall include work completed to date, a two-week outlook for upcoming work, and any necessary updates regarding the Milestone dates identified herein.

The Contractor may be required to meet with City representatives for a post-construction review meeting, as directed by the Engineer. The Engineer will schedule the meeting.

The Contractor must comply with all local ordinances (noise, etc.) as described in the Special Provision for Maintaining Traffic

b. Milestones

1. Approved for traffic

The project shall be sufficiently complete and in suitable condition to be designated "Approved for Traffic" and shall be Opened to Traffic as directed by the Engineer. The project has two options for final paving operations as shown on the Maintenance of Traffic (MOT) Staging plan sheets and as follows:

Option 1 (MOT Stage 3): Paving during Labor Day Week – Approved for Traffic **September 7, 2021 before 12 a.m.**

Option 2 (MOT Stage 3A): Half width paving operation, multiple days during the week – Approved for traffic no later than **September 12, 2021 before 12 a.m.**

The "Approved for Traffic" condition shall be as defined in section 107.21, Approved for Traffic, of the MDOT 2012 Standard Specifications for Construction

2. Substantial Completion

Other than the delayed acceptance requirements for Turf Establishment, the entire project including punch list items and placement of permanent soil erosion control items (if required as part of the project) shall be completed within **60 calendar days from start of construction or by September 30, 2021, whichever is sooner**. Punch list items shall be completed within 3 weeks of procurement by the Engineer.

3. Entire Project Including Delayed Acceptance Items

All contract work shall be complete, including delayed acceptance requirements for Turf Establishment on or before **May 27, 2022**.

c. Liquidated damages for failure to meet milestones

Failure on the part of the Contractor to meet each of the above milestones by the date specified shall result in the assessment of Liquidated Damages against the Contractor as provided in Section 108.10, Liquidated Damages, of the MDOT 2012 Standard Specifications for Construction.

Liquidated Damages will continue to be assessed for each calendar day or portion of a day that this work remains incomplete even if these days extend beyond the normal seasonal shutdown date of **November 15, 2021**.

Assessment of Liquidated Damages and/or contract adjustments applies to hourly/daily restrictions included in the Maintaining Traffic Special Provision.

d. Workday, hour, and other work restrictions imposed by local communities

The work hours described may be modified or changed by the Engineer due to Holidays, Special Events, or Traffic Volumes.

- A. Contractor's operations shall be limited by local municipality work time, noise, and dust ordinance unless approved by the local municipality and the Engineer in writing.
 - Typical working hours for the City of Pontiac are 7 a.m. to 7 p.m. Monday through Saturday. Work on Sunday and during a holiday must be requested and approved in advance by the City.
- B. No work or lane closures, unless approved by the Engineer, shall be performed during:
2021: Memorial Day (from 3:00 pm Friday, May 28th – 6:00 am Tuesday, June 1st), 4th of July (from 3:00 pm Friday, July 2nd – 6:00 am Monday, July 5th) or Labor Day (from 3:00 pm Friday Sept 3rd – 6:00 am Tuesday, September 7th).

CITY OF PONTIAC
 NOTICE TO BIDDERS
 UTILITY COORDINATION

HRC

Page 1 of 3

Date: 5/28/2021

a. General

The Contractor shall cooperate and coordinate construction activities with the owners of utilities as stated in Section 104.08, Cooperation by the Contractor, of the Michigan Department of Transportation 2012 Standard Specifications for Construction. In addition, for the protection of underground utilities, the Contractor shall follow the requirements in Section 107.12, Contractor's Responsibility for Utility Property, and Services. Contractor delay claims, resulting from a utility, will be determined based upon Section 109.05, Payment for Contract Revisions and Section 108.09, Request For Time Extensions On Work Day, Calendar Day, and Calendar Date Contracts.

The location of all public utilities shown on these plans is taken from the best available data. The City of Pontiac will not be responsible for any omission or variations from the locations shown. Pursuant to Public Act 174 of 2013 as a condition of this contract notice shall be given to MISS DIG prior to underground work to be performed in accordance with this contract. Phone (800) 482-7171, (248) 647-7344, or 811.

b. Public Utilities

The Special Notes/General Notes in the plans and below show a list of utility companies that have facilities located within the Right-of-Way.

| | |
|--|--|
| <p>AT&T Steve Ruatto 54 N. Mill St P.O. Box 32 Pontiac, Michigan 48342 P: 248.972.0140 E: sr4579@att.com Emergencies: 1-800-515-7272</p> | <p>Consumers Energy Ernest Martyniuk 14500 Dixie Hwy Holly, Michigan 48442 O: 248.433.5868 C: 586.770.6688 Ernest.Martyniuk@cmsenergy.com Emergency: 1-800-477-5050</p> |
| <p>OCWRC Water Zach Earp 1 Public Works Drive, Bldg 95W Waterford, Michigan 48328 P: 248.858.7365 earpz@oakgov.com</p> | <p>OCWRC Sanitary Rick Devisch 1 Public Works Drive, Bldg 95W Waterford, Michigan 48328 P: 248.858.4939 devischr@oakgov.com</p> |
| <p>Storm Sewer & Street Lighting City of Pontiac Abdul Siddiqui, City Engineer 47450 Woodward Avenue Pontiac, Michigan 48342 P: 248.758.3600 asiddiqui@pontiac.mi.us</p> | <p>DTE Energy Carl Ford 37849 Interchange Drive Farmington Hills, Michigan 48335 P: 248.427.2937 Carl.Ford@DTEEnergy.com Emergency: 1-800-477-4747</p> |

| | |
|--|--|
| <p>Traffic Signals Michigan Department of Transportation Jim Kwapiszewski P: 517.242-1486 kwapiszewskij@michigan.gov</p> | |
|--|--|

The owners of existing service facilities that are within grading or structure limits will move them to locations designated by the Engineer or will remove them entirely from the highway Right-of-Way. Utilities may be relocating or replacing facilities that may not be shown on the plans in conjunction with the proposed roadwork.

Owners of Public Utilities will not be required by the City of Pontiac to move additional poles or structures in order to facilitate the operation of construction equipment unless it is determined by the Engineer that such poles or structures constitute a hazard to the public or are extraordinarily dangerous to the Contractor's operations.

c. Known Utility Conflicts:

A utility conflict is where a road or storm sewer structure shares the same space as the utility and cannot be built unless the utility relocates. The contractor shall verify existing utilities in areas of underground work, including the signal foundations. Field adjustments may be required as directed after MISS DIG has staked the locations. See plans for utility contact information.

d. Coordination:

AT&T: Based on information received from our miss dig ticket ATT has a buried conduit along the ROW of Telegraph Road and another buried conduit toward the P.O.E. of the project that crosses Vanguard Drive. The exact locations and/or depths for these lines are unknown but historically ATT conduits are placed between 30 to 42 inches from the existing ground. Based on the provided information and scope of work for this project there are no known conflicts with any AT&T facilities.

Consumers Energy has a gas main that is along the south side of Vanguard Drive behind the existing curb and gutter ranging from 3 to 7 feet from the back of the curb. A 4-inch gas main enters the project limits along the eastern side of the southern property's parking lot area running north and south and then turns east where it is reduced to a 2-inch plastic medium pressure gas main. Based on the information received from the facility owner there are no known gas main lead crossings within the projects, therefore no known utility conflicts with Consumers Energy.

DTE Electric has underground facilities along the southern side of the project that traverse in and out of ground placed transformers which appear do not create any utility conflicts with the road construction. Let it be known that DTE facility maps do show street lighting along Vanguard Drive on the facility map but it appears the energizing line crosses overhead to power the lights. Therefore, no known electrical conflicts with DTE Energy facilities

OCWRC has a 12-inch water main that enters the project limits starting at the eastern side of the southern property and then crosses Vanguard Drive north and south. This water main appears to be located very close to the same location as the gas main. The 12-inch water main

then continues east along the northern side of Vanguard Drive approximately 8 feet behind the existing curb and gutter. Based on this information it is our opinion that there are no conflicts with the county's water main pipe.

OCWRC has no existing sanitary structures located within the project limits in accordance with WRC's most current CCTV scoring map received from their engineer. All existing sanitary within the area appears to be east and south of the proposed project limits. Therefore there are no conflicts with the existing sanitary sewer system.

CITY OF PONTIAC

NOTICE TO BIDDERS

PROJECT COORDINATION

HRC

Page 1 of 1

5/27/2021

The Contractor is hereby notified that there may be other construction projects, not associated with this project, scheduled for construction during the same timeframe as this project within the local vicinity.

The follow is a listing of known construction projects within the local vicinity that may have an impact on this project. Please note that this listing may not be complete, and the Contractor shall verify any other projects within the local vicinity that may impact this project.

- Telegraph Road between Orchard Lake Road and Elizabeth Lake Road – MDOT
- No other projects or special events known to be taking place during this time in the area.

The Contractor shall coordinate its work on this project with that by the Contractor on other projects, as directed by the Engineer. No additional compensation will be allowed for costs incurred by the Contractor due to coordinating with or delays caused by other projects.

CITY OF PONTIAC
SPECIAL PROVISION
FOR
PERMITS AND INSPECTION FEES

HRC

Page 1 of 2

Date: 5/27/2021

a. Description

The Contractor shall observe and follow all permit(s) required for project construction in accordance with Section 107.02, Permits and Licenses, of the 2012 Standard Specifications for Construction. The City of Pontiac (Owner) has applied for the following permit(s) which shall be obtained by the Contractor.

In addition, the Contractor shall adhere to the specifications in this proposal and details included in the plans, as required by the permit(s).

b. Materials

All work must be in accordance with the contract documents.

c. Construction

Refer to Table 1 on next page.

d. Measurement and Payment

Permit and inspection fees assessed by the respective agencies from Table 1 shall be paid for by the contractor if there is any associated fee.

| Pay Item | Pay Unit |
|------------------------------|-----------------|
| Reimbursed Permit Fees | Dollar |

*There is **No Fee** for the required MDOT permit for this project from Table 1. Reimbursed Permit Fees is not included as part of this project as a result.*

Bond(s) and insurance requirements to fulfill permit conditions to the governmental agencies and/or permit issuer will not be paid for separately but considered in other contract pay items.

Table 1: Permits and Fees

| Further action required by Contractor | Reference Number | Issuing Agency | Permit and Work Type | Bond | Insurance | Fees | Notes |
|---------------------------------------|------------------|----------------|--|------|-----------|--------|--|
| See Permit | 77308 | MDOT | Right-of-Way Permit for Construction Signing | | | No Fee | |
| See Permit | 77308 | MDOT | Traffic Signal Staging | | | No Fee | Coordinate with Jim Kwapiszewski 517-242-1486 |
| See Permit | 77308 | MDOT | Temporary Lane Closure | | | No Fee | |

CITY OF PONTIAC

MAINTAINING TRAFFIC

HRC

Page 1 of 11

Date: 5/27/2021

a. Description.

This project is located on Vanguard Drive starting from the eastern edge of Telegraph Road and ending approximately 637 feet to the east along Vanguard Drive in the City of Pontiac in Oakland County.

This project will be constructed under two-way traffic during all stages of the project as detailed in the MOT plans.

Stage 1 through Stage 2A shall maintain two-way traffic along Vanguard Drive while half-width removals take place along the southern and northern half of the drive as detailed in the plans. During these stages, two-way traffic shall be maintained at all times on the compacted aggregate base until prepared for compacted concrete pavement (CCP) operations.

Stage 3, Vanguard Drive shall be closed to commercial traffic during compacted concrete production. Paving operations shall not begin until after 2 p.m. on Saturday, September 4, 2021, after FedEx has shutdown trucking operations for the Labor Day holiday weekend. All paving production along Vanguard Drive, each side, shall be complete and the road must be approved for traffic before 12 a.m. September 7, 2021, unless otherwise specified by the Engineer or the City. During this stage, the contractor shall allow through "light traffic" and emergency vehicles at all times for local business facilities as outlined in the compacted concrete special provision when required.

Stage 3A, shall be an alternate stage that would replace Stage 3 if the contractor chooses. This stage allows half-width pavement operations and the entire road shall be approved for traffic within four (4) days. During half-width paving operations two-way traffic shall be maintained at all times on the aggregate base of the opposing side. During this stage, the contractor shall perform half-width paving operations and traffic will not be allowed to be shifted onto the new CCP until approved for traffic. During cure time traffic shall remain on the aggregate base of the opposing side of Vanguard Drive. Once the new CCP is approved for traffic the contractor may proceed with paving operations of the other half of Vanguard Drive and maintain two-way traffic on the new CCP. During paving operations of each half of Vanguard Drive two-way traffic shall be maintained at all times and emergency vehicles shall always have access.

During all stages of the project, a single right lane closure shall be maintained along Telegraph Road until Vanguard Drive is approved for traffic. The contractor will be required to maintain temporary traffic control devices along Telegraph Road and perform daily inspections for any damaged or out of place signage as directed by the engineer. Once the entire area of Vanguard Drive has been approved for traffic the contractor shall remove the lane closure along Telegraph Road immediately unless directed otherwise by the engineer.

b. General

Traffic shall be maintained by the Contractor throughout the project as shown on the plans, attachments, and in accordance with Subsections 104.07, 104.11, and Section 812 of the Michigan Department of Transportation 2012 Standard Specifications for Construction, including any supplemental Specifications, and any special provisions in this proposal. All traffic devices and their usage shall conform to the Michigan Manual of Uniform Traffic Control Devices (MMUTCD), 2011 edition, as amended.

1. **Notice of Traffic Control** - The Contractor shall notify the Engineer, City of Pontiac, and the local police and emergency agencies, transit bus agencies, school bus agencies, and cities a minimum of five business days prior to implementation of any detours, ramp closures, lane closures or major traffic shifts. Contact information for said agencies is as follows:

| | |
|--------------------|---|
| Fire Department: | 248-673-0405 (Waterford Regional Station 6) |
| Police Department: | 248-409-7100 (Oakland County Sheriff) |
| SMART Bus | 248-419-7905 (Regional Transit Authority) |
| Garbage Pickup: | 248-830-8099 (Advanced Disposal) |

2. **Coordination of Work** - The Contractor shall coordinate this work with other Contractors, other Contractors performing work within or adjacent to the Construction Influence Area (CIA), to avoid conflicts in the maintenance of traffic, construction signing, and to provide for the orderly progress of contract work. Refer to the *Notice to Bidders Project Coordination* located elsewhere in this proposal for more information regarding area projects, if any.
3. **Road Maintenance** – The City of Pontiac or contract maintenance agencies may perform maintenance work within or adjacent to the Construction Influence Area (CIA). These agencies will coordinate their operations with the Engineer to minimize the interference to the Contractor. No additional payment will be made to the Contractor for the joint use of the traffic control items or delays and/or inefficiencies resulting from maintenance activities.
4. To maintain the mobility of traffic and pedestrians, every attempt should be made to follow the maintaining traffic plans, maintaining traffic typicals, and specifications provided. Any change of or variation from the maintaining traffic plan shall be approved by the Engineer prior to implementation.

c. Construction Influence Area.

In addition to the definition in the *MDOT Standard Specification for Construction*, the Construction Influence Area (CIA) shall include the area within the road right-of-way, including intersecting roadways or ramps, to the limits of advanced construction signing, or any other signs that pertain to this location. In addition, the CIA includes the right-of-way of any designated detour route, intersecting road, or ramp adjacent to the work zone as far as the construction detour signing extends.

d. Traffic Restrictions

This project shall be constructed under traffic and the Contractor's operations shall be limited by local municipality time and noise ordinances as stated in the progress clause

1. Speed limit Reductions
 - A. Two-way direction speed reduction shall be in place where contractors are present along Telegraph Road unless otherwise shown on the plans or approved by the Engineer.
2. Access to Private Property
 - A. During Construction, access to Vanguard Drive shall be maintained at all times to businesses and other facilities as shown on the plans or as defined by the Engineer.
3. Lane Closures
 - A. A minimum lane width of 11 feet shall be maintained along Vanguard Drive unless otherwise indicated on the plans or approved by the Engineer.
 - B. Once work is initiated which requires lane closures, the work shall be continuous until completed within the restricted hours. If the engineer determines that the work can be completed without the use of a lane closure the contractor shall remove all traffic devices at the engineer or City's request immediately. A lack of work activity for more than three (3) calendar days unless otherwise approved by the Engineer will require the removal and replacement of lane restrictions at the Contractor's expense.
 - C. No lane closures or flagging sequences will be allowed where the Contractor is not working or can accomplish the work without closure in the opinion of the Engineer. Lane closures and flagging operations will be allowed only in areas and situations deemed necessary by the Engineer. This lane closure prohibition or approval by the Engineer includes brief closures for truck loading and unloading, dumping, etc. This project shall be constructed under traffic per the above-mentioned specifications and the maintaining traffic diagrams and notes in the plans.
 - D. Maintain two-way traffic and left the turn lane at the intersection with Telegraph Road at all times during all part width construction stages in accordance with the plans and as directed by the Engineer. No road closures will be allowed outside of Stage 3 as shown on the plans.
 - E. During all stages of the project maintain access for all business, local traffic, and emergency vehicles (if required) at all times. Only during stage 3 shall local traffic be restricted to "light traffic" and emergency vehicles only.
 - F. The Contractor will be required to provide plastic drums or channeling devices at pavement edge drop-offs to protect the traffic and the work as directed by the Engineer (generally at a drop-off greater than 3 inches). Maintaining traffic, part width construction will not be paid for separately but is included with the cost of traffic control and other items of work shown on the plans.
4. Work at Intersections
 - A. Maintain Traffic at the following intersection throughout the project as shown on the plans and as directed by the Engineer:
 - (1) **Telegraph Road and Vanguard Drive** – Maintain traffic in all directions throughout the project. Right lane closures shall be placed at or in advance of this intersection along Telegraph Road as shown on the plans and as directed by the engineer. Signal staging will be required throughout the stages but all

directions of traffic shall be maintained during each stage as shown on the plans or as directed by the engineer.

- a) **Stage 1-** Maintain two-way traffic along the southern half of Vanguard Drive while pavement removals take place along the other half. Right lane closure along N.B. Telegraph Road shall be in place during this stage following the MDOT 123-NFW-1LC-(R) typical detail for an undivided roadway. The single right lane closure along Telegraph Road shall be in place during all stages of the project until Vanguard Drive is approved for traffic or if otherwise specified by the engineer. All other traffic lanes shall not be impacted and remain open at all times. Signal staging will be required for this stage to maintain turning traffic to and from Vanguard Drive. See signal staging plans for further detail.
- b) **Stage 2 –** Maintain two-way traffic on Vanguard Drive along the previous stage 1 work zone area on the compacted aggregate base. Along Telegraph Road the northbound right lane closure shall be in place during this stage following the MDOT 123-NFW-1LC-(R) typical detail but barricades and barrels at the entrance of Vanguard Drive shall be moved to close off the southern half of the boulevard. All other traffic lanes shall not be impacted and remain open to all traffic. Signal staging will be required for this stage to maintain turning traffic to and from Vanguard Drive. See signal staging plans for further detail.
- c) **Stage 2A –** This stage shall be completed on a Saturday after 2 p.m. when FedEx trucking operations are closed for the remainder of the week. Once work has started during this stage it shall be continuous until the compacted aggregate base is installed through for through traffic. Removals during this stage shall be half-width and a single lane of traffic shall be maintained at all times.
- d) **Stage 3 –** Work during this stage shall not begin until after 2 p.m. on September 4, 2021, after FedEx trucking operations have closed for the Labor Day holiday weekend. All paving for this stage shall be completed no later than September 6, 2021, by 12 a.m. and the road shall be approved for traffic no later than September 7, 2021, before 12 a.m. During this stage, a single lane of traffic must be maintained at all times for through light traffic and emergency vehicles during paving operations. Once a single side has been completely paved, local light traffic shall be allowed through on the compacted concrete pavement as outlined in the special provision for compacted concrete pavement. All other commercial traffic, other than emergency vehicles, will not be not allowed until the compacted concrete pavement is approved for traffic.
- e) **Stage 3A –** This stage shall be an alternate option to Stage 3 if the contractor should choose or if weather conditions prohibit paving during the holiday weekend as outlined in Stage 3. This stage shall be half-width construction where the second half of the boulevard shall not be paved until the first half is approved for traffic. During this stage traffic shall be maintained at all times in both directions either on the compacted

aggregate base or on the compacted concrete pavement once it has been approved for traffic. This stage is anticipated to be completed over an extended amount of time, up to a maximum of four 4 days, for all lanes to be approved for traffic.

e. Staging

Complete work in consecutive stages. Unless otherwise approved by the Engineer, work operations in the preceding stage must be complete before beginning the next stage. Access to Vanguard Drive shall be maintained at all times throughout the project and staging operations unless otherwise approved by the City or Engineer.

Stage 1:

Notes:

1. Maintained 2-way traffic along the southern half of Vanguard Drive at all times while maintaining 2 lanes for left and right turn traffic at the intersection signal with Telegraph Road.
2. Left turns for southbound traffic along Telegraph Road to Vanguard Drive shall be maintained at all times during this stage.
3. Traffic control devices for right lane closure along Telegraph Road shall be in place prior to starting of concrete removal along Vanguard Drive and shall remain in place until the project end.
4. Minimum lane widths shall be 11 feet unless otherwise approved by the Engineer.
5. Tapering of traffic along Telegraph Road shall be per MDOT Maintaining Traffic Typical 123-NFW-1LC-(R) unless otherwise shown on the plans.

Sequence of Construction:

1. Install lead-in signs
2. Install right lane closure along Telegraph Road
3. Traffic signals to be staged
4. Perform the work (in no particular order): Conc. remove, proposed storm sewer, utility structure adjustments, curb and gutter, aggregate base, misc.

Stage 2:

1. Maintain two-way traffic along the northern side of Vanguard Drive on the proposed aggregate base.
2. Shift traffic control devices along Telegraph Road as required for right lane closure and maintaining traffic along Vanguard Drive.
3. Minimum lane widths shall be 11 feet unless otherwise approved by the Engineer.
4. Tapering of traffic along Telegraph Road shall be per MDOT Maintaining Traffic Typical 123-NFW-1LC-(R) unless otherwise shown on the plans.

Sequence of Construction:

1. Relocate right lane closure barrels as required or as shown on the plans to maintain traffic along Vanguard Drive and to close off the work area for Stage 2.
2. Traffic signal staging to be revised for this stage to maintain in and out traffic from Telegraph Road.
3. Perform the work (in no particular order): Conc. remove, proposed storm sewer, utility structure adjustments, curb and gutter, aggregate base, misc.

Stage 2A:**Notes:**

1. Work to be completed during the weekend and after hours of operation of the FedEx Distribution Center as outlined above.
2. A single lane shall be maintained at all times within the work zone area to allow through traffic as shown on the plans or specified by the engineer.
3. Maintain a minimum lane width of 11 feet at all times unless otherwise approved by the Engineer. Once work has started it shall be continuous from start to finish as shown on the plans or specified by the engineer.

Sequence of Construction:

1. Remove signal staging
2. Realign barrels or channeling devices along Vanguard Drive for through traffic and existing signal alignment.
Perform the work (in no particular order): Conc. remove, proposed storm sewer, utility structure adjustments, curb and gutter, aggregate base, misc

Stage 3:**Notes:**

1. Work to be completed over Labor Day weekend starting not earlier than 2 p.m., September 4, 2021, and completed as outlined above unless otherwise approved by the City or Engineer.
2. Light Traffic and emergency vehicle access shall be maintained during this stage at all times while any other commercial traffic will not be allowed.
3. Once work has started it shall be continuous from start to finish and the road must be open to all traffic by 12 am September 7, 2021.

Sequence of Construction:

1. Realign barrels and barricades for paving operations.
2. Condition aggregate base if required before paving while maintaining traffic on the other half.
3. Perform the work (in no particular order): Aggregate base conditioning, Compacted Conc. Paving, misc.

Stage 3A:**Notes:**

1. Work shall be complete by half-width construction while maintaining traffic on the other halves during concrete production.
2. Two-way traffic for all vehicles shall be shifted on the other half of new compacted concrete once approved for traffic.
3. This stage may be constructed any day of the week and may take multiple days to be complete.
4. Once work has started it shall be continuous from start to finish, each half, and the road must be open to all traffic at all times.

Sequence of Construction:

1. Realign barrels and barricades for paving operation stages.
2. Condition aggregate base if required before paving while maintaining traffic on the other half.
3. Perform the work (in no particular order): Aggregate base conditioning, Compacted Conc. Paving, misc.

Any additional traffic control devices required as a result of the Contractor requesting to conduct work operations different from the above schedule will be at the Contractors expense. Payment for the staging will be paid for using Contractor-provided **Traffic Regulator Control, Minor Traf Devices, Sign, Type B, Temp, Prismatic, Furn, Sign, Type B, Temp, Prismatic, Oper, Plastic Drum, Fluorescent, and Channelizing Device, 42 inches, Fluorescent** as directed by the Engineer.

f. Traffic Switches and Traffic Signal Cutovers

A traffic switch/traffic signal cutover is defined as a shift of traffic from the lanes being used currently to some new configuration or modification of existing pedestrian facilities, using either temporary or permanent pavement and traffic control devices. The Engineer will determine if the Contractor's means of traffic control are subject to the requirements of this section. If the intersection's current configuration has pedestrian heads, at no time during construction shall the intersection operate without functioning pedestrian heads.

The Contractor is responsible for planning and safely completing any traffic switches required for this project. Traffic switches will not be allowed on Fridays, Saturdays, or Sundays. They shall commence no earlier than 9:00 a.m. and be completed no later than 3:00 p.m. The Contractor is required to schedule and hold a scheduling/coordination meeting, one week prior to the date the Contractor wishes to switch traffic. Any SubContractor performing work for the traffic switch must attend. The Contractor shall also invite a representative from the local government, law enforcement, City of Pontiac Engineering, RCOC Signal Systems Division, and the Project Engineer. At, or prior to, this meeting, the Contractor shall submit to the Project Engineer, for his review and approval, a schedule of work and the timing for that work for the prime Contractor and every SubContractor performing work needed for the traffic switch. The Contractor will be responsible for scheduling any law enforcement officer(s) needed to direct traffic during the traffic switch and must advise as to the expected and reasonable duration of their presence. Likewise, the Contractor is responsible for ensuring the presence, at the appropriate times and in accordance with the approved schedules, of every Subcontractor performing work for the traffic switch. No traffic switches will occur before such a meeting is held, and at least one week will elapse after the meeting before the traffic switch is allowed. If the Project Engineer deems that the necessary personnel is not present, the traffic switch will be canceled and rescheduled, subject to all of the requirements of this section, without consideration for an extension of time. Failure to complete a traffic switch by 3:00 p.m. will result in liquidated damages in the amount of \$5000 per hour for every hour after the deadline until the switch is completed, assessment being for any portion of an hour, not the completion of an hour (i.e., at 3:01 p.m. a \$5000 penalty, at 4:01 p.m., another \$5000 penalty, etc.).

g. Pedestrian Access

1. No more than one sidewalk or non-motorized path on either side of the road shall be under construction at one time.
2. Pedestrian access to sidewalks shall be maintained at all times.

h. Traffic Signal Work

1. General

In addition to other sections of this specification, traffic control devices for traffic signal work shall be in accordance with the MDOT Maintaining Traffic Typical M0020a, M0050, M0240a, and M0270a or as approved by the Engineer. These typicals are to be

used for traffic signal work only and the "Road Work Ahead" sign (W20-1) shall be replaced with the "Signal Work Ahead" sign (W20-1 Modified). In M0050a, the "Traffic Fines Doubled In Work Zones" sign (R5-18) and "Injure / Kill A Worker \$7500 + 15 Years" sign (R-18b) shall not be placed or paid for.

2. Traffic Restrictions

It will be the Contractor's responsibility to make arrangements for police assistance when it is necessary to take a signal out of service.

Trucks stationed within the traveled way shall be equipped with properly operating strobe flashers, or flashing bars, or both from 360 degrees.

All traffic signal cutovers, lane closures, and stage changes must be in accordance with the traffic switch and traffic signal cutovers section.

3. Material Requirements

All work zone signing shall meet the requirements for "Flexible Roll Up Signs" or "Prismatic Sheeting" Type VII (Orange must be fluorescent).

Traffic Control materials selected for use on this project shall be on the MDOT Qualified Products List (QPL).

4. Measurement and Payment

The project quantities for traffic control are based on the Contractor having two crews working at separate locations on the project at the same time, with their own set of traffic control items. The quantities assume four approach intersections with a lane closure set-up on two approaches at both locations. The Contractor will be limited to working at two locations at a time unless prior approval is obtained from the Project Engineer. If the Contractor works at more than two locations at the same time, the additional quantities of traffic control items required will not be paid for but will be the responsibility of the Contractor to supply at their own cost. Cones are to be used for daytime closures only and are included in the Minor Traffic Devices pay item. All temporary closures are to be removed at the end of each day, including all cones and temporary signs.

i. Traffic Control Devices

1. General

A. All traffic control devices moved to facilitate the Contractor's operation shall be reset by the end of the workday. The Contractor shall routinely maintain all traffic control devices. Routine Maintenance includes, but is not limited to, maintaining proper placement, replacing damaged devices, and cleaning. The Contractor shall be responsible for reviewing the adequacy and maintenance of all traffic control devices at least once per day, every day, for the duration of this project. Weekly Service Reports shall be made available to the Engineer upon request for review and payment.

B. All items used for maintaining traffic, which includes but are not limited to, temporary signs, plastic drums, and type III barricades, must meet the acceptance criteria as defined in the most current version of the American Traffic Safety Service Association (ATSSA publication), entitled "Quality Guidelines for Temporary Traffic Control Devices and Features" at the time of initial deployment and after each stage.

- C. All traffic control devices, except Portable Changeable Message Signs (PCMS) and lighted arrows, must be approved by FHWA and MDOT as meeting NCHRP 350 crashworthy requirements and meet acceptable criteria as defined in the current American Traffic Safety Service Association (ATSSA) publication entitled, *Quality Guidelines for Traffic Control Devices and Features*. The Contractor shall notify the Engineer at least 72 hours in advance of erection or removal of signs.
- 2. Signs
 - A. All diamond signs shall be 48 in x 48 in unless otherwise noted.
 - B. Mount all temporary signs, regardless of size, that will be in place for more than 14 days on driven posts. Place ground-driven sign systems as described in MDOT plan WZD-100 Series. Temporary signs less than or equal to a 20 square foot sign area that will be in place for less than or equal to 14 days may be mounted on driven posts or portable systems with bases adequately sandbagged against overturning.
 - C. Distances shown between construction warning, regulatory and guide signs shown on the plans, or any typicals referred to by the plans, are approximate and may require field adjustment, as directed by the Engineer. Signs improperly placed or installed by the Contractor without the Engineer's representative present shall be relocated and reinstalled by the Contractor as directed by the Engineer without extra compensation.
 - D. The Contractor shall stake all temporary signs for the Engineer to review prior to installation. 72 hours advanced notice is required.
 - E. The location and placement of the permanent signing shall be marked in the field by the Project Engineer. The Contractor shall notify the Project Engineer a minimum of two weeks in advance of when permanent signing will be needed.
 - 3. Pavement Markings
 - A. All temporary and permanent pavement markings shall be placed by the Contractor but shall be laid out in the field by the Project Engineer. The Contractor shall notify the Project Engineer a minimum of one week in advance.
 - 4. Channelizing Devices
 - A. Channelizing Devices, 42 inch will be utilized due to 11 ft lanes during construction.
 - 5. Mobile Attenuators
 - A. This is part of the project contract. No pay items are included for this work.
 - j. **Contractor Responsibilities – Construction signing (Lead-in, Detour Route, Work Zone, and Signal Staging)**
 - 1. All related construction signing, including lead-in or advanced warning signing, shall be provided, staked, erected, and maintained by the Contractor. The Contractor will be responsible for providing and erecting all signs including lane closure devices/signing for maintaining traffic.
 - 2. Maintain traffic and adhere to MDOT Maintaining Traffic Typical M0240a and M0510a as shown on the plans.
 - 3. **Coverings:** The Contractor shall uncover and cover signs which need covering at any time as directed by the Engineer.

4. **Sandbags:** The Contractor shall place a minimum of eight sandbags on any and all signs and devices not inserted into the ground to prevent movement.
5. **Lights:** Attach and maintain two (2) steady burn amber lights (type "C") on each Type III barricade, if any are indicated on Construction Signing Diagram.
6. **Maintenance of Signs:** The Contractor shall maintain all signs and devices as directed by the Engineer (including but not limited to cleaning, re-erecting fallen signs and devices, replacing damaged or dead lamps, moving non-ground-inserted signs and devices, etc.). The Contractor shall reimburse the City of Pontiac for the cost of any temporary and or permanent traffic signs and or devices the Contractor may damage. All the City of Pontiac -supplied signs and devices shall remain the property of the City of Pontiac and will be removed from the project by the City of Pontiac upon completion as directed by the Engineer.
7. **Signs and Devices:** Temporarily reset existing traffic control and street-name signs as directed by the Engineer. Upon completion of the work that required the temporary relocation, replace or reset all such signs in their original locations as directed by the Project Engineer upon construction completion. The Contractor shall reimburse the City of Pontiac for the cost of any/all permanent traffic signs and/or the City of Pontiac owned devices the Contractor may damage.

k. Contract Adjustment - Signs

Multiple mobilizations for both existing and temporary construction sign removals will be required and are included in the respective pay items.

Any temporary construction signs, and related appurtenances, pertaining and only relevant to a stage that has been completed, shall be removed by the Contractor on the day of the switch to the subsequent stage. This includes detour and road closure signs that no longer apply due to opening to traffic. Failure to do so will result in the Contractor being assessed a negative adjustment of \$500 per calendar day for each day that those signs remain. These removals will not be paid for separately, and are included in the original items of work.

All temporary construction signs and related appurtenances shall be removed from the project no later than the date identified in the Progress Clause for the completion of the placement of final restoration items and/or when remaining items of work are minor and can be completed by the Contractor by daily construction zone signing, as determined by the Engineer. Failure to do so will result in the Contractor being assessed a negative adjustment of \$500 per calendar day for each day that those signs remain.

Any permanent signs, and related appurtenances, designated by the Engineer as inappropriate for a stage, will be removed on the day of the switch to that stage. Failure to do so will result in the Contractor being assessed a negative adjustment of \$500 per calendar day for each day that those signs remain. This work will be paid for as Sign, Type__, Rem or Sign, Type__, Erect, Salvage.

If the Engineer invokes 12SP812(C), 812.03.C.1.c.ii (corrective action by others), the Contractor will be charged accordingly any costs incurred to complete the required corrective action by the Department including labor, equipment, and material costs.

I. Measurement and Payment.

The estimate of quantities for maintaining traffic on this project is based on the suggested sequence of operations. Payment shall be in accordance with Sub-Section 812.04 of the *2012 Standard Specifications for Construction* and any supplemental specifications unless otherwise specified.

1. Payment for quantities used to maintain traffic will be based on the maximum number of units required by the Engineer at any one time for the entire project and have been estimated based on the attached typical.
2. Delays in construction and coordination of the operations due to traffic maintenance conflicts with other construction projects will be considered as a basis for extension of contract time, but will not be considered a basis for extra compensation for suspensions of work, idled equipment, or labor.
3. Any signs desired by the Contractor that are approved by the Engineer but not required by the Engineer may be placed and removed by the Contractor at the Contractor's expense.
4. Other traffic control items shown on the plan to be provided by Contractor plus setting up and removing and/or moving these items to the side traveled way as necessary per plan each workday shall be paid for at the contract unit price for that item.
5. Additional special signs may be necessary; therefore, the quantity for Sign, Type B, Temp, Prismatic, Furn (Sft); Sign, Type B, Temp, Prismatic, Oper (Sft) has been increased for use as directed by the Engineer. Any unused quantity will not be paid for.
6. The cost of signs and other devices shown on plans to be provided by Contractor plus setting up and removing these signs as necessary per plan each workday is included in the contract unit prices for Sign, Type B, Temp, Prismatic, Furn (Sft); Sign, Type B, Temp, Prismatic, Oper (Sft); and Minor Traf Devices (Ls).
7. Additional quantities of Type III Barricades have been included for use at the discretion of the Engineer. Any unused quantity will not be paid for.
8. Any additional plastic drums required by the Engineer will be measured and paid for at the unit prices for Plastic Drum, Fluorescent, Furn, and Plastic Drum, Fluorescent, Oper.
9. The contractor provided sign covering and uncovering, and other work specified above on the City of Pontiac signs shall be included in the contract unit price for TS, Bag (Ea), TS, Bag, Rem (Ea), Sign Cover (Ea).
10. Minor Traf Devices (Ls) is part of this contract and includes any traffic cones, lights, signs, sandbags, orange safety fencing, and/or channelizing devices other than plastic drums required by the Engineer.

CITY OF PONTIAC
NOTICE TO BIDDER
PAVEMENT CORES

HRC

Page 1 of 7

Date: 5/20/2021

a. General

G2 Consulting Group, LLC extracted pavement cores from Vanguard Drive on May 5, 2021. G2 Consulting Group, LLC findings, Attachment A, are hereby made as part of this Notice to Bidders. Approximate locations of each pavement core have been provided on the Soil Boring Location Plan provided by G2. Note that pavement conditions vary throughout the project and pavement cores depict point locations and do not infer that the surface and subsurface conditions are the same in other areas. Pavement core logs provided herein are for reference only. A detailed geotechnical investigation and analysis has not been performed.

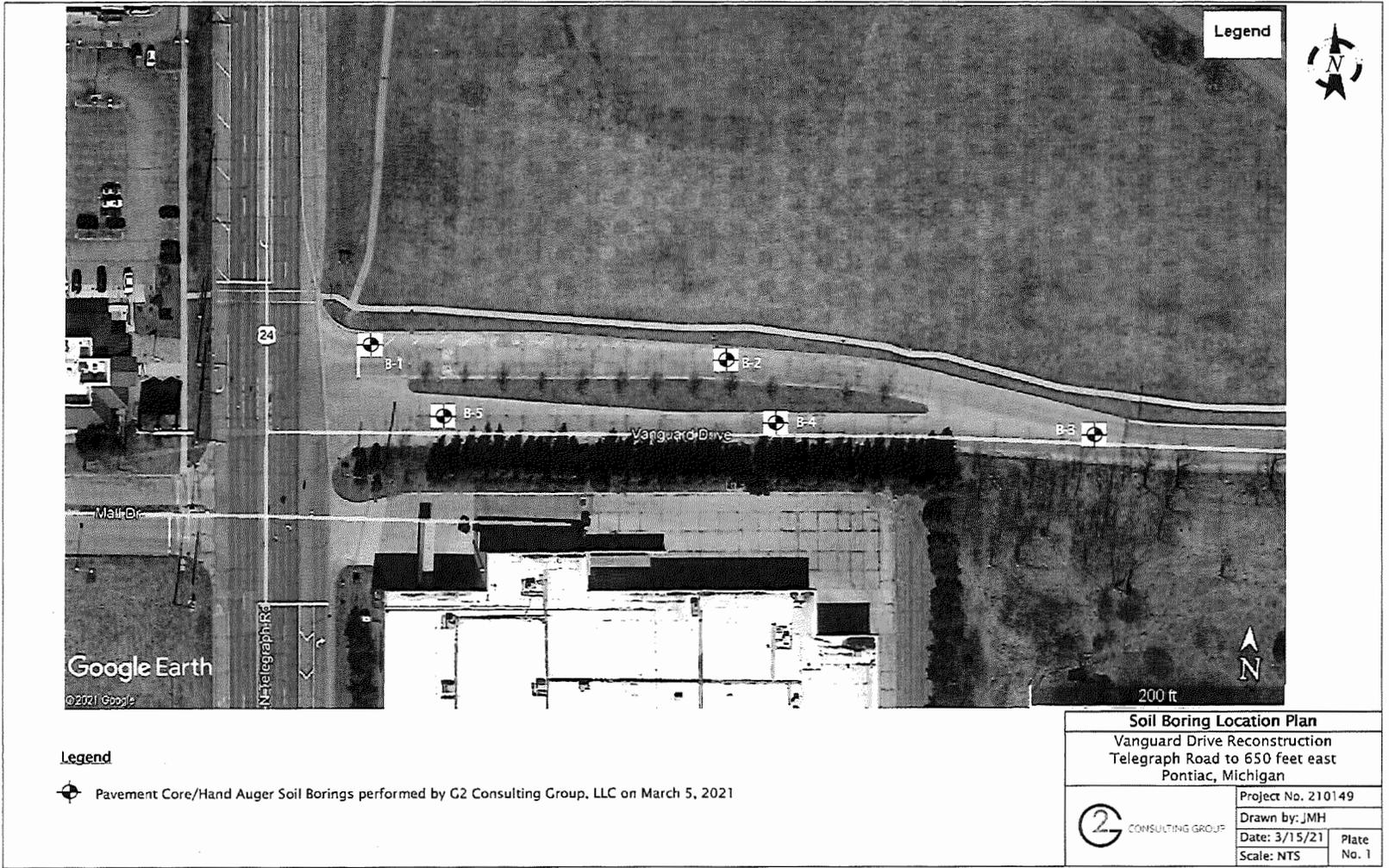

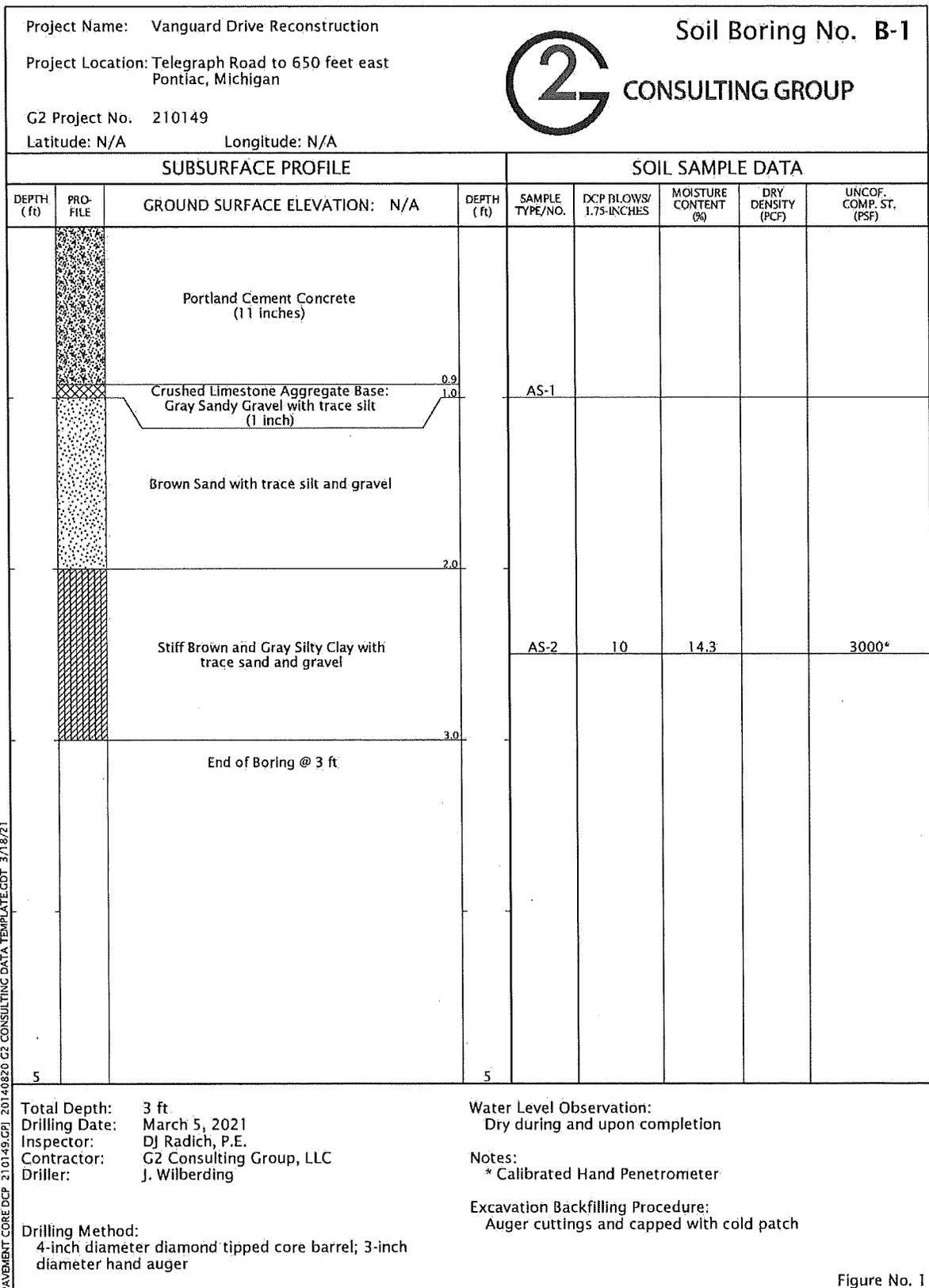

PAVEMENT CORE DCP 210149.GPJ 20140820 G2 CONSULTING DATA TEMPLATE.GDT 3/18/21

Figure No. 1

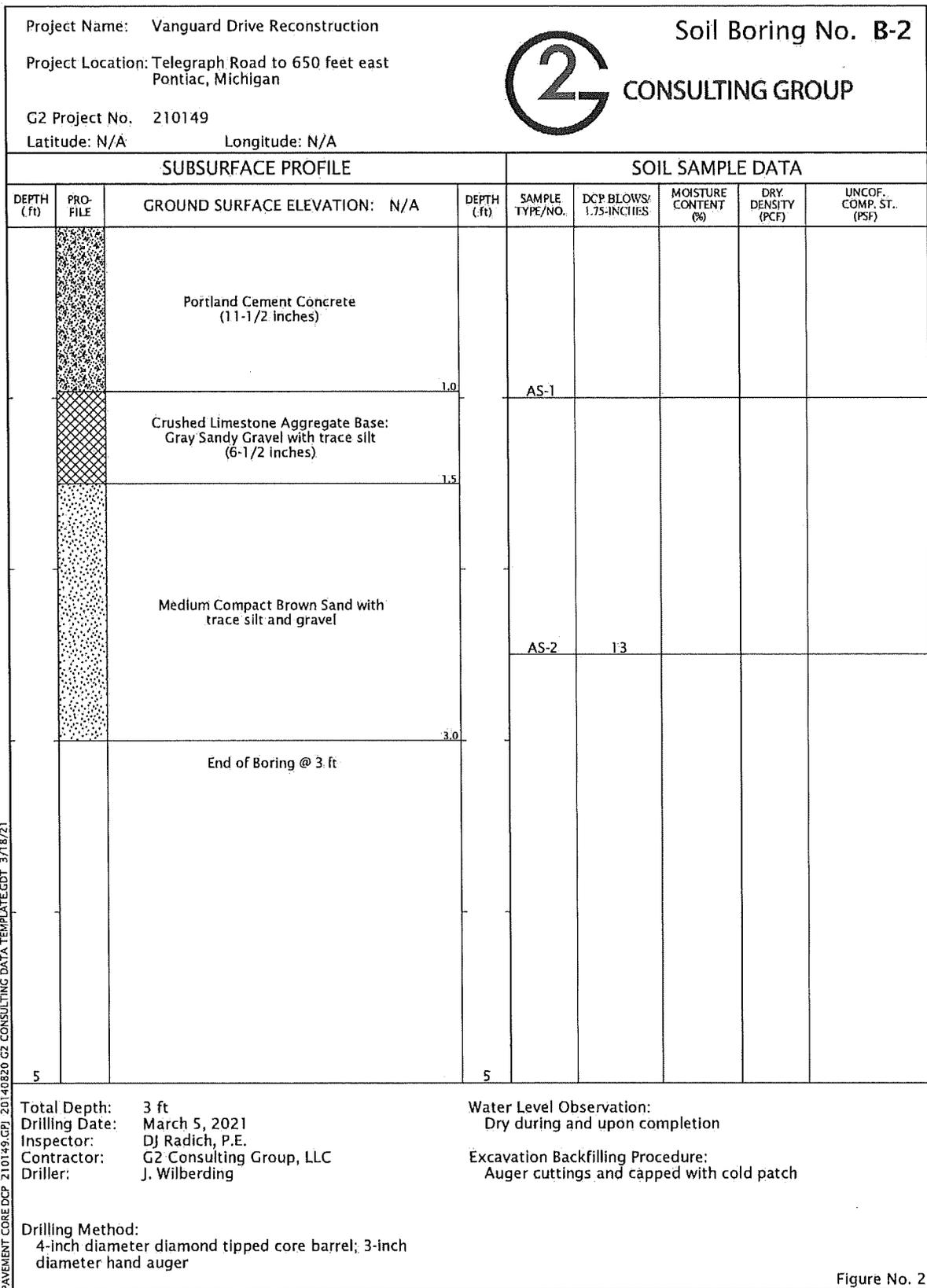

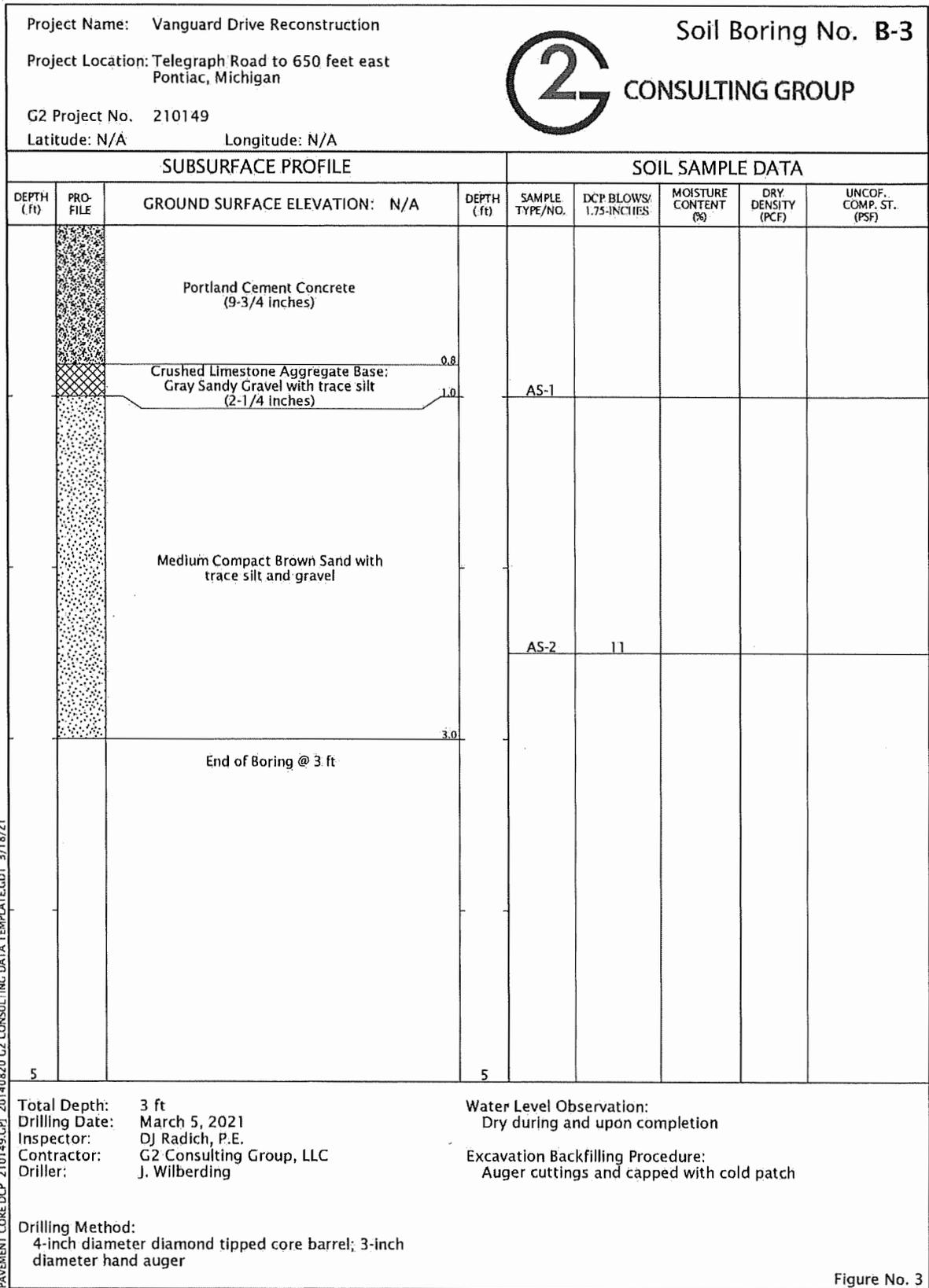

PAVEMENT CORE DCP 210149.CPJ 20140820 G2 CONSULTING DATA TEMPLATE.GDT 3/18/21

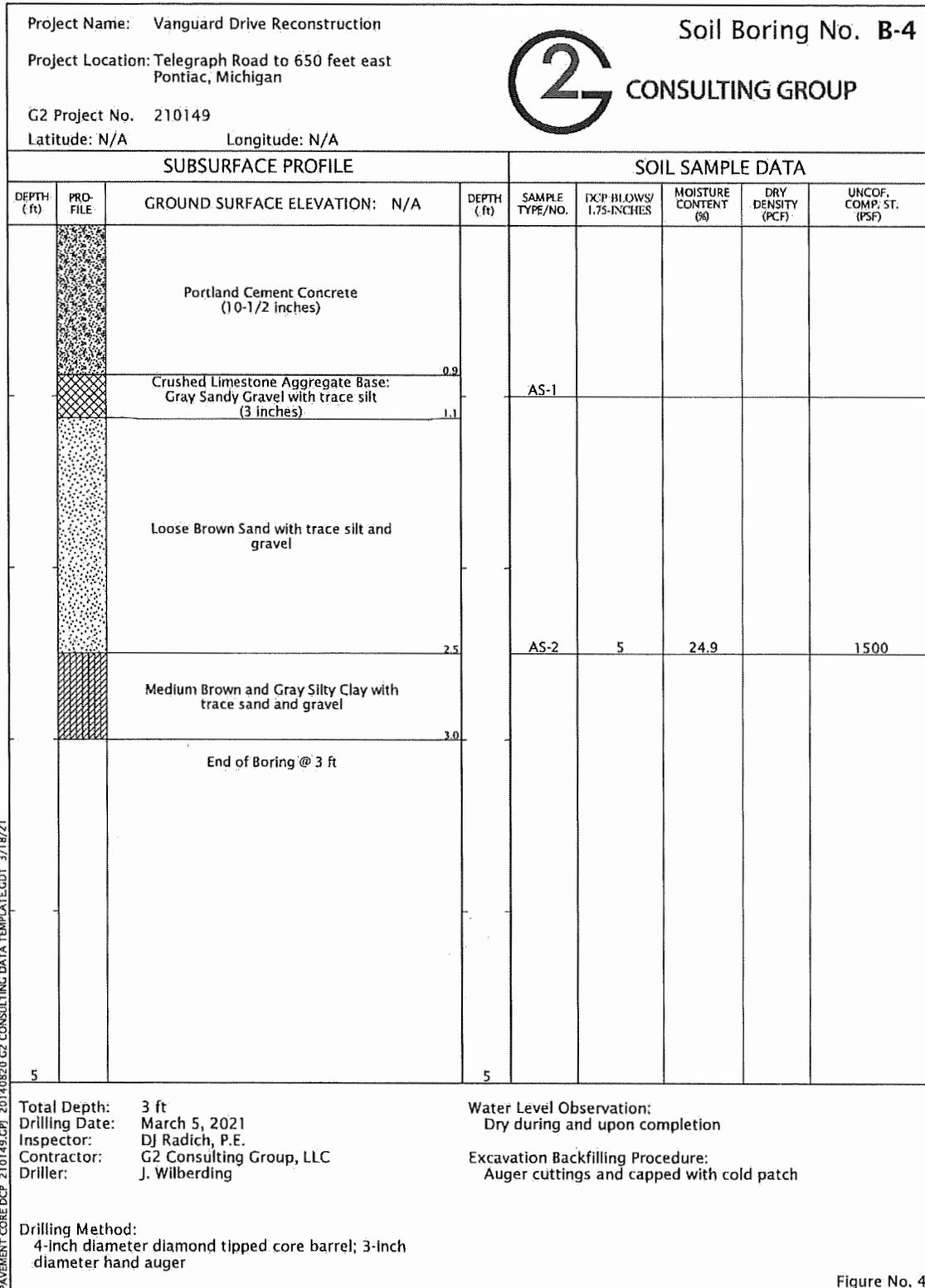

| Project Name: Vanguard Drive Reconstruction | | | Soil Boring No. B-5 | | | | | |
|---|----------|--|--|-----------------|------------------------|----------------------|-------------------|------------------------|
| Project Location: Telegraph Road to 650 feet east Pontiac, Michigan | | |  | | | | | |
| G2 Project No. 210149 | | | | | | | | |
| Latitude: N/A | | | Longitude: N/A | | | | | |
| SUBSURFACE PROFILE | | | SOIL SAMPLE DATA | | | | | |
| DEPTH (ft) | PRO-FILE | GROUND SURFACE ELEVATION: N/A | DEPTH (ft) | SAMPLE TYPE/NO. | DCP BLOWS/ 1.75-INCHES | MOISTURE CONTENT (%) | DRY DENSITY (PCF) | UNCOF. COMP. ST. (PSF) |
| | | Portland Cement Concrete (8-3/4 inches) | 0.2 | | | | | |
| | | Crushed Limestone Aggregate Base: Gray Sandy Gravel with trace silt (6-1/4 inches) | 1.3 | AS-1 | | | | |
| | | Loose Brown Sand with trace silt and gravel | 3.0 | AS-2 | 8 | | | |
| | | End of Boring @ 3 ft | 5 | | | | | |
| Total Depth: 3 ft Drilling Date: March 5, 2021 Inspector: DJ Radich, P.E. Contractor: G2 Consulting Group, LLC Driller: J. Wilberding | | | Water Level Observation: Dry during and upon completion Excavation Backfilling Procedure: Auger cuttings and capped with cold patch | | | | | |
| Drilling Method: 4-inch diameter diamond tipped core barrel; 3-inch diameter hand auger | | | | | | | | |

PAVEMENT CORE DCP 210149.GPJ 20140820 G2 CONSULTING DATA TEMPLATE.GDT 3/18/21

Figure No. 5

CITY OF PONTIAC
SPECIAL PROVISION
FOR
PROJECT CLEANUP

HRC

1 of 1

5/20/2021

DESCRIPTION

Project Cleanup shall follow Section 209 of the 2012 Michigan Department of Transportation Standard Specifications and City of Pontiac Standards and/or as specified herein.

CONSTRUCTION

All street/traffic signs and posts are considered to not be within the limits of construction, or considered to be able to be worked around, and therefore shall not be disrupted. If an existing sign cannot be avoided by the construction, the sign and post shall be removed from the ground and/or foundation. The removed sign and post shall be temporarily stored at a location where it is not impacted by construction activity or damaged. After construction has been completed, the salvaged existing sign and post shall be reinstalled at the original location or at a location identified by the Engineer. Any sign or post that is damaged during removal, transporting, storing or erection shall be replaced at the contractor's expense. This sign and/or post shall match the existing one in kind. All work related to the removal, storage, reinstallation and/or replacement of the existing sign/post shall be considered included in "Project Cleanup, Special".

This pay item is generally for the cleanup of all items disturbed by construction including removal of any miscellaneous items encountered during construction.

MEASUREMENT AND PAYMENT

The completed work, as measured, will be paid for at the contract unit price for the following contract item (pay item):

Pay Item

Unit

Project Cleanup, Special

Lump Sum

Project Cleanup will be paid out in 2 payments. The first payment (50% of the amount bid) will be made upon the completion of construction once the roadway has been inspected and "Approved For Traffic" by the Engineer. The second payment (remaining amount bid) will be paid upon the completion of all punch list, restoration and turf establishment items upon inspection and approval by the Engineer. The lump sum bid shall include all labor, materials, and equipment necessary to complete the work as described herein.

CITY OF PONTIAC
SPECIAL PROVISION
FOR
GEOTEXTILE FABRIC

HRC

1 of 2

May 27, 2021

a. Description

This work shall be in accordance with Section 910 of the 2012 Michigan Department of Transportation (MDOT) Standard Specifications for Construction, except as herein provided.

This special provision is to specify the material performance and physical properties of geotextile fabric material that is used in the Special Provision for Underdrains.

The general purpose of the Nonwoven Geotextile Fabric is to separate and stabilize two dissimilar materials to allow the roadway structure to perform as intended. The fabric shall provide a permeable layer, while retaining the soil matrix.

b. Materials

Geotextile fabric shall be stored and handled in accordance with the MDOT Standard Specifications for Construction and the manufacturer's recommendations.

At the time of installation, the geotextile fabric will be rejected if it has defects, tears, punctures, flaws, deterioration, damage to coatings, or any other damage incurred during manufacture, transportation, or storage.

1. Acceptance

Acceptance of geotextile fabric will be determined by the Engineer and shall be by testing or Test Data Certification, as specified in the MDOT Materials Source Guide, MDOT Materials Quality Assurance Procedures Manual.

The Contractor shall supply Test Data Certification for all materials delivered on site regardless of test method selected by Engineer.

A. Testing

If Engineer chooses to test, test results for acceptance may take up to 30 or more calendar days.

Acceptance will be based on test results being in conformance with the physical requirements, as shown below.

B. Test Data Certification

Acceptance will be based on Test Data Certification being in conformance with the physical requirements, as shown below.

2. Physical Requirements

Approved geotextile fabric material shall meet or exceed the following requirements:

| Physical Property at 50% Elongation per ASTM-4632 | Test Procedure | NW 8 |
|--|-----------------------|---------------------------|
| Weight, oz/yd ² | ASTM D-5261 | 8.0 |
| Grab Tensile Strength, lbs | ASTM D-4632 | 200 |
| Permittivity, per second | ASTM D-4491 | 0.05 |
| CBR Puncture Strength, lbs | ASTM D-6241 | 440 |
| Trapezoid Tear Strength, lbs | ASTM D-4533 | 80 |
| Apparent Opening Size (AOS) U.S. Standard Sieve | ASTM D-4751 | 70 max. (0.21 mm max.) |

c. Construction

All work must be in accordance with the contract documents, and as directed by the Engineer.

d. Measurement and Payment

All work must be in accordance with the contract documents, and as directed by the Engineer.

These materials will not be measured and paid for separately when called out as included in other pay items.

CITY OF PONTIAC
SPECIAL PROVISION
FOR
UNDERDRAINS

HRC

1 of 1

May 28, 2021

a. Description

This work shall be done in accordance with Section 404 of the 2012 Michigan Department of Transportation Standard Specifications for Construction, except as herein provided:

b. Materials

Geotextile Type NW-8 shall be used to line the underdrain trench as shown on the detail in the plans. The minimum overlap of the geotextile fabric shall be 2 feet.

The underdrain pipe shall be 6" diameter corrugated, perforated, polyethylene (PE) conforming to MDOT Standard Specification 909.07B (AASHTO M252).

The underdrain trench shall be backfilled with MDOT 34R open-graded aggregate and be in accordance with Section 902 of the 2012 Michigan Department of Transportation Standard Specifications for Construction.

c. Construction

Construct per the detail shown on the plans or as directed by the Engineer.

d. Measurement and Payment

| <u>Pay Item</u> | <u>Pay Unit</u> |
|--|-----------------|
| Underdrain, Subgrade, Open-Graded, 6 inch, Special | Foot |

Payment for **Underdrain, Subgrade, Open-Graded, 6 inch, Special** includes equipment, labor and materials to construct this item in accordance with the details shown on the plans and this special provision.

Payment for underdrain pipe, aggregate, and geotextile fabric required around the underdrain trench shall be included in the contract unit price for underdrain. No allowance will be made for extra material in laps.

CITY OF PONTIAC
SPECIAL PROVISION
FOR
COMPACTED CONCRETE PAVEMENT

MCA/HRC

1 of 9

May 28, 2021

a. Description. This work consists of the production and construction of a compacted concrete pavement (CCP) and includes furnishing all material, labor, and equipment necessary to prepare, place, and finish the work. Complete this work in accordance with this Special Provision.

b. Submittals. Submit the following to the Owner for review at least 30 days before beginning production of CCP:

1. Construction Schedule. Include details for all CCP related operations.
2. Plant Location. Show location and layout for mixing plant, cement and aggregate storage, and water supply.
3. Equipment. Include manufacturer's data and specifications for equipment to be used in mixing, hauling, placing, and compacting CCP.
4. Quality Control Plan as described in f.1.a.
5. Paving Plan. Include direction and pattern of paving, rolling and curing methods
6. Pavement Jointing Plan
7. Mix Design. Include details on proportioning, aggregate gradation and physical properties, cementitious materials, admixtures, and water/cement ratio and related data pertaining to the mitigation for deleterious Alkali Silica Reactivity (ASR) as described in c.5.

c. Materials.

1. Aggregates.
 - a. Must be from geologically natural sources
 - b. Shall meet the requirements indicated in Table 1.

Table 1: Grading Requirements for Combined Aggregate Blend

| Sieve Size | Percent Passing |
|------------|-----------------|
| 1 inch | 100 |
| 3/4 inch | 95-100 |
| 1/2 inch | 80-98 |
| 3/8 inch | 60-90 |
| No. 4 | 50-80 |
| No. 16 | 20-40 |
| No. 100 | 1-20 |
| No. 200 | 0-5 |

- c. Shall meet the physical requirements indicated in Table 2.

Table 2: Physical Requirements for Coarse Aggregates in Blend

| | |
|--|-------|
| LA Abrasion, % max (MTM 102) | 40 |
| Magnesium Sulfate Soundness (5 cycles), Loss, % max (ASTM C88) | 18 |
| Flat and Elongated Particles, ratio, % max | 15.0 |
| Soft Particles, % max, (MTM 110) | 2.0 |
| Clay Ironstone particles, % max | 1.0 |
| Chert, % max (MTM 110) | 2.5 |
| Sum of Soft Particles and Chert, % max (MTM 110) | 4.0 |
| Freeze Thaw Dilatation, % per 100 cycle max (MTM 115) | 0.067 |
| Maximum 24-hour soak absorption, % | 2.50 |

2. Cementitious Materials.
 - a. Cementitious shall meet the requirements indicated in Table 3

Table 3: Specifications for Cementitious Materials

| Cementitious Material | Type or Class | Specification |
|-----------------------|---------------|---------------|
| Cement | Type I or II | ASTM C 150 |
| GGBFS | Grade 100 | ASTM C 989 |
| Fly Ash | Class C | ASTM C 618 |
| Fly Ash | Class F | ASTM C 618 |

3. Water
 - a. Shall be from a potable source
4. Admixtures
 - a. Use admixtures as needed to achieve desired properties of the compacted concrete pavement. Provide material certification submittals for each product proposed to be used.
5. Concrete
 - a. The total cementitious materials content must be between 350 and 550 pounds per cubic yard.
 - b. A replacement of cement with GGBFS or Fly Ash is required and must be between 25 and 40 percent of the cementitious content by mass.
 - c. The Concrete Mixture must be resistant to deleterious alkali-silica reactivity (ASR).
 - i. An ASTM C 1293 test alone will not be sufficient to show that an aggregate is non-reactive with respect to deleterious ASR.
 - ii. Concrete Mixtures that include either of the following are considered to be resistant to Deleterious ASR:
 1. A 35% to 40% replacement of cement with GGBFS or Fly Ash
 2. A 25% to 35% replacement of GGBFS or Fly Ash and a cement with total alkalis not greater than 0.60% expressed as equivalent sodium oxide (percent Na₂O+0.658 x percent K₂O) as indicated on the submitted mill test report.
 - iii. At the discretion of the Owner, a Concrete Mixture may be considered resistant to Deleterious ASR if testing per ASTM C 1567 shows expansions of less than 0.10% for samples made with the same

aggregates, the same proportions of aggregates, the same cement, the same SCM and the same replacement % of cement with SCM as proposed for the Concrete Mixture.

- d. Develop a CCP mixture proportioned by the soil compaction method as follows:
 - i. For each cementitious content selected in the mixture proportioning process, use the modified proctor test method (ASTM D 1557) to determine the maximum dry density and the optimum moisture content.
 - ii. Develop moisture-density relationships for a minimum of three different cementitious contents. For each cementitious content, fabricate compressive strength specimens using the vibrating hammer method per ASTM C 1435. All specimens should be molded at the optimum moisture content corresponding to the cementitious content of the mix.
 - iii. Test the specimens for compressive strength at the selected cementitious contents. Plot the data and develop a compressive strength versus cementitious content curve. From this curve, select a cementitious content to meet the required minimum compressive strength of 4000 psi at 28 days per ASTM C 39. Use this cementitious content to construct CCP.
 - iv. Provide all data developed for this as part of the Mix Design submittal

d. Equipment. Provide and maintain equipment and tools necessary to construct CCP meeting the requirements for mixing, transporting, placing, compacting, finishing, and curing as provided in this Special Provision. Ensure that all equipment is available and/or on site, and approved by the Owner before beginning CCP mixing and/or paving operations.

1. Paver. Place CCP with a high-density paver. Spread and finish and compact the CCP material without segregation, to the required thickness, smoothness, surface texture, cross section, and grade using a paver of suitable weight and stability.
2. Water Truck. Have at least one water truck or similar equipment on-site and available throughout the paving and curing process. Equip the water truck with a spreader pipe containing fog nozzles capable of evenly applying a fine mist of water to the surface of the CCP without damaging the final surface.
3. Power Trowels. Provide ride-on power trowels to achieve a proper surface finish that is capable of being broom textured.
4. Brooms. Use brooms capable of installing proper texture depth for the type of traffic and facility use.
5. Saws. Have at least two early-entry saws available on-site. Have at least one saw available for sawing cold vertical joints as described in subsection d.5.a., "Cold Joints."

e. Construction.

1. Subgrade
 - a. Grade the subgrade to within one-half inch in ten feet of the design grade.
 - b. Compact the subgrade to not less than 95% of the maximum unit weight as determined by the method described in the MDOT Density Testing and Inspection Manual appropriate for the subgrade material.
 - c. Proof roll all subgrade using rubber-tired equipment of sufficient size and

- weight, as determined by the Owner, to identify any soft or yielding soils that require undercutting.
- d. At the discretion of the Owner, other devices such as Dynamic Cone Penetrometers may be used to evaluate the subgrade in lieu of or in addition to by proof rolling.
 - e. Undercut and replace soft or yielding soils in the subgrade using the specified materials and to the limits as directed by the Owner.
2. **Aggregate Base**
 - a. Grade the aggregate base to within three-eighths of an inch in ten feet of the design grade.
 - b. Compact the aggregate base to not less than 95% of the maximum unit weight as determined by the method in the MDOT Density Testing and Inspection Manual appropriate for the aggregate base material.
 3. **Mixing.** Use the same CCP mix proportions for the entire project, accounting for minor variations in moisture content. Ensure complete and uniform mixing of all ingredients. Check mixer blades routinely for wear and replace them if wear is sufficient to cause inadequate mixing.
 4. **Transportation.** Transport the CCP material to the paver in dump trucks, ensuring that there is no buildup of material in the truck beds. Place the material directly into the hopper of the paver or into a material transfer vehicle that deposits the material directly into the paver's hopper.
 5. **Placement.**
 - a. Aggregate Base: Uniformly moisten the aggregate base immediately prior to CCP placement.
 - b. Ambient Temperature
 - i. Cold Weather - Do not place concrete until the ambient temperature away from artificial heat is at least 25 degrees F and rising the ambient
 - ii. Hot Weather – Do not place concrete when the evaporation rate is greater than 0.20 pounds per square foot per hour at any time during the placement as calculated by the NRMCA following formula:

$$(T_c^{2.5} - r \cdot T_a^{2.5}) \cdot (1 + 0.4V) \cdot (1 \times 10^{-6})$$
 where:
 - a. T_c = Temperature of the concrete, degrees F.
 - b. r = Relative Humidity, % near the placement (as a decimal).
 - c. T_a = Ambient Temperature near the placement, Degrees F.
 - d. V = Wind Velocity near the placement, miles per hour.
 - c. Concrete Temperature: At the time of concrete placement ensure a concrete temperature between 45 and 90 degrees F.
 - d. Paving: Adjust the paver and regulate its speed to prevent segregation and to provide a surface course that is smooth and continuous without tears and pulling. Limit the spread of the CCP to a length that can be compacted and finished within the appropriate time limit under the prevailing air temperature, wind, and climatic conditions. Proceed in a steady, continuous operation with minimal starts and stops. Regulate speed to ensure a constant supply of CCP material in the hopper. Maintain CCP material above the auger shaft at all times during paving.

- e. Lift Thickness: Construct pavement in a single lift.
 - f. Adjacent Lanes: Place adjacent paving lanes within 60 minutes. If more than 60 minutes has elapsed between placements of adjacent lanes, the vertical joint will be considered a cold joint. Prepare the cold joint in accordance with subsection e.9.a, "Cold Joints." At the discretion of the Owner, the 60-minute time limit for adjacent lanes may be increased or decreased based on the use of set retarders and/or ambient weather conditions.
 - g. Segregation: If segregation occurs during paving, stop operations until the cause is determined and corrected. If the segregation is severe, remove and replace the affected area prior to continuing with paving.
6. **Compaction.**
- a. Begin compaction immediately behind the placement of CCP material and complete within 60 minutes of the start of mixing at the plant.
 - b. Do not operate compaction equipment within 12 inches of the edge of a freshly placed lane until the adjacent lane is placed. Within the allowable time, compact together both edges of the two lanes. Smooth out any uneven marks left during compaction. Compact until a smooth, flat surface is obtained, free of any tearing or cracking.
 - c. Compact the CCP until the In-Place Density for each moving average of 5 tests is no less than 98% of the maximum density per ASTM D 1557 at the optimum cement and moisture content established either during the Mix Design process (c.5) or prior to production.
7. **Finishing and Texturing.** Operate the power trowel machines to achieve a smooth surface finish that can receive a broomed texture. Drag brooms across the surface perpendicular to the paving direction to achieve the desired texture depth.
8. **Curing.** Immediately after final rolling and compaction testing, start curing the surface of the CCP using one or more of the following curing methods:
- a. ACE-iT Blue: Apply prior to power troweling.
 - b. Curing Compound: After texturing, apply curing compound that meets the requirements of ASTM C 309 Type 2, Class B within 30 minutes of the final rolling and compaction testing at a rate of at least 1 gallon per 25 square yards. Ensure that the application provides a uniformly white appearance across the entire CCP surface.
 - c. Water Cure: Apply water cure using water truck equipped with misting spray nozzles, soaking hoses, sprinkler system or other means that will ensure a uniform moist condition on the surface of the CCP. Apply the moisture in a manner that will not wash off or damage the surface of the finished CCP.
 - d. Polyethylene Sheeting: Use polyethylene sheeting, properly weighted down to prevent wind from affecting the surface.
9. **Joints.**
- a. Cold Joints: Joints between placements that occur greater than 60 minutes apart. Joints that are constructed utilizing a drop extension or edging shoe are exempt

from the following saw cutting requirement when placed up to 15 degrees from vertical.

Cut the joint vertically full depth at least 6 inches from the exposed edge. Cut 1/4 to 1/3 of the depth of the CCP and remove excess material. If the excess material cannot be removed without causing tearing or raveling, cut full depth.

Clean the joint of any loose or foreign material, and dampen the vertical surface prior to placing fresh CCP material against a compacted cold vertical joint.

- b. Plane of Weakness Joints: Cut joints with early entry saws at the locations indicated in the Paving Plan. Cut control joints to 1/4 the depth of the compacted CCP. Saw as soon as possible without causing raveling or other damage to the pavement, but no later than 18 hours after placement.
- c. Seal joints as soon as practicable after completion of the curing period and before opening to traffic with material approved by the Owner

10. Smoothness. Test the finished surface of the CCP with a 10-foot straightedge to ensure that no high or low spots exceed 1/2 inch over 10 feet. Correct high or low spots in pavements that exceed the tolerances by grinding the surface.

11. Opening to Traffic. The CCP may be opened to light traffic (less than 8,000 lbs gross vehicle weight) once it has been fully compacted and curing has been applied. Before using the pavement as a haul road for loaded or unloaded construction equipment vehicles or opening to public traffic, ensure that compressive strength tests show the CCP has developed at least 2000 psi.

f. Quality Control and Quality Assurance.

- 1. Quality Control of materials and processes will be the responsibility of the Contractor.
 - a. The Contractor will develop and provide the Owner with a Quality Control Plan that must, at a minimum:
 - i. Identify the QC Plan Administrator and QC Staff.
 - ii. Provide procedures related to the placement of the concrete such as:
 - 1. Equipment and facilities for placement of concrete.
 - 2. Hot and Cold Weather protection considerations and methods.
 - 3. Preparation of substrate.
 - 4. Transportation of materials.
 - 5. Time limits for placement of concrete.
 - 6. Process for monitoring stability of the concrete temperature during production and placement.
 - 7. Process for monitoring stability of the concrete mixture during production and placement.
 - 8. Process for monitoring effectiveness of consolidation methods.
 - 9. Process for monitoring surface texture and segregation.
 - 10. Ride quality control.
 - 11. Depth checks.
 - 12. Finishing and curing.
 - 13. Jointing.
 - iii. Identify procedures to address Non-Conforming Work.
 - iv. Identify how documentation of the QC Activities and Testing will be provided.

- v. Provide a Corrective Action Plan for Non-Conforming Work
 - b. The QC Plan Administrator and QC Staff must have full authority and responsibility to take all actions necessary for the successful implementation of the QC plan and to stop the work, if necessary.
- 2. Quality Control Testing will be provided by the Contractor as follows:
 - a. The QC Plan Administrator is expected to facilitate Start-Up testing daily at the point of placement as follows:
 - i. The Owner QA and Contractor QC will perform tests for Temperature on the initial load of concrete per ASTM C 1064 delivered to the site.
 - 1. The side by side test results for Temperature must be within 1 degree F of each other
 - 2. If the differences are more than 1 degree F, the Owner will facilitate steps to be taken to determine which of the thermometers is reading incorrectly.
 - ii. Concrete placement may not commence until this testing has verified that the concrete is within specification for temperature.
 - iii. The QC Staff are expected to evaluate changes in Temperature during the transport of the concrete, testing at both the plant and the site as needed to provide concrete meeting these specifications at the point of placement.
 - b. The QC Staff are responsible for testing for the Temperature from samples obtained at intervals identified in the QC Plan.
 - c. The QC staff are expected to cast and test cylinders according to ASTM C 1435 to evaluate the in-place strength of the concrete to be able to support loads as needed and per the QC Plan.
 - d. The QC Plan Administrator is expected to facilitate daily sampling and testing of the Combined Aggregate Blend for the concrete mixture being used that day and provide the Owner both the test results and any adjustments needed for the blends.
 - e. The QC Staff are expected to perform in-place field density tests on the CCP in accordance with ASTM C 1040, direct transmission, as soon as possible, but no later than 30 minutes after completion of rolling.
- 3. Quality Assurance to establish acceptance and payment for the work will be provided by the Owner who will:
 - a. Review and approve all CCP Mix Designs prior to any CCP being placed.
 - b. Perform Proof rolling and in-place density tests on the subgrade and aggregate base.
 - c. Conduct periodic pavement thickness depth checks during placement.
 - d. Perform in-place field density tests on the CCP in accordance with ASTM C 1040, direct transmission, as soon as possible, but no later than 30 minutes after completion of rolling.
 - e. Monitor the adequacy of the finishing techniques, application of the curing compound and the final finished product.
 - f. Visually inspect joint configuration and placement for conformance to the details shown or referenced on the project plans and monitor sawed joints for spalling and cracking.
 - g. Visually inspect the work for damage due to lack of protection both before and after the placement.
 - h. Visually inspect the final concrete surface for texture and for surface defects such as spalling, scaling, cracks, segregation, etc.
 - i. Advise the Contactor as to the time when the concrete is suitable for opening to traffic.

- j. Sample and test the concrete for temperature per ASTM C 1064.
- k. Sample and test the concrete to determine the compressive strength for each placement by testing three (3) cylinders prepared, cured and tested according to ASTM C 1435, ASTM C 31 and ASTM C 39.
 - i. The required compressive strength shall be 4000 psi at age 28 days.
 - ii. A 28-day test shall be the average of three cylinders.

g. Measurement and Payment.

1. Non-Conforming Work Identified During Construction

- a. Prior to consideration for final payment for the completed work, the following
- b. Non-conforming work must be corrected or addressed as follows:
 - i. CCP placed without an approved Mix Design will be rejected, removed and replaced.
 - ii. CCP placed on aggregate base that has become unsuitable during placement and was not corrected by the Contractor will be rejected, removed and replaced or subjected to a payment reduction at the discretion of the Owner.
 - iii. CCP not meeting the required thickness tolerance will be rejected, removed and replaced or subjected to a payment reduction at the discretion of the Owner.
 - iv. CCP placed outside of either the ambient or concrete temperature or evaporation rate limits will be rejected, removed and replaced or subjected to a payment reduction at the discretion of the Owner.
 - v. Areas of the CCP which do not meet the required in place density will be rejected, removed and replaced.
 - vi. Areas of the CCP which exhibit segregation will be rejected, removed and replaced.
 - vii. Areas of the CCP which exhibit inadequate finishing, curing and/or, physical damage due to lack of protection of the work will be rejected, removed and replaced or subjected to a payment reduction at the discretion of the Owner.
 - viii. Areas of the CCP which exhibit spalling, scaling, cracks or insufficient surface texture will be rejected, removed and replaced at the discretion of the Owner.
 - ix. Joints with spalling will be patched as Directed by the Owner.
 - x. Areas of the CCP represented by cylinders not meeting the required compressive strength will be rejected, removed and replaced or, at the discretion of the Owner:
 - 1. Be evaluated by testing at least three (3) cores taken from the pavement in question by the Contractor for compressive strength according to ASTM C 42.
 - a. CCP in question will be considered to have met the strength requirement if the average strength of the cores is at least 3,500 psi and no single core breaks below 3,000 psi.
 - b. CCP for which representative cores do not meet the required compressive strength will be removed and replaced
- c. Any concrete requiring removal and replacement
 - i. Will be to the nearest joint in each direction from the affected area
 - ii. May be replaced with ready mix concrete, adequately tied to the CCP, at the discretion of the Owner.

2. The completed work as described will be paid for at the contract unit price for the following contract items (pay items):

| <u>Pay Item</u> | <u>Pay Unit</u> |
|-----------------------------------|-----------------|
| Compacted Conc Pavt, 9 inch | . Square Yard |

Payment for **Compacted Conc Pavt, 9 inch** will be measured in place to the limits as shown on the plans and includes all material, labor, and equipment necessary to complete the work as described.

3. Non-Conforming Work Identified during the Maintenance and Guarantee Bond period
- a. Joint Sealant that has popped out or does not completely seal the joint shall be removed and replaced.
 - b. Concrete Slabs (defined as a section of concrete bounded by, a longitudinal saw cut joint, a transverse saw cut joint, a construction joint, a curb or an unsupported edge) that exhibit spalling along the joints covering over 30% of the perimeter of the slab will require removal and replacement of the slab with ready mix concrete adequately tied to the CCP.
 - c. Concrete Slabs that exhibit scaling covering over 15 % of the area of the Slab will require removal and replacement of the Slab with ready mix concrete adequately tied to the CCP.
 - d. Concrete Slabs with a single crack will require the crack to be routed and sealed.
 - e. Concrete Slabs with 2 or more cracks will require removal and replacement of the Slab with ready mix concrete adequately tied to the CCP.

CITY OF PONTIAC
 SPECIAL PROVISION
 FOR
TEMPORARY CONSTRUCTION WORK ZONE SIGNS AND BARRICADES

HRC

1 of 1

5/21/2021

a. Description

This work shall consist of furnishing and installing temporary construction work zone signs in accordance with the Michigan Department of Transportation Traffic Standard Plans and Typical and the 2012 Michigan Department of Transportation Standard Specifications for Construction except as modified, herein.

b. Construction

The construction work zone signs shall be removed immediately following the end of construction. Half of the quantity of signs will be retained for payment until such time as the signs are removed from the site.

c. Measurement and Payment

The completed work, as measured, will be paid for at the contract unit price for the following contract item (pay item):

| <u>Pay Item</u> | <u>Pay Unit</u> |
|---|-----------------|
| Barricade, Type III, High Intensity, Double Sided, Furn, Modified | Each |
| Barricade, Type III, High Intensity, Double Sided, Oper, Modified | Each |
| Plastic Drum, Fluorescent, Furn, Modified | Each |
| Plastic Drum, Fluorescent, Oper, Modified | Each |
| Sign, Type B, Temp, Prismatic, Furn, Modified | Square Foot |
| Sign, Type B, Temp, Prismatic, Oper, Modified | Square Foot |
| Channelizing Device, 42 inch, Fluorescent, Furn, Modified | Each |
| Channelizing Device, 42 inch, Fluorescent, Oper, Modified | Each |
| Lighted Arrow, Type C, Furn, Modified | Each |
| Lighted Arrow, Type C, Oper, Modified | Each |
| Sign, Type B, Temp, Prismatic, Special, Furn, Modified | Square Foot |
| Sign, Type B, Temp, Prismatic, Special, Oper, Modified | Square Foot |

Payment for the temporary traffic control devices including signs and barricades listed above shall include all labor, materials, and equipment necessary to install all temporary traffic control devices including signs and barricades per all pertinent guidelines as well as those listed above. All temporary traffic control devices including signs and barricades shall be paid in halves with half of the square footage or each being paid with the nearest pay estimate at time of installation and the other half being paid with a pay estimate nearest the time that all of the temporary traffic control devices have been removed from the site.

CITY OF PONTIAC
SPECIAL PROVISION
FOR
RECONSTRUCTING SPRINKLER SYSTEMS

HRC

Page 1 of 2

May 28, 2021

a. Description.

This work shall be done in accordance with the 2012 Michigan Department of Transportation Standard Specifications for Construction, except as herein provided

b. Materials.

The materials used to reconstruct the sprinkler system(s) shall be of equal or greater quality as originally installed.

c. Construction.

Existing lawn sprinklers shall be relocated to accommodate the proposed construction.

Additional sprinklers not shown on the plans may be encountered in the line of work.

The Contractor shall exercise care in preserving and protecting existing lawn irrigation systems.

All necessary work associated with the relocation, replacement, and reconnection of sprinkler systems shall be as directed by the Engineer.

Where replacement of portions of existing systems is necessary, the various components used for replacement shall match and duplicate the existing materials as closely as practicable.

Sprinkler heads and underground piping shall be relocated, restored, and reconnected immediately following disruption by construction and grading operations.

Any and all sprinkler systems within the project limits, or impacted by the work of this contract, shall be repaired with at least equal quality materials and workmanship, to a functioning condition at least as good as existed prior to work beginning. For the contractor to be reimbursed for such repairs, before any contract work begins, the contractor shall arrange a walk-through with the property owner or designated representative, accompanied by the project engineer or inspector, of each and every adjacent property, to determine and evaluate the existing sprinkler system design (location and types of lines, heads, valves, controllers) and its functionality and integrity. This information will be documented with sketches, drawings, and narratives, by the contractor, to be submitted to and used by the project engineer to verify the need and approve any payment for repairs to the system. No payment shall be made for repairs not deemed necessary and approved by the project engineer as a result of this walk-through and evaluation process. Failure of the contractor to fulfill these requirements shall cause the project engineer to make the repairs and charge the full cost to the contractor as a contract adjustment.

d. Measurement and Payment.

| Pay Item | Pay Unit |
|---|-----------------|
| Sprinkler Head, Relocate, Modified..... | Each |
| Sprinkler Head, Replace, Modified..... | Each |
| Sprinkler Line, Modified..... | Foot |

Payment for Sprinkler items includes equipment, labor, and materials to complete this item as specified above. Relocating and replacing sprinkler heads will be measured as units. Sprinkler line, regardless of size, will be measured in linear feet.

Costs for connecting, testing, and adjusting the completed work will be included in the Contract unit prices for the above items. Contract unit prices for the above sprinkler items shall also include the cost of furnishing all necessary materials and fittings, and for all necessary excavation, backfilling, and disposal of surplus material. All necessary components shall be provided by the Contractor, but those, not a designated contract pay items will not be paid for separately.

#10

RESOLUTION



CITY OF PONTIAC

OFFICIAL MEMORANDUM

Executive Branch

TO: Honorable City Council President Kermit Williams, and City Council Members

FROM: Darin Carrington, Finance Director

CC: Honorable Mayor Deirdre Waterman,

DATE: July 14, 2021

RE: **Resolution to uncommit \$3.2 million in the general fund's committed fund balance, initially committed for the purchase of the Youth Recreation and Enrichment at 825 Golf Road and to transfer \$3.2 million to the Capital Improvement's committed fund balance towards leasehold improvements at the Ewalt Community Center**

In 2017-2018 the City of Pontiac committed \$3.2 million to go towards the costs of a Youth Recreation Center. In July 2021, a request has been submitted to City Council to uncommit the funds in the General Fund slated for the Youth Recreation Center. Additionally, the funds would then be recommitted to the Capital Improvement Fund to be used for renovations and improvements at the Ewalt Community Center at 1460 Perry Street. As such, the following resolution is recommended for your consideration:

Whereas, the Government Standards Accounting Board (GASB) has issued Statement No. 54 establishing a diarchy classifying constraints that govern how a government entity can use amounts reported as fund balance; and

Whereas, City Council is the highest level of decision making authority and has the ability to commit, assign or evaluate existing fund balance classifications and identify the intended uses of committed or assigned funds; and

Whereas, City Council has determined that the funds committed in the general fund, account number 101-000-393.001 in the amount of \$3,200,000 should be uncommitted to unassigned fund balance account number 101-000-390.000; and

Whereas, City Council has determined that a transfer should be made from the General Fund's unassigned funds balance, account number 101-000-390.000 in the amount of \$3,200,000 to the Capital Improvement's Committed Fund Balance Account 445-000-393.001 to be used for leasehold improvements at the Ewalt Community Center at 1460 N. Perry Street.

NOW THEREFORE Be It Resolved that the City Council hereby authorizes the Interim City Clerk to publish a notice in a newspaper of general circulation at least one week before consideration of the proposed transfer of funds from the General Fund's unassigned fund balance account number 101-000-393.001 to the Capital Improvement Fund's committed fund balance account 445-000-393.001.

#11

RESOLUTION



n

Executive Branch

CITY OF PONTIAC

OFFICIAL MEMORANDUM

TO: Honorable City Council President Kermit Williams, and City Council Members

FROM: Darin Carrington, Finance Director

CC: Honorable Mayor Deirdre Waterman

DATE: July 14, 2021

RE: **Resolution to approve a budget amendment for Fiscal Year 2021-22 to allocate a total of \$3.2 million, from the Capital Improvement Fund's Committed Fund to the Capital Improvement Fund account 445-756-971.001 to be used for restoration of the Ewalt Community Center as a Youth Community Center.**

In July 2021 a decision was made by City Council to uncommit the funds in the general fund originally intended for the purchase of property for Youth Recreation Center and to recommit the funds in the Capital Improvement Fund to be used for leasehold improvements at the Ewalt Community Center at 1460 Perry Street.

It is hereby requested that the City Council establish the budgeted line item for the leasehold improvements at the Ewalt Community Center in the capital improvement budget

As such, the following resolution is recommended for your consideration:

Whereas, the City of Pontiac timely approved the 2021-2022 budget on June 24, 2021 and;

Whereas, on the City Council has previously requested the desire to transfer funds \$3.2 of committed funds from the General Fund to the Capital Improvement Fund; and

Whereas, the Administration is proposing to the City Council to increase the appropriations for the current Fiscal Year 2021-2022 for the leasehold improvements at the Ewalt Community Center for the amount of \$3.2 million to account 445-756-971.001; and

Whereas, the increased appropriations will not cause the fund balance in the Capital Improvements Funds fund to go below the policy mandated thresholds and;

NOW THEREFORE be resolved that the City Council hereby approves the amendment for the fiscal year 2021-2022 as requested by the Administration for account 445-756-971.001-Leasehold Improvements Ewalt Center in the amount of \$3.2 million.

This item cannot be approved until after the resolution to authorize the City Clerk to publish the notice of the budget amendment has been approved and one week after the publication of the notice. It takes 5 votes to approve a budget amendment.

#12

RESOLUTION



CITY OF PONTIAC

OFFICIAL MEMORANDUM

Executive Branch

TO: Honorable City Council President Kermit Williams, and City Council Members

FROM: Darin Carrington, Finance Director

CC: Honorable Mayor Deirdre Waterman, Abdul Sieddiqui, Al Cooley

DATE: July 14, 2021

RE: **Resolution to approve a budget amendment for fiscal year 2021-2022 to allocate a total \$34,822,000 for road construction and engineering services broken out as follows: \$1.8 million for Major Streets road construction mill and fill projects, \$1.2 million for Major Streets projects supervision, \$120,000 for Local Streets rehabilitation projects, \$250,000 for general fund CDBG projects, and \$450,000 for contracted construction services to repair downtown sidewalks, \$100,000 for Collier Road Landfill projects supervision and \$300,000 for construction to repair damaged stormwater drainage channels at Collier Road Landfill 202-443-816.000.**

As such, the following resolution is recommended for your consideration:

Whereas, the City of Pontiac timely approved the 2021-2022 budget on June 24, 2021 and;

Whereas, the Administration has reviewed the department of public works requirements for road construction, and preliminary engineering and construction engineering services for the fiscal year 2021-2022; and

Whereas, the Administration is proposing to the City Council to increase the appropriations for the current fiscal year 2021-2022 for road construction, preliminary engineering and construction engineering services for Major Streets projects supervision in the amount of \$1.2 Million to account 202-463-806.000, Major Streets road construction for mill and fill projects, in the amount of \$1.8 Million to account 202-463-974.074; Local Streets engineering services for local streets rehabilitation projects in the amount of \$120,000 to account 203-463-806.000; General Fund engineering services for CDBG projects in the amount of \$250,000 to account 101-447-806.000; and Major Streets contracted services for downtown sidewalks in the amount of \$450,000 to account 202-443-816.000, Collier Road Landfill projects oversight in the amount of \$100,000 to account 226-528-806.000; Collier Road Landfill stormwater drainage channels construction in the amount of \$300,000 to account 226-528-816.000.

Whereas, the increased appropriations will not cause the fund balance in the Major Streets, Local Streets, Sanitation Fund and General Fund funds to go below the policy mandated thresholds and;

NOW THEREFORE be resolved that the City Council hereby approves the appropriation amendment for the fiscal year 2021-2022 as requested by the Mayor and Department of Public Works for account 202-463-806.000 in the amount of \$1.2 million, for account 202-463-974.074 in the amount of \$1.8 million, for account 203-463-806.000 in the amount of \$120,000, for account 101-447-806.000 in the amount of \$250,000, and for account 202-443-816.000 in the amount of \$450,000, for account 226-528-806.000 in the amount of \$100,000 and for account 226-528-816.000 in the amount of \$300,000

. This item cannot be approved until after the resolution to authorize the City Clerk to publish the notice of the budget amendment has been approved and one week after the publication of the notice. It takes 5 votes to approve a budget amendment.

#13

RESOLUTION



CITY OF PONTIAC

OFFICIAL MEMORANDUM

Executive Branch

TO: Honorable City Council President Williams and City Council Members

FROM: Abdul Siddiqui

DATE: July 20, 2021

RE: **Budget Amendment for Major Streets, Local Streets and General Fund**

With the recently adopted budget for Fiscal Year 2021-22, several cuts were made to the Mayor's Recommended Budget in the areas of road construction and engineering services. These cuts will greatly hamper the Department's ability to carry out on needed road projects for both local and major streets.

With the current funding levels in the FY22 budget, the city cannot afford to provide construction engineering oversight to the construction projects, so they will have to be halted or postponed. Design for future projects will also have to be cut back, causing projects to be delayed. It is imperative that in order to move forward with much needed projects that the City Council re-consider the dollar amounts allocated for FY22 and consider a budget amendment.

Following are some of the impacts to infrastructure projects given the reduced funding level in the FY22 Budget:

- Halting the CDBG Sidewalk Projects that are proposed for Fall 2021 (**Districts 1, 2, 6, 7**) and Spring 2022 (**Districts 2, 3, 4, 5, 6**). Other CDBG projects such as the reconstruction of senior center parking lots will also be halted. This is due to lack of funds for construction engineering oversight due to the reduction of **\$250,000 in 101-447-806.000**. Construction engineering and oversight for these projects is something that could be brought in-house if staffing is approved. The budget proposed by Council for that account is only sufficient for miscellaneous engineering tasks.
- Eliminating the proposed Multi-Road Mill and Fill project from the Major Street Fund – 202 due to the reduction of **\$1.8 Million in 202-463-974.074**. This project was planned for Spring 2022 to rehabilitate asphalt pavement on multiple roads throughout the City. Some of the roads being considered for the project are:
 - Paddock (**Districts 1, 6, 7**)
 - Giddings (**District 5**)
 - Franklin Blvd (**District 1**)
- Halting almost all major roads projects due to the reduction of **\$1.2 Million in 202-463-806.000**. There is insufficient funding for construction engineering and oversight as well as for design of future projects. Construction projects impacted will include the concrete pavement repairs at Walton Blvd (**District 4**), asphalt overlay of W Columbia (**Districts 3, 4**), modernization of signals on Orchard Lake

(Districts 1, 2), and reconstruction of Mill St **(District 1)**. Projects under design that will be impacted include concrete joint repairs on Baldwin, Telegraph, and Elizabeth Lake **(Districts 2 and 4)** and modernization of signals on Walton Blvd **(Districts 4, 5)**. We may be able to do the construction engineering in-house for one of these projects if staffing is approved.

- Reducing the amount of work to be done with the local roads resurfacing project in Fall 2021 due to reduction of **\$120,000 in 203-463-806.000**. This will result in reduced amount of construction engineering and oversight services. These services for this project could be brought in-house if staffing is approved. The following streets are being resurfaced with this project and some of them will have to be cut from the project as a result of the reduced engineering services budget:
 - Cherry Hill, Starlight, Fairmount **(District 3)**
 - Bynan, Gambrell, Grandville **(District 5)**
 - Granada and Omar **(District 6)**
- City will likely be penalized by the Michigan Department of Environment, Great Lakes, and Energy (EGLE) for failing to repair stormwater drainage channels at the Collier Road Landfill due to reductions of **\$100,000 in 226-528-806.000 and \$300,000 in 226-528-816.000**. There are insufficient construction funds and engineering services funds for that work to occur.

Note the reason the requested engineering services budgets seem so high this year is because the budget has been organized differently. Previously, the engineering services costs associated with specific projects were rolled into the construction accounts for those projects, making it difficult to determine how much the City was spending in engineering services. Only miscellaneous engineering costs were accounted for in the engineering services accounts. Going forward, we are proposing to separate all engineering services costs into their respective engineering services accounts for the sake of transparency.

Also bear in mind that the major and local street funds (202 and 203) cannot be used for anything other than road construction and maintenance. Cutting funding from those funds does not provide any benefit, particularly since we are careful to maintain at least a 10% fund balance at all times. We are required to use these funds for road projects and delays in using the funds timely provides no benefit and can actually cause repair costs to increase.

It is important to realize that removing dollars from the budget significantly impacts projects that had been scheduled for the year. I am requesting that the City Council reconsider and increase the funding levels for FY22 so that the above mentioned projects are able to go forward. Without this funding, the City is placed at a disadvantage for needed repairs and maintenance of the City's road infrastructure.

Attachment

Mill St (To be reconstructed)



Vanguard Dr (To be reconstructed)



W Columbia (To be resurfaced with asphalt)



Local Roads: Cherry Hill, Starlite, Bynan, Gambrell, Grandville, Granada, Omar (To be resurfaced with asphalt)











#14

RESOLUTION



n

Executive Branch

CITY OF PONTIAC

OFFICIAL MEMORANDUM

TO: Honorable City Council President Kermit Williams, and City Council Members

FROM: Darin Carrington, Finance Director

CC: Honorable Mayor Deirdre Waterman

DATE: July 14, 2021

RE: **Resolution to approve a budget amendment for Fiscal Year 2021-22 allocate an additional \$352,635 to the Overtime budget for public safety services**

The City Council recently adopted the Fiscal Year 2021-22 budget which included certain appropriations for public safety services provided by the Oakland County Sheriff. Included in this budget were additional funds to provide increased services for a traffic enforcement unit and additional sheriff deputies. Part of these increases would be targeted towards providing additional resources towards community policing to help address some of the public safety concerns in the City's residential neighborhoods.

The adopted budget also decreased the requested Overtime budget by approximately \$352,000. Based on the operational plans provided by the Sheriff's office, this reduction in Overtime will impact on the ability for the City to receive the full increased services as originally planned. In order to avoid this impact on service and to fully implement the planned increase in deputies, the Administration is requesting a budget amendment to increase the Overtime budget for FY22.

As such, the following resolution is recommended for your consideration:

Whereas, the City of Pontiac timely approved the 2021-2022 budget on June 24, 2021 and;

Whereas, the FY 2021-22 budget provided increased funding for public safety services from the Oakland County Sheriff; and

Whereas, the FY 2021-22 budget had a decrease in the Overtime budget; and

Whereas, the City wants to implement the full increase in deputies and public safety services as planned;

NOW THEREFORE be resolved that the City Council hereby approves the amendment for the fiscal year 2021-2022 for account 101-301-818.069-Professional Services-Oakland County Sheriff OT in the amount of \$352,635.

This item cannot be approved until after the resolution to authorize the City Clerk to publish the notice of the budget amendment has been approved and one week after the publication of the notice. It takes 5 votes to approve a budget amendment.

#15

ORDINANCE

Ordinance No. XXXX

AN ORDINANCE TO AMEND THE CITY OF PONTIAC GENERAL EMPLOYEES' RETIREMENT SYSTEM TO CLARIFY ASSET DISTRIBUTION UPON TERMINATION.

The City of Pontiac ordains:

Section 1. Amendments.

That the City of Pontiac General Employees' Retirement System ("GERS") is hereby amended as follows:

a. Paragraph (b) of Section 36A [92-46A] of the GERS is amended to read as follows:

(b) The Excess Assets resulting from erroneous actuarial computation shall be transferred as follows:

(i) \$8,000,000.00 shall be transferred to an account established by the City for the purpose of holding funds which shall be utilized to make the one-time payments described in and required by Section 11 of the Settlement Agreement.

(ii) The remaining Excess Assets shall be transferred to a voluntary employees' beneficiary association under Code §501(c)(9) (that has received a favorable determination letter as to the tax-exempt status of such trust under Code section 501(c)(9)) established or to be established by the City to fund retiree health benefits for certain City retirees that are subject to the Settlement Agreement.

Section 2. Severability.

If any section, or provision of this Ordinance shall be declared to be unconstitutional, void, illegal, or ineffective by any Court of competent jurisdiction, such section, clause or provision declared to be unconstitutional, void or illegal shall thereby cease to be a part of this Ordinance, but the remainder of the Ordinance shall stand and be in full force and effect.

Section 3. Repealer.

All Ordinances or parts of Ordinances in conflict herewith are hereby repealed only to the extent necessary to give this Ordinance full force and effect.

Section 4. Publication.

The Clerk shall publish this Ordinance in a newspaper of general circulation.

Section 5. Effective Date.

This Ordinance shall be effective 10 days after adoption by the City Council.

I hereby certify that the foregoing is a true copy of the Ordinance as passed by the City Council of the City of Pontiac at a regular Council Meeting held in the City Council Chambers in said City on the _____ day of July, 2021.

Garland S. Doyle, Interim City Clerk

37903981.1/071371.00075

#16

RESOLUTION



CITY OF PONTIAC

OFFICIAL MEMORANDUM

Executive Branch

TO: Honorable City Council President Williams and City Council Members

FROM: Darin Carrington, Finance Director

DATE: July 22, 2021

RE: Request for Actuarial Study for Extension of Supplemental Pension Payment for GERS Retirees

Currently, General Employees Retirement System (GERS) retirees receive a supplemental pension payment in the amount of \$400 per month. The Supplemental Payment is set to expire on August 31, 2021. The City has been working with the newly established VEBA in getting the health care benefits for eligible retirees and other individuals. In order to avoid the Supplemental Payment ending before the VEBA is able to provide the planned health care benefits, we would like to extend the Supplemental Payment beyond the August 31st expiration date.

In order to extend the Supplemental Payment, an actuarial study must be done to determine the costs of this extension. We are submitting the attached resolution to Council in order to request the GERS board to have the actuary prepare this required actuarial report. The VEBA is expected to begin providing health care benefits in the Fall and the expectation is that the Supplemental Payment will end at that time. The actuarial report will be done based on the extension being done through December 31, 2021 although we expect that the Supplemental Payments can be ended sooner than that date.

City of Pontiac

PONTIAC CITY COUNCIL

At a regular meeting of the Pontiac City Council (“City Council”) held on _____, 2021.

WHEREAS, City’s GERS retirees currently receive a \$400 supplemental pension payment (“Supplemental Payment”) and this payment is set to expire on August 31, 2021. The City desires to determine the costs for extending the Supplemental Payment for a period to no longer than December 31, 2021;

WHEREAS, MCL §38.1140h(5) requires that a supplemental actuarial analysis concerning the costs of extending the Supplemental Benefit be conducted by the GERS system’s actuary prior to extension of the Supplemental Benefit;

WHEREAS, MCL §38.1140h(5) requires that any supplemental actuarial analysis be paid for by the City (not the retirement system); and

WHEREAS, the City desires to have a supplemental actuarial analysis evaluating the financial viability of the extending the Supplemental Benefit be conducted and adopts the following resolutions:

RESOLVED, that the Reestablished GERS’s Board of Trustees are directed to have the system’s actuary conduct the supplemental actuarial analysis required by MCL §38.1140h(5) for purposes of extending the Supplemental Payment; and

FURTHER RESOLVED, that the City shall pay for the cost of the supplemental actuarial analysis.

#17

RESOLUTION

**Amendment No. 1
to the
CITY OF PONTIAC VEBA DECLARATORY TRUST AGREEMENT**

This Amendment to the City of Pontiac VEBA Declaratory Trust Agreement (the "Amendment") is adopted by the City of Pontiac, Michigan (the "City") and the City of Pontiac VEBA Trust (the "Trust"), effective [], 2021.

WHEREAS, the City established the Trust on March 23, 2020;

WHEREAS, the Internal Revenue Service issued a determination letter on August 10, 2020, indicating that the Trust is exempt from federal income taxation under Code §501(c)(9) effective March 23, 2020;

WHEREAS, the City entered into a settlement agreement with a class of retirees related to City funding of retiree health benefits in *City of Pontiac Retired Employees Association et. al. v. Schimmel et. al*, Docket #64-2, Case No. 2:12-cv-12830-AC-PJK dated March 30, 2018 (United States District Court Eastern District of Michigan), which was given final approval by the court on November 19, 2018 (the "Settlement Agreement");

WHEREAS, Article 10 of the City of Pontiac VEBA Declaratory Trust Agreement ("Trust Agreement") generally permits the provisions of such trust agreement to be amended to the extent such amendment is not inconsistent with the Settlement Agreement and does not adversely affect the tax exempt status of the Trust;

WHEREAS, this Amendment has been negotiated between the City of Pontiac Retired Employees Association and the City;

WHEREAS, on [], 2021, the Pontiac City Council approved a resolution authorizing the adoption of this Amendment in order to effectuate the terms of Settlement Agreement; and

WHEREAS, on [], 2021 the Board of Trustees of Trust unanimously approved a resolution authorizing the adoption of this Amendment in order to effectuate the terms of Settlement Agreement.

NOW THEREFORE, the Parties agree and declare that the Trust Agreement is hereby amended as follows:

1. Section 1.10 of the Trust Agreement is amended in its entirety to read as follows:

1.10 "Excess Assets" means an amount equal to (1) the assets held within the GERS on the GERS Approved Termination Date which exceed 130% the GERS pension liabilities on that date, minus (2) \$8,000,000.00.

2. Section 1.14 of the Trust Agreement is amended in its entirety to read as follows:

1.14 “GERS Approved Termination Date” means March 31, 2021.

3. Section 3.4A of the Trust Agreement is added in its entirety to read as follows:

3.4A Contribution from Unutilized Opt-Out Funding. The City maintains (or will maintain) an account which holds City funds which shall be utilized to make the one-time payments described in and required by Section 11 of the Settlement Agreement. If funds remain in such City account upon the City’s payment of the last possible one-time payment required by Section 11 of the Settlement Agreement, then the City shall transfer such remaining funds into the Trust Fund.

IN WITNESS WHEREOF, the Parties have caused this instrument to be signed and/or executed by duly authorized officers of the City of Pontiac VEBA Trust, and the City.

City of Pontiac VEBA Trust

By: Claudia Filler
Its: Chairperson

Dated: _____, 2021

City of Pontiac

By: Dr. Deirdre Waterman
Its: Mayor

Dated: _____, 2021

#18

RESOLUTION

**Amendment No. 1
to the
CITY OF PONTIAC
RETIREE GROUP HEALTH AND INSURANCE PLAN**

This Amendment to the City of Pontiac Retiree Group Health and Insurance Plan (the "Amendment") is adopted by the City of Pontiac, Michigan (the "City"), effective [], 2021.

WHEREAS, the City established the City of Pontiac VEBA Trust (the "Trust") on March 23, 2020;

WHEREAS, the Trust, when combined with the City of Pontiac Retiree Group Health and Insurance Plan (the "Plan") constitutes a voluntary employees' beneficiary association and conforms with the requirements of Internal Revenue Code section 501(c)(9) and its implementing regulations;

WHEREAS, the Internal Revenue Service issued a determination letter on August 10, 2020, indicating that the Trust is exempt from federal income taxation under Code §501(c)(9) effective March 23, 2020;

WHEREAS, the City entered into a settlement agreement with a class of retirees related to City funding of retiree health benefits in *City of Pontiac Retired Employees Association et. al. v. Schimmel et. al*, Docket #64-2, Case No. 2:12-cv-12830-AC-PJK dated March 30, 2018 (United States District Court Eastern District of Michigan), which was given final approval by the court on November 19, 2018 (the "Settlement Agreement");

WHEREAS, Section 9.1 of the Plan generally permits the City to amend or terminate the Plan at any time to the extent not inconsistent with the terms of the Settlement Agreement;

WHEREAS, on [], 2021, the Pontiac City Council approved a resolution authorizing the adoption of this Amendment in order to effectuate the terms of Settlement Agreement; and

NOW THEREFORE, the City declares that the Plan is hereby amended as follows:

1. Section 1.2 of the Plan is amended in its entirety to read as follows:

1.2 "**Administrator**" or "**Plan Administrator**" means BeneSys, Inc.

2. Section 1.15 of the Plan is amended in its entirety to read as follows:

1.15 "**GERS Approved Termination Date**" means March 31, 2021.

3. Section 2.1(a) of the Plan is amended in its entirety to read as follows:

(a) Retiree Coverage. A Retiree shall be eligible to participate in the Component Benefit Programs pursuant to the terms, conditions, and limitations set forth in the

Settlement Agreement and the Component Benefit Programs. A Retiree who elects to receive the one-time payment described in Section 11 of the Settlement Agreement shall be deemed to have irrevocably opted out of coverage under the Plan for himself/herself and his/her Dependents and they shall not be eligible to participate in the Plan. Some of the Component Benefit Programs may require the Retiree to make an annual election to enroll for coverage. The details of such annual elections are described in the underlying documents. In certain circumstances, enrollment may occur outside the open enrollment period.

4. Section 2.2 of the Plan is amended in its entirety to read as follows:

2.2 Election Periods.

(a) Initial Election Period. A Retiree must affirmatively elect to receive coverage under the Plan within the later of (1) the 30-day period immediately prior to meeting the eligibility requirements set forth in Section 2.1; or (2) the initial enrollment period established by the Administrator in conjunction with the initial commencement of the Plan's operations.

(b) Open Enrollment / Election Period. A Retiree who wishes to make an election change may do so only during the open enrollment / election period. However, an election change may be made before the open enrollment/election period if a special enrollment event occurs which legally requires mid-year enrollment pursuant to the terms of the underlying Component Benefit Program documents. The change in election request must be timely submitted. Please see the underlying Component Benefit Programs for information related to any permissible mid-year special enrollment rights.

5. Section 2.3 of the Plan is amended in its entirety to read as follows:

2.3 Date of Participation. Unless otherwise provided in the Component Benefit Programs, and as long as the Retiree has timely and properly elected coverage pursuant to Section 2.2, a Retiree will become a Participant on the date the Retiree becomes eligible to participate pursuant to Section 2.1 with respect to a particular Component Benefit Program

6. Section 5.8(b) of the Plan is amended in its entirety to read as follows:

(b) Notice to the Plan Administrator must be made in writing and must be mailed or hand-delivered to:

BeneSys, Inc.
700 Tower Drive, Suite 300
Troy, Michigan 48098

Oral notice or electronic notice (by e-mail or facsimile) is not acceptable. If mailed, the notice must be postmarked no later than the deadline described below. If hand-delivered, notice must be received by the individual at the address above no later than the deadline described below.

Adopted this _____ day of _____ 2021

City of Pontiac, Michigan

DRAFT 7-20-21

By: _____
Dr. Deirdre Waterman, Mayor

37904389.1/071371.00075
07/20/21

#19

RESOLUTION



CITY OF PONTIAC
OFFICIAL MEMORANDUM
Executive Branch

TO: Honorable City Council President Williams and City Council Members

FROM: Mayor Deirdre Waterman

DATE: July 22, 2021

RE: **Status of Plan to Restore Healthcare Benefits and Discussion**

The week's long awaited approval from the IRS means that the City of Pontiac (COP) can finally set in motion the processes that will restore city-funded healthcare benefits to all eligible COP retirees. This has been a long journey that began in 2012 when the Emergency manager terminated retiree healthcare benefits during the city's financial crisis.

The IRS determination letter that was received, marks the culmination of the efforts to resolve the litigation that CPREA brought against the Emergency manager. As I became Mayor and "inherited" this litigation, I set out to resolve it. Leading a COP team of negotiators that worked through nearly two years of mediation that involved two different court-ordered mediators until we reached the terms of the Settlement Agreement (SA) that was finally approved by the IRS last week.

This Settlement Agreement is historic since we understand it is unique in its complexity. Pontiac appears to be the first city that has received approval to use this novel approach to reinstate retiree healthcare. The Settlement Agreement mandates the creation of a new "General Employees Retirement System (GERS)" which will be generally governed under the identical process and format as is provided under the current GERS. Extra assets in GERS will be transferred to a retiree health trust fund (VEBA) which will be managed by an independent board of trustees comprised of local officials, retirees, experts, and a consultant. The VEBA will help administer the city-funded health insurance benefits for the remainder of eligible retirees lives and the lives of eligible spouses, if applicable. The VEBA has been meeting regularly to establish the methodology by which they can provide retiree healthcare coverage.

By the resolution of the city council, when healthcare benefits are restored, the \$400.00 monthly increase in pension benefits will be terminated simultaneously. However, now that our plan to create a new VEBA has received IRS approval, I am bringing a proposal for a new initiative to city council that will provide increased monthly pension benefits to all retirees now eligible to receive a COP pension.

City of Pontiac

PONTIAC CITY COUNCIL

At a regular meeting of the Pontiac City Council ("City Council") held on July ____, 2021.

WHEREAS, the City desires to further explore a proposal to provide certain members of the Reestablished GERS and PFRS with a \$400.00 monthly enhanced retirement benefit ("Enhanced Benefit");

WHEREAS, MCL §38.1140h(5) requires that a supplemental actuarial analysis concerning the costs of implementing the Enhanced Benefit be conducted by the applicable retirement system's actuary prior to adoption of the Enhanced Benefit;

WHEREAS, MCL §38.1140h(5) requires that any supplemental actuarial analysis be paid for by the City (not the retirement systems); and

WHEREAS, the City desires to have a supplemental actuarial analysis evaluating the financial viability of the Enhanced Benefit conducted for both the Reestablished GERS and the PFRS and adopts the following resolutions:

RESOLVED, that the Reestablished GERS's Board of Trustees are directed to have the system's actuary conduct the supplemental actuarial analysis required by MCL §38.1140h(5);

FURTHER RESOLVED; that the PFRS's Board of Trustees are directed to have the system's actuary conduct the supplemental actuarial analysis required by MCL §38.1140h(5); and

FURTHER RESOLVED, that the City shall pay for the cost of such supplemental actuarial analysis.

City of Pontiac – Enhanced Benefit Proposal

April 14, 2021

Background

- Current Mayor of Pontiac, Michigan – Dr. Deirdre Waterman.
- The City of Pontiac pension liability as of year end 2019 was \$256.3 million.
- The liability has been consistently over funded by 30%. That is, the assets set aside by the City of Pontiac for the pension liability was \$333.2 million as of year end 2019.
- The City of Pontiac has seen an average historical investment rate of return of 7%.
- Under the guidance of Mayor Waterman, an Actuarial analysis was conducted and a proposal was made for a monthly benefit enhancement to be provided to eligible retirees. This benefit would be paid for with these excess pension funds. A summary of this analysis and the proposed enhanced benefit are provided in this presentation.

Proposal

- The proposal is to use the excess assets ($\$333.2 - 256.3 = \76.9 million) to provide eligible retirees a monthly benefit enhancement (completely independent of any pension benefit owed) of \$400 per month. This would be paid in perpetuity unless a major change in the market results in the City of Pontiac's historical 5 year average investment rate of return (trigger) to fall to or below 6.0%.

Proposal Contd.

- The enhanced benefit would be reduced if the 5 year average historical investment rate of return (trigger) falls to or below 6%. The enhanced benefit will stop if the trigger falls to or below 4%.
- Historically, the trigger has averaged greater than 7%.
- The enhanced benefit as well as the trigger are calculated such that the cost of this benefit at each aggregate investment scenario should be cost neutral to the city.

Proposal Contd.

Theoretical Reduction to Enhanced Benefit Based on Rate of Return Trigger

| 5-Year Average Rate of Return (Trigger) | Cumulative % Reduction to Original Enhanced Benefit | Enhanced Benefit |
|---|---|------------------|
| 0.00% | | \$400 |
| 10.00% | 10.00% | \$360 |
| 20.00% | 20.00% | \$320 |
| 30.00% | 30.00% | \$280 |
| 40.00% | 40.00% | \$240 |
| 52.00% | 52.00% | \$192 |
| 64.00% | 64.00% | \$144 |
| 76.00% | 76.00% | \$96 |
| 88.00% | 88.00% | \$48 |
| 100.00% | 100.00% | \$0 |

City of Pontiac | 47450 Woodward Avenue, Pontiac, Michigan 48342 | 248.758.3000
 City Hall Hours: Monday - Friday 8:00 a.m. to 5:00 p.m.
webmaster@pontiac.mi.us

Key Notes

- The City of Pontiac and Mayor Waterman are concerned about the retiree's financial well-being and would like to use the excess assets available to provide an additional \$400 enhanced benefit to eligible retirees.
- The option to provide this enhanced benefit is in part related to the investment strategy that the City of Pontiac and Mayor Waterman have taken and continue to take.
- The enhanced benefit would continue in perpetuity unless a drastic change in the market causes a major change in the investment landscape for the City of Pontiac.

Caveats

- Census data and pension asset information was provided by the City of Pontiac. The retiree census has changed from last year. Changes in the census will have significant impacts on the analysis herein.
- The results mentioned in this memorandum are only as good as the underlying data and assumptions. If any of the underlying data is determined to be flawed or inaccurate, then the findings described herein may likewise be flawed or inaccurate.
- The future investment rates of return (or trigger) will have significant impact on the results of the actuarial enhanced benefit analysis.
- The summary in this communication is intended for the addressee only and may be confidential and/or legally privileged.

#20

RESOLUTION



CITY OF PONTIAC

OFFICIAL MEMORANDUM

Executive Branch

TO: Honorable City Council President Williams and City Council Members

FROM: Mayor Deirdre Waterman

DATE: July 22, 2021

RE: **Resolution to Approve Mayor's Appointment of Mark Holland as Deputy Mayor**

In accordance with Article 4.103 of the City Charter, it is my honor and privilege to submit the below resolution to approve the appointment of Mr. Mark Holland to the position of Deputy Mayor.

As you know, Mr. Holland is a life-long resident of Pontiac and brings years of valuable experience to this position. Mr. Holland served on the City Council for four years having been elected by the citizens of District 5. Mr. Holland has continued to serve this City as a strong advocate for a number of important issues including youth and recreation. Additionally, Mr. Holland brings years of valuable work experience from the private sector.

Pending no objection, the following resolution is presented for your consideration:

WHEREAS, pursuant to City Charter Section 4.106 the Mayor has the authority to appoint a Deputy Mayor; and

WHEREAS, the Deputy Mayor position is currently not filled; and

WHEREAS, the Mayor has introduced the appointment of Mr. Holland as Deputy Mayor; and

WHEREAS, Mr. Holland is imminently qualified to fulfill the position of Deputy Mayor;

NOW THEREFORE, BE IT RESOLVED the City Council hereby approves of the appointment of Mr. Mark Holland as the Deputy Mayor for the City of Pontiac

Attachment



MARK E. HOLLAND

OBJECTIVE

I want to contribute to an organization that can use an experienced problem-solver and decision-maker who offers strong communication and organizational skills along with a proven ability to motivate, persuade, and inspire others.

EXPERIENCE

City of Pontiac 2014-2018

Councilman of District 5, regularly and thoroughly prepares for each City Council meeting, acts like a liaison between the City and general public, reviews and approves an annual budget, reviews Capital improvement programs for the City, Served on the T.I.F.A and Brownfield Board, Finance Committee, Chair of Real Estate Sub Committee and Law Sub Committee.

Dean Transportation 2014-2018

Transportation Consultant duties include maintain accurate transportation scheduling for Walled Lake School District.

Hollandmark Service Group 2012- 2018

Responsible for landscaping, billing, payroll, managing employees, maintaining vehicles, creating and maintaining clientele as well as advertising

Comerica bank 1995- 2012

Assistant manager of Data Center Operations Print Division, managing over 15 employees, charge with managing customer savings and checking accounts

LesMark Transport 2002-2010

Transporting children to and from school of choice, managing over 20 employees, creating and scheduling pick up and drop offs routes, managing billing, payroll, purchasing and maintaining vehicles and scheduling employees training.

EDUCATION

Pontiac Northern High School Diploma- General Courses.
Oakland Community College- General Courses
America Institute of Banking- Banking Courses
University of Phoenix- Banking Administration

SUMMARY OF QUALIFICATIONS

Proficient with popular software programs including Microsoft Word, Excel, Access and PowerPoint, Jes 2 command, CA-7, 4100 IBM Printer, 3900 IBM Computer and Printer, Certified CDL and DOT Endorsement, CDL Endorsement License, Budget Specialist and Spreadsheet Analyst.

#21

**COMMUNICATION
FROM THE
MAYOR**

**City of Pontiac
Executive Office of the Mayor**

**PROCLAMATION
DECLARING WWII GREATEST GENERATION DAY**

- WHEREAS,** on July 8, 2021 the City of Pontiac will participate in an event at the Oakland County International Airport, main terminal and;
- WHEREAS,** this event is being hosted by the Commemorative Air Force (CAF) and the American Rosie the Riveter Association (ARRA) to reunite the "Diamond Lil" a B-24 war plane with persons that built and/or flew the airplanes and;
- WHEREAS,** the CAF's historic flyable B-24 Liberator Bomber, "Diamond Lil" will be reunited with living members of the WWII Greatest Generation and;
- WHEREAS,** these men and women played a direct part in the many victories that Diamond Lil represents and;
- WHEREAS,** attending this historic event will be WWII Veterans that flew missions of which included WWII D-Day invasion troops and the Tuskegee fighter pilots that escorted them, "Rosie the Riveter", women who built the B-24 bombers at Willow Run, home front laborers who build housing for the influx of workers and the Home Front volunteers who supported the war with necessary items such as blood drives and scrap metal and;
- WHEREAS,** for those of the Greatest Generation, September 2, 1945 represented the culmination of 1,336 days of arduous and demanding sacrifice. Over 400,000 Americans made the ultimate sacrifice during World War II and;
- WHEREAS,** the City of Pontiac can't let this day go by without noting, thanking and honoring World War II veterans and all who sacrificed to bring freedom to countless persons all over the world. This truly was the Greatest Generation,"

NOW THEREFORE BE IT RESOLVED as Mayor of Pontiac, and on behalf of the residents on Pontiac, affixed by my signature on this 8th day of July, I hereby declare July 8, 2021 as "WWII Greatest Generation Day" to honor these amazing Americans

Dr. Deirdre Waterman
Mayor