

High Inductance Molded Inductor AWTC0660A

Product features

- Soft saturation. Low EMI.
- High current, low DCR, high efficiency.
- Current range from 3.8A to 24A
- Inductance range from 1.0μH to 22μH.
- Very low acoustic noise and very low leakage flux noise.
- High reliability.
- 100% Lead (Pb)-Free and RoHS compliant.
- Operating temperature -55~+125°C (Including self - temperature rise)

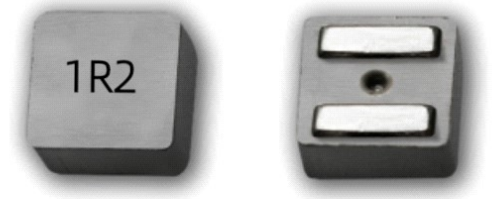

Applications

- Note PC power system, incl. IMVP-6
- DC/DC converter, Electric pumps, motor control and auxiliaries.
- LED lighting/Battery management systems/Powertrain control module...

Dimensions (Unit: mm)

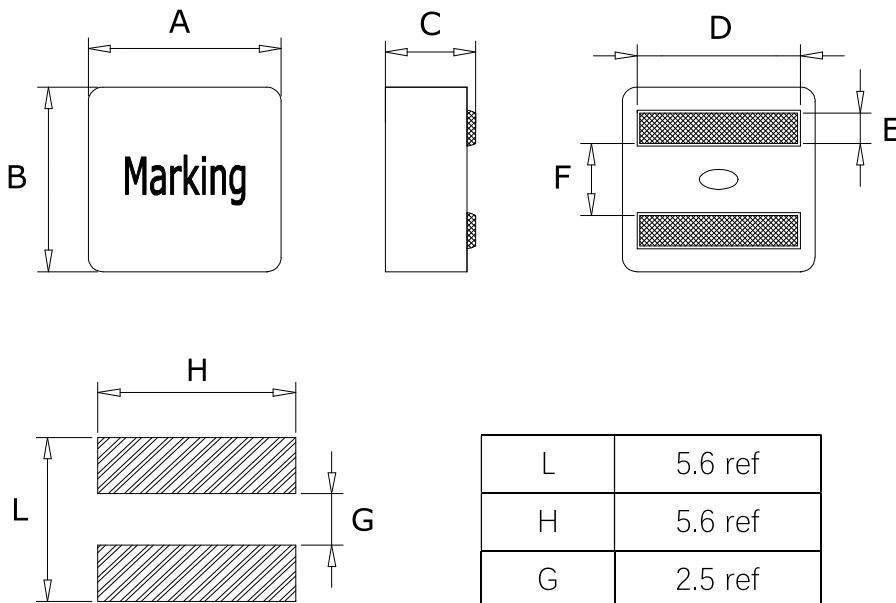

Recommend Land Pattern

Unit: mm

Specifications

Part Number	L0 (μH) $\pm 20\%$	DCR ($\text{m}\Omega$) MAX	Isat (A)		Irms (A)Typ	
			MAX	TYP	20°C rise	40°C rise
AWTC0660A-1R0M	1.0	4.4	24.0	19.0	16.0	21.0
AWTC0660A-1R5M	1.5	6.1	20.0	15.0	13.5	17.5
AWTC0660A-2R2M	2.2	8.1	16.5	12.5	11.0	14.0
AWTC0660A-3R3M	3.3	12.3	13.0	11.0	9.0	12.0
AWTC0660A-4R7M	4.7	14.4	10.5	9.3	8.5	11.0
AWTC0660A-5R6M	5.6	15.9	9.9	8.7	7.6	10.0
AWTC0660A-6R8M	6.8	20.8	9.2	8.1	7.0	9.0
AWTC0660A-8R2M	8.2	26.4	8.4	8	6	8
AWTC0660A-100M	10	29.82	7.6	6.8	5	7
AWTC0660A-150M	15	43.75	5.8	5	4.5	6
AWTC0660A-220M	22	60.63	5.6	4.8	3.8	5

Notes:

1. Test frequency: L : 100KHz /0.1V;
2. All test in 25 °C temperature.
3. Heating Rating Current (Irms) will cause the coil temperature rise of 40°C approximately (Δt);
4. Saturation Current (Isat) will cause L0 to drop 30% approximately.
5. The part temperature (ambient + temp rise) should not exceed 125°C under the worst-case operating condition. Circuit design, component, PCB trace size and thickness airflow and other cooling provisions all could affect the part temperature. Part temperature should be verified in the end application.
6. Special inquiries besides the above commonly used types can be met on your requirement.

Structure and Components

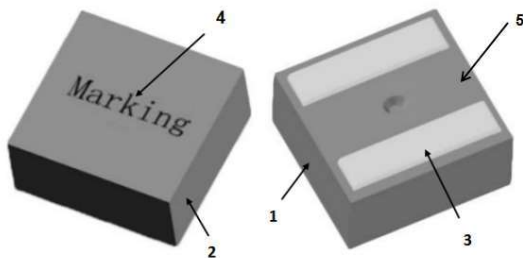

NO	Components	Material
1	CORE	Alloy Powder
2	WIRE	Polyester Wire or equivalent.
3	Clip	100% Pb free solder
4	Ink	Halogen-free ketone
5	paint	Epoxy resin

Recommended Soldering Technologies

(1) Re-flowing Profile

Preheat condition: 150 ~ 200°C/60~120sec.

Allowed time above 217°C: 60~90sec.

Peak temp: 260°C

Max time at Peak temp: 10 sec.

Solder paste: Sn/3.0Ag/0.5Cu

Allowed Reflow time: 2x max

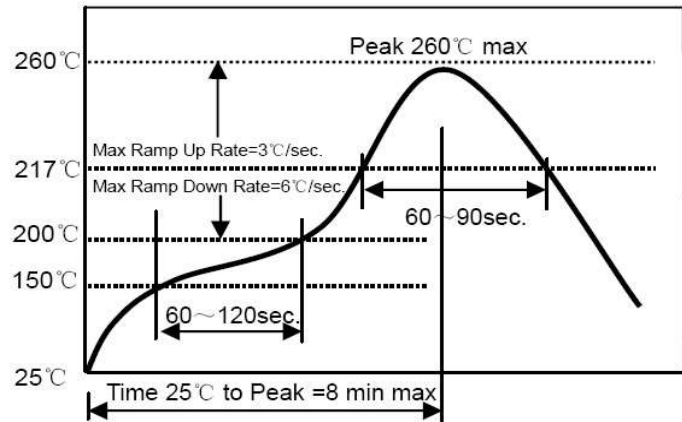

(2) Iron Soldering Profile

Iron soldering power: Max. 30W

Pre-heating: 150°C/60sec.

Soldering Tip temperature: 350°C Max.

Soldering time: 3sec. Max.

Solder paste: Sn/3.0Ag/0.5Cu

Max.1 times for iron soldering

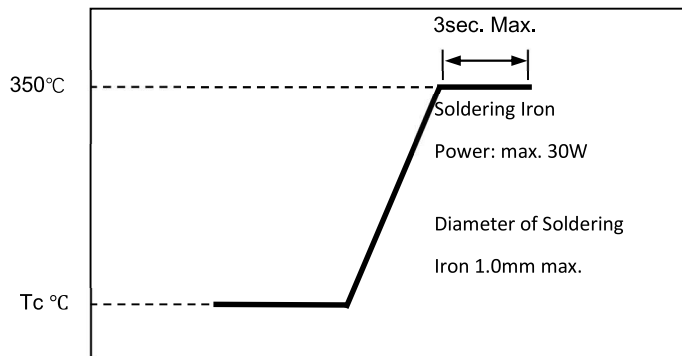

Packaging Information

(1) Tape Packaging Dimensions (Unit: mm)

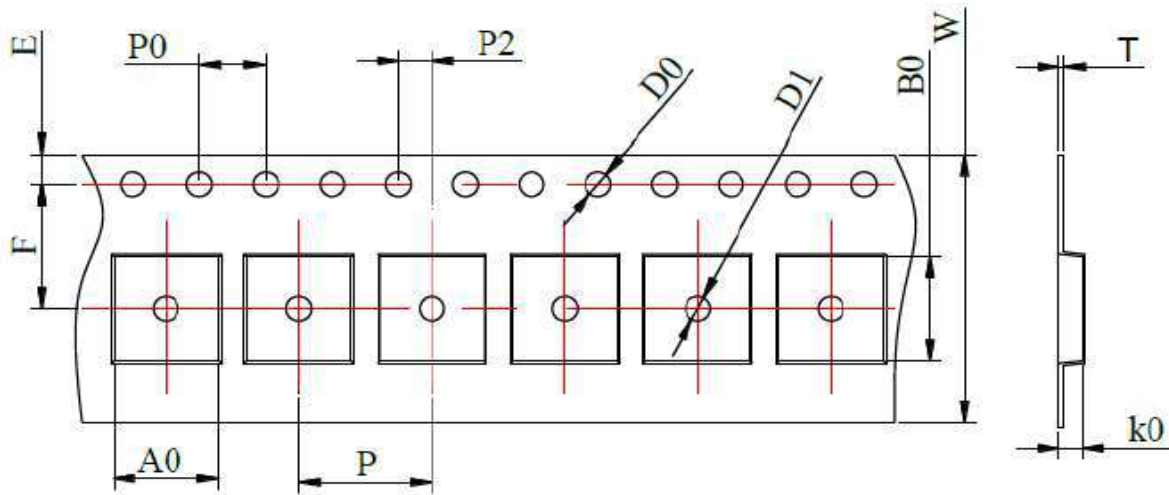

Tape dimensions (mm)											
W	P	P0	P2	D0	D1	T	A0	B0	K0	E	F
16	12	4	2	1.5	1.5	0.35	7.0	6.8	6.3	1.75	7.5
±0.3	±0.1	±0.1	±0.1	±0.1	±0.1	±0.05	±0.1	±0.1	±0.1	±0.1	±0.1

Taping Drawings (UNIT:mm)

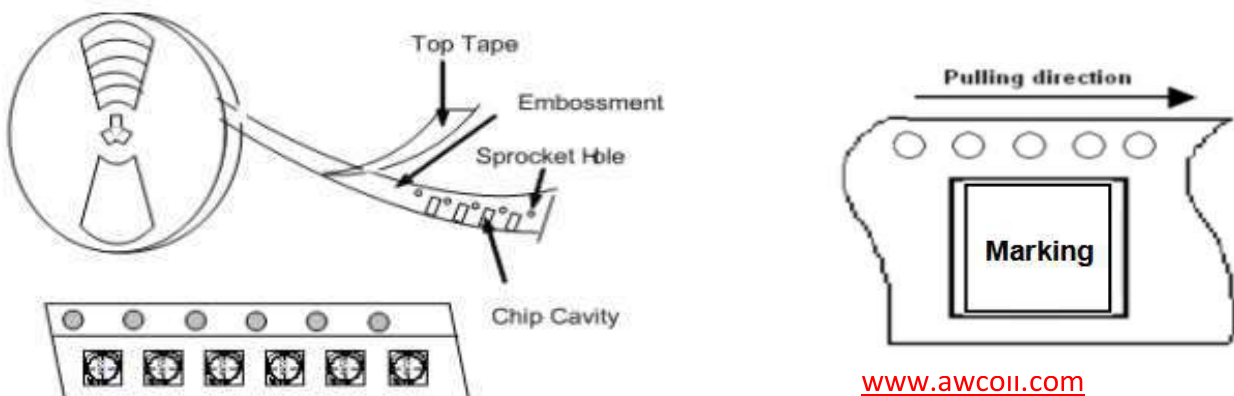

(2) Reel Dimensions (Unit: mm)

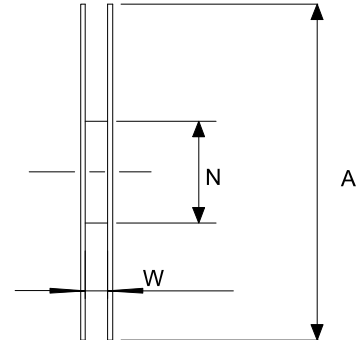
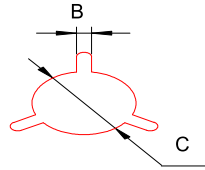
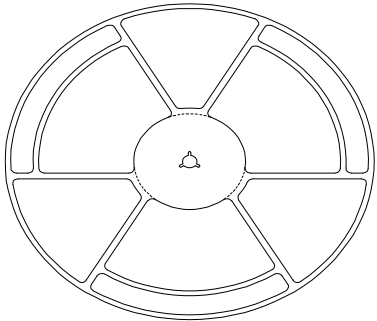

A	W	N	B	C
330±2.0	16.8±0.2	97±0.5	2.2±0.5	13.2±0.2

(3) Packaging Quantity

Standard Quantity		
Reel	Inner box	Carton box
750 pcs / reel	3Reel / box (2250 pcs)	4 Middle boxes, (9,000 pcs)

(4) Peel force of top cover tape

The peel speed shall be about 300mm/minute

The peel force of top cover tape shall be between 0.1 to 1.3 N

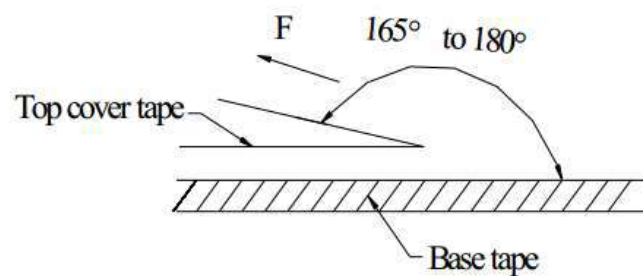

(5) Reel Label

Label on the reel

- Customer's part Number
- Lot Number
- Quantity
- date code

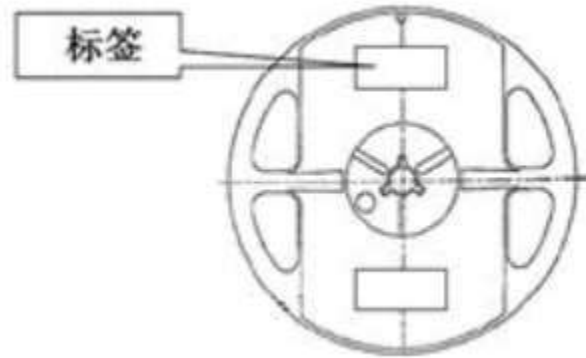

Shipping Label

- Customer's part Number
- Manufacturer's part Number
- Quantity
- Date code

(6) Inner Box

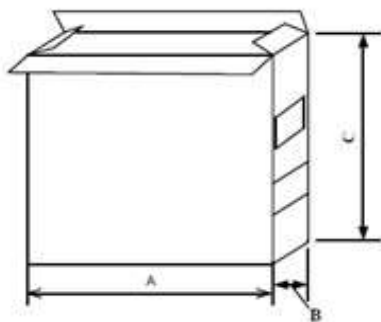

Packaging type	A (mm)	B (mm)	C (mm)
Inner box	335	70	340

(7) Carton

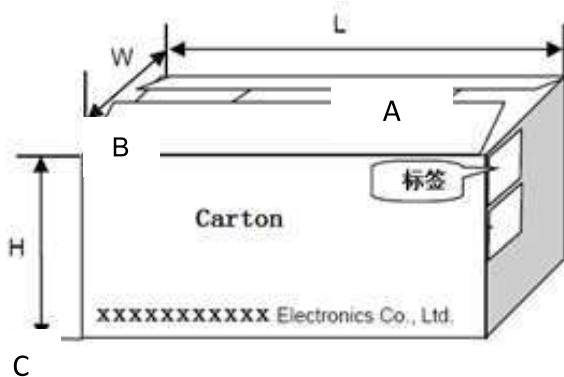

Packaging type	A	B	C
type	360	360	360