

Roller Box

Product Specification Sheet

Description

This roller box has been designed to support and guide flexible lines such as risers, umbilical, flowlines or subsea cables as they are moved across the deck or guided over the side of a vessel or platform. Enables smooth movement, protection and even load distribution to avoid excessive stresses.

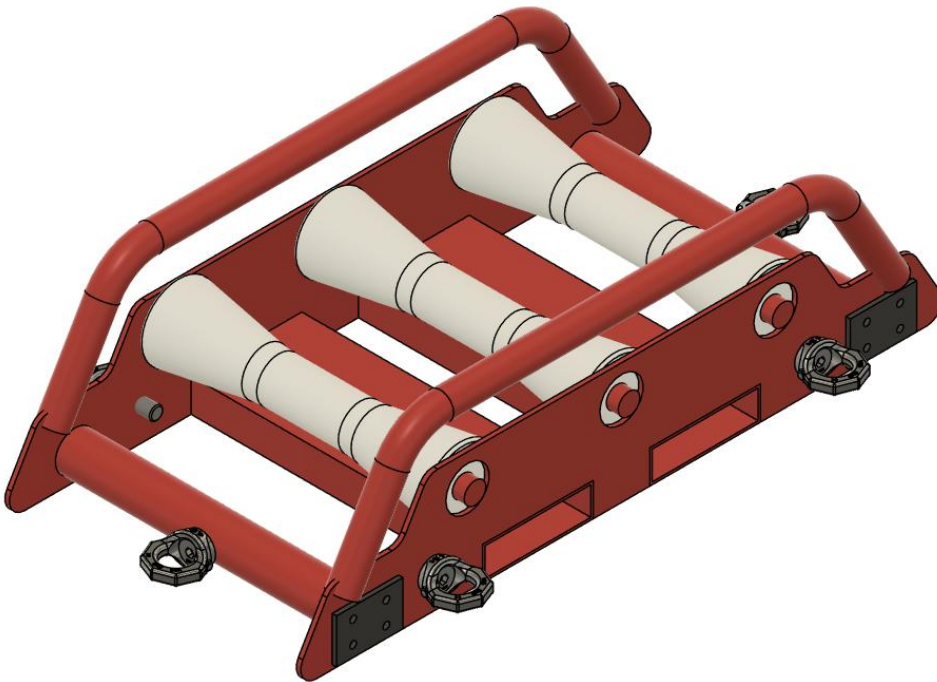

Key Specifications

External Dimensions

(L X W X H) - 1464 X 893 X 418 mm

Pipe Supported Area

(L X W X H) – 795 X 595 X 167 mm

Weight

171 kg

Weight Capacity

450 kg/m

Dimension Capacity

(Min OD, Max OD) – 2”, 14”

Additional Points

- Main Structure - S355 Type Steel
- Rollers – POM Thermoplastic
- Painted Red (RAL 3020)

Drawings

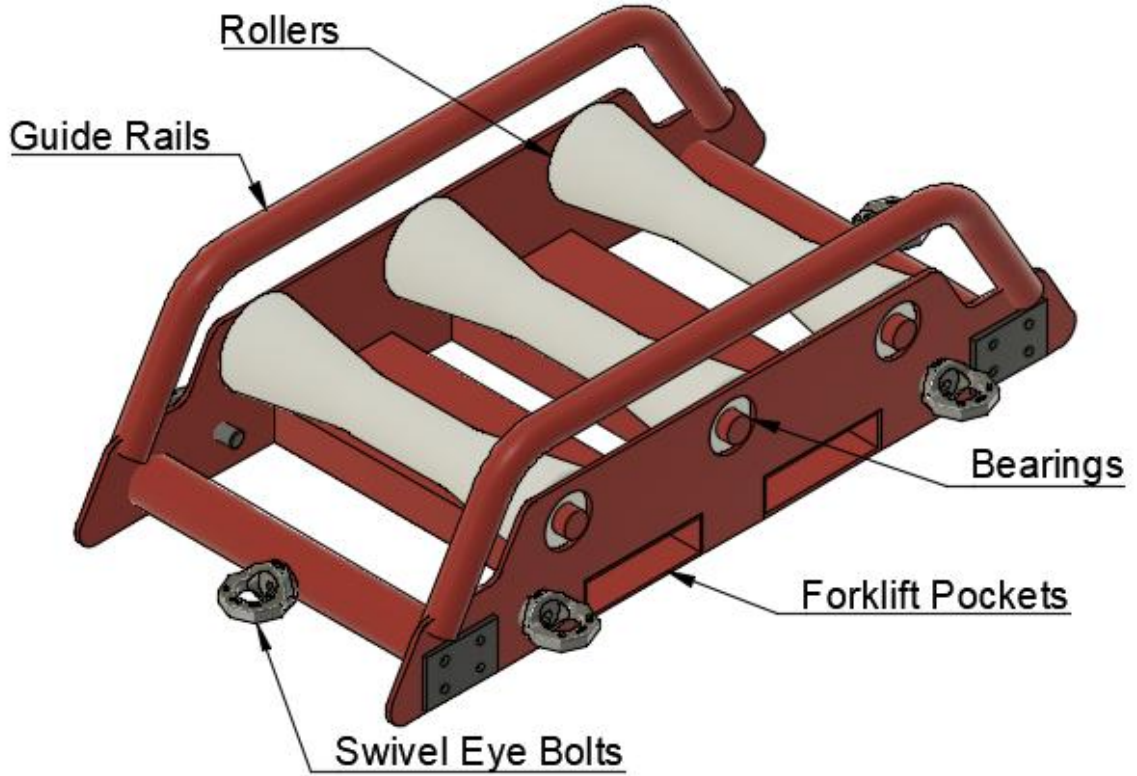

Top View

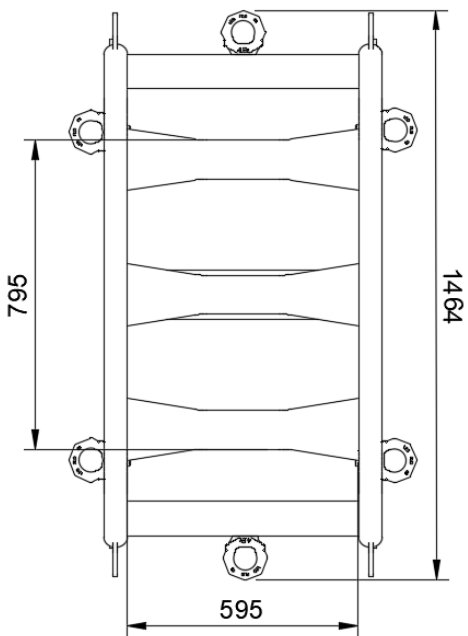

Front View

