

20' Subsea Basket

Product Specification Sheet

Key Specifications

Description

A subsea basket, designed for the efficient delivery of tooling and equipment for subsea operations. Supplied with twistlocks for deck seafastening and detachable, ROV operable handrails.

Internal Dimensions

(L X W X H) - 5700 X 2088 X 1020 mm

External Dimensions with handrails

(L X W X H) - 6322 X 2722 X 1360 mm

External Dimensions without handrails

(L X W X H) - 6000 X 2400 X 1360 mm

Payload

20 Te

Tare

3.5 Te

Rating

23.5 Te

Additional Points

- Operational Class R60
- DNV 2.7-3 Approved
- Main Structure - S355 Type Steel
- Floor Grating - Galvanised Heavy Duty
- Side Grating - GRP
- Painted Yellow (RAL 1004) Norsok M-501, System 1

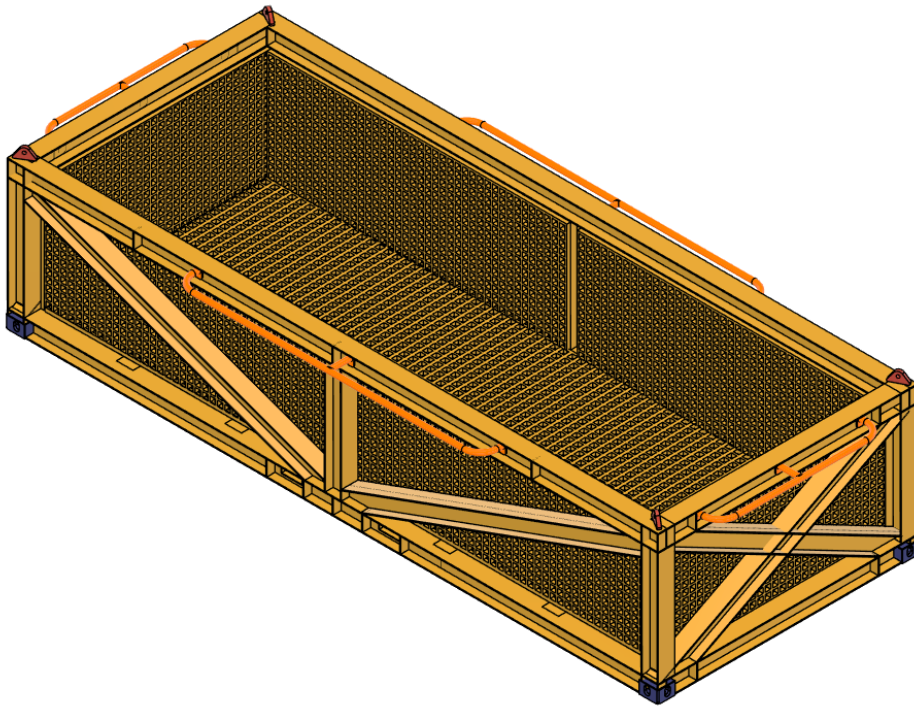

Drawings

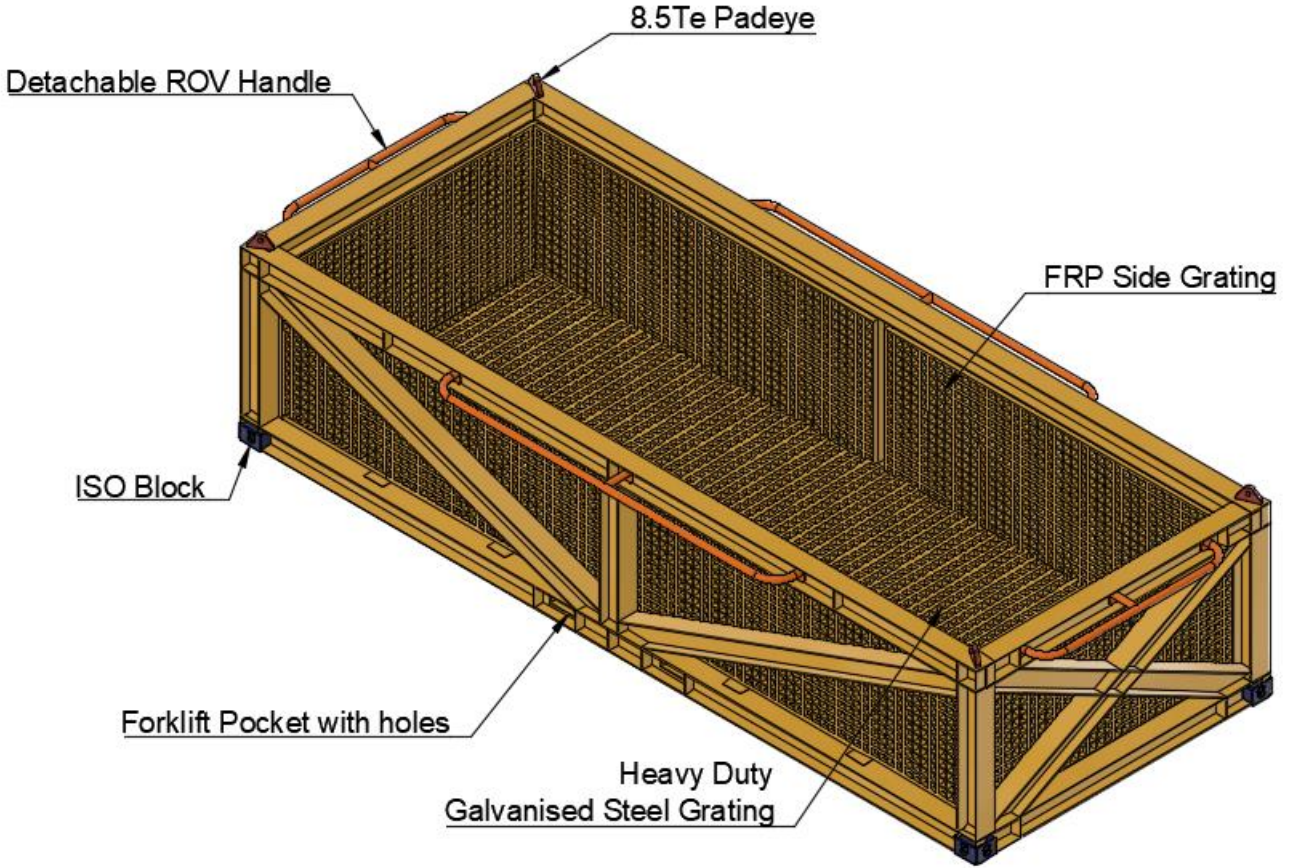

Top View

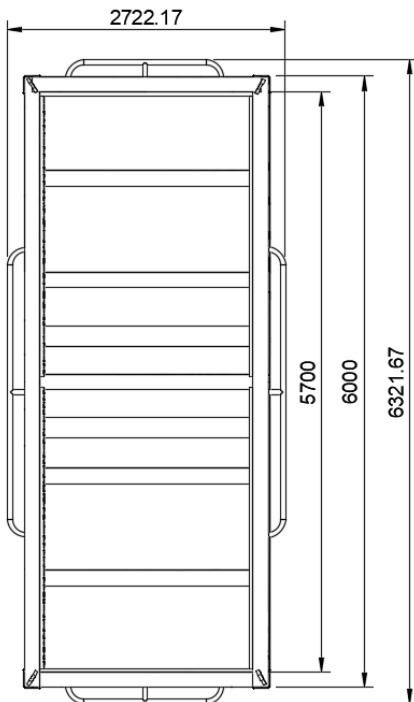

Front View

