

CLP SERIES (Low Profile Locknut)

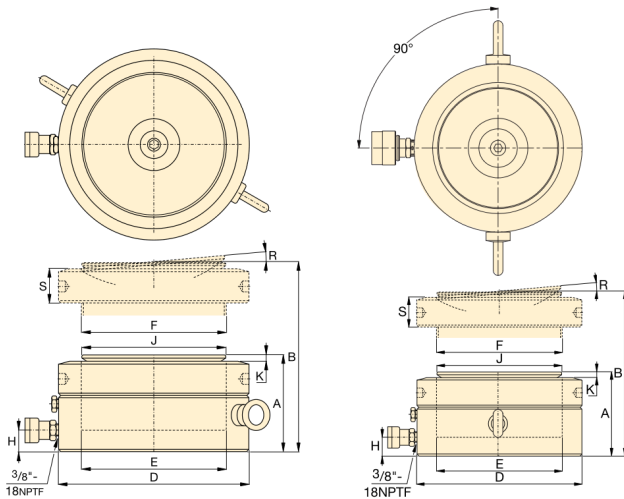

| Model | Capacity tons (kN) | Stroke | | Effective Area | | Oil Capacity | | A Collapsed Height | | B Ext. Height | | D Outside Dia. | | E Cylinder Bore Dia. | |
|----------|-----------------------|--------|------|-----------------|-------------------|-----------------|-------------------|-----------------------|------|------------------|------|-------------------|-------|----------------------------|-------|
| | | mm | inch | cm ² | inch ² | cm ³ | inch ³ | mm | inch | mm | inch | mm | inch | mm | inch |
| CLP-602 | 60 (606) | 50 | 1.97 | 87 | 13.5 | 432 | 26.4 | 125 | 4.92 | 175 | 6.89 | 140 | 5.51 | 105 | 4.13 |
| CLP-1002 | 100 (1027) | 50 | 1.97 | 147 | 22.8 | 734 | 44.8 | 137 | 5.39 | 187 | 7.36 | 175 | 6.89 | 137 | 5.39 |
| CLP-1602 | 160 (1619) | 45 | 1.77 | 231 | 35.8 | 1040 | 63.5 | 148 | 5.83 | 193 | 7.60 | 220 | 8.66 | 172 | 6.77 |
| CLP-2002 | 200 (1999) | 45 | 1.77 | 285 | 44.2 | 1285 | 78.4 | 155 | 6.10 | 200 | 7.87 | 245 | 9.65 | 191 | 7.52 |
| CLP-2502 | 250 (2567) | 45 | 1.77 | 366 | 56.7 | 1650 | 100.7 | 160 | 6.30 | 205 | 8.07 | 270 | 10.63 | 216 | 8.50 |
| CLP-4002 | 400 (3916) | 45 | 1.77 | 559 | 86.6 | 2517 | 153.6 | 178 | 7.01 | 223 | 8.78 | 350 | 13.78 | 267 | 10.51 |
| CLP-5002 | 520 (5114) | 45 | 1.77 | 730 | 113.2 | 3287 | 200.6 | 192 | 7.60 | 237 | 9.33 | 400 | 15.75 | 305 | 12.01 |

| Model | F Plunger Dia. | H Base to Advance Port | | J Saddle Dia. | | K Saddle Protrusion from Plunger | | R Saddle Max. Tilt Angle | S Lock Nut Height | | Weight | |
|----------|-------------------|------------------------------|------|------------------|-------|--|------|--------------------------------|----------------------|------|--------|-------|
| | mm | mm | inch | mm | inch | mm | inch | | mm | inch | kg | lbs |
| CLP-602 | Tr104X4 | 19 | 0.75 | 96 | 3.78 | 6 | .24 | 5° | 28 | 1.10 | 15 | 33.1 |
| CLP-1002 | Tr136X6 | 21 | 0.83 | 126 | 4.96 | 8 | 0.31 | 5° | 31 | 1.22 | 26 | 57.3 |
| CLP-1602 | Tr171X6 | 27 | 1.06 | 160 | 6.30 | 9 | 0.35 | 5° | 40 | 1.57 | 44 | 97.0 |
| CLP-2002 | Tr190X6 | 30 | 1.18 | 180 | 7.09 | 10 | 0.39 | 5° | 43 | 1.69 | 57 | 125.7 |
| CLP-2502 | Tr216X6 | 32 | 1.26 | 200 | 7.87 | 11 | 0.43 | 5° | 44 | 1.73 | 74 | 163.1 |
| CLP-4002 | Tr266X6 | 39 | 1.54 | 250 | 9.84 | 11 | 0.43 | 4° | 55 | 2.17 | 134 | 295.4 |
| CLP-5002 | Tr305X6 | 48 | 1.89 | 290 | 11.42 | 10 | 0.39 | 3° | 62 | 2.44 | 189 | 416.7 |