



# EW76501

## Coolant Exchange Machine



## Operations Manual

# TABLE OF CONTENTS

<b>INTRODUCTION TO THE MACHINE .....</b>	<b>2</b>
<b>CUSTOMER SERVICE CONTACT INFO .....</b>	<b>2</b>
<b>SAFETY INFORMATION .....</b>	<b>3</b>
<b>MACHINE SPECIFICATIONS &amp; FEATURES .....</b>	<b>9</b>
<b>MACHINE OVERVIEW .....</b>	<b>10</b>
<b>OPERATING INSTRUCTIONS .....</b>	<b>11</b>
<b>MAINTENANCE .....</b>	<b>15</b>
<b>REPLACEMENT PARTS .....</b>	<b>16</b>
<b>WARRANTY INFORMATION .....</b>	<b>18</b>

# **INTRODUCTION** *to the* **Wynn's Coolant Machine**

Congratulations on the purchase of your Wynn's Coolant Machine!

This is a device that removes and refills engine coolant and also pressure tests the cooling system. Coolant is extracted and refilled through the upper radiator hose connection without the vehicle's engine running.

Simply put, this machine is the cleanest, safest and most thorough method of radiator fluid exchange ever devised. Suddenly, cooling system maintenance has become a more realistic proposition. Fluid exchanges are cleaner and neater than ever!

Service neglect causes engine coolant to break down which can lead to the engine freezing or overheating. Historically, cooling system fluid service has been neglected, often due to the lack of a convenient method for providing such flush or fluid exchange services. Previous methods for exchanging the cooling system or replacing the coolant were time consuming and often inefficient or incomplete. Now, it's easier than ever to replace virtually **all** of the old coolant in less than 8 minutes, to ensure your car's cooling system has a long, trouble-free life.

**Please take time to read through this manual to familiarize yourself with the machine before performing your first coolant exchange.**

## **CUSTOMER SERVICE CONTACT INFORMATION**

For product information, tech support, or to order replacement parts,  
please call: **833-303-4644**  
or visit: ***equipment.wynnsusa.com***

# IMPORTANT SAFETY NOTICE

For your safety, read this manual thoroughly before operating this machine. This machine is intended for use by properly trained, skilled professional automotive technicians. The safety messages presented below and throughout this user's manual are reminders to the operator to exercise care when using this unit. Before using this machine, always refer to and follow the safety messages and applicable service procedures provided by the manufacturer of the vehicle being serviced.

## • Read All Safety Instructions

Read, understand and follow all safety messages and instructions in this manual. Safety messages in this section of the manual contain a signal word with a three-part message and, in some instances, an icon.

## • Signal Words

The signal word indicates the level of the hazard in a situation:

### **DANGER**

*Indicates an imminently hazardous situation which, if not avoided, will result in death or serious injury to the operator or to bystanders.*

### **WARNING**

*Indicates a potentially hazardous situation which, if not avoided, could result in death or serious injury to the operator or to bystanders.*

### **CAUTION**

*Indicates a potentially hazardous situation which, if not avoided, may result in moderate or minor injury to the operator or to bystanders.*

### **IMPORTANT**

*Indicates a situation which, if not avoided, may result in damage to the machine, or the vehicle being serviced.*

## • Safety Messages

Safety messages in this section contain three different type styles:

- Normal type states the hazard.
- **Bold type** states how to avoid the hazard.
- *Italic type* states the possible consequences of not avoiding the hazard.

## • Safety Symbols

A safety symbol, when present, gives a graphical description of the potential hazard, and how to avoid the hazard:



**Risk of Fire**



**Read Instructions Before Use**



**Risk of Explosion**



**Mandatory Eye Protection**



**Risk of Entanglement**



**Mandatory Protective Gloves**



**Dangerous Fumes**



**Mandatory Protective Clothing**



**Do Not Pull or Move**



**Risk of Burns**

# IMPORTANT SAFETY INSTRUCTIONS

## DANGER



Engine exhaust contains toxic gases.

- **Vent vehicle's exhaust away from work area.**
- **Do not breathe exhaust.**

*Exhaust gases will cause injury or death.*

## WARNING



Improper use and operation.

- **Read, understand and follow all safety messages and operational procedures in this manual before operating this machine.**
- **This equipment should be operated only by qualified personnel.**
- **Use this equipment only as described in this manual.**

*Improper use and operation of this product can result in injury.*

## WARNING



Engine systems can malfunction expelling fuel, oil vapors, hot steam, hot toxic exhaust gases and other flying particles.

- **Wear safety goggles and protective clothing, user and bystander. Everyday eyeglasses only have impact resistant lenses; they are NOT safety glasses.**
- **Do not position head directly over or in front of carburetor or throttle body. Engine backfire can occur when air cleaner is out of normal position.**
- **Make sure gauge reads zero before connecting or disconnecting hose connections to adapters.**
- **Make sure cooling system pressure has been relieved before connecting or disconnecting hose connections and adapters.**
- **Keep a dry chemical (Class B) fire extinguisher rated for gasoline, chemical & electric fires in the work area.**

*Fire, explosion, or flying particles may cause serious injury.*

## WARNING

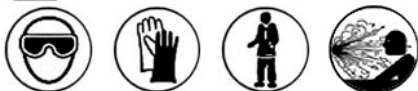

Risk of expelling pressurized fluids.

- **Wear safety goggles and protective clothing, user and bystander.**

- Engine systems can malfunction, expelling fuel, oil vapors, hot steam, hot toxic exhaust gases and other debris.
- Always unplug the machine from its power source when not in use.
- Keep the service hoses away from hot or moving engine parts. Hoses can split or burst causing fluid to be expelled.
- Avoid contact with engine coolant.
- Treatment methods are as follows:
  - Eyes: Flush eyes with plenty of water.
  - Skin: Wash with soap and water.
  - Inhalation: Move to uncontaminated area.
  - Ingestion: If large amount, get medical attention.
  - If any irritation persists, get medical attention.
- Dispose of used fluid according to environmental laws and regulations.

*Fuel, oil vapors, hot steam, hot toxic exhaust gases, pressurized fluid, and other debris can cause serious injury.*

## **WARNING**

Risk of unexpected vehicle movement.

- Block drive wheels before starting vehicle's engine to begin an exchange.
- Unless instructed otherwise, set parking brake and put gear selector in park.
- Do not leave a running vehicle unattended.
- If vehicle has an automatic parking brake release, disconnect release mechanism for testing and reconnect when testing is completed.

*A moving vehicle can cause injury.*

## **WARNING**



Risk of entanglement. Engine has moving parts.

- Do not place tools on fenders or other places in engine compartment.
- Keep yourself, clothing, battery cables and service hoses clear of moving parts such as fan blades, belts, pulleys, hood and doors.
- Barriers are recommended to help identify danger zones in test area.
- Prevent personnel from walking through immediate test area.

*Contact with moving parts can cause injury.*

## **WARNING**



Risk of fire or explosion.

- Do not operate in the vicinity of open containers of flammable liquids such as gasoline.
- Keep hoses and jumper cables away from heat sources and sharp edges.
- Do not operate equipment with damaged cords or hoses until they have been examined by a qualified serviceman.

*Fire or explosion can cause injury.*

## **WARNING**



Risk of fire or explosion. Gases produced by a battery are highly explosive.

- **Wear safety goggles and protective clothing, user and bystander.**
  - **Do not smoke, place metal tools on battery or allow a spark or flame in vicinity of battery.**
- Battery explosion can cause injury.*

## **WARNING**



Risk of burns.

- **Wear gloves when handling hot engine components.**
  - **Do not remove radiator cap unless engine is cold.**
  - **Pressurized engine coolant may be hot.**
  - **Do not touch hot exhaust systems, manifolds, engines, radiators, etc.**
- Hot fluid and engine parts may cause injury.*

## **WARNING**



Battery acid is a highly corrosive sulfuric acid.

- **Wear safety goggles and protective gloves, user and bystander.**
  - **Have plenty of fresh water and soap nearby. If battery acid contacts skin, clothing, or eyes, flush exposed area with soap and water for 10 minutes.**
  - **Do not touch eyes while working near battery.**
- Battery acid can burn eyes and skin.*

## **WARNING**



Risk of burns.

- **Wear gloves when working near hot engine components.**
  - **Do not touch hot exhaust systems, manifolds, engines, radiators, etc.**
  - **The fluid coming from the vehicle along with some of the machine's components that the fluid comes into direct contact with (i.e. hoses and fittings) may reach temperatures uncomfortable to the touch. Exercise caution in avoiding contact with these items.**
- Hot components can cause injury or discomfort.*



## CAUTION



Risk of injury.

- This equipment should be operated by qualified personnel only.
- Use this equipment only as described in this manual.
- Always disconnect the machine from air source when not in use.
- Loop the pressure hose loosely in its proper location when machine is not in use.
- Do not operate equipment with a damaged hose, or if the equipment has been dropped or damaged, until it has been examined by a qualified service representative.
- Care should be taken to arrange the service hoses so that they will not be tripped over or pulled.
- Never pull on the service hoses to transport the machine. Damage may occur to these components, or machine may tip over.
- Keep area of operation clear of unnecessary tools and equipment. Utilize recessed tool storage areas on the top of the machine.
- Never leave the machine running unattended.
- This machine is not designed for any other purpose than the servicing of automotive cooling systems.

*Operation of this machine by anyone other than qualified personnel may result in injury.*

## CAUTION

Misdiagnosis may lead to incorrect or improper repair and/or adjustment.

- Do not rely on erratic, questionable, or obviously erroneous test information or results. If test information or results are erratic, questionable, or obviously erroneous, make sure that all connections and data entry information are correct and that the test procedure was performed correctly. If test information or results are still suspicious, do not use them for diagnosis.

*Improper repair and/or adjustment may cause vehicle or equipment damage or unsafe operation.*

## IMPORTANT

Risk of equipment damage.

- Servicing, transporting, or storing this machine in an attitude other than the normal operating position can result in fluid spillage and/or component damage.
- Never pull on the service hoses to transport the unit. Damage may occur to these components, or machine may tip over. Always use the handle to move.
- Periodically clean the machine by wiping down with a clean, soft, dry cloth.

*Improper operation of equipment may result in damage to machine or components.*

**SAVE AND FOLLOW THESE INSTRUCTIONS!**

# MACHINE SPECIFICATIONS

**Dimensions:** 43" H x 24" W x 28" D

**Weight:** 95 lbs.

**New Fluid Tanks:** 24 Qt.

**Waste Fluid Tank:** 24 Qt.

**Power:** 12V DC Power

## FEATURES

The Wynn's Coolant Exchange Machine helps extend the life of the cooling system components by keeping it clean and functioning as efficiently as possible. When used with corresponding Wynn's products, the Coolant Exchange Machine helps facilitate dissolving harmful deposits, suspending them in old coolant for easy removal.

- ✓ Reverse Flow Operation for Complete Service with Engine Off
- ✓ Disconnection is Performed with Coolant at Ambient Temperature
- ✓ Coolant System Pressure Relief Feature for Safe Access to Hot Cooling System
- ✓ Built-In Loop Mode
- ✓ Automatic Shut-Off Upon Service Completion
- ✓ EVAC Feature for Easy Fluid Removal in Overflow Tank
- ✓ Quick-Connect Adapter System
- ✓ Convenient, Portable Roll-Around Unit

# MACHINE OVERVIEW

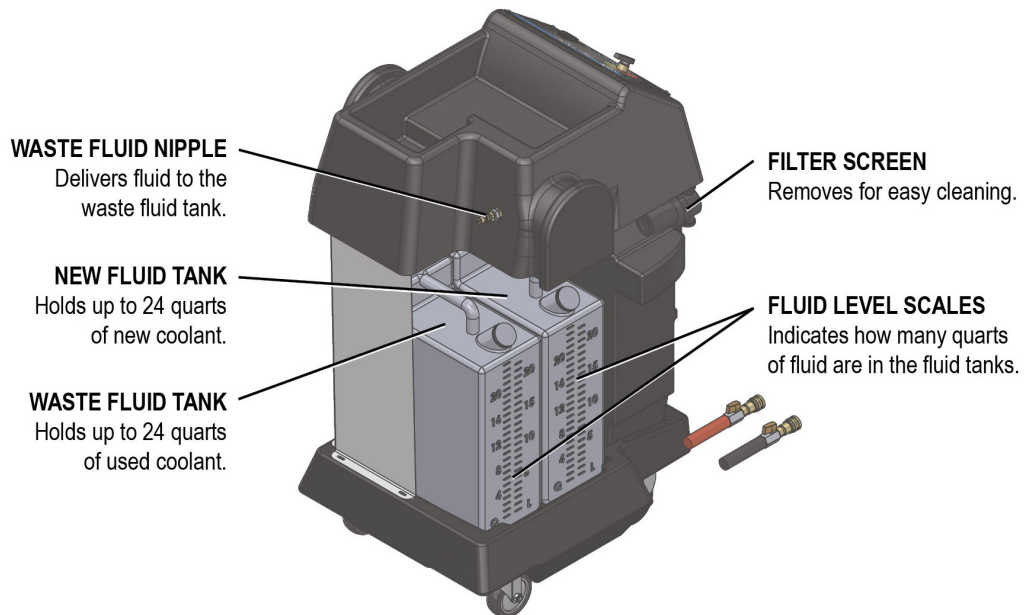
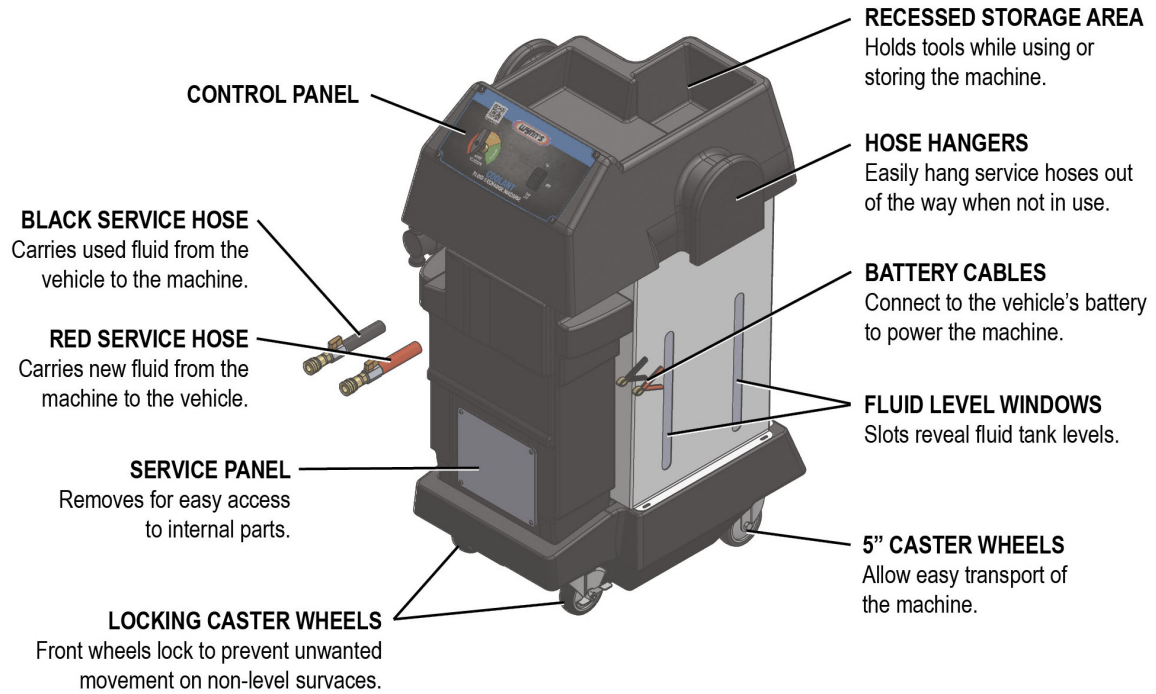

# OPERATING INSTRUCTIONS

**IMPORTANT:** Machine needs 12V DC power to operate.

## SAFETY RECOMMENDATIONS

Use extreme caution when working around a running engine.

Always block the vehicle's drive wheels.

Ventilate the vehicle's exhaust.

Always wear safety glasses.

It's a good idea to wear insulated gloves.



## PREPARATION

Road test the vehicle at least one mile.

Make sure there are no problems with the Engine Cooling System such as leaks, low fluid level and soft or damaged hoses.

Connect battery cables to vehicle's battery.

## DEPRESSURIZE THE COOLING SYSTEM

Connect machine's battery cables to vehicle's battery. The green light on the machine will illuminate.





Attach the machine's **RED** service hose to the waste fluid nipple on the back of the machine, and open the ball valve.

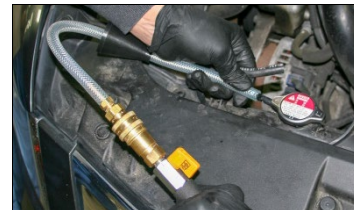

Attach the machine's **BLACK** vacuum hose with open end adapter to the vehicle's overflow nipple at the radiator cap and open ball valve.

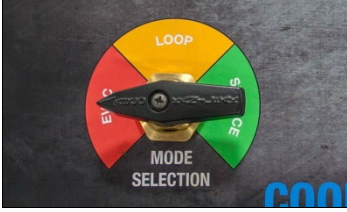

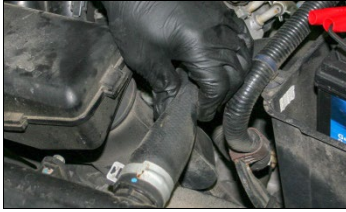
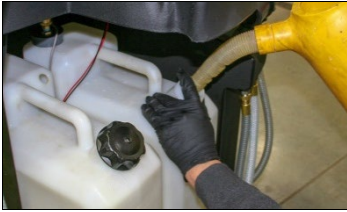

<p>Turn the MODE SELECTION dial to <b>EVAC</b>.</p> <p>Press and hold switch in the <b>TOP OFF</b> position.</p> <p>At this time, vacuum should be applied to the overflow nipple.</p>	 
<p>For 2-stage pressure caps, carefully turn the cap <math>\frac{1}{4}</math> to <math>\frac{1}{2}</math> turn to relieve the pressure. <b>Only loosen to the first stage. DO NOT turn far enough to remove the cap.</b> The vacuum that is being applied to the nipple will relieve the pressure safely into the machine.</p> <p>When the system has been depressurized, you should be able to easily pinch the radiator hose closed between your thumb and finger.</p>	 
<p>Look up the type and quantity of coolant for the vehicle in a coolant specification guide, electronic data base or other source.</p> <p>Fill the machine's new fluid tank with the appropriate solution of antifreeze (coolant)/water.</p> <p>Always use the machine's measuring scale for quantity. The tank holds extra coolant for top off reasons, so you may need to replenish.</p>	

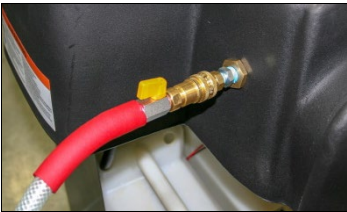
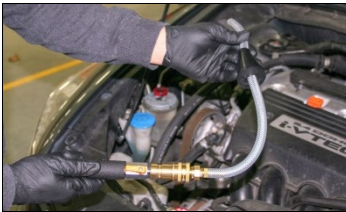
**EVAC OLD COOLANT**

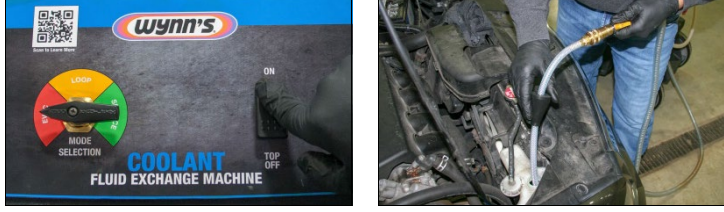
<p>Attach the machine's <b>RED</b> service hose to the waste fluid nipple on the back of the machine and open ball valve.</p> <p>Attach the open-ended adapter to the machine's <b>BLACK</b> vacuum hose and open ball valve.</p>	 
---	---

<p>Use the <b>BLACK</b> vacuum hose to suction out the overflow reservoir and reduce the radiator level to reduce spillage when you disconnect the radiator hose. To do this, Turn the MODE SELECTION dial to <b>EVAC</b>, set the switch to the <b>ON</b> position, and suction where needed.</p> <p><b>NOTE:</b> The service hose must be connected, or the suction tool won't work. When suctioning the overflow reservoir, do not try to pull out solids that may have accumulated in the bottom. To clean these solids may require reservoir removal and off-car cleaning.</p>	 <p>The image shows the Wynn's Coolant Fluid Exchange Machine on the left, which has a mode selection dial with 'EVAC' highlighted in black. To the right, a person is using the machine's hoses to service a car's cooling system.</p>
---	---

**PERFORM COOLING SYSTEM EXCHANGE**

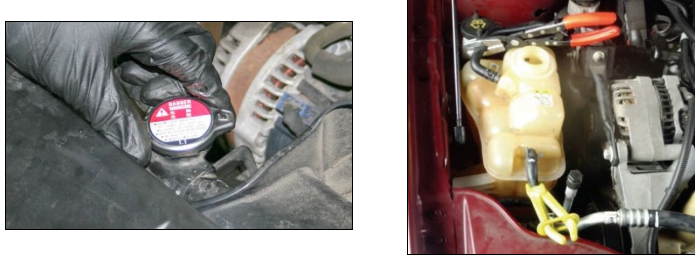
<p><b>IMPORTANT:</b> For the following steps, always use worm gear style clamps to secure the adapters. Never use pinch type clamps for this process!</p>	 <p>Two worm gear style clamps are shown, used for securing adapters to hoses.</p>
<p>Attach the adapters to the open end of the hose and either the radiator neck or vehicle goose neck, whichever is available.</p> <p>Attach the <b>RED</b> service hose to the adapter toward the thermostat and open ball valve.</p> <p>Attach the <b>BLACK</b> vacuum hose to the other adapter toward the radiator and open ball valve.</p>	 <p>Two images show the process of attaching the red and black hoses to the engine's cooling system components.</p>
<p>Pour the entire contents of a Wynn's "Cooling System Cleaner" into the radiator. Top off the cooling system with water and secure the radiator cap.</p> <p>With pinch pliers, block the overflow and remote reservoir hoses.</p>	 <p>Two images show the final steps: pouring cleaner into the radiator and blocking the overflow and remote reservoir hoses with yellow pinch pliers.</p>

<p>Turn the MODE SELECTION dial to <b>LOOP</b>.</p> <p>Set the heat to high and the blower to the lowest setting. Start the engine and set idle at 1200 to 1500 rpm (use “Throttle Depressor Tool” or other means) and allow the engine to reach operating temperature. You will know when this occurs by observing coolant through the hoses. Allow the engine to run an additional 10 minutes to allow the cleaner to do its job.</p> <p><b>NOTE:</b> After the cleaner has time to neutralize acids and remove rust and scale, remove the “Throttle Depressor Tool” or return to idle speed as applicable and turn the engine off.</p>	
<p>Turn the MODE SELECTION dial to <b>SERVICE</b> and set the switch to the <b>ON</b> position.</p> <p>During the service, the thermostat will be held open by pressure from the machines pump, which will allow new coolant to be pushed into the cooling system while used coolant is pushed to the machine’s waste tank.</p> <p>When the service is complete, the pump will stop, the red light on the switch will illuminate, and an audible tone will sound.</p> <p><b>NOTE:</b> It is normal for some fluid to be left over in the machine’s new fluid tank.</p>	
<p>Set the switch to the <b>OFF</b> position.</p> <p>Close the ball valves on the <b>RED</b> and <b>BLACK</b> service hoses.</p> <p>Carefully disconnect the machine’s adapters from the vehicle and reconnect the vehicle’s hoses.</p>	

Return Vehicle to Normal Operation	
------------------------------------	--

<b>RETURN VEHICLE TO NORMAL OPERATION</b>	
<p>Carefully proceed with disconnecting the machine and adapters, reconnect the radiator hose.</p> <p>Add any additional products at this time.</p> <p>Top off radiator and fill the overflow reservoir to the appropriate level.</p> <p>Perform system air bleeding as necessary.</p> <p>Allow vehicle to run; check for leaks and check for overheating.</p>	

<b>DRAIN THE USED FLUID TANK</b>	
<p>Remove the tank from the machine by grasping the handle on top of the tank.</p> <p>Remove the drain hose from the tank.</p> <p>Remove the cap and pour the contents into an approved disposal container.</p> <p>Replace the cap and drain hose, and place the tank back into the machine.</p>	

## MAINTENANCE

### To keep your machine working properly...

- Keep debris out of new fluid tanks.
- Ensure filter screen is clean before each use.
- Avoid spilling fluid on the control panel.



# REPLACEMENT PARTS

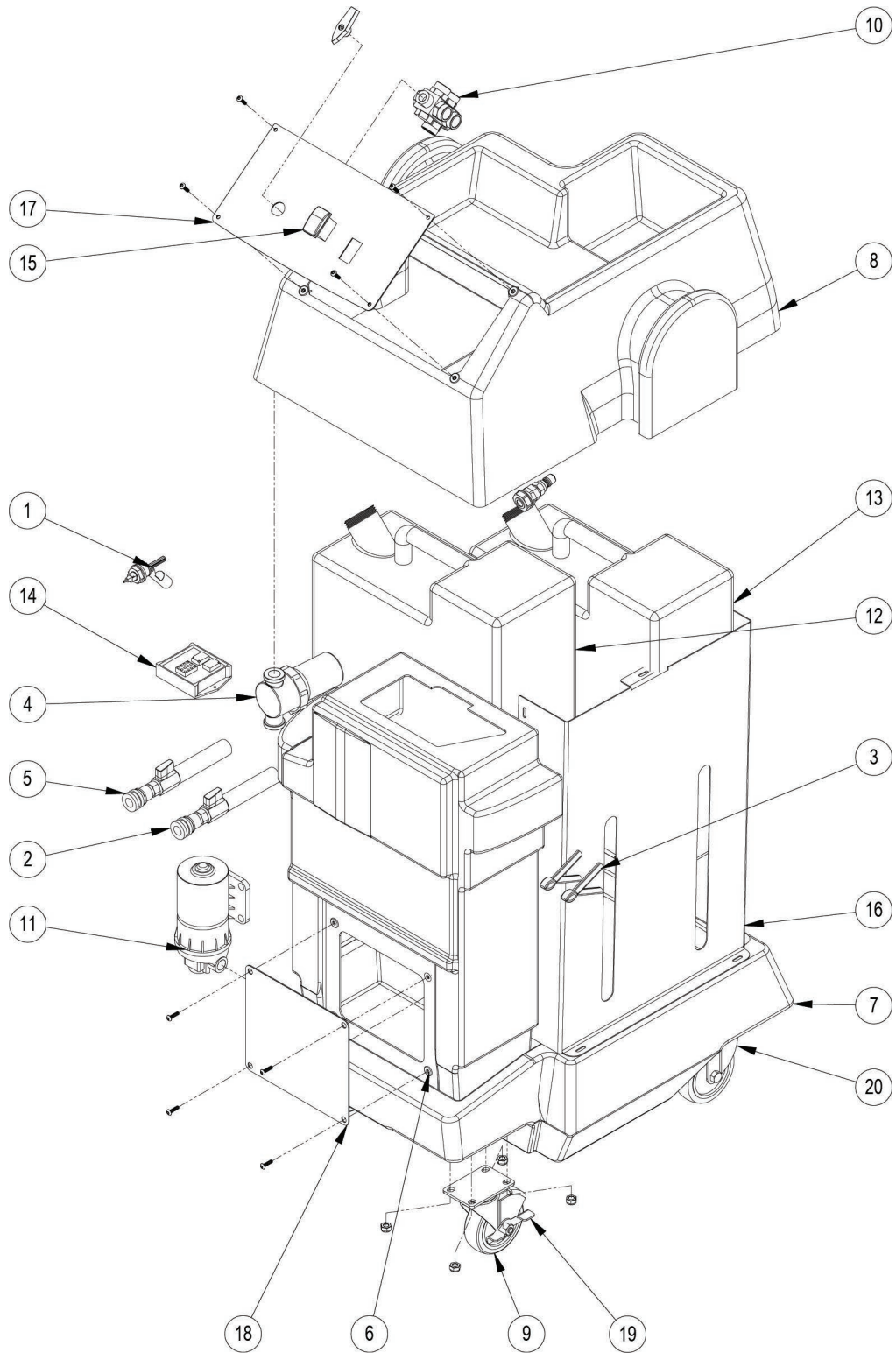

ITEM NO.	PART NO.	DESCRIPTION	QTY.
1	R941251	LS-7 POLY LEVEL SWITCH	1
2	941346	RED SERVICE HOSE	1
3	941396W	BATTERY CABLE ASSEMBLY	1
4	941463	T - STRAINER 50X50 MESH 1/2 NPT	1
5	941467	BLACK SERVICE HOSE	1
6	941602	CONSOLE - BLACK	1
7	941603	CHASSIS - BLACK	1
8	941604	TOP - BLACK	1
9	942137W	WHEEL ONLY 4" CASTERS	4
10	40200547	STACKED BRASS BALL VALVE	1
11	40200557	COOLANT PUMP	1
12	40200617	USED FLUID TANK 6 GAL	1
13	40200618	NEW FLUID TANK 6 GAL	1
14	40200729	CONTROL BOX ONLY - W/COOLANT EXCH MACHINE	1
15	40200730	SWITCH ONLY - W/COOLANT EXCH MACHINE	1
16	40300289	BOTTOM SUPPORT PANEL	1
17	40300303	PANEL- OVERLAY ASSEMBLY	1
18	40300310	SERVICE PANEL- OVERLAY ASSEMBLY	1
19	R942118	CASTER 4" W/BRAKE	2
20	R942137	CASTER 4" SWIVEL	2

# Wynn's Equipment Limited Warranty Terms and Conditions

(1 Year on Equipment / 2 Years on Parts)

Seller warrants to its distributors that under normal use, care and service, the Equipment (except as otherwise provided herein) shall be free from defects in material and workmanship for One (1) year from the date of original invoice (unless a machine was put into inventory and later sold (such sale from inventor to occur no later than [six (6) months] after the date of original invoice), and a distributor can provide proof of sale and registered warranty card, then the one-year warranty will begin on the registration date) for all Equipment with an additional 12 months of coverage for **parts only**. External hoses, remote control modules, adapters and all other attachments, supplies and consumables (except as otherwise provided herein) are warranted for 90 calendar days from the date of original invoice. Filter elements are not warranted. Printed circuit boards purchased from Seller will be warrantable for a period of one (1) years from original purchase date, and any repair services for machines under warranty or to a purchased circuit board by an ITW employee or authorized representative shall be reimbursed.

**SELLER'S OBLIGATIONS UNDER THIS WARRANTY ARE LIMITED SOLELY TO THE REPAIR OR, AT SELLER'S OPTION, REPLACEMENT OF EQUIPMENT OR PARTS, AND LABOR COSTS ASSOCIATED WHICH TO SELLER'S SATISFACTION ARE DETERMINED TO BE DEFECTIVE AND WHICH ARE NECESSARY, IN SELLER'S JUDGEMENT, TO RETURN THE EQUIPMENT TO GOOD OPERATING CONDITION. NO OTHER WARRANTIES EXPRESS OR IMPLIED OR STATUTORY, INCLUDING WITHOUT LIMITATION ANY IMPLIED WARRANTY OF MERCHANTABILITY OR FITNESS FOR A PARTICULAR PURPOSE, SHALL APPLY AND ALL SUCH WARRANTIES ARE HEREBY EXPRESSLY DISCLAIMED.**

This warranty does not cover (and separate charges for parts, labor and related expenses shall apply to) any damage to, malfunctioning, inoperability or improper operation of the Equipment caused by, resulting from or attributable to (A) abuse, misuse or tampering; (B) alteration, modification or adjustment of the Equipment by anyone other than Seller's authorized representatives; (D) improper or negligent use, application, operation, care, cleaning, storage or handling; (E) fire, water, wind, lightning or other natural causes; (F) adverse environmental conditions, including, without limitation, excessive heat, moisture, corrosive elements, or dust or other air contaminants, radio frequency interference, electric power failure, power line voltages beyond those specified for the equipment, unusual physical, electrical or electromagnetic stress, and/or any other condition outside of Seller's environmental specifications; (G) use of the Equipment in combination or connection with other equipment, attachments, supplies or consumables not manufactured or supplied by Seller; or (H) failure to comply with any applicable federal, state or local regulation.

Repairs or replacements qualifying under this Warranty will be performed on regular business days during Seller's normal working hours within a similar timeframe and process as BUYER already has in place, to be accomplished by Wynn's/QMI distributors with the support and cooperation of the SELLER, or by SELLER or SELLER's subcontractors if that is acceptable to the BUYER following Purchaser's request or if agreed to between Seller and Buyer by Purchaser's/ ITW staff if necessary. All requests for Warranty service must be made during the stated Warranty period. **This warranty is non-transferable.**