



EW95501

Brake Fluid Exchange Machine



Operations Manual

TABLE OF CONTENTS

INTRODUCTION TO THE MACHINE	2
CUSTOMER SERVICE CONTACT INFORMATION	2
SAFETY INFORMATION	3
MACHINE SPECIFICATIONS & FEATURES	9
MACHINE OVERVIEW	10
OPERATING INSTRUCTIONS	11
MAINTENANCE	14
REPLACEMENT PARTS	15
WARRANTY INFORMATION	17

INTRODUCTION *to the* **Wynn's Brake Fluid Exchange Machine**

Congratulations on the purchase of your Wynn's Brake Fluid Exchange Machine!

Brake service is now more profitable, since we have eliminated the need for a second technician when performing a brake bleeding service.

This machine provides the shop with the ability to service and pressure test a brake system faster and easier than ever before with a combination of speed and effectiveness.

Please take time to read through this manual to familiarize yourself with the machine before performing your first brake fluid exchange.

CUSTOMER SERVICE CONTACT INFORMATION

For product information, tech support, or to order replacement parts,
please call: **833-303-4644**
or visit: ***equipment.wynnsusa.com***

IMPORTANT SAFETY NOTICE

For your safety, read this manual thoroughly before operating this machine. Your machine is intended for use by properly trained, skilled professional automotive technicians. The safety messages presented below and throughout this user's manual are reminders to the operator to exercise care when using this unit. Before using your machine, always refer to and follow the safety messages and applicable service procedures provided by the manufacturer of the vehicle being serviced.

• Read All Safety Instructions

Read, understand and follow all safety messages and instructions in this manual. Safety messages in this section of the manual contain a signal word with a three-part message and, in some instances, an icon.

• Signal Words

The signal word indicates the level of the hazard in a situation:

DANGER

Indicates an imminently hazardous situation which, if not avoided, will result in death or serious injury to the operator or to bystanders.

WARNING

Indicates a potentially hazardous situation which, if not avoided, could result in death or serious injury to the operator or to bystanders.

CAUTION

Indicates a potentially hazardous situation which, if not avoided, may result in moderate or minor injury to the operator or to bystanders.

IMPORTANT

Indicates a situation which, if not avoided, may result in damage to the machine, or the vehicle being serviced.

• Safety Messages

Safety messages in this section contain three different type styles:

- Normal type states the hazard.
- **Bold type** states how to avoid the hazard.
- *Italic type* states the possible consequences of not avoiding the hazard.

• Safety Symbols

A safety symbol, when present, gives a graphical description of the potential hazard, and how to avoid the hazard:



Risk of Fire



Read Instructions Before Use



Risk of Explosion



Mandatory Eye Protection



Risk of Entanglement



Mandatory Protective Gloves



Dangerous Fumes



Mandatory Protective Clothing



Do Not Pull or Move



Risk of Burns

IMPORTANT SAFETY INSTRUCTIONS

DANGER



Engine exhaust contains toxic gases.

- **Vent vehicle's exhaust away from work area.**
- **Do not breathe exhaust.**

Exhaust gases will cause injury or death.

WARNING



Improper use and operation.

- **Read, understand and follow all safety messages and operational procedures in this manual before operating this machine.**
- **This equipment should be operated only by qualified personnel.**
- **Use this equipment only as described in this manual.**

Improper use and operation of this product can result in injury.

WARNING



Engine systems can malfunction expelling fuel, oil vapors, hot steam, hot toxic exhaust gases and other flying particles.

- **Wear safety goggles and protective clothing, user and bystander. Everyday eyeglasses only have impact resistant lenses, they are NOT safety glasses.**
- **Do not position head directly over or in front of carburetor or throttle body. Engine backfire can occur when air cleaner is out of normal position.**
- **Make sure gauge reads zero before connecting or disconnecting hose connections to adapters.**
- **Make sure cooling system pressure has been relieved before connecting or disconnecting hose connections and adapters.**
- **Keep a dry chemical (Class B) fire extinguisher rated for gasoline, chemical & electric fires in the work area.**

Fire, explosion, or flying particles may cause serious injury.

WARNING

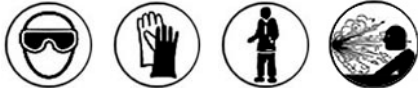

Risk of expelling pressurized fluids.

- **Wear safety goggles and protective clothing, user and bystander.**

- Engine systems can malfunction, expelling fuel, oil vapors, hot steam, hot toxic exhaust gases and other debris.
- Always unplug the machine from its power source when not in use.
- Keep the service hoses away from hot or moving engine parts. Hoses can split or burst causing fluid to be expelled.
- Avoid contact with brake fluid.
- Treatment methods are as follows:
 - Eyes: Flush eyes with plenty of water.
 - Skin: Wash with soap and water.
 - Inhalation: Move to uncontaminated area.
 - Ingestion: If large amount, get medical attention.
 - If any irritation persists, get medical attention.
- Dispose of used fluid according to environmental laws and regulations.

Fuel, oil vapors, hot steam, hot toxic exhaust gases, pressurized fluid, and other debris can cause serious injury.

WARNING

Risk of unexpected vehicle movement.

- Block drive wheels before starting vehicle's engine to begin an exchange.
- Unless instructed otherwise, set parking brake and put gear selector in park.
- Do not leave a running vehicle unattended.
- If vehicle has an automatic parking brake release, disconnect release mechanism for testing and reconnect when testing is completed.

A moving vehicle can cause injury.

WARNING



Risk of entanglement. Engine has moving parts.

- Do not place tools on fenders or other places in engine compartment.
- Keep yourself, clothing, battery cables and service hoses clear of moving parts such as fan blades, belts, pulleys, hood and doors.
- Barriers are recommended to help identify danger zones in test area.
- Prevent personnel from walking through immediate test area.

Contact with moving parts can cause injury.

WARNING



Risk of fire or explosion.

- Do not operate in the vicinity of open containers of flammable liquids such as gasoline.
- Keep hoses and jumper cables away from heat sources and sharp edges.
- Do not operate equipment with damaged cords or hoses until they have been examined by a qualified serviceman.

Fire or explosion can cause injury.

WARNING



Risk of fire or explosion. Gases produced by a battery are highly explosive.

- **Wear safety goggles and protective clothing, user and bystander.**
- **This machine is equipped to operate on 12-volt DC power only. A power source greater than this can result in serious injury to the user as well as damage to the machine.**
- **Do not smoke, place metal tools on battery or allow a spark or flame in vicinity of battery.**
- **Clean battery terminals before hooking the machine's battery clips to them. During cleaning, keep airborne corrosion from eyes, nose and mouth.**
- **Be sure both battery cables are tightly connected to the battery terminals as instructed before proceeding with a fluid exchange.**
- **Never remove battery cables from the battery terminals while the machine is operating.**

Battery explosion can cause injury.

WARNING



Risk of burns.

- **Wear gloves when handling hot engine components.**
- **Do not touch hot exhaust systems, manifolds, engines, radiators, etc.**

Hot engine parts may cause injury.

WARNING



Battery acid is a highly corrosive sulfuric acid.

- **Wear safety goggles and protective gloves, user and bystander.**
- **Have plenty of fresh water and soap nearby. If battery acid contacts skin, clothing, or eyes, flush exposed area with soap and water for 10 minutes.**
- **While cleaning battery's terminals, keep airborne corrosion from eyes, nose and mouth.**
- **Do not touch eyes while working near battery.**

Battery acid can burn eyes and skin.

WARNING



Risk of burns.

- **Wear gloves when working near hot engine components.**
- **Do not touch hot exhaust systems, manifolds, engines, radiators, etc.**
- **The fluid coming from the vehicle along with some of the machine's components that the fluid comes into direct contact with (i.e. hoses and fittings) may reach temperatures uncomfortable to the touch. Exercise caution in avoiding contact with these items.**

Hot components can cause injury or discomfort.

CAUTION



Risk of injury.

- This equipment should be operated by qualified personnel only.
- Use this equipment only as described in this manual.
- Always unplug the machine from its power source when not in use.
- Loop the power cord loosely in its proper location when machine is not in use.
- Do not operate equipment with a damaged battery cables or hoses, or if the equipment has been dropped or damaged, until it has been examined by a qualified service representative.
- Care should be taken to arrange the battery cables and service hoses so that they will not be tripped over or pulled.
- Never pull on the power cables or service hoses to transport the machine. Damage may occur to these components, or machine may tip over.
- Keep area of operation clear of unnecessary tools and equipment. Utilize recessed tool storage areas on the top of the machine.
- Never leave the machine running unattended.
- The machine is not designed for any other purpose than the servicing of automotive brake systems.

Operation of this machine by anyone other than qualified personnel may result in injury.

CAUTION

Misdiagnosis may lead to incorrect or improper repair and/or adjustment.

- Do not rely on erratic, questionable, or obviously erroneous test information or results. If test information or results are erratic, questionable, or obviously erroneous, make sure that all connections and data entry information are correct and that the test procedure was performed correctly. If test information or results are still suspicious, do not use them for diagnosis.

Improper repair and/or adjustment may cause vehicle or equipment damage or unsafe operation.

IMPORTANT

Risk of equipment damage.

- Connect battery cables to a 12-volt power source only (i.e. vehicle's battery).
- Servicing, transporting, or storing this machine in an attitude other than the normal operating position can result in fluid spillage and/or component damage.
- Never pull on the power cables or service hoses to transport the unit. Damage may occur to these components, or machine may tip over. Always use the handle to move.
- Periodically clean the machine by wiping down with a clean, soft, dry cloth.

Improper operation of equipment may result in damage to machine or components.

SAVE AND FOLLOW THESE INSTRUCTIONS!

MACHINE SPECIFICATIONS

Dimensions: 38" H x 18" W x 28" D

Weight: 60 lbs.

Waste Fluid Bottle: 4 Qt.

Power: 12V DC Power

FEATURES

The Wynn's Brake Fluid Exchange Machine provides a complete brake fluid exchange, simultaneously filling and vacuuming the brake system for a fast, effective service. It delivers brake fluid into reservoir, at same time vacuums system and reduces the introduction of air all while providing a constant supply of new brake fluid into the system..

- ✓ Complete Brake System Fluid Exchange
- ✓ Combo of Pressure at Master Cylinder & Vacuum at Wheels
- ✓ Handles High Pressure Hybrid Vehicle Brake Systems
- ✓ Pressure Regulator & Gauge for Proper Fluid Pressure Setting (1-49 PSI)
- ✓ Ease of "Remove" and "Top Off" of the Master Cylinder Reservoir
- ✓ Pressure-Free Service Hose Removal
- ✓ Up to 18' Coiled Hose
- ✓ Removable Waste Fluid Container
- ✓ Convenient, Portable Roll-Around Unit

MACHINE OVERVIEW

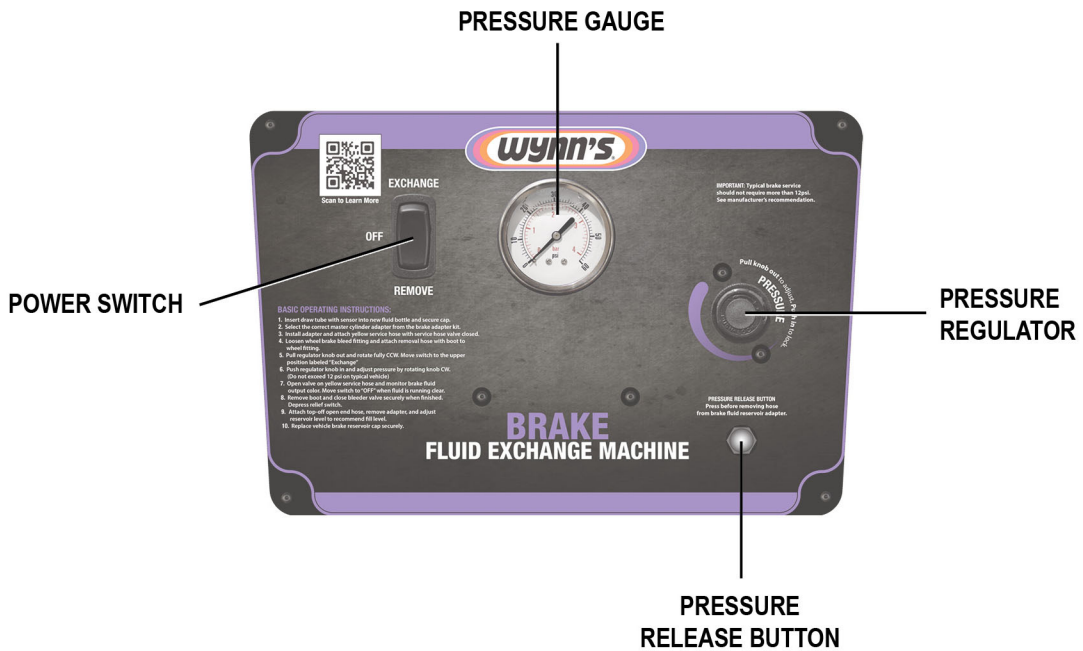
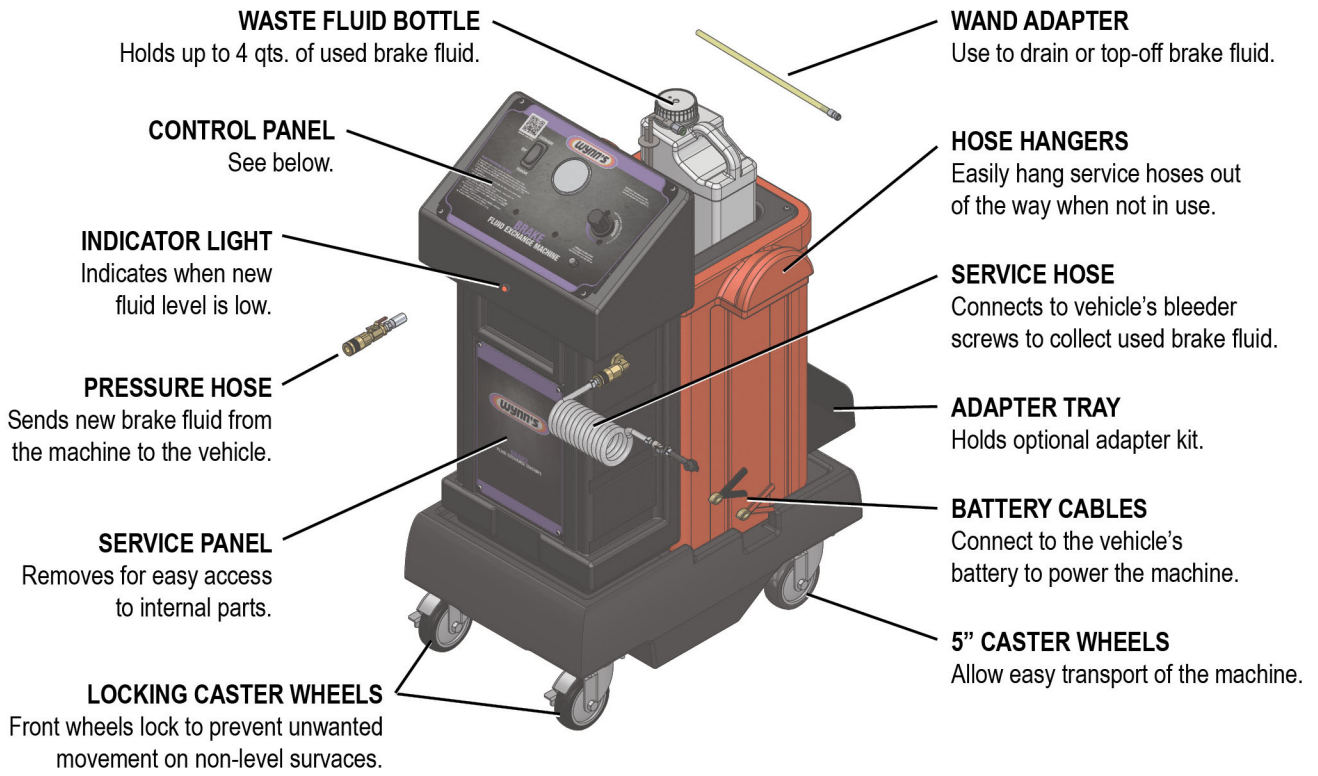

OPERATING INSTRUCTIONS

SAFETY RECOMMENDATIONS

Safety glasses and gloves should be worn during the service.

Never raise the vehicle when it is occupied.

Always inspect braking system for leaks prior to service.

Road test the vehicle to test the braking system.



PREPARATION

Confirm bleeder screws on vehicle can be opened and are not seized.

Penetrating fluid may need to be applied.

Attach brake bleed boot at the end of the fluid removal line to the bleeder screw on wheel being serviced.

Support the coiled hose using a convenient point on underside of vehicle to remove strain on boot.

Bleeder valves should be closed, but ready to be opened.

Connect battery cables.

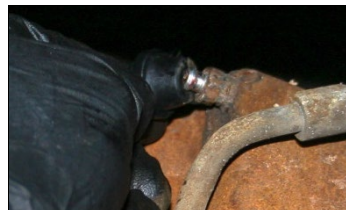

Attach **NEW FLUID** pickup to appropriate Wynn's Brake Fluid Bottle.

Remove master cylinder cap.

Attach open ended hose to coiled waste hose.

Set switch to **REMOVE** position.

Place open ended hose into master cylinder reservoir, open ball valve and evacuate **OLD FLUID**.

When empty, close valve, set switch to **OFF** position.

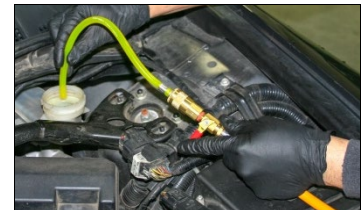

Connect open ended hose to **YELLOW** pressure hose and place in master cylinder reservoir

Set switch to **EXCHANGE** position and slowly open the ball valve.

When filled, close the ball valve, set switch to **OFF** position and remove open ended hose.



Find correct master cylinder adapter from adapter kit and attach to master cylinder reservoir.

Connect **YELLOW** pressure hose to master cylinder adapter.

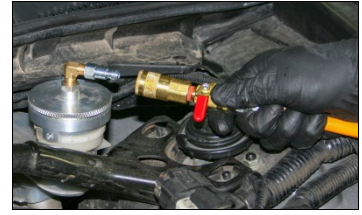

PERFORMING AN EXCHANGE

Set switch to **EXCHANGE** position.

Use the pressure regulator to increase the pressure to the desired amount. A typical brake service should not require more than 12 psi (see manufacturer's recommendation).

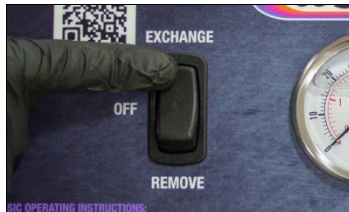

Slowly open the ball valve on the **YELLOW** pressure hose, while checking for leaks around the master cylinder adapter.

Slightly open the bleeder screw on the wheel being serviced until fluid begins to flow into removal hose.

Continue until old dark brake fluid is removed. Close bleed valve.

Repeat for remaining wheels, starting at the wheel farthest from the master cylinder reservoir and working progressively closer.



If the fluid level in the **NEW FLUID** bottle runs low, the machine will indicate this with a tone and a warning indicator light.

Set switch to **OFF** position and replace with full bottle.

Continue service by setting switch back to **EXCHANGE**.

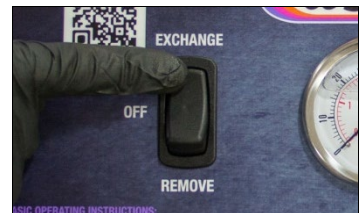

When service is complete, set switch to **OFF** position.



Press and hold the **PRESSURE RELEASE BUTTON** to relieve pressure.

Close the ball valve on the **YELLOW** pressure hose.

Disconnect the **YELLOW** pressure hose from the master cylinder adapter.



TOP OFF / REMOVE FLUID

If required, the fluid level can be raised by inserting the open-ended adapter into the end of the **YELLOW** pressure hose to fill the reservoir.

Make sure the ball valve is closed on the **YELLOW** pressure hose.

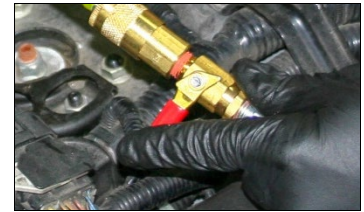
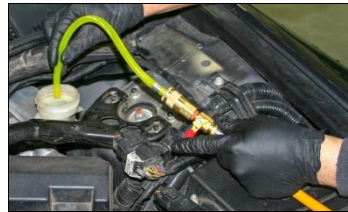

Set the switch to the **EXCHANGE** position.
Adjust the regulator pressure to 5-10 psi.

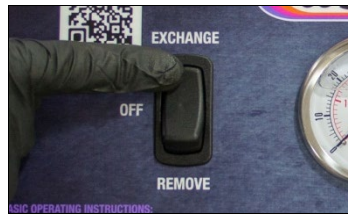

Slowly open the valve on the **YELLOW** pressure hose. Fill to desired level and close valve.

Remove pressure, then remove adapter.

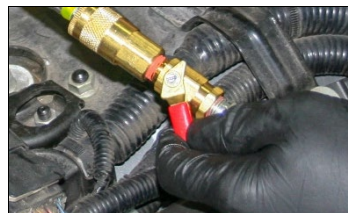

To remove fluid, use the same procedure as above, except use the removal hose to remove the fluid. Set switch to **REMOVE**, place open ended hose into reservoir and slowly open valve to remove fluid to desired level. Close valve and set switch to **OFF** position. Remove adapter.



DISCONNECT

Ensure machine is switched off and pressure is removed by pressing the **PRESSURE RELEASE BUTTON**.



Disconnect cables and hoses. Replace master cylinder cap.



MAINTENANCE

To keep your machine working properly...

- Keep debris out of new fluid.
- Avoid spilling fluid on the control panel.

REPLACEMENT PARTS

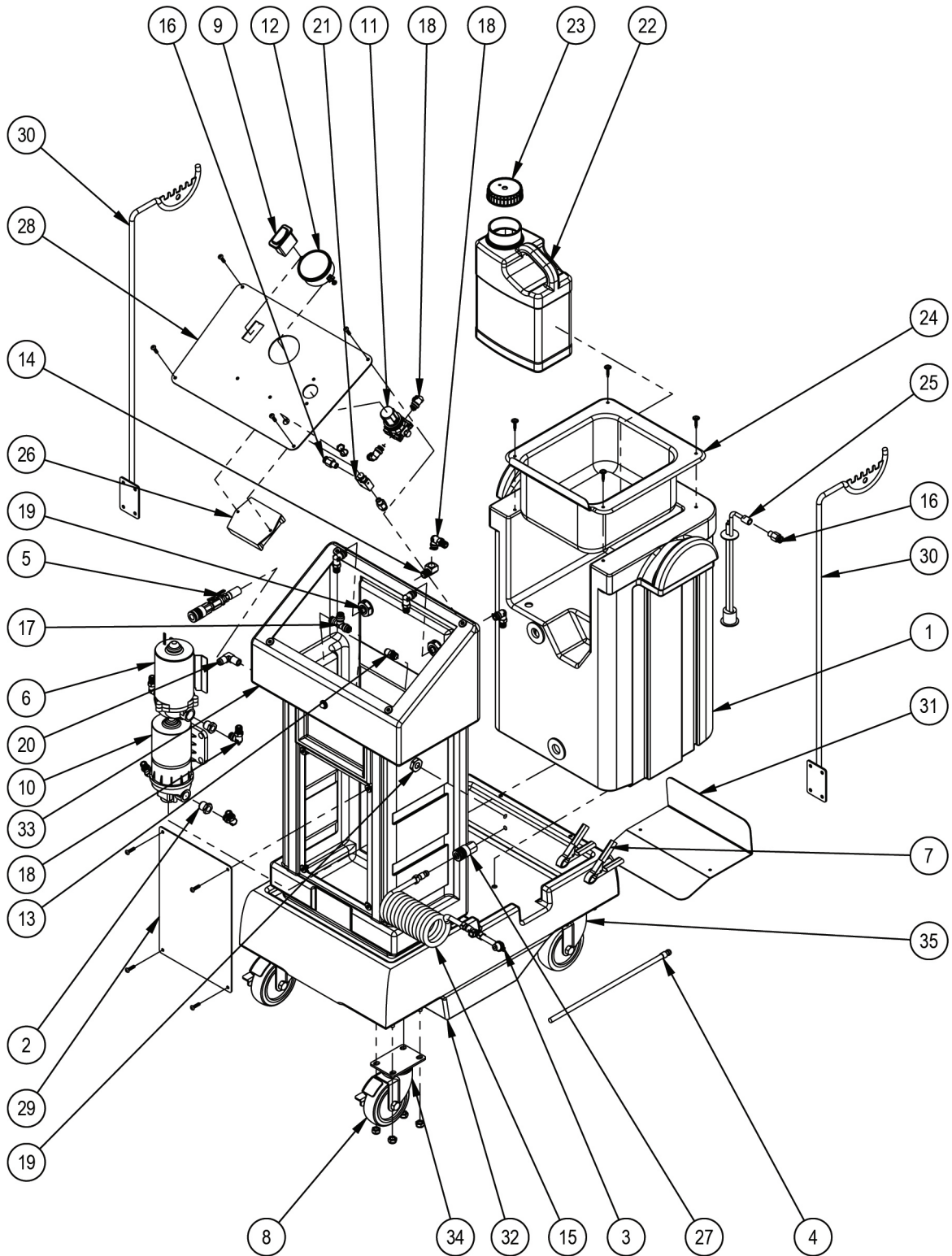

ITEM NO.	PART NO.	DESCRIPTION	QTY.
1	941252	REAR CABINET SUPPORT - RED	1
2	941447	REDUCER - 3/8 MPT X 1/4 FPT	4
3	941500	ADAPTER - BRAKE BLEED NIPPLE LARGE	1
4	941524	WAND ADAPTER - NEW FLUID	1
5	941540	YELLOW SERVICE HOSE	1
6	941545	VACUUM PUMP	1
7	941546W	BATTERY CABLES	1
8	942137W	WHEEL ONLY 4" CASTERS	4
9	944037W	SWITCH ONLY - CONTROL PANEL	1
10	945000	NEW FLUID PUMP	1
11	945002	PRESSURE REGULATOR	1
12	945003	GAUGE - PANEL MOUNT 2.5 0-60PSI	1
13	945004	FITTING - 5/16 PUSH EP SEALS	2
14	10600016	90 DEGREE ELBOW	1
15	40100074	COILED FLUID REMOVAL HOSE ASSEMBLY	1
16	40200334	5/16 TUBE X 1/8 NPT	3
17	40200336	5/16 TUBE UNION TEE	2
18	40200338	5/16 TUBE X 1/4 NPT ELBOW	10
19	40200339	1/4 BRASS BULKHEAD FITTING	4
20	40200340	3/8 JIC MALE X 1/4 NPT ELB 6 CTX-S	1
21	40200343	VALVE WITH SWITCH	1
22	40200438	1 GALLON WASTE FLUID BOTTLE	1
23	40200439	CAP FOR 40200438 WASTE BOTTLE	1
24	40200440	2 GALLON MOLDED TRAY	1
25	40200444	LEVEL SWITCH	1
26	40200445	ELECTRONICS PACKAGE	1
27	40200662	1/4 X 1/4 SLEEVE LOCK HOSE SOCKET	1
28	40300297	CONTROL PANEL - OVERLAY ASSEMBLY	1
29	40300304	SERVICE PANEL - OVERLAY ASSEMBLY	1
30	P941530	SHEPHERD HOOK - BLACK	2
31	P941538	ADAPTER BRACKET - BLACK	1
32	R940750	CHASSIS - BLACK	1
33	R940751	CONSOLE - BLACK	1
34	R942118	CASTER 4" W/BRAKE	2
35	R942137	CASTER 4" SWIVEL	2

Wynn's Equipment Limited Warranty Terms and Conditions

(1 Year on Equipment / 2 Years on Parts)

Seller warrants to its distributors that under normal use, care and service, the Equipment (except as otherwise provided herein) shall be free from defects in material and workmanship for One (1) year from the date of original invoice (unless a machine was put into inventory and later sold (such sale from inventor to occur no later than [six (6) months] after the date of original invoice), and a distributor can provide proof of sale and registered warranty card, then the one-year warranty will begin on the registration date) for all Equipment with an additional 12 months of coverage for **parts only**. External hoses, remote control modules, adapters and all other attachments, supplies and consumables (except as otherwise provided herein) are warranted for 90 calendar days from the date of original invoice. Filter elements are not warranted. Printed circuit boards purchased from Seller will be warrantable for a period of one (1) years from original purchase date, and any repair services for machines under warranty or to a purchased circuit board by an ITW employee or authorized representative shall be reimbursed.

SELLER'S OBLIGATIONS UNDER THIS WARRANTY ARE LIMITED SOLELY TO THE REPAIR OR, AT SELLER'S OPTION, REPLACEMENT OF EQUIPMENT OR PARTS, AND LABOR COSTS ASSOCIATED WHICH TO SELLER'S SATISFACTION ARE DETERMINED TO BE DEFECTIVE AND WHICH ARE NECESSARY, IN SELLER'S JUDGEMENT, TO RETURN THE EQUIPMENT TO GOOD OPERATING CONDITION. NO OTHER WARRANTIES EXPRESS OR IMPLIED OR STATUTORY, INCLUDING WITHOUT LIMITATION ANY IMPLIED WARRANTY OF MERCHANTABILITY OR FITNESS FOR A PARTICULAR PURPOSE, SHALL APPLY AND ALL SUCH WARRANTIES ARE HEREBY EXPRESSLY DISCLAIMED.

This warranty does not cover (and separate charges for parts, labor and related expenses shall apply to) any damage to, malfunctioning, inoperability or improper operation of the Equipment caused by, resulting from or attributable to (A) abuse, misuse or tampering; (B) alteration, modification or adjustment of the Equipment by anyone other than Seller's authorized representatives; (D) improper or negligent use, application, operation, care, cleaning, storage or handling; (E) fire, water, wind, lightning or other natural causes; (F) adverse environmental conditions, including, without limitation, excessive heat, moisture, corrosive elements, or dust or other air contaminants, radio frequency interference, electric power failure, power line voltages beyond those specified for the equipment, unusual physical, electrical or electromagnetic stress, and/or any other condition outside of Seller's environmental specifications; (G) use of the Equipment in combination or connection with other equipment, attachments, supplies or consumables not manufactured or supplied by Seller; or (H) failure to comply with any applicable federal, state or local regulation.

Repairs or replacements qualifying under this Warranty will be performed on regular business days during Seller's normal working hours within a similar timeframe and process as BUYER already has in place, to be accomplished by Wynn's/QMI distributors with the support and cooperation of the SELLER, or by SELLER or SELLER's subcontractors if that is acceptable to the BUYER following Purchaser's request or if agreed to between Seller and Buyer by Purchaser's/ ITW staff if necessary. All requests for Warranty service must be made during the stated Warranty period. **This warranty is non-transferable.**