

drilling machinery

**S-BEAM
DRILL
LINE**

OYS  **On Your Side**



Professional Solutions

www.oysmak.com

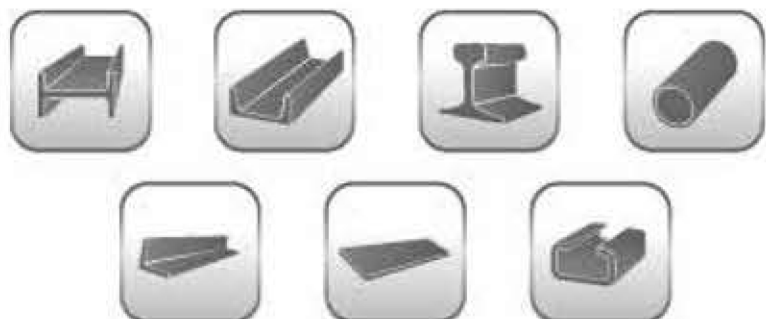

**S - BEAM SERIES
PROFILE DRILLING
SOLUTIONS**

- Profile drilling machine on single face by turning beam
- UPN Profiles - DIN 1026
- IPN Profiles - DIN 1025
- Box Profiles
- 40 - 600 mm special profiles with acceptance by OYSTEAM
- Special Plate Drilling
- No limits on length, machine can be extend according to customer request.

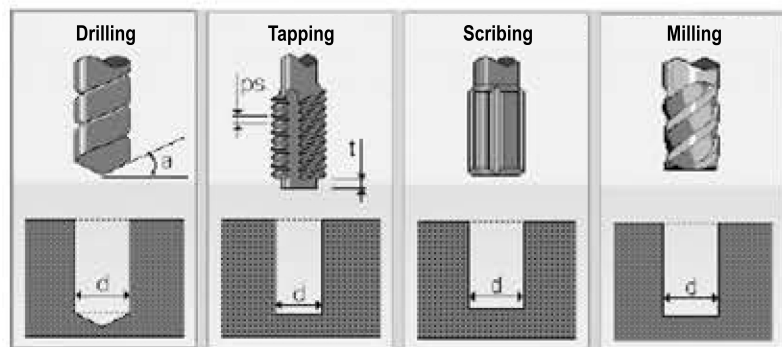

S-Beam profile drilling machine is for all structural steel producer and steel fabricator small to big ones.

- Eliminates manual operation - layout and drilling
- Provides greatest accuracy and eliminate costly field modifications
- Half floor space especially for competitor models
- Simple and easy operation no require additional software
- No required high-skilled person
- Full automatic drilling system from drill to tapping the beam or plates
- Lower investment for fabricator

MULTI - PART PROCESSING

S-Beam has capability to process more than one part in order. If workpiece length is less than machine working length then operator can place couple of workpiece and machine drills one by one - during this period of time operator can place other workpiece according to shift plan.



WORK-PIECE DETECTION AND TOOL LENGTH

Placed workpiece is detecting by laser and related macro program takes the first detection point as reference and accordingly starts the program and look for next workpiece if it has programmed before. Therefore without any waitings each parts one by one detected by laser and S-Beam processes the workpiece due to program.



BIGGEST ADVANTAGE

S-Beam does not require move for each drilling in 400 mm envelope that means 15" gap.

- Quick drilling close hole to hole
- More accuracy
- Scribing capability
- Milling or Slotting capability





CARBIDE DRILLING

Versatile high-performance solid carbide drill that can be used across a wide range of materials. With one drill for different materials, stock holding can be reduced and greater machine flexibility is offered leading to reduced set-up time.



ACCURATE AND QUICK DRILLING

Monoblock frame has strong rigidity and four axes on linear guides accelerate with high performance servo motors. Unique design structure equipped with ball-screw system helps to positioning faster and accurate drilling.



This rigid solution leads to have greatest drilling, tapping and milling.

TAPPING FEATURE

Capable to tap from M8 to M24 with outer coolant without any heating that prolonger the tooling life and machine parts.



FACE SCRIBING

This feature comes most of the competitor models as option. However S-Beam provides this feature as standard to structural fabricator that works with only special pneumatic scribing tool to make number, special shapes, welding and connection points and marking your own codes to help you in the installation field.



HYDRAULIC PRESS DOWN

Drilling process is applied high torque on the material with specific feedrate and revolution that occurs a vibration on the material and workpiece has to hold strongly therefore good quality drill and other process can be performed.



AUTOMATIC TOOL CHANGER (ATC 6 -TOOLS)

Tool changer detects the new tool loading and machine automatically register tool with specific tool length that helps operator and save time - also not allow mistakes to do crash accidently.



MOBILE CABINE

Cabine has equipped with CAT-4 safety systems & stops if touches anything an expected human moves or materials - it doesn't effect from the chips.



WHY S-BEAM?



HALF FLOOR SIZE



HALF PRICE



DOES ALL

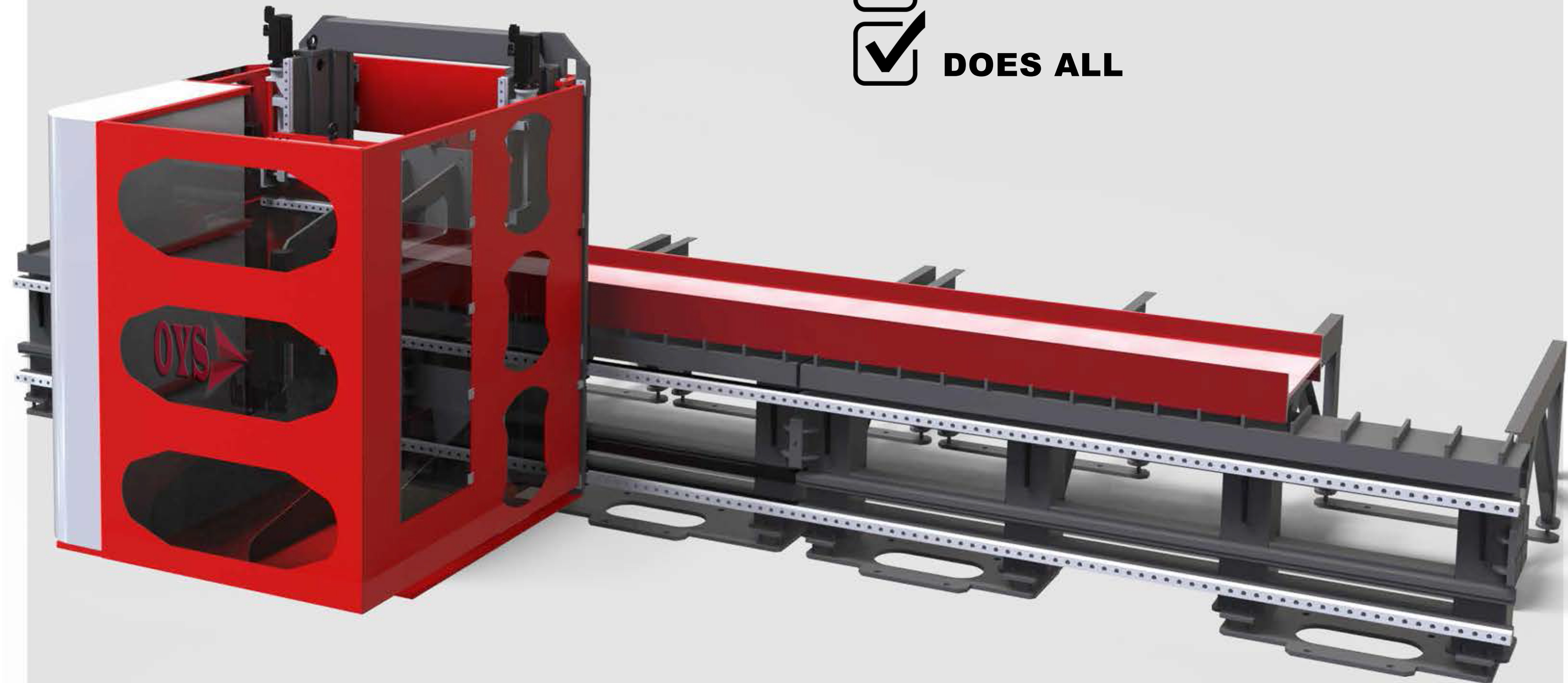

AUTO LUBRICATION

Centralized grease lubrication system, an ALS automatically lubricates multiple points on a machine from a centralized pump/control unit, which is mounted in an easily accessible location that automatically greases 21 points, helps eliminate these unplanned and unnecessary expenses.



STANDART FEATURES

- Siemens controller and software
- Drilling, tapping, milling, scribing operation
- Automatic referencing over the part
- Auto tool changer 6 - tools
- High - Speed Carbide Drilling
- Internal and External Coolant
- Mist Coolant - Clean Part
- ALS Auto Lube System
- Online Trouble Shooting

FLOOR PLAN

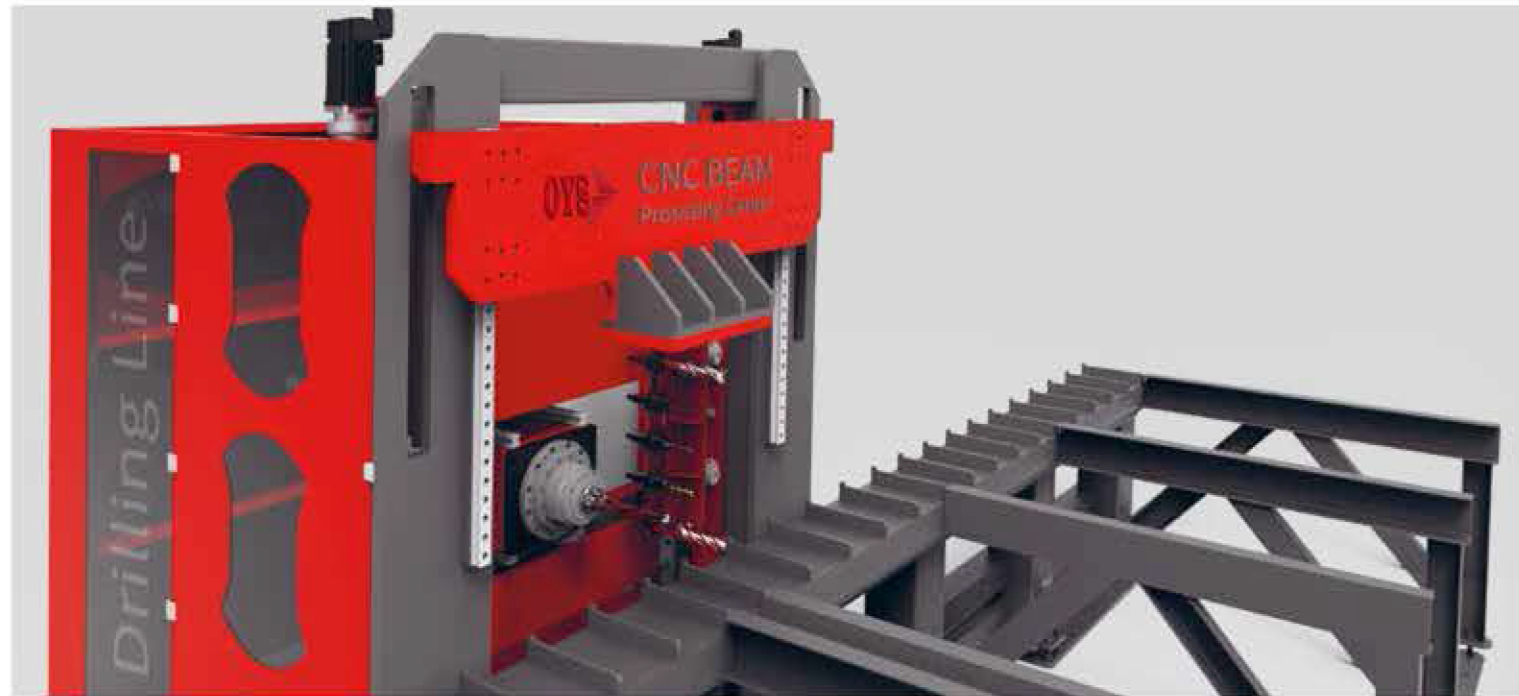
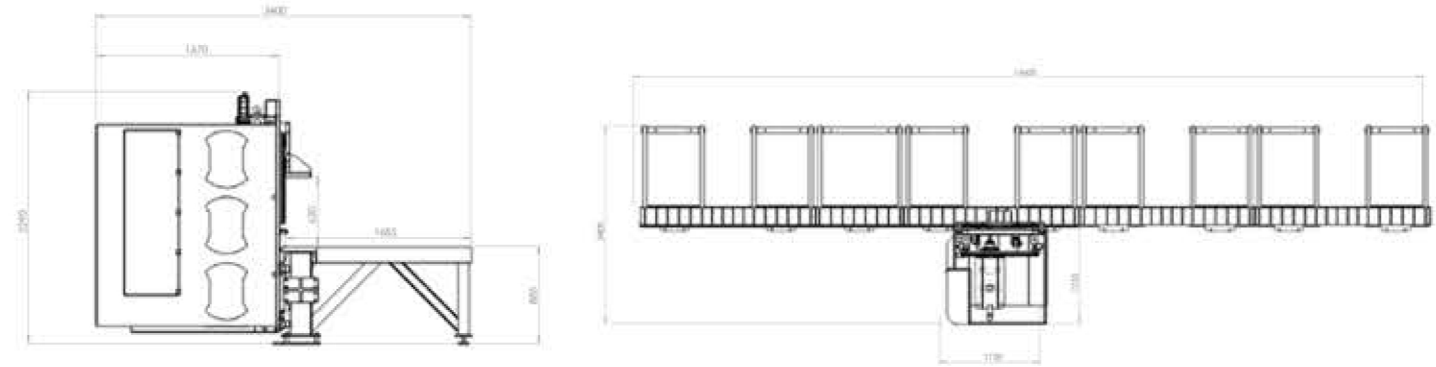

COOLANT

Having a correct coolant supply is crucial in order to achieve successful performance in drilling. The coolant supply influences:

- Chip evacuation
- Hole quality
- Tool life

Internal coolant is always preferred to avoid chip jamming, especially in long chipping materials and when drilling deeper holes.

External coolant supply can be used milling, tapping and countersinking operations. It may also used for drilling but it should be close enough tool.

Dry drilling is not generally recommended.

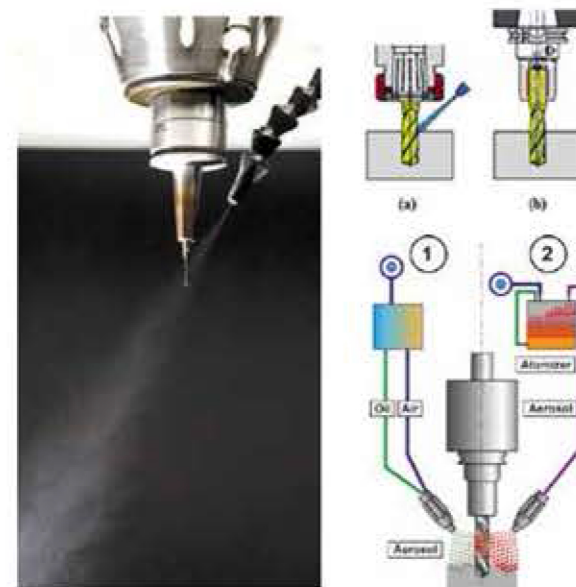

Specifications		S-BEAM	
Profile Height	mm	40 - 600	
	inch	1 -1/2" - 24"	
Profile Length	mm	40 -6000 and More	
	inch	1-1/2" - 240" and More	
Table Size	mm	0 -1250	
	inch	0 - 50"	
Working Height	mm	900	
	inch	35"	
Max Loading Capacity	kg / m	350	
	lbs / ft	250	
Positioning and Drilling		Servo Motors	
Spindle Power	kW	11	
	Nm	120	
Drill Holder		BT 40 - SK 40	
Spindle Speed	rpm	3000	
Drill Diameter	mm	5 - 40	
	inch	1/4 - 1,58"	
Tool Changer		6 tools	
Tapping Capacity		M8-M24	
Cabin weight	kg	1650	
	lbs	3520	
Machine Weight	kg	8.100	
	lbs	17.820	



OYSMAK

On Your Side

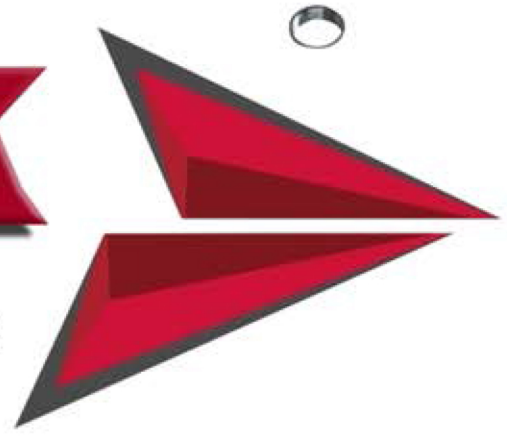

DRILLING
MACHINERY

Factory

Yaylacık Mahallesi, Yaylacık Köyü İç Yolu No:21 16110 Nilüfer /BURSA
oys@oysmak.com

 +90 530 875 07 08

