

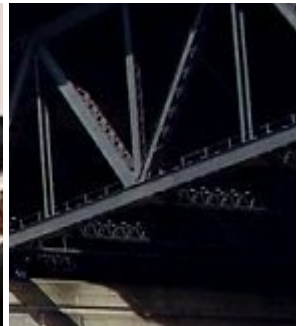

Lamson Concepts

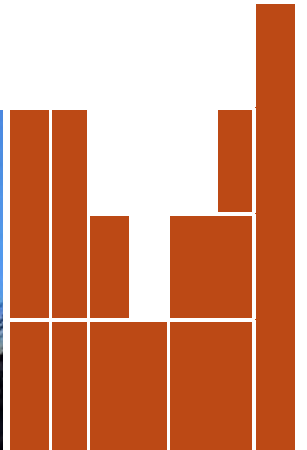

company profile





Table of Contents

Board of Directors	2
Who is Lamson and what do they do?	3
Our History	4
Community and Environment	5
Our Clients	6
Our Product Range	7
Air Tube	8
Lamson 600 Series	9
Lamson 750 Series	10
Lamson Cashguard	11
Lamson Whizair	12
CAST (Casino Automated Secure Transport)	13
Lamson AC3000	14
Lamson Multilift	15
Lamson Multilcar	16
Lamson Junior Lift	17
Lamson Service Lift	18
Lamson Transcar	19
Lamson Unicar	20
Lamson Electronic Article Surveillance Systems	21
Electronic Article Surveillance Systems Accessories	22
Lamson Trolleyguard	23 - 24
Lamson Tank	25 - 26
Lamson Customer Testimonials	27
Quality Assurance	28
Lamson Australia Wide	29
Lamson World Wide	30

Board of Directors



Raymond S Louis
Director/Chairman

Mr Louis was appointed as the Chief Executive Officer in April 1999. He had been acting Managing Director of Lamson Concepts for two years prior. Mr Louis has a broad career in the aviation industry as well as insurance and business consultancy. He holds distinguished achievements in business restructuring and sits on the boards of private and public companies. Mr Louis is also the chairman of Tank Security Pty Ltd and has commercial interest in hotels and real-estate.



Malcolm J Menday
Director / Managing Director

Mr. Menday took over the Managing Director role in April 1999 and joined the Board at the same time. As an executive, Mr Menday has been working in the Lamson Group for more than 18 years in the electrical and building engineering industries. Mr Menday is instrumental in developing Lamson's international extensive operations as well as research and development of Lamson systems. Continuous improvements and strategic planning are some of the strengths Mr Menday brings into the role which has seen Lamson Concepts gradually increase its size and operations since 1999.



Raj Prasad
Director / General Manager

Raj Prasad was appointed director in 2004. He joined Lamson in 1998 and has held a number of commercial positions within the company. Raj concentrates on corporate matters, re-engineering business process and also involved in business growth strategies. He holds Bachelor of Commerce degree and a Diploma in Business, from the University of Western Sydney and is a member of the Society of the CPA Australia.

Who is Lamson and what do they do?

Lamson Concepts is a national loss prevention and material handling company, borne out of the previous identity, Lamson Engineering which was established in 1898. The company steeped in history having been operating in Australia for over a century.

Lamson is the largest manufacturer of airtube systems in the Australasian and New Zealand region. Coupled with the world renowned Telelift and Transcar product range virtually guarantees that Lamson will form the ideal partnership with any organisation seeking a materials handling or security solution.

Lamson cover the vast continent of Australia with branch offices located in the state capitals with the head office being located in Regents Park, Sydney. Specially trained agents provide services throughout Australia including remote regions.

Continued development of cash pick-up has formed partnerships with armoured cash security companies and other related organisations including retail loss prevention. You can be assured that Lamson is at the forefront of cash handling and security technology.

We encourage a culture of safety and safe work practices. We are genuinely client focused and continually seeking improvements in our products. We are determined to succeed and draw inspiration from challenges. Our philosophy is provision of value adding solutions and their timely and cost effective service.

Lamson provide professional service and advice. All our staff are highly trained and have many years of experience and they are always available for all your queries and requests.

To receive a quote, further information or advice, Lamson invites you to contact our head office.



Locked Bag 1
Regents Park, NSW 2143



Toll Free: 1300 130 933
Fax: (02) 9743 8569



Unit 7, 14-38 Bellona Avenue
Regents Park, NSW 2143
(02) 9743 7322



www.lamson.com.au

Our History

Lamson was established in Australia in the year 1898. The doors were opened for trading by Mr C O Kemp on the 28th of September. The idea of a "store service system" originated in the United States in 1879. Drapery store owner, William Stickney Lamson, became aware of the time and effort wasted by shop assistants taking customers' money to the cashier and returning with change. William Lamson realised that there had to be a better way.

Early ideas involved tying cash and bills in a handkerchief and "throwing" it to the cashier which proved to be unsuccessful to a great extent. The end results of his effort was the Ball System. This is where a hollow ball, containing the money, rolled on an inclined track from the shop assistants' counter to the cashier. The cashier also had an inclined track that rolled the change back to the assistants' counter.



The move across the Atlantic of Lamson's "Ball System" was instigated by a Mr John Kelly who obtained the rights in the United Kingdom to Lamson's invention. In 1885, from a small private hotel in Craven Street, London, the Lamson Consolidated Store Service Company commenced trading. By 1889 some 3,725 station "Ball Systems" were operating in the UK.

Another invention called the "Rapid Wire System" was later introduced which automated the "Ball System" to a certain degree. For the next 50 years Lamson's "Rapid Wire System" or as it was affectionately known, "Flying Fox" would zoom across ceiling spaces of stores throughout Australia. Many a small child lugged along by Mum on a shopping safari, was fascinated by these "Flying Foxes".

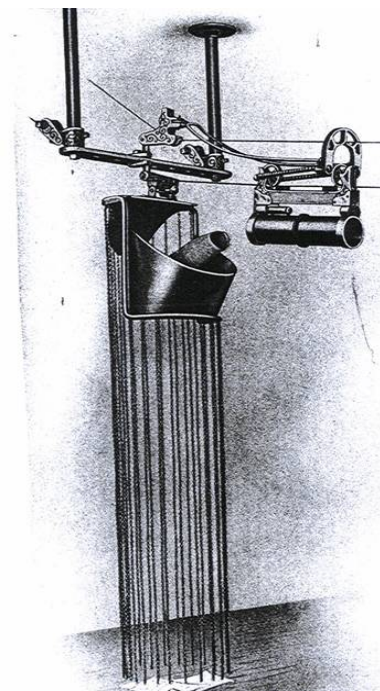

Lamson systems have been part of the changing pace of Australian business for over 100 years. They have been an integral part of the nation's retail, hospitals and other commercial and government sectors. Thousands of Lamson systems have been installed, some original systems installed like the National Library in Canberra is still operating today. As time changes, Lamson is more than confident that the products and services they have, and those still in the research and development phase, will continue to carry the proud tradition.

Community and Environment

Environment

Lamson is committed to the management of all its business operations in an environmentally responsible manner. A strong compliance framework exists within the group with the objective of achieving best practise environmental management. In line with community attitudes and expectations there is a strong emphasis on achieving sustainable development and protecting the environment.

Donations/Sponsorship

Lamson are generous donators to many of the customers and hospitals that use their products directly and indirectly.

On a sponsorship level Lamson have been involved with:

- Rugby League
- Race days
- Golf days
- Motor Racing
- Surf Clubs

Objective

The overall objective of Lamson's donations and sponsorship policy is to enhance its reputation as a good corporate citizen by making direct contributions to the community in addition to the general economic benefits flowing from its activities.

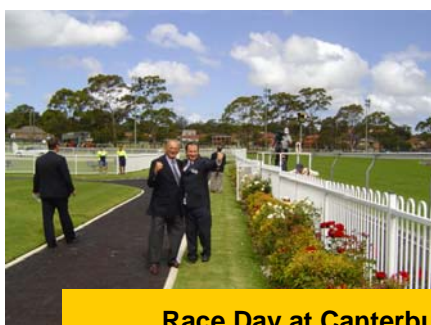

Race Day at Canterbury

Lamson Bulldogs Cheergirls



Our Clients

Lamson have many clients in a diverse range of industries. Our clients are all supplied with a system that best suits their own requirements.

Retail

Lamson has a variety of products and solutions to suit all retail chains from small to large. Our clients include large blue chip clients such as:

- Myers Group
- Big W, Woolworths
- David Jones
- Bunnings Warehouse
- Coles, Bilo, Kmart, Target
- Franklins
- Action Supermarkets
- IGA Supermarkets
- International - Walmart
- Drexeline

We also offer systems for petrol stations and smaller independent operators. Whether it's cash security, cash transfer, EAS, trolley management issues that are bothering you, Lamson will provide the one stop shop to supply the solutions. We design our systems to suit your needs.

Hospital & Healthcare

Lamson healthcare solutions support the optimization of the logistics processes in hospitals and pharmacies, resulting in greater efficiency and significantly reduced costs.

Lamson focus lies on improvement of the internal transport processes. This includes transport solutions for laundry, food, blood and tissue samples as well as solutions for automated drug handling. These transport solutions are in the form of Pneumatic Tube systems, Rail Bound Conveyor systems, Service Lifts and Automatic Guided Vehicles.



Some of our hospital clients include Westmead Children's, John Hunter, Nepean, St Vincents, Royal Brisbane, The Alfred Hospital, Flinders Medical Centre and Royal Perth Hospital.

We also provide products to the industrial, pubs & clubs, entertainment venues, transport services and households.

Our Product Range



Carriers

Lamson have a wide range of products to provide which include:

- Air Tubes
- Electronic Article Surveillance Systems
- Rail Bound Conveyors
- Trolleyguard
- Service Lifts
- Automatic Guided Vehicles

Lamson designs each system to meet individual requirements and requests.

And through Tank Security — a Lamson controlled company:

- Safes
- Coin/note Dispensers
- Automatic Entry Gates
- CCTV
- Alarms & Monitoring systems

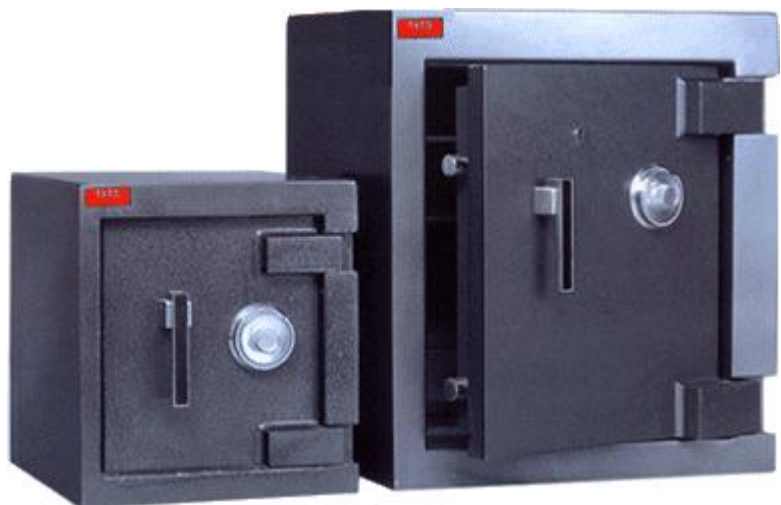

Anti Burglary Safes

Air Tube

Our core products are the Airtube Systems. These are designed for moving cash, documents, or products to as many individual destinations as required at the touch of a button.

Safe and reliable transfer of critical items.



For many years a number of major hospitals have relied on Lamson systems to transfer specimens and blood for urgent analysis between operating theatres, pathology, x-ray and other support departments.



Send station when opened

- Lamson systems are cost effective, reliable and tamper proof. Hot materials, toxic and hazardous substances are successfully transmitted through Lamson air tube systems at industrial companies.
- Steel plants rely on Lamson systems to transmit hot samples from the foundry
- Many retailers, cinema complexes, supermarkets and shopping centres are turning to Lamson for the provision of safe, reliable and secure transmission of cash.
- Lamson have a number of options designed specifically to satisfy the stringent requirements of a variety of customers.
- World class airlines such as Qantas, Air New Zealand have been using Lamson for decades to send parts between departments.

Lamson 600 Series™

- Lamson 600 series was designed to automate the transfer of cash.
- It is extremely reliable and still a preferred option for many customers.

Help menus, resend/retry functions, new wiring specifications and a dynamic state of the art microprocessor are features which turn into real benefits for staff and management. There is a wide range of pre-programmed messages that cover almost every situation, for example:

- emergency/duress signal for customer and staff safety
- close register signal
- send cash signal
- send cash
- awaiting cash



Vacuum sealed safe

Help menus provide a friendly user guide at the registers and a trouble shooting guide at the cash office.

Working specifications have been upgraded for maximum performance and reliability standards. Communication and power cables are separated to prevent interference from high voltage lines and fluorescent lighting systems.

Communications between the receiving station and the send station are faster than ever. System memory loss and failures are virtually a thing of the past, thanks to a new software protocol. It also has an integral protection against communication “hang up” during lightning storms.

References: Woolworths/Safeway, Big W, Pick N Pay, Bi-Lo

Lamson 750 Series TM

Lamson 750 Series

Take care of your hard earned cash!

Make operators more accountable via a fully printed audit trail.

Lamson 750 Series has a number of features, some of which are:

- Audible alarms
- Time and date display
- Resettable transaction counter
- 'In Queue Please Wait' indicates to the operator that another transaction is underway.
- Up to 24 operators and PINS available
- Service Mode – enables service personnel to check and find faults quicker.
- One send station can recognise many cash register identities.
- Various levels of access/authority
- A separate supervisor's control panel for audit trail functions and printable data.
- Printer supplied



The Parachute Bag Revolution

Although the use of parachute Bags has been in the market place for some time, it is now that the major retailers have well embraced the concept. Some of the advantages of using parachute bags are as follows:



Parachute bag being inserted into a send station

- Hundreds of cash filled bags can be sent either directly to a vacuum sealed safe or laminated receiving cabinet.
- As with any commodity that becomes mainstream, the price per bag is very low, compared to hard carrier system.
- Bag systems do not require a secondary system to return empty carriers, a significant saving for the user.
- A parachute system is much more reliable.
- Paracjite bags do not create wear and tear on the system that hard carriers do.
- Frees up space in and around the checkout areas as there is no need to store hard carriers.
- Requires less motor power due to low weight.
- Can be hooked onto Lamson Cashguard system with ease.

References: Coles Supermarkets Franklins, Myer, Bunnings, Action Supermarkets

Lamson Cashguard™

The Cashguard system is designed to transfer bags of cash (referred to as “Parachute Bags” which are disposable and minimum cost) once removed and counted from the safe within a security/cash room inside a building directly into an armoured car parked outside the building via a single tube run.

The benefits are a safe, secure and efficient transfer of large amounts of cash without the need for armed security officers to carry large volumes of cash in public areas, reducing the risk of serious injury (or worse) to security personnel, store staff and the general public.

Cashguard reduces the public liability and Cash in Transit risk that threatens many retailers today.

- Extensively used in Australian Supermarkets
- Extensively used in cash carry Companies

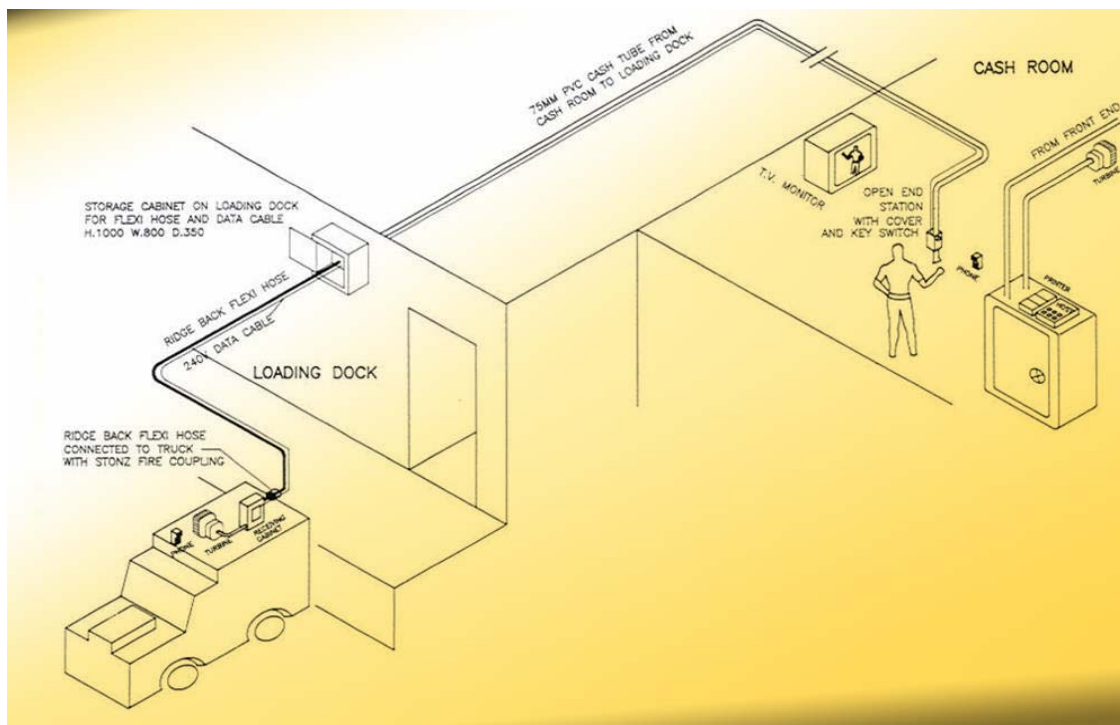

If you are serious about safety and security—think Cashguard

References: Coles Supermarkets, Bilo Ltd

Lamson Whizair

Whizair airtube transfer is used for connecting any two workplace locations. Readily adapts to new or existing work sites. Installation can be in-ground, above ground, within false ceiling confines or even wall cavities.

Features:

- Low cost
- Reliable
- Hot or cold payload
- Range of carrier sizes to fit payload
- Optional remote monitoring
- Simple one-step, push button operation

Transfer:

- Coins, cash - retail stores
- Specimens, samples - medical/pathology
- Sales docket, requests - shops/sales outlets
- Delivery docket, receipts - warehouse / industry
- Small parts = maintenance/workshops
- Hot samples, powders - metallurgy



A concrete plant driver attending to the paperwork



Whizair slide station and carrier

Technical Data:

Tube diameter 60-300mm
 Material: heavy duty PVC or steel
 Curve radius: from 400mm
 Distances: infinite, 200 metres typical
 Speed: 25 km/h
 Turbine single or 3 phase (1kw typical)
 Weight: 1kg, 2.5kg, 5 kg

Clients include:

Coles Myer, Commonwealth Bank, BHP, ST Vincents Hospital, News Limited, Ansett, Parliament House, FAC, Sea World, IMAX, Gladstone Smelter, Benarra Nursery, Sydney City Toyota, Greater Union, Readymix, Pronto, Kodak

C.A.S.T (Casino Automated Secure Transport)

Lamson systems are widely accepted and used in Casinos around Australia. If your business has problems with moving or transferring items, cash, chips and gaming cards from one location to another, then Lamson may have a solution for you.

Some systems have been in operation for some time now however commitment to research and development has seen Lamson develop a system for the transfer of items between:

- Gaming pits
- Cash cage
- Soft count
- Hard count
- Card pre-shuffle
- Bars
- Other cash or document collection points



Gaming table at Jupiters Casino

The CAST system includes a number of components joining sections of the casino together. A supervisory centre and master control forms part of the package. Special security containers are employed to transport the different loads.

CAST eliminates manual collection of 'drop' boxes, enhances security through gaming area, automatically transports cash, chips, cards, documents to and from gaming area, reduces labour and security costs and enhances customer gaming experiences.



Chips



Lamson AC 3000



All stations can be connected to a pneumatic tube system. For example in a hospital environment the laboratory, reception, blood centre, theatres, central pharmacy, pathology, care stations, nurses room and all supporting areas and facilities such as administration and the kitchen. All types of documents, reports, patient histories, X-rays, medicines and drugs, lab specimens, blood plasma, injection vials and instruments are suitable to be transported in the pneumatic tube.

Furthermore, also dictating tapes for the typing pool, (new) meal requests/changes to be sent to the kitchen, mail and reports to and from administration can also be transported using a pneumatic tube system.

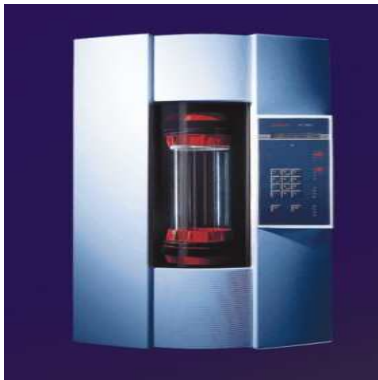

The AC 3000 sending and receiving stations are based on a concept that has been perfectly adapted to the demands of a modern hospital. The standard of the AC3000 includes a storage facility for automatic dispatch, pneumatic brakes to decelerate the arriving carriers and various speeds can be individually adjusted for transporting delicate goods.

In compliance with the health regulations, there is no air exhaust during the sending and receiving operations. The central PC automatically controls the entire operation. Recording the processes enables an exact evaluation and analysis.



References: Royal Brisbane Hospital, Greenslopes Hospital, Sutherland Hospital, St George Hospital, Geelong Hospital, Queen Elizabeth Hospital

Lamson Multilift

Multilift is a system for the transport of standard containers with typical dimensions of 600 x 400 x 350mm. For the vertical transport, fully automatic container lifts of paternoster type or simple linear goods lifts are used, depending on the required transport capacity. Horizontal connection is achieved by belt and roller conveyors.

Because of the silent running of Multilift components it is also often used in libraries and offices.



Conveyor delivery system sending

After setting the destination at the coding system on the container it is placed in the sending station.

The modern electronic system control then ensures the fully automatic transport, if necessary including handing over to lifts in the layout. When reaching the target station a respective arrival signal is activated.



Linear lift container arriving at station

Technical Data

Payload: max 70 kg

Linear lift:

conveying capacity max. ca. 100 containers/h

Paternoster type lift:

conveying capacity max. ca. 450 containers/h

Horizontal conveying

capacity max. ca. 900 containers/h

Different types of Multilift containers



References: South Australian Library, St Vincents Hospital, ANZ Bank

Lamson Multicar

Multicar is an electrically driven monorail system which can undertake transport horizontally, over various gradients and in vertical track.

Small radii in the curves and bends of the aluminium profile allow its adaptation and use in confined spaces and restricted installation conditions.

Loading of the goods to be transported can be carried out either manually or automatically. Load carrying devices are designed to the client's specific requirements.

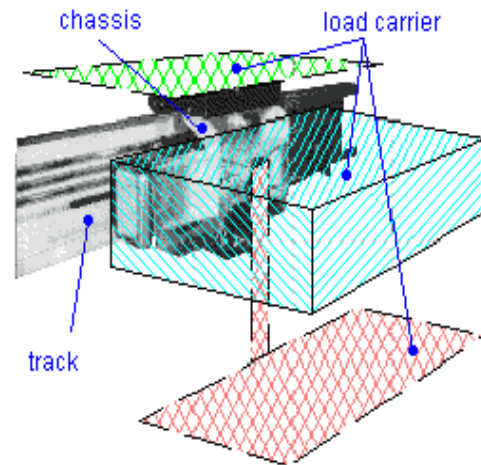

Multicar in transit



System controls can be stand alone or may be integrated into existing data processing systems as required.

Load carrying devices - can be gimballed platform, rigid box or customer specific.

Technical Data:

Max. Payload horizontal: 60 kg

Max. Payload vertical: 30 kg

Climbing ability: 90°

Speed: up to 1 m/s

Bidirectional identical travel behaviour

Multicar waiting to be loaded

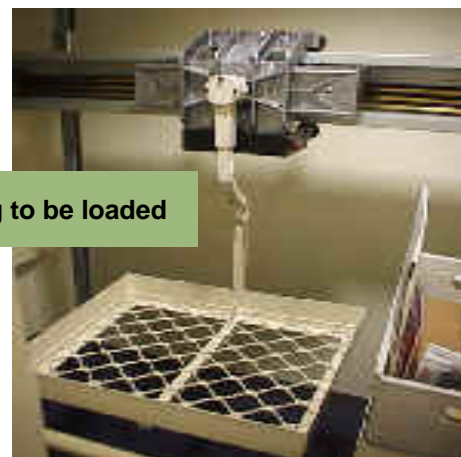

References: Myer, Australia Post, Wittners Shoes, Nike, Treasury Casino (QLD), Legal Aid

Lamson Junior Lift

The simple and economical Multi-floor document Transport System

The Lamson Junior lift is primarily designed for the transport of documents and small articles up to the size of around two telephone directories or a carton of beer (double carriage).

The lift is capable of lifting up to 1 kilogram payload between single or multi-floor levels, with up to 6 floors at any one time able to be accessed.

For over 20 years the Junior Lift has proven a valuable, time saving asset in Banking, Legal, Insurance, Government, Financial and other commercial organisations, where internal routine paperwork is required to travel between a number of floors.

Self-contained, the Junior Lift can be positioned virtually anywhere, occupying minimal floor space and simply plugging in to any 240 volt power outlet.

Operation is safe and simple with stations for Despatch/delivery located on each level. Each station has a 'smoked' Perspex hinged door which is fitted with a safety interlock system stopping transport instantly should any door be opened. As an option, reverse doors are available hinged on the right hand side (when facing the front of the lift)

Push button controls at each station provide for Car Call and Car Despatch to the desired destination. Option acoustic or light signals may be installed to announce the arrival of the car at each Station.

The Junior Lift car is an open top container which allows quick access to the contents and will easily accept large ring binders. For special applications, an optional tilting car can provide increased access.

The silent drive unit is safely incorporated into the bottom station and only requires a 240 volt outlet close by. The lift is operated by a quiet and reliable drive motor which is fitted with a thermal overload to protect the complete system, in the event that the Lift is overloaded.

Because the Junior Lift is self supporting, it is suitable for face or recessed wall mounting or even as a free standing unit. The compact casing required only a small opening through the floor.

The self supporting casing is a specially designed lightweight aluminium channel section which accommodates the car, cable and electrical interconnection.

The Lamson Junior Lift is attractively designed to enhance any office décor, standard casing finishes being white Sahara vinyl coated, Marvplate steel or smart Stainless Steel.

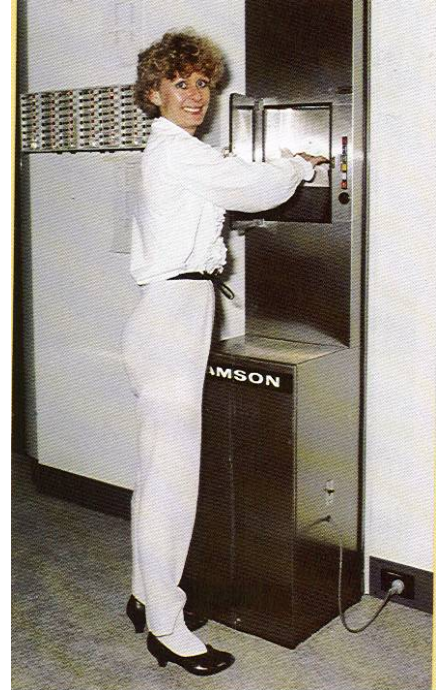

Reference: Chubb Security, Chatswood Medical Centre, Parliament House

Lamson Service Lifts

We can supply and install affordable dumb waiters for home or commercial applications. This is ideal for moving goods between floors. It is simple to use, quick to install, the lift car can be as small or large as required and above all is extremely affordable.

These systems are ideal for Restaurants, Hospital, Warehouses, Libraries, Bottle shops, Pubs & Clubs and of course for multi-storey houses.



Inside of a lift car with centre shelf



Trolley within lift car

Features include:

- Stainless steel or powder coated lift cars
- 200-400 kg payload
- Two to multi floor operation
- Call and send from each floor
- Arrival lights
- Speed 10 meters per minute
- Low voltage controls
- Override safety switches
- Slack rope cut out safety feature
- Shaft doors locked while car is in motion

References: Bondi Medical Centre, Residential (Sydney)

Lamson Transcar

Transcar is a so called Automatic Guided Vehicle (AGV). All vehicles share existing passageways and lifts with passenger traffic. The AGV follows a thin metallic strip laid on the floor surface or under the floor covering or can use laser guidance. Transport tasks are transmitted by means of wireless communication from the control computer to the vehicle. In most cases, loads will be handled automatically at loading or unloading stations which are determined and planned beforehand.

The system is specially suited for handling of trolleys.

In a hospital environment (meals, linen, refuse, magazine items, pharmaceuticals, medical records, sterile).

In industrial applications up to 400 kg (components, semi-conductors, small parts)

In offices to distribute mail trolleys.

Transcar has a very quick ROI and over 50 international hospitals use it.

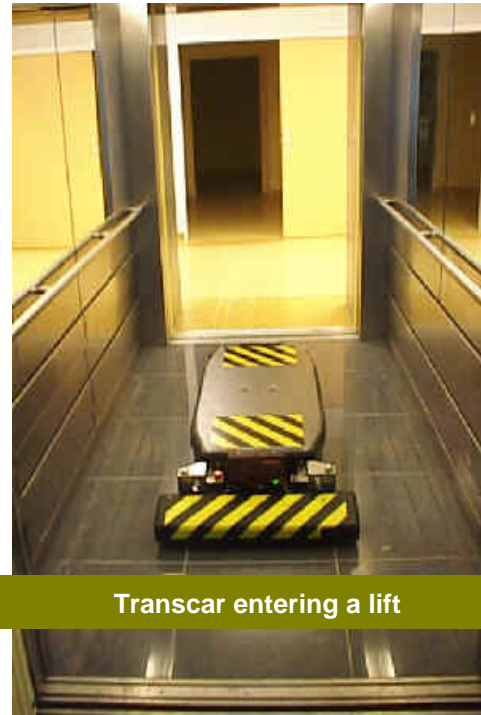

Transcar entering a lift



Transcar charging batteries in the basement of KKH

Transcar STC in a lift cabin

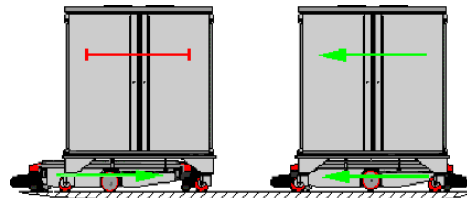

Coupling to a container is achieved by means of 2 pins that are automatically extended by the vehicle

Technical data, type STC

Payload (trolley weight): 300-400 kg, speed: max. 1 m/s

Bidirectional identical travel behaviour

Preferred direction applications depending on local safety requirements

Reference: National Library Australia, KK Childrens Hospital (Singapore), New Changi Hospital (Singapore)

Lamson Unicar

ADAL-System (Auto Drop Auto Load)

The goods to be transported are dropped into the Auto Load mailbox which has a preprogrammed destination assignment. A vehicle will be sent by the system control upon detecting items in Auto Load mailbox and the goods will be transferred automatically into this container. Upon arriving at the destination, the goods are dropped into designated receiving baskets.

The preprogrammed destination of each Auto Load box can be set by the user for each transport independently.

Unicar - Technical data:

Payload: 10 / 15 kg

Climbing ability: 90°

Speed: 0,6 m/s; special drive units up to 1,8 m/s

Bidirectional identical travel behavior



Unicar at receiving station delivering mail

All transport containers in the system can travel simultaneously, resulting in a high transport capacity. Using this system is as easy as using a telephone. Empty containers are provided at the station automatically dependent on the time of day and the clients operational requirements. The container is loaded and the destination code is keyed in at the station terminal. Off it goes...

Suitable transported material can also be loaded or discharged automatically. If required, the container covers can be electronically locked after loading

(confidential mail, medicines, etc.) by use of optionally fitted code locks. At the target station, the container can then only be opened by an authorised person typing the

A wide range of container versions and sizes are available, e.g. for documents, books, liquids, rolls of drawings, printing plates etc.

References: Governor Phillip Tower, St Vincents Hospital, Prince of Wales Hospital, Parliament House, Westmead Hospital, ADAL Department of Defence (Singapore)

Lamson EAS Systems (Electronic Article Surveillance)



ShopGuard® EAS systems is one of the leading manufacturers of Radio Frequency anti-shoplifting systems. This system is proven throughout the world to reduce shrinkage by utilizing the latest in electronic detection technology.

ShopGuard Gates are higher with three (3) styles (steel, security glass and wood) and they provide more accurate detection.

ShopGuard gates have audio and visual detection (operate with maximum detection).

Our systems provide a high level of operational reliability, making them less prone to false alarms.



We have an extensive range of security tags, labels and accessories.

ShopGuard supply the only security glass system in the world.

All ShopGuard gates have been tested.

All systems include quality antennas (detail to finish).



Radio Frequency (RF) – RF systems are the most commonly used throughout the world today, because of its wide range of accessories. ShopGuard's state-of-the-art RF (Radio Frequency) equipment operates on the basis of DSP (Digital Signal Processing). The systems are of self tuning capability, testing the environment periodically and adapting to any changes that might cause either false alarms or inhibitions of the system.

References: Cash Converters, Jaqui E, Priceline, Light and Sound, Apple Computers, Sports Power, . IGA Supermarkets

EAS Accessories

Accessories for the 8,2 MHz RF systems – soft and hard tags/labels



Suitable for all SHOPGUARD RF Systems. Available with the companies' logo at request. Offers all-round protection for a wide range of products.

Our accessories are extremely price competitive and compatible

Detectors

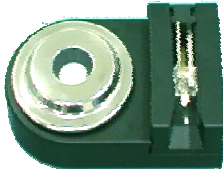

Table-top and built-in type for barcode scanners. No effect on credit cards and media products.



Magnetic detacher for tags

To open locking mechanism of soft and hard tags.

CD/DVD/Video Protectors

Protect DVD's, Videos and CD's with our plastic protectors



Loop Alarm System with Sensors

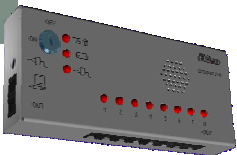

Loop alarm system protect your valuable display items

Lamson Trolleyguard



Trolley locks once taken over the signal cable or past the yellow line



Shopping trolley loss includes:

- Outright loss or theft
- Costs associated with retrieval of borrowed shopping trolleys
- Fines from municipal governments
- Extra inventory that must be maintained to compensate for missing shopping trolleys, i.e tractors, utes and trailers
- Excess maintenance expenses that result from abuse and damage to shopping trolleys that are removed from store property
- Claims against the retailer for property damage

With today's margins, replacing a single lost shopping trolley that originally cost \$150 represents the equivalent of \$7,500 in gross sales to a typical grocery company. Lamson estimates that the total problem costs retailers around the world in the range of \$800 million per year.



Because it is common for shoppers to "borrow" shopping trolleys to transport their purchases home or to a transit stop, retailers must contract for regular shopping trolley retrieval services. Retrieval contractors comb their neighborhoods several times per day or week, charging stores about \$1 per shopping trolley for retrieval. The total impact is typically thousands of dollars per site per year.

Lamson Trolleyguard

Many cities and countries have ordinances against the abandonment of shopping trolleys on city streets. The purpose of these ordinances is to prevent the deterioration of community appearance brought about by shopping trolleys that are taken off-site from retail establishments and left unattended.

In addition to costing retailers thousands, cities find that abandoned shopping trolleys constitute a nuisance, create potential hazards to the health and safety of the public, and interfere with pedestrian and vehicular traffic within the city. The accumulation of wrecked, dismantled and abandoned shopping trolleys on public or private property tends to create conditions that reduce property values, promoting blight and deterioration in the city.



Customer awareness signs are placed adjacent to yellow lines

REDUCE shopping trolley Loss and retrieval expenses by up to 98%

REDUCE shopping trolley cleaning and repair costs by up to 75%

INCREASE sales by ensuring clean shopping trolleys are available during peak shopping hours

IMPROVE community relations eliminates fines and impound fees by keeping your shopping trolleys out of the neighborhood

COMPLY with ordinances against shopping trolley abandonment and to provide retailers with a solution to their problem with shopping trolley loss



Wheels are easily reset by the push of a button

References: Franklins, Safeway, Big W, Harris Farm, IGA Supermarket

Lamson Tank

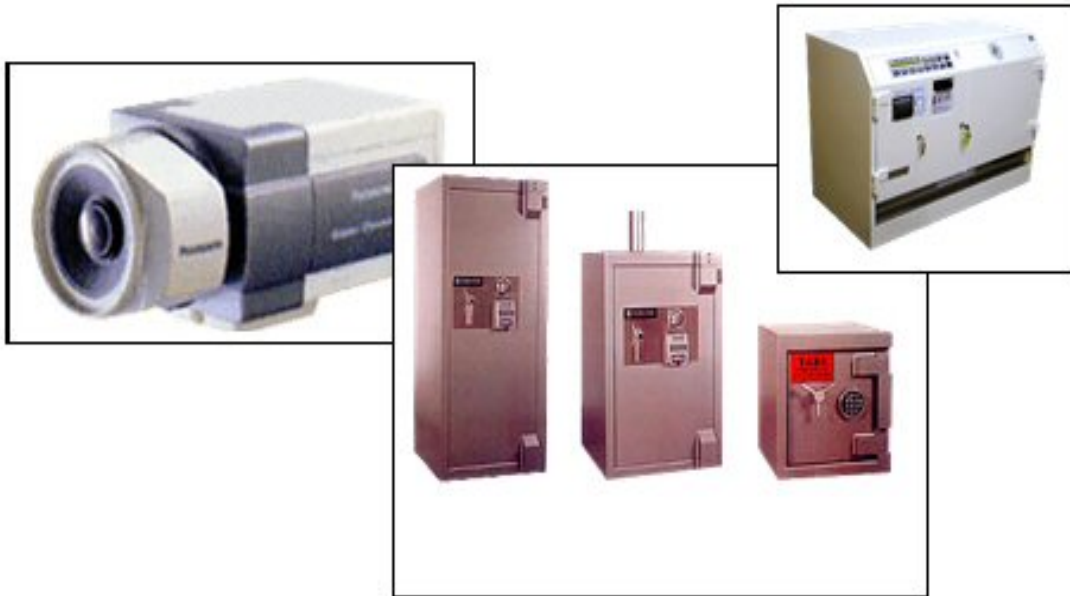

Lamson's sister company Tank Security operates out of Brunswick Melbourne and specialises in safes, alarms, CCTV, coin dispensing machines, Changemasters and more.

Clearance Safes:

This safe is the latest development in efficient cash management, combining all the features of the two key safe with an electronic bank note acceptor to verify drops.

Changemaster:

The changemaster is a rolled coin dispenser with note reader designed to enhance and facilitate cash management operations.

Safes:

Tank have a variety of safes to choose from. Our safes are an effective way to protect your cash without putting you or your staff a risk.

Alarms:

Advanced technology offers the best protection for your business premises and assets. The NX series offers up to 16 independent zones, which are easily expandable.

CCTV:

CCTV will allow you to observe the activities of your business premises inside and out.

Website: www.tanksecurity.com.au



Unit 7, 14-38 Bellona Avenue
 Regents Park, NSW 2143
 Tel: +61 (02) 9743 7322
 Fax: +61 (02) 9743 8569
 Toll Free: 1300 130 933
 Website: www.lamson.com.au



62, Dawson Street
 Brunswick, VIC 3056
 Tel: +61 (03) 9380 4555
 Fax: +61 (03) 9380 4003
 Website: www.tanksecurity.com.au

Lamson and Tank have joined forces to give you the 100% Australian owned one stop Loss Prevention and Engineering shop!

Loss Prevention

- Cash Tube System which include an audit trail of cash sends and parachute cash bags sent straight into a safe
- Shopguard electronic article surveillance gates for retailers
- Trolleyguard - an electronic trolley anti-theft system

Transport Systems

- Pneumatic Tube System suited for hospitals, industrial and commercial use
- Service Lifts - "Dumb Waiter"
- Transcar and Multicar Document Transport Systems

Physical Security

- Cash Management Safes
- Cash Trading Safes
- TACC (Time Access Cash Controller)
- Changemaster - rolled coin Dispenser
- Safe installation and Transportation
- Supermarket/Shop Entry Gates
- Fireproof Filing Cabinets
- Home Safes

Electronic Security

- Alarm Systems
- CCTV Systems
- Access Control Systems
- Alarm Monitoring
- Digital Video Recording
- Security Consultations

Technicians available on call service AUSTRALIA WIDE 24 hours, 7 days a week

Note: As many Lamson and Tank products are tailor made to our customers' needs, this list is by no means comprehensive

For additional assistance why don't you give us a call on the phone numbers listed

Customer Testimonials

Coles—Graeme Jordan, Building, Equipment and Maintenance

“We have installed a significant number of systems and are impressed with your smooth installation and commissioning procedures, particularly in trading stores. Our staff appreciate the additional security the system provides and it’s simplicity and reliability of operation”

Myer, Tea Tree Plaza—Kevin Buchan, Administration Manager

“The service has improved our efficiency both on the sales floor and in the cash office. The obvious procedure problems we encountered initially have been rectified. I would like to congratulate and thank your staff for the efficient manner the system has been installed and the follow up action taken to correct any problems that occurred.”

Goulburn Valley Health— Lindsay Dunstone, Manager

“Since installation in 1999, we have been very happy with both system performance and the level of support supplied by your company. Whilst we have high satisfaction with both the equipment and it’s installation, our highest praise is for your service staff, who have been prompt, courteous and provide quality education and communication.”

Bunnings—Mal Loudon, Senior Loss Prevention Manager

“Our business format is big box hardware retailing and we have found the Lamson Air Chute system to be of high quality with after sales service being a high priority. I have found by introducing the Lamson system the efficiency of our team members and the way in which we manage our cash handling has been streamlined and improved.”

St Vincents Hospital Melbourne—Tibor Novak, Project Manager

“I would like to express my satisfaction with the services provided during installation, testing, commissioning and training of the Pneumatic Chute system. Attitude, professionalism and technical skill of the installation team was outstanding and deserves recognition. Your company demonstrated a perfect example of how a good quality technical system can be implemented by employing high quality and well trained personnel.”

Jupiters Casino—Berni Keefe, Compliance Manager

“Since the implementation of CAST in August 2001, Conrad Jupiters has achieved not only a reduction on operating costs and improvement in the security funds, but our stated objective of providing seamless customer service. The use of this technology has resulted in an enhanced customer experience as well as providing an efficient alternative to a previously manual process.”

Quality Assurance

Through the late 80's and early 90's it became evident that the only way for an engineering and manufacturing company to survive is to have a quality assurance program in place. To this end, Lamson embarked on a quality assurance program in accordance with ISO9002 and for two years and a considerable resource and financial cost, Lamson have gained accreditation to ISO9002:1994.

We are audited through SGS

Our certificate number is 1115/98 dated 14 September 1998

Our last audit was in January 2005

For many practical reasons this is an important characteristic in the service and maintenance area. Staff regularly undergo product update and maintenance programs in head office Sydney.





Lamson

AUSTRALIA WIDE



Steve Cannon
 Manager
 National Retail Sales

Head Office

Lamson Concepts
 Unit 7, 14-38 Bellona Avenue
 Regents Park
 NSW 2143
 Australia

Tel: +61 (2) 9743 7322
 Fax: +61 (2) 9743 8569



Peter Symington
 Manager
 NSW Sales

Queensland	Victoria	South Australia	Western Australia
<p>Lamson Concepts 80-82 Dinwoodie Road Thornlands QLD 4164 Australia</p> <p>Tel: +61 (7) 3206 4322 Fax: +61 (7) 3206 0518</p>	<p>Lamson Concepts 14 Bastow Place Mulgrave VIC 3170 Australia</p> <p>Tel: +61 (3) 9560 5288 Fax: +61 (3) 9560 9932</p>	<p>Lamson Concepts 23 Naweena Road Regency Parl SA 5010 Australia</p> <p>Tel: +61 (8) 8243 2800 Fax: +61 (8) 8347 0402</p>	<p>Lamson Concepts Unit 6 13-15 Harvard Way Canning Vale WA 6155, Australia</p> <p>Tel: +61 (8) 9456 3266 Fax: +61 (8) 9456 0626</p>
 <p>David Higgins Manager Queensland Office</p>	 <p>Javid Khan Manager-Victoria Office / Export Manager</p>	 <p>Stephane Beraud Manager South Australia Office</p>	 <p>David Mears Manager Western Australia Office</p>

Website: www.lamson.com.au
 Email: info@lamson.com.au
 Toll Free: 1300 130 933



Lamson

WORLDWIDE AGENTS

We have agents based in many countries who are able to supply, install and maintain our system solutions. Some of our agents are as follows:

New Zealand

Mr John Doone
6 Botha Road
Penrose
Auckland
New Zealand

Tel: +64 9526 0121
Fax: +64 9526 0120
Website: www.lamson.co.nz

Canada

Mr Adam Cooper
Modus Group
4480 Chesswood Drive
Unit 1
Toronto, ON M3J 2B9
Canada

Tel: 416 322 5633
Fax: 416 322 0002
Email: adam@modusgroup.ca
Website: www.modusgroup.ca

United States of America

Mr Scott Begraft
Airtubes Inc.
93 Stickles Pond Road
Suite 7
Newton, NJ 07860
USA

Tel: 973 300 4267
Fax: 973 300 1932
Email: [sbegrft@airtubes.com](mailto:sbegraft@airtubes.com)
Website: www.airtubes.com

Egypt

Mr Mohammed Mansour
MK International Group
PO Box 2535
AL Saray Alexandria
Egypt

Tel: +20(3) 4241 308
Fax: +20(3) 4242 778
Email: mmansour@mk-intigroup.com
Website: www.team-works.net

South Korea

Mr N B Sung
CNT Holdings
5F Korad B/D, 1000-12
Dacchi-Dong, Kangnam-GU
Seoul, Korea

Tel:
Fax:
Email:
Website: www.cntholdings.com

Malaysia

Mr David Ong
Tripro Engineering Sdn Bhd
No. 8, Jalan TPK 2/6
Taman Perindustrian Kinrara
471 Puchong
Selangor Darul Ehsaan
Malaysia

Tel: +00 60(3) 8075 4993
Fax: +00 60(3) 8070 6380
Email: davidong@tripro.com.my

Singapore

Mr Peter Lim
PL Scientific Services
Blk C, 10 Penjuru Road
Singapore 609124

Tel: 65 6268 1613
Fax: 65 6457 1287
Email: business@piss.com.sg
Website: www.piss.com.sg

Indonesia

Mr Riansah Banda
Fajar Mekar Indah (FMI)
Jalan Jendral Gatot
Subroto KAV 53
Jakarta 12950

Tel: 62 21 526 0895
Fax: 62 21 525 0953
Email:

South Africa

Mr Arun Green
Mutual Safes International Pty Ltd
325 Zasm Street
Waltloo
0002 Pretoria
South Africa

Tel: 27 12 803 6051
Fax: 27 12 803 6094
Website: www.mutual.com.za

Thailand

Mr PRasong Santhongsuk
Aluco (Thailand) Co. Ltd
70/41 Moo 3, Sukhumvit 103 Rd
Pravet District
Bangkok 10250

Tel: +66 02 726 8155
Fax: +66 02 328 8577
Email: info@alucogroup.com
Website: www.alucogroup.com

Russia

Mr Alexander Kazarov
IRA-PROM Industrial Group
28-2 Rublevskoe Shossee
Moscow 121 609
Russia

Tel: +7 095 4155001
Fax: +7 095 4155001
Email: info@torgkompiekt.ru

