



## Continuous Gas Analysis

Gas Analyzer for Determination of Total Hydrocarbon Content

FIDAMAT 6

Operating Instructions



## Continuous Gas Analysis

### Gas analyzer for determination of total hydrocarbon content FIDAMAT 6

#### Operating Instructions

<u>Introduction</u>	<b>1</b>
<u>Safety instructions</u>	<b>2</b>
<u>Description</u>	<b>3</b>
<u>Installing</u>	<b>4</b>
<u>Connecting</u>	<b>5</b>
<u>Commissioning</u>	<b>6</b>
<u>Operation</u>	<b>7</b>
<u>Functions</u>	<b>8</b>
<u>Service and maintenance</u>	<b>9</b>
<u>Spare parts and accessories</u>	<b>10</b>
<u>Technical specifications</u>	<b>11</b>
<u>Dimensional drawings</u>	<b>12</b>
<u>Appendix</u>	<b>A</b>
<u>List of abbreviations</u>	<b>B</b>

7MB2421

## Legal information

### Warning notice system

This manual contains notices you have to observe in order to ensure your personal safety, as well as to prevent damage to property. The notices referring to your personal safety are highlighted in the manual by a safety alert symbol, notices referring only to property damage have no safety alert symbol. These notices shown below are graded according to the degree of danger.

<b>⚠ DANGER</b>
indicates that death or severe personal injury <b>will</b> result if proper precautions are not taken.
<b>⚠ WARNING</b>
indicates that death or severe personal injury <b>may</b> result if proper precautions are not taken.
<b>⚠ CAUTION</b>
indicates that minor personal injury can result if proper precautions are not taken.
<b>NOTICE</b>
indicates that property damage can result if proper precautions are not taken.

If more than one degree of danger is present, the warning notice representing the highest degree of danger will be used. A notice warning of injury to persons with a safety alert symbol may also include a warning relating to property damage.

### Qualified Personnel

The product/system described in this documentation may be operated only by **personnel qualified** for the specific task in accordance with the relevant documentation, in particular its warning notices and safety instructions. Qualified personnel are those who, based on their training and experience, are capable of identifying risks and avoiding potential hazards when working with these products/systems.

### Proper use of Siemens products

Note the following:

<b>⚠ WARNING</b>
Siemens products may only be used for the applications described in the catalog and in the relevant technical documentation. If products and components from other manufacturers are used, these must be recommended or approved by Siemens. Proper transport, storage, installation, assembly, commissioning, operation and maintenance are required to ensure that the products operate safely and without any problems. The permissible ambient conditions must be complied with. The information in the relevant documentation must be observed.

### Trademarks

All names identified by ® are registered trademarks of Siemens AG. The remaining trademarks in this publication may be trademarks whose use by third parties for their own purposes could violate the rights of the owner.

### Disclaimer of Liability

We have reviewed the contents of this publication to ensure consistency with the hardware and software described. Since variance cannot be precluded entirely, we cannot guarantee full consistency. However, the information in this publication is reviewed regularly and any necessary corrections are included in subsequent editions.

# Table of contents

<b>1</b>	<b>Introduction</b> .....	<b>9</b>
1.1	Device versions.....	9
1.2	General information .....	10
1.3	Proper use .....	10
1.4	Qualified personnel .....	11
1.5	Warranty conditions .....	11
1.6	Delivery information .....	11
1.7	Date of manufacture .....	12
1.8	Standards and regulations .....	13
1.9	Information on recycling.....	13
<b>2</b>	<b>Safety instructions</b> .....	<b>15</b>
2.1	Requirements for safe use.....	15
2.2	Basic safety instructions .....	15
<b>3</b>	<b>Description</b> .....	<b>17</b>
3.1	Field of application and features.....	17
3.1.1	Field of application .....	17
3.1.1.1	Field of application of the FIDAMAT 6-E .....	17
3.1.1.2	Field of application of the FIDAMAT 6-G .....	18
3.1.2	Features and functions .....	19
3.1.3	Certified operation for emission monitoring according to EN 15267-3.....	20
3.2	Design .....	21
3.2.1	Design of the device .....	21
3.2.2	Design of the enclosure .....	22
3.3	Control panel and communication .....	23
3.4	Method of operation .....	26
3.5	Gas flow .....	28
3.5.1	Gas flow of the FIDAMAT 6-E .....	28
3.5.2	Gas flow of the FIDAMAT 6-G .....	29
3.6	Communication .....	30
3.6.1	General information .....	30
3.6.2	ELAN interface.....	30
3.6.3	SIPROM GA.....	32
3.6.3.1	SIPROM GA functions .....	32
3.6.3.2	Upgrading options.....	33
3.6.4	PROFIBUS DP/PA.....	34

<b>4</b>	<b>Installing .....</b>	<b>37</b>
4.1	Safety information for installation .....	37
4.2	Mounting instructions .....	38
4.3	Cabinet installation.....	39
4.4	Ventilation of the device .....	39
<b>5</b>	<b>Connecting .....</b>	<b>41</b>
5.1	Safety information for connecting .....	41
5.2	Gas and electrical connections on the device .....	42
5.3	Gas connections .....	44
5.3.1	Connecting gas .....	45
5.3.2	Sample gas disposal.....	45
5.4	Electrical connection .....	46
5.4.1	Notes for electrical connections .....	46
5.4.2	Connecting signal cables .....	47
5.4.3	Connecting the power supply.....	48
5.4.4	Circuit diagrams (pin assignment) .....	49
5.4.4.1	Motherboard pin assignments.....	49
5.4.4.2	Plug connector assignment of the optional board and PROFIBUS .....	50
5.4.4.3	ELAN interface cable .....	51
<b>6</b>	<b>Commissioning .....</b>	<b>53</b>
6.1	Safety information for commissioning .....	53
6.2	Preparation for commissioning .....	55
6.2.1	General information for commissioning .....	55
6.2.2	Gas preparation .....	55
6.2.2.1	Supply gas .....	55
6.2.2.2	Sample gas .....	56
6.2.3	Checking for leaks .....	56
6.3	Commissioning and operation .....	58
6.3.1	Warm-up phase.....	58
6.3.2	Operating states.....	60
6.3.2.1	Operating state of the FIDAMAT 6-E .....	60
6.3.2.2	Operating state of the FIDAMAT 6-G.....	61
6.3.3	State change due to fault / maintenance request .....	62
6.3.4	Measuring ranges .....	63
<b>7</b>	<b>Operation.....</b>	<b>65</b>
7.1	User interface and operating modes.....	65
7.2	Measured value display .....	69
7.3	Entering a submenu .....	70
7.4	Jump back to coded/decoded display mode.....	71
7.5	Fast function selection .....	71

7.6	Calibration.....	72
7.6.1	General information on calibration.....	72
7.6.2	Calibration examples.....	72
<b>8</b>	<b>Functions.....</b>	<b>75</b>
8.1	Overview of operating functions.....	75
8.2	Analyzer status.....	76
8.2.1	Analyzer status submenu.....	76
8.2.2	Analyzer configuration (function 1).....	77
8.2.3	Diagnostic values (function 2).....	77
8.2.4	Logbook (function 3).....	78
8.2.5	Display measuring ranges (function 4).....	78
8.3	Calibration.....	79
8.3.1	Calibration submenu.....	79
8.3.2	Zero calibration (function 20).....	80
8.3.3	Span calibration (function 21).....	80
8.3.4	Setting the setpoints (function 22).....	82
8.3.5	Total / single calibration (function 23).....	83
8.3.6	AUTOCAL (function 24).....	83
8.3.7	Drift values (function 25).....	89
8.4	Measuring ranges.....	90
8.4.1	Measuring ranges submenu.....	90
8.4.2	Select measuring ranges (function 40).....	90
8.4.3	Define measuring ranges (function 41).....	93
8.5	Parameters.....	94
8.5.1	Parameters submenu.....	94
8.5.2	Electric time constants (function 50).....	94
8.5.3	Limits (function 51).....	95
8.5.4	On/off functions (function 52).....	96
8.5.5	Status messages (function 53).....	97
8.5.6	Graphical representation of measured values (function 54).....	99
8.5.7	Measured value display (function 55).....	100
8.5.8	LCD contrast (function 56).....	101
8.5.9	Ignite flame (function 57).....	101
8.5.10	Date/time (function 58).....	102
8.5.11	Measuring point switching (function 59).....	103
8.5.12	Logbook settings (function 60).....	103
8.5.13	Internal valves (function 61).....	104
8.5.14	Set external pressure (function 62).....	104
8.6	Configuration.....	105
8.6.1	Configuration submenu.....	105
8.6.2	Analog output (function 70).....	106
8.6.3	Relay outputs (function 71).....	107
8.6.4	Binary inputs (function 72).....	109
8.6.5	ELAN configuration (function 73).....	115
8.6.6	Reset (function 74).....	116
8.6.7	Save / load data (function 75).....	116
8.6.8	Suppression of short-term noise signals (function 76).....	118
8.6.9	Analog output memory (function 77).....	119
8.6.10	Calibration tolerances (function 78).....	119

8.6.11	Change codes (function 79).....	121
8.6.12	Device test (function 80).....	121
8.6.13	Language selection (function 81).....	122
8.6.14	Correction of cross-interference (function 83).....	123
8.6.15	Switch valves (function 85).....	125
8.6.16	Linear temperature compensation (function 86).....	126
8.6.17	Error on/off (function 87).....	127
8.6.18	PROFIBUS configuration (function 90).....	127
8.6.19	Start-up state (function 91).....	128
8.6.20	Pressure values (function 92).....	130
8.6.21	Dimensions (function 93).....	131
8.6.22	Factory settings (function 99).....	131
<b>9</b>	<b>Service and maintenance.....</b>	<b>133</b>
9.1	General safety information for service and maintenance.....	133
9.2	General information on maintenance.....	135
9.3	Maintaining the device.....	135
9.4	Cleaning the device.....	136
9.5	Replacing the motherboard and option board.....	136
9.6	Replacing line fuses.....	137
9.7	Maintenance request and fault message.....	137
9.8	List of maintenance requests.....	139
9.9	List of faults.....	140
9.10	Other faults.....	142
<b>10</b>	<b>Spare parts and accessories.....</b>	<b>145</b>
10.1	Ordering information.....	145
10.2	Spare parts list.....	146
10.3	Gas flow diagram with spare parts.....	149
10.3.1	Gas flow diagram of FIDAMAT 6-E.....	149
10.3.2	Gas flow diagram of FIDAMAT 6-G.....	152
10.4	Device views with spare part numbers.....	155
10.4.1	Device views of FIDAMAT 6-E.....	155
10.4.2	Device views of FIDAMAT 6-G.....	161
<b>11</b>	<b>Technical specifications.....</b>	<b>167</b>
11.1	General technical data of the FIDAMAT 6 gas analyzers.....	167
11.2	Technical specifications of the FIDAMAT 6-E.....	169
11.3	Technical data of the FIDAMAT 6-G.....	170
<b>12</b>	<b>Dimensional drawings.....</b>	<b>173</b>



<b>A</b>	<b>Appendix.....</b>	<b>175</b>
	A.1 Technical support.....	175
	A.2 Return procedure.....	176
	A.3 ESD guidelines.....	176
	A.4 Overview of operating functions.....	178
	A.5 Wiring diagrams.....	180
	A.5.1 Motherboard pin assignments.....	180
	A.5.2 Plug connector assignment of the optional board and PROFIBUS.....	181
	A.5.3 Gas flow of the FIDAMAT 6-E.....	182
	A.5.4 Gas flow of the FIDAMAT 6-G.....	183
<b>B</b>	<b>List of abbreviations.....</b>	<b>185</b>
	B.1 List of abbreviations.....	185
	<b>Glossary.....</b>	<b>189</b>
	<b>Index.....</b>	<b>197</b>



# Introduction

Before beginning work with this device, please read this manual! It contains important information and data that must be observed to ensure proper functioning of the device and to save on service costs. The manual will help you to operate the device more easily and efficiently, allowing you to achieve reliable results.

## 1.1 Device versions

The FIDAMAT 6 is designed for quantitative determination of hydrocarbons and is available in various configurations.

This manual describes the following device versions:

Device version	Description	Article number (MLFB)
FIDAMAT 6-E	For sample gas with atmospheric pressure, with heated pump and combustion air connection	7MB2421-xDA1x-xxAx
FIDAMAT 6-G	For sample gas with overpressure, for ultra-pure gas measurement, without pump	7MB2421-xBA1x-xxAx

---

### Note

#### Differences between device versions

The two device versions FIDAMAT 6-E and FIDAMAT 6-G are described individually if differences exist. The name of the device version involved is indicated when describing differences.

However, where features or procedures are described that apply to all versions of the FIDAMAT 6 series, the standard name FIDAMAT 6 will be used or omitted altogether.

---

## 1.2 General information

This device left the factory in a safe and proper condition and has been tested. In order to maintain this condition and to ensure safe operation, it should only be used in the manner described by the manufacturer. Furthermore, proper transportation, storage, installation, operation and maintenance of the device are vital for ensuring correct and safe operation.

This manual contains the information required for the intended use of the described product.

It is addressed to technically qualified personnel who are specially trained or who have the relevant knowledge of automation technology (measuring and control systems).

Knowledge and technically correct implementation of the safety notes and warnings contained in this manual are required for safe installation and commissioning, as well as for safety during the operation and maintenance of the described product. Only qualified personnel have the required professional knowledge for correctly interpreting the generally valid safety notes and warnings in this manual in each specific case and to act accordingly.

This manual is an inherent part of the scope of delivery, despite the fact that it can be ordered separately for logistic reasons.

Due to the variety of technical details, it is not possible to consider every single detail for all versions of the described product and for every conceivable case in the set-up, operation, maintenance and use in systems. For further information, or in the case of problems which are not covered in enough detail in this document, please request the required information from your local or responsible Siemens regional office.

---

### Note

In particular, before using the device for new research and development applications, we recommend that you first contact us to discuss the application in question.

---

This manual provides you with information on commissioning, installing, operating, and maintaining the device.

Pay particular attention to all special information and warnings. Information of this type is set apart from the rest of the text and is marked with the corresponding pictograms. This information provides you with useful tips and helps avoid operating errors.

## 1.3 Proper use

Proper use within the context of this manual means that the product may be used only for the applications described in the catalog or the technical description, and only in combination with the equipment, components and devices of other manufacturers recommended or approved by Siemens.

## 1.4 Qualified personnel

Persons who install, connect, commission, operate, service, maintain and disassemble the device must have the following specific qualifications:

- They are authorized and trained or instructed in operating and maintaining devices and systems according to the safety regulations for electrical circuits, high pressures and corrosive as well as hazardous media.
- They are trained or instructed in the maintenance and use of appropriate safety equipment according to the pertinent safety regulations.

## 1.5 Warranty conditions

We expressly point out that the product quality is exclusively and conclusively described in the sales contract. The content of this product documentation is neither a part of a previous or existing agreement, promise or legal relationship, nor is it intended to modify these. All obligations on the part of Siemens AG are contained in the respective sales contract, which also contains the complete and solely applicable liability provisions. The provisions defined in the sales contract for the responsibility for defects are neither extended nor limited by the remarks in this document.

## 1.6 Delivery information

The respective scope of delivery is listed on the shipping documents in accordance with the valid sales contract. These are enclosed with the delivery.

When opening the packaging, please observe the corresponding information on the packaging material. Check the delivery for completeness and undamaged condition. In particular, the Order No. on the labels, if present, must be compared with the ordering data.

# 1.7 Date of manufacture

## Year of manufacture

The date of manufacture is included as coded information in the serial number (see rating plate). Details on the coding can be found in the following table.

Production year	Code <sup>1)</sup>	Month	Code <sup>1)</sup>
1950, 1970, 1990, 2010	A	January	1
1951, 1971, 1991, 2011	B	February	2
1952, 1972, 1992, 2012	C	March	3
1953, 1973, 1993, 2013	D	April	4
1954, 1974, 1994, 2014	E	May	5
1955, 1975, 1995, 2015	F	June	6
1956, 1976, 1996, 2016	H	July	7
1957, 1977, 1997, 2017	J	August	8
1958, 1978, 1998, 2018	K	September	9
1959, 1979, 1999, 2019	L	October	O
1960, 1980, 2000, 2020	M	November	N
1961, 1981, 2001, 2021	N	December	D
1962, 1982, 2002, 2022	P		
1963, 1983, 2003, 2023	R		
1964, 1984, 2004, 2024	S		
1965, 1985, 2005, 2025	T		
1966, 1986, 2006, 2026	U		
1967, 1987, 2007, 2027	V		
1968, 1988, 2008, 2028	W		
1969, 1989, 2009, 2029	X		

Example:

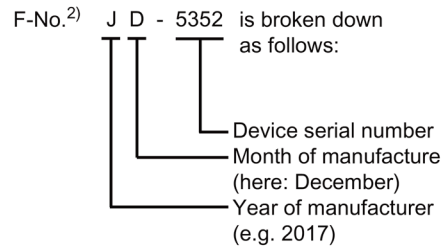

<sup>1)</sup> In conformance with DIN EN 60062

<sup>2)</sup> The identifier of the manufacturing location (e.g. N1) is added as a prefix to the actual serial number

## 1.8 Standards and regulations

As far as possible, the harmonized European standards were the basis for the specification and production of this device. If no harmonized European standards have been applied, the standards and regulations for the Federal Republic of Germany are valid.

When this product is used beyond the scope of these standards and regulations, the valid standards and regulations of the country of the operating company apply.

## 1.9 Information on recycling



This product is from an environmentally-friendly manufacturer and complies with the directive 2012/19/EU on Waste Electrical and Electronic Equipment (WEEE).

This product may contain substances that are potentially harmful to the environment if disposed of improperly (landfills, incineration plants). It must therefore not be disposed of in this way.

Therefore, please be environmentally conscious:

- Ensure that this product is recycled at the end of its life cycle through the relevant local facilities!
- Observe the relevant regulations in your country.







## Safety instructions

### 2.1 Requirements for safe use

In terms of safety, this device left the factory in perfect condition. In order to maintain this status and to ensure safe operation of the device, observe these operating instructions and all the information relevant to safety.

Observe the information and symbols on the device. Do not remove any information or symbols from the device. Always keep the information and symbols in a completely legible state and renew it, if necessary.

Symbol	Description
	Consult operating instructions
	Hot surface
	Dangerous electrical voltage

### 2.2 Basic safety instructions

 <b>WARNING</b>
<p><b>Introduction of combustible gases</b></p> <p>Danger of explosion</p> <p>The device is <b>not</b> designed for measurement of ignitable gas mixtures.</p> <ul style="list-style-type: none"> <li>• If the device is used to measure flammable gases that can combine with air or oxygen to form an ignitable gas mixture, take special explosion protection measures!</li> </ul>

 **WARNING**

**Device modifications**

Danger to personnel, system and the environment can result from modifications and repairs to the device.

- Only carry out modifications or repairs that are described in the operating instructions for the device.
- Failure to observe this requirement cancels the manufacturer's warranty and the product approvals.

## Description

### 3.1 Field of application and features

#### 3.1.1 Field of application

The FIDAMAT 6 gas analyzer is used for quantitative determination of hydrocarbons.

The measuring principle is based on flame ionization detection (FID). When all requirements for purity of the zero gas, calibration gas and operating gases are met, the detection limit is approx. 30 ppb. During the combustion of hydrocarbons in a hydrogen flame, ions are formed that are in turn converted into a current flow by the application of an electric field. The resulting amperage is a measure of the number of carbon atoms.

---

#### Note

The FIDAMAT 6 is designed for continuous operation. Frequent switching on and off (e.g. daily) can negatively affect the service life of the ignition device and pilot light.

---

#### 3.1.1.1 Field of application of the FIDAMAT 6-E

##### Measuring environment

The FIDAMAT 6-E is suitable for measurements of hydrocarbons:

- In the presence of up to 100% water vapor
- With high-boiling components (up to 200 °C)
- In the presence of corrosive gases (with preliminary filter)
- In ultra-pure gas applications

##### Properties of the device

The FIDAMAT 6-E has the following properties:

- Extremely low cross-sensitivity to interfering gases
- Low consumption of combustion air

The device is also equipped with warning and fault messages, e.g. in case of the following:

- Failure of combustion gas
- Extinguishing of the flame
- Malfunctions of pump and filter

### 3.1 Field of application and features

#### Fields of application

The FIDAMAT 6-E gas analyzer is characterized by a wide range of possible applications and is used in the following fields:

- Environmental protection
- Wastewater treatment in combination with a stripping device for verification of hydrocarbon content of liquids
- Occupational exposure limit monitoring in workplace air
- Quality monitoring
- Process exhaust monitoring
- Ultra-pure gas measurement in media such as O<sub>2</sub>, CO<sub>2</sub>, inert gases and cold sample gases
- Measurement of corrosive and condensing gases
- Process optimization
- Emission monitoring

#### Further applications

- Chemical plants
- Gas manufacturers (ultra-pure gas monitoring)
- Cement industry (measurement of emissions)
- Paint shops and dry cleaners
- Refineries (tank farms, wastewater)
- Drying systems
- Solvent recovery systems
- Pharmaceutical industry
- Automotive industry (engine development, vehicle powertrain development and certification)
- Research and development
- Special applications, e.g. with a measuring range of 0 to 100% (on request)

#### 3.1.1.2 Field of application of the FIDAMAT 6-G

#### Measuring environment

The FIDAMAT 6-G is suitable for measurements of hydrocarbons:

- In pure and ultra-pure gases
- In **non**-corrosive and non-condensing gas mixtures

### Properties of the device

The FIDAMAT 6-G has the following properties:

- Extremely low cross-sensitivity to interfering gases
- Low consumption of combustion air
- Little influence by oxygen

The device is also equipped with warning and fault messages, e.g. in case of the following:

- Failure of combustion gas
- Extinguishing of the flame

### Fields of application

The FIDAMAT 6-G gas analyzer can be used in the following fields:

- Quality monitoring
- Ultra-pure gas measurement in media such as O<sub>2</sub>, CO<sub>2</sub>, noble gases and cold sample gases, with the exception of helium and hydrogen
- Process optimization
- Gas producers (quality control for ultra-pure gases)
- Research and development

## 3.1.2 Features and functions

### Features

The devices are characterized by the following features:

- Galvanically isolated measured value output 0/2/4 to 20 mA (also inverted)
- Short response time
- Low long-term drift
- Easy operation with the help of a numerical membrane keyboard and operator prompting
- Operation based on the NAMUR recommendation
- Digital display of gas concentration, sample gas/combustion air pressure and combustion gas pressure
- Menu and interface are compatible with the other devices of series 6 (CALOMAT 6, OXYMAT 6, ULTRAMAT 6, etc.).
- Very small spans
- Selectable time constants (static/dynamic noise suppression), i.e. the response time of the device can be adapted to the respective measuring task.
- Response factors comply with EN 12619

### 3.1 Field of application and features

- External pressure sensor can be connected for correction of process gas pressure fluctuations
- Easy device replacement since electrical connections of the device can be easily disconnected
- No clogging in the sample gas capillary tube thanks to the use of a quartz capillary tube
- Wear-free, corrosion-proof filter
- Required combustion gas: hydrogen (H<sub>2</sub>)
- Communication via RS485 in the basic unit

### Functions

The devices have the following functions:

- Menu-driven operation for parameterization, test functions, calibration
- Four measuring ranges can be user-configured, including with suppressed zero point, all measuring ranges are linear
- Automatic or manual measuring range switchover can be selected; remote switchover also possible
- Measuring point switchover for up to 6 measuring points
- Three operation levels with their own authorization code to prevent accidental and unauthorized operator interventions.
- Automatic measuring range calibration can be configured
- Measured values can be saved while calibrating
- Flushing function in the event of analyzer or power supply failure (avoids build-up of toxic and corrosive substances in the device)
- PROFIBUS (DP/PA) interface (optional)
- AUTOCAL (optional)

#### 3.1.3 Certified operation for emission monitoring according to EN 15267-3

Some device versions are designed and certified by the TÜV for measurement of oil, coal, gas and waste fuels in flue gases according to 13th BImSchV/17th BImSchV and TA Luft. Furthermore, these devices meet the requirements of ISO 14965 and QAL 1 according to EN 14181.

#### Application according to 13th, 30th and 31st BImSchV and TA Luft

This function pertains only to device version 7MB2421-xDA1x-1AAx-Y27.

For certified operation, a compensation of the influence of interference gas caused by oxygen is required. For this purpose, the analyzer must be supplied with the current oxygen concentration value of the sample gas. This is done by an external measuring instrument, which must also meet the requirements of EN 15267-3 (e.g. ULTRAMAT 23 or OXYMAT 6).

The FIDAMAT 6E –Y27 is preconfigured for this and expects an analog signal of 4 ... 20 mA corresponding to 0 ... 21 vol% O<sub>2</sub> at analog input AI2.

### Additional application according to 17th BImSchV

This function pertains only to device version 7MB2421-xDA1x-1AAx–Y37 for the CEM Cert system set "Fidamat 6 Measuring System II".

The device has an internal oxygen compensation. No external oxygen connection is permitted for this application. Oxygen-free gases are to be used for calibration of zero gas (function 20) and calibration gas (function 21).

## 3.2 Design

### 3.2.1 Design of the device

#### Overview

The FIDAMAT 6 is made up of two main assemblies:

- Electronics
- Analyzer part

The FIDAMAT 6 is designed in such a way that the parts contained in it are easy to access for service. Access from both the top (for maintenance of individual components) and the rear is possible. The gas connections and the electrical connections are located on the back of the device.

The sample gas pump of the FIDAMAT 6-E is easily accessible from the top.

#### Electronics

The electronics consists of:

- Control board with display  
The control board is integrated into the front panel
- Motherboard
- Adapter board  
The adapter board contains the preamplifier for the measured value acquisition and the control unit.
- Option boards: PROFIBUS (DP/PA), AUTOCAL

### Analyzer part

The analyzer part of the FIDAMAT 6-E consists of an oven in which the following components are installed:

- Flame ionization detector (FID)
- Various restrictors
- Heated sample gas filter (FIDAMAT 6-E only)

Outside the oven are:

- 2 pressure regulators
- 2 pressure sensors
- Solenoid valves
- Bulkhead unions 6 mm or 1/4"
- Heated pump (FIDAMAT 6-E only)

### Materials used

Table 3- 1 Materials used

Device component	Material
<b>Gas path</b>	
Piping	Stainless steel 1.4571 / 1.4404
Gas inlet	Stainless steel 1.4571 / 1.4404
Gaskets	Graphite
Sample gas restrictor	Stainless steel 1.4404
Auxiliary gas restrictors	Stainless steel 1.4571 / 1.4404
Pump diaphragm (FIDAMAT 6-E only)	PTFE
Pump head (FIDAMAT 6-E only)	Stainless steel 1.4571 / 1.4404
<b>Flame ionization detector (FID)</b>	
Nozzle	Quartz
FID housing	Stainless steel 1.4571 / 1.4404

### 3.2.2 Design of the enclosure

- 19" rack unit with 4 HU
  - For installation in a hinged frame
  - In cabinets, with telescopic or support rails
- Front panel can be swiveled downward for service purposes (for example, for connecting a notebook via RS 485)
- Gas connections for sample gas inlet (sample) and gas outlet (exhaust), as well as combustion gas and combustion air, pipe union for pipes with outer diameter of 6 mm or 1/4"



## 3.3 Control panel and communication

### Display and control panel

The display and control panel is characterized by the following features:

- Large LCD for simultaneous display of, for example:
  - Measured value (digital and analog displays)
  - Measuring ranges
  - Status line
- Contrast of the LCD can be adjusted
- Continuous LED backlighting
- 5-digit measured-value display (decimal point counts as a digit)
- Washable membrane keyboard/front panel
- Menu-driven operation for parameter assignment, test functions and calibration
- User help in plain text
- Graphical display of the concentration curve; time intervals can be configured
- Bilingual operating software:
  - German/English
  - English/Spanish
  - French/English
  - Spanish/English
  - Italian/English

Membrane keyboard and display

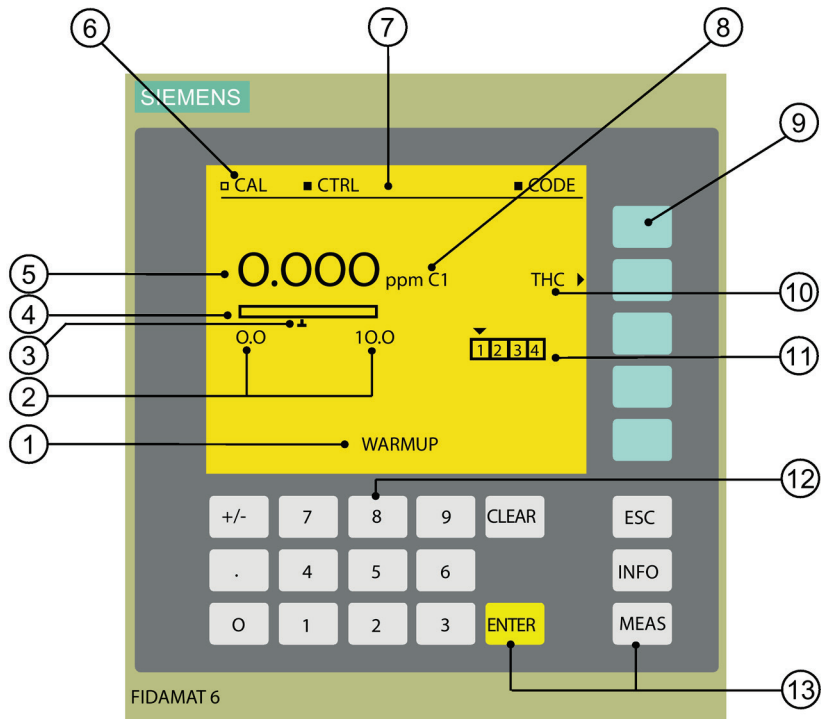

- ① Bottom line (display of current operating state)
- ② Measuring range with start-of-scale value and full-scale value
- ③ Limit marking
- ④ Analog measured value display (bar display)
- ⑤ Measured value
- ⑥ Status message
- ⑦ Status line
- ⑧ Display of unit of measurement
- ⑨ Buttons with varying function (soft keys)
- ⑩ Display of measured component
- ⑪ Display of activated measuring ranges with marking of the current range
- ⑫ Numeric keypad
- ⑬ Function keypad

Figure 3-1 Measured value display and operator panel

Inputs and outputs

The inputs and outputs have the following properties and functions:

- Two analog inputs can be configured
- One analog output 0/2/4 – 20 mA
- Six user-configurable binary inputs, for example, for:
  - Autorange
  - Processing external signals from the sample preparation

- Six user-configurable relay outputs, for example, for:
  - Fault
  - Maintenance request
  - Limit alarm
  - External solenoid valves
- Can be extended by eight binary inputs and eight relay outputs for automatic calibration with a maximum of four calibration gases

## Communication

By default, the communication between several analyzers takes place via the integrated RS485 interface for the internal bus (ELAN). The connector is on the back of the device.

The following products are optionally available:

- Interface converter for conversion of the RS485 serial interface
  - to RS232 (ELAN networking)
  - to TCP/IP-Ethernet (ELAN networking)
  - to USB (ELAN networking)
- Plug-in card for PROFIBUS DP/PA for connection to networks
- Networking with the SIPROM GA software as a service and maintenance tool (for ELAN)

### 3.4 Method of operation

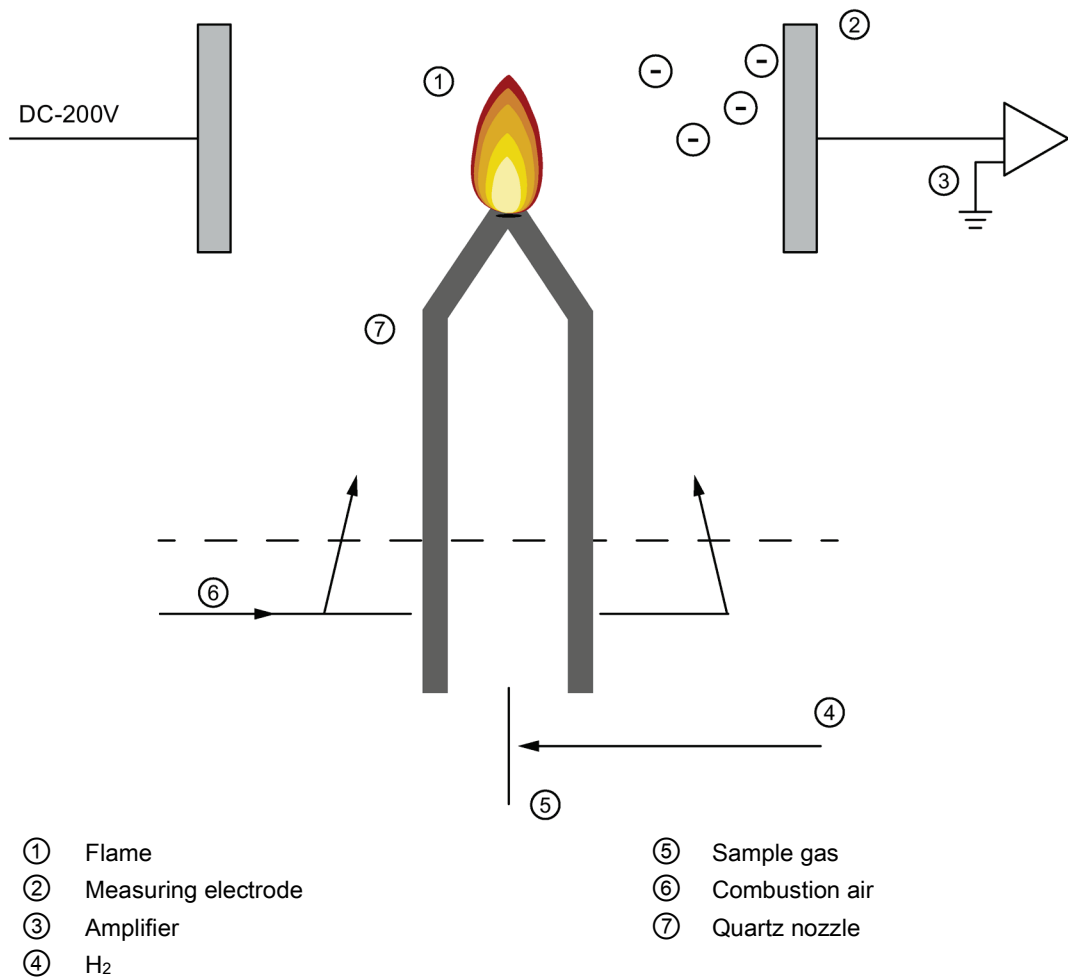

Figure 3-2 Method of operation of flame ionization detector

---

#### Note

##### Differences in the method of operation for the device versions

Unless stated otherwise, the description relates to both device versions of the FIDAMAT 6.

---

The measuring principle is based on flame ionization detection (FID) with a detection limit of approximately 0.1 ppm. During the combustion of hydrocarbons in a hydrogen flame, ions are formed that are in turn converted into a current flow by the application of an electric field. The resulting amperage is a measure of the number of carbon atoms.

The FIDAMAT 6 measures specific to the substance class, not component-specific. It measures the total of all organically bound carbons in a sample gas, however with different weighting of the hydrocarbon molecules.

In a first approximation, the display is proportional to the number of C atoms in the respective molecule. However, there are deviations in practice. The display deviation for the specific molecule is expressed by the response factor.

**FIDAMAT 6-E:** The sample gas is drawn into the FIDAMAT 6-E by the integrated diaphragm pump and is carried under overpressure over a heated line and an additional filter. It arrives at the flame ionization detector via a clog-proof restrictor.

**FIDAMAT 6-G:** The sample gas is supplied to the flame ionization detector in the FIDAMAT 6-G under overpressure via a clog-proof restrictor.

The hydrocarbons contained in the sample gas are combusted in an oxyhydrogen gas flame in the flame ionization detector. During combustion, the organically bound hydrocarbon part is ionized. The released ions are converted into an ion current by the polarization voltage existing between two electrodes and measured using a highly sensitive amplifier.

The measured current is proportional to the number of organically bound C atoms of the hydrocarbons in the sample gas.

A pressure regulator keeps the combustion gas pressure constant. A constant sample gas pressure is ensured by the coordinated system, which is made up of capillaries and a pressure regulator for combustion air and, in the case of the FIDAMAT 6-E, a pump.

After switching on the analyzer, the flame will be ignited as soon as a temperature of 155 °C is reached in the FID. You can use function 2 "Diagnostic values" to retrieve the current temperature of the FID under "Flame".

**FIDAMAT 6-E:** When the flame has reached a temperature of 220 °C (430 °F), the pump startup begins automatically.

The FIDAMAT 6 transmits various messages outward in the form of floating contacts:

- Maintenance request:
  - Fan failure (preliminary warning for measuring accuracy)
  - Sample gas flow (filter/pump) for FIDAMAT 6-E only

After a maintenance request, the device continues measuring normally. The measured value is not influenced.

- Fault:
  - Hydrogen, combustion air and sample gas pressure, temperature, physical part (for FIDAMAT 6-E with pump), faults in the electronics (temperature).

If the measured value is influenced, the device may switch to another operating state (combustion gas valve is closed).

---

**Note**

The sample gases fed to the device must be free of dust and condensation. To prevent condensation, it is necessary in most applications to use a gas preparation system adapted to the measuring task.

---

### 3.5 Gas flow

#### 3.5.1 Gas flow of the FIDAMAT 6-E

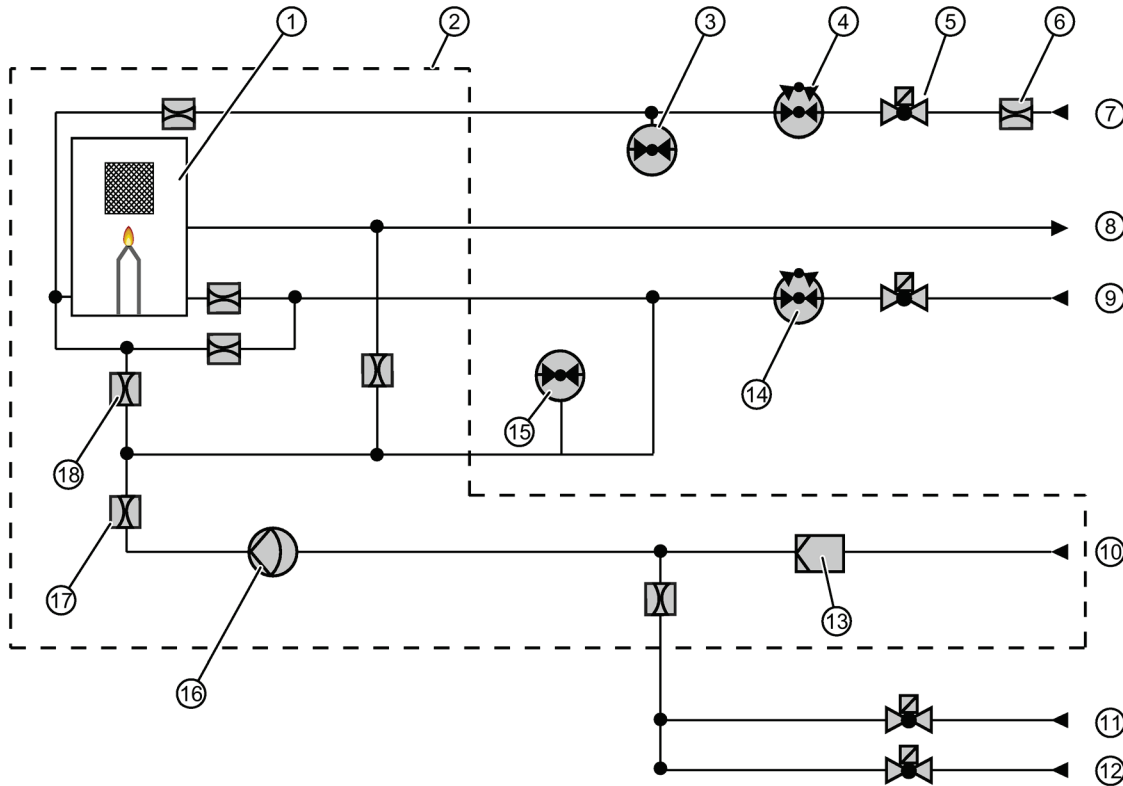

- |                                 |                                 |
|---------------------------------|---------------------------------|
| ① Sample chamber                | ⑩ Sample gas                    |
| ② Heated oven                   | ⑪ Zero gas                      |
| ③ Pressure sensor               | ⑫ Calibration gas               |
| ④ Mechanical pressure regulator | ⑬ Filter                        |
| ⑤ Solenoid valve                | ⑭ Mechanical pressure regulator |
| ⑥ Restrictor                    | ⑮ Pressure sensor               |
| ⑦ Combustion gas H <sub>2</sub> | ⑯ Pump                          |
| ⑧ Gas exhaust                   | ⑰ Damping                       |
| ⑨ Combustion air                | ⑱ Restrictor                    |

Figure 3-3 Gas flow FIDAMAT 6-E

### 3.5.2 Gas flow of the FIDAMAT 6-G

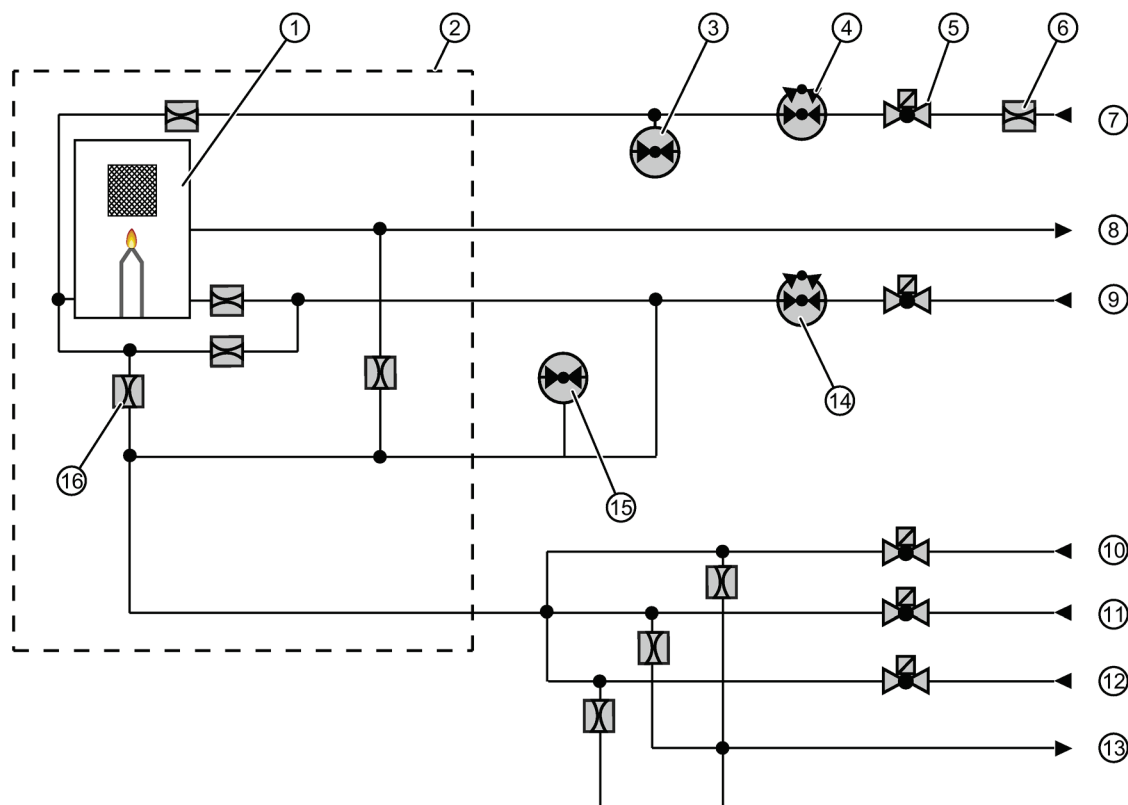

- |                                 |                                 |
|---------------------------------|---------------------------------|
| ① Sample chamber                | ⑨ Combustion air                |
| ② Heated oven                   | ⑩ Sample gas                    |
| ③ Pressure sensor               | ⑪ Zero gas                      |
| ④ Mechanical pressure regulator | ⑫ Calibration gas               |
| ⑤ Solenoid valve                | ⑬ Flushing outlet               |
| ⑥ Restrictor                    | ⑭ Mechanical pressure regulator |
| ⑦ Combustion gas H <sub>2</sub> | ⑮ Pressure sensor               |
| ⑧ Gas exhaust                   | ⑯ Restrictor                    |

Figure 3-4 Gas flow FIDAMAT 6-G

## **3.6 Communication**

### **3.6.1 General information**

This device provides the following communication options:

- ELAN interface (RS485 integrated)
- SIPROM GA (via the optional interface converter)
- PROFIBUS DP/PA (via the optional interface converter)
- USB interface (via the optional interface converter)

### **3.6.2 ELAN interface**

#### **ELAN interface**

ELAN is a standard integrated serial interface (RS485) which allows communication with several analyzers. It networks up to 12 analyzers.

The functional principle of the ELAN interface is shown in the following figure:



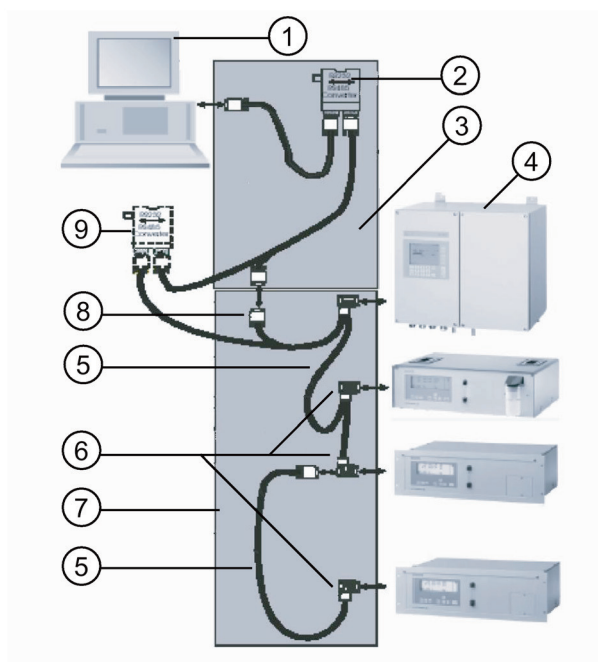

- |   |   |   |                          |
|---|---|---|--------------------------|
| ① | Computer  | ⑥ | RS485 bus connector      |
| ② | RS485 to RS232/USB/Ethernet converter with connecting cable | ⑦ | RS485 network            |
| ③ | RS485 bus connector with jumper                             | ⑧ | 9-pin Sub-D plug         |
| ④ | Analyzer  | ⑨ | Optional: RS485 repeater |
| ⑤ | RS485 cable   |   |                          |

Figure 3-5 Typical structure of an ELAN network (RS485)

## Interface parameters

Parameter	Value
Level	RS485
Baud rate	9600
Data bit	8
Stop bit	1
Start bit	1
Parity	None
No information feedback	

Product	Article number
RS485/RS232 converter	C79451-Z1589-U1
RS485/Ethernet converter	A5E00852383
RS485/USB converter	A5E00852382
SIMATIC cable/ bus cable	6XV1 830-0EH10
SIMATIC bus connector	6ES7972-0BB42-0XA0
9-pin Sub-D plug	6ES7972-0BB42-0XA0
Repeater	6ES7972-0AA02-0XA0

All converters are delivered with a driver CD which also contains the SIPROM GA software.

Further information can be found in the ELAN interface description with article number:

- C79000-B5200-C176 German
- C79000-B5276-C176 English

### 3.6.3 SIPROM GA

#### 3.6.3.1 SIPROM GA functions

SIPROM GA is a software tool especially for service and maintenance tasks. Many functions of analyzers, whether as a single device or several linked together, can be remotely operated and monitored this way.

The SIPROM GA software is available on the Internet and can be downloaded from the following address: SIPROM GA

(<https://support.industry.siemens.com/cs/ww/en/ps/17702/man>)

#### Functions

- Display and storage of device data
- Remote operation of device functions
- Parameter and configuration settings
- Comprehensive diagnostics information
- Remote calibration
- Online help
- Cyclic storage of measured values
- Status on hard disk and export to commercially available user programs
- Download of new software
- Drift values according to QAL 3, DIN EN 14181

### Hardware requirements

- PC/laptop Pentium 133 MHz, RAM 32 MB, CD-ROM drive
- At least 35 MB free disk space
- VGA graphics card supported by Windows
- Printer supported by Windows
- A free COM port with RS485 or one of the available converters for RS232/Ethernet/USB with respective connector is necessary for the connection.
- In the case of an RS485 network, the distance should not exceed 500 m. If this distance is exceeded, a repeater must be used.

### Software requirements

- Windows 7
- Windows 10

#### 3.6.3.2 Upgrading options

You can order the current device firmware as a chip set with the following article numbers:

<b>Firmware upgrades for older analyzers</b>	<b>Article number</b>
<b>FIDAMAT 6-E</b>	
German	A5E00223093
English	A5E00223146
French	A5E00223149
Spanish	A5E00223152
Italian	A5E00223155
<b>FIDAMAT 6-G</b>	
German	A5E00409885
English	A5E00409929
French	A5E00409947
Spanish	A5E00409962
Italian	A5E00409966

It is possible to upgrade the device firmware of older gas analyzers using the SIPROM GA software. Contact Service regarding this. You can find information on this in the section "Technical support (Page 175)".

### 3.6.4 PROFIBUS DP/PA

PROFIBUS DP/PA is the leading fieldbus on the market. All Siemens gas analyzers with an optional – also retrofittable – plug-in card are Profibus-compatible and comply with the binding "Device profile for analyzers" defined by the PNO (PROFIBUS International). Central access to the system analyzers is possible with the SIMATIC PDM software tool.

"Fieldbus" is the name of a digital communication system with which distributed field devices of a system are linked to each other over a single cable and are simultaneously connected to programmable controllers or a process control system.

The PROFIBUS-DP version is widespread in factory automation due to its high transmission speed per device, while PROFIBUS-PA takes the required properties of process engineering into account, such as use in hazardous areas.

The benefit is the considerable savings potential in all areas of the system, covering project planning and commissioning, operation and maintenance, up to subsequent system extensions.

Operation of the gas analyzers from a control system or a separate PC is possible with the SIMATIC PDM software tool (Process Device Manager). This software runs on Windows and can also be integrated in the SIMATIC PCS 7 process control system. With this, the integration of the devices in the system as well as the complex parameter structure of the analyzers can be clearly illustrated. Operating becomes simply a matter of "clicking".

PROFIBUS International (PNO) is an independent institution and represents the interests of many manufacturers and users. This organization offers services such as consulting, training and device certification, and understands its primary job as the further development, standardization and promotion of PROFIBUS technology. The binding functionality definition for a device class in the form of a profile is the condition for standardized device behavior from various manufacturers, the so-called interoperability. The binding profile for analyzers was defined at the end of 1999. With this, the interaction of all PROFIBUS-compatible devices of a system is guaranteed.

In this profile, the functionalities of the analyzers are defined in a block model: for example, the physical block describes the measuring procedure, analyzer and manufacturer name, serial number and the operating state (operation, maintenance). Different functional blocks contain the execution of certain functions, such as measured value and alarm processing. The transducer blocks describe the function of the actual measuring process, as well as its control, e.g. the pre-processing of a measured value, correction of cross-interferences, characteristics, measuring ranges, as well as switching and control processes. The data transmission between the bus participants is defined in protocols.

A distinction is made between cyclic and acyclic services. Time-critical data, such as measured values and status, are transmitted with cyclic services. The acyclic services allow device parameters to be queried or changed during operation.

All gas analyzers of Series 6 (ULTRAMAT 6, OXYMAT 6/61/64, CALOMAT 6/62 and FIDAMAT 6 as well as ULTRAMAT 23) are PROFIBUS-compatible with an optional plug-in card, which can also be retrofitted.

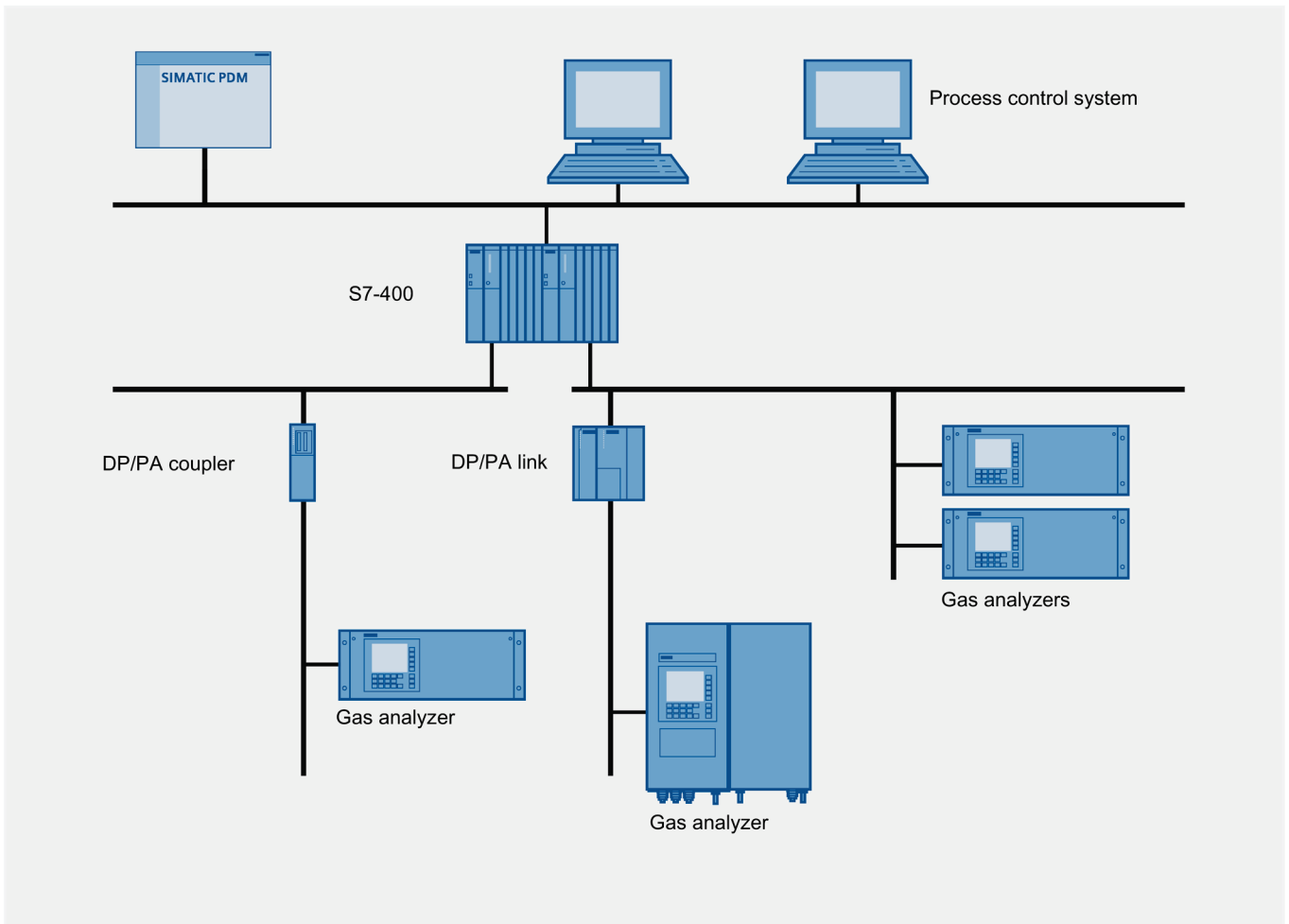



Figure 3-6 Typical structure of a PROFIBUS system

**See also**

Spare parts list (Page 146)



## 4.1 Safety information for installation

 <b>WARNING</b>
<b>Parts in contact with sample gases unsuitable for sample gas</b> Danger of injury or poisoning, device damage Hot, poisonous and corrosive sample gases can be released at the connections if the device parts and accessories coming into contact with sample gas are unsuitable for the sample gas. <ul style="list-style-type: none"><li>• Use only sample gas-contacting connecting parts (pipes, unions and sealing material) that are suitable for the connection and for the sample gases. Refer to the information in the section "Technical specifications".</li></ul>

 <b>WARNING</b>
<b>Introduction of combustible gases</b> Danger of explosion The device is <b>not</b> designed for measurement of ignitable gas mixtures. <ul style="list-style-type: none"><li>• If the device is used to measure flammable gases that can combine with air or oxygen to form an ignitable gas mixture, take special explosion protection measures!</li></ul>

<b>NOTICE</b>
<b>Improper installation</b> The device can be damaged or destroyed or its functionality impaired through an incorrect installation. <ul style="list-style-type: none"><li>• Make sure before installing the device that there is no visible damage.</li><li>• Ensure that the process connections are clean and that the seals and cable glands are suitable.</li><li>• Mount the device using a suitable tool.</li></ul>

<b>NOTICE</b>
<b>Direct sunlight</b> Device damage The device can overheat or materials become brittle through the influence of UV radiation. <ul style="list-style-type: none"><li>• Protect the device from direct sunlight.</li><li>• Make sure that the maximum permissible ambient temperature is not exceeded. For more information on this, see section "Technical specifications (Page 167)".</li></ul>

## 4.2 Mounting instructions

---

### Note

#### Layout of the installation location

The installation location should be:

- Easily accessible
  - Shock-free and vibration-free
  - Within the ambient temperature limits
- 

---

### Note

#### Weatherproof installation

Install the device at a location where it is protected against:

- Direct heat and solar radiation
  - Mechanical damage
  - Vibrations
  - Contamination
  - Intrusion of dust
  - Corrosive media
  - Moisture
  - Significant and rapid temperature fluctuations
  - Strong air flow
-



## 4.3 Cabinet installation

If you install the FIDAMAT 6 in a cabinet or a table-top housing, the device's own weight places too high a load on the chassis. For this reason, it is insufficient to mount only the front side of the device. In this case, the procedure is as follows:

- Place the device for mounting on support or telescopic rails. Installation in a hinged frame is also possible.
- Only use supports that accommodate the weight of the device.
- Secure the housing with all four screws.

## 4.4 Ventilation of the device

Although the FIDAMAT 6 has an built-in fan, you must provide for adequate ventilation.

If several devices are placed in a cabinet, install the FIDAMAT 6 at the top due to its high heat emission. Alternatively, ensure there is a clearance of at least 4 to 5 cm (1 height unit) above the device.

Because of the heat emission of the device, a clearance of at least 2 cm from the cabinet wall and from installed electrical cables is required.





# Connecting

## 5.1 Safety information for connecting

 <b>WARNING</b>
<b>Hazardous contact voltage</b> Risk of electric shock in case of incorrect connection. <ul style="list-style-type: none"><li>• For the electrical connection specifications, refer to the information in Technical specifications (Page 167).</li><li>• At the mounting location of the device observe the applicable directives and laws for installation of electrical power installations with rated voltages below 1000 V.</li></ul>

 <b>WARNING</b>
<b>Missing PE/ground terminal</b> Danger of electrocution If there is no ground terminal, there is a risk of electrocution. Depending on the device version, connect the power supply as follows: <ul style="list-style-type: none"><li>• Power plug: Ensure that the used socket has a PE/ground terminal. Check that the PE/ground terminal of the socket and power plug match.</li><li>• Connecting terminals: Connect the terminals according to the terminal assignment table. Connect the PE/ground conductor first.</li></ul>

 <b>WARNING</b>
<b>Introduction of toxic, corrosive or flammable gases</b> The limited release of toxic or corrosive gases during their introduction cannot be avoided with absolute certainty. <ul style="list-style-type: none"><li>• Before toxic, corrosive or flammable gases are introduced, carry out a leak test for the pipe connections.</li><li>• Flush the device with oil-free and dry purge air or inert gas.</li><li>• Collect the emerging purging gas for environmentally-friendly disposal with a suitable device.</li></ul>

 <b>WARNING</b>
<b>Leakiness of gas path</b> Danger of poisoning Leaky gas paths lead to accumulation of the sample gas in the device. <ul style="list-style-type: none"><li>• Tighten the unions in accordance with the mounting specifications of the manufacturer using a suitable open-ended wrench. In the process, make sure that you counter properly.</li><li>• Use only sample gas-contacting connecting parts (pipes, unions and sealing material) that are suitable for the connection and for the sample gases.</li></ul>

 <b>CAUTION</b>
<b>Cable damage</b> This device radiates heat. <ul style="list-style-type: none"><li>• For this reason, route all electrical cables at least 2 cm away from the device housing.</li></ul>

## 5.2 Gas and electrical connections on the device

### Gas connections

Bulkhead unions for pipes with an outside diameter of 6 mm or ¼" are present as gas connections. For the gas connection assignment, refer to the gas flow diagrams and the marking on the rear panel of the housing.

### Electrical connections

All connecting cables (except for the power supply cord) must be shielded.

The connected cables are shielded via the plug connections.

The core cross-section should be  $\geq 0.5 \text{ mm}^2$ . Cables of type JE-LiYCY...BD are recommended. The cable length of the analog output depends on the load.

## Connections of the FIDAMAT 6-E

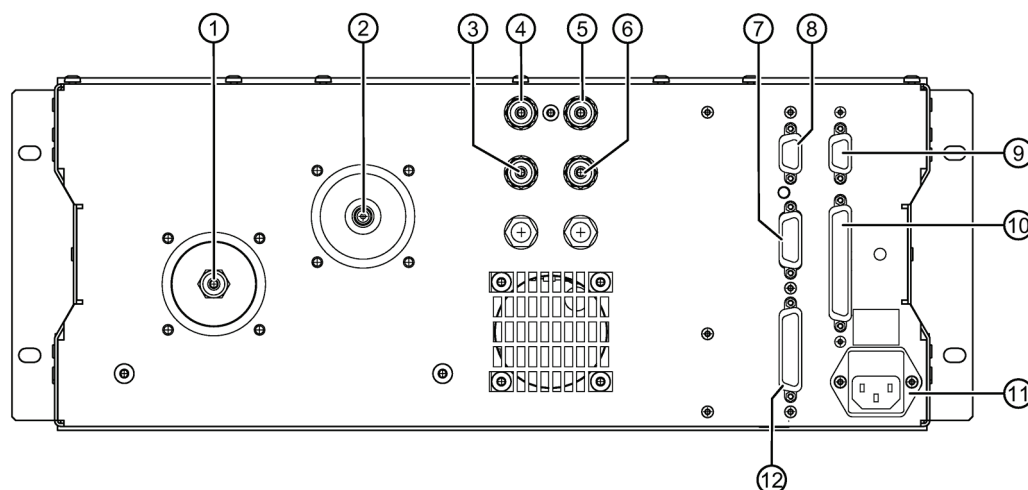

- |   |  |
|---|--|
| ① Sample gas inlet, pipe union 6 mm or 1/4" | ⑦ 15-pin socket: Binary inputs and analog inputs/outputs       |
| ② Sample gas exhaust, nozzle, 6 mm or 1/4"  | ⑧ 9-pin socket: ELAN, RS485                                    |
| ③ Calibration gas, pipe union 6 mm or 1/4"  | ⑨ 9-pin interface socket (optional, e.g. PROFIBUS)             |
| ④ Combustion gas, pipe union 6 mm or 1/4"   | ⑩ 37-pin socket: Binary inputs and relay outputs (option card) |
| ⑤ Combustion air, pipe union 6 mm or 1/4"   | ⑪ Network connection and micro fuses                           |
| ⑥ Zero gas, pipe union 6 mm or 1/4"         | ⑫ 25-pin socket: Binary inputs and relay outputs               |

Figure 5-1 Gas and electrical connections of the FIDAMAT 6-E

### Connections of the FIDAMAT 6-G

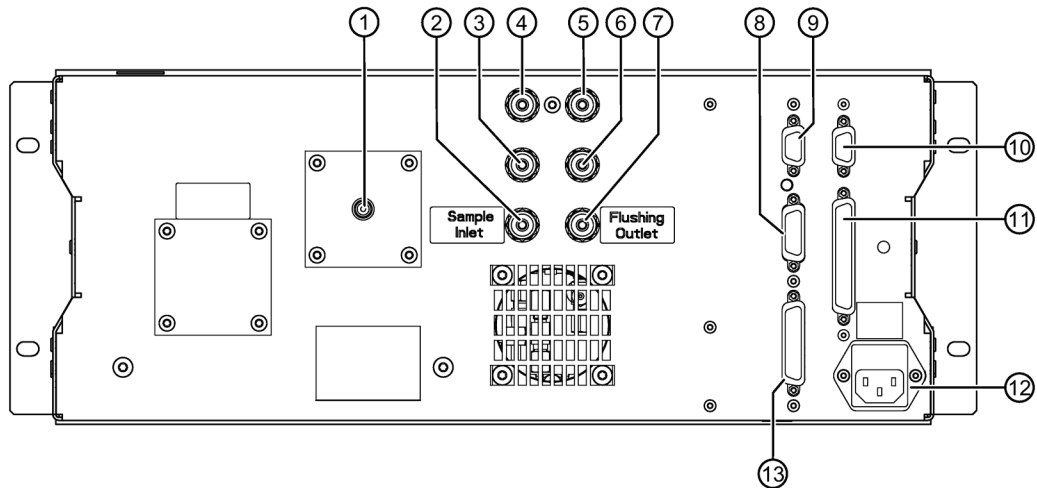

- |   |  |
|---|--|
| ① Sample gas exhaust, nozzle, 6 mm or 1/4"  | ⑧ 15-pin socket: Binary inputs and analog inputs/outputs       |
| ② Sample gas inlet, pipe union 6 mm or 1/4" | ⑨ 9-pin socket: ELAN, RS485                                    |
| ③ Calibration gas, pipe union 6 mm or 1/4"  | ⑩ 9-pin interface socket (optional, e.g. PROFIBUS)             |
| ④ Combustion gas, pipe union 6 mm or 1/4"   | ⑪ 37-pin socket: Binary inputs and relay outputs (option card) |
| ⑤ Combustion air, pipe union 6 mm or 1/4"   | ⑫ Network connection and micro fuses                           |
| ⑥ Zero gas, pipe union 6 mm or 1/4"         | ⑬ 25-pin socket: Binary inputs and relay outputs               |
| ⑦ Flushing outlet                           |  |

Figure 5-2 Gas and electrical connections of the FIDAMAT 6-G

## 5.3 Gas connections

### Sample gas line

For the gas supply and discharge lines, there is one directly heated inlet (sample) and one directly heated outlet each. Separately heated sample gas supply lines each require their own power supply and temperature regulation.

The hexagon of the bulkhead unions is seated in an anti-rotation lock. When tightening the union nuts on the unions, always ensure that you counter-hold properly with a suitable open-end wrench. Otherwise there is a danger that the gas path will leak.

**FIDAMAT 6-E:** The sample gas is drawn in by a diaphragm pump with a capacity of approximately 1 l/min. Ensure that the sample gas is at atmospheric pressure. However, the device can also be operated at a constant overpressure or underpressure of up to 100 hPa.

**FIDAMAT 6-G:** The sample gas is supplied unheated by a solenoid valve.

## Pressure sensors

The FIDAMAT 6 has two internal pressure sensors for measuring the sample gas pressure (= combustion air pressure) and the combustion gas pressure.

## Sample gas path in the device (containment system)

Materials that come in contact with the sample gas must be resistant to it. The gas paths and gaskets are made of stainless steel 1.4571 / 1.4404 (gas outlets), graphite and/or PTFE.

To guarantee the leak-tightness of the containment system, perform a periodic leak test. If leaks are discovered, eliminate the cause before restarting measurements. Replacement of gaskets is one possible action for this.

---

### Note

Always perform a leak test after service work on the containment system. For more information, refer to the section "Checking for leaks (Page 56)".

---

## 5.3.1 Connecting gas

Proceed as follows:

1. Connect the gas lines to the associated gas inlets and outlets using suitable bulkhead unions.  
When tightening the union nuts at the gas connection fittings, make sure that you counter properly.
2. Check the bulkhead unions for secure connection and check the pipe unions for leaks (Page 56).

## 5.3.2 Sample gas disposal

---

### Note

#### Environmentally responsible disposal

If the gases released in this way are toxic or otherwise harmful to health, it is essential that they are discharged in such a way that no risk is posed to human health or the environment.

---

The majority of the supplied sample gas is routed via a bypass to the gas exhaust.

If the exhaust gas is to flow off into a collection line, observe the following points:

- Keep the flow resistance in the collection line as low as possible by using a short line or by using a transition to a larger diameter.
- The exhaust gas line must be free of rapid pressure fluctuations. In case of pressure fluctuations, take the following remedial actions:
  - Install a separate exhaust line.
  - Alternatively: Install a damping vessel (> 1 l) with a downstream restrictor between the device and the exhaust line (pneumatic low pass).
- Route the line with a constant downward gradient to prevent congestion in the exhaust gas line (e.g. due to water condensation) and therefore damage to the device due to water formation. We recommend connection of a siphon as a water separator. The exhaust gas line connected to the device must have an inside diameter of at least 8 mm due to condensate formation.

## 5.4 Electrical connection

### 5.4.1 Notes for electrical connections

---

#### Note

##### Improvement of interference immunity

- Lay signal cables separately from cables with voltages > 60 V.
  - Use cables with twisted wires.
  - Install the device and lay its cables at a distance to strong electromagnetic fields.
  - Use shielded lines to guarantee the full specification according to Ethernet/PROFIBUS.
- 

#### Note

##### Securing plug-in connections

Plug-in connections without interlock can loosen and fall out.

- Secure plug-in connections without interlock mechanically, for example, with a cable tie.
-



## 5.4.2 Connecting signal cables

<b>NOTICE</b>
<b>Device damage</b>
Only connect the signal lines to devices that are protected by electrical separation from their auxiliary power.

- Connect the signal lines to the D-sub connectors on the rear of the device.
- The connecting cables to the relay outputs, the binary inputs, the analog inputs and the analog output must be shielded. Connect these to the corresponding trapezoidal connectors (D-sub connectors) in accordance with the terminal diagrams.
- The reference ground of the analog inputs is the potential of the housing.
- The analog output is floating.
- The shielding of the interface cable must be at the potential of the housing. Connect the shield of the cable to the shield of the D-sub connector over a large area. The core cross-section must be  $\geq 0.5 \text{ mm}^2$ . The length of the interface cable must not exceed 500 m.

---

**Note**

All connecting cables (except for the power supply cord) must be shielded. The shields of the connected cables must be connected to the respective screw fittings continuously over a large area. The core cross-section must be  $\geq 0.5 \text{ mm}^2$ . We recommend cables of type JE-LiYCY...BD. The cable length of the analog output depends on the load.

---

**See also**

Plug connector assignment of the optional board and PROFIBUS (Page 50)

### 5.4.3 Connecting the power supply

The device comes with an appliance connector that may only be connected to the power cord by qualified personnel. The power cord must comply with the regulations and requirements applicable at the place of installation and be provided with a protective conductor at the potential of the housing. The cross-section of each wire must be  $\geq 1 \text{ mm}^2$ .

Route the power cable separately from the signal lines.

Provide a power disconnection device in the direct vicinity of the device (for load rating, see rating plate). It must be readily accessible and marked.

Check whether the available line voltage agrees with that specified on the rating plate.

#### Procedure

1. Connect the wires of the connecting cable to the IEC plug at the marked spot. Make sure that the line conductor, the neutral conductor (N) and the protective conductor (PE) are connected correctly!  
Tighten the screws in the IEC plug with the following torques:
  - 0.5 Nm at the terminal clamps
  - 0.3 Nm at the line terminals (strain relief) and the connector enclosure
2. Connect the IEC plug.

### 5.4.4 Circuit diagrams (pin assignment)

#### 5.4.4.1 Motherboard pin assignments

Connector D-SUB 9F (RS 485)

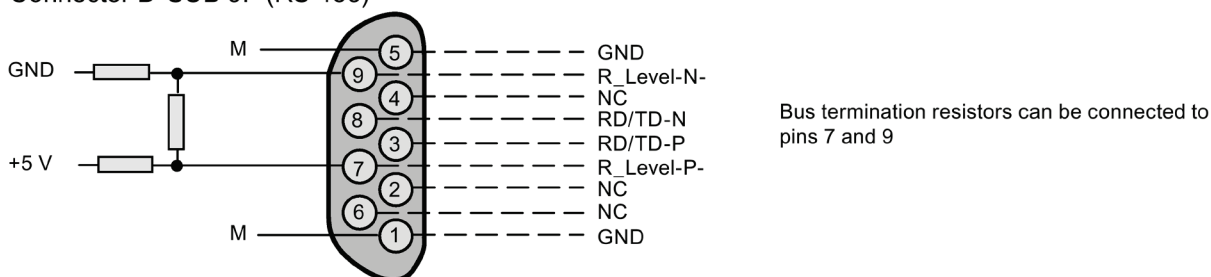

Connector D-SUB 15F

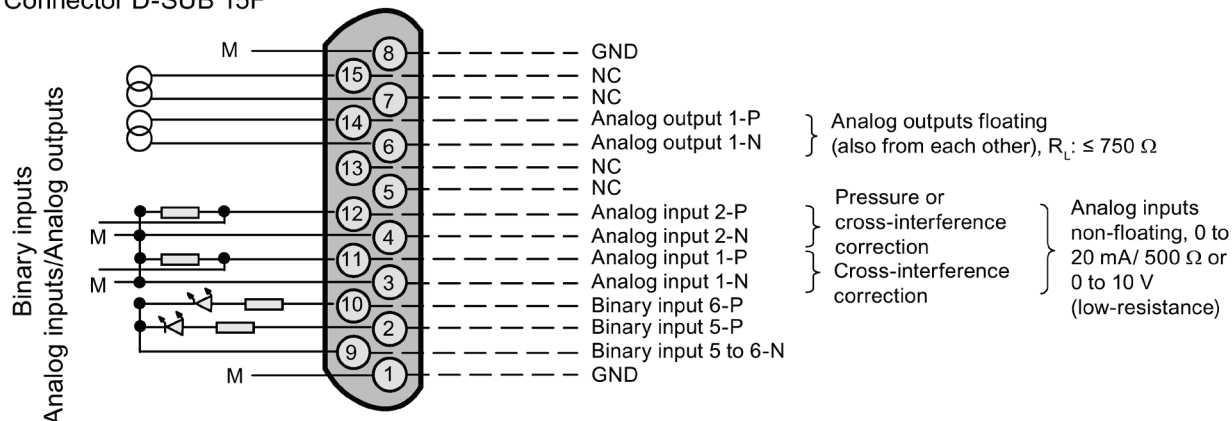

Connector D-SUB 25F

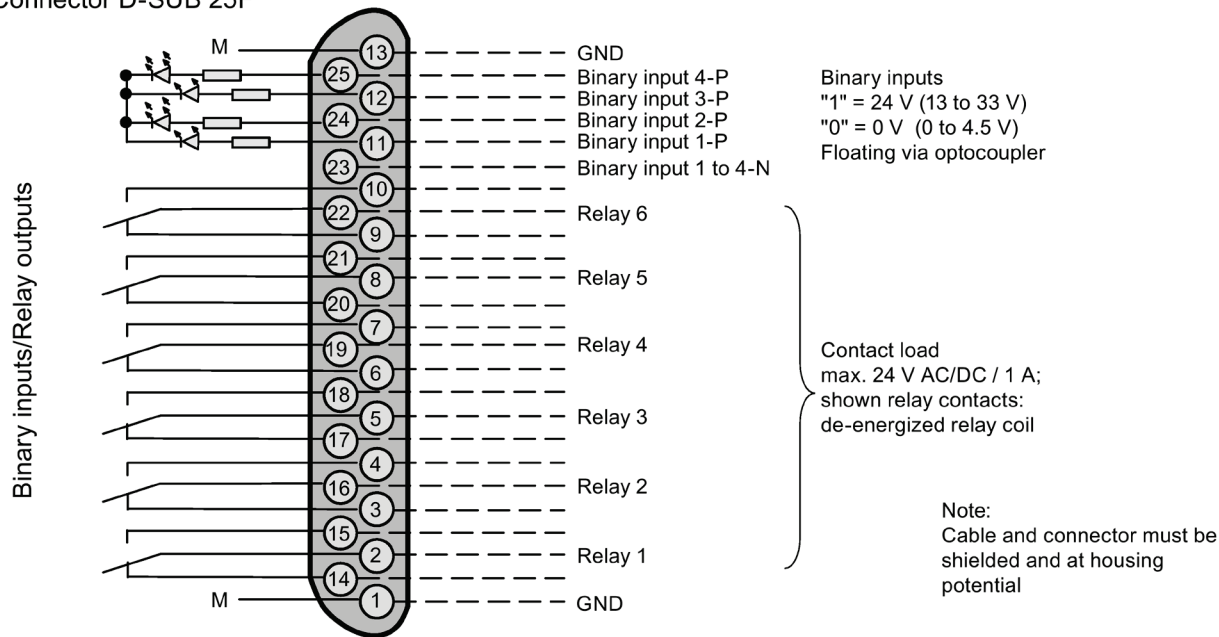

Figure 5-3 Motherboard pin assignment

5.4.4.2 Plug connector assignment of the optional board and PROFIBUS

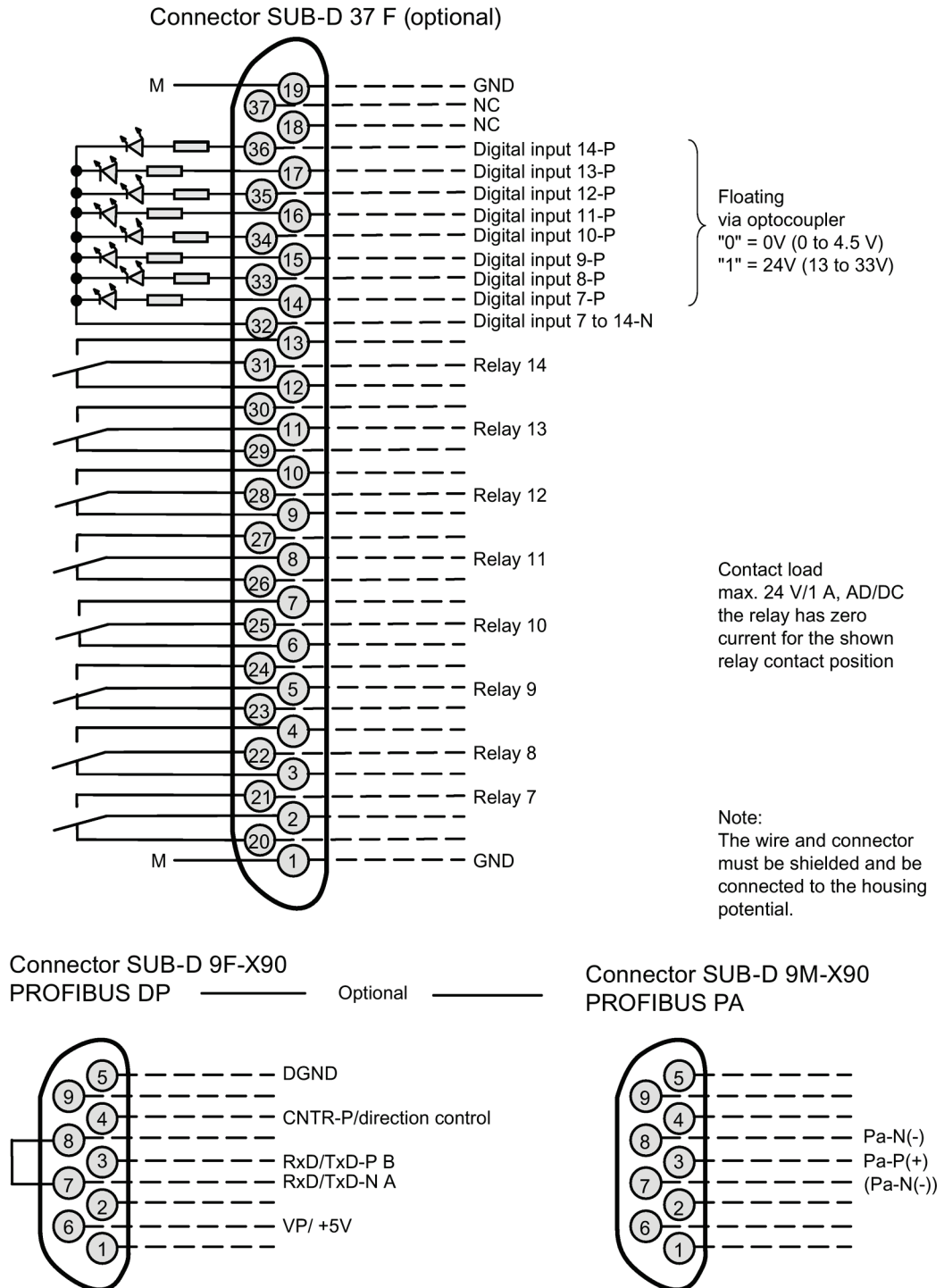

Figure 5-4 Pin assignment of the option board and PROFIBUS connector, 19" rack unit

### 5.4.4.3 ELAN interface cable

#### Specification of the interface cable

Parameter	Value
Wave impedance	100 to 300 $\Omega$ for a measuring frequency of > 100 kHz
Cable capacitance	Typ. < 60 pF per meter
Core cross-section	> 0.22 mm <sup>2</sup> , corresponds to AWG 23
Cable type	Twisted pair, 1x2 conductors
Signal attenuation	Max. 9 dB along the entire length of the cable section
Shielding	Copper braided shield or braided shield and foil shield

#### Bus terminating resistors

For connection of bus terminating resistors, place a jumper from pin 3 to pin 7 and from pin 8 to pin 9 in the first and last connector of a bus cable (see figure "Pin assignment").

#### Note

For a cable length greater than 500 m or in the case of high interferences, we recommend that a repeater be installed. For additional information, refer to the ELAN interface description.

**Article numbers:**

- C79000-B5200-C176 German
- C79000-B5276-C176 English

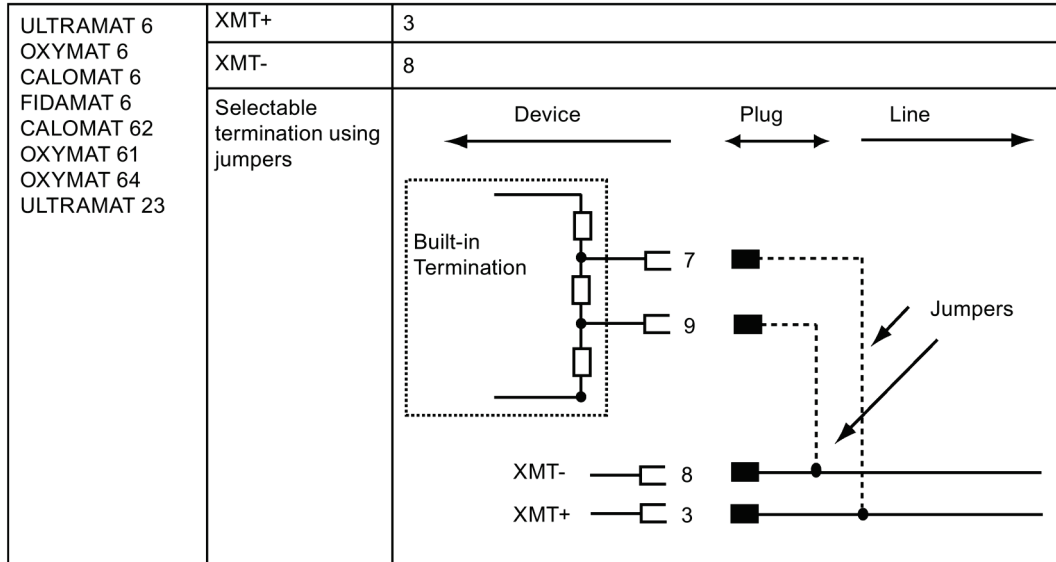



Figure 5-5 Pin assignment

**See also**

ELAN configuration (function 73) (Page 115)

# Commissioning

## 6.1 Safety information for commissioning

 <b>WARNING</b>
<b>Introduction of combustible gases</b> Danger of explosion The device is <b>not</b> designed for measurement of ignitable gas mixtures. <ul style="list-style-type: none"><li>• If the device is used to measure flammable gases that can combine with air or oxygen to form an ignitable gas mixture, take special explosion protection measures!</li></ul>

 <b>WARNING</b>
<b>Dangerous concentration of hydrogen</b> Danger of explosion Hydrogen (H <sub>2</sub> ), among others, serves as a supply gas for operation of the FIDAMAT. Hydrogen combines with the oxygen in ambient air to form an explosive gas mixture. Because hydrogen is usually supplied from high-pressure gas cylinders, you must ensure that the quantity of hydrogen needed is limited. <ul style="list-style-type: none"><li>• Ensure limiting of the hydrogen quantity, e.g. by using a suitable reducing valve.</li></ul>

 <b>WARNING</b>
<b>Leaking of toxic gases from exhaust gas lines</b> Danger of poisoning When toxic or aggressive gases are measured, they may be released through leaky exhaust gas lines. <ul style="list-style-type: none"><li>• Use parts made of sample-gas-resistant material for the exhaust gas lines (see section Design of the device (Page 21)).</li></ul>

 **WARNING**

**Leakiness of gas path**

Danger of poisoning

Leaky gas paths lead to accumulation of the sample gas in the device.

- Tighten the unions in accordance with the mounting specifications of the manufacturer using a suitable open-ended wrench.  
In the process, make sure that you counter properly.
- Use only sample gas-contacting connecting parts (pipes, unions and sealing material) that are suitable for the connection and for the sample gases.



 **CAUTION**

**Hot surfaces due to hot sample gases and high-temperature devices**

Danger of burns due to surface temperatures above 70 °C (155 °F)

The inside of the oven reaches a temperature of approximately 200 °C during operation. After being switched off, the device and its parts are still very hot and the temperature only drops very slowly. You can call up the actual temperature of the oven and other temperature parameters via the Diagnostic values (function 2) (Page 77).

Contact with skin may result in burns.

- Wait until the device has cooled down before starting maintenance work or decommissioning.
- Take appropriate protective measures during maintenance, e.g. contact prevention.



 **CAUTION**

**Hot surfaces resulting from hot sample gases and heated devices**

Danger of burns resulting from surface temperatures above 70 °C (155 °F).

- Take appropriate protective measures, for example contact protection.
- Make sure that the maximum ambient temperature is not exceeded by implementing protective measures. Refer to the information in the section "Technical specifications (Page 167)".



## **6.2 Preparation for commissioning**

### **6.2.1 General information for commissioning**

#### **Device position**

The FIDAMAT 6 may only be operated in a horizontal position.

#### **Operation**

Before connecting and switching on the device, the operator must have made himself familiar with the device operation.

#### **Interfaces**

Before use, the interfaces must be correctly allocated and parameterized.

#### **Noise damping**

The output signal fluctuations caused by noise in the measured signal can be reduced using function 50. This function offers you the option of parameterizing a low-pass filter which can be assigned a time constant up to 300 s.

#### **Temperature influence**

During operation, make sure that the permissible ambient temperature of 5 °C to 45 °C is observed.

### **6.2.2 Gas preparation**

#### **6.2.2.1 Supply gas**

The FIDAMAT 6 is often used to measure hydrocarbons with a concentration of less than 1 ppm. The supply gases (combustion gas, combustion air and zero gas) must have a degree of purity of 5.0 (= 99.9990%) in order to guarantee correct measurements. The higher the purity of the supply gases, the lower the zero current and thus the noise that defines the lower detection limit. If the measured value of the sample gas is less than the measured value of the zero gas, for example, the zero gas is contaminated or the contamination comes from the gas supply lines or other parts outside the FIDAMAT 6.

If plastic tubes (including PTFE) are used, the diffusion of hydrocarbons through the walls must also be considered. Therefore, supply gas supply lines made of high-purity steel or copper pipes must be used for measurements of low concentrations.

The degree of purity must be increased (e.g. up to 6.0) in the case of very low hydrocarbon concentrations (< 1 ppm). Adapt the purity level of the zero gas to suit the measurement task, e.g. by re-cleaning using a molecular sieve, activated-carbon filter or catalyst that is connected directly to the gas inlets of the FIDAMAT 6 with purified metallic connections.

Make the supply gases available at a relative primary pressure between 2000 and 4000 hPa. The pressure of the zero gas and calibration gas is 3000 hPa. Higher pressure will result in increased gas consumption, while lower pressure may result in an incorrect calibration because sample gas can additionally be drawn in.

**Requirements for the combustion air**

Hydrocarbons contained in the combustion air may impair the accuracy of measurements because the hydrocarbon content is included in the measurement as an error. For this reason, the combustion air must be as free of hydrocarbons as possible.

To minimize the effect of hydrocarbons in the combustion air on the measuring results, use combustion air with the following quality:

Particulate class	2
Water class	3
Dew point	≤ -20 °C
Oil class	1 or < 0.01 mg/m <sup>3</sup>
Impurity:	
Total hydrocarbons (oil residues and higher hydrocarbons C1-C5 combined)	< 0.1 ppm

If you use compressed air as combustion air, purify it before the measurement, e.g. with a 2-stage oil filter (activated carbon) or an air treater.

**6.2.2.2 Sample gas**

**Note**

The sample gases must be supplied to the analyzer dust-free. To prevent condensation, it is necessary in most applications to use a gas preparation system adapted to the measuring task.

**FIDAMAT 6-E:** The sample gas is drawn in across a sample gas filter heated to a maximum of 200 °C (392 °F) that acts as a secondary filter for the gas. The filter is made of sintered metal (CrNi steel), has a pore width of 30 µm and an area of 3 cm<sup>2</sup>.

**FIDAMAT 6-G:** The sample gas is supplied unheated by a solenoid valve.

**6.2.3 Checking for leaks**

Before putting the device into operation each time and after every maintenance activity affecting the flame ionization detector (FID) or the gas path, you must check the device for leaks.

## Procedure

1. Connect the gas outlet to a relative pressure manometer (0 to 1000 hPa, resolution 1 hPa).
2. Generate an overpressure of approximately 750 hPa for about one minute and then stop.
3. Wait about 10 minutes until the pressure has equalized. Then record the pressure.
4. Wait another minute, and read off the pressure again.

If the pressure drop within one minute does not exceed 12 hPa, the gas path is sufficiently tight.

---

### Note

During the measurement, the gas path, including the FID, must have a constant temperature.

---

### Test conditions:

The specified pressures are relative pressures.

### Calibration gas:

Synthetic air (sample gas path must not be contaminated)

### Test pressure:

Operating pressure x 1.5 (operating pressure = 500 hPa)

### Device electrically switched off:

	Test pressure [hPa] relative	Permissible pressure drop $\Delta p$ [hPa] relative
Sample gas path	750 +10	$\Delta p$ 12
Supply gas inlets	3000 +100	$\Delta p$ 17

### Pressure equalization times: Chronological test sequence

---

### Note

After applying the test pressure, note the start and end of the measurement for determining  $\Delta p$ .

---

	Start of measurement x min after applying test pressure	End of measurement y min after applying test pressure
Sample gas path	2	3
Supply gas inlets	1	2

## 6.3 Commissioning and operation

### Procedure

1. Before you switch on the device, ensure the following:
  - All required gas lines are connected to the device and have been checked for leak tightness and strength with an overpressure.
  - Combustion gas, combustion air, zero gas and calibration gas are connected and the required pressures are set.
2. Switch on the device.  
The measured value display appears shortly thereafter on the control panel display. Above it (in the top line) is the status display (see User interface and operating modes (Page 65)).
3. Wait approximately one hour until the warm-up phase of the device is complete.  
To prevent blocking the automatic warm-up process, the device must always be in measuring state. The current operating state can be read in the bottom line.

### 6.3.1 Warm-up phase

The device requires a warm-up phase of approximately one hour from its cold state.

---

#### Note

Do not change any pressures during the warm-up phase.

---

### Warm-up phase

The following sequence only applies if you have not activated another start-up state in function 91.

#### Sequence of the warm-up phase

During the warm-up phase, the device runs through the warm-up steps in the following order:

1. Oven in heating phase  
In this phase, the oven warms up (temperature can be called using function 2 "Diagnostic values").
2. Chamber in heating phase  
The FID is being warmed up.
3. Combustion gas test  
The device checks the combustion gas supply.

#### 4. Combustion air test

The device checks the combustion air pressure.

#### 5. Igniting

The flame is automatically ignited. The flame burns when the flame temperature is approximately 20 °C higher than the oven temperature (can be called under function 2 "Diagnostic values").

During the warm-up phase, "WARMUP" appears in the bottom line of the measured value display, alternately with the current warm-up step.

**FIDAMAT 6-E:** When the device has detected that the flame is burning, the pump is switched on and the analyzer is set to "Measuring" operating state.

**FIDAMAT 6-G:** When the device has detected that the flame is burning, the control system sets the device to "Standby" operating state. The control system switches to the "Measuring" operating state only when you turn on the zero gas, calibration gas or sample gas using function 62 (or function 72 "Binary inputs") and the sample gas pressure (consisting of "zero gas, calibration gas or sample gas" in conjunction with "combustion air") has exceeded the value 485 hPa (can be set using function 92).

### 6.3.2 Operating states

#### 6.3.2.1 Operating state of the FIDAMAT 6-E

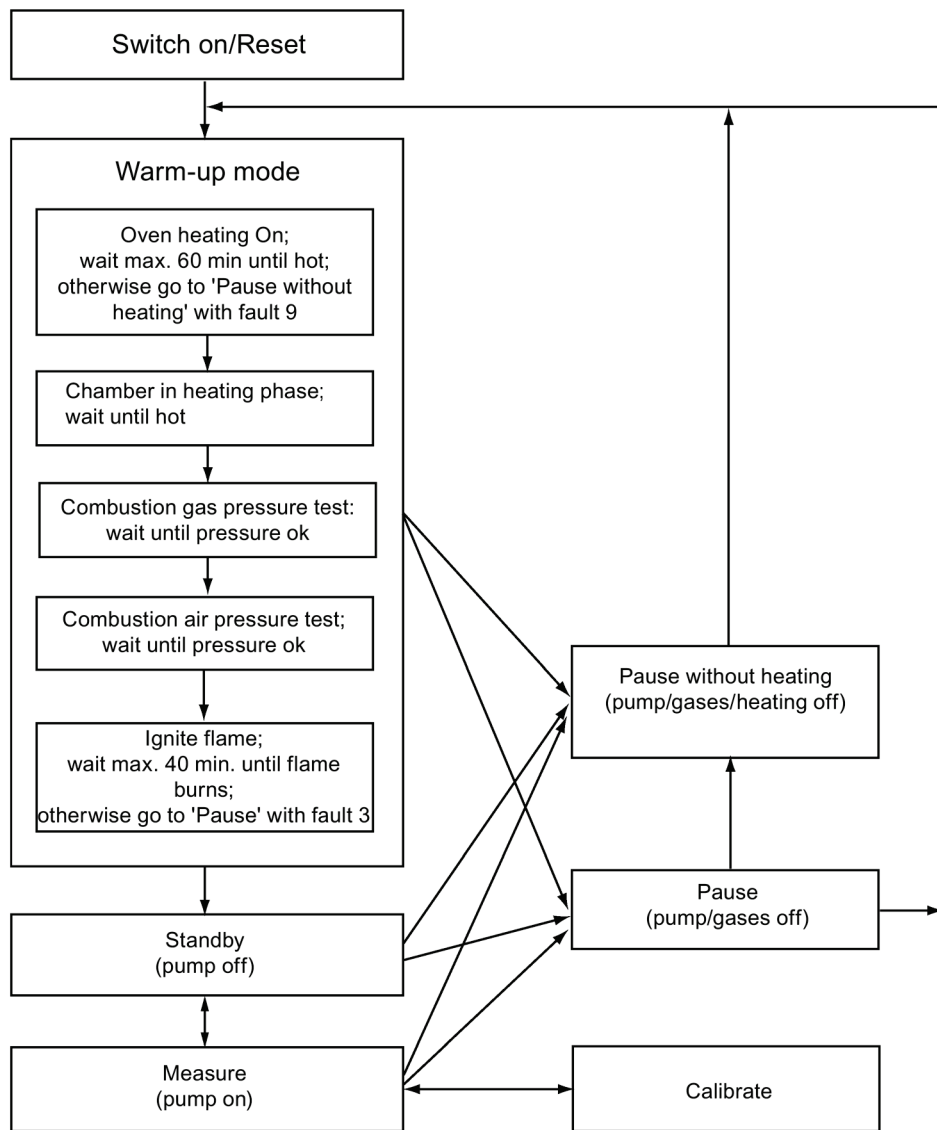

Figure 6-1 Operating states of the FIDAMAT 6-E

You can manually set another start-up state using function 91. The start-up state is automatically changed by faults/maintenance requests that occur.

6.3.2.2 Operating state of the FIDAMAT 6-G

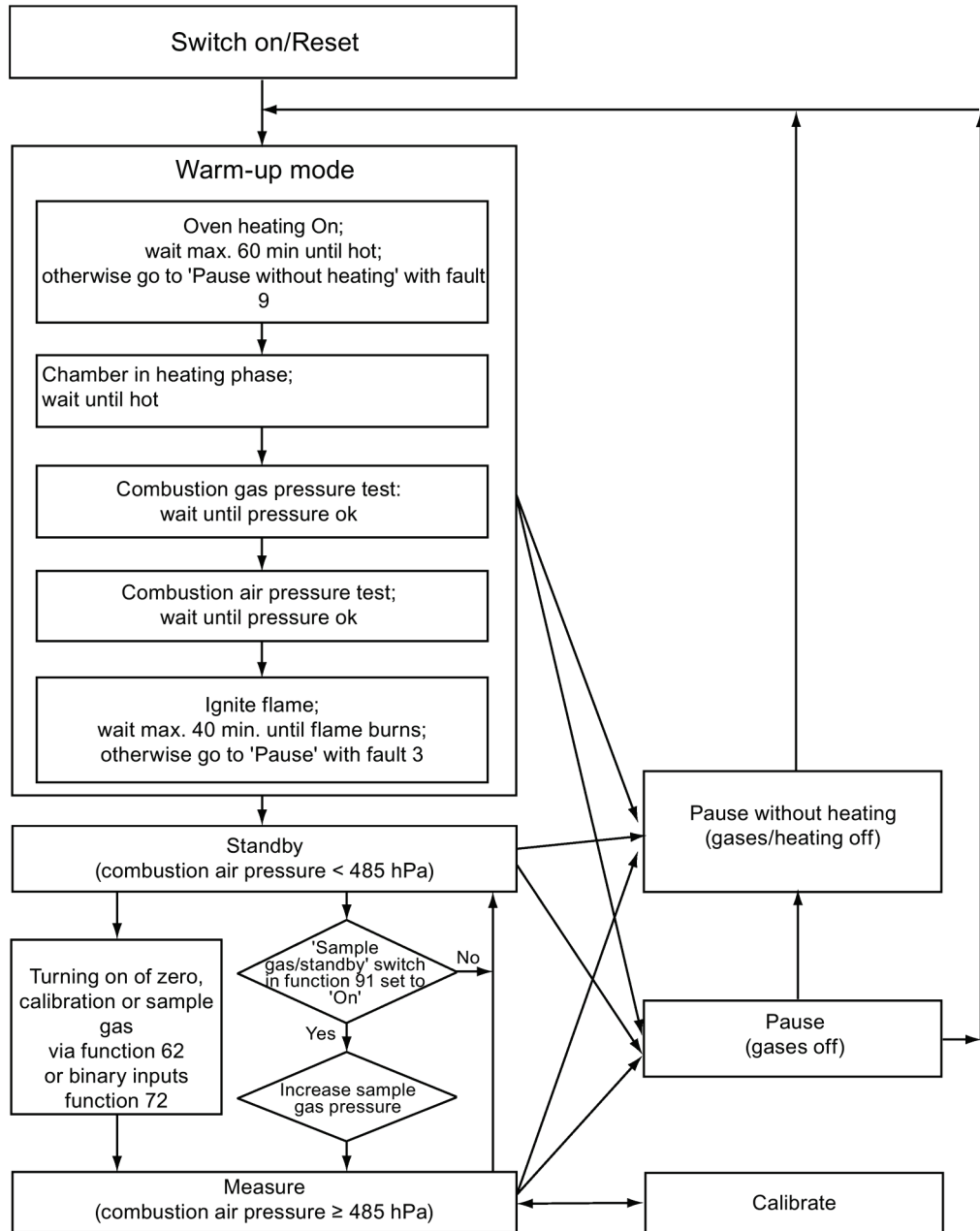

Figure 6-2 Operating states of the FIDAMAT 6-G

You can manually set another start-up state using function 91. The start-up state is automatically changed by faults/maintenance requests that occur.

### 6.3.3 State change due to fault / maintenance request

In the following tables, you will find possible automatic state changes of the device:

Table 6- 1 Change of state due to fault

Fault	Last state	New state
S1: Parameter memory	- - -	
S2: Pump does not start up (FIDAMAT 6-E only)	Warming-up   Standby	Standby
S3: Flame does not ignite	Warming-up	Pause
S4: External fault	- - -	
S5: Oven temperature	Warming-up   Standby   Measuring   Pause	Pause without heating
S7: Flame temperature	Warming-up   Standby   Measuring   Pause	Pause
S8: Combustion air/combustion gas pressure	Warming-up   Standby   Measuring   Pause	Pause
S9: Heating is off	Warming-up	Pause without heating
S10: 24 h RAM/Flash check	- - -	
S12: Line voltage supply	Warming-up   Standby   Measuring   Pause	Pause
S13: Hardware	Warming-up   Standby   Measuring   Pause	Pause
S14: Measured value > Full-scale value of characteristic	- - -	
S15: Calibration aborted	- - -	

Table 6- 2 Change of state due to maintenance request

Maintenance request	Last state	New state
W1: Calibration difference too great	- - -	
W4: Set clock	- - -	
W5: Combustion air/combustion gas pressure	Standby   Measuring	Warming-up
W6: Temperature sensor display	- - -	
W7: Electronics/hardware temperature	- - -	
W8: Flame is out	Standby   Measuring	Warming-up
W9: External maintenance request	- - -	
W10: AUTOCAL check deviation	- - -	

After you have eliminated the cause of a maintenance request or fault, exit the current operating state using function 91.



## 6.3.4 Measuring ranges

### Measuring ranges/spans

The desired spans (start-of-scale and full-scale values of measuring range) can be specified with function 41. The start-of-scale and full-scale values are assigned to the analog current values 0/2/4 mA and 20 mA.

If you enter the same values for the start-of-scale and full-scale of a measuring range, this range is considered as non-existent. Assign the smallest measuring span (MS) to measuring range 1 and the next larger one in each case to measuring ranges 2 – 4. In general, the following applies to the assignment:  $MS1 < MS2 < MS3 < MS4$ .

### Zero setpoint

Enter the setpoint of the zero point under function 22. It applies to all measuring ranges.

### Zero calibration

You calibrate the zero point with function 20. The device displays both the setpoint and actual value.

### Electronically suppressed zero

If the start-of-scale value (ppm, vol%, etc.) is not at a concentration of zero, this is called a measuring range with suppressed zero, e.g. 200-300 ppm THC. In this case, 200 ppm is the start-of-scale value, 300 ppm the full-scale value and the span is 100 ppm.

Channels with electronic zero suppression are physically identical with non-suppressed zeros. They only differ in the configured measuring ranges and setpoint for the suppressed zero (e.g. 200 ppm THC). The characteristic is stored from zero up to the full-scale value of the characteristic (in accordance with the rating plate). You can reconfigure devices with non-suppressed zeros by subsequently reassigning these parameters to suppressed zeros (functions 22 and 41). Note, however, that influences such as noise, temperature errors and pressure errors increase by the factor

$$F = (\text{full-scale value of smallest measuring range}) / (\text{full-scale value of smallest measuring range} - \text{start-of-scale value})$$

. "F" should not exceed a value of "7" here. In general, we recommend that the smallest span not be increased by more than approximately 30%.

### Span setpoint

Check the span setpoint using function 22.

The displayed setpoint must agree with the calibration gas value. If this is not the case, make them agree using function 22.

Select the leading measuring range for "Total calibration".

The setpoints must lie as far from the zero point as possible (at least 60% of the respective full-scale value). Provide the corresponding calibration gases for the span calibration. Enter the setpoints under function 22.

### Changing measuring ranges

The linearized characteristic for the largest measuring range (according to the rating plate) is stored in memory. If the largest measuring range (function 41) is changed, this full-scale value must not be exceeded.

The measuring range must not fall below the smallest measuring range (according to the rating plate), since in this case the noise and temperature influences on the measured value will increase relative to the measuring range, which would impair repeatability and worsen the drift behavior.

## Operation

### 7.1 User interface and operating modes

#### Measured value display and operator panel

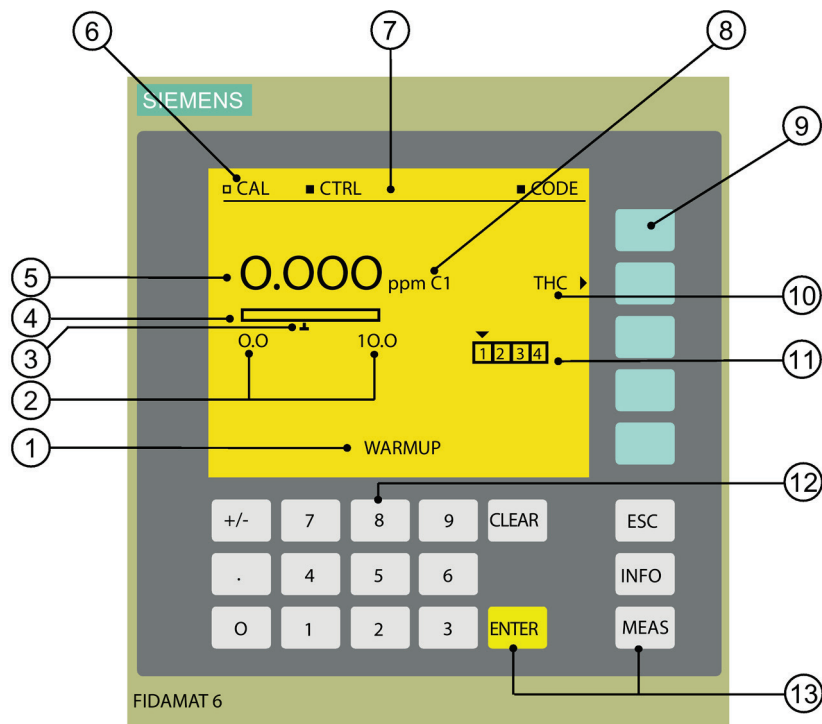

- |  |  |
|--|--|
| 1 Bottom line (display of current operating state)               | 8 Display of unit of measurement   |
| 2 Measuring range with start-of-scale value and full-scale value | 9 Buttons with varying function (soft keys)                                |
| 3 Limit marking  | 10 Display of measured component   |
| 4 Analog measured value display (bar display)                    | 11 Display of activated measuring ranges with marking of the current range |
| 5 Measured value   | 12 Numeric keypad  |
| 6 Status message   | 13 Function keypad   |
| 7 Status line  |  |

Figure 7-1 Measured value display and operator panel

## Meaning of operator keys

Table 7- 1 Meaning of operator keys

Key	Meaning/function
CLEAR	Clears a number entry you have started
ENTER	Every number entered (except fast activation of a function) must be confirmed with [ENTER].
ESC	Jumps back one step in the operating structure. Changes are accepted without a prompt.
INFO	Information about current menu / current function
MEAS	Jump back from every position in the operating structure to the "Decoded display mode" (you may be asked to confirm the entered data first). Pressing the [MEAS] key again changes the operating mode to "Coded display mode", i.e. another change to "Operator control mode" requires the entry of the corresponding code.
Softkey	Varying meaning; possible here are: <ul style="list-style-type: none"> <li>• Submenu selection / function selection</li> <li>• Selection of a subfunction</li> </ul>

## Editing inputs

The values in the menu displays in this section are meant as examples.

An active input field is shown with colons (e.g.: 10:) as a limiter. The cursor flashes under the number to be entered.

By pressing the [ENTER] button, you finish your input and the value is stored. If there are several input fields on one function screen, the cursor positions itself at the next input field at the same time.

---

### Note

Confirm every entered value, even the last of several values in a function, before exiting the function with [ENTER]!

---

With the [CLEAR] key, you can clear a number that you have begun to enter. The cursor then jumps back to the first position of the input field.

Graphic symbols

- = activated (ON state; also in status message in the status line)
- = deactivated (OFF state; also in status message in the status line)
- ▶ = access a submenu/subfunction
- = initiate a function/subfunction (e.g. Start calibration...)

## Device operating modes

Table 7- 2 Operating modes of the FIDAMAT 6

Mode	Properties	Remarks
Coded display mode	<ul style="list-style-type: none"> <li>Measured value display is shown</li> <li>Protected submenus can only be reached by entering a code</li> <li>The current operating state of the device (except for "Measuring") is displayed in the bottom line</li> <li>Function control not active</li> </ul>	The device only supplies reliable measured values in this mode, provided it is in "Measuring" operating state. You reach this mode from operator control mode by pressing the [MEAS] key twice.
Decoded display mode	<ul style="list-style-type: none"> <li>Measured value display is shown</li> <li>The submenus protected by the entered code are accessible</li> <li>The current operating state of the device (except for "Measuring") is displayed in the bottom line</li> <li>Function control active</li> <li>Measured value can be influenced</li> </ul>	You reach this mode from operator control mode by pressing the [MEAS] key once and confirming or discarding the entries that were made.
Operator control mode	<ul style="list-style-type: none"> <li>Menu or function is displayed</li> <li>Settings and inputs can be made</li> <li>Function control active</li> <li>Measured value can be influenced</li> </ul>	You reach this mode from "Coded display mode" by entering the code of the corresponding operation level. You configure/calibrate the device in this mode.

Schematic diagram of the operating sequence with operating modes

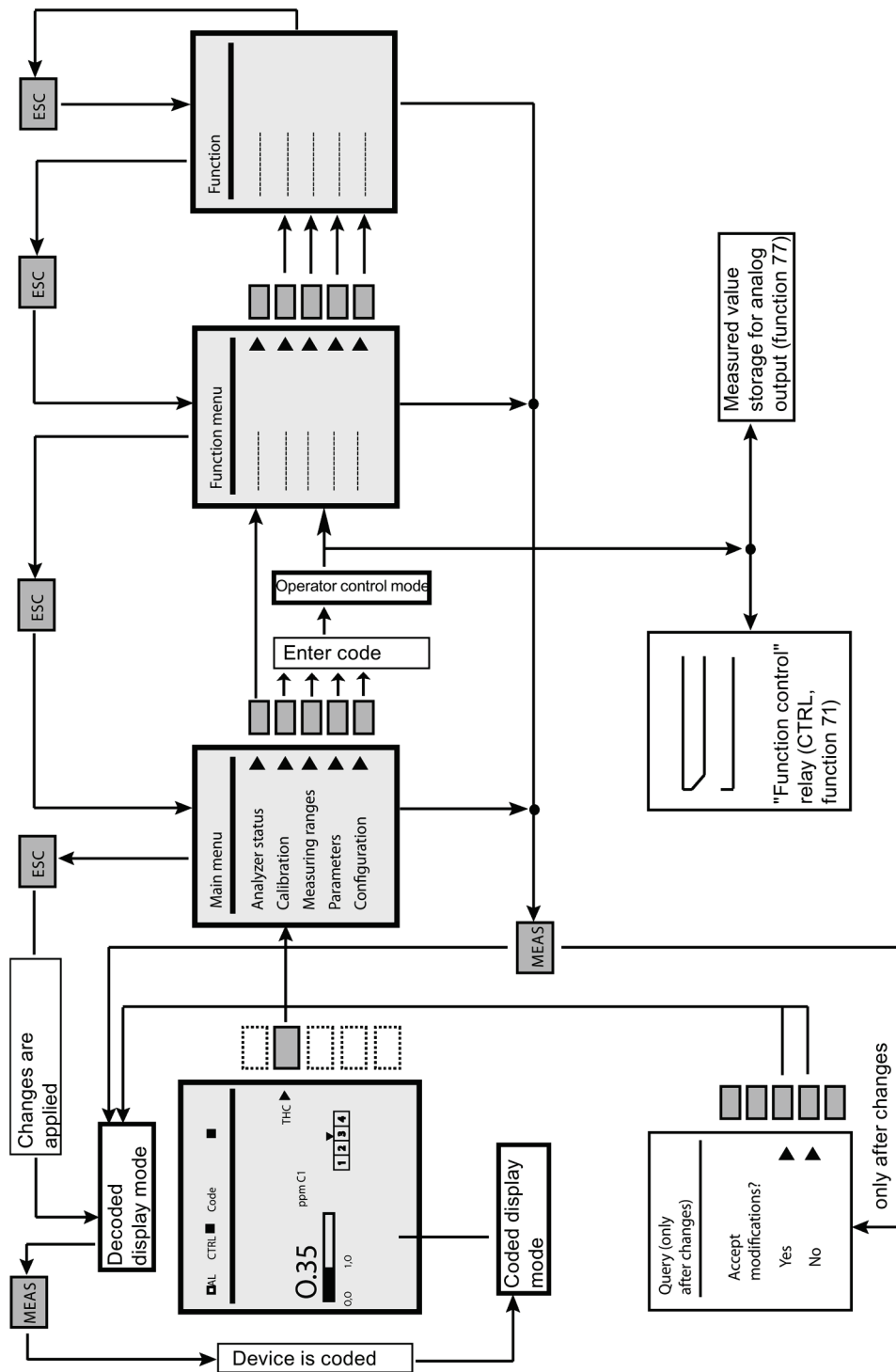

Figure 7-2 Operating sequence

## 7.2 Measured value display

The display shown below that appears in the display in the "Coded display mode" and "Decoded display mode" operating modes is referred to in the following as the "Measured value display".

---

### Note

#### Device operating state

In the "Measured value display", the current operating state of the device can be read in the bottom line. The "Measured value display" is not an operating state and not an operating mode, but is simply a display. It must not be confused with the "Measuring" operating state (also "Measuring state") of the device!

---

### Access to the main menu

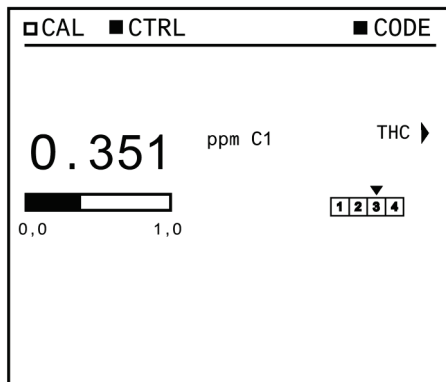

Figure 7-3 Measured value display

On the right side of the measured value display is the measured component with an arrow pointing to the right (►). A softkey is assigned to this component.

Press this softkey to call the main menu.

## 7.3 Entering a submenu

The main menu consists of five submenus.

Main menu	THC
Analyzer status	▶
Calibration	▶
Measuring ranges	▶
Parameters	▶
Configuration	▶

Figure 7-4 Main menu

Some of these are protected against unauthorized access by various level codes.

Menu	Code level
Analyzer status	Not coded
Calibration	Code level 1
Measuring ranges	Code level 1
Parameters	Code level 1
Configuration	Code level 2

The code of level 1 is preset to "111" in the factory, and the code of level 2 is preset to "222".

### Entering a submenu

If you select a submenu by pressing the associated softkey, the code of the corresponding operation level is queried once (exception: the submenu "Analyzer status" is freely accessible; selecting this does not change the operating mode).

Decoding level 2 also decodes level 1.

By entering a corresponding code, the device switches to the operator control mode, whereby the functional check is activated.

The functional check "CTRL" (shown in the status line of the measured value display) is always activated by the device when an intervention endangers correct measurement, e.g. when the code is entered. If you have configured a corresponding relay using function 71 with "Functional check", an extra signal is sent out via the relay contact together with the decoding. This relay contact then signals every functional check activation, e.g. even the warm-up phases and calibration states of the device.

Decoding also activates the measured value memory, providing you have parameterized it using function 77. The coding status of the device can be read in the status line of the measured value display as a symbol "■ CODE" for "coded" or "□ CODE" for "decoded".



## 7.4 Jump back to coded/decoded display mode

With the [MEAS] key, you return from "Operator control mode" back to "Decoded display mode". Any input started is canceled.

Before the return, the following query appears:

Return to measuring	THC
Accept modifications?	
	YES ●
	NO ●

Figure 7-5 Query before return

- Press "YES" to transfer the changes to the work memory of the parameter memory or "NO" to discard the changes. The device then changes to "Decoded display mode".
- Press [ESC] to return to the last function screen. Changes are accepted here without a query.

### Coding the device

After the return to "Decoded display mode" with [ESC] or [MEAS], you put the device back into "Coded display mode" by pressing [MEAS] again. Only now is function control deactivated again.

## 7.5 Fast function selection

In order to directly access the desired function when operating frequently from the "Coded display mode", a "Power user operation" was created. This allows you to directly access the desired function by entering the function number. This allows you to skip menu levels. However, the functions can only be directly called from "Coded display mode". For fast function selection, proceed as follows:

1. Enter the number of the desired function using the number keys.
2. Press the softkey of the component with the arrow ►. If the desired function is protected by a code, you will be asked to enter the code.

## 7.6 Calibration

### 7.6.1 General information on calibration

---

#### Note

Calibration is only possible when the device is in "Measuring" operating state.

---

#### Zero point

You calibrate the zero point with function 20. The device displays both the setpoint and actual value.

#### Single / total range calibration

Single calibration means that you calibrate each measuring range with a separate calibration gas. This is recommended when the switching ratio of the spans is greater than 1:10.

With the total range calibration, you only calibrate the leading measuring range (function 22). The other ranges are "calibrated along" via the switching ratio.

The total range calibration is activated or deactivated using function 23.

Select function 21 and perform the desired calibration. Note that this function can only be selected if AUTOCAL (function 24) is deactivated. If the total range calibration was activated previously, all measuring ranges are then calibrated.

If you have selected single calibration (total range calibration deactivated), repeat the calibration operation for each measuring range individually with the corresponding calibration gases. (a calibration gas must be entered for every measuring range under function 22!)

#### Zero and span calibrations

Connect the device to zero gas or calibration gas. In doing so, observe the prescribed input pressures.

Calibrate the zero point using function 20, and the span using function 21.

### 7.6.2 Calibration examples

#### a) Detection of hydrocarbons in air

Measuring range: 0 – 20 ppm C1

Calibration gas: 15 ppm methane in air

Zero gas: Synthetic air (free of hydrocarbons)

Step	Procedure	Function	Input	Comment
1	Select start-of-scale and full-scale values of measuring range	41	0 – 20 ppm	
2	Enter setpoints for zero and span	22	Zero point: 0 ppm Span: 15 ppm	Take inlet pressures into account (see "Technical specifications (Page 167)")
3	Calibrate the zero point	20		
4	Calibrating the span	21		

### b) Detection of hydrocarbons in air

Measuring range: 0 – 50 ppm C3

Calibration gas: 90 ppm methane in nitrogen (6.0)

Zero gas: Nitrogen (free of hydrocarbons)

Step	Procedure	Function	Input	Comment
1	Select start-of-scale and full-scale values of measuring range	41	0 – 50 ppm	
2	Enter setpoints for zero and span	22	Zero point: 0 ppm C3 Span: 30 ppm C3	90 ppm C1 yields 30 ppm C3
3	Calibrate the zero point	20		
4	Calibrating the span	21		

#### **Note**

The operator input options of the named functions are described in detail in "Functions".



# Functions

## 8.1 Overview of operating functions

The device functions are listed in the following overview. This list corresponds to software version V1.3.6.

Table 8- 1 Overview of operator control functions

Submenu	Function	Name of function
Analyzer status	1	Analyzer configuration
	2	Diagnostic values
	3	Logbook
	4	Display meas. ranges
Calibration (code 1)	20	Zero calibration
	21	Span calibration
	22	Setpoints for zero/ span
	23	Calibration settings (single/total range calibration)
	24	AUTOCAL/-check (only with option board)
	25	Drift values
Measuring ranges (code 1)	40	Range selection
	41	Define meas. ranges
Parameters (code 1)	50	El. time constants
	51	Limits
	52	On/off configuration
	53	Status messages
	54	G. signal display
	55	Select digits
	56	LCD contrast
	57	Ignite flame
	58	Date/Time
	59	Sample selection
	60	Setup logbook
	61	Int. valves
	62	Adjust external pressure (FIDAMAT 6-G only)
	Configuration (code 2)	70
71		Relay assignment
72		Binary inputs
73		ELAN configuration
74		Reset
75		Save data, load

8.2 Analyzer status

Submenu	Function	Name of function
	76	Suppress fault
	77	Analog output memory
	78	Calib. tolerance
	79	Change codes
	80	Analyzer test
	81	Select language
	83	Interfer. correct.
	85	Switch valves
	86	Lin. temp. comp.
	87	Error On/Off
	90	PROFIBUS config. (only with option board)
	91	Start-up state (operating states)
	92	Pressure values
	93	Dimension
	99	Factory settings

See also

Fast function selection (Page 71)

## 8.2 Analyzer status

### 8.2.1 Analyzer status submenu

Analyzer status	THC
1 Analyzer configuration	▶
2 Diagnostic values	▶
3 Logbook	▶
4 Display meas. ranges	▶

Figure 8-1 Analyzer status submenu

The analyzer status functions are freely accessible. For this reason, there is no code query and no change of operating mode.

The analyzer status submenu offers you various functions for displaying device parameters and stored data.

## 8.2.2 Analyzer configuration (function 1)

After this function is selected, the following device manufacturing data appear:

### Motherboard

- Firmware number:  
Article number of the motherboard software stored in the EPROM
- Article number:  
Information on device ordering data
- Production number:  
Date of manufacture and device serial number
- Object version:  
Device hardware version
- Software version/date:  
Version of motherboard software, date, version of boot software of motherboard

### Adapter board

- Firmware number:  
Article number of the adapter board software stored in the EPROM
- Software status:  
Version of the adapter board software
- Boot software status:  
Version of the adapter board boot software

## 8.2.3 Diagnostic values (function 2)

The most important diagnostic values may be called using function 2. They may allow conclusions to be drawn for evaluation of errors or setting work.

### 8.2.4 Logbook (function 3)

In the logbook, all errors which led to a maintenance request (W) or a fault (S) are listed.

The limit alarm (LIM) and functional check (CTRL) are also registered. However, these do not trigger a maintenance request or fault message.

The logbook contains a max. of eight pages, with four messages per page. It works according to the rotating buffer principle, i.e. when all eight pages (all 32 locations) are occupied, the oldest message is overwritten.

You can delete or block logbook entries (function 60), but you can also switch them off individually (function 87).

---

#### Note

If an error occurs whose error message is switched off with function 87, there is no reaction at any configured interface. This applies both to the ELAN interface and to the analog output and the relay output.

---

In case of servicing, function 110 (diagnostics service) is to be observed as well. However, this function is only accessible to service engineers.

#### See also

Logbook settings (function 60) (Page 103)

Error on/off (function 87) (Page 127)

List of maintenance requests (Page 139)

List of faults (Page 140)

### 8.2.5 Display measuring ranges (function 4)

The measuring ranges defined using function 41 are listed here. However, you cannot carry out any changes in this function.



## 8.3 Calibration

### 8.3.1 Calibration submenu

Calibration	THC
20 Zero calibration	▶
21 Span calibration	▶
22 Setpoints for zero/ span	▶
23 Calibration settings	▶
...continue	▶

Figure 8-2 Calibration submenu

You can calibrate the device using the functions available in this menu. Press the fifth softkey "...continue" to access further functions.

This menu is protected by the code of code level 1.

The FIDAMAT 6 offers the option of a manual or automatic calibration (function 24). The latter is only possible with an optional board which contains an additional eight binary outputs and eight relay outputs.

The setpoints for the zero and span calibrations are entered using function 22.

Calibrate using calibration gases which are very close to the sample gas in composition and concentration. If the task is to measure hydrocarbons in nitrogen, you should also use hydrocarbons in nitrogen as the calibration gas. If you use, for example, propane in synthetic air instead, the measurement is falsified by the response factor of methane with respect to propane and by the oxygen error.

### 8.3.2 Zero calibration (function 20)

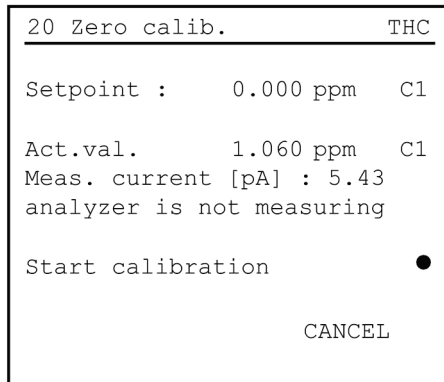

Figure 8-3 Zero calibration

---

#### Note

For calibration of device version 7MB2421-xDA1x-1AAx-Y37, only oxygen-free gases are permitted to be used.

---

In order to calibrate the zero point, the device must be in "Measuring" operating state. If this is not the case, calibration is not possible. The display will show the message *"analyzer is not measuring"*.

The zero calibration is performed simultaneously for all measuring ranges, even when the span of the measuring ranges is calibrated individually.

After call of function 20, the internal zero gas valve is opened.

Only initiate calibration when the measured value (actual value) has stabilized after feeding the zero gas. Otherwise, the calibration may be imprecise.

If there is a lot of noise, increase the time constant before calibrating (function 50).

#### See also

Electric time constants (function 50) (Page 94)

### 8.3.3 Span calibration (function 21)

After call up of function 21, the internal calibration gas valve is opened.

---

#### Note

For calibration of device version 7MB2421-xDA1x-1AAx-Y37, only oxygen-free gases are permitted to be used.

---

### Single calibration ("Measuring" operating state required)

21 Span. Calib.	THC
Calibrate MR 1	▶
Calibrate MR 2	▶
Calibrate MR 3	▶
Calibrate MR 4	▶

Figure 8-4 Performing a single calibration

Single calibration is only possible if the *"Total range calibration"* subfunction has been deactivated in function 23.

In the display, the same number of measuring ranges appear as you have specified with function 41. The above function display is an example of a single calibration of four measuring ranges.

If, for example, you want to calibrate measuring range 3, press the corresponding softkey.

The setpoint and current actual value of the selected measuring range now appear in the display:

21 Cal. sp. MR 3	THC
Setpoint : 100.000 ppm	C1
Act.val. : 98.090 ppm	C1
Meas. current [pA] : 305 analyzer is not measuring	
Start calibration	●
CANCEL	

Figure 8-5 Calibrating the measuring range

When the actual value has stabilized, you can initiate the calibration by pressing the fourth softkey. The actual value is now made to agree with the setpoint.

If you make a mistake during the calibration (e.g. wrong calibration gas), reload the original calibration by pressing the "CANCEL" softkey.

### Total range calibration ("Measuring" operating state required)

A total range calibration is only possible if the *"Total range calibration"* subfunction is activated under function 23.

With a total range calibration, you calibrate all measuring ranges together. Specify the "leading" measuring range under function 22. We recommend using the largest measuring range for this.

The setpoint and current actual value of the "leading" measuring range appear in the display.

When the actual value has stabilized, you can initiate the calibration by pressing the fourth softkey. The actual value is now made to agree with the setpoint.

If you make a mistake during the calibration (e.g. wrong calibration gas), reload the original calibration by pressing the "CANCEL" softkey.

**See also**

Setting the setpoints (function 22) (Page 82)

Total / single calibration (function 23) (Page 83)

Define measuring ranges (function 41) (Page 93)

**8.3.4 Setting the setpoints (function 22)**

22 Setpoints total	THC
Setpoint for zero : 5.40: ppm C1	
Setpoint for MR 1 8.50 ppm C1	<input type="checkbox"/>
Setpoint for MR 2 12.50 ppm C1	<input type="checkbox"/>
Setpoint for MR 3 600.50 ppm C1	<input type="checkbox"/>
Setpoint for MR 4 8245.50 ppm C1	<input checked="" type="checkbox"/>

Figure 8-6 Setting the setpoints

The function screen shows the setpoint input with total calibration. The fourth measuring range is chosen here as the leading measuring range.

With single calibration, there is no choice for the leading measuring range.

### 8.3.5 Total / single calibration (function 23)

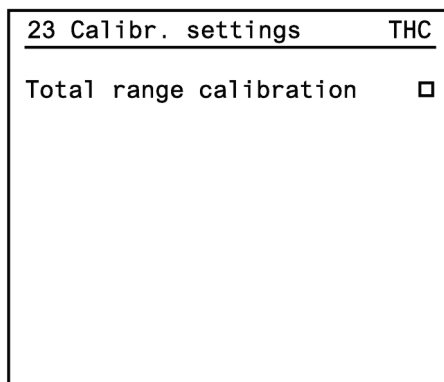

Figure 8-7 Select calibration method

With this function, select between the total and single calibration of the measuring ranges.

Total calibration means that you adjust one "leading measuring range" and all other measuring ranges are calibrated using the switching ratio.

If the total calibration, as shown on the function screen, is not activated, you must calibrate every range individually.

### 8.3.6 AUTOCAL (function 24)

---

#### Note

You can only make use of automatic calibration (AUTOCAL) if your device contains additional electronics (option board). If it does not, a corresponding message will appear on the display when the AUTOCAL function is called.

Automatic calibration can only be started when the device is in "Measuring" operating state!

---

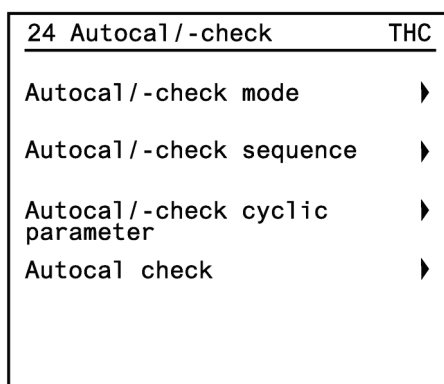

Figure 8-8 AUTOCAL function

**Note**

The settings for "AUTOCAL/-check..." (subfunctions 1 to 3) are valid both for AUTOCAL (automatic calibration) and for AUTOCAL check (automatic check for adherence to the set calibration tolerances, without calibration).

The settings for "AUTOCAL Check" (4th subfunction) only refer to the check of the calibration tolerances without calibration.

**AUTOCAL/-check mode**

Autocal/-check mode	THC
Autocal/-check on/off	<input type="checkbox"/>
Start autocal/-check cyclically	<input type="checkbox"/>
Start autocal/-check via binary input	<input type="checkbox"/>
Trigger autocal once	
Abort autocal	

Figure 8-9 AUTOCAL/-check mode

With this subfunction, you configure various AUTOCAL operating modes.

***"Autocal/-check on/off":***

In "Autocal off" state (display:"□"), the settings of "Start autocal cyclically (parameter)" and "Start autocal via binary input" have no effect on the device. "Trigger Autocal once" cannot be selected. The cycle time continues to run. No automatic calibration is initiated, however.

***"Start autocal/-check cyclically":***

You can activate AUTOCAL for a regularly recurring cycle if you have set "Time from Autocal to Autocal (cycle time)" using subfunction "Autocal/-check cyclic parameter" beforehand.

The AUTOCAL Check is used only for checking the calibrations. As with Autocal, the device executes the sequence configured in subfunction "Autocal/Check sequence". In contrast to AUTOCAL, no new calibrations are initiated; only the deviations are checked with respect to selectable calibration tolerances.

***"Start autocal/-check via binary input":***

If you have previously configured a binary input with function 72, you can initiate AUTOCAL via a binary input.

***"Trigger Autocal once":***

In "Autocal on" state, you can start an AUTOCAL sequence at any time with the "Trigger Autocal once" softkey, providing the device is in "Measuring" operating state. A sequence

initiated in this way has no effect on the time cycle of an AUTOCAL, i.e. the cycle time continues to run independent of this.

After initiating, the dot disappears until the process is finished.

***"Abort autocal":***

A running automatic calibration operation can be exited at any time using the *"Abort autocal"* softkey. With this, all calibration data determined up to that point are discarded and the calibration data valid before AUTOCAL was started continues to be used (zero and span).

The abort has no effect on the time cycle. All valid calibration operations are retained.

**AUTOCAL sequence**

Acal/-check sequen.	THC
1. Zero gas 1 :1.0: min	●
2. Cal. gas 1 1.1 min	●
3. Cal. gas 2 1.2 min	●
4. Cal. gas 3 1.3 min	●
...continue ▶	

Figure 8-10 AUTOCAL/-check sequence

With this subfunction, you combine several calibration phases to form one AUTOCAL sequence.

You can arrange the automatic calibration as you wish. It is possible to "compose" a sequence of up to twelve different phases.

Besides the supply of one zero gas and up to four calibration gases per component, you can also program purging with sample gas and a sample gas intermediate operation as well as a signaling contact. The signaling contact is available if you previously assigned it to a relay output using function 71.

**Sample gas intermediate operation**

Sample gas intermediate operation can be necessary if the system may only leave measuring mode for a certain time. If the required purge times are greater in total than the permissible downtime, measuring mode must be returned to between calibrations.

**Signaling contact**

Use the signaling contact, for example, to initiate an automatic calibration operation of a second device or to signal the beginning or end of an AUTOCAL.

**Relay outputs**

If you have defined relay outputs for the sample gas, zero gas, calibration gases and/or measuring/calibration (function 71), these are used to actuate the corresponding external

solenoid valves. The same also applies to the "AUTOCAL" signaling contact. This is closed for approximately 1 s when the command is executed.

**Example:**

You want to program the following sequence:

1. Zero gas calibration, after 15 minutes of purging with zero gas
2. Calibration with calibration gas 1, after 10 minutes of purging with calibration gas
3. Purging with sample gas: 8 minutes
4. Sample gas intermediate operation: 30 minutes
5. Calibration with calibration gas 2, after 8 minutes of purging
6. Calibration with calibration gas 3, after 8 minutes of purging
7. Calibration with calibration gas 4, after 10 minutes of purging
8. Purging with sample gas: 8 minutes
9. Short-term signaling contact in order to be able to start AUTOCAL on another device or channel.

The specified AUTOCAL sequence is shown in the following function screens.

Acal / -check sequen.	THC
1. Zero gas 1 :15.0: min	●
2. Cal. gas 1 10.0 min	●
3. Purge SG 8.0 min	●
4. SG i/m.op. 30.0 min	●
...continue ▶	

Figure 8-11 Example AUTOCAL sequence

Acal / -check sequen.	THC
5. Cal.gas 2 : 8.0: min	●
6. Cal.gas 3 8.0 min	●
7. Cal.gas 4 10.0 min	●
8. Purge SG 8.0 min	●
...continue ▶	

Figure 8-12 Example AUTOCAL sequence



Acal/-check sequen.	THC
9. Sig. cont.: :: :: : min ●	
10. : :: :: : min ●	
11. : :: :: : min ●	
12. : :: :: : min ●	
	...continue ▶

Figure 8-13 Example AUTOCAL sequence

**List for the AUTOCAL sequence:**

---

**Note**

Zero gas 2 is not used with FIDAMAT 6.

---

**Autocal/-check cyclic parameter**

Acal/-check cycle	THC
Time from autocal to auto- cal (cycletime) : 2: h	
Time up to next autocal cycle 15 min	
Carry out span calibration for each 1. cycle	

Figure 8-14 AUTOCAL/-check cyclic parameter

With this subfunction, you configure various time constants for activating a cyclically recurring AUTOCAL.

***"Time from autocal to autocal (cycle time)":***

Any setting between 1 and 720 (hours) is accepted by the device.

***"Time up to next autocal cycle" (after the time of setting):***

If you enter "0" here and AUTOCAL is activated with *"Autocal on/off"*, the device immediately begins the AUTOCAL sequence.

If AUTOCAL is deactivated, the device only starts an AUTOCAL sequence if AUTOCAL is activated within one minute after entering "0". If not, the total time between two AUTOCAL cycles elapses starting from the input of "0".

**Note**

The clock inside the device also runs when AUTOCAL is deactivated! It starts the first time the device is switched on and must be set to the current time using function 58.

***"Carry out span calibration for each xth cycle":***

Here you set the number of cycles after which a calibration with the calibration gas is to be carried out.

If you would like to save on calibration gas, for example, and not calibrate the span along with every zero calibration, enter in the line *"Carry out scan calibration gas for each xth: cycle"* an integer value > 1.

**Note**

As long as AUTOCAL is activated (Autocal ■), access to functions 20 and 21 is blocked. If you activate these functions anyway, a corresponding message appears on the display.

**Settings for AUTOCAL check**

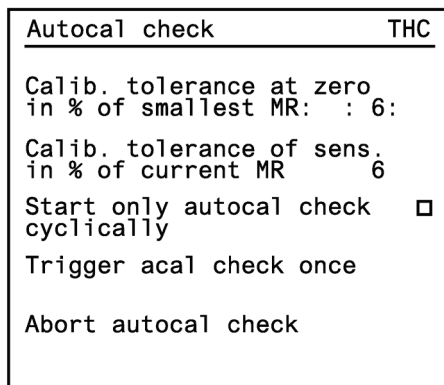

Figure 8-15 Autocal check

In the *"Autocal check"* subfunction, enter the desired calibration tolerances that are to be checked by AUTOCAL check. Using functions 71 and 72, you can also select the relay output or binary input for "AUTOCAL Check".

When a calibration limit is exceeded, the maintenance request W10 is set, and also, if configured, the relay "Acal Chk Dif".

Both will be reset again after an error-free AUTOCAL Check. W10 is retained in the logbook.

***"Start only Autocal check cyclically":***

If this function is activated, the device executes an AUTOCAL Check when Start AUTOCAL cyclically is set. In other words, only the adherence to the calibration tolerances is checked, and no calibration is performed.

**Sequence:**

1. Start of AUTOCAL check:
  - Using the *"Trigger autocal once"* softkey in the *"Acal/-check sequence"* subfunction
  - Via binary input
  - Via cycle
2. The device executes a sequence as configured in the *"Autocal/-check sequence"* subfunction.

**See also**

Relay outputs (function 71) (Page 107)

Binary inputs (function 72) (Page 109)

Drift values (function 25) (Page 89)

**8.3.7 Drift values (function 25)**

This function shows deviations occurring for the calibrations (and AUTOCAL as well ) (actual value - setpoint) as a sum parameter. All rated zero point and sensitivity calibrations of each range are calculated here for the selected measured component. Every new deviation is added to the existing drift value.

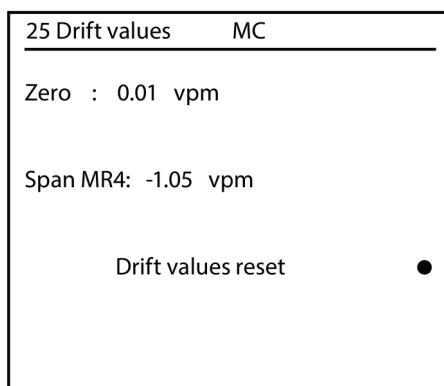

Figure 8-16 Drift values

The display of the drift values for the sensitivity calibration depends on the setting of the calibration method. If total calibration is selected here, only the selected measuring range for the sensitivity calibration is displayed. For single calibration, all measuring ranges can be individually adjusted and can therefore have different drift values, which are shown separately.

The drift values can reset to 0.0 with the 'Reset drift values' instruction. When you reboot the device all measuring ranges have 0.0 as the drift value.

## 8.4 Measuring ranges

### 8.4.1 Measuring ranges submenu

Meas. ranges	THC
40 Range selection	▶
41 Define meas. ranges	▶

Figure 8-17 Measuring ranges submenu

The measuring ranges menu contains all functions you need for selecting and setting the measuring ranges.

This menu is protected by the code of code level 1.

### 8.4.2 Select measuring ranges (function 40)

You can select a fixed measuring range or switch to an automatic measuring range switchover. All selection options are subject to mutual interlocking.

Automatic measuring range switchover is only possible under the following conditions:

- At least two measuring ranges must be available. A measuring range is regarded as available when the following is true: Measuring range start value  $\neq$  measuring range end value
- The measuring spans must become larger
- The measuring ranges must "border on" each other or overlap

### Measuring range types

This yields the permissible measuring range types shown in the figure below:

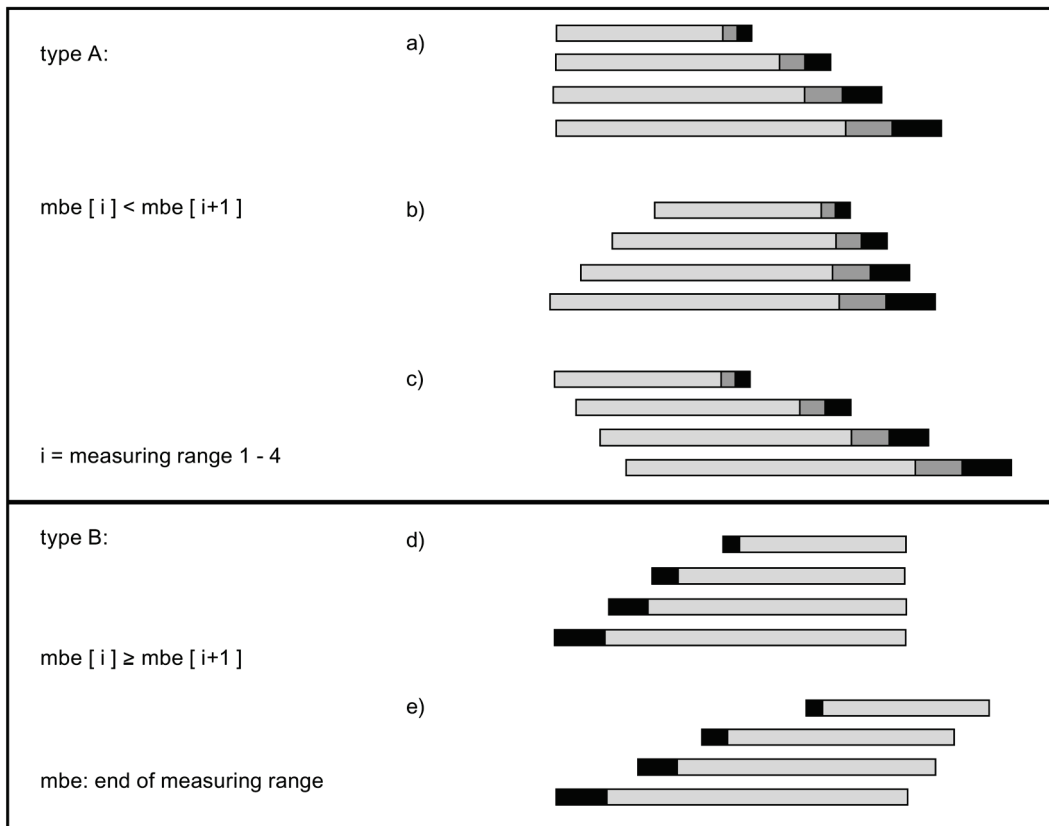
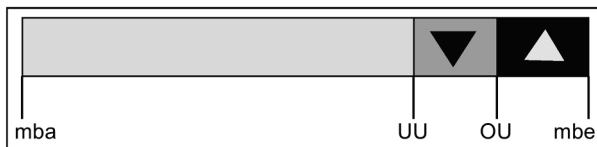

Figure 8-18 Measuring range types

Two measuring range types are distinguished:

#### Type A:

The measuring range end value must be smaller than the measuring range end value following it. The top measuring range limit thus becomes higher with every measuring range.



- mba Start of measuring range
- mbe End of measuring range
- UU Lower switchover point: Select smaller measuring range
- OU Upper switchover point: Select larger measuring range

Figure 8-19 Measuring range type A

The following applies to the measuring range switchover:

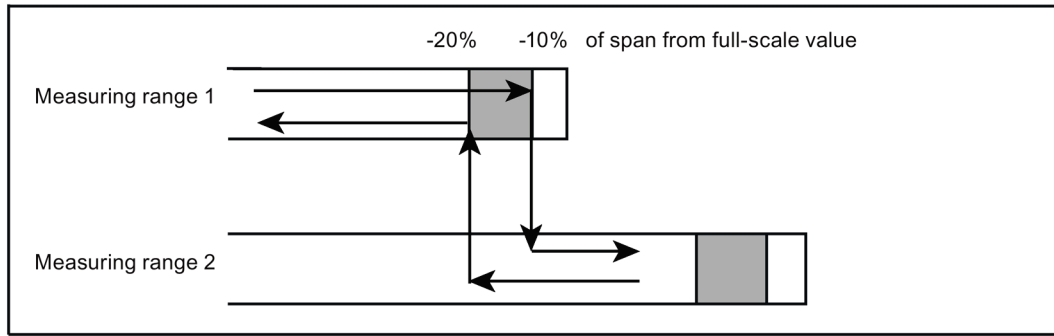
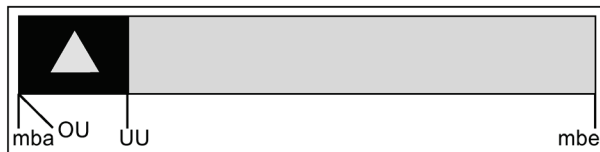

Figure 8-20 Measuring range switchover type A

When the upper switchover point (OU) is exceeded, the next larger measuring range available is selected. When the lower switchover point (UU) of the next smaller measuring range available is fallen below, this measuring range is selected. The UU lies at 80 % (HystA) of the measuring range. The OU lies at 90% (HystE) of the measuring range.

**Type B:**

The measuring range end value must be larger than or equal to the measuring range end value following it. Since the measuring spans must also become larger, the measuring range start values of the following measuring ranges are always smaller.



- mba Start of measuring range
- mbe End of measuring range
- UU Lower switchover point: Select smaller measuring range
- OU Upper switchover point: Select larger measuring range

Figure 8-21 Measuring range type B

The following applies to the measuring range switchover:

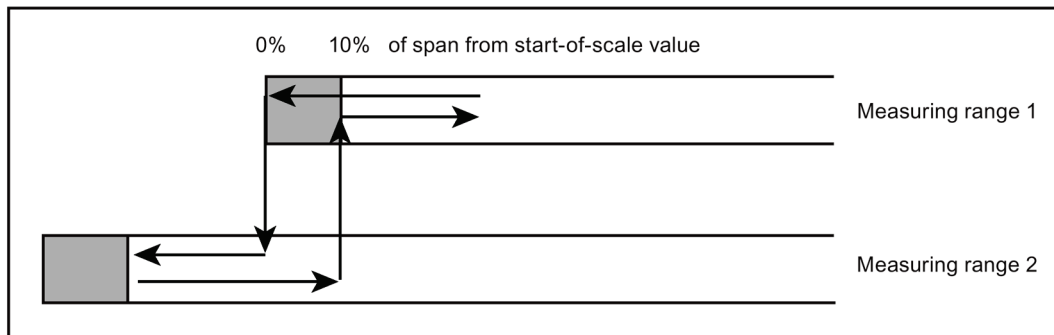

Figure 8-22 Measuring range switchover type B

When the upper switchover point (OU) is fallen below, the next larger measuring range available is selected. If the lower switchover point (UU) of the next smaller measuring range available is exceeded, this measuring range is selected.

The UU lies at 10% (100% - HystE) of the measuring range. The OU lies at the start of the measuring range (mba).

### 8.4.3 Define measuring ranges (function 41)

41 Define range			THC
MR start No.	end	value	
1:	0.000:	10.0	ppm C1
2	0.000	50.0	ppm C1
3	0.000	80.0	ppm C1
4	0.000	100.0	ppm C1

Figure 8-23 Define measuring ranges

You can define a maximum of four measuring ranges whose start-of-scale values are allocated to the bottom value (0/ 2/ 4 mA) and whose full-scale values are allocated to the top value (20 mA) of the analog output.

If the message "Measuring ranges not plausible!" appears, this means that autoranging is not possible.

If the start-of-scale and full-scale values are "0", the measuring range is deactivated.

## 8.5 Parameters

### 8.5.1 Parameters submenu

Parameters	THC
50 El. time constants	▶
51 Limits	▶
52 On-/off configuration	▶
53 Status messages	▶
...continue	▶

Figure 8-24 Parameters submenu

The parameters menu contains all functions which are required for parameterizing the device.

You can branch to further parameter functions by pressing the fifth softkey, "...continue".

This menu is protected by the code of code level 1.

### 8.5.2 Electric time constants (function 50)

50 Electr. time con	THC
Effective bandwidth in % of smallest MR : : 6.0: %	
Time constant within bandwidth ti= 10.0 s	
Time constant outside bandwidth ta= 1.0 s	
Actual measured value: 0.00 ppm C1	

Figure 8-25 Electric time constants

With this function, you set various time constants in order to reduce noise. The noise reduction is approximately equivalent to a low-pass filter with the corresponding time constant. The display delay is given as the 90% time.

The time constant "ti" acts within an parameterizable effective interval which is defined in % of the smallest span. It attenuates small changes in the measurement (e.g. noise) on the one



hand, but becomes ineffective immediately when the measured value exceeds the effective interval. In this case, the outer time constant "ta" attenuates the measured value.

You can parameterize values up to 100% for the effective interval, and values up to 300 s for the time constants "ti" and "ta". By cleverly combining these three parameters, you can achieve a low display delay (90% time) despite high noise suppression.

The effect on the set attenuation parameters can be observed in the bottom line. The "live" measured value is displayed here.

### 8.5.3 Limits (function 51)

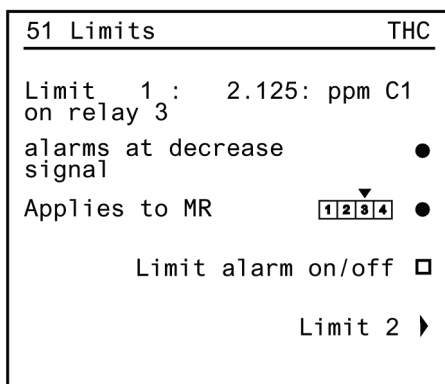

Figure 8-26 Limits

The device monitors up to four limits for every measured component, and these limits can be assigned to the measuring ranges as desired. Any relay can be assigned to each limit with function 71.

You can only configure positive limits up to 100%.

***"Alarms at decrease signal":***

Here you select whether a limit alarm is to be switched if the entered limit is exceeded or fallen below.

***"Applies to MR...":***

Here, you assign the limit to the desired measuring ranges by pressing the third softkey several times. When you do so, pointers move over the measuring range numbers and indicate the measuring ranges within which the limit monitoring is to be active. In the above example, this is measuring range 3.

***"Limit alarm on/off":***

The limit monitoring of each single limit can be switched off individually using function 52.

The response of a limit relay is registered in the logbook (function 3). As soon as the cause of the limit alarm has been eliminated, the limit relay is reset automatically.

You can change to the next limit using the fifth softkey ("*Limit...*").

**See also**

- Logbook (function 3) (Page 78)
- On/off functions (function 52) (Page 96)
- Relay outputs (function 71) (Page 107)

**8.5.4 On/off functions (function 52)**

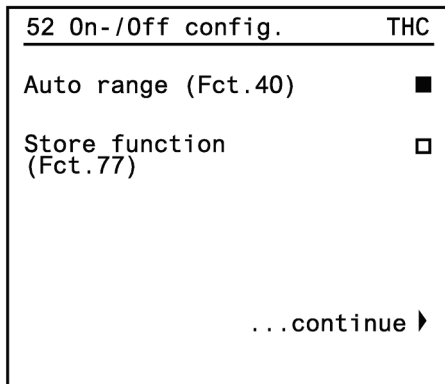

Figure 8-27 On/off configuration

**Note**

Device-specific on/off functions can only be called using the first component ("THC").

With this function, you can easily switch other functions on and off, such as the ones listed in the above function screen.

Thanks to this simplified operation, these functions do not have the longer paths through various menus. For better orientation, the function numbers have also been specified.

Activated functions are marked by "■", deactivated ones by "□". Using the fifth softkey ("...continue"), jump to the next function screen with further functions.

Function 52 is used to switch the following functions on and off:

Table 8- 2 Functions switched on/off by function 52

Designation	Function	Remarks
Total range calibration	23	
Automatic measuring range switchover	40	
Limit alarm on/off 1	51	
Limit alarm on/off 2	51	
Limit alarm on/off 3	51	
Limit alarm on/off 4	51	

Designation	Function	Remarks
Suppress negative measured values for display	55	
Lock logbook	60	
Suppress negative measured values	70	
Fault/ Maint. A/ CTRL/ NAMUR	72	
Analog output memory	77	
Signal tolerance violation	78	
Temperature post-compensation of the zero point	86	
Temperature post-compensation of the span	86	
Automatic setting of AUTOCAL for PROFIBUS (firmware version 1.3.5 or higher)	None	<p>When a PROFIBUS option card is installed, the following operating modes of AUTOCAL (function 24) are set when the device is re-started:</p> <ul style="list-style-type: none"> <li>• 'AUTOCAL/Check' ON;</li> <li>• 'Start cyclically' OFF</li> <li>• "Start via binary input" OFF</li> </ul>

Besides the functions listed in this section, function 52 can also be used to activate other service functions. These are restricted to service engineers and are only visible when the service code is entered (code level 3).

### 8.5.5 Status messages (function 53)

53 Status messages	THC
Display automat. calibration [CAL]	■
Display stored value [ST0]	□
Display limits [LIM]	□
Display autorange [AR]	□
Display control function [CTRL]	■

Figure 8-28 Status messages

With this function, you can configure the display of status messages in the status line of the measured value display. You can display a maximum of three different status messages. The message CODE ■/□ provides information on the current operating mode ("Coded display mode"/"Decoded display mode") and is therefore always displayed.

The device activates the function control (softkey 5 in the function display) when it determines that the measured value was influenced.

This is the case:

- During the warm-up phase
- After entry of the code (i.e. change to "Operator control mode")
- When remote control via the interface (ELAN, PROFIBUS) is used
- During automatic calibration (Autocal) or remote calibration

**Note**

**Control function ("CTRL")**

When the function control is active, the measured value can be false!

As long as you are in code level 1 or 2, thus in "Operator control mode", the function control is active. If you have configured the analog output with "Store on" under function 77, this remains in fault current state until you remove it because any code level has to be exited.

Table 8- 3 Status messages

Status	What appears in the display depends on functions 52 and 53			
	Function 53 "□"	Function 52 "□" Function 53 "■"	Function 52 "■" Function 53 "■"	
Calibration: CAL	None	CAL	□ CAL	■ CAL; calibration running (also in Autocal)
Stored value: STO	None	STO	□ STO	■ STO; analog output is stored (see function 77)
Limit: LIM	None	LIM	□ LIM	■ LIM; limit has been violated (see function 51)
Autorange AR	None	AR	□ AR	■ AR; measuring range switching (actively possible), see function 40
Control function: CTRL	None	□ CTRL or ■ CTRL (function control cannot be switched off using function 52)	□ CTRL	■ CTRL; device is in the "Warm-up phase" operating state or in "Operator control mode" or calibration is in progress or a remote control via the interface (ELAN, PROFIBUS) is taking place

If an error occurs during operation, the message "Maintenance request", "Fault" or "Measurement protection" appears in the status line, depending on the severity of the error. This message is alternately displayed with the status messages.

In addition, when communication is over the ELAN interface, the message "Remote" is displayed – also alternating – with display of the device status.

**See also**

Select measuring ranges (function 40) (Page 90)

Limits (function 51) (Page 95)

Analog output memory (function 77) (Page 119)

## 8.5.6 Graphical representation of measured values (function 54)

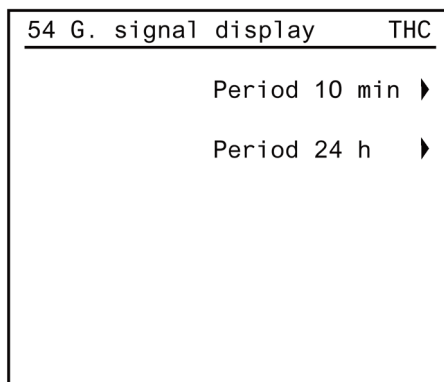

Figure 8-29 Graphical representation of measured values

With this function, you can follow the trend of the measured values for the last ten minutes or 24 hours on the display.

Select the desired time period with softkey 1 or 2.

The device now graphs the measured value vs. time:

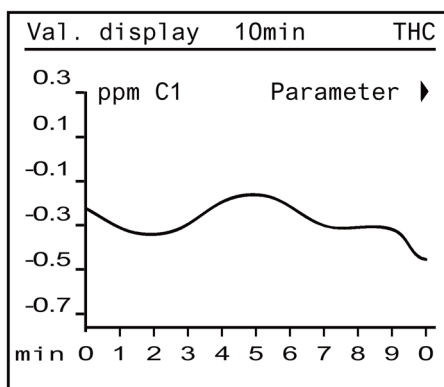

Figure 8-30 Measured value trend

The most recent measured value is on the time axis at the left at  $t = 0$ .

Select softkey 1 "Parameters".

Here, assign a certain measuring range to the measured value axis:



## 8.5.8 LCD contrast (function 56)

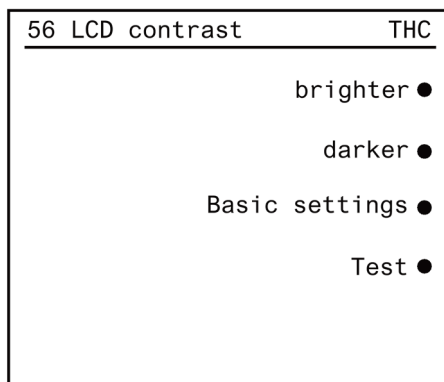

Figure 8-33 Setting the LCD contrast

With this function, you can make the display contrast brighter or darker.

If the contrast is misadjusted, you can reestablish the factory settings using the third softkey "Basic settings".

With the fourth softkey "Test", you can carry out an LCD test. Various test screens are then displayed in succession.

From "Coded/decoded display mode", you can reestablish the basic setting by entering [8][8][8][8] [ENTER].

## 8.5.9 Ignite flame (function 57)

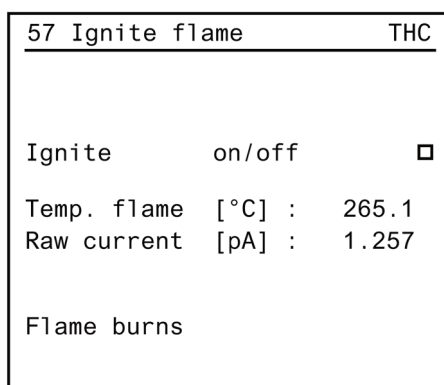

Figure 8-34 Ignite flame

In order to put the FID into operation, the flame must be ignited. This normally happens automatically once the "Warm-up phase" has been completed successfully.

For checking/testing purposes, you can also ignite the flame manually using function 57.

Press the second softkey to activate ("■") or deactivate ("□") the ignition. The display shows the temperature of the flame and the measured current.

When the flame is burning, "Flame burns" appears on the display. If it goes out, this message disappears.

### 8.5.10 Date/time (function 58)

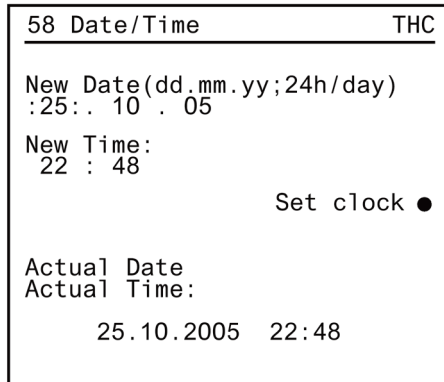

Figure 8-35 Setting the date/time

With this function, you can set the date and time.

The cursor is already located at the first place of the date display. Enter the new settings in the order: day, month, year. By pressing [ENTER], jump to the next input field. Set the time in the same way (hours, minutes).

The system clock of the device is not buffered against mains failures (not a real-time clock).

---

#### Note

When the device is switched off, the clock stops and is not updated.

---

The settings are especially important for troubleshooting. Errors which are always stored in the logbook (function 60) can be allocated more easily with the help of the date and time.

Press the third softkey "Set clock" in order to accept the set data. These then appear at the bottom edge of the display.

#### See also

Logbook (function 3) (Page 78)

Logbook settings (function 60) (Page 103)



### 8.5.11 Measuring point switching (function 59)

59 Sample selection		THC
M.pt. 1	Rel. 2 :	45: min
M.pt. 2	Rel. 1	20 min
M.pt. 3	Rel. 4	12 min
M.pt. 4	Rel. 3	8 min
M.pt. 5	Rel. 6	23 min
M.pt. 6	Rel. 5	6 min
M.p. switching on/off <input type="checkbox"/>		

Figure 8-36 Sample selection

With this function, you assign a maximum of six measuring points and an automatic cyclic switchover.

The precondition for this is that you have used function 71 "Relay outputs" beforehand to configure the measuring point relay that then controls the corresponding solenoid valves.

Every measuring point relay is also assigned a time period, which you enter in the respective input field. Values between 0 and 60 (minutes) are possible for this input.

Press the fifth softkey to activate/deactivate the sample point switchover.

You can assign a signal relay to each measuring point relay. This allows a measuring point identification separate from the measuring point relay. You also use function 71 to configure the signal relay.

#### See also

Relay outputs (function 71) (Page 107)

### 8.5.12 Logbook settings (function 60)

60 Setup logbook		THC
clear logbook ●		
lock logbook <input type="checkbox"/>		

Figure 8-37 Configuring the logbook

With this function, you clear or lock logbook entries.

From the "Coded/decoded display mode", you can also delete logbook entries with the button sequence [5][5][5][5] [ENTER].

Status messages such as maintenance requests or faults cannot be suppressed by "Lock logbook". They still appear, despite the locked logbook.

**See also**

Logbook (function 3) (Page 78)

**8.5.13 Internal valves (function 61)**

61 Int. valves	THC
hydrogen	on/off <input checked="" type="checkbox"/>
combustion air	on/off <input type="checkbox"/>
zero gas	on/off <input type="checkbox"/>
calibration gas	on/off <input type="checkbox"/>
	...cont. ▶

Figure 8-38 Controlling internal valves

With this function, you switch the internal valves for controlling the gases. Press the respective softkey to activate ("■") or deactivate ("□") the valves.

The internal valves block or open the gas flow for combustion gas, combustion air, zero gas, calibration gas and sample gas.

**8.5.14 Set external pressure (function 62)**

---

**Note**

This function is valid only for FIDAMAT 6-G.

---

62 Adjust ext. pres	THC
zero gas            on/off	■
calibration gas   on/off	□
sample gas        on/off	□
air :              0 hPa	

Figure 8-39 Adjust external pressure

With function 62, you put the device into the "Measuring" operating state by activating the sample gas, zero gas or calibration gas.

Also, you can test the pressures of these gases and adjust them if necessary.

## 8.6 Configuration

### 8.6.1 Configuration submenu

Configuration	THC
70 Analog outputs	▶
71 Relay outputs	▶
72 Binary inputs	▶
73 ELAN configuration	▶
...continue	▶

Figure 8-40 Configuration submenu

All functions of this menu are only accessible via the code of level 2.

This menu contains all functions required for configuring the device.

Press the fifth softkey ("...continue") to branch to further configuration functions.

### 8.6.2 Analog output (function 70)

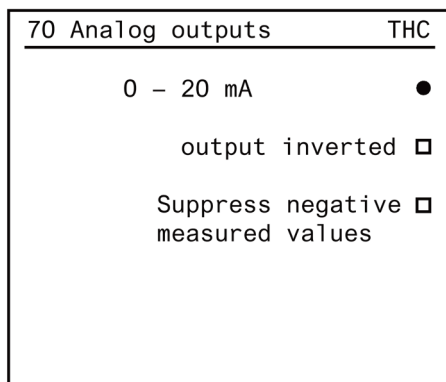

Figure 8-41 Configuring the analog output

You configure the analog output with this function.

With softkey 1 you define the lower value of the measuring range. The following settings (see also table "Configurations of the analog output") are possible:

- 0 – 20 mA
- 2 – 20 mA
- 4 – 20 mA
- NAMUR/4 – 20 mA (with limiting at 3.8 mA).

You invert the analog output with softkey 2: e.g. 0 to 100 ppm THC  $\equiv$  0 to 20 mA or 0 to 100 ppm THC  $\equiv$  20 to 0 mA.

You suppress negative measured values with softkey 3. If negative values have an unfavorable effect on further processing, the negative measured values at the analog output can be limited to 0 (or 2/ 4/ 3.8 (NAMUR)) mA when this function is activated. The display continues to show the actual measured value.

Table 8- 4 Configurations of the analog output

Defined analog output / mA	Measuring range limiting in normal operation		Measuring range limiting in case of fault / CTRL	
	Start-of-scale value / mA	Full-scale value / mA	Start-of-scale value / mA	Full-scale value / mA
0 – 20	-1	21	0	21
2 – 20	1	21	2	21
4 – 20	2	21	4	21
4 – 20 (NAMUR)	3.8	20.5	3	21.5

**Note**

If the electronics is defective, it is possible for the analog output to become stuck at approx. - 1 mA or approx. +24 mA.

### 8.6.3 Relay outputs (function 71)

71 Relay outputs	THC
R 1 Sample pt.6	●
R 1 Sample pt.2	●
R 1 Sample pt.1	●
R 1 Limit 4	●
...cont. ▶	

Figure 8-42 Assigning the relays

There are six freely configurable relays included in the standard equipment whose switchable output contacts (max. 24 V/1 A) can be used for signaling, actuating valves, etc.

If these six relays are insufficient, you can add eight more relays through additional electronics (option board).

With this function, you assign one of the functions listed in the table "Relay outputs (possible functions)" to each relay, whereby you may only assign each function once. In other words, for example, "Fault" may not be assigned to two relays at the same time.

The connection assignments for the individual relays in the zero-current state can be found in the terminal diagram "Motherboard pin assignment". The relays are preset at delivery.

Press the fifth softkey ("...cont."), to access the next function screen, thus branching to further relays.

Table 8- 5 Relay assignment (possible functions)

Function	Relay is passive when	Relay conducts current	Note
Not assigned			Relay is permanently passive (zero current)
Fault	Fault		Also shown in status line of measured value display
Maintenance request	Maintenance request		Also shown in status line of measured value display
Calibration		Calibration running	For identification purposes

Function	Relay is passive when	Relay conducts current	Note
Measuring range 1 to 4		Measuring range 1 to 4 On	Measuring range identification
Limit 1 to 4	Limit 1 (to 4) triggered		Limit alarm on/off
Control function (CTRL)	Function control active (e.g. on change to operator control mode; in the warm-up phase, when AUTOCAL or calibration is running)	Function control deactivated	Signal when: <ul style="list-style-type: none"> <li>• Device is decoded</li> <li>• Warm-up phase (max. 2 h)</li> <li>• Calibration running (AUTOCAL)</li> <li>• Remote control via interface (ELAN, PROFIBUS)</li> </ul>
Sample gas		Supply of sample gas	Actuation of valves
Zero gas 1		Supply of zero gas	Actuation of valves
Calibration gas 1 to 4		Supply of calibration gas	Actuation of valves
Measuring point 1 to 6		Measuring point 1 to 6 selected	For taking a gas sample via solenoid valves at various sample points
Signal for measuring point 1 to 6		Measuring point 1 to 6 selected	For identifying the sample point (runs in parallel with measuring point)
Signaling contact		When signaling, the relay is briefly energized.	e.g. in the case of AUTOCAL: Control of a second device
Gas path heating		Heating ready for operation	For identification purposes
Autocal check		Autocal difference too large (function 24)	
Combustion gas		Combustion gas valve is open	Actuation of valves
Combustion air		Combustion air valve is open	Actuation of valves
Operator input prompt		Operator intervention required	Gas connection faulty; W5 (combustion air/combustion gas) present; Device in PAUSE / STANDBY

## 8.6.4 Binary inputs (function 72)

### Functions of binary inputs

72 Binary inputs	THC
Fault/Maint.r/CTRL NAMUR	☐
Binary inputs define	▶

Figure 8-43 Binary inputs function

Six floating binary inputs are included in the standard equipment ("0" = 0 V [0 to 4.5 V]; "1" = 24 V [13 to 33 V]).

If these six inputs are insufficient, you can add eight more binary inputs through supplementary electronics (option board).

If you activate the "NAMUR" ("■") operating mode with softkey 1, the binary inputs behave as marked with "N" in table "Control functions of the binary inputs".

If you deactivate the "NAMUR" ("☐") operating mode, the binary inputs behave compatibly with the software releases of the older version V 4.3.0 (marked with "X" in table "Control functions of the binary inputs").

Select softkey 2. The following function screen appears on the display.

72 Binary inputs	THC
B 1 Aca1 check	●
B 2 Fault 1	●
B 3 Maint.req. 1	●
B 4 Vacant	●
...cont.	▶

Figure 8-44 Defining binary inputs

Here you assign one of the control functions listed below to each input as you like, whereby every function may only be assigned once.

The connection assignments for the individual inputs can be found in the section "Electrical connection".

No binary input has been preassigned in the factory.

Press the fifth softkey ("...cont."), to access the next function screen, thus branching to further binary inputs.

**Note**

**Save changes**

Make sure you save every change in the configuration of the binary inputs in the user data memory using function 75! If you neglect to do this, there is a danger that a previous (unwanted) configuration will be loaded by "Load user data" (function 75).

Table 8- 6 Control functions of the binary inputs

Function	Control voltage needed			Remark/effect
	0 V	24 V	24 V (min. 1 s)	
Not assigned				No effect when input is set
Fault 1 to 7	N	X		e.g. due to: <ul style="list-style-type: none"> <li>• Signal from a gas preparation system:                             <ul style="list-style-type: none"> <li>– Condensate overflow</li> <li>– Gas cooler defective</li> </ul> </li> <li>• Fault message from interfering gas analyzer</li> </ul>
Maintenance request 1 to 7	N	X		
Acknowledge			N, X	Setting the input deletes all logbook entries. However, if the cause of a fault or maintenance request has not been eliminated, the corresponding message reappears in the logbook.
Function control 1 to 4	N	X		Relay must be configured for function control under function 71 if, for example, the function is to be controlled by a second device.
AUTOCAL			N, X	Note: Effective control only possible in "Measuring" operating state! Autocal must be configured (function 24)
Measuring range 1 to 4			N, X	When the input is set, the corresponding measuring range is switched to.
Zero gas			N, X	Note: Effective control only possible in "Measuring" operating state! Relay must be configured for zero gas. After the input is set, the device changes from "Measuring" to "Calibrating" operating state. See also "Example of binary inputs"



Function	Control voltage needed			Remark/effect
	0 V	24 V	24 V (min. 1 s)	
Calibration gas			N, X	Note: Effective control only possible in "Measuring" operating state!  Relay must be configured for calibration gas. After the input is set, the device changes from "Measuring" to "Calibrating" operating state. See also "Example of binary inputs"
Sample gas			N, X	Note: Effective control only possible in "Measuring" and "Calibrating" operating states! For FIDAMAT 6-G, also from "Standby", whereby the device requires a short time to build up pressure.  Relay must be configured for sample gas. Before the sample gas valve opens, the other valves are closed. The device then switches to the "Measuring" operating state, and all other states (e.g. "Calibrating") are exited.
Zero Calib.			N, X	A calibration starts when the input is set. See also "Example of binary inputs"
Span Calib.				
Autorange			N, X	Activate "Automatic measuring range switching"
Autocal check			N, X	Note: Effective control only possible in "Measuring" operating state!  Start Autocal check (function 24)
Measurement protection		N, X		It is possible to define a binary input "Measurement protection" that has the following effect:  If the device is in "Measuring" operating state (function control deactivated), it remains in this state, i.e.: <ul style="list-style-type: none"> <li>• The device can no longer be decoded.</li> <li>• The device can no longer be set to "Remote".</li> </ul> The message "Measurement protection activated" appears in the status line of the measured value display.
Standby			N, X	Sets the "Standby" start-up state (Function 91). This allows the sample gas pump to be switched off. Only valid for FIDAMAT 6-E (with pump) firmware version V1.3.5 or higher.

### See also

Binary inputs (function 72) (Page 109)

### Example for zero calibration

Calibrate the zero point via the binary inputs by taking the following steps.

**Presettings**

1. Assign one binary input with the "Zero gas" function.
2. Assign one binary input with the "Zero Calib." function for zero calibration.
3. Exit function 72 and accept the changes.

**Perform calibration**

**Note**

The binary input assigned with "Zero gas" can only be effectively controlled in "Measuring" operating state! Therefore, make sure that the device is in "Measuring" state.

1. Now set the "Zero gas" binary input with the necessary voltage for at least 1 second.  
 The device opens the zero gas valve and closes the sample gas valve (sample gas valve only available in FIDAMAT 6-G).  
 At the same time, the device switches to "Calibrating" operating state (shown in the measured value display with "■ CAL") and activates the "Function control" (shown in the measured value display with "■ CTRL").
2. Wait until the measured value has stabilized.
3. Now set the "Zero Calib." binary input with the necessary voltage for at least 1 second.  
 The device calibrates the zero point. Afterwards, it leaves the "Calibrating" operating state ("□ CAL") and deactivates the "Function control" ("□ CTRL"). It is now back in "Measuring" state. Calibration is complete.

The following figure illustrates the sequence:

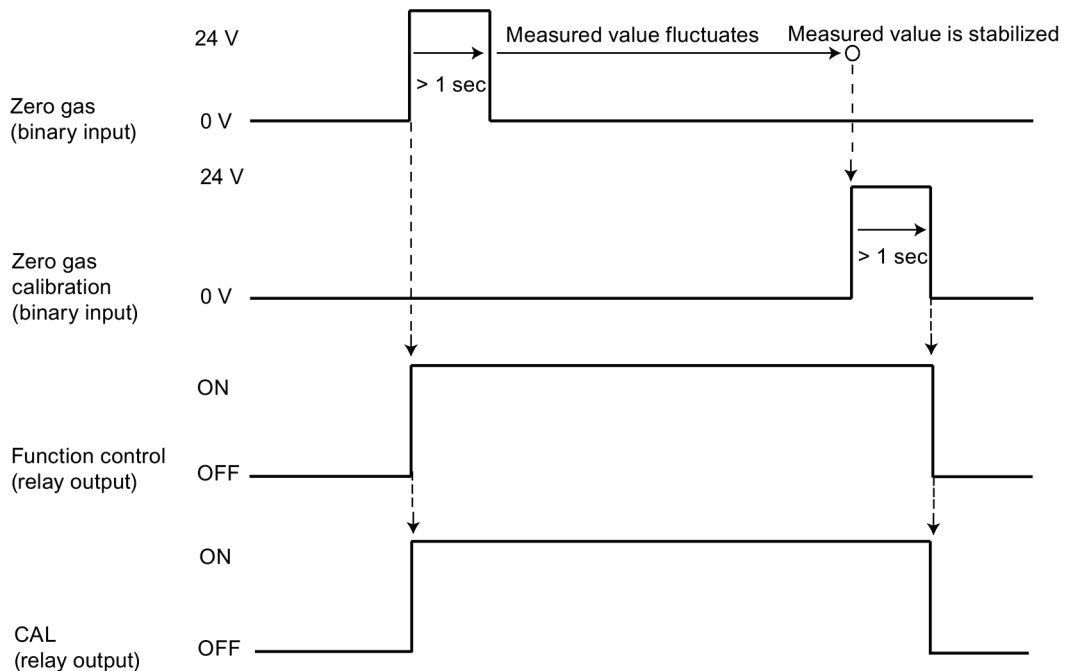

Figure 8-45 Calibration of the zero point via binary inputs

## Example of scan calibration

Calibrate the span via the binary inputs by taking the following steps.

### Presettings

1. Choose the measuring range to be calibrated. This is dependent on the setting of the "Total range calibration" in function 23:
  - Total range calibration activated:  
Select the desired measuring range in function 22 as the leading measuring range.
  - Total range calibration deactivated:  
Set the desired measuring range as the current measuring range. This is done using one of the following:
    - Menu 40
    - Binary input with the "Measuring range x" function in function 72.
2. Configure a relay output with "Calibration gas x" for controlling the corresponding calibration gas valve (function 71). The number of this calibration gas must correspond to the number of the measuring range to be calibrated.
3. Assign a binary input with the "Calibration gas" function (function 72).
4. Assign a binary input with the "Span Calib." function for calibrating the span.
5. Assign a binary input with the measuring range in which the device should return to after completing the calibration ("Measuring range 1/2/3/4" or "Aurorange" for automatic measuring range switching). This step is necessary because the device otherwise remains in the measuring range being calibrated.
6. Exit function 72 and accept the changes.

### Perform calibration

1. Set the "Measuring range x" binary input with the necessary voltage for at least 1 second.  
The device selects the corresponding measuring range.

---

#### Note

The binary input assigned with "Calibration gas" can only be effectively controlled in "Measuring" operating state! Therefore, make sure that the device is in "Measuring" state.

---

2. Now set the "Calibration gas" binary input with the necessary voltage for at least 1 second.

**For FIDAMAT 6-E:** The corresponding relay is energized by the binary input and now opens the calibration gas valve.

**For FIDAMAT 6-G:** The corresponding relay is energized by the binary input and now opens the calibration gas valve and closes the sample gas valve.

At the same time, the device switches over to "Calibrating" state (shown in the measured value display with "■ CAL") and activates the "Function control" (shown in the measured value display with "■ CTRL").

3. Wait until the measured value has stabilized.

- Now set the "Span Calib." binary input with the necessary voltage for at least 1 second.

The device calibrates the corresponding measuring range. At the same time, the device leaves the "Calibrating" state ("□ CAL") and deactivates the "Function control" ("□ CTRL"). It is now back in "Measuring" state. Calibration is complete.

- Now set the binary input that you assigned to the desired measuring range after calibration for at least 1 second.

The device is now in the desired measuring range. You can continue with measurement.

The following figure illustrates the sequence:

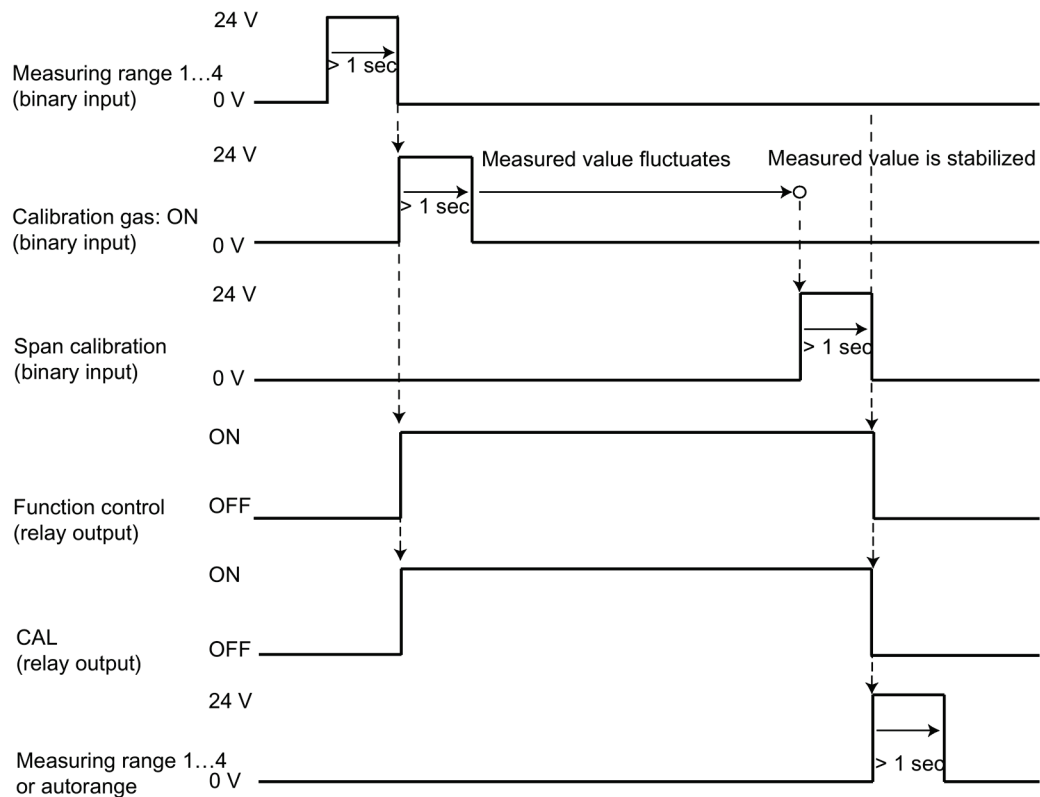

Figure 8-46 Calibration of the span via binary inputs

**See also**

- Select measuring ranges (function 40) (Page 90)
- Relay outputs (function 71) (Page 107)
- Binary inputs (function 72) (Page 109)

## 8.6.5 ELAN configuration (function 73)

73 ELAN Config.	THC
Channel address:	01 ●
Measured value telegram:	on ●
ELAN tag : FIDA6	

Figure 8-47 Configuring ELAN

With this function, you set the parameters for an ELAN network.

- *Channel address:*  
Set the channel address here. Addresses from one to twelve can be set. In an ELAN network, each address may only be used once.
- *Measured value telegrams on/off:*  
Here you activate or deactivate the independent cyclic sending of measured values every 500 ms.

---

### Note

#### Independent sending of measured values

If you have set up your own communication control system, this option offers a simple way of checking an ELAN telegram. In order to avoid unnecessarily loading of the device and the ELAN network, however, the function should only be switched on as needed!

---

- *ELAN tag:*  
Display of the tag assigned for this device in the ELAN network.

Further ELAN details can be found in the ELAN interface description:

- (C79000-B5200-C176 German)
- (C79000-B5276-C176 English)

### See also

ELAN interface cable (Page 51)

### 8.6.6 Reset (function 74)

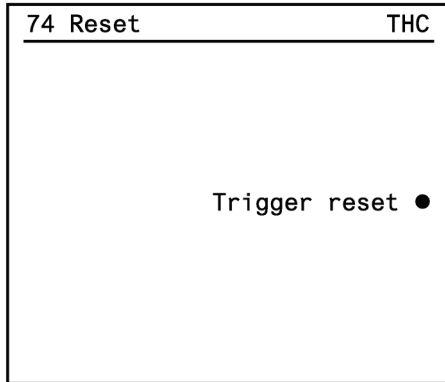

Figure 8-48 Carrying out a reset

With this function, you can carry out a warm restart.

After calling this function, the device switches to the "Warm-up phase", which activates the functional check at the same time. The device is only completely ready for operation again after successfully running through this phase.

### 8.6.7 Save / load data (function 75)

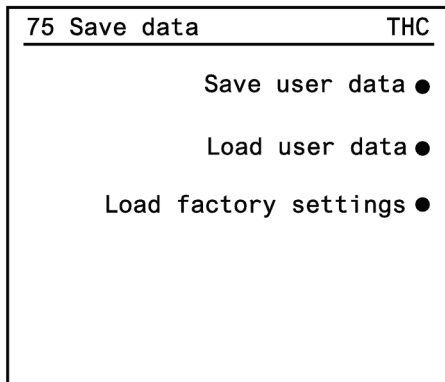

Figure 8-49 User data memory

You configure the user data memory with this function.

Press the softkey 1 "Save user data" e.g. after the system has been successfully commissioned. All individual settings are then saved.

Press the softkey 2 "Load user data", to load the last user data saved.

These functions are important when the device is undergoing repairs or maintenance work, or, for example, if new parameter settings are to be tried out.

Press softkey 3 to restore the factory settings.

A confirmation prompt is set up in this function. In order to actually load the respective data in the memory, you must confirm with "yes". If you select "no", this is canceled.

**Note**

Make sure you save every change in the configuration of the relay outputs in the user data memory using function 75!

If you neglect to do this, there is a danger that a previous (unwanted) configuration will be loaded by "Load user data" (function 75).

The following figure shows an overview of the interaction between the various memory modules.

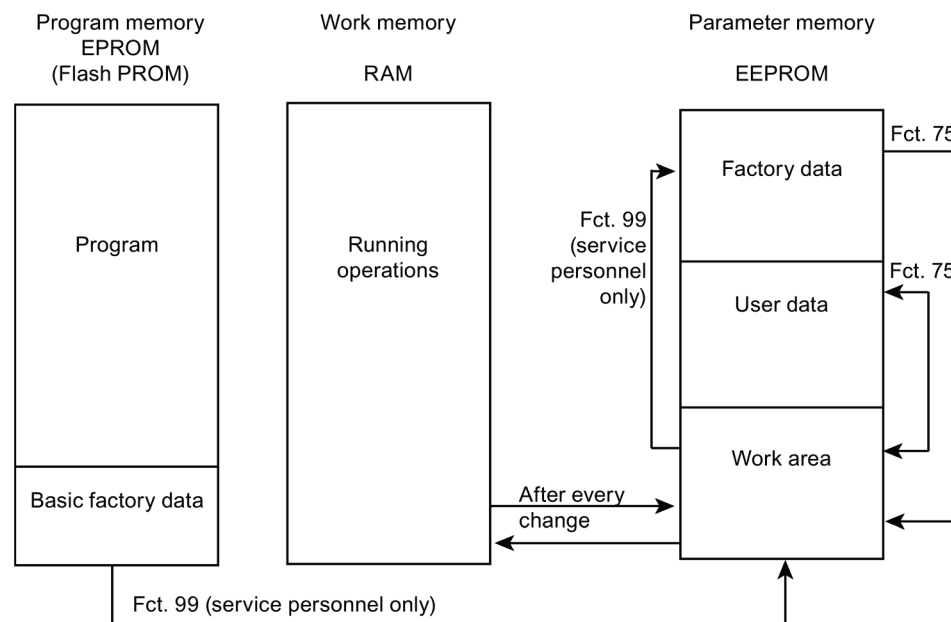

Figure 8-50 Memory modules

### 8.6.8 Suppression of short-term noise signals (function 76)

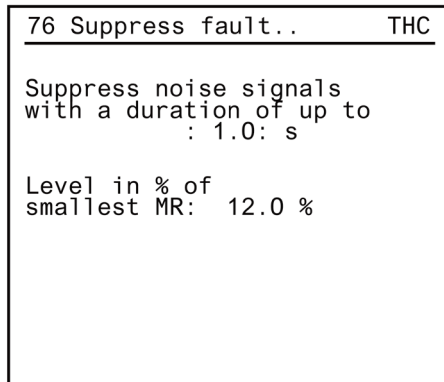

Figure 8-51 Suppression of noise signals

With function 76, you can eliminate undesired spikes which exceed a settable threshold.

Spikes are caused by electromagnetic interferences or occasional mechanical shocks.

These faults can be suppressed by entering a "blanking time" of 0 to 5 s. The entered time has the effect that the last measured value before the spike occurred is displayed so that the measured result is not influenced.

Times can be entered in steps of 0.1 s.

Under "*Level in % of smallest MR*", enter the threshold value in % of the smallest measuring range above which the noise signals are to be suppressed.

If the smallest measuring range is 1 to 100 ppm, for example, the threshold is exactly 12 ppm when 12 % is set.

In the configuration shown, the device therefore suppresses noise signals which are at least 12 ppm above the last measured value and last for  $\leq 1.0$  s.

---

**Note**

If a change in concentration directly follows a fault, this may be displayed after a delay.

When this function is activated, the settings of function 50 ("Electric time constants") must be taken into account, since these are executed first.

---

**See also**

Electric time constants (function 50) (Page 94)

Relay outputs (function 71) (Page 107)



## 8.6.9 Analog output memory (function 77)

77 Store	THC
analog out.to meas.value	<input checked="" type="checkbox"/>
analog out.to 0/2/4 mA	<input type="checkbox"/>
analog out.to 21 mA	<input type="checkbox"/>
Store on/off	<input type="checkbox"/>

Figure 8-52 Setting the analog output

With this function, you set which current is output at the analog output when a fault occurs or when the functional check "CTRL" is activated (e.g. during calibration).

With softkey 5, you can activate () or deactivate () the entire function.

Switch softkey 1 to active () in order to output the last measured value at the analog output.

Switch softkey 2 to active () in order to output 0/2 or 4 mA.

Switch softkey 3 to active () in order to output 21 mA.

## 8.6.10 Calibration tolerances (function 78)

### Setting the calibration tolerances

78 Calib. tolerance	THC
Calib. tolerance at zero in % of smallest MR: :10:	
Calib. tolerance at span in % of current MR: 10	
Signal tolerance violation	<input type="checkbox"/>

Figure 8-53 Setting the calibration tolerances

With this function, you define the calibration tolerances.

With softkey 3 "Signal tolerance violation", you activate or deactivate the tolerance monitoring.

If you previously configured a relay output to "Maintenance request" using function 71, the device outputs changes of the zero point or span with respect to the last calibration as "Maintenance request".

**Note**

In order to be able to use this function, "Total range calibration" (function 23) must be activated.

With "Calibration tolerance at zero...", you define the maximum deviation in relation to the smallest span in %.

With "Calibration tolerance at span ...", you define the maximum deviation in relation to the current span in %.

The calibration tolerance, which can be set from 0 to 99%, refers to the span of the smallest measuring range in the case of the zero point and to the span of the measuring range in which the total range calibration is being performed (marked with "■" in function 22) in the case of the span.

**Example**

Measuring range 1	5 to 100 ppm THC
Measuring range 2	20 to 200 ppm THC
Smallest span	95 ppm THC
Leading measuring range in which calibration is being performed	Measuring range 2
Response threshold for zero point	95 ppm THC x 10% = 9.5 ppm THC
Response threshold for span	180 ppm THC x 10% = 18 ppm THC

If the zero/span deviates by more than the configured value compared to the last calibration, and if "Signal tolerance violation" is activated, the corresponding relay signals a maintenance request.

**See also**

Total / single calibration (function 23) (Page 83)

### 8.6.11 Change codes (function 79)

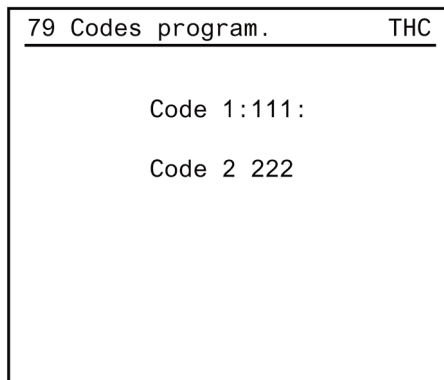

Figure 8-54 Change codes

With this function, you replace the factory-set codes ("111" for level 1, "222" for level 2) by your own.

If you enter the value "000" for a code, code blocking is canceled, and you have immediate access to the corresponding operation level.

### 8.6.12 Device test (function 80)

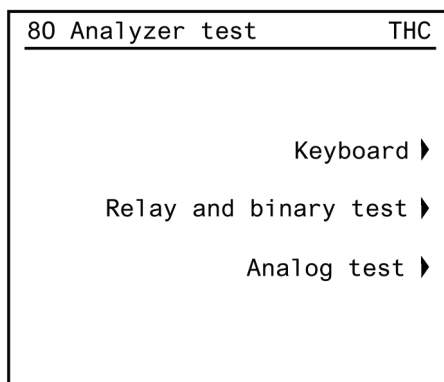

Figure 8-55 Testing the device

With this function, you can test the functional ability of the device.

#### Keyboard test

You can test all keys on the control panel by means of the keyboard test. The five softkeys on the right edge can be used to make the associated item appear/disappear. If a number key or the sign key is pressed, this is displayed in the bottom line of the display.

After pressing the [INFO] key, a message is displayed in plain text. The [MEAS] and [ESC] keys retain their "jump back" function.

### Relay and binary test

Relay-and Binary		THC
No	Relay	Binary
1	:2:	0
2	1	0
3	4	0
4	3	0
5	6	0
6	5	0

...cont. ▶

Figure 8-56 Test relay outputs and binary inputs

The first function screen shows the state of the six relay and binary inputs of the standard device. With an optional board, there are another eight relay/binary inputs on a second page.

With the relay test, individual relays can be activated. This is done via the input field. With "1", the relay is on, with "0", it returns to its release condition. Numbers other than "0" and "1" are not accepted by the input field.

After leaving function 80, the relays are back in the state they had before calling the relay and binary test.

The current state of the binary inputs is displayed in the "Binary" column.

### Analog test

With the analog test, the analog output is set to a constant current of 0 to 24000 µA for testing purposes.

The analog input displays the input currents in µA.

#### 8.6.13 Language selection (function 81)

81 Select language	THC
other	<input checked="" type="checkbox"/>
English	<input type="checkbox"/>

Figure 8-57 Selecting a language

With this function, you set the device to a second dialog language.

The device is always delivered in the ordered language. Usually, English is included as a second language (if English is the first language, Spanish is set as the second language).

### 8.6.14 Correction of cross-interference (function 83)

Correction of cross-interference is not usually necessary with the FIDAMAT 6. If you still want a cross-interference correction in particular cases, it is first necessary to distinguish what type of interference exists.

Press the first softkey. The following function screen appears on the display.

83 Interf. correct.	THC
Interference correct. 1	●
Interference correct. 2	●
Interference correct. 3	●
Interference correct. 4	●

Figure 8-58 Performing a cross-interference correction

Press the first softkey and select the type of interference. The following distinctions are possible:

- No interference correction
- Interference correction with const. influence of interfering gas
- Interference correction with variable influence on an. input
- Interference correction with variable influence via ELAN

The cross-interference correction is deactivated for the duration of a calibration process (zero or span). It becomes active again after calibration is complete and the device has returned to the "Measuring" operating state.

**Interference correction with const. influence of interfering gas**

Interf. correct. 1	THC
with const. interference correction	●
valid for range	▼ 1 2 3 4 ●
Interference:	: 0.00:
Meas. val.:	0.00 ppm C1

Figure 8-59 Constant influence of interfering gas

With softkey 2, you set whether the cross-interference correction is to apply only to certain measuring ranges.

Under *"Cross-interference deflection"*, enter the value of the zero offset.

**Correction of cross-interference with variable influence of interfering gas**

Interf. correct. 1	THC
with var. interference influence on an. input 2	●
valid for range	▼ 1 2 3 4 ●
Interfering gas.:	1.00:
causes an interference	0.00
Analog inp. 2:	0 - 20 mA ●
for range :	
0.00 - 10.00	
Meas. val.:	0.00 ppm C1

Figure 8-60 Variable influence of interfering gas

Here, a variable influence of interfering gas is active, which must be measured using a suitable separate gas analyzer and then supplied as an analog current or digital signal (via ELAN) to the device for correction of cross-interference.

Press softkey 1 again to perform the cross-interference correction via the RS 485 (ELAN) serial interface.

Here, the same inputs are to be made as for the correction of cross-interference *"... via analog input"*.

Also enter the channel number and component number of the interfering gas analyzer. The type of gas assigned to the channel and component as well as the device status appear in the display.

---

**Note**

On the device supplying the correction data, the parameter *"Measured value telegram"* (function 73) must be set to *"On"*.

---

With softkey 2, you set whether the cross-interference correction is to apply only to certain measuring ranges.

**See also**

ELAN configuration (function 73) (Page 115)

**8.6.15 Switch valves (function 85)**

85 Switch valves	THC
1 Sample pt.6	Rel. 1 <input type="checkbox"/>
2 Sample pt.2	Rel. 2 <input type="checkbox"/>
3 Sample pt.4	Rel. 3 <input type="checkbox"/>

Figure 8-61 Switching valves

With this function, you can manually switch up to six valves. This is done via the relays which are allocated to the individual valves and are available on the motherboard and optional board. The precondition is that the corresponding relays have been previously configured with function 71 ("Relay outputs")

The "Switch valves" function only applies to the relay functions "Zero gas", "Calibration gas 1 to 4" and "Sample gas".

Only one valve can be switched at a time, since the valves are mutually interlocked.

**See also**

Relay outputs (function 71) (Page 107)

### 8.6.16 Linear temperature compensation (function 86)

86 Lin.temp.comp.	THC
aftercompensation of the zero point	▶
aftercompensation of the span	▶

Figure 8-62 Compensating the temperature

The FIDAMAT 6 is temperature compensated both at the zero point as well as for the span. If an additional temperature error occurs during operation, compensate it with this function.

***"Aftercompensation of the zero point":***

Based on an average analyzer temperature, define two different correction values for ranges of increased temperature decreased temperature.

***"Aftercompensation of the span":***

The procedure is the same as for the zero point, but the change relates to the measured value.

---

**Note**

If the zero point deviates negatively when the temperature changes, the value has a positive sign, and vice-versa. The same applies to the measured value.

---



### 8.6.17 Error on/off (function 87)

87 Error On/Off	THC
S1 Parameter memory	■
S2	■
S3 Flame does not ignite	■
S4 External fault	■
...continue ▶	

Figure 8-63 Switching errors on and off

With this function, you switch the message for maintenance requests and faults off individually so that there is no entry in the logbook, no message in the status line of the measured value display and no external signal sent.

### 8.6.18 PROFIBUS configuration (function 90)

This function is used to set the PROFIBUS parameters. This function can only be called if the device contains additional PROFIBUS electronics (optional board).

90 PROFIBUS config.	THC
Address :126:	
TAG : FIDAMATSIX	
Ident number : 1:	●
Relay on PB :off:	●
Software vers: 2.0.0	
Boot software: 0.2.0	

Figure 8-64 Configuring PROFIBUS

Specifically, you can set the following specific PROFIBUS parameters:

- Address (PROFIBUS station address): The address can be set from 0 to 126.
- Under TAG you can display an identifier assigned to the device in the PROFIBUS network (or the first 16 characters thereof).
- You set the configuration behavior of the device with the "Ident number" (softkey 2). Parameters 0, 1 and 3 can be selected and have the following meaning:

Parameters	Meaning
0	Only the PROFILE Ident number is positively acknowledged
1	Only the device-specific Ident number is positively acknowledged
3	Only the PROFILE Ident number for multivariable devices (complex analyzers) is positively acknowledged.

**Note**

In order to work with the provided GSD and EDD, the value 1 must be entered for 'Ident number'.

- Relay on PB. This can be used to enable the 8 relays of the additional electronics (option board) so that they can be remotely controlled via PROFIBUS. For activating, however, none of these relays are permitted to be assigned a function.

**Note**

For remote control via PROFIBUS, the software version of the additional PROFIBUS electronics (option board) must be 2.0.0 or higher.

The current software version of the PROFIBUS card and the boot software version are indicated in the bottom lines of the display.

**8.6.19 Start-up state (function 91)**

91 Start-up state	THC
Standby	<input checked="" type="checkbox"/>
Pause	<input type="checkbox"/>
Pause without heating	<input type="checkbox"/>

Figure 8-65 Change start-up state/operating state (FIDAMAT 6-E)

91 Start-up state	THC
Pause	<input checked="" type="checkbox"/>
Pause without heating	<input type="checkbox"/>
Sample gas / standby	<input type="checkbox"/>

Figure 8-66 Change start-up state/operating state (FIDAMAT 6-G)

This function can be used to set the device to different start-up states.

#### **Standby (FIDAMAT 6-E only)**

The pump is switched off with this setting. When this state is exited, the pump is started and the device goes to 'Measuring' state. This setting serves to reduce usage of the pump without interrupting the process.

#### **Pause**

With this setting, you reduce the gas consumption by switching off the pump. This state is exited via the warm-up phase.

#### **Pause without heating**

With this setting, you reduce the gas consumption and power. In addition to the pump, the heating is also switched off. This state is exited via the warm-up phase.

#### **Sample gas/ standby (FIDAMAT 6-G only)**

With this setting you select whether the sample gas valve remains open in standby state. This enables a change from standby to measuring state with a pressure increase of the applied sample gas. This setting is available starting in firmware V1.3.5.

---

#### **Note**

##### **Change of operating state**

The operating state can be changed manually using function 91 or automatically as a result of faults/maintenance requests. You will find the possible state changes in table "Change of state due to fault/maintenance request" in section State change due to fault / maintenance request (Page 62).

---

### 8.6.20 Pressure values (function 92)

92 Pressure values	THC
Pressure hydrogen:	
Setpoint press.	: 1000 hPa
Max. difference	: : 50:hPa
Actual pressure	: 1002 hPa
Pressure combustion air:	
Setpoint press.	: 500 hPa
Max. difference	: 50 hPa
Min. rise for starting pump	: 15 hPa
Actual pressure	: 495 hPa

Figure 8-67 Changing the pressure values

Different pressure values are displayed in this function. You can change some of these values.

#### Combustion gas pressure:

Parameters	Explanation
Setpoint press.	Is automatically displayed
Max. difference	If the combustion gas pressure deviates from the setpoint pressure by this value, the device exits the "Measuring" operating state. This value can be changed.
Actual pressure	Is automatically displayed

#### Pressure combustion air:

Parameters	Explanation
Setpoint press.	Is automatically displayed
Max. difference	If the combustion air pressure deviates from the setpoint pressure by this value, the device exits the "Measuring" operating state. This value can be changed.
Min. rise for starting pump	When the pump starts, the combustion air pressure must rise by this value for the device to go to "Measuring" operating state. This value can be changed.
Actual pressure	Is automatically displayed

### 8.6.21 Dimensions (function 93)

93 Dimension		THC
Name	:	THC
Dimension	:	ppm C1 ●

Figure 8-68 Changing dimensions

With this function, you can change the dimensions. The name, however, cannot be changed.

Press softkey 3 in order to select from the following settings:

- ppm C1
- ppm C3
- ppm C6
- mg C/m<sup>3</sup>

### 8.6.22 Factory settings (function 99)

With this function, the operator can access the factory functions level. These settings are intended only for maintenance personnel and are therefore protected by an additional code.

After activating this function, a message appears which prompts you to enter the corresponding code.



## Service and maintenance

### 9.1 General safety information for service and maintenance

 <b>WARNING</b>
<b>Dangerous voltage at open device</b> Danger of electrocution Danger of electrocution exists when the enclosure is opened, or enclosure parts are removed. <ul style="list-style-type: none"><li>• Before you open the enclosure or remove enclosure parts, deenergize the device and wait another 10 minutes. Ensure that the device cannot be switched back on inadvertently.</li><li>• Observe the special precautionary measures if maintenance is required while the device is live. Have the maintenance work carried out by certified personnel with special training for live-line working.</li><li>• Open the enclosure only for installation or maintenance. Close the enclosure after completing this work.</li></ul>

 <b>WARNING</b>
<b>Danger from gas lines under pressure</b> Danger of injury during maintenance work Hot, toxic or corrosive sample gases can be released when the gas lines are opened. Prevent gases from exiting prior to opening or removing the device. <ul style="list-style-type: none"><li>• Do not loosen process connections and do not remove any pressurized parts while the device is under pressure.</li><li>• Depressurize the device. Shut off the gas inlets and gas outlets. Disconnect the gas lines from the device.</li><li>• Before opening or removing the device, ensure that process media cannot be released.</li></ul>

 <b>WARNING</b>
<b>Faulty adjustment and reassembly</b> Faulty mounting or calibration can lead to dangerous gas leaks. This can lead to intoxications or burns as well as corrosion damage at the device. <ul style="list-style-type: none"><li>• Only carry out adjustments using appropriate tools in order to avoid short-circuits on the electronic PCBs.</li></ul>



<b>! CAUTION</b>
<b>Hot surfaces due to hot sample gases and high-temperature devices</b>
Danger of burns due to surface temperatures above 70 °C (155 °F)
The inside of the oven reaches a temperature of approximately 200 °C during operation. After being switched off, the device and its parts are still very hot and the temperature only drops very slowly. You can call up the actual temperature of the oven and other temperature parameters via the Diagnostic values (function 2) (Page 77).
Contact with skin may result in burns.
<ul style="list-style-type: none"><li>• Wait until the device has cooled down before starting maintenance work or decommissioning.</li><li>• Take appropriate protective measures during maintenance, e.g. contact prevention.</li></ul>

<b>! CAUTION</b>
<b>Electrostatic discharges</b>
All electronic assemblies are equipped with highly integrated circuits or components. For technological reasons, these electronic components are highly sensitive to overvoltage and thus to discharges of static electricity.
Electrostatic sensitive devices (ESD) devices can be destroyed by voltages well below the threshold of human perception. These static voltages develop when you touch a component or electrical connections of a device without having discharged the electrostatic charges from your body. The damage an assembly incurs due to overvoltage is often not immediately detectable but rather becomes apparent only after an extended operation time.
To avoid damage from electrostatic discharges, take the following precautions:
<ul style="list-style-type: none"><li>• Make sure all persons, workplaces and packaging are sufficiently grounded when ESDs are being handled. This prevents electrostatic charge.</li><li>• You should only touch ESDs if this is unavoidable. In such cases, handle the assemblies without touching any chip pins or PCB traces.</li><li>• If you must perform measurements on an assembly, discharge your body before commencing work. Do so by touching grounded metallic objects. Always use grounded measuring instruments.</li></ul>

<b>! CAUTION</b>
<b>Faults at the device</b>
For faults which you are unable to eliminate, place the device out of service and protect it against inadvertent commissioning.



**NOTICE****Penetration of moisture into the device**

Device damage.

- Make sure when carrying out cleaning and maintenance work that no moisture penetrates the inside of the device.

## 9.2 General information on maintenance

Depending on the use of the device and certain empirical values, determine a maintenance interval for the tests to be carried out repeatedly.

The maintenance intervals will vary from site to site depending on corrosion resistance.

## 9.3 Maintaining the device

Perform the following maintenance work:

- Check the device annually:
  - For electrical safety and function
  - For leakage of the sample gas path within the device
- Check the device for leaks after every intervention in the gas path. Refer to section "Checking for leaks (Page 56)" for information on this.
- **FIDAMAT 6-E:** Perform pump maintenance every 6 months. Replace the pump diaphragm.

---

**Note**

If gaskets that come in contact with sample gas are not expected to be negatively affected by chemical corrosion, the owner may at its discretion extend the maintenance interval in special cases.

---

## 9.4 Cleaning the device

### Cleaning the surface

<b>NOTICE</b>
<b>Moisture inside the analyzer</b>
Make sure that no water gets inside the device during cleaning.

The front panel and control panel can be wiped clean. In hazardous areas, only clean with a moist cloth. We recommend water as cleaning agent, with a standard dishwashing liquid added.

In the display area, apply only light pressure on the surface. The thin membrane could otherwise be damaged.

### Cleaning the interior

After opening the device, you can blow out the interior carefully with a compressed air gun, if necessary.

## 9.5 Replacing the motherboard and option board

The motherboard, option board and adapter board can be replaced/retrofitted.

### Removing the motherboard

To remove, proceed as follows:

1. Disconnect the device from the power supply.
2. Loosen the screws on the housing cover and remove it.
3. Remove the connected data plug from the rear of the housing.
4. Loosen the three screws located between the D-sub connectors on the rear of the device.
5. Detach the plug-in connectors on the motherboard.
6. Carefully remove the motherboard.

To install boards, carry out the same steps in the opposite order.

### Removing the option board/adapter board

The procedure is the same as for the motherboard. Unlike the motherboard, both the option and adapter boards are fixed to the rear of the housing with only two screws.

## 9.6 Replacing line fuses

---

### Note

The device is protected against various influences (e.g. supply voltage, heating) with multiple fuses. Even if only one line fuse is defective, always replace **both** line fuses.

---

### Procedure

1. Disconnect the device from the power supply.
2. Open the fuse drawer at the power socket of the device and remove it.
3. Check the fuses for damage.
4. In case of damage, replace **both** fuses with fuses having the required technical specifications.
5. Insert the fuse drawer again.

To replace the thermal fuse, proceed as follows:

1. Disconnect the device from the power supply.
2. Remove the housing cover.
3. Withdraw the three cables from the housing of the thermal cut-out.  
The housing is mounted on the front panel to the right of the two pressure regulators.
4. Loosen the retaining nuts of the housing.
5. Remove the housing.
6. Open the oven.
7. Release the fixing clamp and remove the sensor of the thermal cut-out.

To install the new thermal fuse, carry out the same steps in the opposite order.

## 9.7 Maintenance request and fault message

The FIDAMAT 6 is able to detect functional irregularities. These appear as "Maintenance request" or "Fault" in the status line of the measured-value display. At the same time, they are recorded in the logbook and can be called up there. You acknowledge the message by pressing the softkey next to the corresponding logbook entry. If you do not eliminate the causes, the messages will appear again.

When a new message appears, the record stored in the logbook is shifted back one place in the memory. There is a total of 32 memory location available. If all 32 memory locations are already occupied when another record arrives (No. 33), the oldest one (No. 1) is overwritten.

Logbook entries that must be acknowledged are marked with a "Q" under the number in the No. column of the following lists.

You can lock the logbook or even clear the messages in it with function 60. This can be especially helpful during test operation.

9.7 Maintenance request and fault message

All messages can be turned off individually under function 87. In normal operation, we recommend that this option not be used.

**Maintenance request**

If there are indications of changes to device-internal parameters, "Maintenance request" appears in the status line. Such changes do not affect the measuring capability of the device at the time they occur. However, in order to guarantee the measuring capability in the long-term, you may need to take remedial measures.

If you have configured the relay output of the device accordingly (function 71), there is also an external signal.

**Fault**

Defects in the hardware or changes in the device parameters that would make the device unfit to take measurements trigger a fault message. "Fault" then appears in the status bar of the measured-value display. The measured value flashes. Remedial measures are essential!

As with the maintenance request, an external signal can be sent via the relay output (function 71). In addition, you can set the analog output to the output current range that you have set with function 77 (measured value memory).

**Further messages**

Besides the maintenance request and fault messages, other important messages are listed in the logbook:

Message in status bar	Meaning
LIM 1 – 4	Limits (measuring range 1 – 4) were exceeded / fallen below
CTRL	Function control. If the device activates the function control, this is noted in the logbook.

**See also**

Logbook settings (function 60) (Page 103)

Relay outputs (function 71) (Page 107)

Analog output memory (function 77) (Page 119)

Error on/off (function 87) (Page 127)

## 9.8 List of maintenance requests

For FIDAMAT 6, the following messages require a maintenance request (display in the status line and storage in the logbook) and are signaled externally if you have configured a corresponding relay under function 71.

With function 87, you can switch off each maintenance request individually, which means suppressing the display in the status line, storage in the logbook and the external signal.

Table 9- 1 Maintenance requests

No.	Message	Possible causes	Remedy	Notes
W1 Q	Calibration difference too great	Calibration gas was changed	Repeat calibration	Calibration tolerance, see also function 78; drift of channel according to technical data: zero point: 1% of full-scale value/week, span: 1% of full-scale value/week
		Drift behavior due to contaminated gas lines	Check whether drift is normal; check gas lines for contamination and replace if necessary.	
W4 Q	Set clock (function 58)	The device was switched off.	New input of date and time	Function 58
W5 Q	Combustion air pressure/ combustion gas pressure	Combustion air pressure/sample gas pressure too high or too low;	<ul style="list-style-type: none"> <li>• Check seal of exhaust gas restrictor (restrictor 4)</li> <li>• Check tubing</li> <li>• Readjust pressure value with pressure regulator</li> </ul>	The device changes to the "Warm-up phase" operating state.  With firmware version 1.2 and higher, the device will only leave this state when the maintenance request has been acknowledged.
		Combustion gas primary pressure too high or too low.	See above	
		Limits have been chosen too close.	See above	
		Sample gas supply malfunction: <ul style="list-style-type: none"> <li>• Pump defective</li> <li>• Pump diaphragms defective</li> <li>• Filter clogged</li> <li>• Leaky lines/connections</li> <li>• External sample gas line/ sampling probe clogged</li> </ul>	Replace pump Replace pump diaphragms Replace filter Check lines/ connections/ seals and replace, if necessary Check gas lines and sampling probe for contamination and replace if necessary.	

9.9 List of faults

No.	Message	Possible causes	Remedy	Notes
W6 Q	Temperature sensor display	Ambient temperature outside tolerances of 5 °C ... 45 °C	Make sure that the ambient temperature is in the permissible range of 5 °C ... 45 °C	
		Display defective	Replace display	
		Temperature sensor defective	Replace temperature sensor	
W7 Q	Electronics/hardware temperature	Temperature sensor defective, ambient temperature outside tolerance	Replace temperature sensor Make sure that the ambient temperature is in the range of 5 °C ... 45 °C	
W8 Q	Flame is out	Combustion gas cylinder empty	Check combustion gas pressure, check combustion air pressure	See W5
		Combustion air supply interrupted		
		Supply lines to the FID clogged		
W9	External maintenance request	External signal	Check	Function 72 must be configured accordingly
W10	AUTOCAL-/check deviation	In an "AUTOCAL-/check", it was found that the tolerances were violated.	Perform AUTOCAL again	This message disappears only after the AUTOCAL has been successfully completed.

**See also**

- Relay outputs (function 71) (Page 107)
- Binary inputs (function 72) (Page 109)
- Calibration tolerances (function 78) (Page 119)
- Switch valves (function 85) (Page 125)
- Error on/off (function 87) (Page 127)

**9.9 List of faults**

The faults listed below result in a fault message (display in the status line and storage in the logbook) and are signaled externally if you have configured a corresponding relay under function 71.

Immediate remedial measures by qualified maintenance personnel must always be taken here. There is a defect in the device. The measurements are incorrect.

With function 87, you can switch off each fault individually, which means suppressing the display in the status line, storage in the logbook and the external signal.

When a fault occurs, the device leaves the "Measure" operating state. After eliminating the fault, you must leave this new state ("Standby"/"Pause"/"Pause without heating") again using function 91 in order to return the device to the "Measuring" state.

Table 9-2 Faults

No.	Fault message	Explanation	Possible causes	Remedy
S1 Q	Parameter memory	Parameter memory test failed	EEPROM contains incorrect or incomplete data in the working range	<ul style="list-style-type: none"> <li>Execute reset (function 74) or turn the device off and on again.</li> </ul> <p>If the error message S1 appears again:</p> <ul style="list-style-type: none"> <li>Load user data (function 75)</li> <li>Inform service</li> </ul> <p><b>Leave the device in operation in order to facilitate fault diagnostics by service personnel!</b></p>
S2 Q	Pump does not start up (FIDAMAT 6-E only)		<ul style="list-style-type: none"> <li>Combustion air pressure (sample gas) too high</li> <li>Pump defective</li> </ul>	<ul style="list-style-type: none"> <li>Check combustion air pressure</li> <li>Repair/replace pump</li> </ul>
S3 Q	Flame does not ignite		<ul style="list-style-type: none"> <li>No combustion gas or no combustion air available</li> <li>Ignition cable defective</li> <li>No ignition spark</li> <li>Energy of ignition spark too low</li> </ul>	<ul style="list-style-type: none"> <li>Check combustion gas/combustion air supply</li> <li>Replace ignition cable</li> <li>Check high-voltage (ignition cable)</li> <li>Call service</li> </ul>
S4	External fault		External fault signal	Check: Function 72 must be configured accordingly
S5 Q	Oven temperature	Oven temperature is outside tolerance	Temperature sensor defective	Check temperature sensor.
S7 Q	Flame temperature	Flame temperature is outside tolerance	Temperature sensor defective	Check temperature sensor
S8 Q	Combustion air pressure/combustion gas pressure	Combustion air pressure (sample gas) or combustion gas pressure outside tolerance	<ul style="list-style-type: none"> <li>Pressure sensor defective</li> <li>Pressures incorrectly adjusted</li> </ul>	<ul style="list-style-type: none"> <li>Check pressure sensor</li> <li>Check pressure and adjust if necessary using the pressure regulators</li> </ul>
S9 Q	Heating is off	Heater has switched off	<ul style="list-style-type: none"> <li>The set temperature was not reached</li> </ul>	<ul style="list-style-type: none"> <li>Check heating elements</li> <li>Check temperature sensor in the oven</li> </ul>

9.10 Other faults

No.	Fault message	Explanation	Possible causes	Remedy
		Thermal cut-out has triggered	<ul style="list-style-type: none"> <li>Defect of the electronic heating control</li> <li>Overshooting of the maximum permissible oven temperature</li> </ul>	<ul style="list-style-type: none"> <li>The triggering of the thermal cut-out signals a defect of the electronic heating control. The device is no longer ready for operation and <b>a repair must be carried out before starting up again.</b> The thermal cut-out itself can be manually reset. After the triggering, the sensor temperature must fall by 20 °C before a reset is possible by means of the reset button on the front panel.</li> </ul>
S10 Q	24 h RAM/Flash check		RAM/Flash defective	Replace motherboard
S12 Q	Line voltage supply		Line voltage supply outside tolerance	Bring the line voltage within the specified tolerance limits according to the rating plate
S13 Q	Hardware		Internal supply outside tolerance	<ul style="list-style-type: none"> <li>Check diagnostic values</li> <li>Replace motherboard / adapter board</li> </ul>
S14	Measured value > full-scale value of characteristic	Measured value is greater than full-scale value of characteristic (+5%)	<ul style="list-style-type: none"> <li>Incorrect calibration</li> <li>Wrong calibration gas</li> <li>Sample gas concentration too high</li> </ul>	<ul style="list-style-type: none"> <li>Repeat calibration</li> <li>Check calibration gas</li> <li>Check measuring range</li> </ul>
S15 Q	Calibration aborted		Operation was aborted during an AUTOCAL	

See also

- Relay outputs (function 71) (Page 107)
- Binary inputs (function 72) (Page 109)
- Save / load data (function 75) (Page 116)
- Error on/off (function 87) (Page 127)
- Start-up state (function 91) (Page 128)

9.10 Other faults

Regularly calibrate the device at the zero point (function 20) and span (function 21) with the corresponding calibration gases in accordance with the drift data. Make sure the gases are purified properly.

A larger zero drift is usually a sign that residues or dust particles have deposited in the FID.



The following faults are not signaled or stored by the device but are only detectable based on characteristic measured values.

Table 9- 3 Other faults

<b>Fault</b>	<b>Possible cause and its elimination</b>
Large positive zero drift	<ul style="list-style-type: none"><li>• Check gas preparation system</li><li>• Clean FID</li></ul>
Large span drift	<ul style="list-style-type: none"><li>• Detector leaky</li><li>• FID nozzle defective</li></ul>
Span depends strongly on flow	Exhaust gas line is congested/clogged, e.g. by water condensation

### See also

Zero calibration (function 20) (Page 80)

Span calibration (function 21) (Page 80)

Cleaning the device (Page 136)

General technical data of the FIDAMAT 6 gas analyzers (Page 167)



## Spare parts and accessories

### 10.1 Ordering information

The spare parts list reflects the technical status in December 2019.

The rating plate shows the year of manufacture of the gas analyzer coded in the serial number. For more information, refer to the section "Date of manufacture (Page 12)".

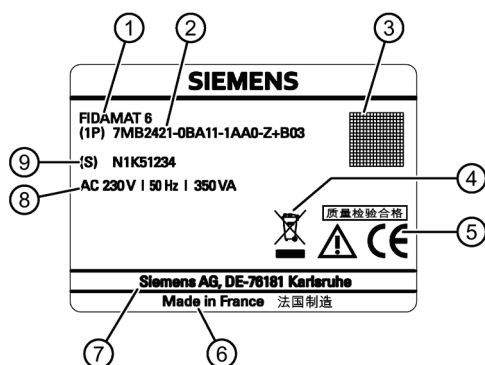

- |   |                                    |
|---|------------------------------------|
| ① Device name   | ⑥ Designation of origin            |
| ② Complete article number of the device (MLFB number) | ⑦ Name and address of manufacturer |
| ③ Data matrix code                                    | ⑧ Type of power supply             |
| ④ Disposal information according to DIN EN 54019      | ⑨ Serial number                    |
| ⑤ CE conformity marking                               |                                    |

Figure 10-1 Rating plate

### Ordering information

The order for spare parts must contain the following information:

- Quantity
- Designation of the spare part
- Article number of the spare part
- Device name, MLFB and serial number of the gas analyzer for which the spare part is intended

## 10.2 Spare parts list

**Ordering example:**

1 (unit)

Sample gas pump for FIDAMAT 6-E

A5E00882121

FIDAMAT 6, 7MB2421-0DA10-0AA0, N1RD204

**10.2 Spare parts list**

Table 10- 1 Spare parts list

Spare part	Comment	Article number
Union nuts	Pack of 10	C79451-A3040-D126
Outer rings	Pack of 20	C79451-A3040-D121
Gaskets	Pack of 20	C79451-A3040-D102
Pressure rings	Pack of 20	C79451-A3040-D112
Union nuts	Pack of 10	C79451-A3040-D127
Outer rings	Pack of 20	C79451-A3040-D122
Gaskets	Pack of 20	C79451-A3040-D103
Pressure rings	Pack of 20	C79451-A3040-D113
Gaskets	Pack of 20	C79451-A3040-D105
Gaskets	Pack of 20, PTFE	C79451-A3040-D101
Pressure rings	Pack of 20	A5E00295333
4-way distributor T1		A5E00296582
3-way distributor T2		A5E00296585
3-way distributor T3		A5E00296588
3-way distributor T4		A5E00296591
3-way distributor T5 (FIDAMAT 6-E)		A5E00296593
4-way distributor T6 (FIDAMAT 6-E)		A5E00296597
4-way distributor T6/ T9/ T13 (FIDAMAT 6-G)		
3-way distributor T7/ T8		A5E00296598
3-way distributor T10/ T11/ T12 (FIDAMAT 6-G)		A5E00417431
Connector V1/ V2		A5E00296599
Connector V3 (FIDAMAT 6-G)		A5E00481710
Set of unions	6 mm	A5E00313822
Set of unions	¼"	A5E00313831
1-way solenoid valve		A5E00296562
2-way solenoid valve (FIDAMAT 6-E)		A5E00296565
Gas feed-through	6 mm connection GE1-4	A5E00296560
Gas feed-through	¼" connection GE1-4	A5E00296552

Spare part	Comment	Article number
Insulation	Sample gas inlet	A5E00297363
Insulation	Gas exhaust	A5E00297369
Gas exhaust	6 mm	A5E00299845
Gas exhaust	¼"	A5E00299847
Crimp restrictor DR1		A5E00296569
Crimp restrictor DR2		A5E00296570
Crimp restrictor DR3		A5E00296571
Crimp restrictor DR4		A5E00296573
Crimp restrictor DR5 (FIDAMAT 6-E)		A5E00296576
Restrictor lines DR6 (FIDAMAT 6-E)	Restrictor line 4FS, complete DR6	A5E00296070
Damping restrictor DR7 (FIDAMAT 6-E)	complete with tube and gas-kets	A5E00313836
Crimp restrictor DR8		A5E00296580
Crimp restrictor DR9, DR10, DR11 (FIDAMAT 6-G)		A5E00417401
Crimp restrictor DR12 (FIDAMAT 6-G)		A5E00782981
Crimp restrictor DR13 (FIDAMAT 6-G)	Restrictor line 1FS, complete DR13	A5E00417394
Motherboard FIDAMAT 6-E	with firmware, German	A5E00295472
Motherboard FIDAMAT 6-E	with firmware, English	A5E00295543
Motherboard FIDAMAT 6-E	with firmware, French	A5E00295560
Motherboard FIDAMAT 6-E	with firmware, Spanish	A5E00295987
Motherboard FIDAMAT 6-E	with firmware, Italian	A5E00295988
Motherboard FIDAMAT 6-G	with firmware, German	A5E00410267
Motherboard FIDAMAT 6-G	with firmware, English	A5E00410309
Motherboard FIDAMAT 6-G	with firmware, French	A5E00410321
Motherboard FIDAMAT 6-G	with firmware, Spanish	A5E00410324
Motherboard FIDAMAT 6-G	with firmware, Italian	A5E00410326
Firmware FIDAMAT 6-E	German	A5E00223093
Firmware FIDAMAT 6-E	English	A5E00223146
Firmware FIDAMAT 6-E	French	A5E00223149
Firmware FIDAMAT 6-E	Spanish	A5E00223152
Firmware FIDAMAT 6-E	Italian	A5E00223155
Firmware FIDAMAT 6-G	German	A5E00409885
Firmware FIDAMAT 6-G	English	A5E00409929
Firmware FIDAMAT 6-G	French	A5E00409947
Firmware FIDAMAT 6-G	Spanish	A5E00409962
Firmware FIDAMAT 6-G	Italian	A5E00409966
Adapter board FIDAMAT 6		A5E00248795
Read-only memory adapter board FIDAMAT 6		A5E00299353
Adapter board LCD/keyboard		C79451-A3474-B605

## 10.2 Spare parts list

Spare part	Comment	Article number
Front panel FIDAMAT 6		A5E00248790
Axial-flow fan, 24 V DC - 4500 rpm		A5E00313839
LCD display		A5E31474846
Thermal cut-out		A5E01040317
Device fuse	230 V T 2.5 A	A5E00248819
Device fuse	115 V T 4 A	A5E00248822
Transformer	230 V	A5E00308871
Transformer	115 V	A5E00308869
Sample gas pump (FIDAMAT 6-E)		A5E00882121
Rubber pad for sample gas pump (FIDAMAT 6-E)		A5E47395381
Gasket set for pump (FIDAMAT 6-E)		A5E03792459
Filter with gasket for sample gas (FIDAMAT 6-E)		A5E00248845
Filter (FIDAMAT 6-E)	Complete, 6 mm	A5E00295928
Filter (FIDAMAT 6-E)	complete, 1/4"	A5E00295976
Pressure regulator FIDAMAT 6		A5E00248851
Gasket and fitting for pressure regulator		A5E00295107
FID oven insert FIDAMAT 6-E		A5E00248859
FID oven insert FIDAMAT 6-G		A5E00429789
FI detector	Complete	A5E00295816
Oven (FIDAMAT 6-E)	complete without analyzer part	A5E00295345
Oven (FIDAMAT 6-G)	complete without analyzer part	A5E00434086
Pressure sensor 1	for combustion gas, with cable	A5E00284096
Pressure sensor 2	for combustion air, with cable	A5E00284095
Cable	Temperature sensor for oven FIDAMAT 6	A5E00283770
Cable	Temperature sensor for analyzer part FIDAMAT 6	A5E00283780
Cable	Solenoid valve MV1 – MV4	A5E00283800
Cable (FIDAMAT 6-G only)	Solenoid valve MV5-MV6	A5E00422610
Cable with heating elements	Heater for oven 230 V	A5E00283817
Cable with heating elements	Heater for oven 115 V	A5E00295469
Cable	RS232 interface	A5E00284087
Cable	Polarization voltage	A5E00284092
Cable	Measurement cable 230 V	A5E00284094
Cable	RS485	A5E00284100

## 10.3 Gas flow diagram with spare parts

### 10.3.1 Gas flow diagram of FIDAMAT 6-E

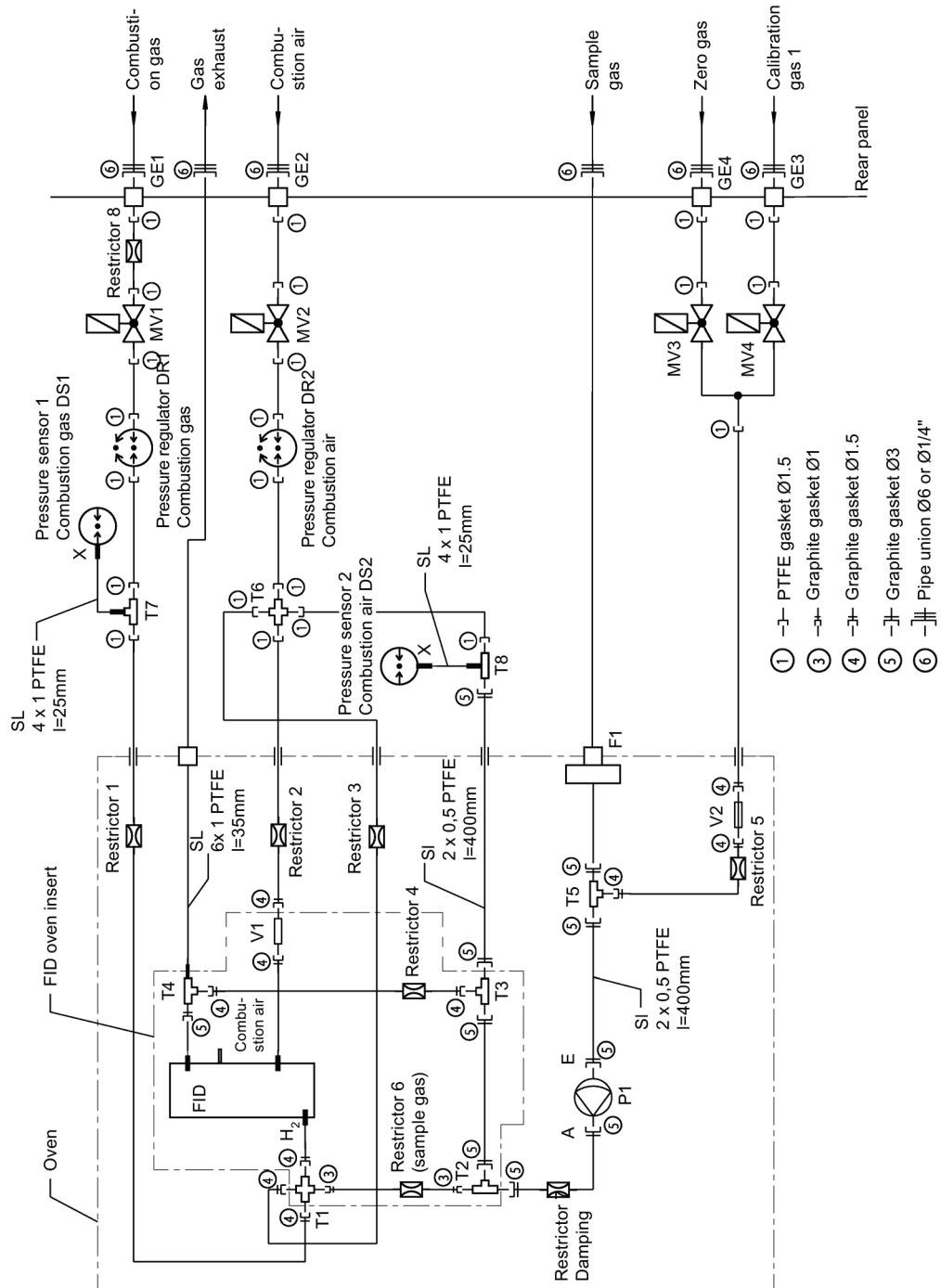

Figure 10-2 Gas flow diagram with spare parts/gaskets of FIDAMAT 6-E

## 10.3 Gas flow diagram with spare parts

Table 10-2 Gasket parts in the gas flow

Gasket type	Spare part	Article number	Quantity
①	Nut	C79451-A3040-D127	10
	PTFE gasket	C79451-A3040-D101	20
	Pressure ring	C79451-A3040-D113	20
	Outer ring	C79451-A3040-D122	20
③	Nut	C79451-A3040-D126	10
	Graphite gasket 1 mm	C79451-A3040-D102	20
	Pressure ring	C79451-A3040-D112	20
	Outer ring	C79451-A3040-D121	20
④	Nut	C79451-A3040-D127	10
	Graphite gasket 1.5 mm	C79451-A3040-D103	20
	Pressure ring	C79451-A3040-D113	20
	Outer ring	C79451-A3040-D122	20
⑤	Nut	C79451-A3040-D127	10
	Graphite gasket 3 mm	C79451-A3040-D105	20
	Pressure ring	A5E00295333	20
	Outer ring	C79451-A3040-D122	20
⑥	Union 6 mm (nut and ring)	A5E00313822	1
	Screw fitting ¼" (nut and ring)	A5E00313831	1

Table 10-3 Spare parts in gas flow

Notation in the gas flow diagram	Spare part	Article number	Quantity
GE1 – 4	Gas fitting (¼")	A5E00296552	1
GE1 – 4	Bushing (gas feed-through) (6 mm)	A5E00296560	1
Restrictor 1	Crimp restrictor (combustion gas)	A5E00296569	1
Restrictor 2	Crimp restrictor (combustion air)	A5E00296570	1
Restrictor 3	Crimp restrictor (admixed air)	A5E00296571	1
Restrictor 4	Crimp restrictor (exhaust gas)	A5E00296573	1
Restrictor 5	Crimp restrictor (calibration gas)	A5E00296576	1
Restrictor 6	Restrictor line 4FS L850 (sample gas)	A5E00296070	1
Restrictor 7	Damping restrictor complete with tube and seals	A5E00313836	1
Restrictor 8	Crimp restrictor (safety)	A5E00296580	1
T1	4-way distributor	A5E00296582	1
T2	3-way distributor	A5E00296585	1
T3	3-way distributor	A5E00296588	1
T4	3-way distributor	A5E00296591	1
T5	3-way distributor	A5E00296593	1
T6	4-way distributor	A5E00296597	1



Notation in the gas flow diagram	Spare part	Article number	Quantity
T7/ T8	3-way distributor	A5E00296598	1
V1/ V2	Connector	A5E00296599	1
MV1/MV2	1-way solenoid valve	A5E00296562	1
MV3/MV4	2-way solenoid valve	A5E00296565	1
DR1/DR2	Pressure regulator DR1 (combustion gas)/pressure regulator DR2 (combustion air)	A5E00248851	1
DS1	Pressure sensor 1 (combustion gas)	A5E00284096	1
DS2	Pressure sensor 2 (combustion air)	A5E00284095	1
FID	FI detector	A5E00295816	1
FID oven insert	FID oven insert	A5E00248859	1

### 10.3.2 Gas flow diagram of FIDAMAT 6-G

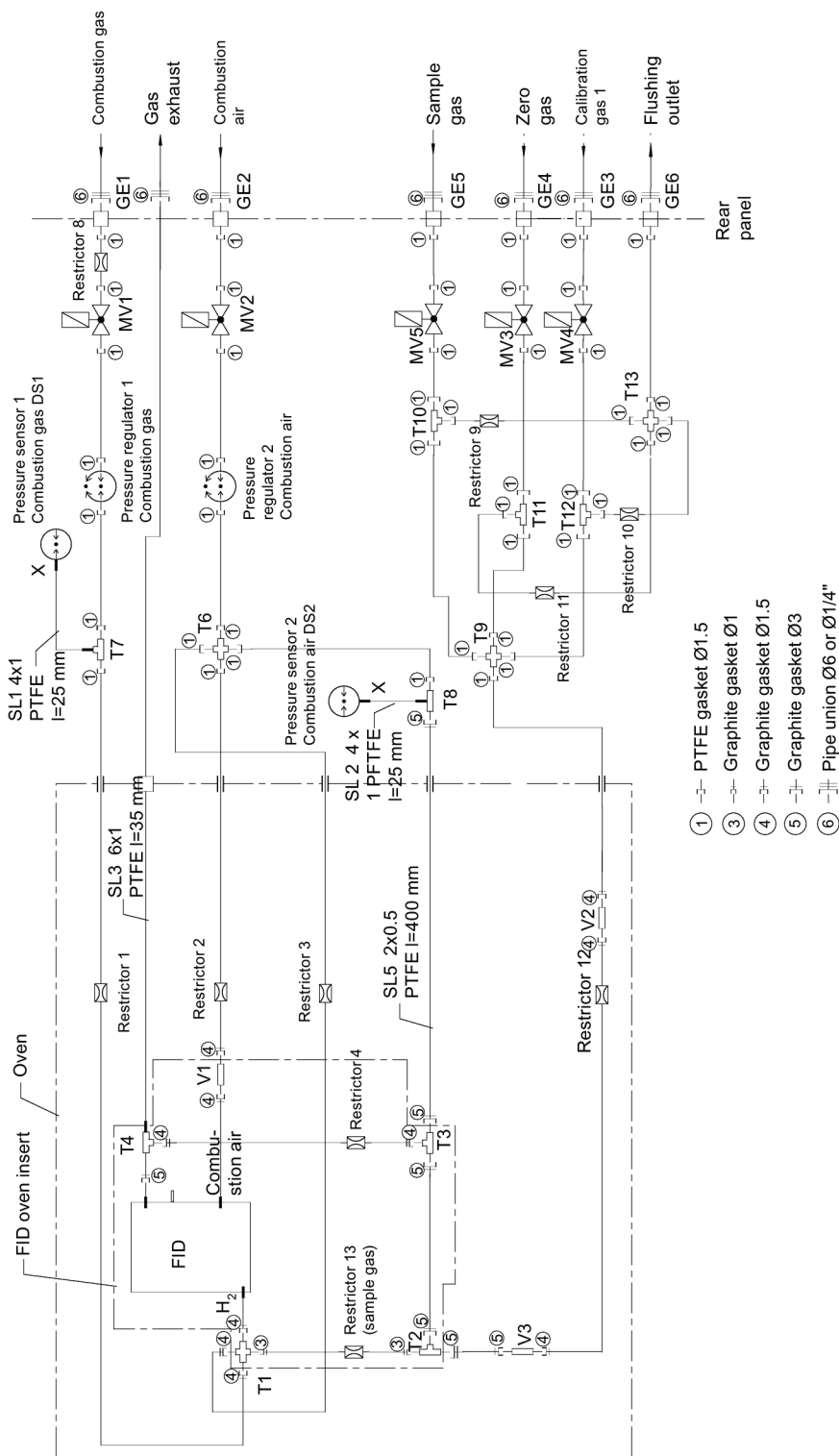

Figure 10-3 Gas flow diagram with spare parts/gaskets of FIDAMAT 6-G

Table 10- 4 Gasket parts in the gas flow

Gasket type	Spare part	Article number	Quantity
①	Nut	C79451-A3040-D127	10
	PTFE gasket	C79451-A3040-D101	20
	Pressure ring	C79451-A3040-D113	20
	Outer ring	C79451-A3040-D122	20
③	Nut	C79451-A3040-D126	10
	Gasket, graphite 1	C79451-A3040-D102	20
	Pressure ring	C79451-A3040-D112	20
	Outer ring	C79451-A3040-D121	20
④	Nut	C79451-A3040-D127	10
	Gasket, graphite 1, 6	C79451-A3040-D103	20
	Pressure ring	C79451-A3040-D113	20
	Outer ring	C79451-A3040-D122	20
⑤	Nut	C79451-A3040-D127	10
	Gasket, graphite 3	C79451-A3040-D105	20
	Pressure ring	A5E00295333	20
	Outer ring	C79451-A3040-D122	20
⑥	Union 6 mm (nut and ring)	A5E00313822	1
	Union ¼" (nut and ring)	A5E00313831	1

Table 10- 5 Spare parts in gas flow

Notation in the gas flow diagram	Spare part	Article number	Quantity
GE1 – 6	Gas feed-through (¼")	A5E00296552	1
GE1 – 6	Bushing (gas feed-through) (6 mm)	A5E00296560	1
Restrictor 1	Crimp restrictor (combustion gas)	A5E00296569	1
Restrictor 2	Crimp restrictor (combustion air)	A5E00296570	1
Restrictor 3	Crimp restrictor (admixed air)	A5E00782865	1
Restrictor 4	Crimp restrictor (exhaust gas)	A5E00296573	1
Restrictor 8	Crimp restrictor (safety)	A5E00296580	1
Restrictor 9/ 10/ 11	Crimp restrictor	A5E00417401	1
Restrictor 12	Crimp restrictor	A5E00782981	1
Restrictor 13	Crimp restrictor, restrictor line 1FS (sample gas)	A5E00417394	1
T1	4-way distributor	A5E00296582	1
T2	3-way distributor	A5E00296585	1
T3	3-way distributor	A5E00296588	1
T4	3-way distributor	A5E00296591	1
T6/ T9/ T13	4-way distributor	A5E00296597	1

10.3 Gas flow diagram with spare parts

Notation in the gas flow diagram	Spare part	Article number	Quantity
T7/ T8	3-way distributor	A5E00296598	1
T10/ T11/ T12	3-way distributor	A5E00417431	1
V1/ V2	Connector	A5E00296599	1
V3	Connector	A5E00481710	1
MV1/ MV2 / MV3/ MV4/ M V5	1-way solenoid valve	A5E00296562	1
DR1/DR2	Pressure regulator 1 (combustion gas)/pressure regulator 2 (combustion air)	A5E00248851	1
DS1	Pressure sensor 1 (combustion gas)	A5E00284096	1
DS2	Pressure sensor 2 (combustion air)	A5E00284095	1
FID	FI detector	A5E00295816	1
FID oven insert	FID oven insert	A5E00429789	1

## 10.4 Device views with spare part numbers

### 10.4.1 Device views of FIDAMAT 6-E

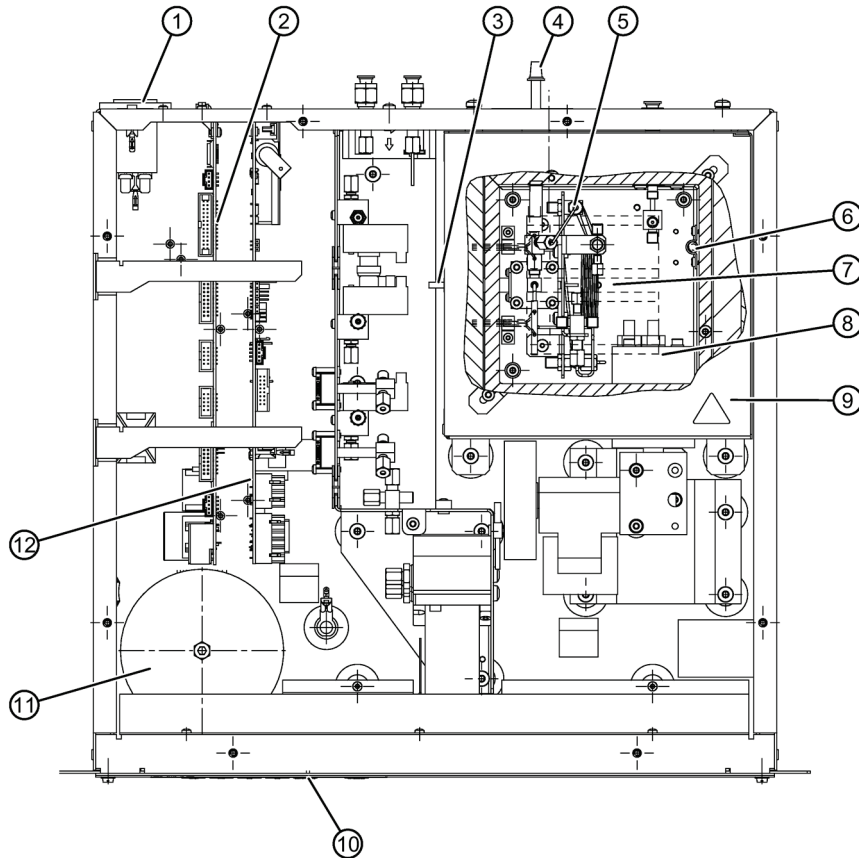

①	Device fuse 230V F 6	A5E00248819
	Device fuse 115V F 6	A5E00248822
②	Firmware FIDAMAT 6-E German	A5E00223093
	Firmware FIDAMAT 6-E English	A5E00223146
	Firmware FIDAMAT 6-E French	A5E00223149
	Firmware FIDAMAT 6-E Spanish	A5E00223152
	Firmware FIDAMAT 6-E Italian	A5E00223155
	Motherboard with firmware FIDAMAT 6-E German	A5E00295472
	Motherboard with firmware FIDAMAT 6-E English	A5E00295543
	Motherboard with firmware FIDAMAT 6-E French	A5E00295560
	Motherboard with firmware FIDAMAT 6-E Spanish	A5E00295987
	Motherboard with firmware FIDAMAT 6-E Italian	A5E00295988

10.4 Device views with spare part numbers

③	Cable, temperature sensor for oven F 6	A5E00283770
④	Gas exhaust 6 mm	A5E00299845
	Gas exhaust 1/4"	A5E00299847
⑤	FID oven insert FIDAMAT 6-E	A5E00248859
⑥	Thermal cut-out	A5E01040317
⑦	Cable, heater for oven 230 V	A5E00283817
	Cable, heater for oven 115 V	A5E00295469
⑧	Pump FIDAMAT 6-E	A5E00882121
	Gasket set for pump FIDAMAT 6-E	A5E03792459
⑨	Oven complete without analyzer part	A5E00295345
⑩	Front panel FIDAMAT 6	A5E00248790
	LCD display FIDAMAT 6	A5E31474846
⑪	Transformer 115 V	A5E00308869
	Transformer 230 V	A5E00308871
⑫	Adapter board FIDAMAT 6	A5E00248795
	Read-only memory FIDAMAT 6	A5E00299353

Figure 10-4 Top view

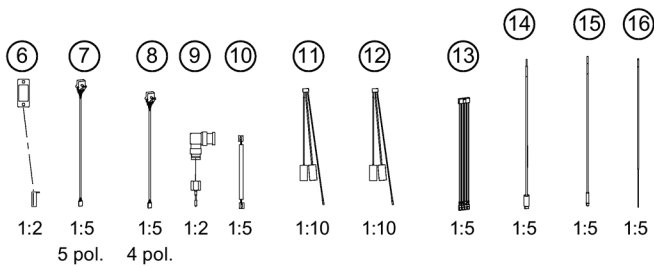
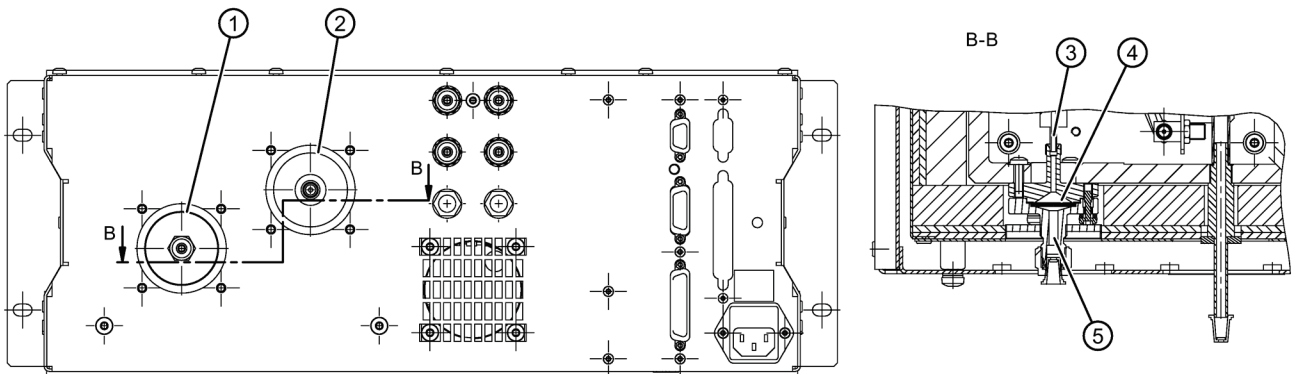

①	Sample gas inlet insulation	A5E00297363
②	Gas exhaust insulation	A5E00297369
③	Union nuts	C79451-A3040-D127
	Outer rings	C79451-A3040-D122
	Gaskets	C79451-A3040-D105
	Pressure rings	A5E00295333
④	Filter with gasket for sample gas	A5E00248845
⑤	Filter, complete (for sample gas inlet, 6 mm)	A5E00295928
	Filter, complete (for sample gas inlet, 1/4")	A5E00295976
⑥	Cable, RS485	A5E00284100
⑦	Cable, connecting cable FIDAMAT 6	A5E00284096
⑧	Cable, connecting cable FIDAMAT 6	A5E00284095
⑨	Cable, measurement cable FIDAMAT 6	A5E00284094
⑩	Cable, RS232 interface	A5E00284087
⑪	Cable, heater for oven 115 V, screw terminal PIN 2 and 3 not connected	A5E00295469
⑫	Cable, heater for oven 230 V terminal PIN 1 to 6 connected	A5E00283817
⑬	Cable, solenoid valve MV1 – MV4	A5E00283800
⑭	Cable, temperature sensor for analyzer part FIDAMAT 6	A5E00283780
⑮	Cable, temperature sensor for oven FIDAMAT 6	A5E00283770
⑯	Cable, polarization voltage	A5E00284092

Figure 10-5 Rear view

10.4 Device views with spare part numbers

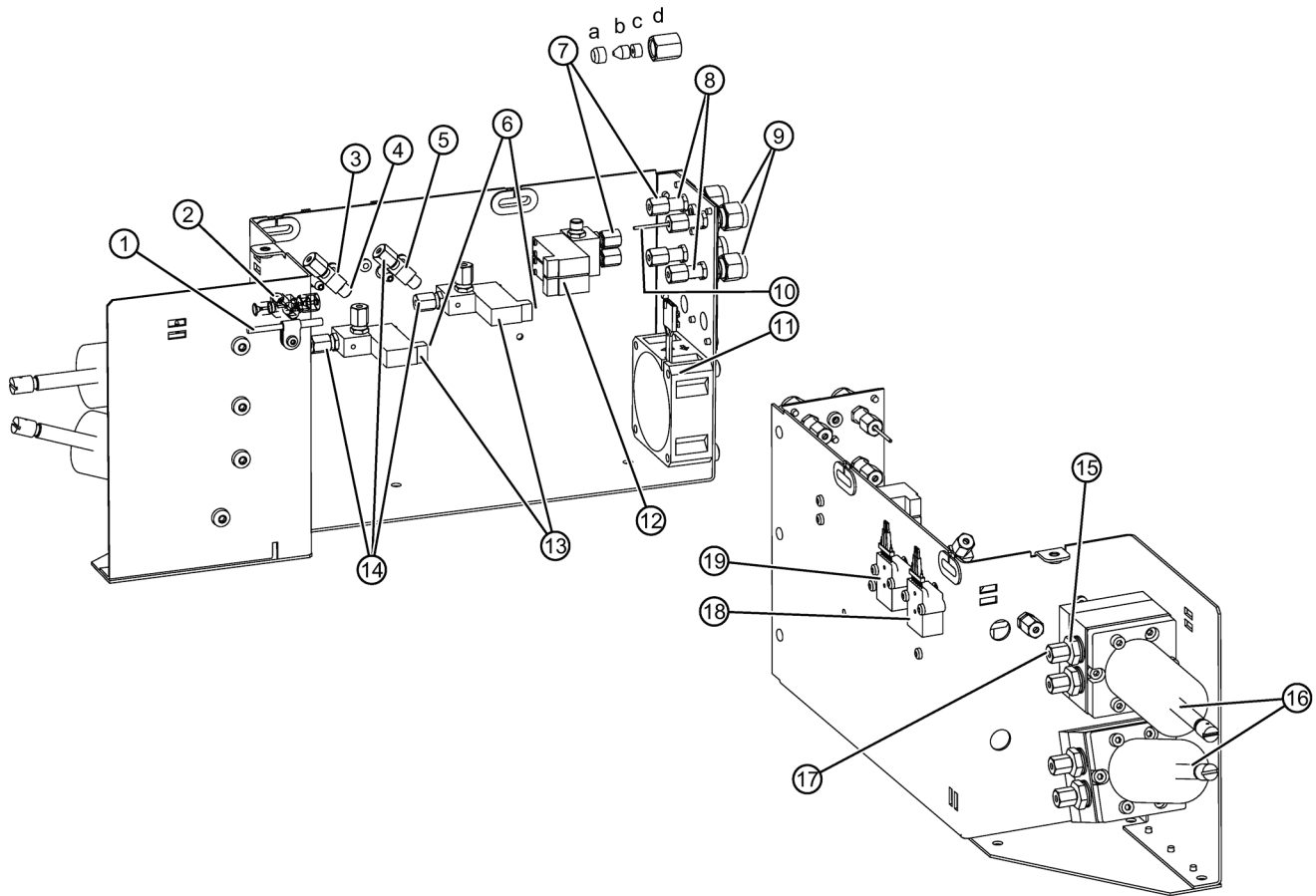

①	Cable, temperature sensor for analyzer part	A5E00283780
②	4-way distributor T9	A5E00296597
③	3-way distributor T8	A5E00296598
④	Outer ring	C79451-A3040-D122
	Gasket	C79451-A3040-D105
	Pressure ring	A5E00295333
	Union nut	C79451-A3040-D127
⑤	3-way distributor T7	A5E00296598
⑥	Cable, solenoid valve MV1-MV4 (not shown)	A5E00283800
⑦ ⑭ ⑰	Outer ring (a)	C79451-A3040-D122
	Gasket (b)	C79451-A3040-D101
	Pressure ring (c)	A5E00295333
	Union nut (d)	C79451-A3040-D127
⑧	Gas feed-through 6 mm connection	A5E00296560
	Gas feed-through 1/4" connection	A5E00296552
⑨	Set of unions 6 mm	A5E00313822
	Set of unions 1/4"	A5E00313831
⑩	Crimp restrictor DR8	A5E00296580
⑪	Axial fan	A5E00313839
⑫	2-way solenoid valve	A5E00296565



⑬	1-way solenoid valve	A5E00296562
⑭	see ⑦, is used for all non-labeled unions	
⑮	Gasket and fitting for pressure regulator	A5E00295107
⑯	Pressure regulator FIDAMAT 6	A5E00248851
⑰	see ⑦	
⑱	Pressure sensor 1 (combustion gas) with cable	A5E00284096
⑲	Pressure sensor 2 (combustion air) with cable	A5E00284095

Figure 10-6 Bulkhead

10.4 Device views with spare part numbers

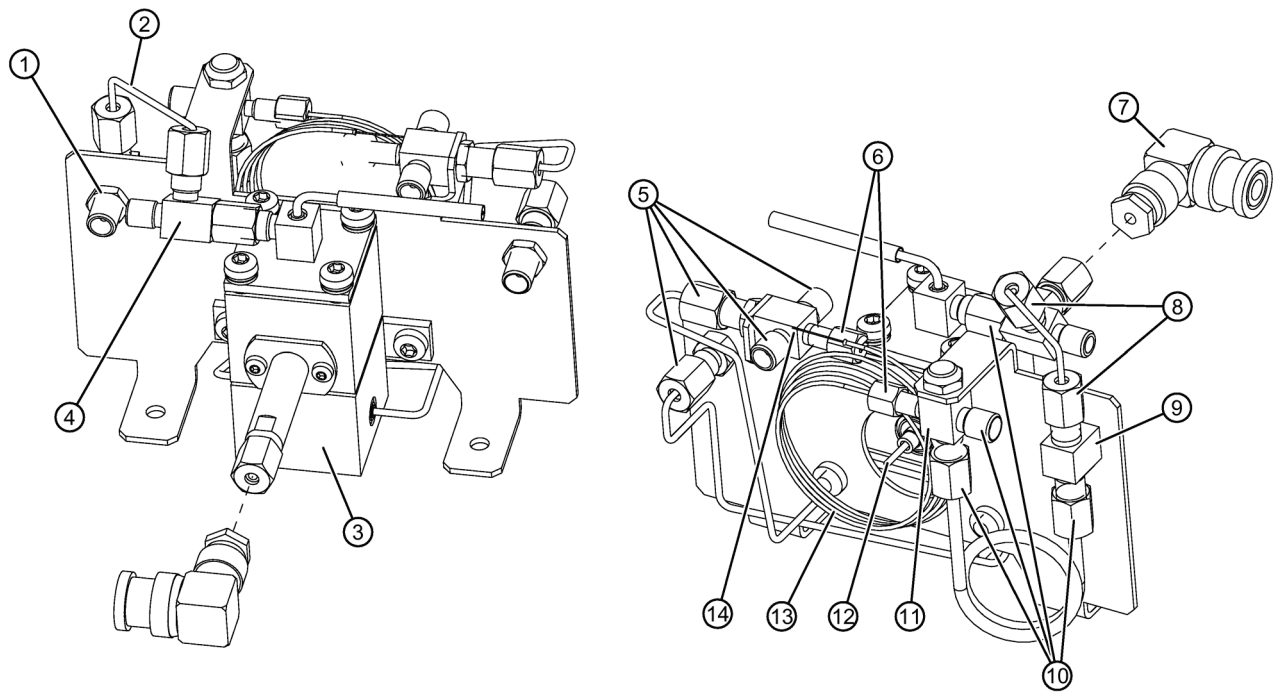

- |   |  |  |
|---|--|--|
| <p>① ⑩<br/>                 ②<br/>                 ③<br/>                 ④<br/>                 ⑤ ⑧<br/>                 ⑥<br/>                 ⑦<br/>                 ⑧<br/>                 ⑨<br/>                 ⑩<br/>                 ⑪<br/>                 ⑫<br/>                 ⑬<br/>                 ⑭</p> | <p>Outer ring<br/>                 Gasket<br/>                 Pressure ring<br/>                 Union nut<br/>                 Crimp restrictor DR4<br/>                 FI detector, complete<br/>                 3-way distributor T4<br/>                 Outer ring<br/>                 Gasket<br/>                 Pressure ring<br/>                 Union nut<br/>                 Outer ring<br/>                 Gasket<br/>                 Pressure ring<br/>                 Union nut<br/>                 Cable, measurement cable 230 V<br/>                 see ⑤<br/>                 3-way distributor T3<br/>                 see ①<br/>                 3-way distributor T2<br/>                 Cable, polarization voltage<br/>                 Restrictor line 4FS, complete DR6<br/>                 4-way distributor T1</p> | <p>C79451-A3040-D122<br/>                 C79451-A3040-D105<br/>                 A5E00295333<br/>                 C79451-A3040-D127<br/>                 A5E00296573<br/>                 A5E00295816<br/>                 A5E00296591<br/>                 C79451-A3040-D122<br/>                 C79451-A3040-D103<br/>                 A5E00295333<br/>                 C79451-A3040-D127<br/>                 C79451-A3040-D122<br/>                 C79451-A3040-D102<br/>                 A5E00295333<br/>                 C79451-A3040-D127<br/>                 A5E00284094<br/>                 A5E00296588<br/>                 A5E00296585<br/>                 A5E00284092<br/>                 A5E00296070<br/>                 A5E00296582</p> |
|---|--|--|

Figure 10-7 FID oven insert A5E00248859 FIDAMAT 6-E

## 10.4.2 Device views of FIDAMAT 6-G

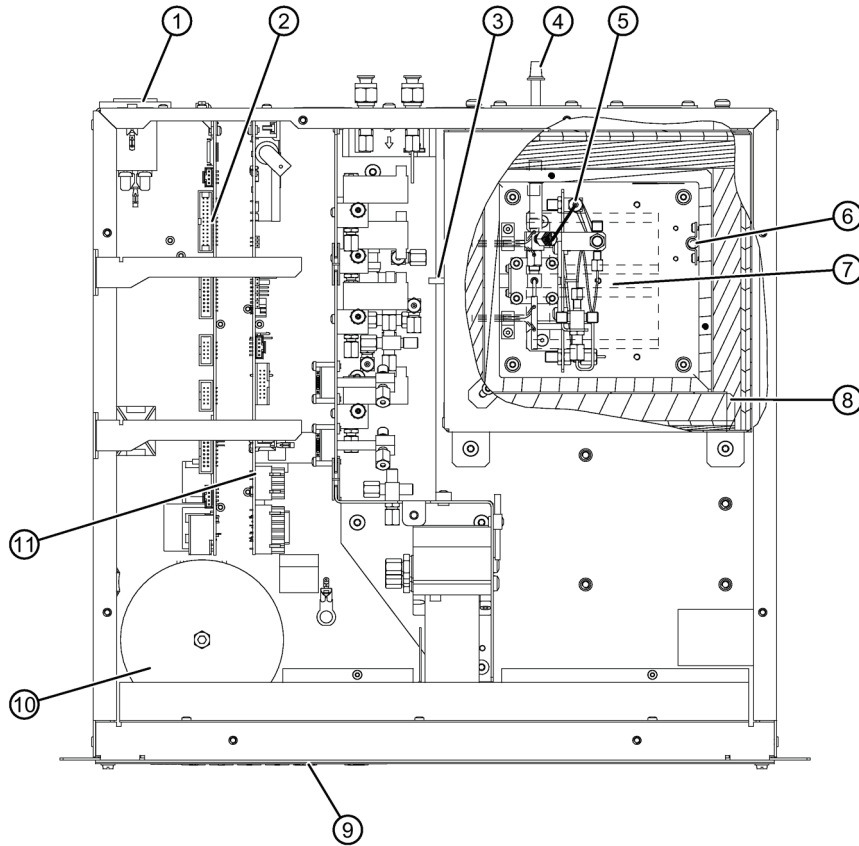

①	Device fuse 230V F 6	A5E00248819
	Device fuse 115V F 6	A5E00248822
②	Firmware FIDAMAT 6-G German	A5E00409885
	Firmware FIDAMAT 6-G English	A5E00409929
	Firmware FIDAMAT 6-G French	A5E00409947
	Firmware FIDAMAT 6-G Spanish	A5E00409962
	Firmware FIDAMAT 6-G Italian	A5E00409966
	Motherboard with firmware FIDAMAT 6-G German	A5E00410267
	Motherboard with firmware FIDAMAT 6-G English	A5E00410309
	Motherboard with firmware FIDAMAT 6-G French	A5E00410321
	Motherboard with firmware FIDAMAT 6-G Spanish	A5E00410324
	Motherboard with firmware FIDAMAT 6-G Italian	A5E00410326

10.4 Device views with spare part numbers

③	Cable, temperature sensor for oven F 6	A5E00283770
④	Gas exhaust 6 mm	A5E00299845
	Gas exhaust 1/4"	A5E00299847
⑤	FID oven insert FIDAMAT 6-G	A5E00429789
⑥	Thermal cut-out	A5E01040317
⑦	Cable, heater for oven 230 V	A5E00283817
	Cable, heater for oven 115 V	A5E00295469
⑧	Oven complete without analyzer part	A5E00434086
⑨	Front panel FIDAMAT 6	A5E00248790
	LCD display FIDAMAT 6	A5E31474846
⑩	Transformer 115 V	A5E00308869
	Transformer 230 V	A5E00308871
⑪	Adapter board FIDAMAT 6	A5E00248795
	Read-only memory FIDAMAT 6	A5E00299353

Figure 10-8 Top view

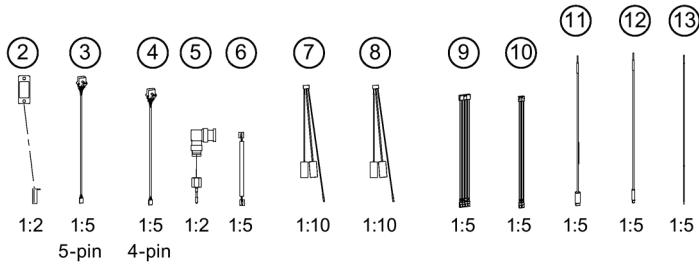
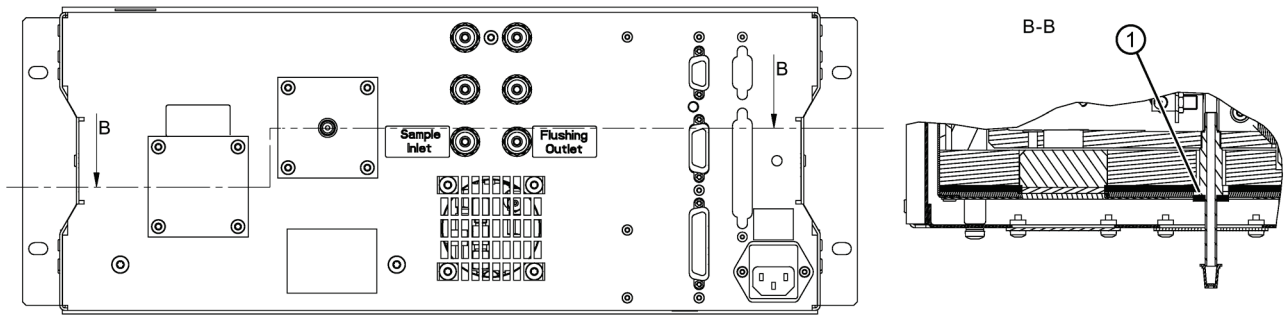

①	Sample gas outlet insulation	A5E00297369
②	Cable, RS485	A5E00284100
③	Cable, connecting cable FIDAMAT 6	A5E00284096
④	Cable, connecting cable FIDAMAT 6	A5E00284095
⑤	Cable, measurement cable FIDAMAT 6	A5E00284094
⑥	Cable, RS232 interface	A5E00284087
⑦	Cable, heater for oven 115 V, screw terminal PIN 2 and 3 not connected	A5E00295469
⑧	Cable, heater for oven 230 V terminal PIN 1 to 6 connected	A5E00283817
⑨	Cable, solenoid valve MV1-MV4	A5E00283800
⑩	Cable, solenoid valve MV5-MV6	A5E00422610
⑪	Cable, temperature sensor for analyzer part FIDAMAT 6	A5E00283780
⑫	Cable, temperature sensor for oven FIDAMAT 6	A5E00283770
⑬	Cable, polarization voltage	A5E00284092

Figure 10-9 Rear view

10.4 Device views with spare part numbers

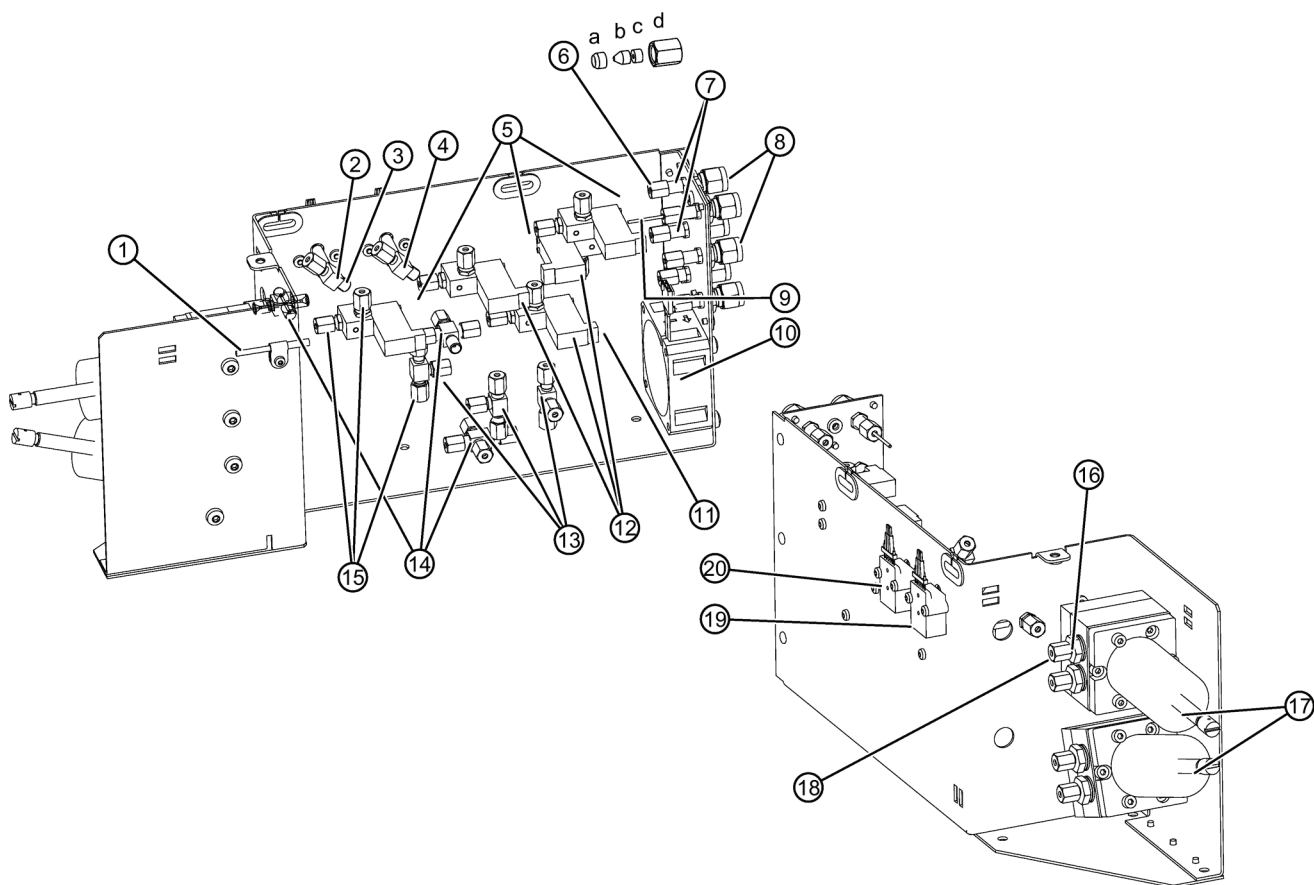

①	Cable, temperature sensor for analyzer part	A5E00283780
②	3-way distributor T8	A5E00296598
③	Outer ring	C79451-A3040-D122
	Gasket	C79451-A3040-D105
	Pressure ring	A5E00295333
	Union nut	C79451-A3040-D127
④	3-way distributor T7	A5E00296598
⑤	Cable, solenoid valve MV1-MV4 (not shown)	A5E00283800
⑥ ⑮ ⑱	Outer ring (a)	C79451-A3040-D122
	Gasket (b)	C79451-A3040-D101
	Pressure ring (c)	A5E00295333
	Union nut (d)	C79451-A3040-D127
⑦	Gas feed-through 6 mm connection	A5E00296560
	Gas feed-through 1/4" connection	A5E00296552
⑧	Set of unions 6 mm	A5E00313822
	Set of unions 1/4"	A5E00313831
⑨	Crimp restrictor DR8	A5E00296580
⑩	Axial fan	A5E00313839
⑪	Cable, solenoid valve MV5-MV6 (not shown)	A5E00422610
⑫	1-way solenoid valve	A5E00296562

⑬	3-way distributor T10/ T11/ T12	A5E00417431
⑭	4-way distributor T6/ T9/ T13	A5E00296597
⑮	see ⑥, is used for all non-labeled unions	
⑯	Gasket and fitting for pressure regulator	A5E00295107
⑰	Pressure regulator FIDAMAT 6	A5E00248851
⑱	see ⑥	
⑲	Pressure sensor 1 (combustion gas) with cable	A5E00284096
⑳	Pressure sensor 2 (combustion air) with cable	A5E00284095

Figure 10-10 Bulkhead

10.4 Device views with spare part numbers

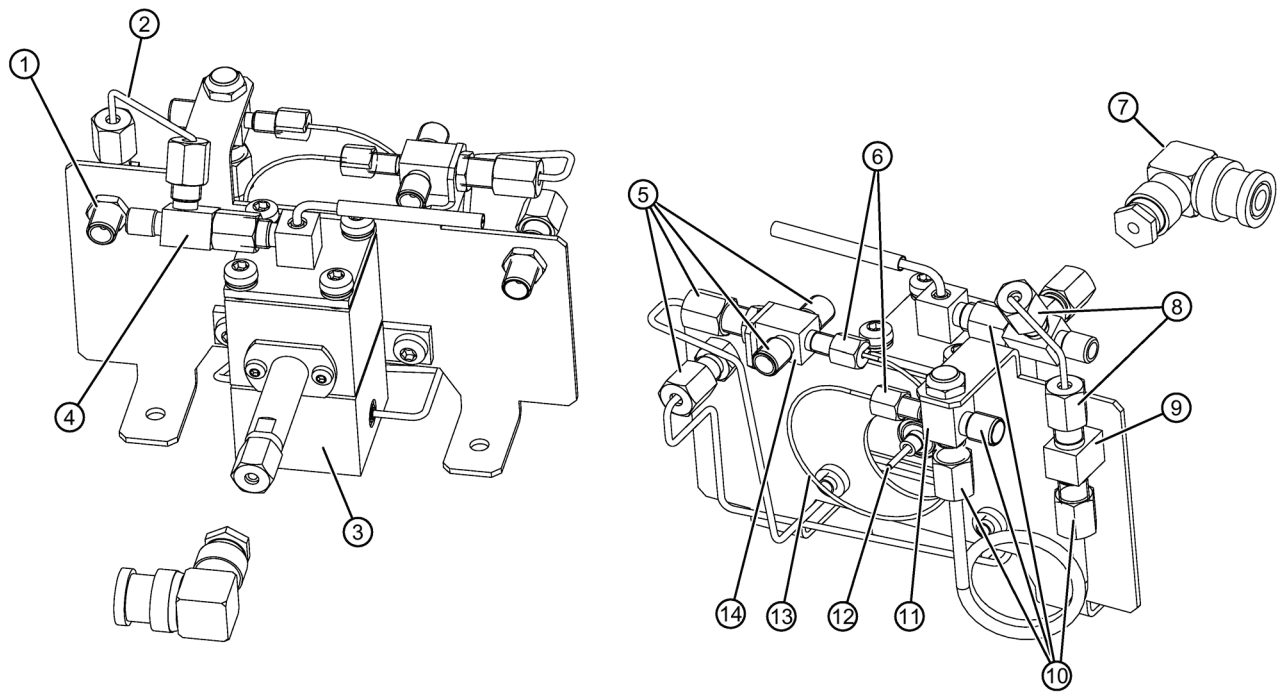

- |  |   |
|--|---|
| <p>① ⑩<br/>Outer ring<br/>Gasket<br/>Pressure ring<br/>Union nut</p> <p>②<br/>Crimp restrictor DR4</p> <p>③<br/>FI detector, complete</p> <p>④<br/>3-way distributor T4</p> <p>⑤ ⑧<br/>Outer ring<br/>Gasket<br/>Pressure ring<br/>Union nut</p> <p>⑥<br/>Outer ring<br/>Gasket<br/>Pressure ring<br/>Union nut</p> <p>⑦<br/>Cable, measurement cable 230 V</p> <p>⑧<br/>see ⑤</p> <p>⑨<br/>3-way distributor T3</p> <p>⑩<br/>see ①</p> <p>⑪<br/>3-way distributor T2</p> <p>⑫<br/>Cable, polarization voltage</p> <p>⑬<br/>Crimp restrictor, restrictor line 1FS, complete DR13</p> <p>⑭<br/>4-way distributor T1</p> | <p>C79451-A3040-D122<br/>C79451-A3040-D105<br/>A5E00295333<br/>C79451-A3040-D127<br/>A5E00296573<br/>A5E00295816<br/>A5E00296591</p> <p>C79451-A3040-D122<br/>C79451-A3040-D103<br/>A5E00295333<br/>C79451-A3040-D127<br/>C79451-A3040-D122<br/>C79451-A3040-D102<br/>A5E00295333<br/>C79451-A3040-D127<br/>A5E00284094</p> <p>A5E00296588</p> <p>A5E00296585<br/>A5E00284092<br/>A5E00417394<br/>A5E00296582</p> |
|--|---|

Figure 10-11 FID oven insert A5E00429789 FIDAMAT 6-G



## Technical specifications

### 11.1 General technical data of the FIDAMAT 6 gas analyzers

Table 11- 1 Technical specifications – Design, housing

<b>Design, enclosure</b>	
Degree of protection	IP20 according to EN 60529 IP40 after installation in analyzer cabinet (FIDAMAT Analyzer System)
Dimensions	See section "Dimension drawings and circuit diagrams" (Page 173)
Weight	approx. 23 kg (51 lbs.)

Table 11- 2 Technical specifications – Electric characteristics

<b>Electrical characteristics</b>	
Auxiliary power supply	100 to 120 V AC (nominal range of use 90 V to 132 V), 48 to 63 Hz or 200 to 240 V AC (nominal range of use 180 V to 264 V), 48 to 63 Hz
Power consumption	Approx. 150 VA during operation Approx. 350 VA in the warm-up phase
EMC interference immunity (electromagnetic compatibility)	In accordance with standard requirements of NAMUR NE21 (08/98)
Electrical safety	In accordance with EN 61010-1, Overvoltage category II
Fuse values	100 to 120 V: 4.0 T/250 200 to 240 V: 2.5 T/250

Table 11- 3 Technical specifications – Gas consumption data

<b>Gas consumption data</b>	
Combustion air	Approx. 350 ml/min
Hydrogen	Approx. 12 ml/min
Sample gas	Approx. 1 l/min
Zero gas/ calibration gas	Approx. 1.5 l/min

Table 11- 4 Technical specifications – Time response

<b>Time response</b>	
Warm-up time (until ready for measurement)	Approx. 3 h at room temperature
Display delay (T90)	2-3 s

## Technical specifications

### 11.1 General technical data of the FIDAMAT 6 gas analyzers

<b>Time response</b>	
Damping (electrical time constant)	0-100 s, can be configured
Dead time (purging time of the gas path in the device at a flow of 1 l/min)	2-3 s
Time for device-internal signal processing	< 1 s

Table 11- 5 Technical specifications – Measuring characteristics

<b>Measuring characteristics</b> (with respect to a measuring gas pressure of 1013 hPa absolute, sample gas flow of 0.5 l/min and an ambient temperature of 25 °C)	
Output signal fluctuations	< 0.75% of smallest possible measuring range according to rating plate with electronic damping constant of 1 s (this corresponds to +/- 0.25% at 2 $\sigma$ )
Zero point drift	< 0.5% /month of the smallest possible span according to rating plate
Measured value drift	< 1% /week of smallest possible span according to rating plate
Repeatability	< 1% of smallest possible span according to rating plate
Linearity deviation	< 1% of smallest possible span according to rating plate

Table 11- 6 Technical specifications – Influencing variables

<b>Influencing variables</b> (with respect to a measuring gas pressure of 1013 hPa absolute, sample gas flow of 0.5 l/min and an ambient temperature of 25 °C)	
Ambient temperature	< 1% / 10 K with respect to the smallest span according to rating plate
Ambient pressure	< 1% /50 hPa
Sample gas pressure	< 2% of span /1% change in pressure
Auxiliary power supply	< 1% when the output signal span changes by $\pm 10\%$
Frequency	< 1%
Position influence	< 1% for inclination < 15°

Table 11- 7 Technical specifications – Electrical inputs and outputs

<b>Electrical inputs and outputs</b>	
Analog output	0/ 2/ 4 to 20 mA, floating, max. load impedance 750 $\Omega$
Relay outputs	6, with changeover contacts, user-configurable, e.g. for measuring range identification; max. load: 24 V AC/DC / 1 A, floating
Analog inputs	2, designed for 0/ 2/ 4 to 20 mA for external pressure sensor and auxiliary gas correction (correction of cross-interference)
Binary inputs	6, designed for 24 V, floating, user-configurable, e.g. for measuring range switching
Serial interface	ELAN (RS 485)
Options	Autocal function with 8 additional binary inputs and eight additional relay outputs, also with PROFIBUS PA or PROFIBUS DP

Table 11- 8 Technical specifications – Climatic conditions

<b>Climatic conditions</b>	
Permissible ambient temperature	+5 °C to +45 °C (41 °F to 113 °F) during operation as a single device +5 °C to +40 °C (41 °F to 104 °F) during operation in analysis cabinets -30 °C to +70 °C (-22 °F to 158 °F) during storage and transport;
Permissible humidity	< 90% relative humidity annual average, during storage and shipping (dropping below dew point not permissible)

## 11.2 Technical specifications of the FIDAMAT 6-E

Table 11- 9 Technical specifications – General

<b>General</b>	
Measuring ranges	4, internally and externally switchable; manual and automatic measuring range switchover possible
Automatic measuring range switchover	Hysteresis, selectable
Smallest possible span	0 ... 10 ppm
Detection limit	0.1 ppm
Largest possible span	99999 ppm
Concentration units	ppm C1, ppm C3, ppm C6, mg C/m <sup>3</sup>
Measured value display	Digital concentration display (5 digits with floating decimal point)
Resolution of digital display	0.1% of measured value
Operating position	Front panel vertical
Oven temperature	Can be set between 100 and 200 °C (212 and 392 °F), application-dependent

Table 11- 10 Technical specifications – Gas inlet conditions

<b>Gas inlet conditions</b>	
Sample gas pressure	600 ... 1100 hPa
Sample gas flow rate	Approx. 1 l/min (60 l/h)
Sample gas temperature	0 ... 200 °C (32 ... 392 °F)
Sample gas humidity	< 90% relative humidity

11.3 Technical data of the FIDAMAT 6-G

Table 11- 11 Technical specifications – Pressures and flow

<b>Pressures and flow</b>					
<b>Gases</b>	<b>Inlet pressure hPa (rel.)</b>	<b>Operating pressure hPa (rel.)</b>		<b>Flow through FID ml/min</b>	<b>Flow through by-pass ml/min</b>
		<b>Without pump start-up</b>	<b>With pump start-up</b>		
Combustion gas	2000 ... 4000		1000 ± 20	~ 12	-
Combustion air	2000 ... 4000	420 ± 20	500	~ 320	~ 500
Sample gas	atmospheric	-	500 ± 2	~ 3	~ 1000
Zero gas	2500 ... 3000	-	500 ± 2	~ 3	~ 1000
Calibration gas	2500 ... 3000	-	500 ± 2	~ 3	~ 1000

## 11.3 Technical data of the FIDAMAT 6-G

Table 11- 12 Technical specifications – General

<b>General</b>	
Measuring ranges	4, internally and externally switchable; manual and automatic measuring range switchover possible
Automatic measuring range switchover	Hysteresis, selectable
Smallest possible span	0-10 ppm
Detection limit	0.03 ppm
Largest possible span	99.999 ppm
Concentration units (ppm)	C1, C3, C6, mg C/m <sup>3</sup>
Measured value display	Digital concentration display (5 digits with floating decimal point)
Resolution of digital display	0.1% of measured value
Operating position	Front panel vertical
Conformity	CE marking EN 50081-1, EN 50082-2
Oven temperature	Adjustable between 100 and 200 °C (depending on application)

Table 11- 13 Technical specifications – Gas inlet conditions

<b>Gas inlet conditions</b>	
Permissible sample gas pressure	Approx. 1,000 hPa
Sample gas flow rate	18 to 60 l/h (0.3 to 1 l/min)
Sample gas temperature	0-200 °C
Sample gas humidity	< 90% relative humidity

Table 11- 14 Technical specifications – Pressures and flow

<b>Pressures and flow</b>				
<b>Gases</b>	<b>Inlet pressure hPa (rel.)</b>	<b>Operating pressure hPa (rel.)</b>	<b>Flow through FID ml/min</b>	<b>Flow through bypass ml/min</b>
Combustion gas	2,000 – 4,000	1,000 ± 20	~ 25	-
Combustion air	2,000 – 4,000	475 ± 5	~ 320	~ 500
Sample gas	800 – 1,000	-	~ 3	~ 1,000
Zero gas	800 – 1,000	-	~ 3	~ 1,000
Calibration gas	800 – 1,000	-	~ 3	~ 1,000



## Dimensional drawings

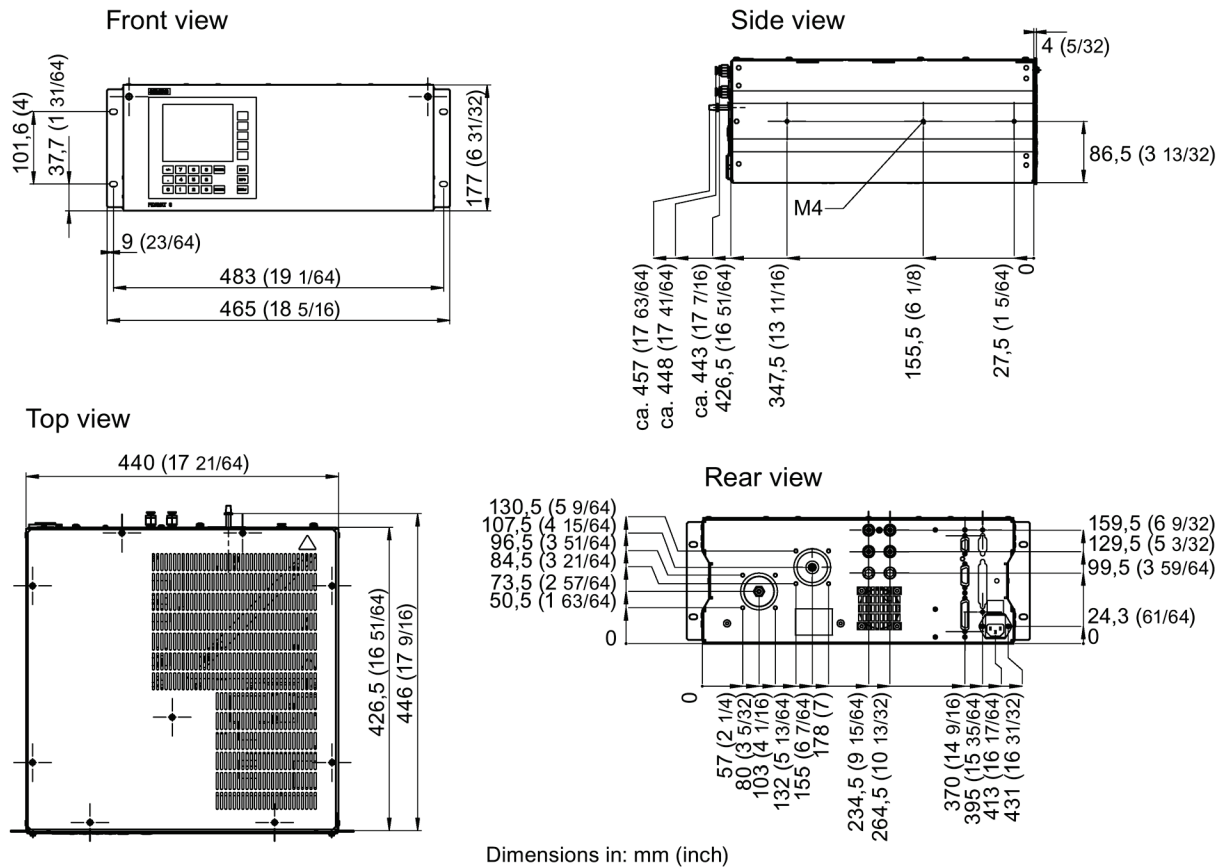

Figure 12-1 Dimension drawings of FIDAMAT 6





# Appendix

## A.1 Technical support

### Technical Support

If you have any technical questions, contact Technical Support (<https://support.industry.siemens.com/cs/ww/en/sc/2090>).

Use our online request form Support Request (<https://support.industry.siemens.com/My/ww/en/requests#createRequest>).

### Service & Support on the Internet

In addition to our documentation, we offer further information online on the Internet:

Industry Online Support (<https://support.industry.siemens.com/cs/ww/en/sc>)

There you will find:

- The latest product information, FAQs, downloads, tips and tricks.
- A newsletter that provides you with up-to-date information about the products.
- The Knowledge Manager that finds the right documents for you.
- Your local contact partner for automation technology in our contacts database.
- Information about on-site services, repairs, spare parts and much more is available on our "Services" pages.

Our bulletin board, where users and specialists share their knowledge worldwide.

### Additional Support

Contact your local Siemens partner if you have any questions about the use of products described in this manual and cannot find the answers here.

Find your contact partner at:

Partner (<https://www.automation.siemens.com/partner>)

A signpost to the documentation of the various products and systems is available at:

Instructions and Manuals (<https://support.industry.siemens.com/cs/ww/en/ps/17731/man>)

## A.2 Return procedure

The device has to be returned in its original packaging. If the original packaging is no longer available, return the device in appropriate packaging.

Include the delivery note, the goods document with the returned goods process mark and decontamination certificate in a firmly attached clear plastic pouch on the outside of the packaging.

With this decontamination declaration you warrant that the device/replacement part has been carefully cleaned and is free of residues. The device/replacement part does not pose a hazard for humans and the environment. If the returned device/replacement part has come into contact with poisonous, corrosive, flammable or water-polluting substances, you must thoroughly clean the device/replacement part before returning it, in order to ensure that all hollow areas are free of hazardous substances. Check the item after it has been cleaned. Devices/replacement parts without decontamination certificate will be returned to you at your expense.

The forms are available on the supplied CD.

For more detailed information, refer to Return procedure (<https://support.industry.siemens.com/cs/ww/en/sc/4529>)

## A.3 ESD guidelines

### Definition of ESD

All electronic modules are equipped with large-scale integrated ICs or components. Due to their design, these electronic elements are highly sensitive to overvoltage, and thus to any electrostatic discharge.

The electrostatic sensitive components/modules are commonly referred to as ESD devices. This is also the international abbreviation for such devices.

ESD modules are identified by the following symbol:



**NOTICE**

ESD devices can be destroyed by voltages well below the threshold of human perception. These static voltages develop when you touch a component or electrical connection of a device without having drained the static charges present on your body. The electrostatic discharge current may lead to latent failure of a module, that is, this damage may not be significant immediately, but in operation may cause malfunction.

**Electrostatic charging**

Anyone who is not connected to the electrical potential of their surroundings can be electrostatically charged.

The figure below shows the maximum electrostatic voltage which may build up on a person coming into contact with the materials indicated. These values correspond to IEC 801-2 specifications.

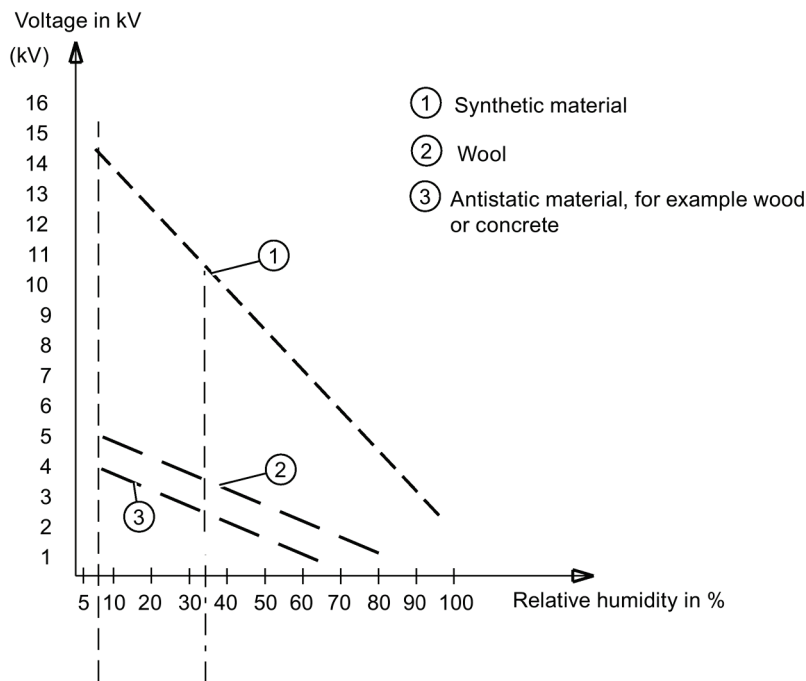

Figure A-1 Electrostatic voltages on an operator

**Basic protective measures against electrostatic discharge**

- Ensure good equipotential bonding:  
When handling electrostatic sensitive devices, ensure that your body, the workplace and packaging are grounded. This prevents electrostatic charge.
- Avoid direct contact:  
As a general rule, only touch electrostatic sensitive devices when this is unavoidable (e.g.

during maintenance work). Handle the modules without touching any chip pins or PCB traces. In this way, the discharged energy can not affect the sensitive devices.

Discharge your body before you start taking any measurements on a module. Do so by touching grounded metallic parts. Always use grounded measuring instruments.

## A.4 Overview of operating functions

The device functions are listed in the following overview. This list corresponds to software version V1.3.6.

Table A- 1 Overview of operator control functions

Submenu	Function	Name of function
Analyzer status	1	Analyzer configuration
	2	Diagnostic values
	3	Logbook
	4	Display meas. ranges
Calibration (code 1)	20	Zero calibration
	21	Span calibration
	22	Setpoints for zero/ span
	23	Calibration settings (single/total range calibration)
	24	AUTOCAL/-check (only with option board)
25	Drift values	
Measuring ranges (code 1)	40	Range selection
	41	Define meas. ranges
Parameters (code 1)	50	El. time constants
	51	Limits
	52	On/off configuration
	53	Status messages
	54	G. signal display
	55	Select digits
	56	LCD contrast
	57	Ignite flame
	58	Date/Time
	59	Sample selection
	60	Setup logbook
	61	Int. valves
	62	Adjust external pressure (FIDAMAT 6-G only)
Configuration (code 2)	70	Analog output
	71	Relay assignment
	72	Binary inputs
	73	ELAN configuration
	74	Reset

Submenu	Function	Name of function
	75	Save data, load
	76	Suppress fault
	77	Analog output memory
	78	Calib. tolerance
	79	Change codes
	80	Analyzer test
	81	Select language
	83	Interfer. correct.
	85	Switch valves
	86	Lin. temp. comp.
	87	Error On/Off
	90	PROFIBUS config. (only with option board)
	91	Start-up state (operating states)
	92	Pressure values
	93	Dimension
	99	Factory settings

## A.5 Wiring diagrams

### A.5.1 Motherboard pin assignments

Connector D-SUB 9F (RS 485)

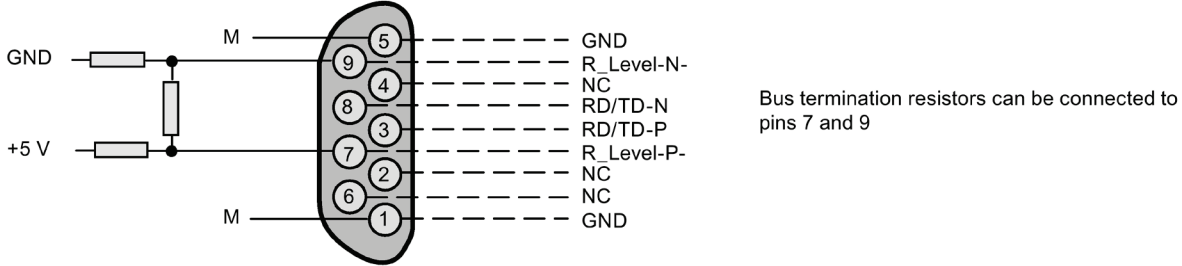

Connector D-SUB 15F

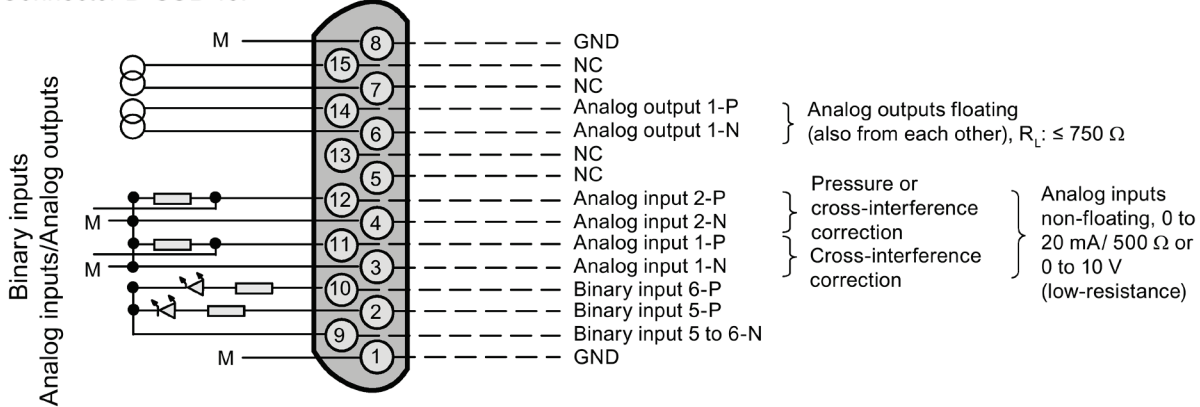

Connector D-SUB 25F

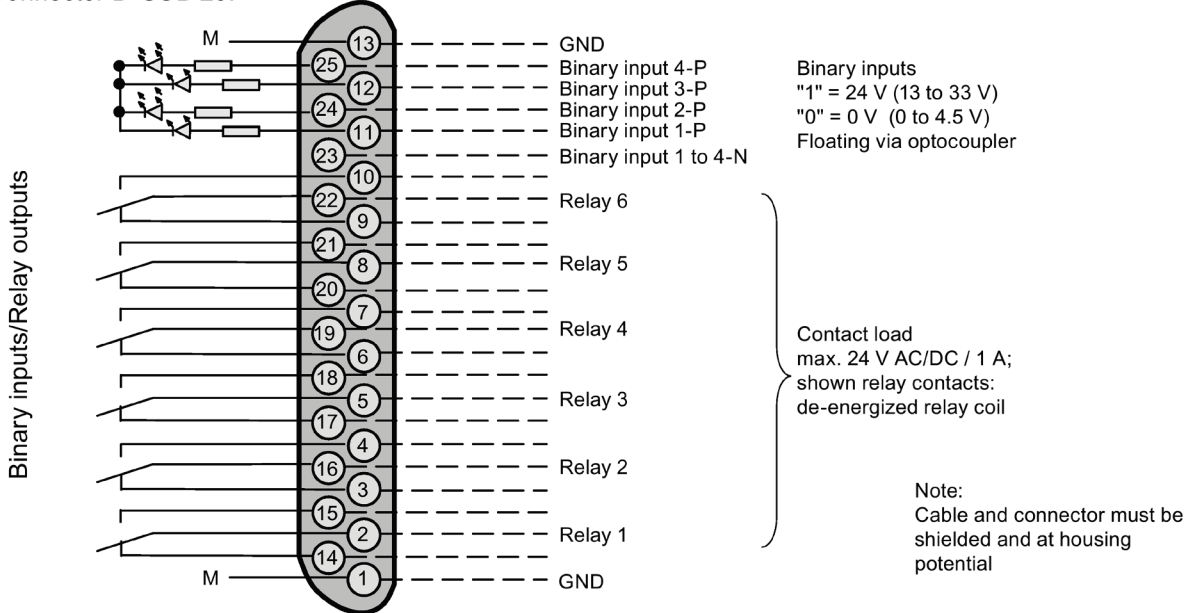
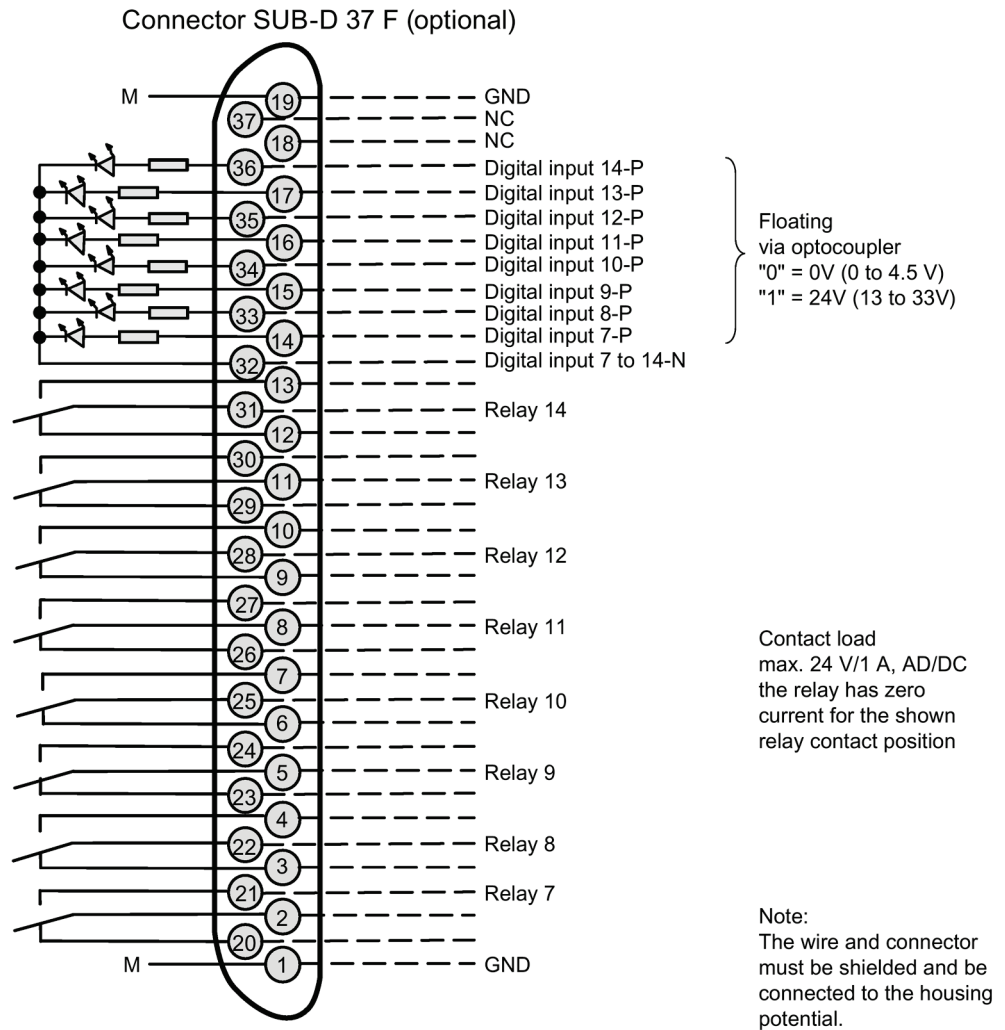
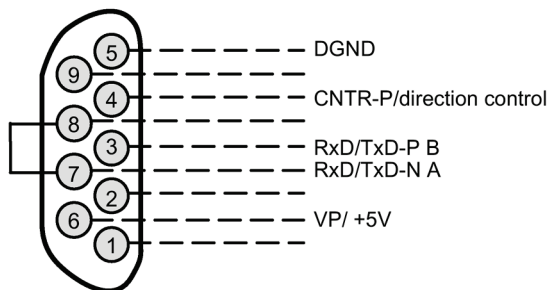

Figure A-2 Motherboard pin assignment

### A.5.2 Plug connector assignment of the optional board and PROFIBUS



Connector SUB-D 9F-X90  
 PROFIBUS DP      Optional



Connector SUB-D 9M-X90  
 PROFIBUS PA

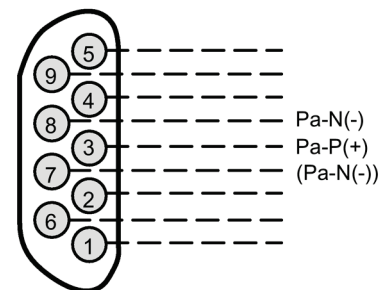
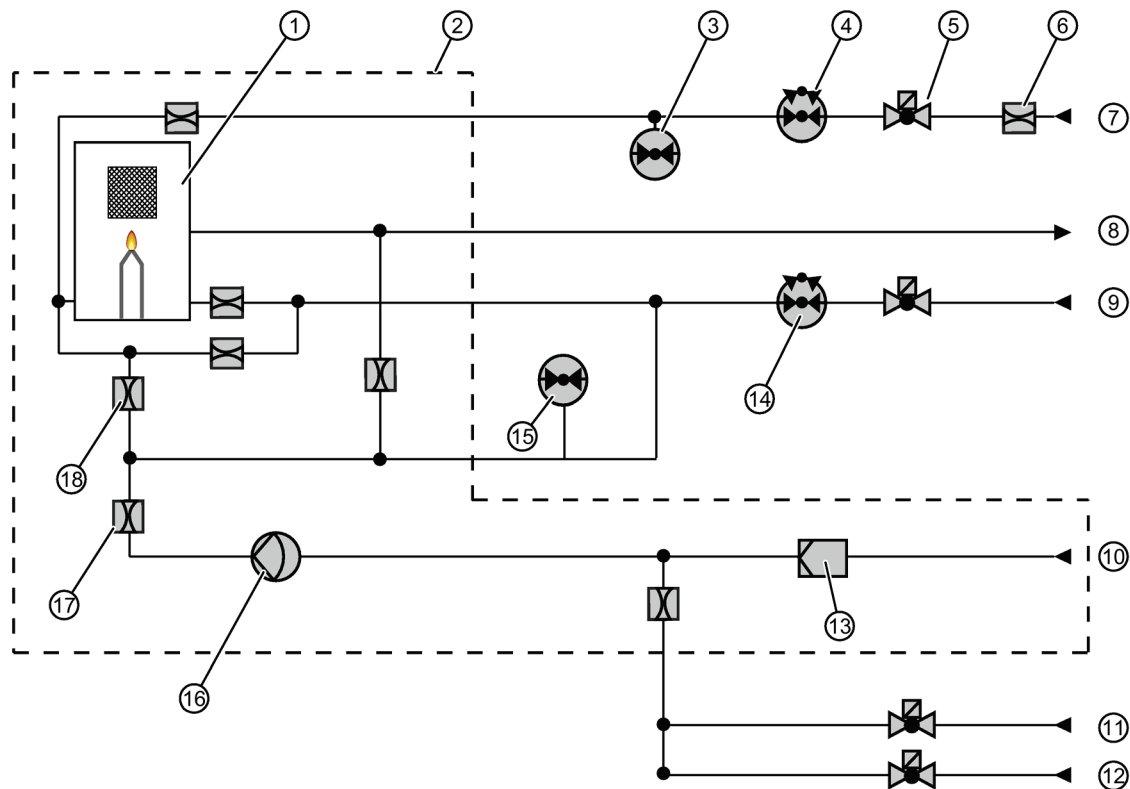

Figure A-3 Pin assignment of the option board and PROFIBUS connector, 19" rack unit

### A.5.3 Gas flow of the FIDAMAT 6-E



- |                                 |                                 |
|---------------------------------|---------------------------------|
| ① Sample chamber                | ⑩ Sample gas                    |
| ② Heated oven                   | ⑪ Zero gas                      |
| ③ Pressure sensor               | ⑫ Calibration gas               |
| ④ Mechanical pressure regulator | ⑬ Filter                        |
| ⑤ Solenoid valve                | ⑭ Mechanical pressure regulator |
| ⑥ Restrictor                    | ⑮ Pressure sensor               |
| ⑦ Combustion gas H <sub>2</sub> | ⑯ Pump                          |
| ⑧ Gas exhaust                   | ⑰ Damping                       |
| ⑨ Combustion air                | ⑱ Restrictor                    |

Figure A-4 Gas flow FIDAMAT 6-E



### A.5.4 Gas flow of the FIDAMAT 6-G

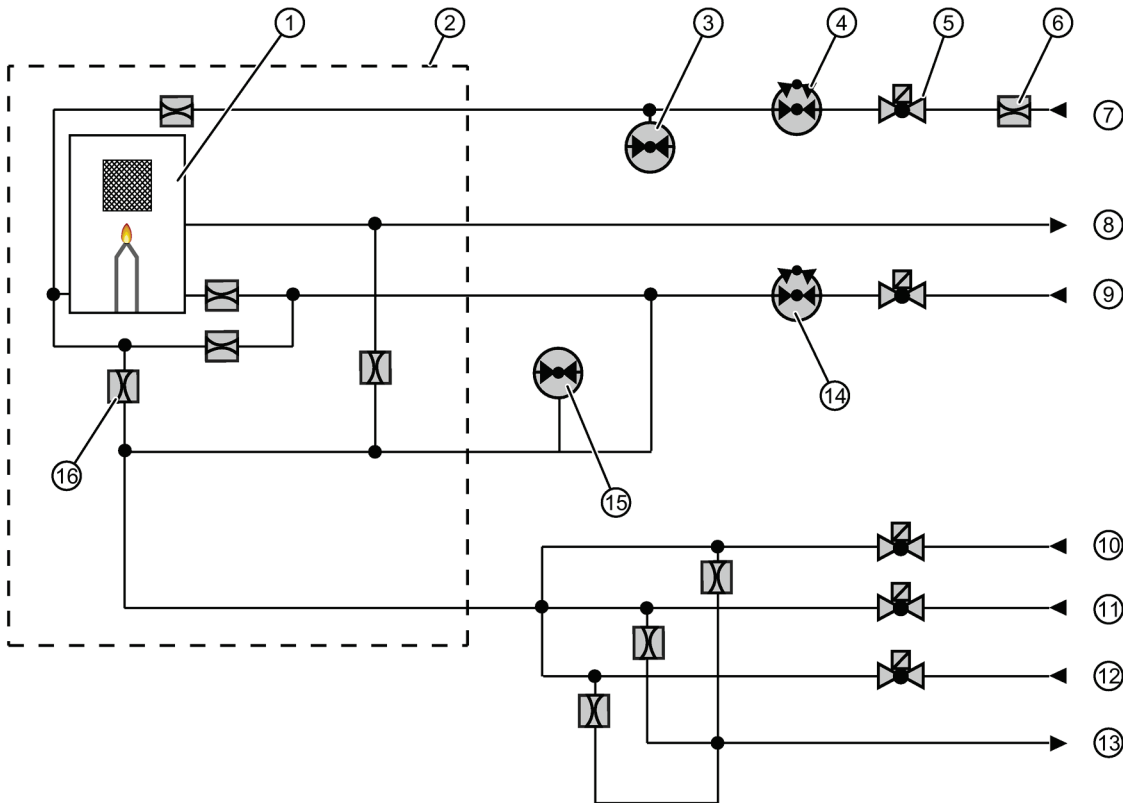

- |                                 |                                 |
|---------------------------------|---------------------------------|
| ① Sample chamber                | ⑨ Combustion air                |
| ② Heated oven                   | ⑩ Sample gas                    |
| ③ Pressure sensor               | ⑪ Zero gas                      |
| ④ Mechanical pressure regulator | ⑫ Calibration gas               |
| ⑤ Solenoid valve                | ⑬ Flushing outlet               |
| ⑥ Restrictor                    | ⑭ Mechanical pressure regulator |
| ⑦ Combustion gas H <sub>2</sub> | ⑮ Pressure sensor               |
| ⑧ Gas exhaust                   | ⑯ Restrictor                    |

Figure A-5 Gas flow FIDAMAT 6-G



## List of abbreviations

### B.1 List of abbreviations

Abbreviation/symbol	Explanation
"	Inch 1" = 25.4 mm
<	Less than
>	Greater than
≤	Less than or equal to
≥	Greater than or equal to
±	Plus or minus
%	Percent
vol%	Volume percent
°	Degrees
°C	Degrees Celsius; $n\text{ }^{\circ}\text{C} = (n\text{ }^{\circ}\text{F} - 32) / 1.8$
°F	Degrees Fahrenheit; $n\text{ }^{\circ}\text{F} = n\text{ }^{\circ}\text{C} \times 1.8 + 32$
A	Ampere
sec.	Section
AC	Alternate Current
OEL	Occupational Exposure Limit
AK interface	In this case: Interface for connection/communication in the automotive industry
AUTOCAL	Automatic calibration function, derived from <b>AUTOMATIC CALIBRATION</b>
AWG	American Wire Gauge,, standard for cross-sections of cables
BImSchV	<b>Bundesimmissionsschutzverordnung</b> (German Federal Emission Protection Directive)
CD	Compact Disk, a storage medium
CE	Communauté Européenne (French for European Community)
cm <sup>2</sup>	Square centimeter
CS <sub>2</sub>	Chem. formula for carbon dioxide
COM	<b>common</b>
CrNi	<b>Chrome-Nickel</b> (steel)
dB	<b>Decibel</b>
DC	<b>Direct Current</b>
DIN	<b>Deutsches Institut für Normung</b> - German institute for standardization
DP	<b>Distributed Peripherals</b>
D-SUB; D-Sub	<b>D-shaped sub</b> -miniature connector
EEPROM	<b>Electrically Erasable Programmable Read Only Memory</b>
EC	<b>European Community</b>

Abbreviation/symbol	Explanation
ESD	<b>E</b> lectrostatically <b>S</b> ensitive <b>D</b> evice
EU	<b>E</b> uropean <b>U</b> nion
ELAN	<b>E</b> conomic <b>L</b> ocal <b>A</b> rea <b>N</b> etwork, a data network
EMC	<b>E</b> lectro <b>M</b> agnetic <b>C</b> ompatibility
EN	<b>E</b> uropäische <b>N</b> orm (European standard)
ESD	<b>E</b> lectrostatic <b>D</b> ischarge
ext.	<b>e</b> xternal
EPROM	<b>E</b> rasable <b>P</b> rogrammable <b>R</b> ead <b>O</b> nly <b>M</b> emory
F.-No.; Fab. No.	Serial Number
FID	<b>F</b> lame <b>I</b> onization <b>D</b> etector
GND	(Chassis) <b>G</b> round
h	Hour
H <sub>2</sub>	Chem. formula for hydrogen
U	Height unit for computer housing, 1 U = 1¾" = 44.45 mm
hPa	<b>H</b> ecto <b>p</b> ascal
Hyst	<b>H</b> ysteresis
IEC	<b>I</b> nternational <b>E</b> lectrotechnical <b>C</b> ommission
IP	<b>I</b> nternal <b>P</b> rotection
kHz	<b>k</b> ilo <b>h</b> ertz
kΩ	<b>k</b> ilo <b>o</b> hm
l	liter
L	<b>L</b> ive wire
lb, lbs.	pound(s), 1 lb. $\triangleq$ 435.6 g
LCD	<b>L</b> iquid <b>C</b> rystal <b>D</b> isplay
LED	<b>L</b> ight <b>E</b> mitting <b>D</b> iode
M	<b>G</b> round
m	<b>m</b> eter
mA	<b>m</b> illi <b>a</b> mpere
MAK	Maximum workplace concentration, German occupational exposure limit
max.	<b>m</b> aximum
MB	<b>M</b> easuring <b>R</b> ange
MB	<b>M</b> bit = 10 <sup>6</sup> bits
mba, MBA	Measuring range start-of-scale value
mbar	<b>m</b> illib <b>a</b> r
mbe, MBE	Measuring range full-scale value
mg	<b>m</b> illig <b>r</b> am
MHz	<b>M</b> egahertz
min	<b>m</b> inute
MC	<b>M</b> easuring <b>c</b> omponent
ml	<b>m</b> illiliter
MLFB	Machine-readable Order No.

Abbreviation/symbol	Explanation
mm	millimeter
mm <sup>2</sup>	Square millimeter
SV	Solenoid valve
mΩ	milliohm
MΩ	Megaohm
NAMUR	Normenarbeitsgemeinschaft für Mess- und Regeltechnik in der chemischen Industrie (standardization body for instrumentation and control technology in the chemical industry)
n. g.	If required
NC	Not Connected
No.	Number
p	Symbol for pressure
O <sub>2</sub>	Chem. formula for oxygen
o. Ä.	Or similar
PA	Process Analytics
PC	Personal Computer
pF	picofarad (10 <sup>-12</sup> farad)
PNO	PROFIBUS-Nutzer-Organisation (PROFIBUS user organization)
ppb	parts per billion
ppm	parts per million
PROFIBUS	Process Field Bus, a standard for fieldbus communication
PTFE	Polytetrafluoroethylene, a plastic, tradename e.g. Teflon
QAL	Quality Assurance Level
RAM	Random Access Memory
rel.	relative
RJ 45	RJ = Registered Jack, standard plug connection for telecommunication cables
ROM	Read Only Memory
RS 232	(also EIA-232) Identifies an interface standard for a wired serial data transmission
RS 485	(also EIA-485) Identifies an interface standard for a wired differential, serial data transmission
RxD, RD	Received exchange Data
s	second
SIPROM GA	Siemens Process Maintenance for Gas Analyzers
SW	Software
t	Symbol for time
TA Luft	Technical Instructions on Air Quality Control (Germany)
TCP/IP	Transmission Control Protocol/Internet Protocol; a reference model for Internet communication
THC	Total hydrocarbons
TC	Temperature compensation
TÜV	Technischer Überwachungsverein, German Technical Inspectorate

*List of abbreviations*

*B.1 List of abbreviations*

<b>Abbreviation/symbol</b>	<b>Explanation</b>
TxD, TD	Transmitted exchange <b>D</b> ata
RPM	Revolutions Per <b>M</b> inute
USB	<b>U</b> niversal <b>S</b> erial <b>B</b> us
u. U.	under (certain) circumstances
V	<b>V</b> olt
V; V.	<b>V</b> ersion
VDE	<b>V</b> erband <b>d</b> er <b>E</b> lektrotechnik, <b>E</b> lektronik und <b>I</b> nformationstechnik (German Association for Electrical, Electronic and Information Technologies)
VGA	<b>V</b> ideo <b>G</b> raphics <b>A</b> rray, a computer graphics standard
vpm	<b>V</b> olume <b>p</b> arts per <b>m</b> illion
e. g.	<b>F</b> or <b>e</b> xample
$\Delta$	Difference (delta)
$\mu$ A	Microampere
$\mu$ m	Micrometer
$\Omega$	Ohm

# Glossary

## Adapter board

Board contained in the standard configuration of the FIDAMAT 6. It is used to preprocess sensor signals and the measured signal.

## Additional electronics

Generic term for all option boards.

## Autorange

Automatic switching between different measuring ranges. Also referred to as "autorange" in the software.

## Basic configuration

Totality of standard features contained in the device at the time of delivery without optional extensions.

## Calibrating

Elimination of deviations between the setpoint and actual value of certain measured variables.

## Calibration gas

Gas used to carry out a calibration.

## Code

Configurable string of characters for unlocking a protected submenu.

## Code level

Area of protected functions or states that are unlocked after entering a certain code.

## Coded display mode

Operating mode in which the measured value is displayed and the device is protected against unauthorized access by codes.

**Combustion air**

Gas mixture containing oxygen that is needed to form a flame (only burns in combination with combustion gas). In the FIDAMAT 6, synthetic air is used as combustion air.

**Combustion gas**

Flammable gas that is needed to form a flame (only burns in combination with combustion air). In the FIDAMAT 6, hydrogen is used as the combustion gas.

**Commissioning**

All measures and actions required to make a machine or system capable of running.

**Containment system**

Gas path within the gas analyzer.

**Countering**

The secured thread setting by counter-turning a second nut.

**Cross-interference correction**

Computed correction of the measured value falsification caused by the interfering gas.

**Cross-interference deflection**

The falsification of a measurement caused by an interfering gas.

**Cursor**

Tool (insertion mark, writing mark, input mark) for identifying the current editing position of a program.

**Decoded display mode**

Operating mode in which the measured value is displayed, the device is partially or completely decoded and the function control is active.

**Dialog language**

Language in which communication between the user and device takes place.

**Display**

Visible information on states and values.



Device component that outputs/shows device information and visualizes the communication via the control panel.

**Display**

Visible information on states and values.

Device component that outputs/shows device information and visualizes the communication via the control panel.

**Factory functions**

Function for device maintenance. This function is protected by the highest code level and is only accessible to maintenance personnel.

**Factory setting**

Standard settings of the device at the time of delivery.

**Flame ionization detector (FID)**

Detector for organic compounds (hydrocarbons).

**Front panel**

Front part of a device, usually with clear identification features (e.g. device name, manufacturer logo, etc.).

**Function**

Numbered software function of a device. Functions are listed in submenus.

**Function control**

Identifier that the device activates when it detects that the measured value is being influenced (e.g. at a change to operator control mode by decoding the device).

**Function display**

Content shown on the display depending on the called function.

**Gas analyzer**

Device for quantitative analysis of components of gases and gas mixtures.

**Gas inlet**

Defined point for feeding a gas to the analyzer.

**Gas outlet**

Defined point for discharging a gas from the gas analyzer.

**Housing rear panel**

Rear housing panel of the device.

**Input field**

Single or multi-line area for entering data.

**Interfering gas**

A gas that interferes with the measurement that may be contained in the sample gas.

**Leak-tightness**

Ability of containment system to prevent escape of gases.

**Limit alarm**

Signaling of high or low violation of a limit.

**Limit alarm on/off**

Function that monitors for compliance with adjustable limits, and signals a high/low violation.

**Limit relay**

Relay to which a certain limit is assigned and that is switched when there is a limit alarm.

**Main menu**

Menu of the highest hierarchical level. It contains the submenus.

**Measured signal**

Representation of measured variables in the path of the signal flow by assigned physical quantities of the same or different type. Depending on the position of the measured signal at the input or output of the relevant measuring component, one distinguishes between an input signal and an output signal.

**Measured value**

A value that is output and represents a determined measured variable.

**Measured value display**

Totality of the displayed information in "Coded display mode" and "Decoded display mode". The following are displayed, for example: measured value, status line with status messages, bottom line, measuring ranges, component, etc.

**Measuring point**

Location where a measured value is recorded.

**Measuring point relay**

Relay to which a measuring point is assigned.

**Measuring range**

The measuring range has a reference number, e.g. 1. It is characterized by a start-of-scale value and a full-scale value.

**Membrane keyboard**

Keyboard whose keys are protected against atmospheric influences by a membrane.

**Motherboard**

Board that contains the basic data and firmware for the device.

**Noise**

Totality of all phenomena that have a disturbing effect on the transfer and/or receipt of information.

**Operating mode**

Various modes into which the device can be put as a result of external actions. Three modes are distinguished:

- Coded display mode
- Decoded display mode
- Operator control mode

**Operating state**

Generic term for a number of independent states that the device can assume during operation (e.g. measuring, standby, pause, etc.).

**Operation level**

Certain operating area (menus and functions) that is either freely accessible or protected by a code.

**Operator control mode**

Operating mode in which the device is partially or entirely decoded and the function control is activated. The device parameters are assigned in this mode.

**Operator panel**

Panel with operator input elements that enable inputs to be made on the device.

**Polarization voltage**

Voltage that is applied to two opposite electrodes to form an electric field.

**Sample gas**

A gas which has been from taken from a process for analysis.

**Signaling contact**

Contact (usually floating) contained in electronic components (e.g. relay) that 'signals' the occurrence of an event defined as a fault to a control unit.

**Span**

Difference between defined start-of-scale value and full-scale value of the measuring range

**Span calibration**

Calibration of the span using a suitable calibration gas.

**Spike**

Undesired, temporary square-edged interference of a measured signal.

**Start-up state**

Settable operating state that the device changes to after successful completion of the warm-up phase.

**Status message**

Configurable output of various messages in the status line of the measured value display.

**Subfunction**

Independent functional unit within a function.

**Submenu**

Menu that is listed under a higher-order menu item.

**Supply gas**

Generic term for combustion gas and combustion air.

**Time constant**

System parameter that determines how a system-relevant variable changes with time.

**Warm restart**

Restart of device from its "warm" state with the last set parameters.

**Warm-up phase**

Time that the analyzer needs to reach operating temperature after being switched on. It counts as one of the operating states.

**Weighting**

Evaluation of single factors of a solution approach with regard to their importance. It has the effect that more relevant factors have a greater influence on the result.

**Zero calibration**

Calibration of the zero point with a suitable zero gas.

**Zero gas**

Gas used to calibrate the zero point.

**Zero point**

Smallest possible point of a measuring range (usually the start-of-scale of the measuring range).



# Index

## C

- Communication interface
  - ELAN, 30
  - PROFIBUS-DP/PA, 34
  - SIPROM GA, 32
- Connecting
  - Gas, 45
  - Power supply, 48
- Connecting signal cables, 47
- Connecting the power supply, 48
- Connection
  - Signal cables, 47
- Connections
  - FIDAMAT 6-E, 43
- Connections
  - FIDAMAT 6-G, 44

## D

- Date of manufacture, 12
- Delivery, 11
- Design
  - Device,
- Design
  - Enclosure, 22
- Device modifications, 16
- Dimensional drawings, 173
- Drift values, 89

## E

- ELAN
  - Interface, 30
  - Operating principle, 30
- ESD guidelines, 176

## F

- Faults, 141

## G

- Gas flow
  - FIDAMAT 6-E, 28, 182
  - FIDAMAT 6-G, 29, 183
- Gas flow diagram with spare parts
  - FIDAMAT 6-E, 149
  - FIDAMAT 6-G, 152
- Guidelines
  - ESD guidelines, 176

## I

- Installing
  - Requirements, 38
- Intended use, (See Device modifications)
- Interface
  - PROFIBUS, 127
  - RS485, 30

## M

- Maintaining the device, 135
- Maintenance requests, 139
- Measured value display and operator panel, 65
- Method of operation, 26
- Mounting location
  - Requirements, 38

## O

- Operating modes, 67
- Operating principle
  - ELAN interface, 30
  - PROFIBUS, 34
- Operating states
  - FIDAMAT 6-E, 60
  - FIDAMAT 6-G, 61
- Operator control functions, 75, 178
  - PROFIBUS, 127
- Operator functions
  - Drift values, 89

## P

- Parameters
  - PROFIBUS, 127
- Pin assignment of the option board and PROFIBUS connector, 50, 181
- Power connection, 48
- PROFIBUS, 127
- PROFIBUS-DP/PA, 34
- Proper use, 10

## Q

- Qualified personnel, 11

## R

- Replacing
  - Line fuses, 137
  - Motherboard, 136
  - Option/adaptor boards, 136
  - Thermal fuse, 137
- Replacing line fuses, 137
- Replacing the motherboard, 136
- Replacing the option board/motherboard, 136
- Replacing the thermal fuse, 137
- Return procedure, 176
- RS485, 30

## S

- Sample gas disposal, 45
- Serial number, 12, 12
- Service, 175
- Setting
  - PROFIBUS parameters, 127
- SIPROM GA, 32
  - Upgrade, 33
- Spare parts list, 146
- Support, 175
- Symbols, (Refer to warning symbols)

## T

- Technical specifications
  - FIDAMAT 6, 167
  - FIDAMAT 6-E, 169
  - FIDAMAT 6-G, 170
- Technical Support, 175

## W

- Warm-up phase, 58
- Warning symbols, 15
- Warranty, 11, 11

## Y

- Year of manufacture, 12





## Get more information

[www.siemens.com/processanalytics](http://www.siemens.com/processanalytics)

Siemens AG  
Digital Industries  
Process Automation  
Analytical Products  
76181 Karlsruhe

GERMANY

Subject to changes without prior notice  
A5E00222135  
© Siemens AG 2019

A5E00222135-04

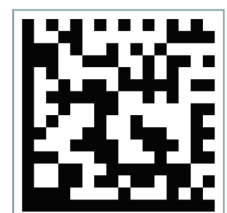
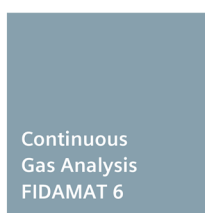

[www.siemens.com/automation](http://www.siemens.com/automation)