



ATTACHMENTS

Make it EZ!

1-877-433-5733

www.ezspotur.com



Make it EZ!

ATTACHMENTS



**DOUBLE POLE
CLAW
EZ-0008**



Make it EZ!



**SAFETY
FEATURES**



**DOUBLE POLE CLAW (EZ-0008)
w/ Double Cylinder Rotating Base (EZ-001D)**

ROTATION SAFETY

The rotation cycle has a mechanical stop to prevent the hydraulic cylinders from exceeding their maximum extension.

**DOUBLE POLE CLAW (EZ-0008)
w/ Fixed Base (EZ-001F)**

Decal Safety

All units have pictorial and written decals



Make it EZ!

HOSE SAFETY

SPRING HOSE MOUNT

- All hydraulic hoses are Cordura protected.

- Hoses have an operating pressure of 3,000psi

- Hoses have a burst pressure of 12,000psi.

- The spring hose unit insures that the hydraulic line will not get pinched.

- The spring hose unit keeps the hoses out of the dirt



EZ SPOT UR
ATTACHMENTS

Make it EZ!

CONNECTION SAFETY

Quick attach plate has doublers at the pin holes to insure they will not tear out.

Quick attach plate has gusset on top for extra support

QUICK ATTACH GUSSET

DOUBLERS

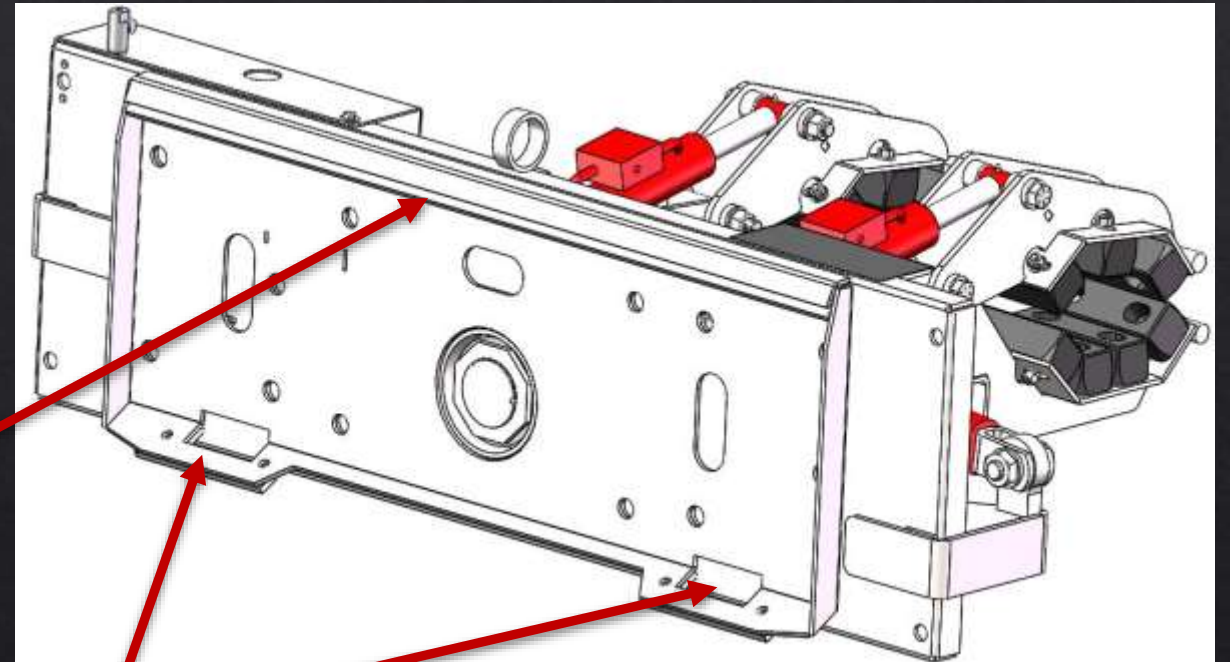

Clamp Specifications

1. ROTATION CYLINDERS

- 2.5"x12.5" CLAMP CYLINDERS
- Break out force of 14,726 lbs

2. CLAMP CYLINDERS

- 2"x6" CLAMP CYLINDERS
- Break out force of 9,425 lbs
- Grips pole securely
- The upper clamp arms operate in sequence which ensure that a pole is not unintentionally dropped.

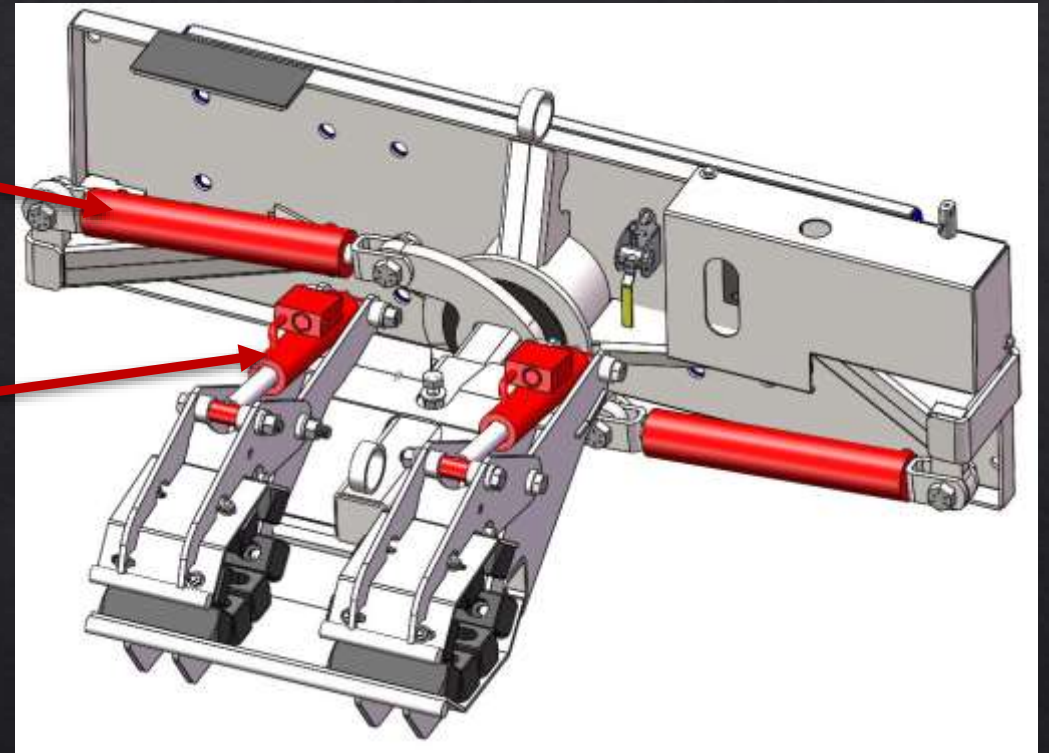

Clamp Safety

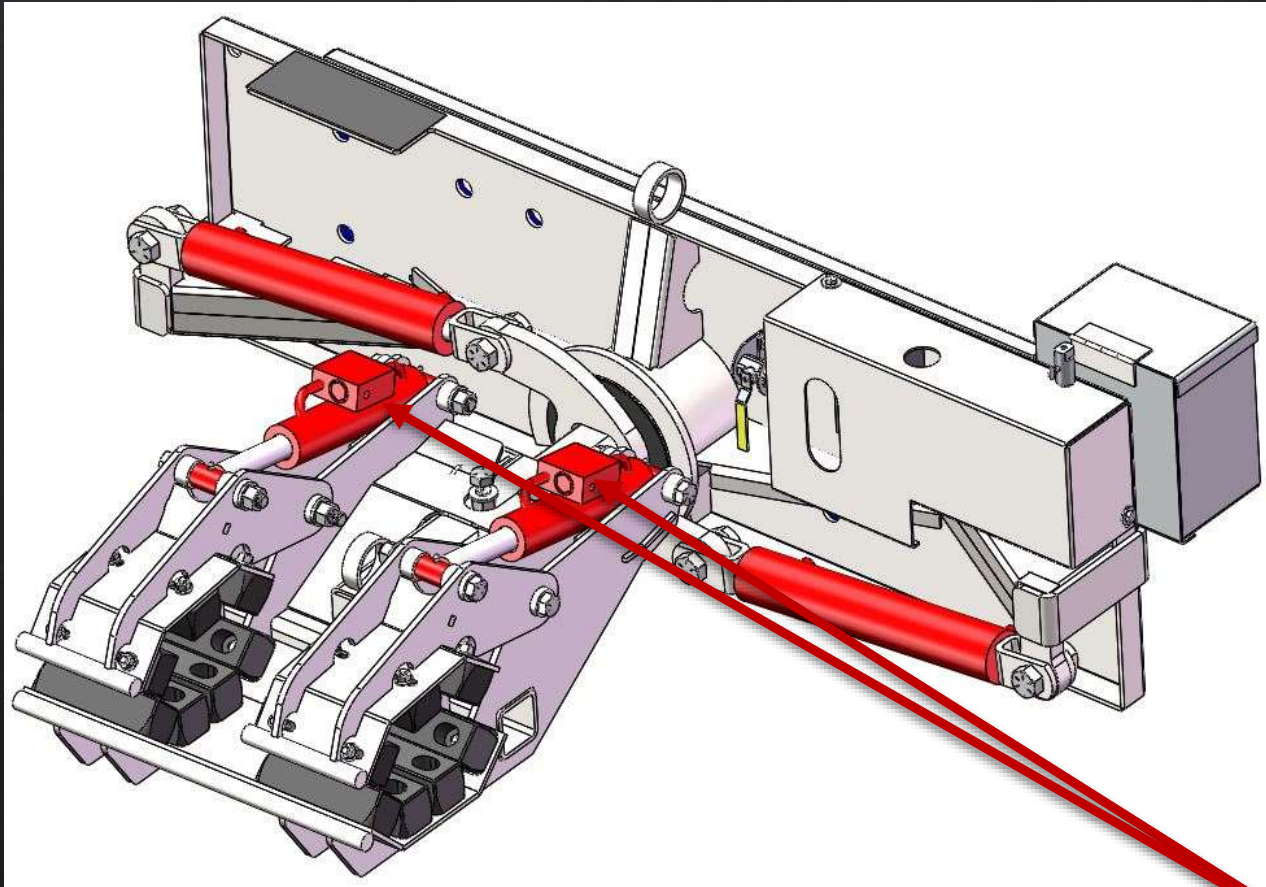

Clamp Safety

The clamp cylinders are protected by check valves which maintains clamp if hydraulic pressure is lost.

Check Valves

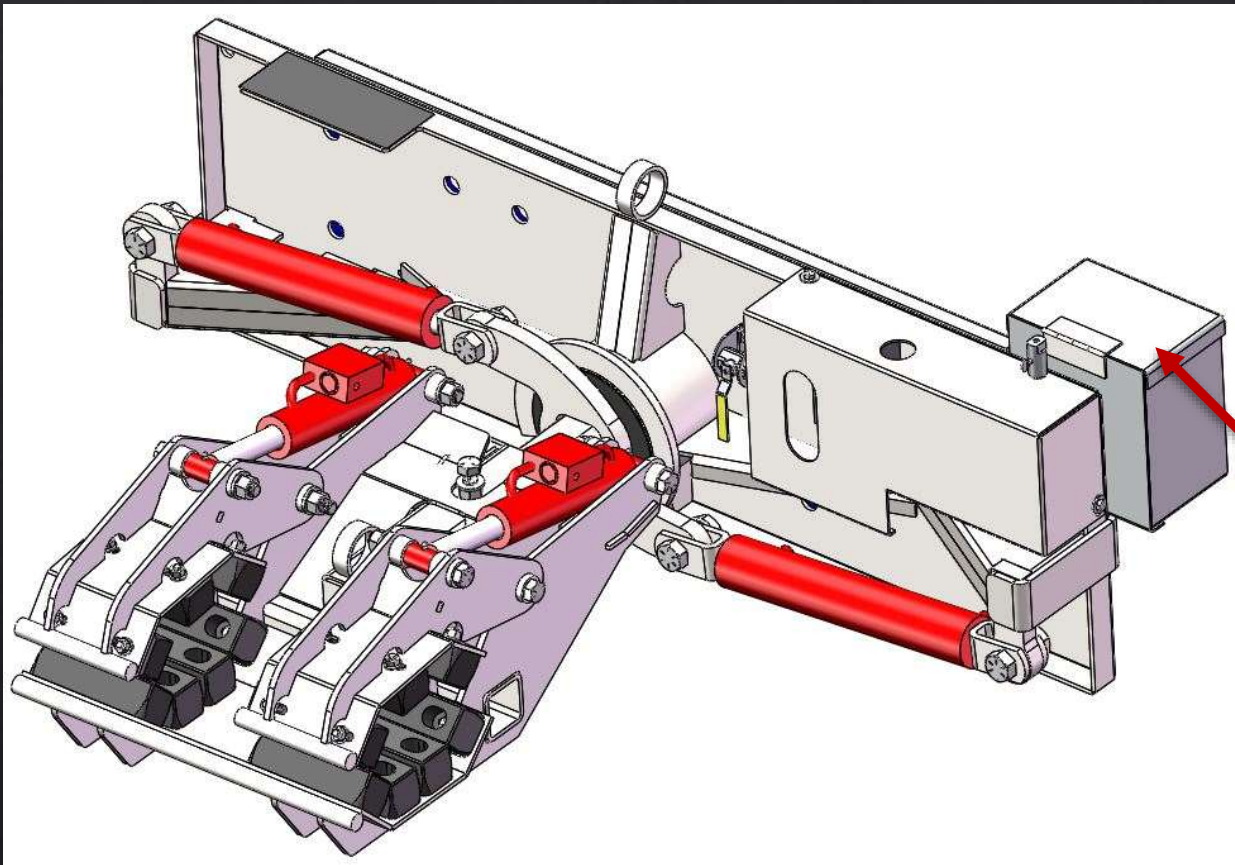

Optional Battery Box for machines without electrical connections

SHAFT SAFETY

The main rotating shaft is made of solid 3 ½ inch 4140 OQT
Front of shaft is milled down to 3 inch square and slides into the
receiver of the toolhead.

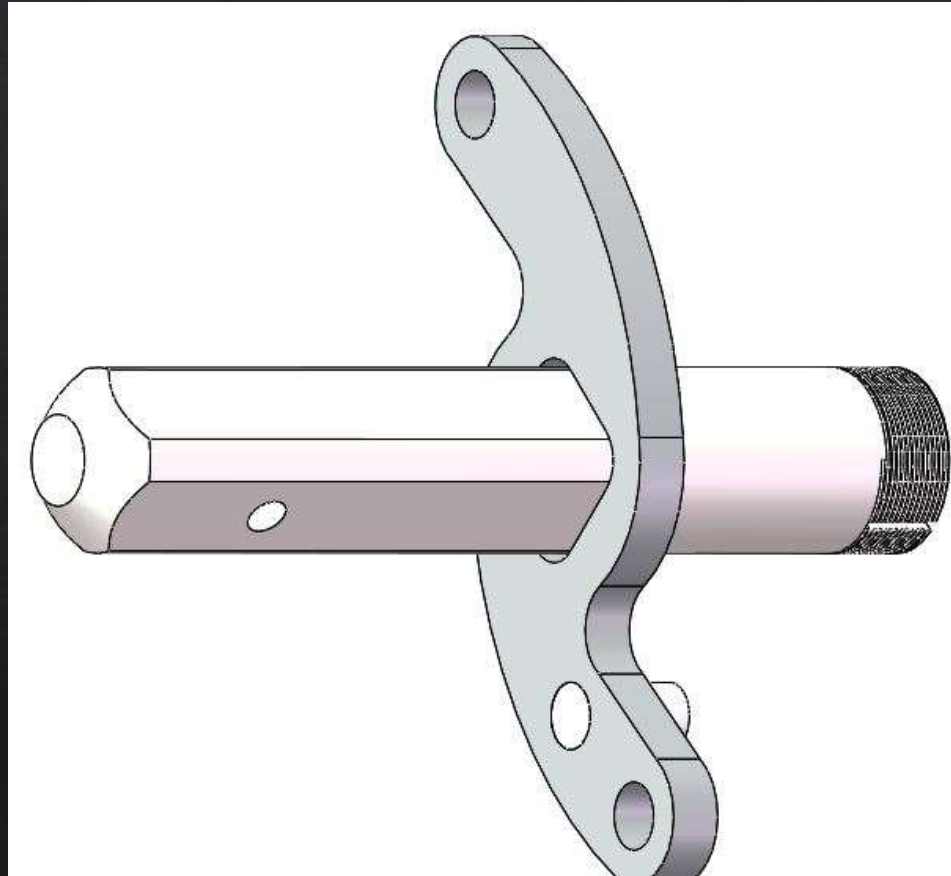

Ideal for:

POLE BUILDINGS

FLAG POLES



EZ SPOT UR
ATTACHMENTS *Make it EZ!*

LIGHT POLES



SOLAR PROJECTS

EZ SPOT UR
ATTACHMENTS

Make it EZ!

FENCING



POSTS



EZ SPOT UR
ATTACHMENTS *Make it EZ!*

HANDLES:

METAL POLES



WOOD POLES



TWO BY FOUR'S



PIPES



ATTACHES TO ANY MACHINE



SKID STEERS



MINI EXCAVATORS



EXCAVATORS



Product Specifications

- Universal Quick Tach' mounting system.
- Can be adapted to fit any machine
- Rotates -5° to 110° to the operators left when attached to an EZ Spot UR Double Cylinder Rotating Base.
- Can also be attached to an EZ Spot UR Fixed Non-Rotating Base.
- Can be used on the mini excavator rotating base and rotates -90° to 110°
- Jaws will open to 12.8 inches
- Closes down to 3.56 inches.
- Inserts can be purchased which allow the attachment to close down to 0.
- The jaws are rubber lined to prevent damage to the pole.



EZ SPOT UR
ATTACHMENTS

Make it EZ!

Product Specifications

- Weight of attachment with Double Cylinder Rotating Base is 730 lbs
- Rated for 32 foot poles
- Rated weight capacity is 1,100 lbs
- Comes complete with 3/4" flush faced couplers
- Includes spring hose mount
- Includes wiring harness.
- Grade 8 bolts
- Composed of Grade 80 material or higher
- Core Welded



EZ SPOT UR
ATTACHMENTS *Make it EZ!*

DOUBLE POLE CLAW VIDEO





Make it EZ!

**ALL EZ SPOT UR PRODUCTS
ARE PROUDLY MADE IN THE
USA
AND COME WITH A
ONE YEAR WARRANTY**

