

Project Name: _____
Date: _____ **Note:** _____

LED BACK-LIT PANEL LIGHT - Watt and CCT Selectable

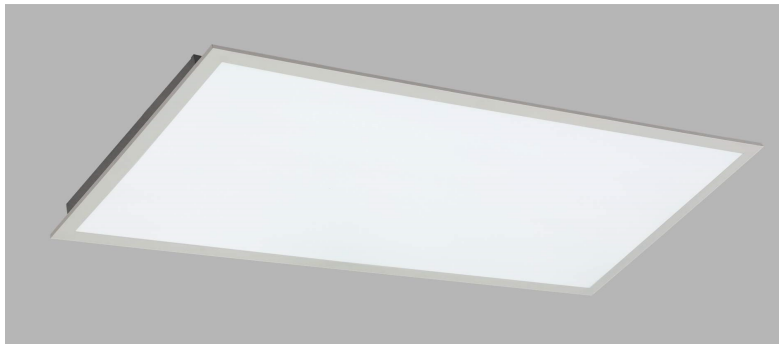

Application: Office, school, conference room, hospital, and more commercial spaces

Product Description

LED Back-Lit Panel is a direct lighting product with high lumen efficiency. It makes full use of all light and is more cost effective compared with edge lighting LED panel light. Adopt optical lens to offer a uniform light effect. With integrated iron plate, providing great thermal management.

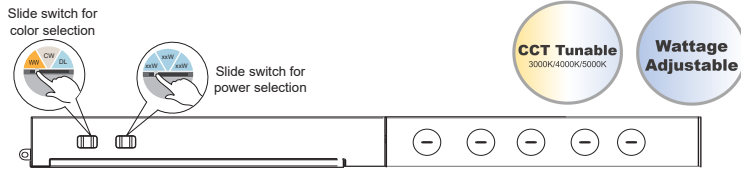

Certifications



SPECIFICATIONS

Model No.	HY-PB-1X4P-3W3CCT	HY-PB-2X2P-3W3CCT	HY-PB-2X4P-3W3CCT	HY-PB-2X4PH-3W3CCT
Wattage	20W/30W/40W		30W/40W/50W	40W/50W/60W
Size	1'x4'	2'x2'	2'x4'	
Lumens	2600/3900/5200 LM		3900/5200/6500 LM	5200/6500/7800 LM
Rated Input Voltage(V)	AC100-277V			
Dimming	0-10V Dimmable			
CCT	3K/4K/5K Selectable	3K/4K/5K or 4K/5K/6K Selectable	3K/4K/5K Selectable	4K/5K/6K Selectable
CRI	≥80			
Beam Angle (°)	120°			
Electrical Class	Class I			
Lumen Efficiency	130 Lm/W			
Color Rendering Index	Ra>70			
Lens	Translucent White			
Working Temperature	-4 ° F ~ +122 ° F / -20°C ~ 40°C			
Storage Temperature	-4 ° F ~ +149 ° F / -20 ° C ~ +65 ° C			
Environment Location	IP 20 – Indoor Only			
Lifespan	> 50000H			
Lampshell	White			
DLC ID	P2U165MP	PYKN0DJH	PLW4UJM5	PGFO00AG
Package Info	49.6" x 13.6" x 4.33"	25.19" x 25.59" x 4.33"	49.61" x 25.59" x 4.33"	
PC/ Master Pack	2	2	2	
Weight	14LB	12 LB	23 LB	

FEATURE

- Uniform light effect with optic lens
- Integrated iron plate design provides excellent thermal management.
- Direct light design provides more even light distribution and longer lifespan

OPTIONAL ACCESSORIES

Type	Image	Size
Surface Mount Kit		Available in all 3 sizes
Emergency Back Up		Available in 8W and 15W

ORDERING CODE DEFINITION

EXAMPLE: HY-PB-2X2P-3W3CCT

Company Code	Product	Size	P	Power: 3W	CCT: 3CCT
HY	PB: LED Backlit Panel	2'x2'	P: DLC Premium Listed	2'x2' : 20W/30W/40W 1'x4' : 30W/40W/50W or 40W/50W/60W	CCT Selectable: 4K/5K/65K or 3K/4K/5K
		1'x4'			
		2'x4'			

PRODUCT DIMENSION

2X2

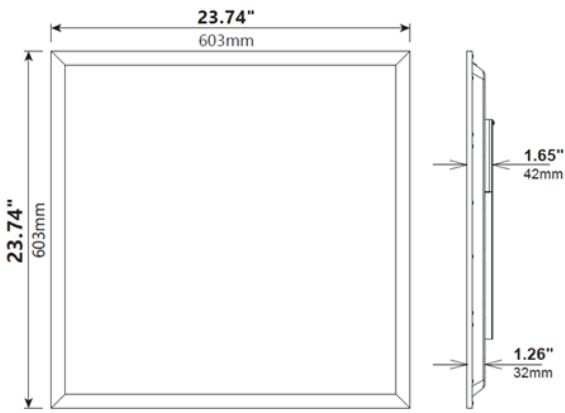

2X4

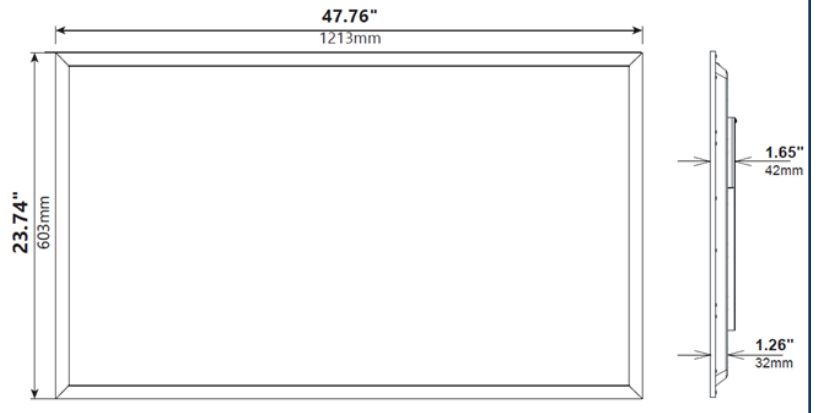

1x4

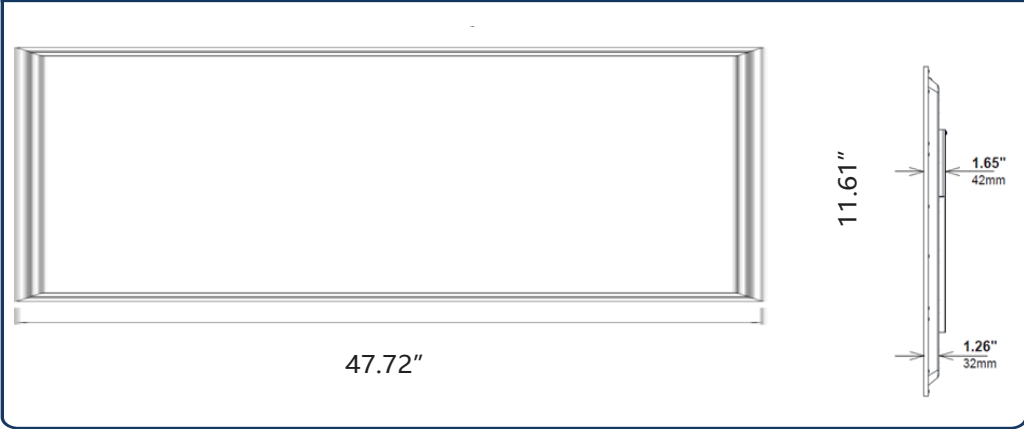

WIRING GUIDE

1. Remove the knock down hole on box by screwdriver

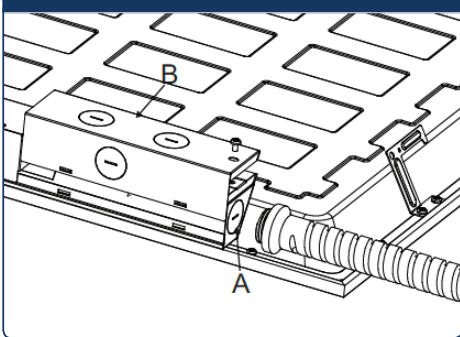

2. Connect the wire as the picture showing

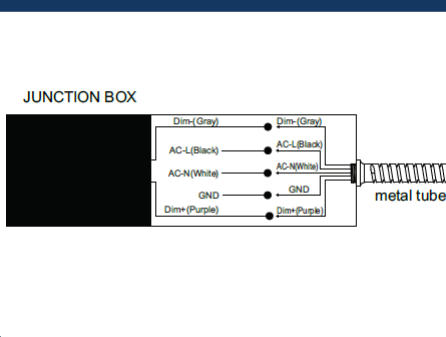

3. Cover the driver box and tighten it

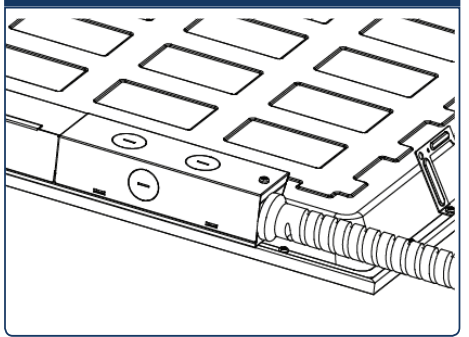

Watt and CCT Selectable

1'x4' and 2'x2'

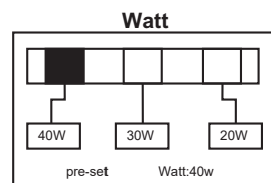

2'x4'

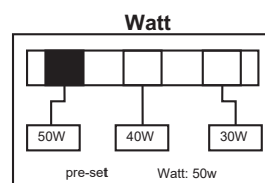

PRODUCT INSTALLATION

RECESSED

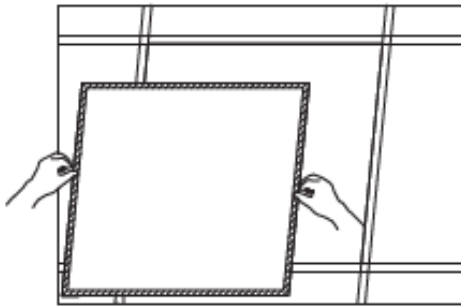

←
① Remove the ceiling plaster slab.

② Feed the main AC wire in driver terminal block respectively, connect the panel light and driver.

←
③ Fix the panel light into plaster ceiling.

④ Make sure the led panel light is firmly fixed, turn on the power.

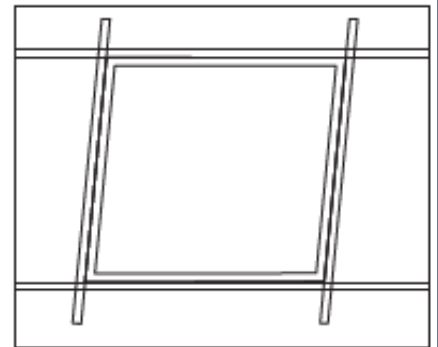
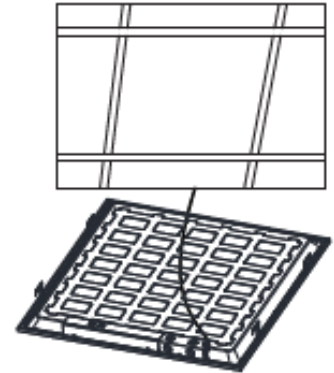

SURFACE MOUNTED

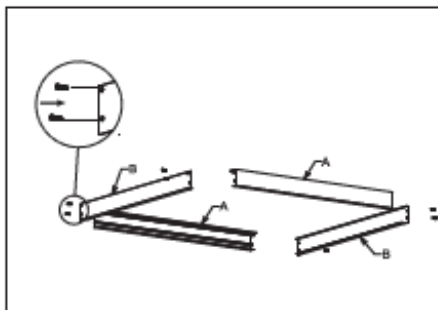

←
① Assemble the surface mounted frame and fix by screws.

② knock the plastic anchor into ceiling, fix the surface mounted frame on the ceiling by screws.

④ Fix the side frame back by screw.

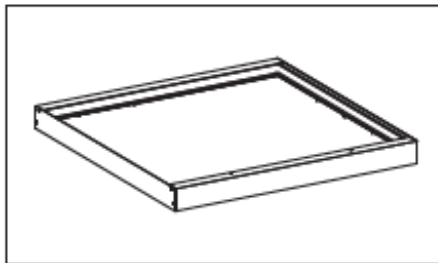

⑤ Make sure the frame and panel light are firmly fixed, turn on the power.

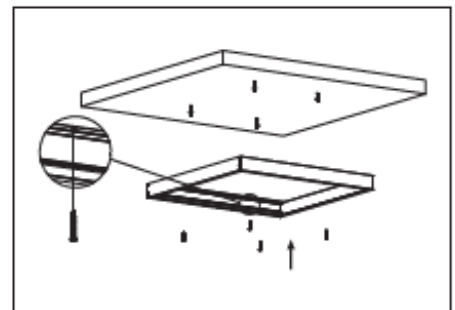
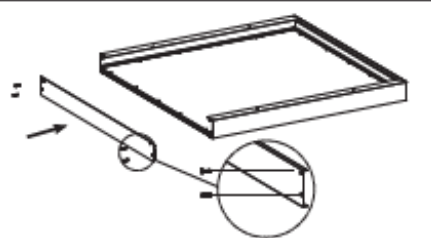

③ Unscrew the side frame then take out, connect the panel light to power supply, insert the panel light into the frame.

