



Haven Industries

U-Trough Power Sweep Installation & Operator's Manual

This manual applies to:

U-Trough:	Bin Diameters: 19', 21', 24', 27', 30', 33',
Powersweep	36', 29', 42', 45', 48', 54', 60', 72', 78'
Unload	

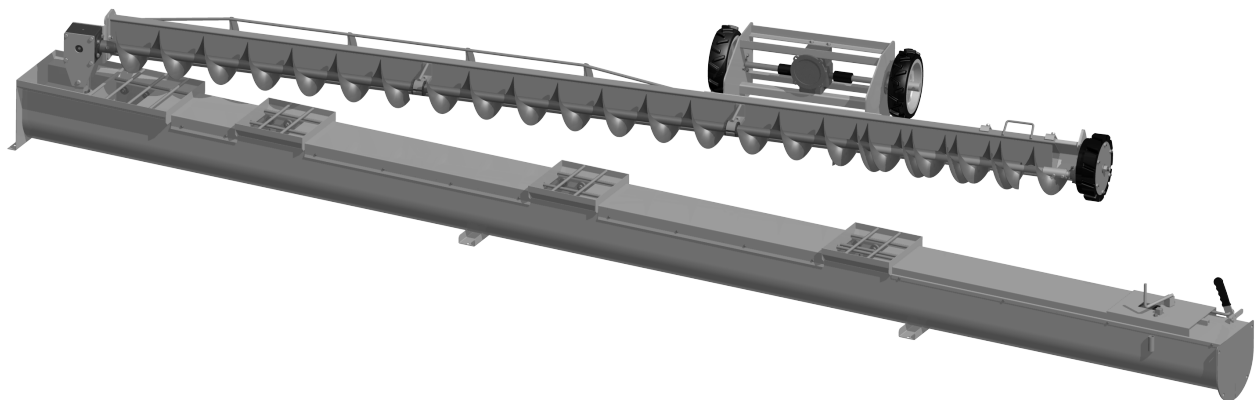

CONTENTS

1. Introduction.....	4
1.1. Intended Use.....	4
1.1.1 Misuse	4
2. Safety.....	5
2.1. Safety Alert Symbol and Signal Words.....	5
2.2. General Product Safety.....	6
2.3. Rotating Flighting Safety	6
2.4. Rotating Parts Safety	6
2.5. Work Area Safety	6
2.6. Guards Safety	6
2.7. Bin Unloading Safety.....	6
2.8. Bin Entry Safety	7
2.8.1 Roof Entry	7
2.9. Bin Emergency Entry	7
2.10. Bin Entrapment	8
2.10.1 Flowing Grain.....	8
2.10.2 Collapse of Bridged Grain.....	9
2.10.3 Collapse of a Vertical Wall of Grain	9
2.12. Drives and Lockout Safety	11
2.12.1 Electric Motor Safety.....	11
2.12.1 Hydraulic Motor Safety	12
2.13. Personal Protective Equipment.....	12
2.14. Safety Equipment.....	13
2.15. Safety Decals.....	14
2.15.1 Decal Installation/Replacement	14
2.15.2 Safety Decal Locations and Details	14
3. Installation.....	18
4. Operation.....	20
4.1. Operation Safety	20
4.2. Bin Unload Overview	20
4.3. Before Filling the Bin with Grain.....	21
4.4. Operation of the Powersweep system	21
4.5. Emergency Shutdown.....	22
4.6. Restarting with Full Underfloor Auger	23
4.7. Cleanup.....	23
4.8. Extended Shutdown / End of Season	23

- 5. Maintenance..... 24**
 - 5.1. Maintenance Safety 24
 - 5.2. Maintenance Schedule..... 24
 - 5.3. Visually Inspect the Equipment 25
 - 5.4. Inspect Hydraulic Hoses and Fittings..... 25
 - 5.5. Clean and Wash the Equipment..... 25
 - 5.6. Check the Gearbox Oil 26
 - 5.7. Change the Gearbox Oil 26
 - 5.8. Tension the Belt Drive 26
 - 5.9. Align the Drive Belts 27
 - 5.10. Replace the Drive Belts..... 27
 - 5.11. Replace the Sweep Drive Wheel..... 27
 - 5.12. Adjust the Bin Sweep Backboard 28
 - 5.13. Removing the Underfloor Auger Flighting 29

- 6. Troubleshooting 30**

- 7. Specifications 34**
 - 7.1. Mechanical..... 34
 - 7.2. Power Requirements 35

1. Introduction

Thank you for purchasing a Grain Saver U-Trough Powersweep System. This equipment will allow safe and efficient operation when you read and follow all of the instructions contained in this manual. With proper care, your powersweep will provide you with many years of trouble-free operation.

Keep this manual handy for frequent reference and to review with new personnel. If any information in this manual is not understood or if you need additional information, please contact your local distributor or dealer for assistance.

This manual should be regarded as part of the equipment. Suppliers of both new and second-hand equipment are advised to retain documentary evidence that this manual was provided with the equipment

1.1. Intended Use

The Powersweep is designed solely for use in the intended agricultural use as listed below. Use in any other way is considered as contrary to the intended use. Compliance with and strict adherence to the conditions of operation and maintenance as specified by the manufacturer, also constitute essential elements of the intended use.

The bin unload should be operated, maintained, serviced, and repaired only by persons who are familiar with its particular characteristics and who are acquainted with the relevant safety procedures.

Accident prevention regulations and all other generally recognized regulations on occupational health and safety must be observed at all times.

Any modifications made to the bin unload may relieve the manufacturer of liability for any resulting damage or injury.

Intended use for the powersweep:

- Handling grain, pulse crops, treated seeds, or other similar materials.

Use in any other way is considered as contrary to the intended use and is not covered by the warranty.

1.1.1 Misuse

Do not install/use the bin unload for/with:

- transferring material other than dry, free-flowing food-grains.
- commercial or off-farm use.

2. Safety

2.1. Safety Alert Symbol and Signal Words



This safety alert symbol indicates important safety messages in this manual. When you see this symbol, be alert to the possibility of injury or death, carefully read the message that follows, and inform others.

Signal Words: Note the use of the signal words **DANGER**, **WARNING**, and **CAUTION** with the safety messages. The appropriate signal word for each message has been selected using the definitions below as a guideline.



Indicates an imminently hazardous situation that, if not avoided, will result in serious injury or death.



Indicates a hazardous situation that, if not avoided, could result in serious injury or death.



Indicates a hazardous situation that, if not avoided, may result in minor or moderate injury.



Indicates a potentially hazardous situation that, if not avoided, may result in property damage.

2.2. General Product Safety

YOU are responsible for the **SAFE** use and maintenance of your powersweep. **YOU** must ensure that you and anyone else who is going to work around the powersweep understands all procedures and related **SAFETY** information contained in this manual.

Remember, **YOU** are the key to safety. Good safety practices not only protect you, but also the people around you. Make these practices a working part of your safety program. All accidents can be avoided.

- It is the powersweep owner, operator, and maintenance personnel's responsibility to read and understand **ALL** safety instructions, safety decals, and manuals and follow them when operating, or maintaining the equipment.
- Owners must give instructions and review the information initially and annually with all personnel before allowing them to operate the powersweep. Untrained users/operators expose themselves and bystanders to possible serious injury or death.
- The powersweep is not intended to be used by children.
- Use the bin unload for its intended purposes only.
- Do not modify the bin unload in any way without written permission from the manufacturer. Unauthorized modification may impair the function and/or safety, and could affect the life of the bin unload. Any unauthorized modification will void the warranty.
- Follow a health and safety program for your worksite. Contact your local occupational health and safety organization for information.

2.3. Rotating Flighting Safety

DANGER

- KEEP AWAY from rotating flighting.
- DO NOT remove or modify flighting guards, doors, or covers. Keep in good working order. Have replaced if damaged.
- DO NOT operate the bin unload without all guards, doors, and covers in place.
- NEVER touch the flighting. Use a stick or other tool to remove an obstruction or clean out.
- Shut off and lock out power to adjust, service, or clean.



2.4. Rotating Parts Safety

WARNING

- Keep body, hair, and clothing away from rotating pulleys, belts, chains, and sprockets.
- Do not operate with any guard removed or modified. Keep guards in good working order.
- Shut off and remove key or lock out power source before inspecting or servicing machine.



2.5. Work Area Safety

- Have another trained person nearby who can shut down the bin unload in case of accident.
- The work area should be kept clear of bystanders.
- Keep the work area clean and free of debris.

2.6. Guards Safety

WARNING

- Keep guards in place and do not operate unless all guards are in place.
- Do not walk on, step on, or damage guards.
- Lock out power before removing a guard.
- Ensure all guards are replaced after performing maintenance.

2.7. Bin Unloading Safety

WARNING

- Never enter a bin when loading or unloading.
- Unload only as described in the operation section of this manual.
- Lock the bin door (where equipped) and close/lock all other access doors when not in use.

2.8. Bin Entry Safety

The information in this section applies to entry through any access point.

Always try to work and solve problems without entering a bin.



If you must enter the bin, follow the safety information below to safely enter through the roof or door:

- Stop the unloading process if the bin is being unloaded and lockout/tagout power before entering the bin, refer to Lockout/Tagout Safety.
- Always wear a dust-filtering respirator when entering the bin. Grain dust and spores when inhaled into the lungs can cause severe reactions leading to hospitalization in some cases. Persistent exposure may cause “farmer’s lung,” which can eventually be fatal.
- Before working inside the bin, ventilate the area by opening the vent or by other equivalent means to force air into the bin to prevent oxygen-deficient atmosphere. Inadequate oxygen is very harmful to your health and can cause death. Exposure to carbon dioxide can cause drowsiness, headache and even death due to suffocation. Test the atmosphere. If the carbon dioxide hazard cannot be reduced or eliminated or you cannot test the atmosphere, use correctly fitted and appropriate respirator.
- Never walk on grain to make it flow.

If you ignore the safety precautions above and enter the bin, you could die from being submerged.

2.8.1 Roof Entry

The information in this section applies to entry through the bin roof only.



- Never enter a bin from the roof if you don’t know its unloading history. Bridges of stored material can form above a void space below, causing potential for entrapment.
- Have body harness tethered to a lifeline controlled by two others outside the bin. One worker should be able to see inside worker through the inspection hatch. If there is an accident, one worker can focus on the victim while the other goes/calls for help.
- In the event that you are trapped in the bin as it is unloading, move as quickly as possible toward the bin wall; keep yourself elevated above the material by walking on the flowing mass while staying as close as possible to the bin wall.

2.9. Bin Emergency Entry

In an emergency situation:

- Follow protocols set by your local occupational safety and health agency.
- If you need to rescue somebody inside the bin, call emergency responders and only attempt to rescue using non-entry rescue procedure/equipment. Do not enter the bin unless you are trained for rescue, equipped and relieved by another attendant.

2.10. Bin Entrapment

It takes more than 1000 lb (4.5kN) of force to remove someone buried below the surface.

The following sections cover common ways a person gets submerged or trapped:

2.10.1 Flowing Grain

WARNING

- Grain flows in a funnel-shaped path when unloading. This vortex of grain behaves very much like a water drain. Velocity increases as grain flows from the bin wall at the top of the grain mass into a small vertical column at the center of the bin.
- Flowing grain will not support the weight of a person. Submersion happens within seconds.

Figure 1. Suffocation Hazards in Flowing Grain

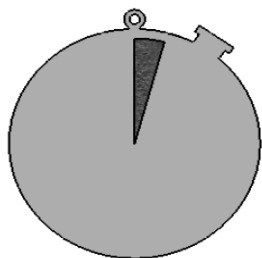
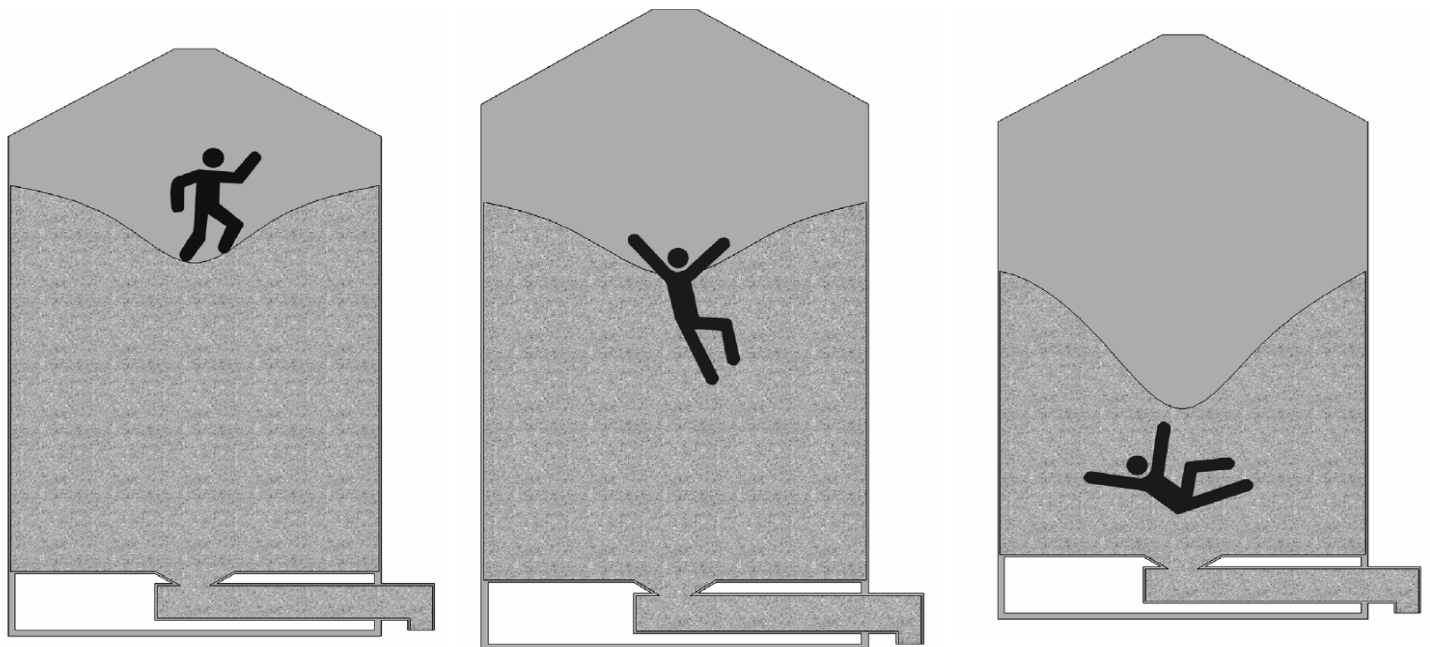

2-3 SECONDS

AFTER THE UNLOADING EQUIPMENT STARTS, YOU HAVE 2-3 SECONDS TO REACT

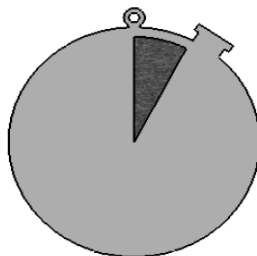

4-5 SECONDS

IN 4-5 SECONDS, YOU ARE TRAPPED

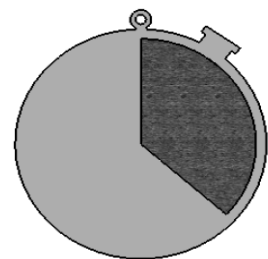

22 SECONDS

AFTER 22 SECONDS, YOU ARE COMPLETELY COVERED.

2.10.2 Collapse of Bridged Grain

WARNING

- Grain can “bridge” across a bin, creating an empty air space below. A person can easily break through this bridge and become trapped, risking suffocation.
- To identify bridged grain, look for a funnel shape on the surface of the grain after having removed some of the grain. If surface is undisturbed, the grain has bridged and formed a crust.
- Never walk on the grain crust. The crust rarely becomes strong enough to support the weight of a person.
- To remove bridge, try breaking the bridge from the inspection hatch or peak. Use a pole to hit the surface, securing it with a rope in case it is dropped. Be aware that chunks of crusted grain can move down to the auger and limit flow.

Figure 2. Suffocation Hazards in Bridged Grain

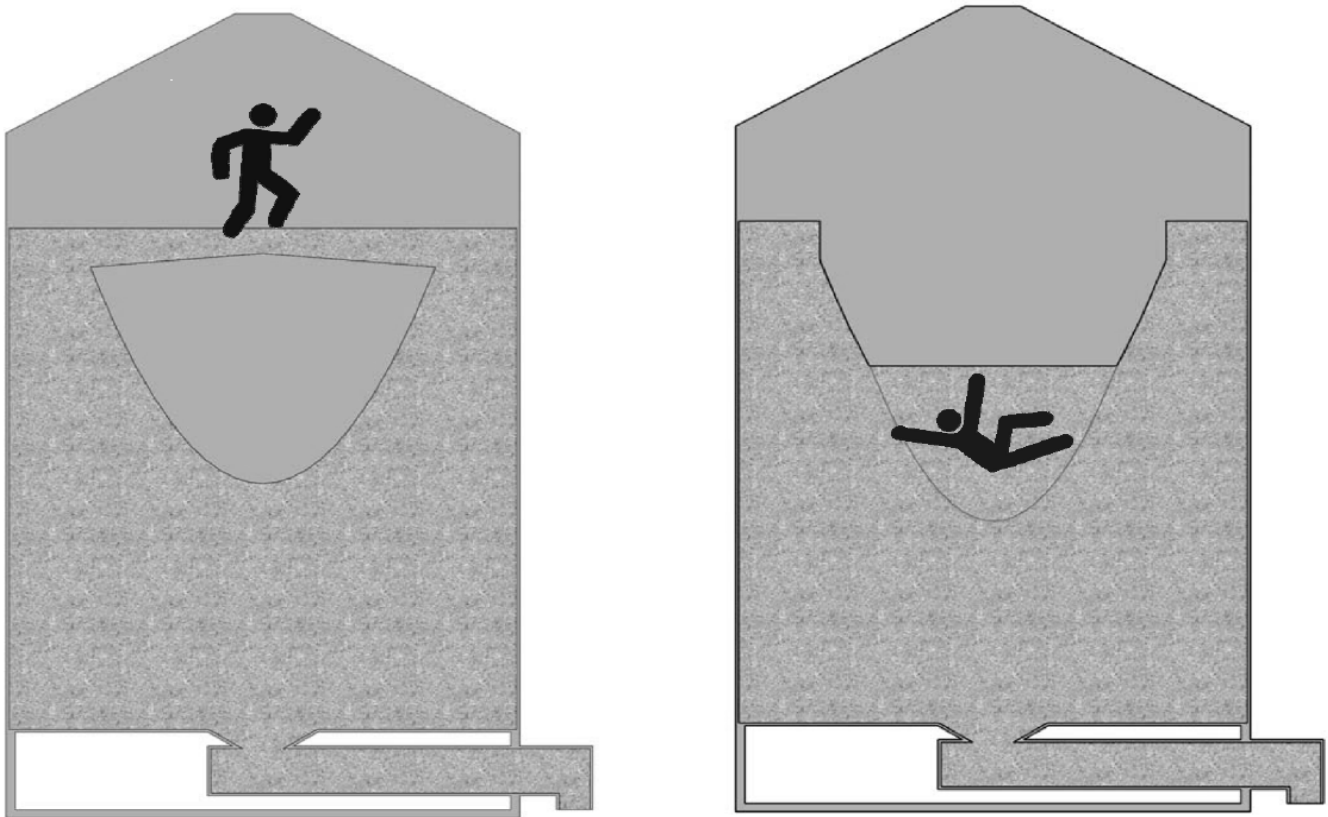

2.10.3 Collapse of a Vertical Wall of Grain

WARNING

- Vertical walls of grain are created when the bin is partially empty. Poking at the wall can make the grain avalanche and submerge a person.
- Do not enter the bin to break down grain that has set up. Break grain mass from top of the bin outside.

Figure 3. Suffocation Hazards from a Vertical Grain Wall

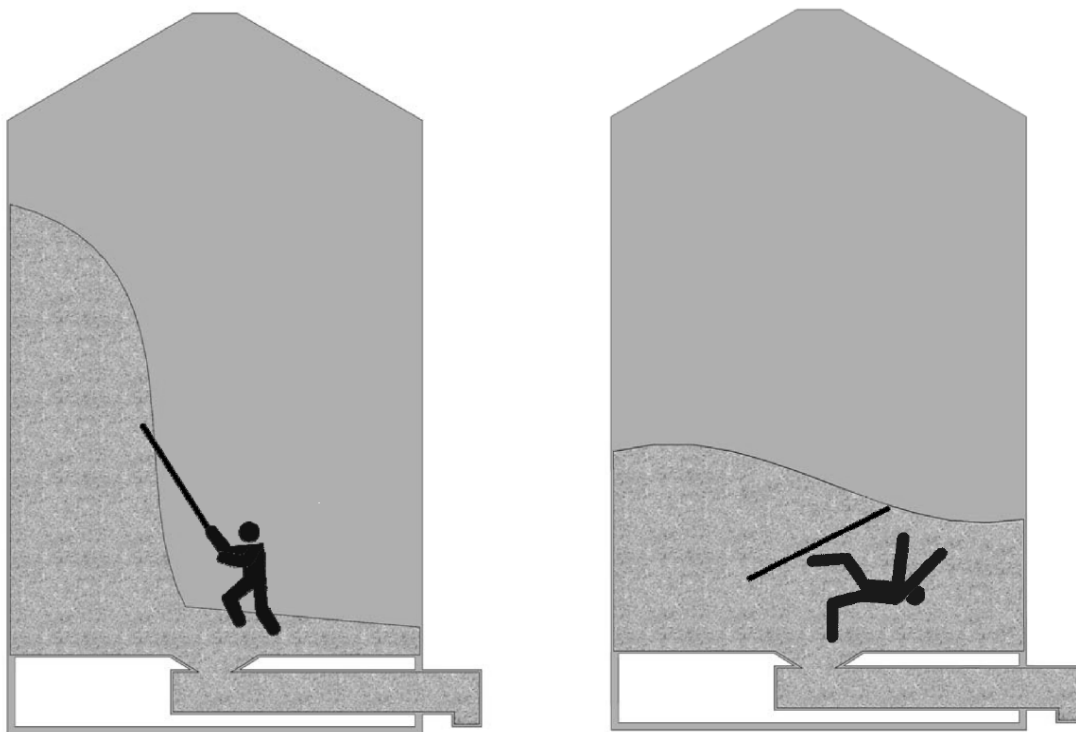

2.11. Combustible Dust



The powersweep has been designed for safe use in areas where hazards due to combustible dust may potentially occur. Minimize the risk of a dust explosion by following the preventive measures below.

Control the dust:

To control dust, consider as part of your work-site safety program to:

- Clean the grain to reduce the fines.
- Use equipment to minimize the breakage. For example, corn that is broken exposes the starch, the most explosive element of the grain.
- Use a filtering system to capture the dust.
- Use an air system to reduce the dust.
- Spray edible mineral oil on the grain to reduce air-born dust when handling.
- Paint equipment that is in the interior of a facility with a coating that is slick, not allowing the dust to accumulate.
- Clean up dust deposits after operation of the equipment.
- Enclose all equipment to keep the dust from escaping.

Control the ignition source:

To prevent possible sources of ignition that could cause fires or dust explosions:

- Do not smoke in any potentially hazardous area.
- Use only explosion-proof lights.

- Do not use anything around or inside the equipment that may produce a flame, such as a match, a lighter, or anything that may produce a shower of sparks, such as a grinder or power saw, unless the air is free of dust and all dust deposits have been removed from the work area, or the work area is wet such that dust cannot be dispersed in the air and smoldering processes from sparks cannot develop. Use brush-less electrical tools and explosion proof flash lights, for example.
- Follow the maintenance schedule to keep equipment operating at normal conditions. This will further help to prevent the risk of components overheating or wearing out which may lead to explosion risks.
- Always purchase replacement parts from the manufacturer or authorized dealer/distributor. Original manufacturers parts are designed with explosion proof features where applicable

2.12. Drives and Lockout Safety

Inspect the power source(s) before using and know how to shut down in an emergency. Whenever you service or adjust your equipment, make sure you shut down the power source and follow lockout and tagout procedures to prevent inadvertent start-up and hazardous energy release. Know the procedure(s) that applies to your equipment from the following power source(s). Ensure that only 1 key exists for each assigned lock, and that you are the only one that holds that key. Ensure that all personnel are clear before turning on power to equipment.



2.12.1 Electric Motor Safety

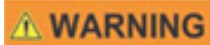

Power Source

- Electric motors and controls shall be installed and serviced by a qualified electrician and must meet all local codes and standards.
- A magnetic starter should be used to protect your motor.
- You must have a manual reset button.
- Reset and motor starting controls must be located so that the operator has full view of the entire operation.
- Locate main power disconnect switch within reach from ground level to permit ready access in case of an emergency.
- Motor must be properly grounded.
- Guards must be in place and secure.
- Ensure electrical wiring and cords remain in good condition; replace if necessary.
- Use a totally enclosed electric motor if operating in extremely dusty conditions.

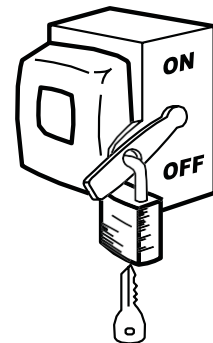

Lockout

- The main power disconnect switch should be in the locked position during shutdown or whenever maintenance is performed.
- If reset is required, disconnect all power **before** resetting motor.

2.12.1 Hydraulic Motor Safety

WARNING

Power Source

- Refer to the rules and regulations applicable to the power source operating your hydraulic drive.
- Do not connect or disconnect hydraulic lines while system is under pressure.
- Keep all hydraulic lines away from moving parts and pinch points.
- Escaping hydraulic fluid under pressure will cause serious injury if it penetrates the skin surface (serious infection or toxic reaction can develop). See a doctor immediately if injured.
- Use metal or wood as a backstop when searching for hydraulic leaks and wear proper hand and eye protection.
- Check all hydraulic components are tight and in good condition. Replace any worn, cut, abraded, flattened, or crimped hoses.
- Clean the connections before connecting to equipment.
- Do not attempt any makeshift repairs to the hydraulic fittings or hoses with tape, clamps, or adhesive. The hydraulic system operates under extremely high pressure; such repairs will fail suddenly and create a hazardous and unsafe condition.



Lockout

- Always place all hydraulic controls in neutral and relieve system pressure before disconnecting or working on hydraulic system.

2.13. Personal Protective Equipment

The following Personal Protective Equipment (PPE) should be worn when operating or maintaining the equipment.

Safety Glasses

- Wear safety glasses at all times to protect eyes from debris.



Work Gloves

- Wear work gloves to protect your hands from sharp and rough edges.



Steel-Toe Boots

- Wear steel-toe boots to protect feet from falling debris.



Coveralls

- Wear coveralls to protect skin.



Hard Hat

- Wear a hard hat to help protect your head.



Hearing Protection

- Wear ear protection to prevent hearing damage.



2.14. Safety Equipment

The following safety equipment should be kept on site:

Fire Extinguisher

- Provide a fire extinguisher for use in case of an accident. Store in a highly visible and accessible place.



First-Aid Kit

- Have a properly-stocked first-aid kit available for use should the need arise, and know how to use it.



Eyewash Kit

- Keep a portable eye wash kit available or make sure a permanent eyewash station is available should the need arise to flush materials from the eyes. Review instructions for use before working with the bin unload.



Salvage Container

- Keep a sealable salvage container on site, such as a spill containment pallet.



Absorbent Materials

- Keep granular absorbent materials on hand to clean up any chemical spills.



Aluminum Shovel and Broom

- Keep an aluminum shovel and broom for cleanup of spilled materials.

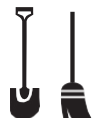

2.15. Safety Decals

- Keep safety decals clean and legible at all times.
- Replace safety decals that are missing or have become illegible.
- Replaced parts must display the same decal(s) as the original part.
- Replacement safety decals are available free of charge from your distributor, dealer, or factory as applicable.

2.15.1 Decal Installation/Replacement

1. Decal area must be clean and dry, with a temperature above 50°F (10°C).
2. Decide on the exact position before you remove the backing paper.
3. Align the decal over the specified area and carefully press the small portion with the exposed sticky backing in place.
4. Slowly peel back the remaining paper and carefully smooth the remaining portion of the decal in place.
5. Small air pockets can be pierced with a pin and smoothed out using the sign backing paper.

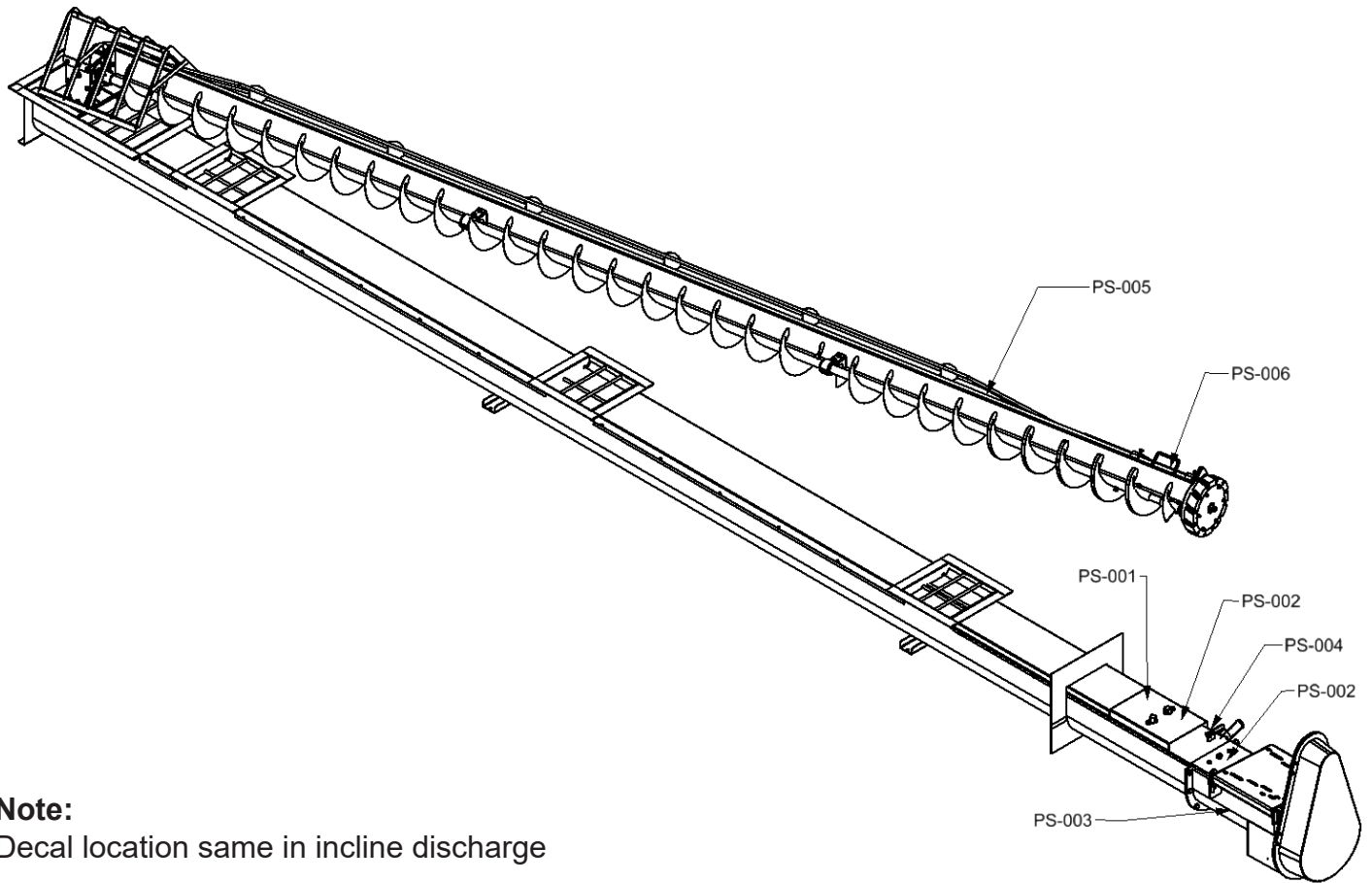

2.15.2 Safety Decal Locations and Details

Replicas of the safety decals that are attached to the bin unload and their messages are shown in the figure(s) that follow. Safe operation and use of the bin unload requires that you familiarize yourself with the various safety decals and the areas or particular functions that the decals apply to, as well as the safety precautions that must be taken to avoid serious injury, death, or damage.



Note:
Decal location same in incline discharge

Part Number	Discription
PS-002	 <p>WARNING! Never enter bin while equipment is operating. Replace all guards before starting equipment.</p>

Part Number	Discription
PS-001	<div data-bbox="673 178 1209 1060" style="border: 2px solid black; padding: 10px; background-color: #ffff00;"> <p style="text-align: center;">! CAUTION</p> <ol style="list-style-type: none"> 1. Do not operate unit without pulley shield in place. 2. Never enter bin during clean out while bin sweep is in operation. <p style="text-align: center;"><u>Operating Instructions</u></p> <p>Step 1 - Open gate #1 first - unload until grain flow stops.</p> <p>Step 2 - Open gate #2 until grain flow stops.</p> <p>Step 3 - Stop Motor - engage clutch on bin sweep and remove remaining grain.</p> <p>Step 4 - Close all slide gates and empty unload tube after use.</p> <p>Step 5 - Stop Motor - disengage clutch - return sweep to right hand position close to hoppers.</p> <p>Step 6 - Bin is ready to be refilled.</p> <div style="display: flex; justify-content: space-around; margin-top: 10px;"> <div style="text-align: center;"> <p>CENTER HOPPER GATE # 1</p>  <p>CLOSED OPEN</p> </div> <div style="text-align: center;"> <p>MIDDLE HOPPER GATE # 2</p>  <p>OPEN CLOSED</p> </div> </div> </div>
PS-006	<div data-bbox="527 1176 1372 1732" style="border: 2px solid black; border-radius: 15px; padding: 20px; background-color: #ffff00;"> <p style="text-align: center;">CHECK INSTALLATION BEFORE OPERATING!</p> <p style="text-align: center;">See the operator's manual to perform these easy procedures before initial use.</p> <ul style="list-style-type: none"> • LOCK NUT TORQUE • SPROCKET DEPTH • LUBRICATION <p style="text-align: center;">Failure to install properly will void warranty! Do not remove this decal.</p> </div>

Part Number	Discription
PS-003	<div data-bbox="485 174 1421 722" style="background-color: yellow; border: 1px solid black; padding: 10px;"> <p style="text-align: center; font-size: 2em; font-weight: bold; margin: 0;">CAUTION!</p> <p style="text-align: center; font-weight: bold; margin: 5px 0 0 0;">TO AVOID POSSIBLE SERIOUS INJURY</p> <ul style="list-style-type: none"> • KEEP HANDS, FEET AND LOOSE CLOTHING AWAY FROM ALL MOVING PARTS. • BELT AND CHAIN SHIELDS MUST BE IN PLACE BEFORE USING. • SHUT OFF ALL POWER BEFORE MAKING ANY ADJUSTMENTS OR PERFORMING ANY MAINTENANCE ON THIS UNIT. • DISCONNECT POWER BEFORE TAKING OFF GUARDS. </div>
PS-004	<div data-bbox="477 812 1421 1358" style="background-color: yellow; border: 1px solid black; padding: 10px;"> <p style="text-align: center; font-size: 2em; font-weight: bold; margin: 0;">! CAUTION</p> <ul style="list-style-type: none"> -TO ENGAGE OR DISENGAGE CLUTCH. -STOP THE MOTOR. -PULL CLUTCH ROD HANDLE IN OR OUT. -TURN PULLEY BY HAND (MOTOR MUST BE STOPPED) AND LISTEN FOR CLUTCH TO CLICK IN. <p style="text-align: center; font-weight: bold; margin: 0;"> OUT ←————→ IN </p> </div>
PS-005	<div data-bbox="485 1444 1421 1940" style="border: 1px solid black; padding: 10px;"> <div style="background-color: red; color: white; text-align: center; padding: 5px; font-weight: bold; font-size: 1.5em;"> ! DANGER </div> <div style="display: flex; align-items: center;"> <div style="flex: 1;">  </div> <div style="flex: 2; padding-left: 10px;"> <p style="font-weight: bold; margin: 0;">NEVER ENTER BIN</p> <p style="margin: 0;">UNLESS ALL POWER IS LOCKED OUT AND ANOTHER PERSON IS PRESENT.</p> <p style="margin: 0;">Exposed screw and moving parts can cause severe injury or death.</p> <p style="margin: 0;">Rotating augers are dangerous! Flowing grain may trap and suffocate.</p> <p style="font-weight: bold; margin: 0;">FAILURE TO HEED THIS WARNING MAY CAUSE SERIOUS INJURY OR DEATH.</p> </div> </div> </div>

3. Installation

Your Grain Saver™ Power Sweep System is completely assembled and is ready for installation in your new concrete foundation, or in your new existing conventional drying, natural air drying or other style aeration / drying system.

To install Power Sweep System in a concrete foundation:

- A. The Splined Gearbox Sweep output shaft is to be the center of the concrete foundation.
- B. Set the concrete forms, “stake” the tube in place using the leveling brackets provided on the Center Hopper to prevent “slip” and “float”.
- C. Check control rod sleeves to be certain that they were not bent in shipping or handling. This could cause difficulty in opening the wells. Straighten if necessary with a pry bar.
- D. The discharge end of the tube must be installed at least 1” lower than the intake end to prevent water build-up in the tube.
- E. Pour the concrete foundations to the bin manufacturer’s specifications and let “cure”.
- F. Install the sweep assembly with the one bolt “keeper” over the splined shaft.
- G. Adjust the sweep backboard to the length by loosening the 4 bolts and rotating the wheel so the sweep telescopes in or out to the desired location. Tighten the bolts. Sweep should also be adjusted on both the center and wheel end to ensure proper movement and operation. Make sure the sweep is not touching the bin floor at any point around the bin.
- H. Install Powerhead drive by inserting powerhead drive screw into unload screw and fasten them with the 2 provided bolts and tighten them. Then tighten the flange clamps on powerhead drive to flange on unload tube or u-trough. Adjust the unload screw on the spline of the center gearbox by loosening the insert bearing on the powerhead and sliding the unload screw and connected powerhead screw in or out so it is connected securely on the spline of the center gearbox. When properly set, There should be approximately 7/8” to 1” of spline showing from the gearbox plate to the unload screw spine.
- I. Install sweep safety stop on the inside of the bin wall right behind where the sweep will be parked when filling the bin, the sweep should be parked right over the sumps.

To Install Power Sweep System in Drying, Aeration or Full Floor Systems:

- A. Locate the area where the tube is to exit the bin wall. Using the rodent cover as a template cut the hole just large enough to allow for the tube and flange to pass through with minimal clearance. Be sure to allow for the handles and handle cover as well.
- B. Align the splined gearbox output shaft with the center of the bin.
- C. Check control rod sleeves to be certain that they were not bent in shipping or handling. This could cause difficulty in opening the wells. Straighten if necessary with a pry bar.
- D. Level the tube using the leveling brackets provided. Make sure that there is a 1" decline in the tube towards the discharge end or drill a 1/8" diameter hole in the center intake hopper bottom to allow for drainage.
- E. Install the Drying / Aeration floor to the manufacturer's specifications. Seal the area in the floor that was cut to fit around the hoppers with Grain Saver™ Hopper Flanges. Use self-drilling screws to attach this to the hopper
- F. Install the Grain Saver™ Bin Wall Plate over the tube and opening in the bin wall and attach with bolts or screws. The top half overlaps the bottom half by 1/2" to allow for proper watershed. Caulk any cracks or openings and fill corrugations with a good quality silicone or butyl based sealant.
- G. Install the sweep assembly with the one bolt "keeper" over the splined shaft.
- H. Adjust the sweep backboard to the desired length by loosening the 4 bolts and rotating the wheel so the sweep telescopes in or out to the desired length. Tighten the bolts. Sweep should also be adjusted on both the center and wheel end to ensure proper movement and operation. Make sure the sweep is not touching the bin floor at any point around the bin.
- I. Install Powerhead drive by inserting powerhead drive screw into unload screw and fasten them with the 2 provided bolts and tighten them. Then tighten the flange clamps on powerhead drive to flange on unload tube or u-trough. Adjust the unload screw on the spline of the center gearbox by loosening the insert bearing on the powerhead and sliding the unload screw and connected powerhead screw in or out so it is connected securely on the spline of the center gearbox. When properly set, There should be approximately 7/8" to 1" of spline showing from the gearbox plate to the unload screw spine.
- J. Install sweep safety stop on the inside of the bin wall right behind where the sweep will be parked when filling the bin, the sweep should be parked right over the sumps.

Note: If any warning or safety decals become lost or damaged in any manner, please contact us for free replacements. and the perforated floor. Caulk any cracks or openings with a good quality silicone or butyl based sealant.

4. Operation



Before continuing, ensure you have completely read and understood this manual's Safety section, in addition to the safety information in the section(s) below.

4.1. Operation Safety



WARNING • Keep away from rotating and moving parts, including the auger flighting, drive components, shafts, and bearings.

- Do not enter the grain bin while the bin unload is operating.
- Always operate with guards, covers, and shields in place.
- Have another trained person nearby who can shut down the equipment in case of accident.
- Keep the work area clear of bystanders.
- Keep the work area clean and free of debris.
- Ensure maintenance has been performed and is up to date.



Refer to your bin operation manual for specific operating and safety information for your bin.

4.2. Bin Unload Overview

The bin unload system operates by first opening the center sump to remove 70-80% of grain by gravity (see step 1 below). Next, the intermediate sumps are opened when the center sump runs empty to free the sweep (see step 2 below). Next, the bin sweep is operated to remove the remaining 20-30% of grain (see step 3 below). Lastly, the sweep is parked over the sumps for the bin to be refilled again.



WARNING To prevent serious injury or death from bin collapse, the center sump must be open first to empty bin.



NOTICE

Make certain there are adequate vents installed on the bin to prevent a vacuum from forming in the upper portion of the bin during unloading. The pressures on the roof caused by such a vacuum could damage or cause structural failure to the bin roof.

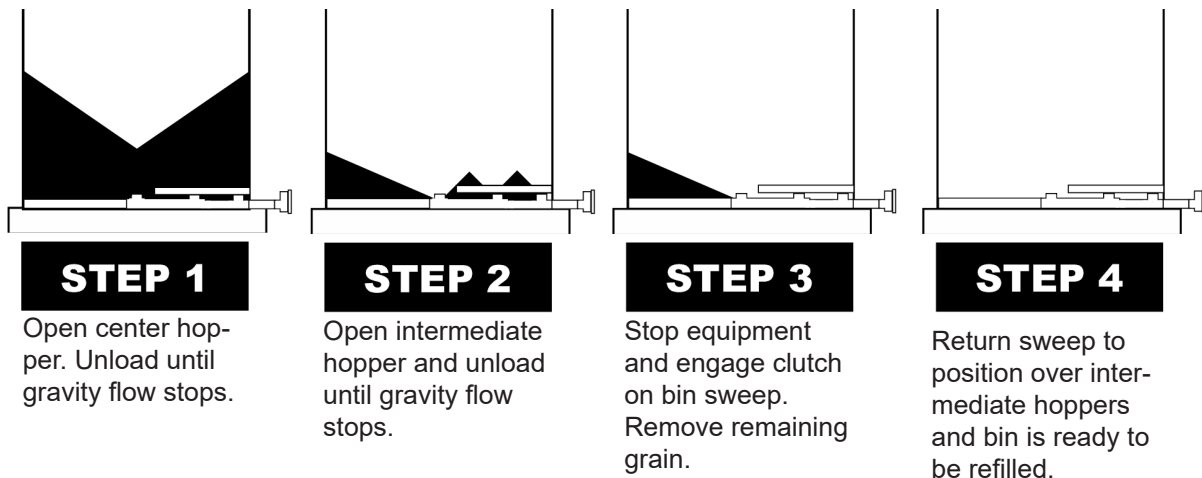

4.3. Before Filling the Bin with Grain

Following this list will prevent problems that may otherwise occur during the unloading process.

1. Lock out all power to bin and all equipment before servicing
2. Check for damage or unusual wear, especially on flighting, bearings, and drive wheel
3. Make sure there are no obstructions in the following locations:
 - sweep path along the bin floor bin sweep and underfloor auger flighting
 - center or intermediate sumps
4. Check all rollers and slides for free movement and oil liberally.
5. Prior to filling the bin each time, run the bin unload system to check for proper operation.
6. Close the center sump gate and intermediate sump gates.
7. Park the sweep in the “start/park position” slightly behind intermediate sumps prior to filling the bin each time.

NOTICE

Failure to park the sweep in the “start/park position” could result in damage to the sweep, under-floor conveyance system, and/or aeration floor.

8. Fill the bin from center opening to manufacturer’s specifications.
9. If Powerhead and Unload Screw are removed for storage, install rodent cap on end of tube.
10. If Powerhead is not removed, install supplied aeration cover over discharge spout with wing nuts.

4.4. Operation of the Powersweep system

Perform the following sections, in order, to fully unload the grain bin.

Unload Grain From the Center Sump

1. Disengage the bin sweep gearbox (push gearbox shift handle towards bin wall to disengage bin sweep).
2. Close all sump gates (center, emergency-sump (if equipped), and intermediate sumps).
3. Remove the rodent cap or aeration cover before operating the bin unload system.
4. Start system.
5. Rack & Pinion gate controls are set so the center well must be opened first. Read the instruction decal under the controls and open the gates in the sequence specified. Failure to follow this sequence could result in severe damage to the bin structure. When starting to unload open the center sump slightly. Ensure that grain flows out of the discharge end at a constant rate.
6. Continue to open the center sump and watch for constant product flow at discharge. Do this until center sump is fully open.
7. For the first 30 minutes, check that the underfloor auger flighting functions without excessive vibration. Once the grain mass has been fully drawn down, you are now ready to proceed with unloading grain from the intermediate sumps.

Unload Grain From the Intermediate Sumps

1. When grain flow from the center sump stops flowing from the discharge, open intermediate sump(s) half-way.
2. Monitor grain flow for consistency before opening intermediate sump(s) any further.
3. After grain has stopped flowing into intermediate sump(s), shut down and lock out all power to the bin unload system. Close all intermediate sump gates.

You are now ready to proceed with unloading grain with the bin sweep.

Unload Grain with the Bin Sweep

NOTICE

To prevent damage, do not operate the bin sweep until it is fully exposed.

1. Shut down and lockout all power to the bin unload system.

NOTICE

To prevent damage to the unload system, do not engage the binsweep while underfloor auger is operating.

2. Release the locking lever and engage the bin sweep (by shifting the lever away from bin wall). Lock the shift lever into place.
3. Start the bin unload system.
4. Make sure the center sump is fully open, and maintain a constant grain flow.
5. When grain flow stops and the bin is clean, raise the sweep stop for the bin sweep to complete a second pass. Park the bin sweep so it lines up next to the intermediate sumps.

NOTICE

Failure to park the bin sweep in the “start/park position” could result in damage to the bin sweep, underfloor auger, and/or aeration floor.

4.5. Emergency Shutdown

In an emergency situation:

1. Stop or shut down the power source immediately and lockout power.
2. Ensure the bin unload components come to a stop before inspecting.
3. Correct the emergency situation before resuming work.

4.6. Restarting with Full Underfloor Auger

When the bin unload system is shut down inadvertently or due to an emergency, the system may still be filled with grain.

1. Lock out power and remove as much of the grain as possible from the bin unload system using a grain vac or other tool.

WARNING Do not use your hands, feet, or other similar bodily means.

2. Once obstruction is clear, disengage sweep (if applicable). Remove locking pin, shift lever towards bin wall, and lock into place.
3. Close all intermediate sump gates, center and e-sump (if applicable) gate.
4. It may be necessary to tighten the drive belts slightly to handle the heavier than normal loads.
5. If guards or covers have been opened or removed, close or replace them before restarting the unit.
6. Once the problem is corrected, restart the machine.

NOTICE Starting under load may result in damage to the bin unload system if grain is not removed as much as possible.

7. Once the bin unload system has been started, you may resume normal operation.

4.7. Cleanup

1. Clean out any remaining grain with a grain vac, shovels, and/or brooms.
2. Clean up (remove) all settled dust deposits.

WARNING Buildup of dust inside the grain bin and around the bin sweep and underfloor auger could lead to a dust explosion if not removed regularly.

4.8. Extended Shutdown / End of Season

After the season's use, the bin unload should be thoroughly inspected. Repair or replace any worn or damaged components and complete maintenance as described in the next section to prevent any unnecessary downtime at the start of the next season.

5. Maintenance



Before continuing, ensure you have completely read and understood this manual's Safety section, in addition to the safety information in the section(s) below.

5.1. Maintenance Safety

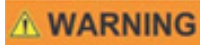

- Keep components in good condition. Follow the maintenance procedures.
- Ensure the service area is clean, dry, and has sufficient lighting.
- Do not modify any components without written authorization from the manufacturer. Modification can be dangerous and result in serious injuries.
- Shut down and lock out power before maintaining equipment.
- After maintenance is complete, replace all guards, service doors, and/or covers.
- Use only genuine Grain Saver replacement parts or equivalent. Use of unauthorized parts will void warranty. If in doubt, contact Grain Saver or your local dealer.
- Before applying pressure to a hydraulic system, make sure all components are tight and that hoses and couplings are in good condition.

5.2. Maintenance Schedule

Proper maintenance habits mean a longer life, better efficiency, and safer operation. Please follow the Maintenance Schedule below. Keep good records of the hours the bin unload has been operated and the maintenance performed.

Daily:
Section 5.3 – Visually Inspect the Equipment
Monthly:
Section 5.4 – Inspect Hydraulic Hoses and Fittings
Annually:
Section 5.5 – Clean and Wash the Equipment
Section 5.6 – Check the Gearbox Oil
As Required:
Section 5.7 – Change the Gearbox Oil
Section 5.8 – Tension the Drive Belts
Section 5.9 – Align the Drive Belts
Section 5.10 – Replace the Drive Belts
Section 5.11 – Replace the Sweep Drive Wheel
Section 5.12 – Adjust the Bin Sweep Backboard
Section 5.13 – Removing the Underfloor Auger Flighting

5.3. Visually Inspect the Equipment

 **WARNING** Lock out power before inspecting.

Check the following during a visual inspection:

1. Ensure all guards are in place and in good working order.
2. Examine the Powersweep for damage or unusual wear.
3. Check tightness of bolts/nuts, fasteners, and hardware (re-torque if necessary).
4. Be sure all safety decals are in place and are legible.
5. Check that the discharge and intake area are free of obstructions.
6. Inspect all moving or rotating parts to see if anything has become entangled in them. Remove any entangled material.
7. When equipped: Inspect hydraulic hoses and fittings for leaks and wear. Fix or replace where necessary.

5.4. Inspect Hydraulic Hoses and Fittings

--When equipped:

1. Pressurize the system.
2. Using a piece of cardboard or wood, run it along the length of the hose and around all fittings.

 **WARNING** Escaping hydraulic fluid under pressure will cause serious injury if it penetrates the skin surface.

3. Replace the hose or tighten/replace the fitting if a leak is found.
4. Replace any hose that is badly cut, nicked, abraded, or is separating from the crimped end of the fitting.
5. Secure hoses to the machine.

5.5. Clean and Wash the Equipment

1. Clean out excess grain from all areas of the equipment.
2. Wash the unload auger that extends outside of the bin with a water hose or pressure washer until all dirt, mud, debris, or residue is gone.
3. Provide sufficient time for the equipment to dry.

5.6. Check the Gearbox Oil

1. Remove sweep from lower gearbox
2. Remove access panel at center to expose lower gearbox.
3. Remove vent plug to check gearbox oil level.
4. Maintain oil level at half full (center of cross shaft) with 90W or equivalent gear oil, adding as necessary.
5. Ensure gearbox is level when checking or refilling.
6. Do not overfill when adding oil.
7. Replace vent plug.
8. Replace access panels when complete.
8. Follow same procedure dor sweep gearbox.

5.7. Change the Gearbox Oil

Use SAE approved 90W or equivalent gear oil.

1. Remove gearbox from the bin unload.
2. Place a pan under the drain plug.
3. Use a wrench and remove the drain plug.
4. Loosen the filler plug so air can enter the gearbox and the oil will drain freely.
5. Allow the oil to drain completely.
6. Replace the drain plug.
7. Add oil until the gearbox is half full (center of cross shaft) and replace filler plug. A flexible funnel may be required. Gearbox should be level when checking or refilling. **Do not overfill.**
8. Reinstall the gearbox and guards.

5.8. Tension the Belt Drive

1. Remove guard and push on the center of the belt span with a force of approximately 5 lb. The belts will deflect approximately 1/2" (13 mm) when properly tensioned.
2. Tighten or loosen the drive belts (or idler pulley when equipped) to achieve the proper tension.

Important

The drive belt should be just tight enough to not slip on the drive pulley when operating. If the belt is too loose, it will slip, possibly causing a squeaking sound and slowing the belt down. If the belt is too tight, it will cause excess wear.

3. The belt tension can be adjusted by moving the belt tensioner notch up or down on the motor mount plate.
4. Reattach and secure guard. Start system to ensure proper operation.

5.9. Align the Drive Belts

1. Lay a straight edge across the pulley faces to check the alignment.
2. Use the pulley hub to move the pulley to the required position for alignment.
3. Tighten the hub bolts to secure pulley on the drive shaft.
4. Check the belt tension.
5. Reattach and secure the guard.

5.10. Replace the Drive Belts

1. Remove the guard.
2. Fully loosen the drive belts.
3. Remove and replace the old belts.
4. Tighten the drive belts as described in Belt Tension.
5. Align the drive belts as described in Belt Alignment.
6. Reattach and secure the guard.

5.11. Replace the Sweep Drive Wheel

When equipped with a direct drive wheel:

1. Remove the bolt that attaches the direct drive wheel to the sweep auger.
2. Slide the wheel off the shaft from the end of the sweep auger.
3. Replace with a genuine Grain Saver or certified drive wheel.

When equipped with a reduction drive wheel:

1. Remove the 2 bolts that attach the drive wheel unit to the end of the sweep auger
2. Remove the 3 bolts that attach the gear wheel to the backboard extension
3. Follow the steps below to replace the rubber tread on the reduction drive wheel

Replacing the drive wheel rubber tread:



Tools Needed:

- Two 1/2" wrench
- One 1-1/8" wrench
- Flat Blade Screw driver for front plate removal

5.12. Adjust the Bin Sweep Backboard

The bin sweep backboard should not normally require adjustment. The backboard can be adjusted in cases where the bin sweep is leaving grain on the bin floor or if the backboard gets stuck on the bin floor. To adjust, loosen the bolts/nuts (1, 2) as shown in the below figures, then tilt the backboard up or down to the desired height. Tighten bolts/nuts after adjusting.

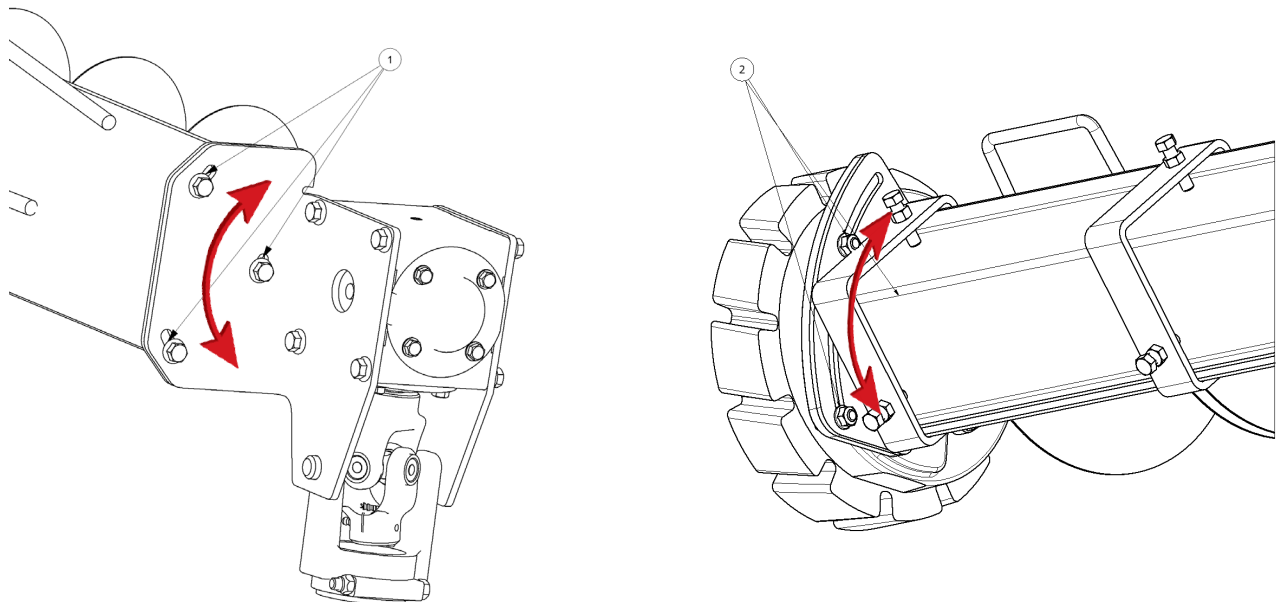

5.13. Removing the Underfloor Auger Flighting

In certain circumstances (such as general maintenance or troubleshooting), it may be required to remove the underfloor auger flighting

To Remove the Flighting:

1. Shut down and lock out power to the powersweep system.
2. Release the belt tensioner from the motor plate to disengage the belts. Remove the belts and pulley.
3. Remove the motor plate with attached motor from the head drive unit by releasing the lock from the mounting pin and then lifting the motor plate with motor off the drive unit.
4. Release the 8 bolts that attach the head unit to the underfloor unit.
5. Release the 2 bolts that attach the drive shaft to the underfloor auger.
6. Pull out the auger flighting from the underfloor unit.

To Reinstall the Flighting:

1. Push the flighting back into the underfloor auger
2. Attach the drive shaft from the head unit back onto the underfloor auger with the 2 bolts. Make sure the insert bearing is loosened on the drive unit for adjustment of the underfloor flighting
3. Push the underfloor auger into the unload unit, rotating the auger slightly to ensure the splined coupler lines up with the splined shaft on the lower gearbox by the center sump.
4. Attach the head drive unit to the underfloor unit and tighten the 8 bolts
5. Make sure the underfloor flighting is adjusted and set properly onto the lower gearbox spline. To do this, measure the lower gearbox spline shaft from the gearbox plate to the end of the coupler on the underfloor auger. There should be approximately 7/8" to 1" of the spline shaft exposed. Adjust if needed.
6. Tighten the insert bearing on the head drive unit. Re-attach the motor plate with motor onto the drive unit. Install the pulley and belts and adjust the tension as described in Section 5.8.
7. Ensure belt guard is installed.

6. Troubleshooting

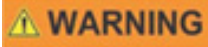

WARNING Shut down and lock out all power sources before diagnosing any of the causes or attempting any of the solutions below

In the following section, we have listed some causes and solutions to some of the problems you may encounter.

If you encounter a problem that is difficult to solve, even having read through the section, please contact your local dealer or distributor.

Problem	Cause	Solution
Gearbox won't engage sweep	Gearbox shift lever isn't adjusted correctly	Adjust lever to proper position
	Unload auger isn't set on spline correctly	Loosen insert bearing on powerhead and push screw onto gearbox spline
Gearbox won't stay engaged	Lock pin not in place	Secure lock pin in place
Hopper slide gates are difficult to open	Hopper slide plates are damaged	Replace metal slide plates
	Obstruction in hopper	Remove obstruction
	Rack & pinion controls are damaged	Replace rack & pinion controls
Sweep will not function	Underfloor auger not engaging lower gearbox spline	Ensure underfloor auger spline coupler is fully inserted on lower gearbox spline
	Shift gearbox not engaged	Engage it
	Obstruction in sweep	Remove obstruction
Underfloor auger plugs when initially starting sweep	Intermediate hoppers aren't closed	Close intermediate hoppers
	Obstruction in underfloor auger	Remove obstruction
Sweep drive wheel doesn't function when sweep is activated	Drive wheel bolts aren't in place	Ensure all bolts are in place and tightened that attach the sweep drive wheel to the sweep auger
	Obstruction in sweep	Remove obstruction

Problem	Cause	Solution
Sweep stops travelling around the bin	<p>Sweep isn't adjusted correctly and is hitting a high spot on the aeration floor</p> <p>Sweep drive wheel isn't functioning properly (stripped gears, sheared bolts, loose bearing that holds sprocket in place etc...)</p> <p>Drive wheel rubber is worn down</p> <p>Obstruction in sweep</p>	<p>Adjust sweep in 2 places: Drive wheel and upper gearbox plate</p> <p>Ensure all bolts are in place and tightened, sprocket and gears are in place and not stripped, bearing is tightened.</p> <p>Replace rubber drive wheel or rubber treads</p> <p>Remove obstruction</p>
Poor product flow from sweep	<p>Sweep is touching floor or drive wheel is not adjusted properly</p> <p>Obstruction in sweep</p> <p>Damaged or bent flighting</p>	<p>Adjust sweep and ensure drive wheel is in working condition</p> <p>Remove obstruction</p> <p>Repair or bend flighting back to original shape. If this doesn't work, replace flighting</p>
Underfloor auger is unable to move the grain that the sweep is dumping into the center hopper	<p>Obstruction in center hopper</p> <p>Intermediate hoppers are open, flooding the underfloor auger</p> <p>Flighting is not timed correctly on the underfloor auger</p>	<p>Remove obstruction</p> <p>Close intermediate hoppers</p> <p>Pull out underfloor flighting, ensure that it is timed correctly (flighting must make a continuous spiral)</p>
Underfloor system stops when moving product	<p>Electric motor belts are not tight enough</p> <p>Electric motor is not large enough to power entire system</p> <p>Obstruction in underfloor auger</p>	<p>Tighten belts</p> <p>Replace electric motor with a larger model</p> <p>Remove obstruction</p>
Grain is flowing over backboard of sweep	<p>This is normal, and the grain will be swept up on the second pass of the sweep</p>	<p>No solution needed. Part of normal operation</p>

Problem	Cause	Solution
Sweep will not turn or is noisy	This is normal, and the grain will be swept up on the second pass of the sweep	No solution needed. Part of normal operation
Sweep is knocking	Gearbox adjustment is incorrect	Check to ensure adjustment is correct and gearbox is fully engaged
Belt is moving, motor is running, but sweep and underfloor auger are not moving	Set screws and keys on pulleys are not installed or are too loose	Disengage system and check set screws and keys to ensure they are installed and tightened
Sweep engaged, underfloor auger and motor running, but sweep flighting and/or upper gearbox not turning	Underfloor gearbox shift linkage is out of adjustment Underfloor auger is not connected properly on spline Spline shaft on lower gearbox is broken Sheared bolts and/or key on upper gearbox where sweep coupler is connected Upper gearbox shaft is broken Gearbox is damaged	Adjust shift linkage to fully engage sweep Ensure underfloor auger is fully inserted on lower gearbox spline Replace broken spline shaft or the lower gearbox Replace bolt and key that connect the sweep top the gearbox Replace gearbox shaft or complete gearbox Replace gearbox
Sweep engaged and running, but not advancing	Sweep catching on Tek screws (backboard or gearbox) Backboard catching on bin floor Rubber on wheel wore down Grain condition wet, hard-packed, moldy End wheel contacting bin wall	Ensure Tek screws are fully screwed down Ensure backboard clearance is at 1/4"-1/2" from floor Replace with new rubber drive wheel Sweep will perform poorly if grain is out of condition Adjust sweep away from bin wall

Problem	Cause	Solution
Underfloor flighting is noisy	<p data-bbox="581 163 1039 241">Flighting connection to power-head shaft is loose</p> <p data-bbox="581 315 1039 392">Center gearbox spline connection is not straight</p> <p data-bbox="581 430 1039 472">Flighting is bent</p>	<p data-bbox="1058 163 1523 283">Remove flange connector bolts and pull out the flighting and ensure all hardware is tightened</p> <p data-bbox="1058 315 1523 392">Ensure gearbox is set straight into the u-trough</p> <p data-bbox="1058 430 1523 619">Remove underfloor flighting. Check for straightness by rolling across flat concrete area. Straighten or replace as necessary</p>

7. Specifications

7.1. Mechanical

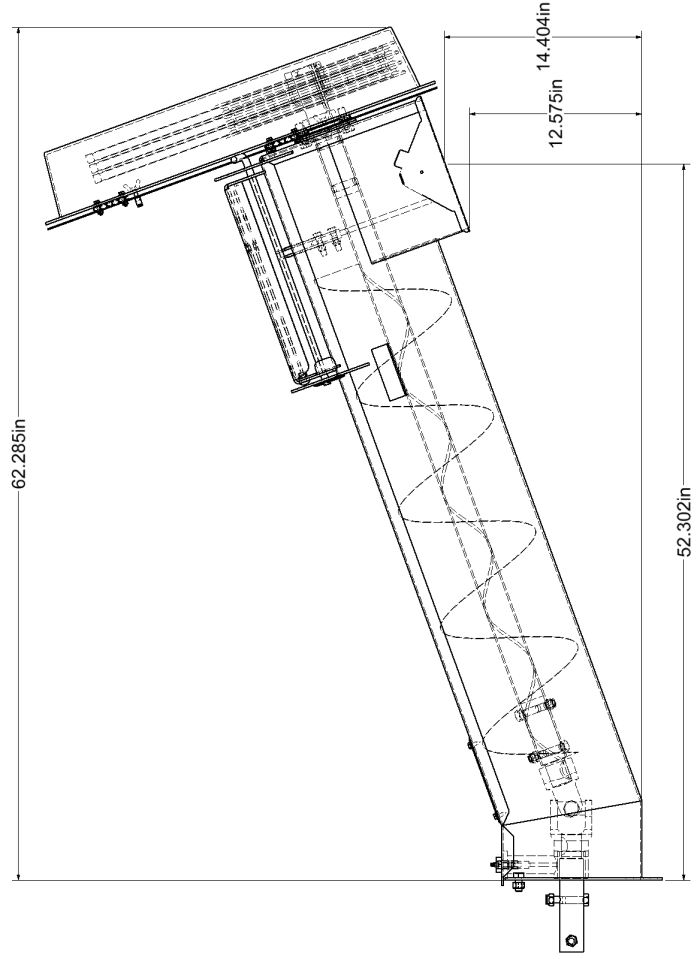
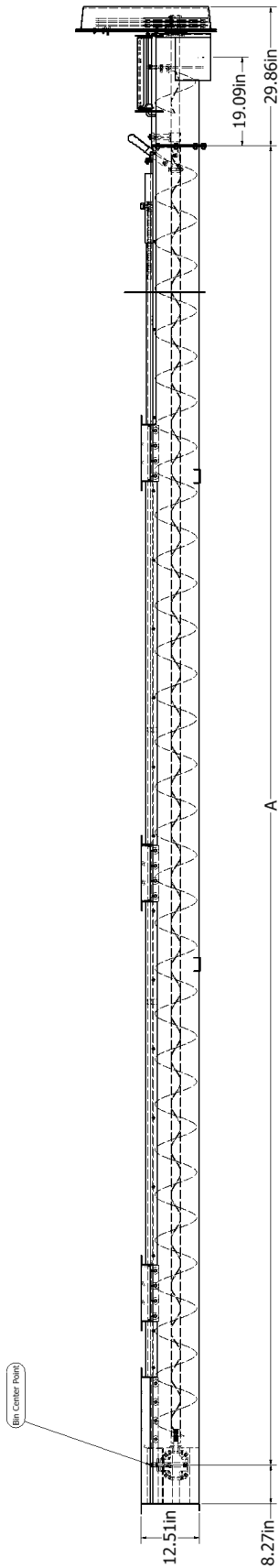

Powersweep Model (Bin Diameter)	Dimension "A"
19'	139"
21'	154"
24'	172"
27'	191"
30'	210"
33'	227"
36'	247"
39'	268"
42'	284"
45'	302"
48'	330"
54'	357"
60'	396"
68'	442"
72'	466"
75'	484"
78'	502"

7.2. Power Requirements

Electric Motor Requirements

Powersweep model (Bin Diameter)	System Horsepower (HP) Requirements with sweep			
	8" Unload (7" Sweep Flighting)		10" Unload (7" Sweep Flighting)	
	Horizontal Powerhead	Incline Powerhead	Horizontal Powerhead	Incline Powerhead
19'-24'	5	7.5	7.5	10
27'-33'	7.5	10	7.5	15
36'-39'	7.5	10	10	15
42'-45'	10	10	10	15
48'-51'	10	15	15	15
54'-60'			20	20

Recommended Pulley Size Combinations

Unload Pulley	Drive Motor Pulley	Pulley Type		Belt Size	Flighting Speed (RPM)
		8" Unload	10" Unload		
	8" & 10" Unload	8" Unload	10" Unload	8" & 10" Unload	8" & 10" Unload
14"	3.5"	Double Groove	Triple Groove	B56	440
14"	3.75"	Double Groove	Triple Groove	B56	468
19"	3.5"	Double Groove	Triple Groove	B68	320
19"	3.75"	Double Groove	Triple Groove	B68	345

U-trough Unloader with Sweep			
3.5" Motor Pulley and 14" Flight Pulley			
Motor		RPM	Capacity (Bushels Per Hour)
		1750	
Unload	8"	440	3750
	10"		5280
Sweep		294	2200

U-trough Unloader with Sweep			
3.75" Motor Pulley and 14" Flight Pulley			
Motor		RPM	Capacity (Bushels Per Hour)
		1750	
Unload	8"	468	4000
	10"		5650
Sweep		312	2340

U-trough Unloader with Sweep			
3.5" Motor Pulley and 19" Flight Pulley			
Motor		RPM	Capacity (Bushels Per Hour)
		1750	
Unload	8"	320	2750
	10"		3850
Sweep		214	1600

U-trough Unloader with Sweep			
3.75" Motor Pulley and 19" Flight Pulley			
Motor		RPM	Capacity (Bushels Per Hour)
		1750	
Unload	8"	345	2950
	10"		4150
Sweep		230	1725

Flighting Speed is calculated using a 1750 rpm electric motor. To determine flighting speed (rpm), divide the motor speed (rpm) by the outside diameter of the large unload pulley, then multiply by the outside diameter of the small motor pulley. Example: $1750 \text{ rpm} / 14" \times 3\text{-}3/4" = 468 \text{ rpm}$.

If a slower flighting speed is desired, install a smaller motor pulley.

LIMITED WARRANTY

HAVEN INDUSTRIES, hereinafter is referred to as "Agent". The manufacturers of The Grain Saver® Auger Equipment warrant each Grain Saver® product to be free from defects in material and workmanship for a period of twelve (12) months. The "defects" must be reported to the manufacturer, the "Agent", or to the "Agent's" representatives within the 12 month warranty period commencing on the date of the original sale.

This limited warranty is made expressly in lieu of all other warranties, whether expressed or implied but not limited to, warranties of merchantability and fitness for a particular purpose, and of all other obligations or liabilities on the part of the "Agent". The customer's rights and remedies are governed exclusively by the terms and conditions of this limited manufacturer's warranty, and the customer expressly waives for himself, and any subsequent purchaser, any claim based upon contract, tort, strict liability, or otherwise.

"Manufacturer's" obligation and sole remedy under this warranty is exclusively limited, at "manufacturer's" option, to either repair or replace any part or product found to be "defective" providing that such part or product be returned to the "Agent's" place of business in Dexter, Minnesota, Transportation Charges Prepaid, or to the selling dealer or distributor's place of business from whom the purchase was made. All corrective work on products must be approved in writing by "Agent" prior to such repairs. No allowances will be made for corrective work that has been completed without this expressed approval.

Improper lubrication, improper installation, deterioration by chemical action, and premature wear caused by the presence of abrasive material does not constitute "defects".

This warranty shall not render "Agent" liable for any consequential damages including, and without limitation to; personal injury, expenses of removing the product, loss or damage resulting to the equipment or structure(s) in which the "Manufacturer's" products have been installed, loss of such equipment or structure, loss of commodity, or loss of profits.

This warranty shall be declared null and void immediately if the purchaser or the representative of the purchaser, or anyone else shall modify or install, or cause to be modified or installed replacement parts not sold, distributed, or approved by the "Manufacturer".

This warranty shall not be extended to gearboxes, batteries, drive belts, tires, inner tubes, electrical controls, or any purchased component that carries its own manufacturer's warranty. The warranty on these products shall be limited only to the term of the published warranties on these products.

Manufacturer is not responsible for installation of the product, and is not liable for any loss or damage attributed to any improper installation.

"Agent" neither assumes nor authorizes anyone to assume for "Agent", any liabilities in connection with the sale of its products.

All claims under this limited warranty must be presented in writing within 30 days of the date of assumed failure to: HAVEN INDUSTRIES 67374 310th St. Dexter, Minnesota 55926. Failure to do so will result in customer's claim being waived and not enforced.

This warranty is subject to existing conditions of supply, which may directly affect the ability of the "Manufacturer" to obtain materials or manufactured replacement parts.

Customer agrees to incorporate the terms of this warranty into any subsequent sale or transfer of these products to a third party such that the "Agent's" liability shall be expressed, limited to the terms and conditions of this limited warranty, as well as the choice of law and choice of jurisdiction provisions of this agreement. If any party brings any action against the "Agent", for other than those set forth in this limited warranty against any such claims and/or judgments thereon. In no event shall the "Agent's" liability extend beyond the terms and conditions of the warranty provided to the "Agent's" original customer.

Customer agrees that Customer's rights and responsibilities, in regard to this transaction, shall be governed by the laws of the state of Minnesota and shall be the exclusive jurisdiction for bringing any dispute in regards to this transaction.

Customer acknowledges that he is knowledgeable concerning the goods purchased from the "Agent". Customer has reviewed the limited warranty and that the remedies provided are adequate and acceptable to the customer. "Agent" is not responsible or liable for any claim of personal injury or death.



Haven Industries



PHONE: 507.584.6300 • FAX: 507.584.0215 • www.havenindustries.us • DEXTER, MN
55926