

3532

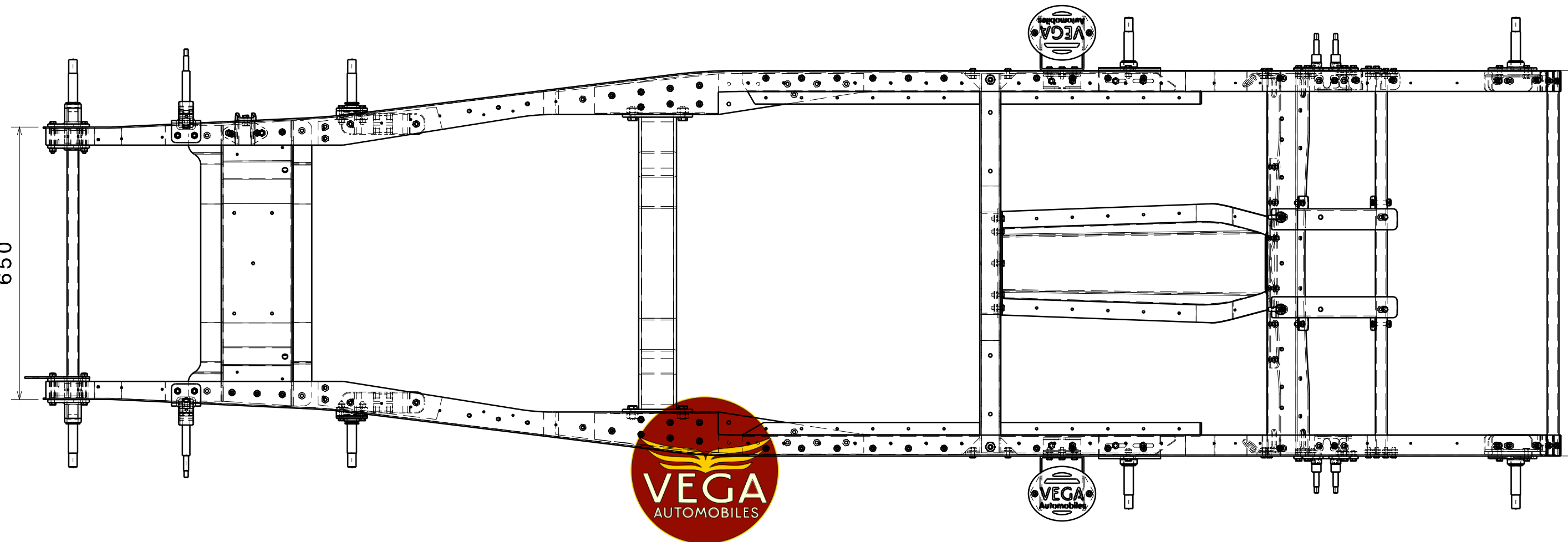

650

920

This drawing is our property. It can't be reproduced or communicated without our written agreement.



1931 MONZA SPECIALE

DRAWN BY GCO - Vega	DATE 21/10/2020
CHECKED BY GCO - Vega	DATE same
DESIGNED BY GCO - Vega	DATE same

DRAWING TITLE			
TELAIO MONZA (MONZA FRAME)			
SIZE A3	DRAWING NUMBER P-1100	REV 03	
SCALE	- WEIGHT (kg) -	SHEET	1 / 4

4

4

3

3

2

2

1

1

H

G

B

A

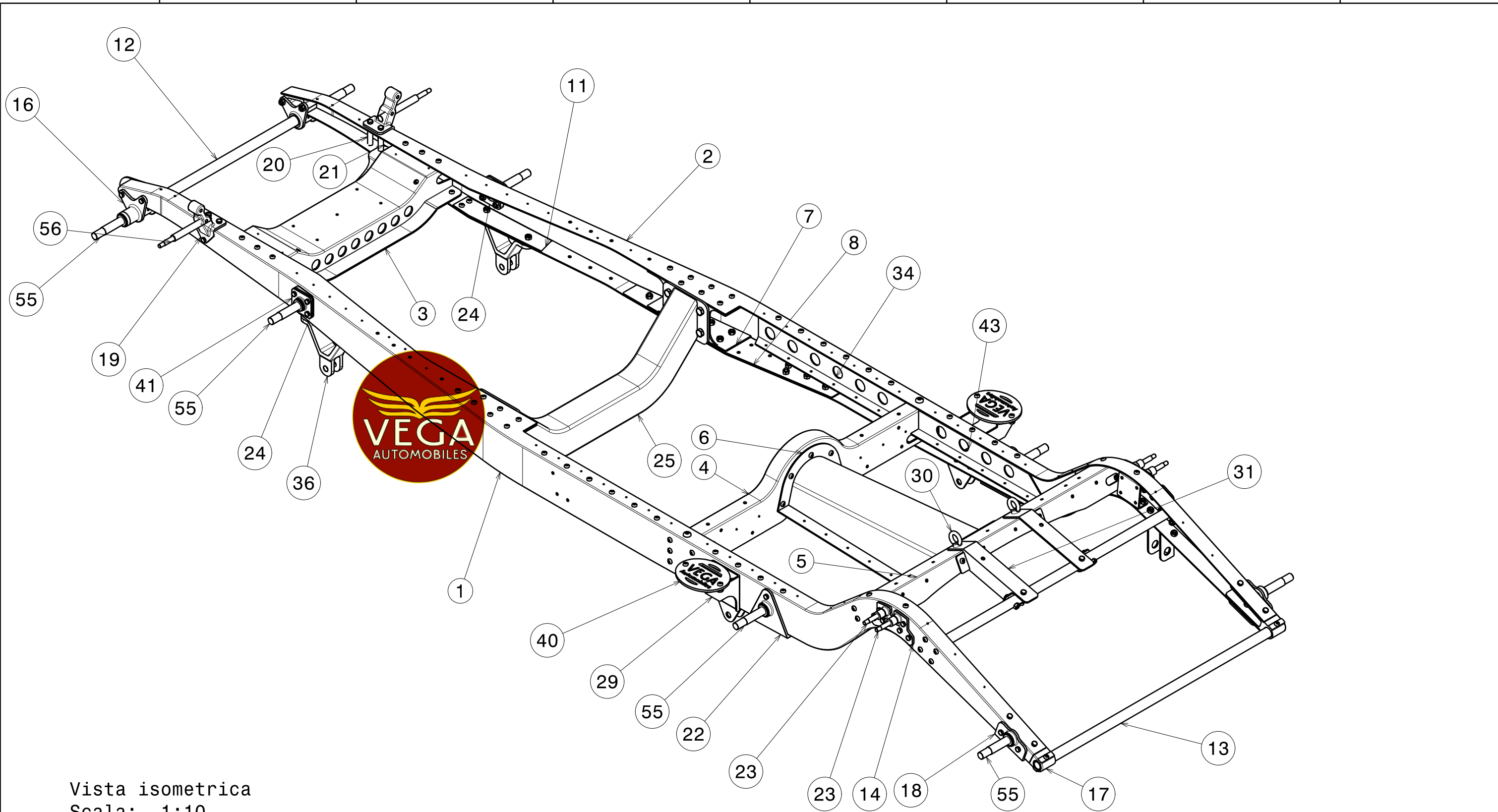

Vista isometrica
Scala: 1:10



This drawing is our property. It can't be reproduced or communicated without our written agreement.				1931 MONZA SPECIALE	
DRAWN BY GCO - Vega					
CHECKED BY GCO - Vega		DATE same		SIZE A3	DRAWING NUMBER P-1100
DESIGNED BY GCO - Vega		DATE same		SCALE - WEIGHT (kg) -	REV 03
				SHEET 2/4	

4
3
2
1

4
3
2
1

H G F E D C B A

H G F E D C B A

4

4

3

3

2

2

1

1

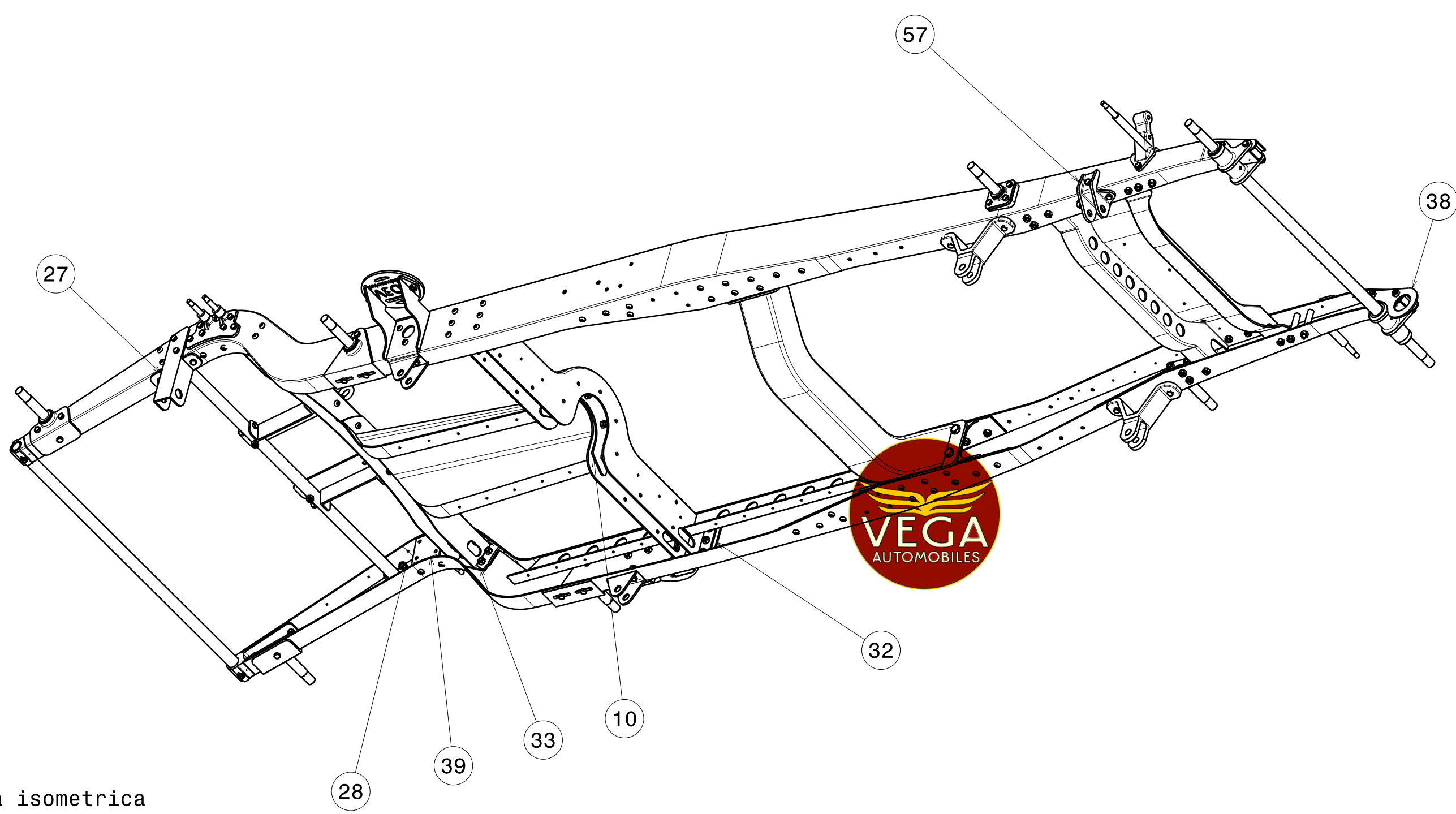

Vista isometrica
Scala: 1:10

This drawing is our property. It can't be reproduced or communicated without our written agreement.				<h2>1931 MONZA SPECIALE</h2>		
DRAWN BY GCO - Vega	DATE 21/10/2020			DRAWING TITLE <h3>TELAIO MONZA (MONZA FRAME)</h3>		
CHECKED BY GCO - Vega	DATE same	SIZE A3	DRAWING NUMBER P-1100	REV 03		
DESIGNED BY GCO - Vega	DATE same	SCALE -	WEIGHT (kg) -	SHEET 3/4		

H G B A

Rif.	Codice e denominazione	Q.ta'
1	P-1101 Longherone SX	1
2	P-1102 Longherone DX	1
3	P-1103 Traversa radiatore	1
4	P-1104 Traversa trasmissione	1
5	P-1105 Traversa serbatoio	1
6	P-1106 Tunnel trasmissione	1
7	P-1107 Staffe motore	2
8	P-1108 Piastra staffa motore	1
9	P-1109 Rinforzo traversa serbatoio	1
10	P-1111 Piastra rinforzo traversa trasmissione	1
11	P-1115 Rinforzo braccio oscillante	2
12	P-1124 Magnone anteriore	1
13	P-1125 Magnone posteriore	1
14	P-1127 Attacco posteriore ammortizzatori	2
15	P-1128 Blocchetto anteriore	2
16	P-1129 Blocchetto magnone anteriore	2
17	P-1130 Blocchetto magnone posteriore	2
18	P-1131 Attacco posteriore balestra posteriore	2
19	P-1133 Torretta ammortizzatore anteriore	2
20	P-1134 Distanziale anteriore trespole ammortizzatore	2
21	P-1135 Distanziale posteriore trespole ammortizzatore	2
22	P-1136 Staffa anteriore balestra posteriore	2
23	P-1137 Perno ammortizzatore posteriore	4
24	P-1138 Cuneo attacco posteriore balestra anteriore	4
25	P-1119 Cassa di torsione	1
26	P-1120 Tubo supporto serbatoio carburante	1
27	P-1121 Supporto Panhard	1
28	P-1122 Attacco tubo sostegno serbatoio carburante	2
29	P-1123 Supporto predellino e tiranteria posteriore	2
30	P-1132 Attacco centrale cinture	2
31	P-1110 Binario serbatoio carburante	2
32	P-1113 Piastra rinforzo trasmissione	2
33	P-1114 Attacco cinture sicurezza	2
34	P-1159 Correntino anteriore pianale	2

Rif.	Codice e denominazione	Q.ta'
35	P-1160 Correntino posteriore pianale	2
36	P-1161 Supporto puntoni assale anteriore	2
37	VITE TESTA ESAGONALE M8 x 90	4
38	P-1162 gancio traino anteriore	1
39	P-1220 Zampa gabbia posteriore	2
40	P-1163 Predellino	2
41	P-1164 Piastra perno posteriore balestra anteriore	2
42	VITE TESTA ESAGONALE M8 x 20	21
43	DADO M8	193
44	VITE TESTA ESAGONALE M8 x 40	12
45	VITE TESTA ESAGONALE M8 x 30	4
46	VITE TESTA ESAGONALE M8 x 70	4
47	VITE TESTA BRUGOLA M8x20	110
48	VITE TESTA ESAGONALE M8 x 25	20
49	VITE TESTA ESAGONALE M12 x 25	16
50	DADO M12	10
51	VITE TESTA BRUGOLA M8 x 55	2
52	VITE TESTA BRUGOLA M8x25	15
53	VITE TESTA BRUGOLA M12x25	2
54	DADO M10	2
55	P-1170 Perno telaio grillo	8
56	P-1152 Perno torretta ammortizzatore	2
57	P-1141 Staffa barra Panhard anteriore	1

This drawing is our property. It can't be reproduced or communicated without our written agreement.				<h2>1931 MONZA SPECIALE</h2>					
DRAWN BY GCO - Vega				DATE 21/10/2020		DRAWING TITLE <h3>TELAIO MONZA (MONZA FRAME)</h3>			
CHECKED BY GCO - Vega		DATE same		SIZE A3		DRAWING NUMBER P-1100		REV 03	
DESIGNED BY GCO - Vega		DATE same		SCALE -		WEIGHT (kg) -		SHEET 4/4	