

Set-up Instructions

1980 Model ATC 185



AMERICAN HONDA MOTOR CO., INC.
100 WEST ALONDRA BOULEVARD, GARDENA, CALIFORNIA 90247

WARNING

WARNING

WARNING

WARNING

SET-UP AND PRE-DELIVERY SERVICE MUST BE PERFORMED BY AN AUTHORIZED HONDA MOTORCYCLE DEALER. Proper set-up and pre-delivery service is essential to rider safety and reliability of the motorcycle. When a customer takes delivery of his brand new motorcycle, he expects it to be in excellent running condition. There are few things that will cause greater customer dissatisfaction than poor preparation of a new motorcycle. An error or oversight made by the mechanic assembling and servicing a new unit can easily result in faulty operation, damage to the machine, or even injury to the rider.

NOTE: The black vertical bars near the edge of the pages as shown here, indicate changes. Read carefully.



NOTE: Right and left are determined from the rider's view.

SET-UP INSTRUCTION

REVISED PAGES

Pages Affected	Orig. Issue Date	Rev. Date
1 through 21	10/79	Original
1, 2, 3, 10, 13, 13A added, 20	10/79	4/80

Remove and destroy superseded pages.

This page supersedes page 2 dated 10/79. Remove and destroy superseded page.

Rev. 4/80

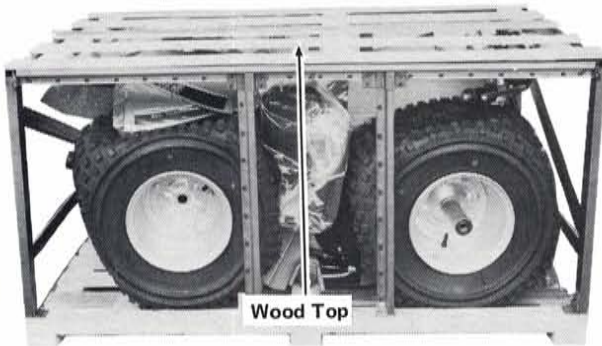
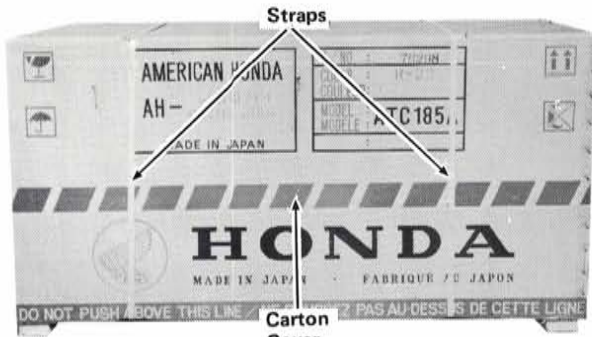

STEP 1—Cut straps and remove carton cover by lifting it up. Remove crate wood top.

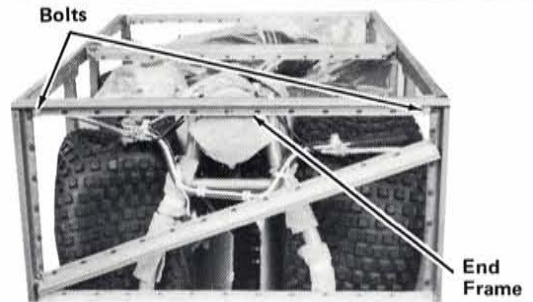

LATER CRATING

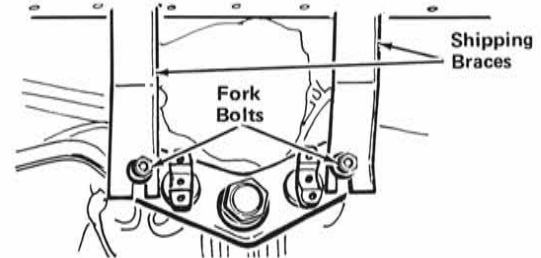

STEP 2—Remove two bolts attaching crate front end frame to steel crate top. Discard bolts. Later crates will have two additional shipping braces. On these crates, loosen two fork bolts to remove crate. Retighten fork bolts to specified torque.

Torque specification:
4.4 kg-m (32 lb-ft)

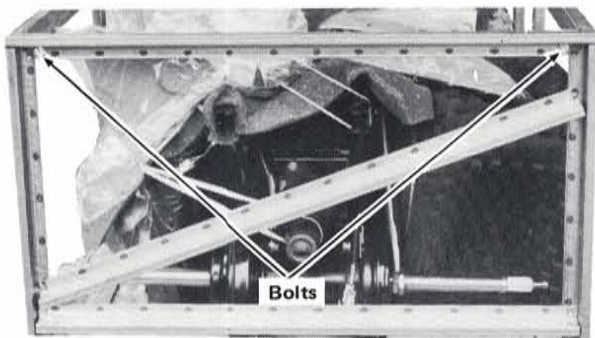

LATER CRATING

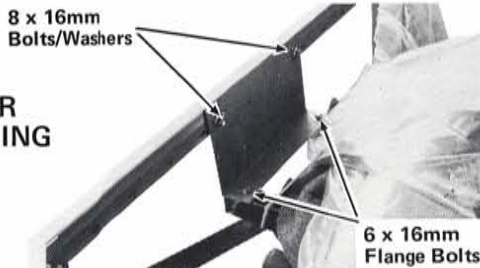

STEP 3—Remove two bolts attaching crate rear end frame to steel crate top. Discard bolts. (Later crates will have an additional two 6 x 16mm flange bolts and two 8 x 16mm bolt/washer combinations. Retain these bolts.) Discard metal crate top.

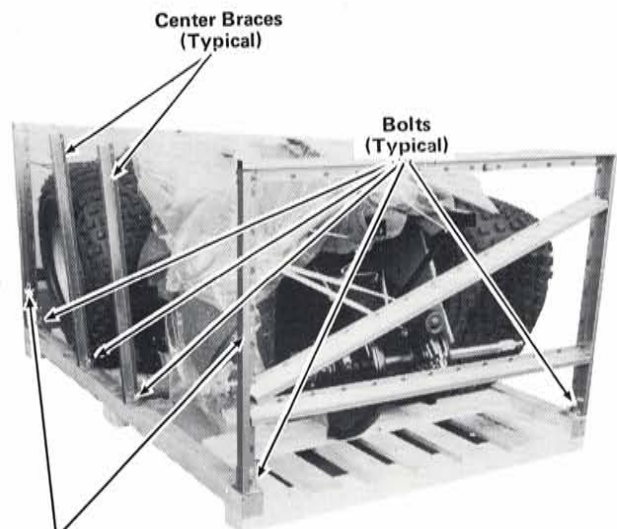

End Frames

STEP 4—Remove bolts attaching crate end frames and center braces to crate base. Discard end frames, center braces, and bolts.

NEW NEW NEW NEW NEW

This page intentionally left blank.

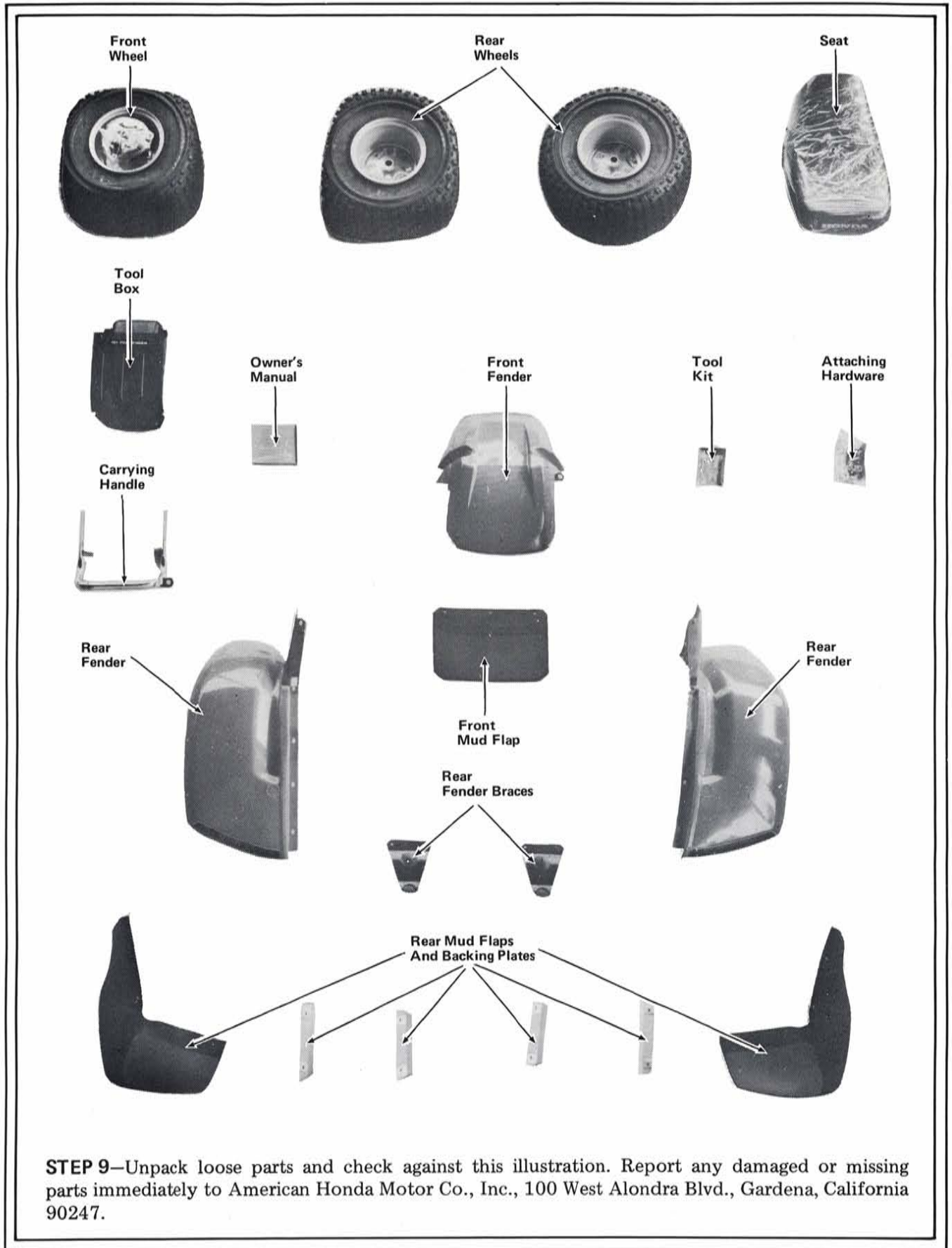

STEP 9—Unpack loose parts and check against this illustration. Report any damaged or missing parts immediately to American Honda Motor Co., Inc., 100 West Alondra Blvd., Gardena, California 90247.

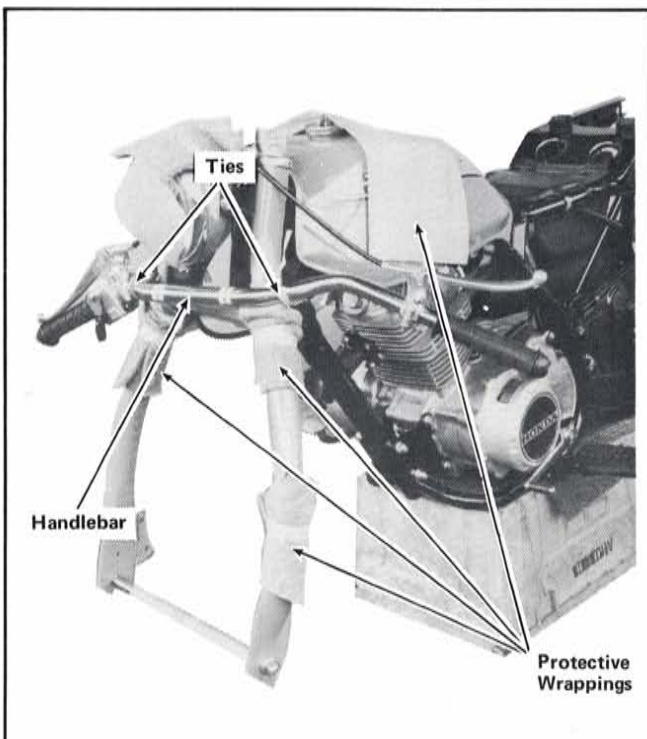

STEP 10—Remove ties holding handlebar to front forks. Remove all protective wrappings from front forks, headlight, and fuel tank.

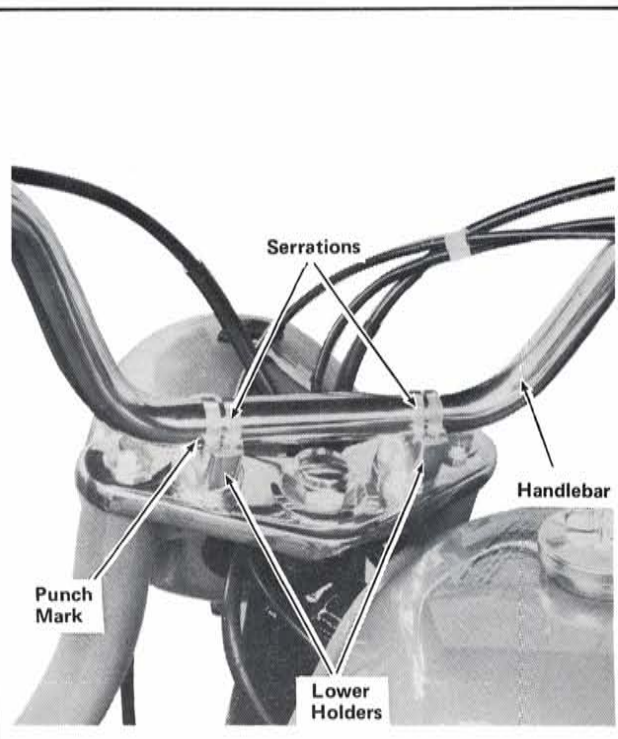

STEP 11—Position handlebar on lower holders with serrations aligned with holders and punch mark on handlebar aligned with top of holders.

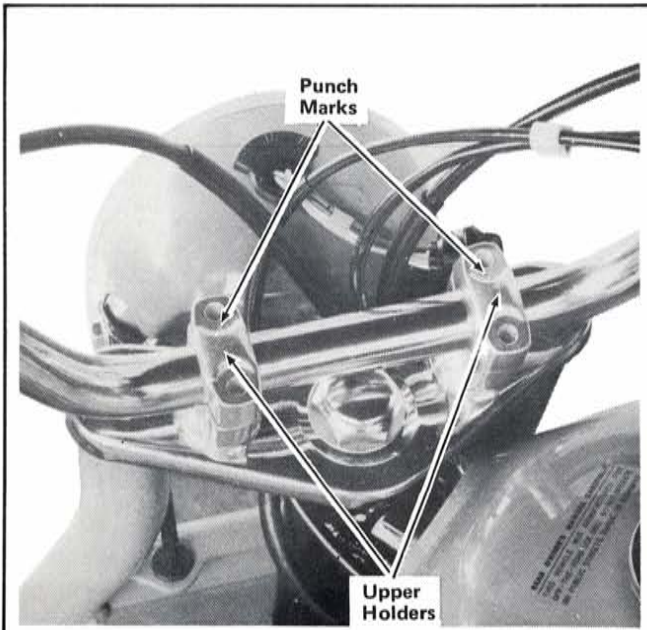

STEP 12—Position upper holders on handlebar with punch marks on holders forward.

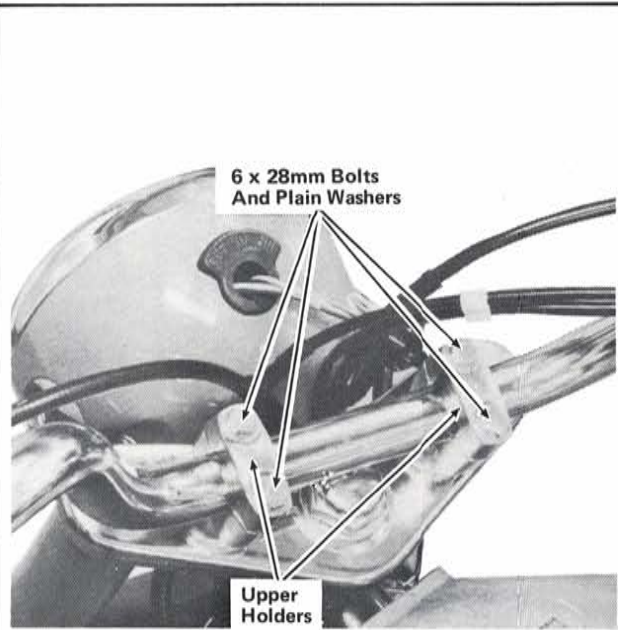

STEP 13—Install upper holders using four 6 x 28mm bolts and plain washers. Tighten forward bolts to specified torque first, then tighten rear bolts to same torque.

Torque specification:
1.0 kg-m (8 lb-ft)

STEP 14—Install light switch in headlight case by aligning groove in switch with lug on rubber grommet and pushing down on switch.

STEP 15—Check front fender mud flap and attaching hardware.

STEP 16—Position mud flap under front fender as shown and install using three 6 x 8mm special screws inserted down through fender, and special nuts under fender as shown. Tighten screws securely.
NOTE: Note direction of special nuts.

STEP 17—Position front fender between fork legs with mud flap towards the rear, and install using four 6 x 16mm bolts and flanged washers as shown. Tighten bolts to specified torque.
Torque specification:
1.0 kg-m (8 lb-ft)

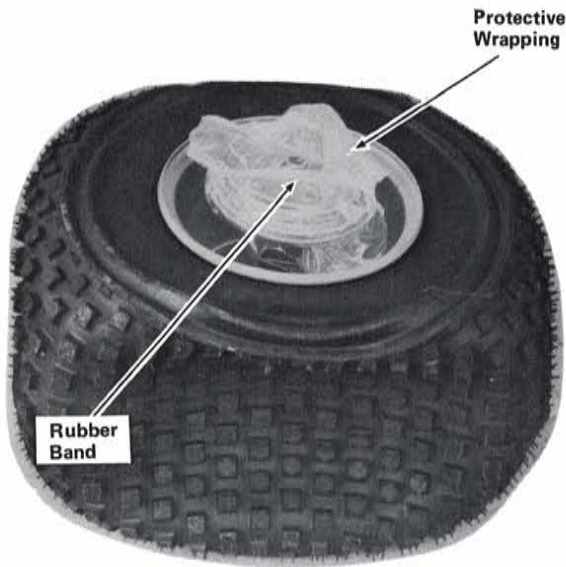

STEP 18—Remove rubber band and remove protective wrapping from front brake. Remove front brake and check that brake linings and brake drum are clean. Check that grease seal is full of grease. If necessary, wipe brake drum with a clean cloth.

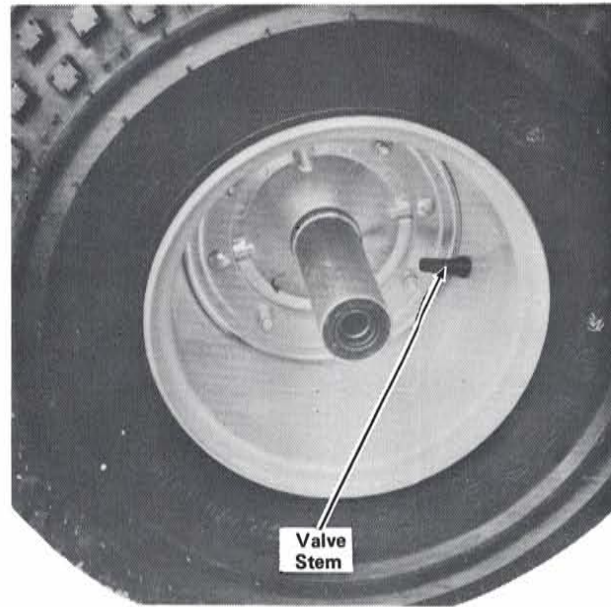

STEP 19—Inflate and check tire pressure of all three tires.

Tire Pressure: 2.2 psi.

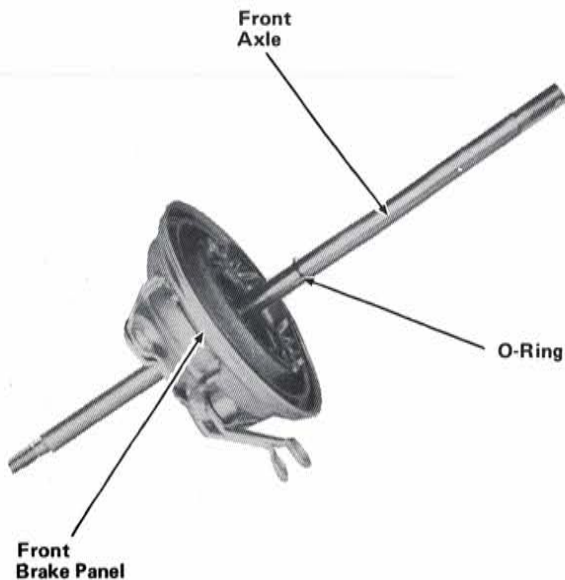

STEP 20—Slide front axle through front brake panel and slip an o-ring over axle from brake shoe side as shown.

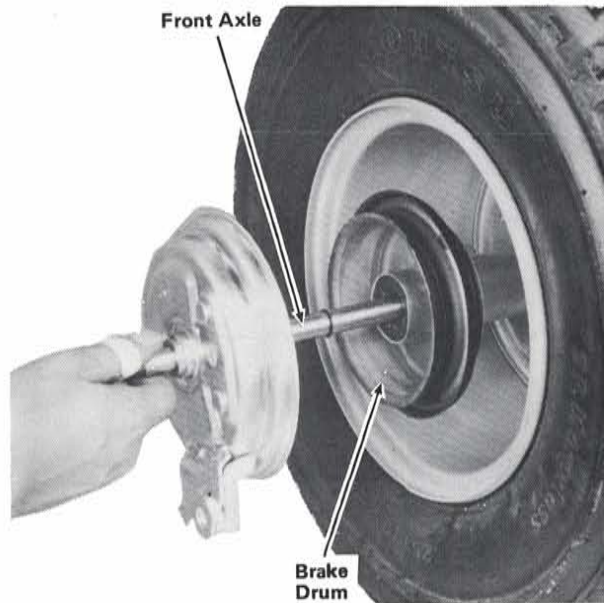

STEP 21—Insert front axle through front wheel hub from brake drum side as shown.

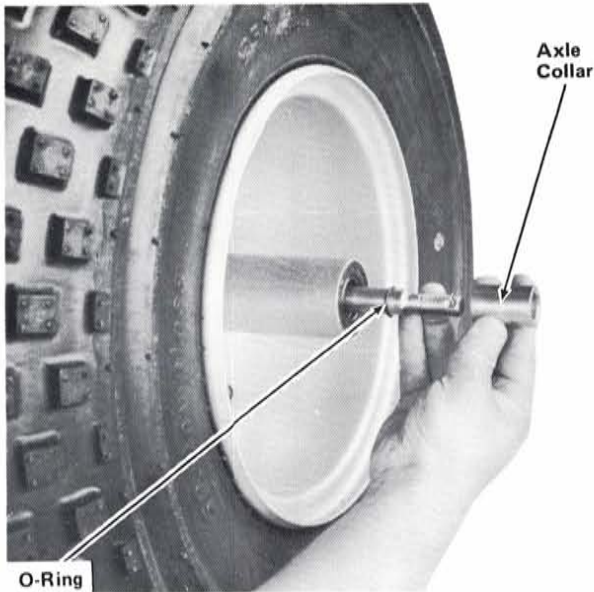

STEP 22—Slip an o-ring and axle collar over front axle from valve stem side as shown.

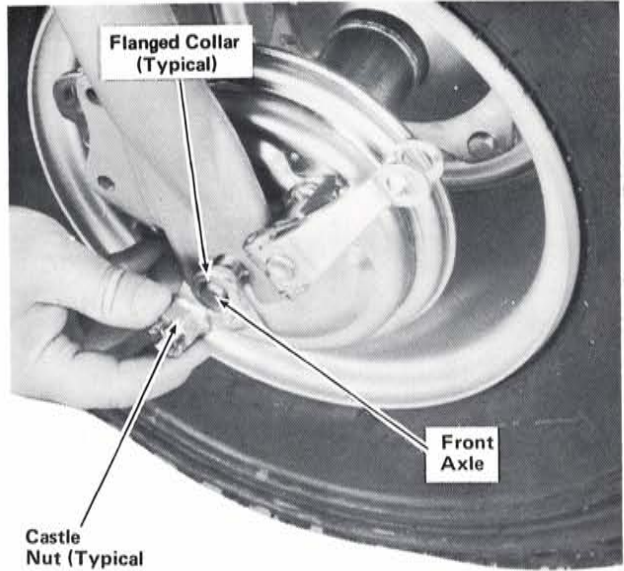

STEP 23—Install a flanged collar and castle nut on each end of front axle. Do not tighten nuts at this time.

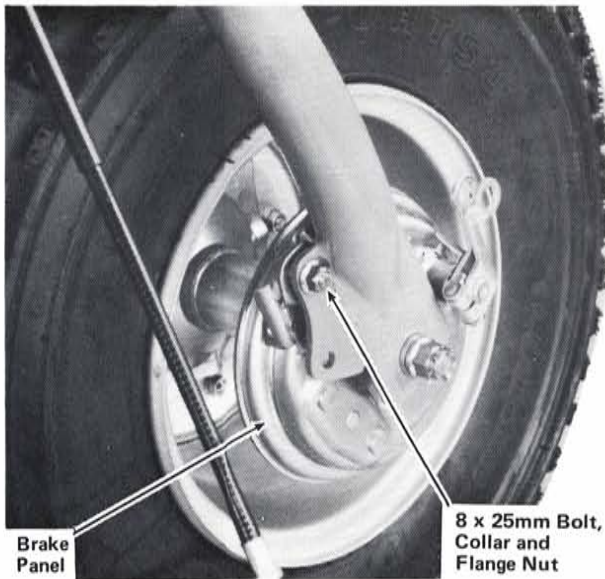

STEP 24—Attach front brake panel to right fork leg using an 8mm bolt, collar, and flange nut, with collar between brake panel and fork leg. Tighten securely. Nut is on outside.

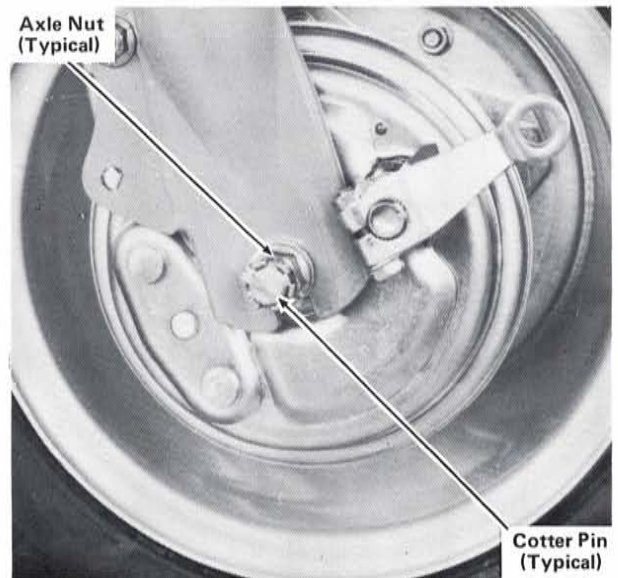

STEP 25—Tighten both axle nuts equally to specified torque. Install a cotter pin in each and spread ends of cotter pins as shown.

Torque specification:
6.0 kg-m (44 lb-ft)

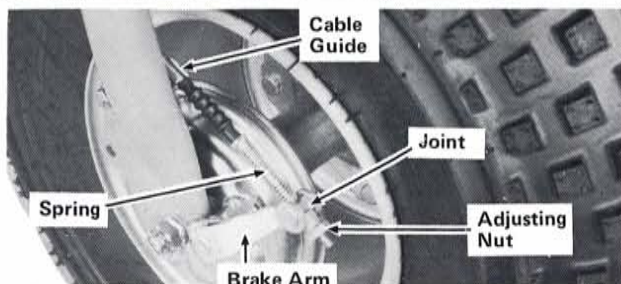
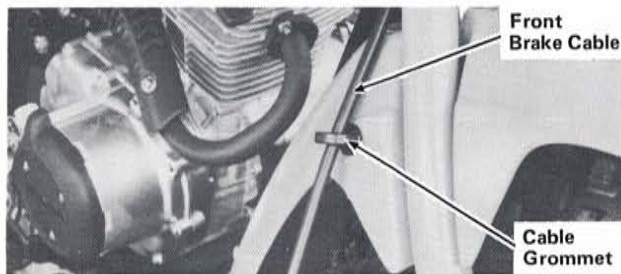

STEP 26—Route front brake cable down through cable guide (later models), cable grommet on front fender, and through cable guide on brake panel. Slip brake return spring over end of brake cable and connect cable to front brake arm using a brake arm joint and cable adjusting nut. Adjust front brake as described in Step 47.

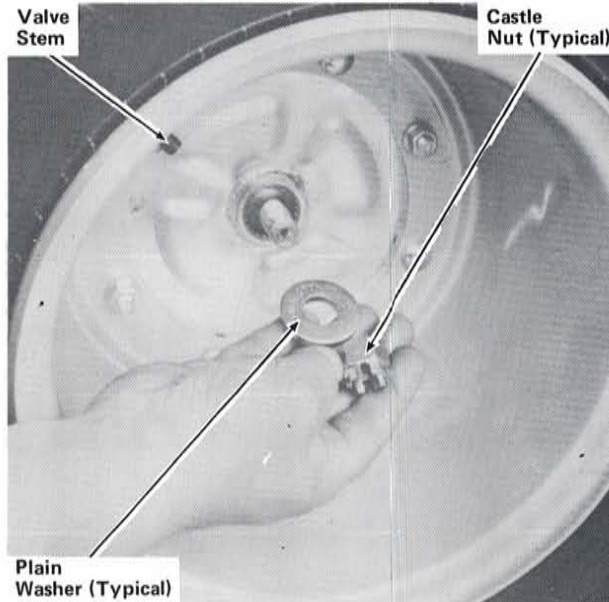

STEP 27—Grease rear axle splines and install rear wheels, with valve stems to the outside, using a plain washer and castle nut for each.

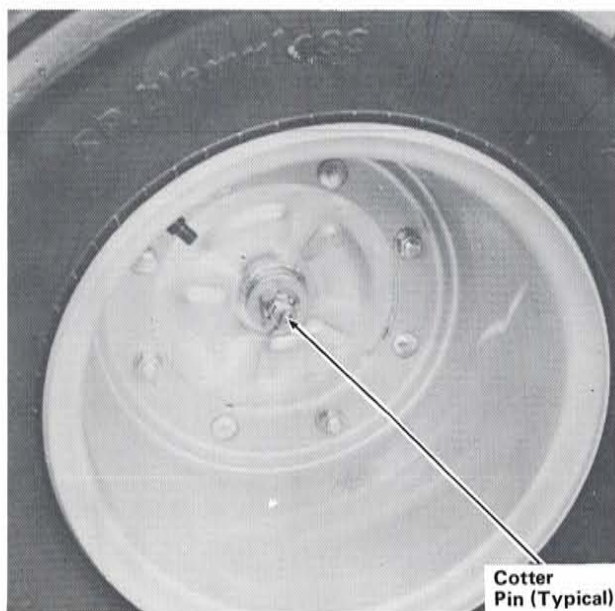

STEP 28—Tighten both axle nuts to specified torque and install a cotter pin in each. Spread ends of cotter pins as shown.

Torque specification:
7.0 kg-m (51 lb-ft)

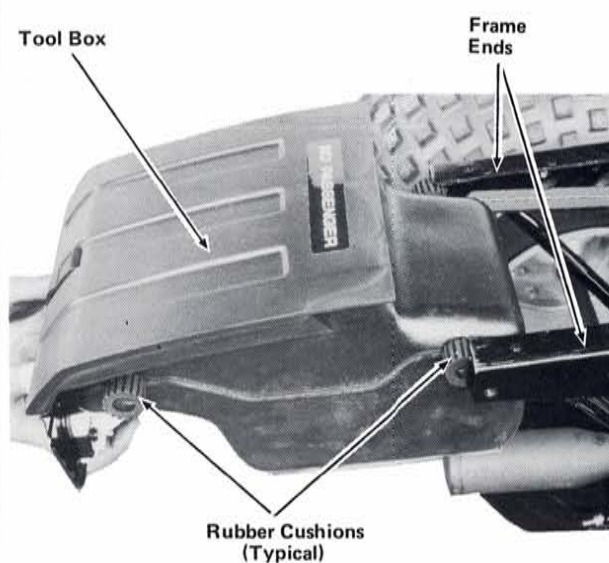

STEP 29—Position tool box between rear frame ends as shown and slide it forward all the way.

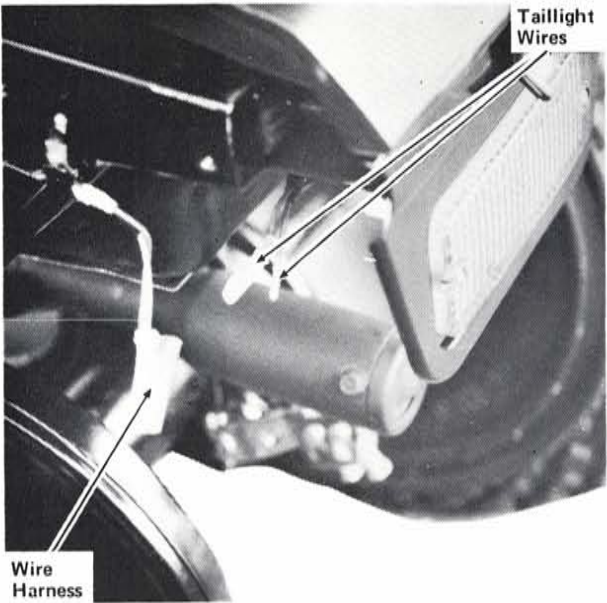

STEP 30—Connect taillight wires to wire harness color-to-color.

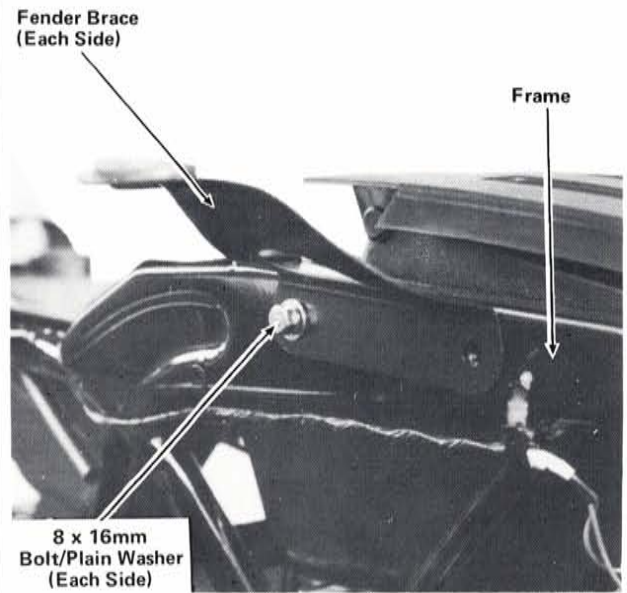

STEP 31—Position right and left fender braces on frame as shown and install using an 8 x 16mm bolt/plain washer through forward hole of each.

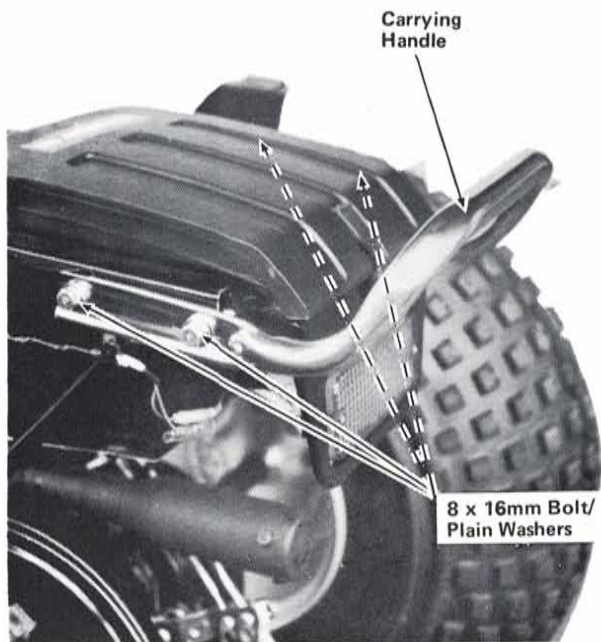

STEP 32—Position ends of carrying handle over rear holes of fender braces as shown and install using two 8 x 16mm bolt/plain washer combinations for each side. Tighten all six 8mm bolts securely.

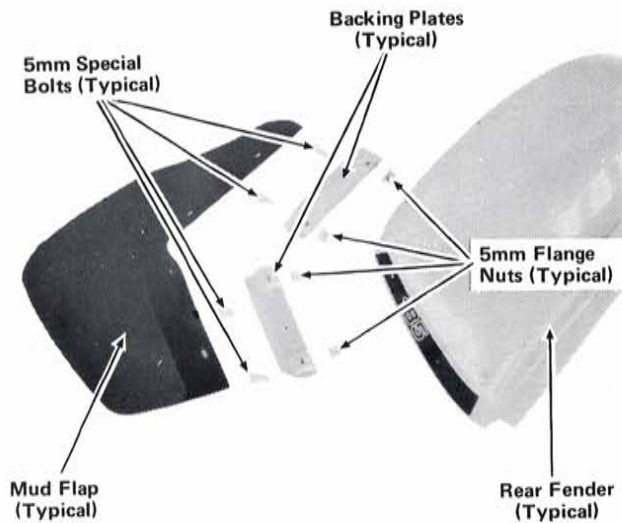

STEP 33—Check rear fenders, mud flaps, and attaching hardware.

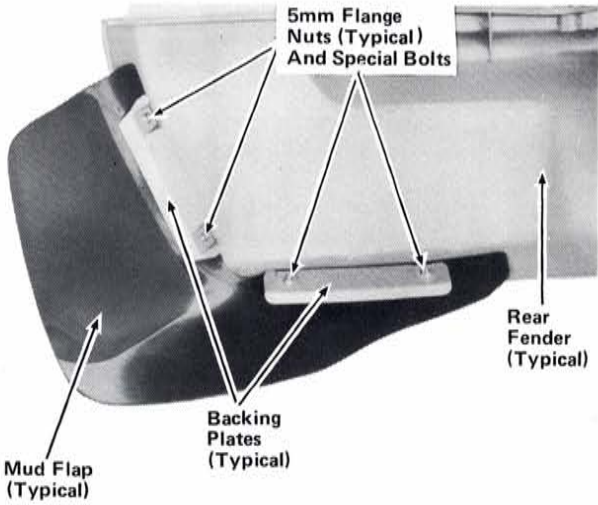

STEP 34—Position rear mud flap under rear fender and install using four 5mm special bolts inserted down through fender, and two backing plates and four flange nuts under fender as shown. Repeat for other fender. Tighten all screws securely.

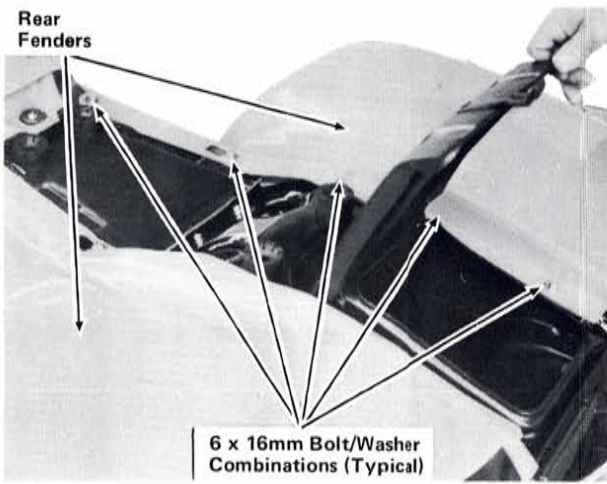

STEP 35—Position right and left rear fenders on frame as shown and install using five 6 x 16mm bolt/washer combinations and collars for each fender.



STEP 36—Attach front lower portion of each fender to frame using a 6 x 16mm bolt/washer combination. Tighten all 12 6mm fender bolts securely.

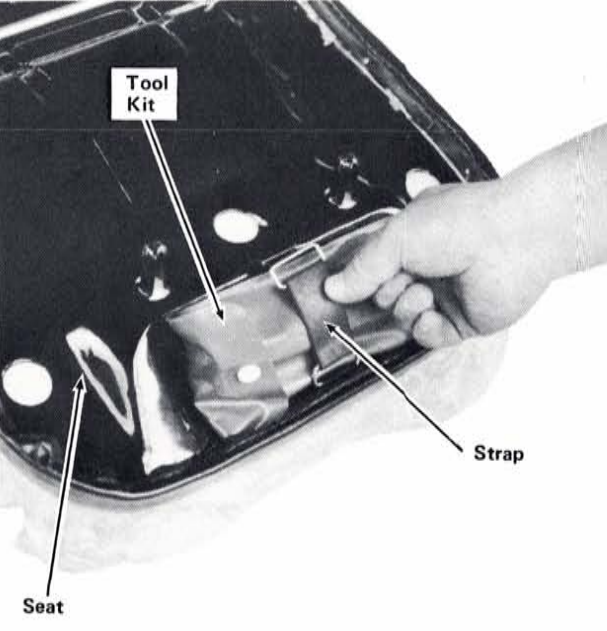

STEP 37—Place tool kit in tool compartment under seat and secure with strap as shown.

FRONT BRAKE CABLE ROUTING PRIOR TO FRAME NO. 2018431

THROTTLE CABLE ROUTING PRIOR TO FRAME NO. 2014760

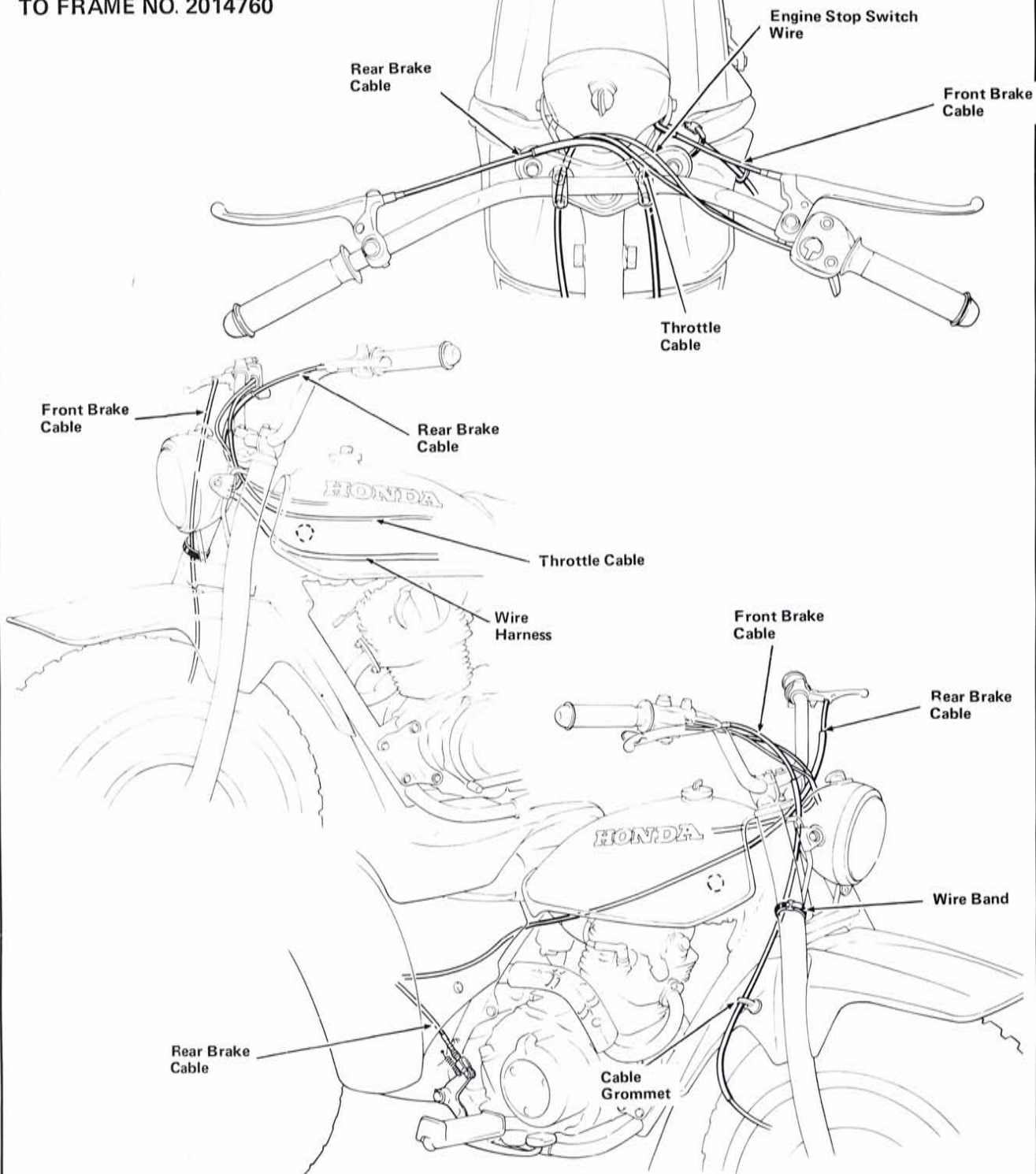

STEP 38—Check routing of front and rear brake cables, throttle cable, and engine stop switch wire as shown.

FRONT BRAKE CABLE ROUTING—
FRAME NO. 2018431 AND LATER

THROTTLE CABLE ROUTING—
FRAME NO. 2014760 AND LATER

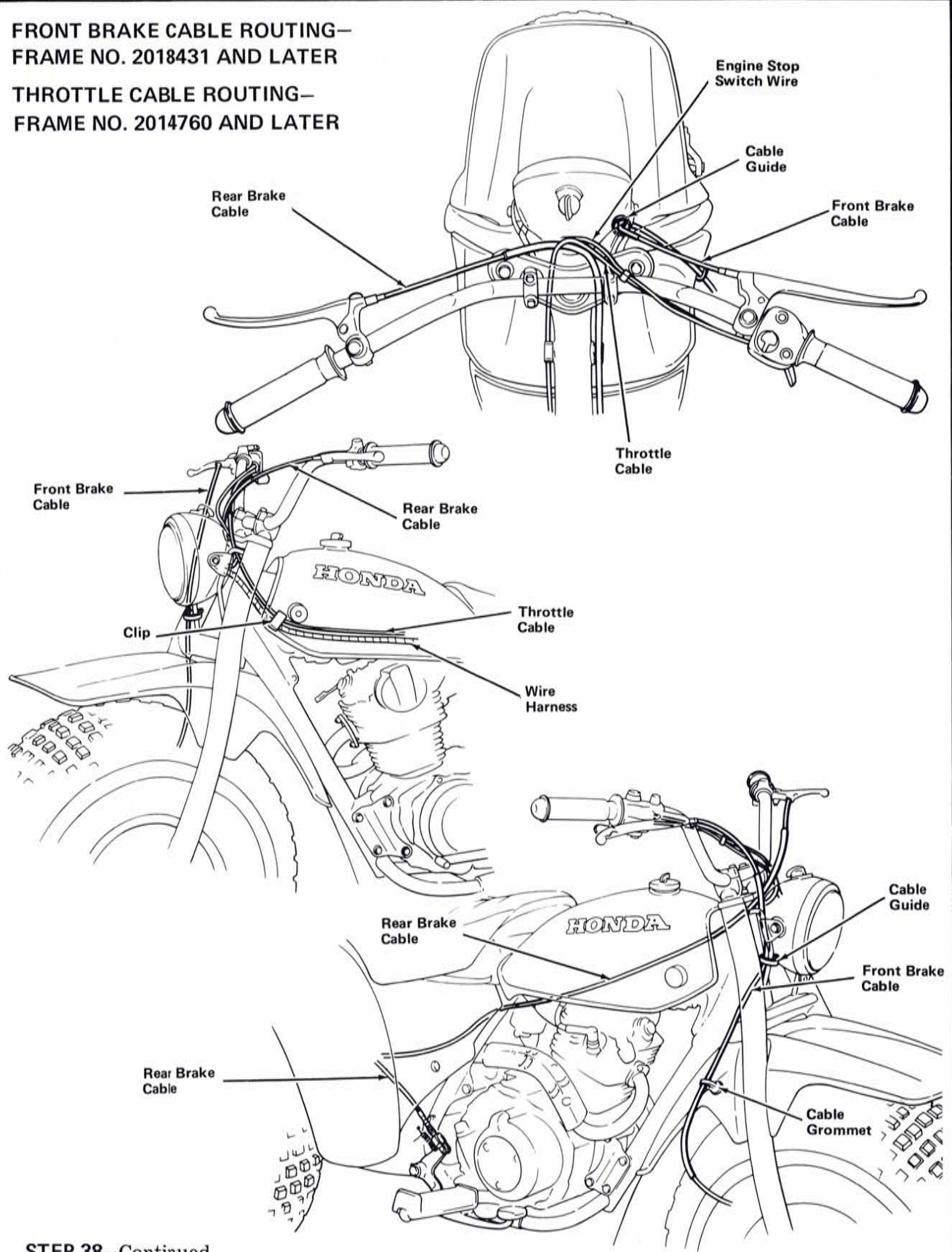

STEP 38—Continued.

This page intentionally left blank.



STEP 39—Remove crankcase drain plug and drain engine oil. Reinstall and tighten drain plug to specified torque.
NOTE: Not required if less than 4 months have elapsed since date of manufacture shown on identification plate on steering head.
 Refill crankcase with recommended oil as described in owner's manual.

Torque specification:
 1.2 kg-m (9 lb-ft)

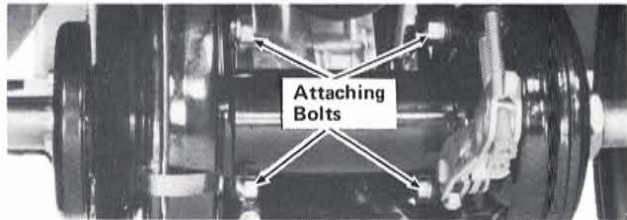
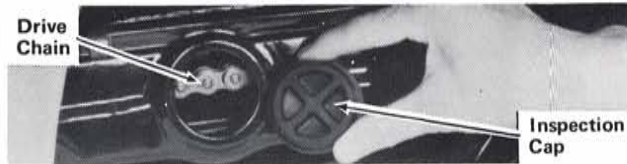

STEP 40—Check drive chain slack and lubrication. If necessary, adjust and lubricate drive chain as described in owner's manual or shop manual.

Slack: 15-25mm (5/8 - 1 in.)

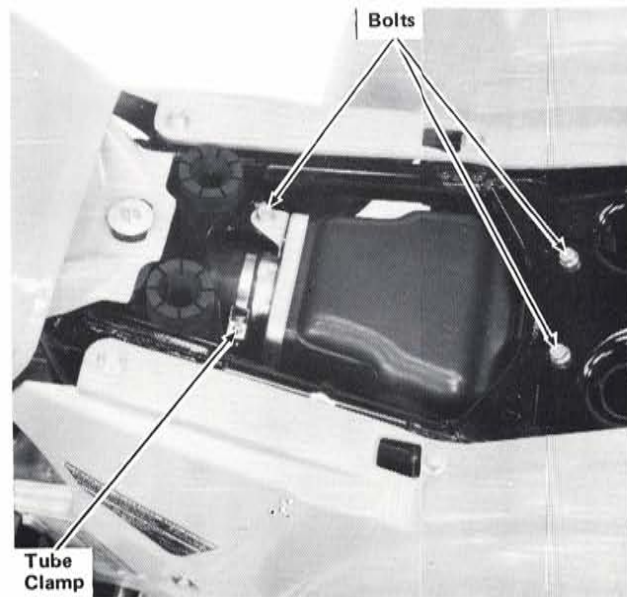
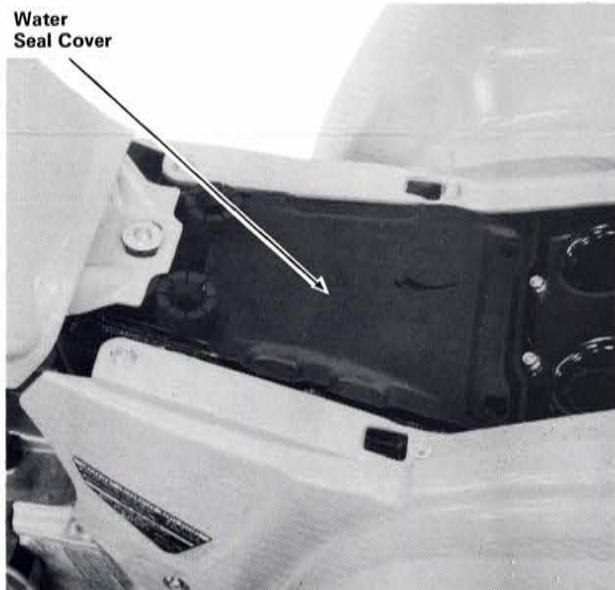

STEP 41—Remove water seal cover by lifting front end up. Remove three bolts attaching air cleaner case and remove air cleaner tube clamp. Remove air cleaner assembly from frame and filter element from its core. Check condition of element. If necessary, clean element as described in owner's manual or shop manual. Reinstall element, air cleaner tube clamp, air cleaner case, and water seal cover.

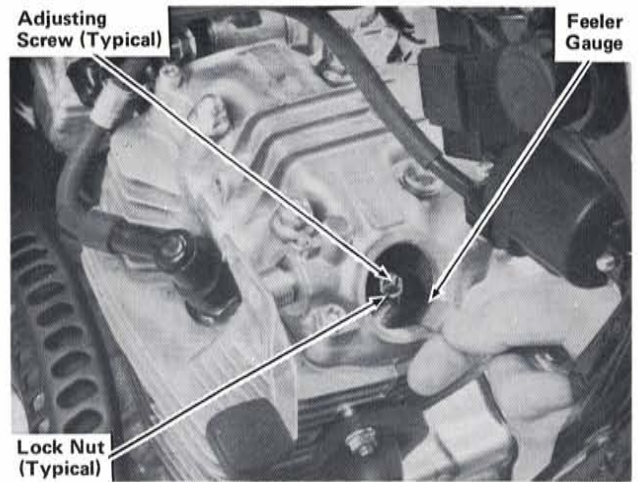

STEP 42—Check valve clearance and adjust if necessary as follows:

NOTE: Valve clearance adjustment must be done while engine is cold (below 35° C; 95° F).

1. Remove timing mark cap and valve adjuster hole caps.
2. Rotate crankshaft using recoil starter and align "T" mark on rotor with index mark on crankcase. Piston must be at T.D.C. (Top Dead Center) of compression stroke.
3. Insert feeler gauge between adjusting screw and valve stem of intake and exhaust valves.
4. If adjustment is necessary, loosen lock nut and turn adjusting screw as required.
5. After adjustment, hold adjusting screw and tighten lock nut.
6. Recheck valve clearance.
7. Reinstall valve adjuster hole caps.

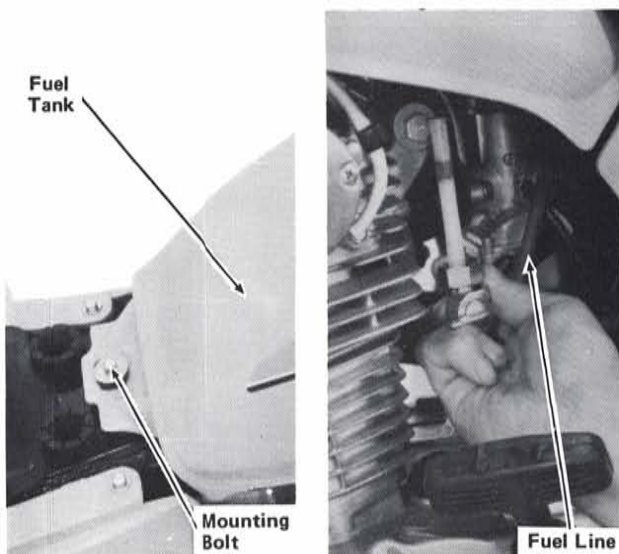

STEP 43—Drain fuel tank as described in shop manual. Remove fuel tank by removing mounting bolt at rear of tank and disconnecting fuel line. Inspect and flush fuel tank. Reinstall fuel tank, connect fuel line, fill tank, turn on fuel tank and check for leaks and flow through fuel filter. Tighten mounting bolt securely.

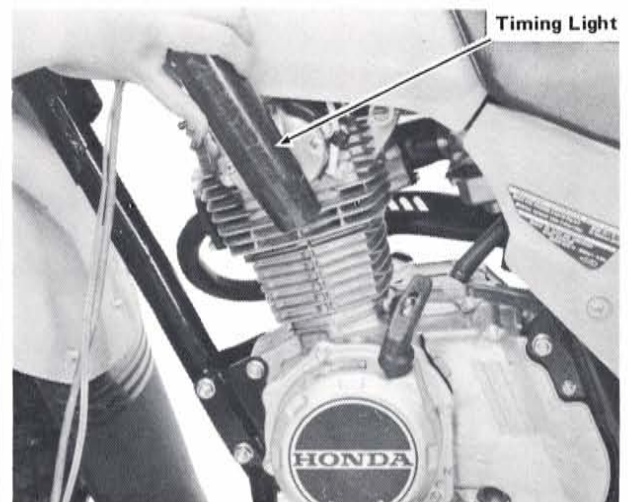

STEP 44—Connect a stroboscopic timing light and check transmission in neutral. Start engine and allow it to idle. Aim timing light at timing mark hole and check that "F" mark is aligned with index mark at idle. Reinstall timing hole cap. Remove timing light.

NOTE: The C.D.I. (Capacitor Discharge Ignition) system is factory preset and cannot be adjusted. If timing is incorrect, check C.D.I. units as described in shop manual.

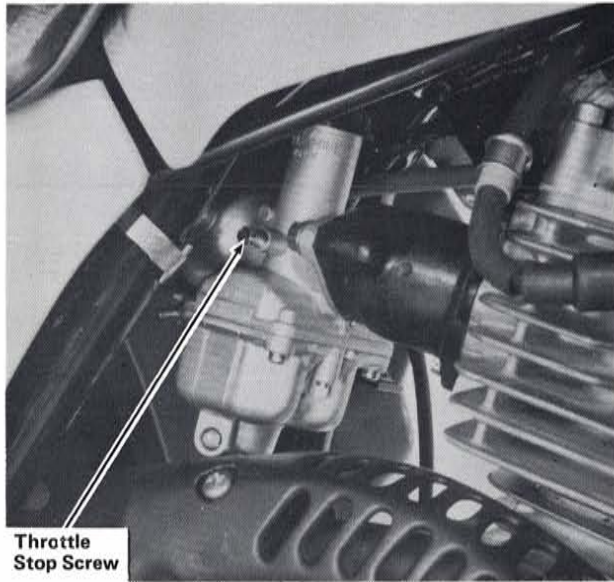
Throttle
Stop Screw

STEP 45—Connect a tachometer and check transmission in neutral. Start engine and allow it to warm up to operating temperature and check idle speed at $1,400 \pm 100$ rpm. If necessary, adjust idle speed using throttle stop screw. Remove tachometer.

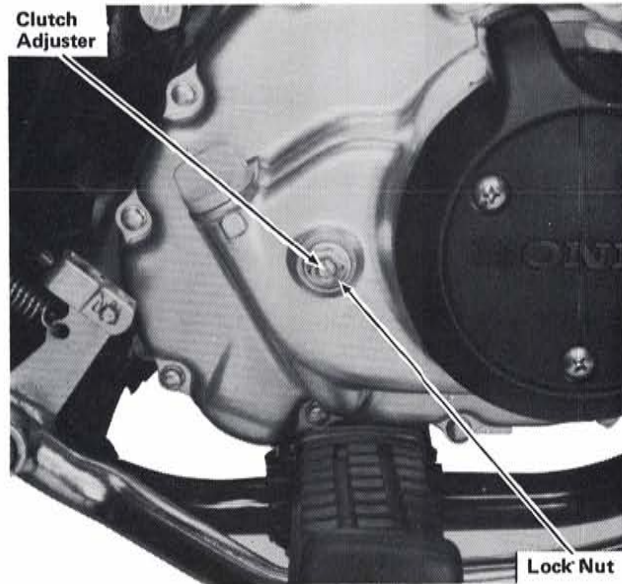

STEP 46—Check clutch operation. If adjustment is necessary, use the following procedure. Loosen lock nut and turn clutch adjuster counter-clockwise until resistance is felt, then turn clutch adjuster $1/8$ turn clockwise and tighten lock nut. Recheck clutch operation.

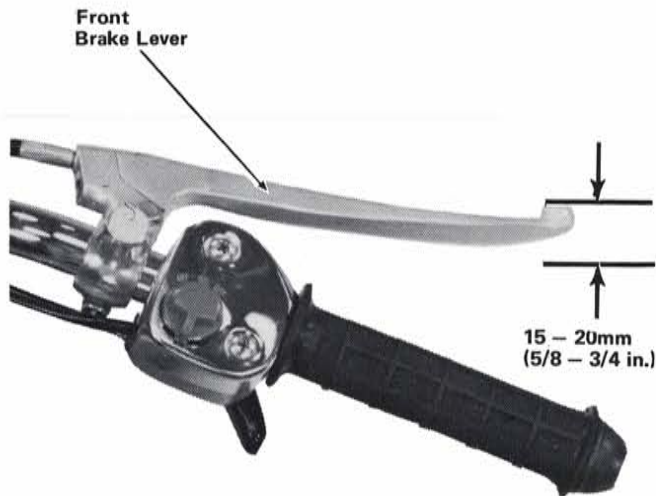
Front
Brake Lever15 - 20mm
(5/8 - 3/4 in.)Adjusting
Nut

STEP 47—Raise front wheel off ground using a support block under engine. Spin front wheel by hand and measure free play of front brake lever before brake starts to engage. Free play, measured at tip of brake lever, should be between 15 and 20mm ($5/8 - 3/4$ in.). If adjustment is necessary, turn adjusting nut on front brake arm. Remove support block under engine.

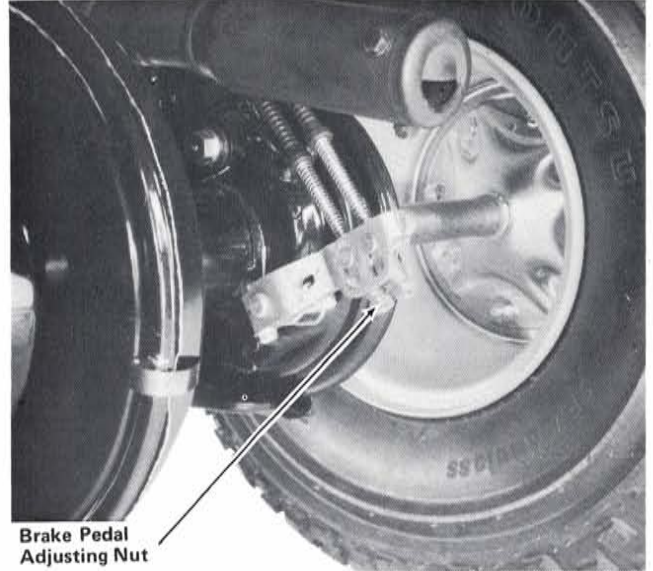
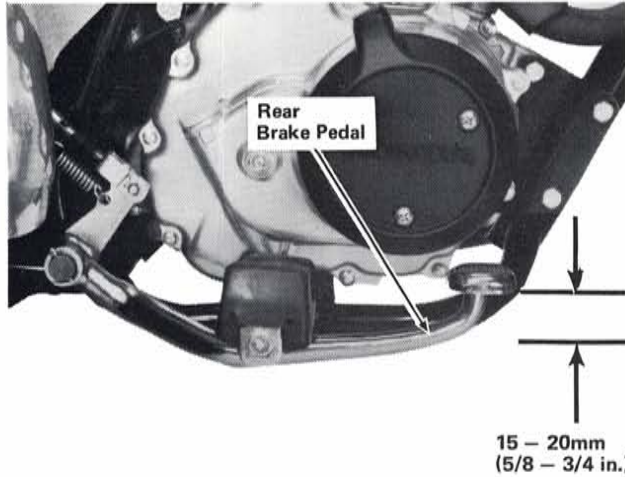

STEP 48—Raise rear wheels off ground using a support block under vehicle. Rotate rear wheels by hand measure free play before brake starts to engage. Free play, measured at tip of brake pedal, should be maintained between 15 and 20mm (5/8 - 3/4 in.). To adjust free play, turn adjusting nut. Turning adjusting nut clockwise will decrease free play.

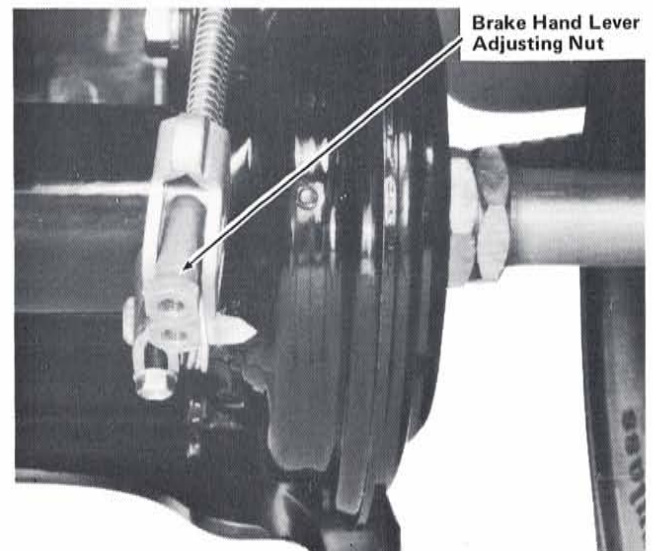
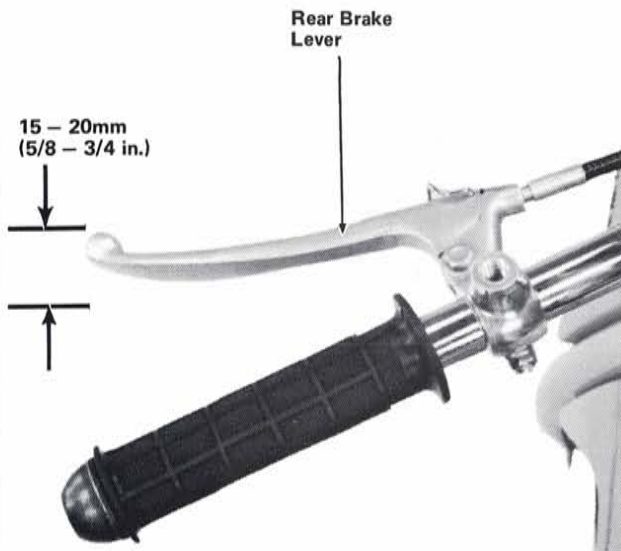

STEP 49—Spin rear wheels by hand and measure free play of rear brake lever before brake starts to engage. Free play, measured at tip of brake lever, should be between 15 and 20mm (5/8 - 3/4 in.). If adjustment is necessary, turn adjusting nut. Turning adjusting nut clockwise will decrease free play. Remove block from under vehicle.

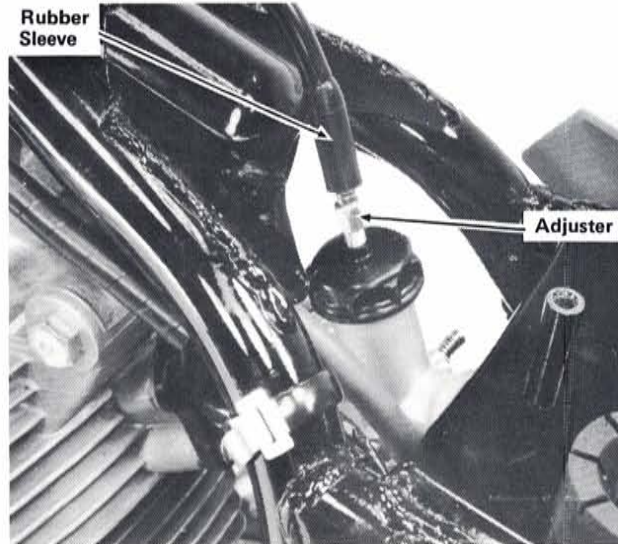
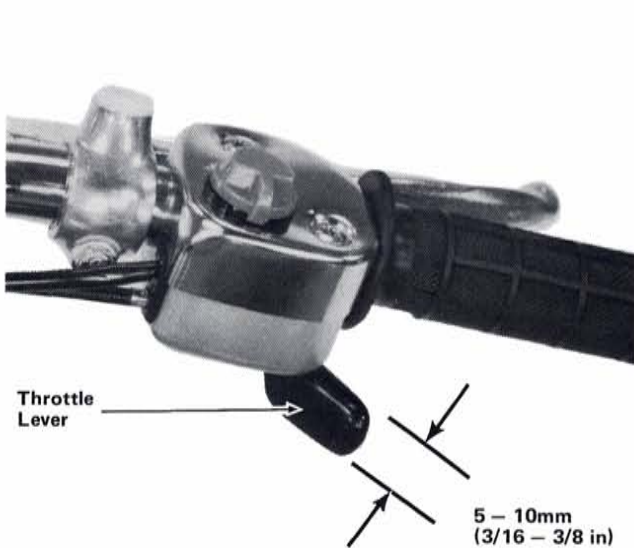

STEP 50—Check throttle cable for condition. Check that throttle lever free play is within 5 — 10mm (3/16 — 3/8 in.) at tip of throttle lever. Check for smooth operation of throttle lever from fully closed to fully open in all steering positions and that throttle lever automatically returns from fully open to fully closed when released. If necessary to adjust free play, slide rubber sleeve back to expose adjuster on top of carburetor. Turn adjuster as required and slide rubber sleeve back over cable adjuster.

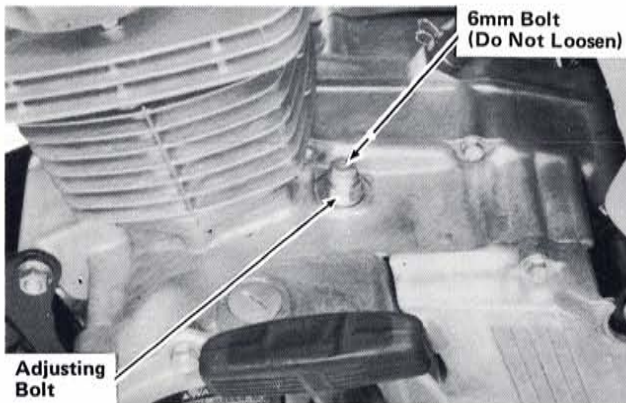

STEP 51—Adjust cam chain as follows:

1. Start engine and allow it to idle.
2. Remove rubber cap from tensioner adjusting bolt.
3. Loosen cam chain tensioner adjusting bolt to allow cam chain to automatically adjust itself to correct tension.

NOTE: Do not loosen the 6mm bolt.

4. Retighten cam chain tensioner adjusting bolt.
5. Reinstall rubber cap over tensioner adjusting bolt.

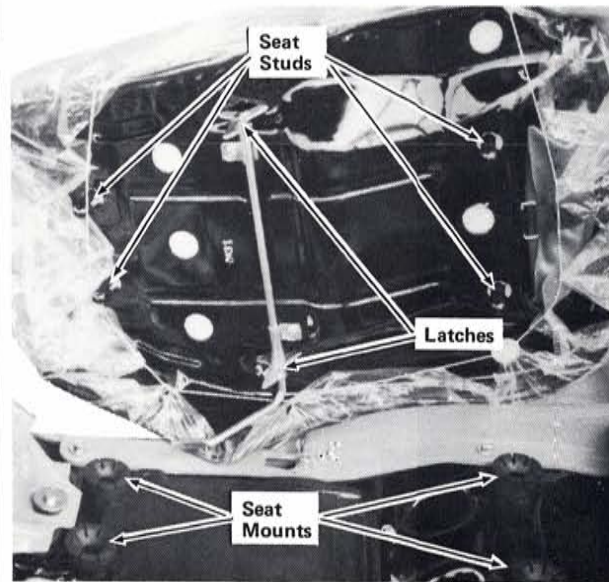

STEP 52—Insert seat studs into holes in seat mounts and engage seat latches.

NOTE: Check that latches are fully engaged.

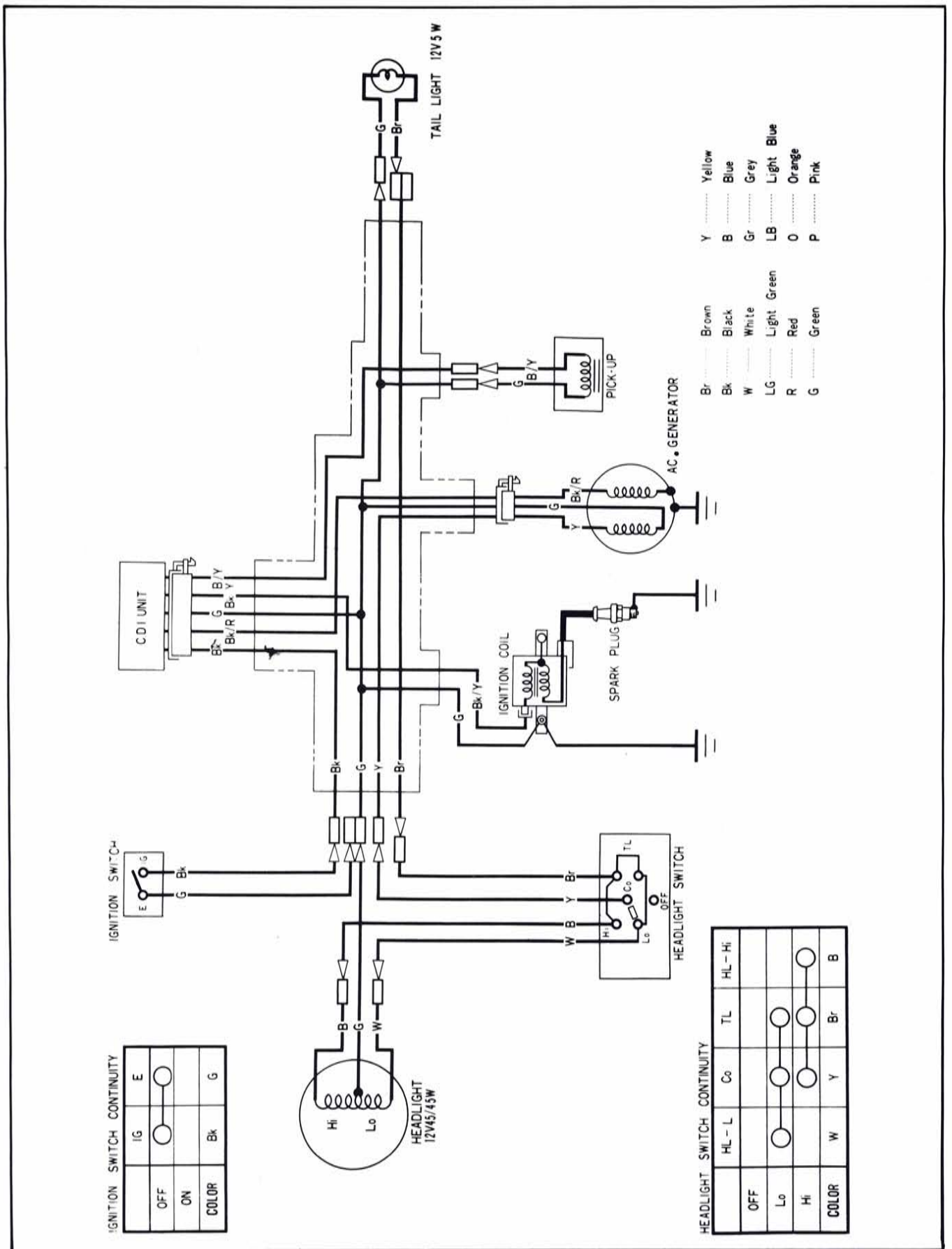

TORQUE TABLE

ITEM	SIZE	TORQUE
Handlebar upper holder bolts	6mm	1.0 kg-m (8 lb-ft)
Front fender bolts	6mm	1.0 kg-m (8 lb-ft)
Front axle nuts	12mm	6.0 kg-m (44 lb-ft)
Rear axle nuts	14mm	7.0 kg-m (51 lb-ft)
Oil drain plug	36mm	1.2 kg-m (9 lb-ft)
Valve adjuster caps	36mm	1.2 kg-m (9 lb-ft)
Cam chain tensioner bolt	16mm	1.8 kg-m (13 lb-ft)
Front fork bolts	10mm	4.4 kg-m (32 lb-ft)

NOTE: Check all items listed on the following Pre-delivery Service Check List. Refer to owner's manual or shop manual for specifications and detailed procedures. Always test ride the unit to make sure that it is functioning properly.

PRE-DELIVERY SERVICE CHECK LIST

- | | |
|--|--|
| <ul style="list-style-type: none"> <input type="checkbox"/> Adjust front and rear brakes, check cable routing and check operation. <input type="checkbox"/> Drain oil from crankcase (if necessary). Refill crankcase with recommended oil. <input type="checkbox"/> Remove and inspect fuel tank, drain and flush. <input type="checkbox"/> Check and clean air filter element. <input type="checkbox"/> Check valve clearance; adjust if necessary. <input type="checkbox"/> Reinstall fuel tank, fill turn on petcock and check for leaks. <input type="checkbox"/> Check ignition timing. <input type="checkbox"/> Adjust idle speed. <input type="checkbox"/> Check throttle lever free play, cable routing, and operation in all steering positions. <input type="checkbox"/> Adjust cam chain tension. <input type="checkbox"/> Adjust and lubricate drive chain. <input type="checkbox"/> Check tire pressure. | <ul style="list-style-type: none"> <input type="checkbox"/> Inspect electrical components for proper operation and adjustment. <ul style="list-style-type: none"> • Headlight: Adjust. • Taillight. • Engine stop switch. <input type="checkbox"/> Check security of all nuts, bolts, and other fasteners. <input type="checkbox"/> Check to ensure all applicable recall and product update campaigns are complied with. <input type="checkbox"/> TEST RIDE: Check performance, handling, and operation: <ul style="list-style-type: none"> • Transmission and clutch: Ease of shifting, clutch operation, etc. • Acceleration: Smoothness, etc. • Cruising: Smoothness, etc. • Handling: Stability and cornering. • Brakes: Smoothness and stopping power. • Idling: Smoothness, throttle response, and return to idle. • Recheck idle speed after 10 minutes of stop and go operation. • Upon completion of test ride, check for fuel and oil leaks. |
|--|--|

LOOSE PARTS LIST

The following is a list of items contained in the parts package carton and loose parts in the crate:

PARTS PACKAGE CONTENTS

DESCRIPTION	H/C	PART NUMBER
Handlebar	---	5310Z-956-0000
Upper holder (2 req'd)	66162	95014-21101
Washer, plain, 6mm (4 req'd)	05907	94101-06000
Bolt, hex head, 6 x 28mm (4 req'd)	17012	90117-065-000
Rear wheel (2 req'd)	---	-----
Washer, 14mm (2 req'd)	70792	42322-943-000
Castle nut, 14mm (req'd)	23402	94011-14000-OS
Pin, cotter, 3.0 x 25mm (4 req'd: 2 for front axle; 2 for rear axle)	05842	94201-30250
Seat	---	-----
Rear fender, L	84298	80150-958-000ZA
Rear fender, R	84294	80100-958-000ZA
Rear mud guard (2 req'd)	84295	80111-958-000
Backing plate, rear, rear fender (2 req'd)	84296	80112-958-000
Backing plate, side, rear fender (2 req'd)	84297	80113-958-000
Bolt, 5 x 18mm (18 req'd)	---	90105-958-000
Nut, flange, 5mm (8 req'd)	61267	94050-05080
Stay, rear fender (2 req'd)	84305	80121-958-000
Carrying handle	84311	81200-958-000
Bolt-washer, 8 x 16mm (6 req'd: 4 for carry pipe; 2 for rear fender stays)	70902	93493-08016
Collar, number bracket (12 req'd), right and left rear fenders	84361	84706-415-000
Bolt-washer, 6 x 16mm (10 req'd), right and left rear fenders	73758	93492-06016-08
Screw-washer, 6 x 16mm (2 req'd)	63474	93892-06016-08
Front fender	84217	61100-958-000ZA
Front mud guard	84221	61861-958-000
Screw, 5 x 12mm (3 req'd), front mud guard	---	90104-958-000
Washer, plain, 5mm (3 req'd)	79597	94103-05800
Washer, plain, 5mm (3 req'd)	05905	94101-05000
Cap nut, 5mm (3 req'd)	84345	94021-05000-OS
Fixing washer (4 req'd), front fender	29937	64348-086-000
Bolt, hex head, 6 x 16mm (4 req'd)	62380	92000-06016-OH
Bolt, hex head 8 x 25mm, front brake panel	26215	92000-08025-OH
Collar, front brake stopper, front brake panel	84226	45101-958-000
Nut, self-locking, 8mm, front brake panel	59948	90115-659-003
Adjusting nut B	25776	95015-42000
Brake rod spring A	27105	95014-73100
Brake arm joint B	40094	95015-32001
Front wheel	---	-----
Front axle	84232	44301-958-000
Front axle collar	23386	44302-918-000
O-ring, 1.9 x 11mm (2 req'd)	79409	91301-671-671
Front axle side collar	84233	44312-958-000
Axle nut, 12mm (2 req'd)	24845	90305-051-000
Tool box	---	80200-958-000
Tool set	84328	89010-958-000
Battery band A	33860	95012-11000
Owner's manual	84329	3195800

(

(

(

(

(

(

(

)

)

)

)

)

)

)

READ THIS READ THIS READ THIS

HONDA

MODIFICATIONS WHICH YOU HAVE MADE, OR SHOULD MAKE IN THE FUTURE, TO ANY HONDA MOTORCYCLE, SHALL BE DEEMED BY OUR COMPANY TO HAVE BEEN PERFORMED AT YOUR SOLE RISK AND RESPONSIBILITY, AND WITHOUT OUR COMPANY'S OR THE MANUFACTURER'S APPROVAL OR CONSENT, IMPLIED OR EXPRESSED. WE FURTHER DISCLAIM ANY AND ALL LIABILITY, OBLIGATION, OR RESPONSIBILITY FOR ANY DEFECTS OF MODIFIED PARTS OR OF THE MODIFIED MOTORCYCLE, AND FOR ANY CLAIMS, DEMANDS, OR CAUSES OF ACTION FOR DAMAGE TO PROPERTY OR FOR PERSONAL INJURIES RESULTING FROM THE MODIFICATION OF SAID HONDA MOTORCYCLE.

READ THIS READ THIS READ THIS

READ THIS READ THIS READ THIS