

# Set-up Instructions

# 1981, 1982 Models ATC185S



AMERICAN HONDA MOTOR CO., INC.  
100 WEST ALONDRA BOULEVARD, GARDENA, CALIFORNIA 90247

## WARNING

## WARNING

## WARNING

## WARNING

SET-UP AND PRE-DELIVERY SERVICE MUST BE PERFORMED BY AN AUTHORIZED HONDA MOTORCYCLE DEALER. Proper set-up and pre-delivery service is essential to rider safety and reliability of the motorcycle. When a customer takes delivery of his brand new motorcycle, he expects it to be in excellent running condition. There are few things that will cause greater customer dissatisfaction than poor preparation of a new motorcycle. An error or oversight made by the mechanic assembling and servicing a new unit can easily result in faulty operation, damage to the machine, or even injury to the rider.

*THIS ISSUE OF THE ATC185S SET-UP INSTRUCTIONS REPLACES THE 1980 AND 1981 MODEL ATC185(S) SET-UP INSTRUCTIONS DATED 9/80. REMOVE AND DESTROY SUPERSEDED SET-UP INSTRUCTIONS.*

1982 MODEL SHOWN; 1981 MODEL SIMILAR



### NOTES:

- All steps apply to both the 1981 and 1982 models unless otherwise noted.
- Right and left are determined from the rider's view.

Date of Issue: 7/81

# SET-UP INSTRUCTION REVISED PAGES

**Pages Affected**

1 through 24

**Orig. Issue Date**

7/81

**Rev. Date**

Original

**Remove and destroy superseded pages.**

Pay special attention to warnings, cautions, and notes.

**WARNING** means hazards or unsafe practices which could cause severe personal injury or death.

**CAUTION:** means hazards or unsafe practices which could cause minor personal injury or product or property damage.

*NOTE:* gives helpful information.



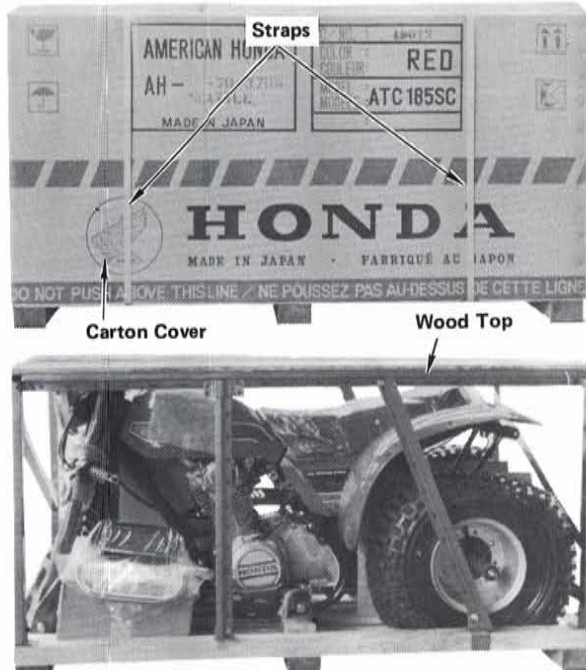

**STEP 1**—Cut straps and remove carton cover by lifting it up. Remove crate wood top.

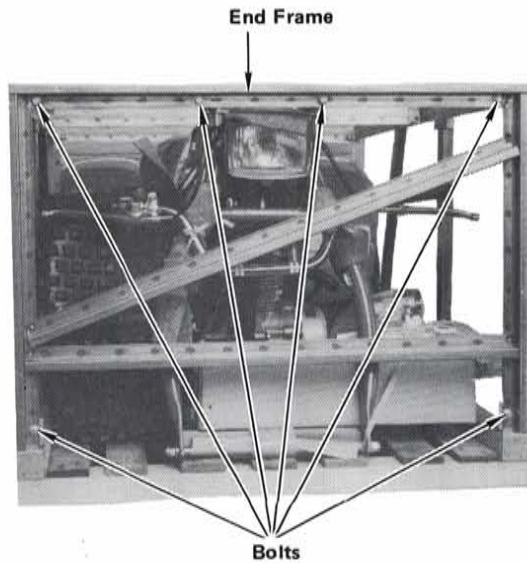

**STEP 2**—Remove six bolts attaching crate front end frame to steel crate top, crate base, and upper fork bridge brackets. Discard bolts and end frame.

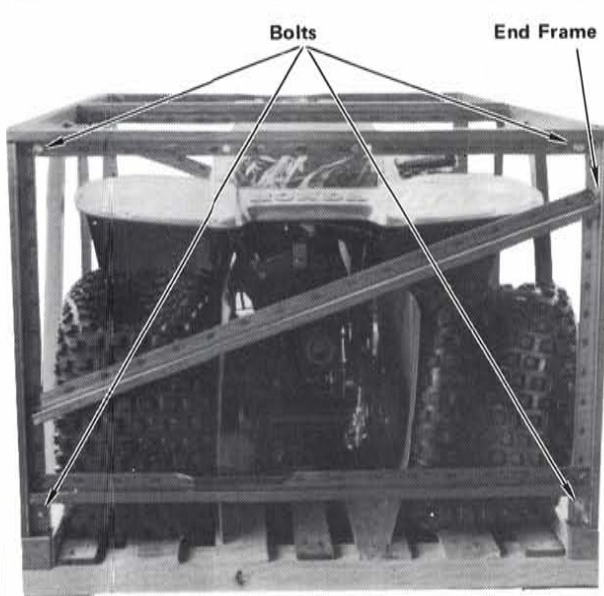

**STEP 3**—Remove four bolts attaching crate rear end frame to steel crate top and crate base. Discard bolts and end frame.

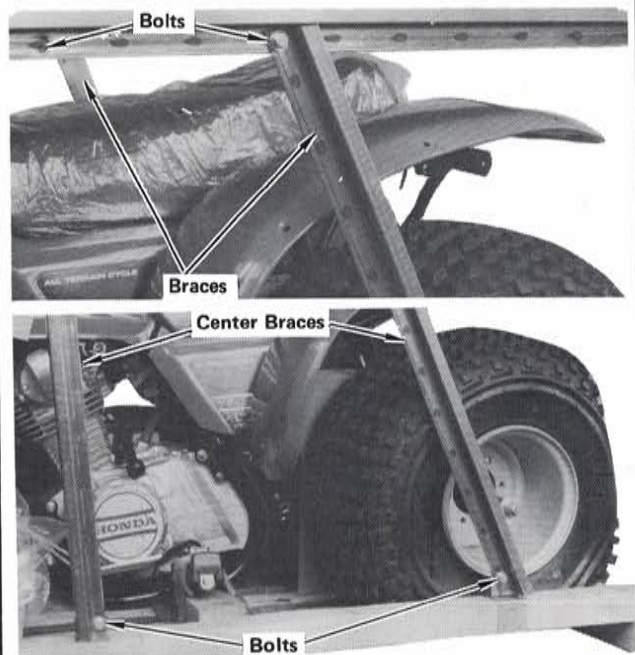

**STEP 4**—Remove bolts attaching rear center brace to steel crate top. Remove crate top and discard. Discard bolts. Remove bolts attaching center braces to crate base. Discard bolts and braces.

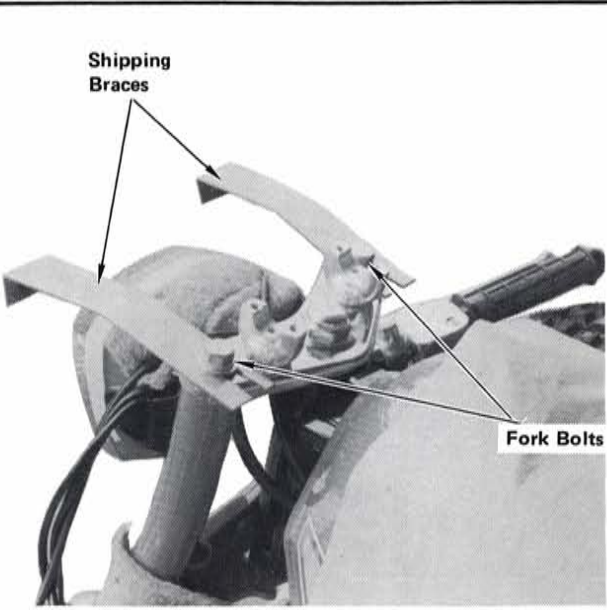

Shipping Braces

Fork Bolts

**STEP 5**—Loosen fork bolts and remove shipping braces and retighten fork bolts to specified torque.

**Torque specification:**  
6.0 kg-m (44 lb-ft)

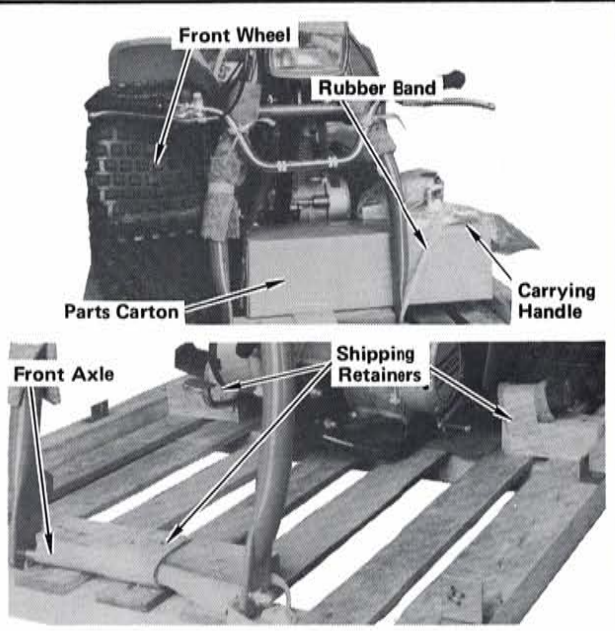

Front Wheel

Rubber Band

Parts Carton

Carrying Handle

Front Axle

Shipping Retainers

**STEP 6**—Remove rubber band and remove front wheel, parts carton, and carrying handle. Remove nails and remove lower shipping retainers holding front axle and foot pegs to crate base.



Rear Fender

Latch Handle

**STEP 7**—Remove rear fender by moving latch handle sideways.

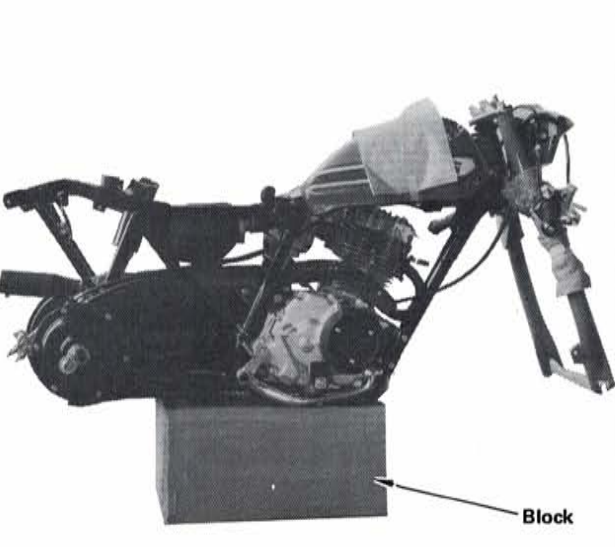

Block

**STEP 8**—Carefully remove vehicle from crate base and support on padded block centered under engine as shown.

**CAUTION:** The vehicle can easily be tipped over until it is resting on front and rear wheels.



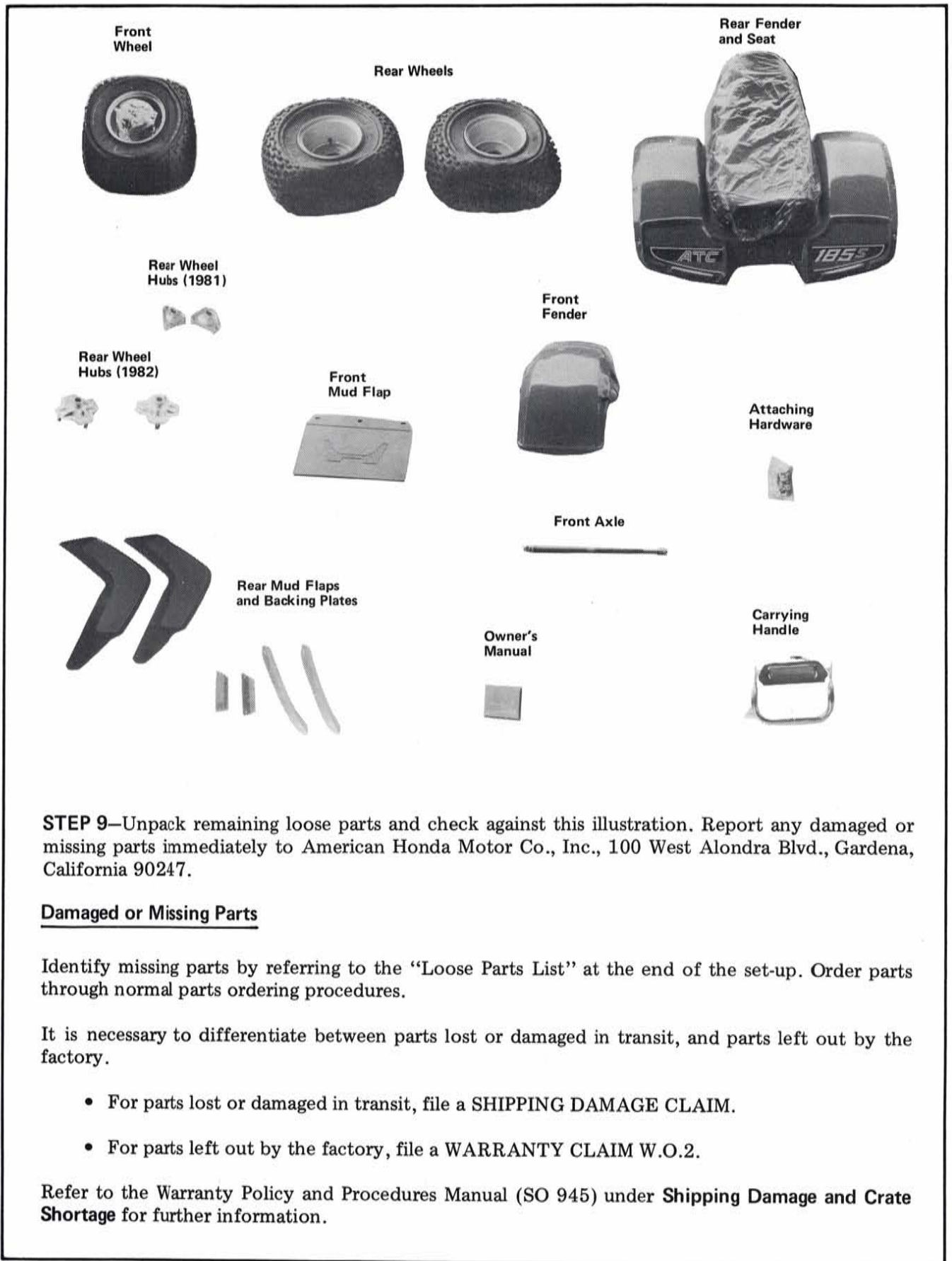

**STEP 9**—Unpack remaining loose parts and check against this illustration. Report any damaged or missing parts immediately to American Honda Motor Co., Inc., 100 West Alondra Blvd., Gardena, California 90247.

**Damaged or Missing Parts**

Identify missing parts by referring to the “Loose Parts List” at the end of the set-up. Order parts through normal parts ordering procedures.

It is necessary to differentiate between parts lost or damaged in transit, and parts left out by the factory.

- For parts lost or damaged in transit, file a SHIPPING DAMAGE CLAIM.
- For parts left out by the factory, file a WARRANTY CLAIM W.O.2.

Refer to the Warranty Policy and Procedures Manual (SO 945) under **Shipping Damage and Crate Shortage** for further information.

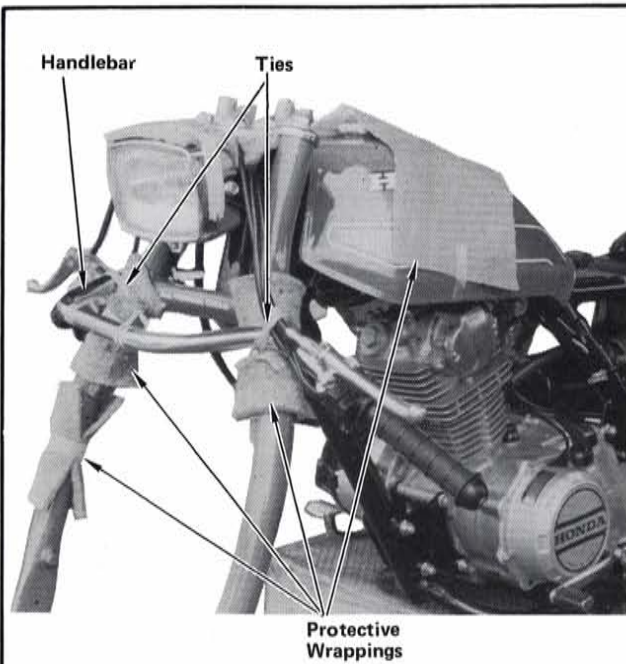

**STEP 10**—Remove ties holding handlebar to front forks. Remove all protective wrappings from front forks, headlight, and fuel tank.

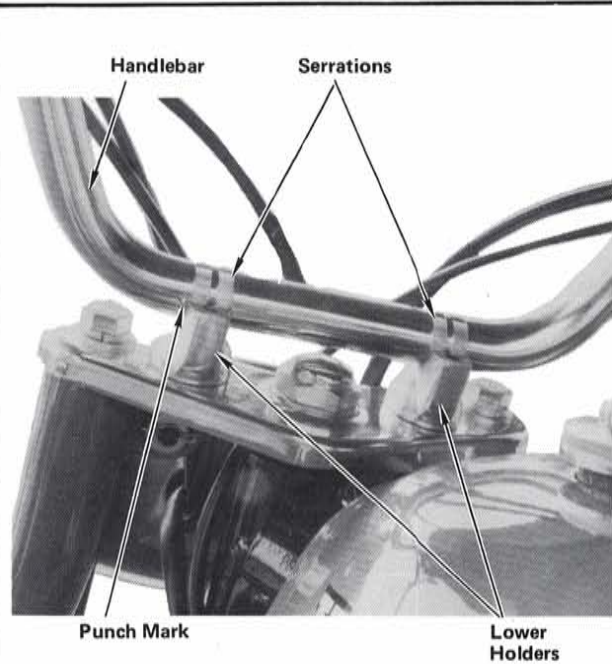

**STEP 11**—Position handlebar on lower holders with serrations aligned with holders and punch mark on handlebar aligned with top of holders.

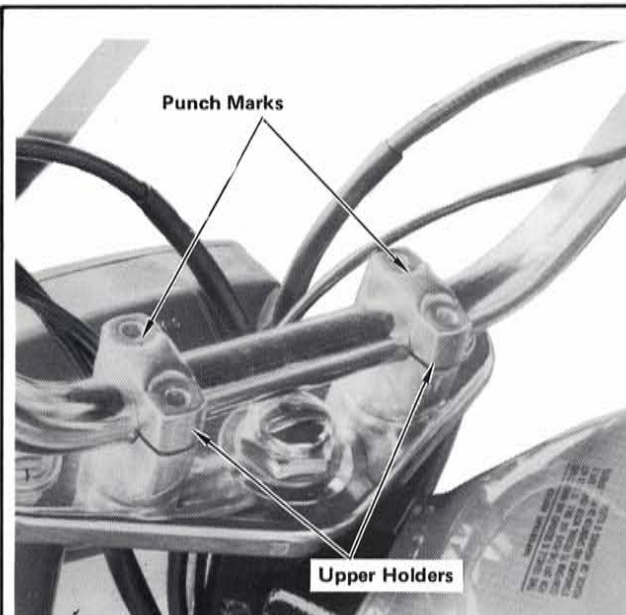

**STEP 12**—Position upper holders on handlebar with punch marks on holders forward.

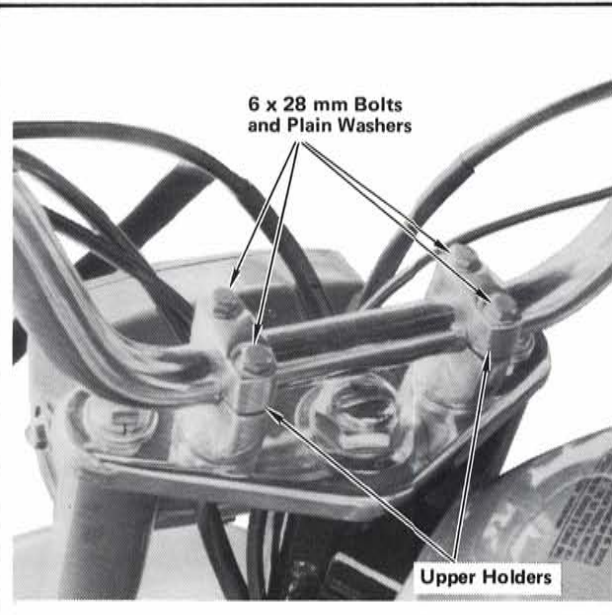

**STEP 13**—Install upper holders using four 6 x 28 mm bolts and plain washers. Tighten forward bolts to specified torque first, then tighten rear bolts to same torque.

**Torque specification:**  
1.0 kg-m (8 lb-ft)



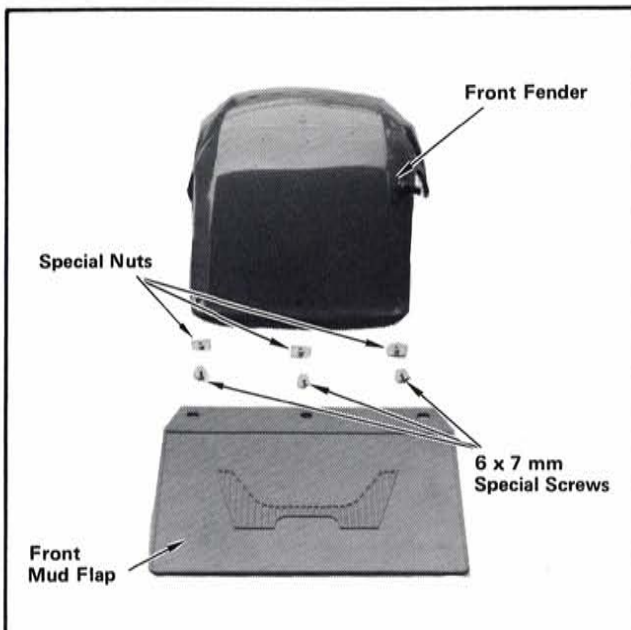

**STEP 14**—Check front fender mud flap and attaching hardware.

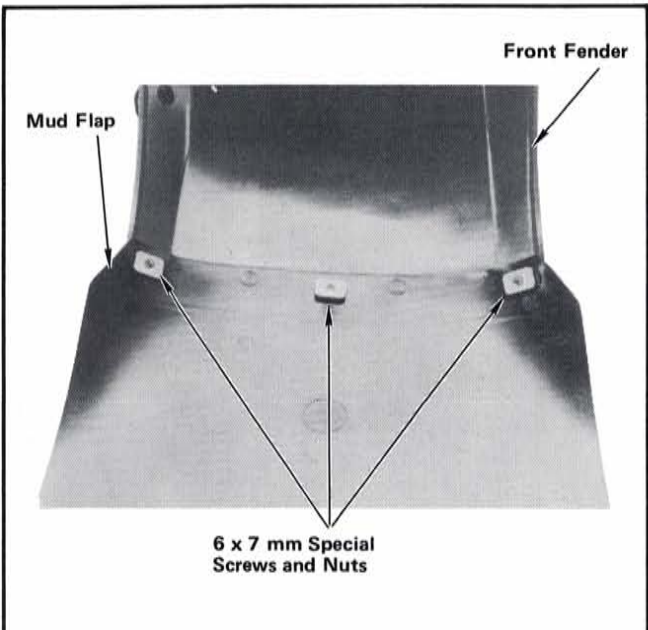

**STEP 15**—Position mud flap under front fender as shown and install using three 6 x 7 mm special screws inserted down through fender, and special nuts under fender as shown. Tighten screws securely.

*NOTE: Note position of special nuts.*

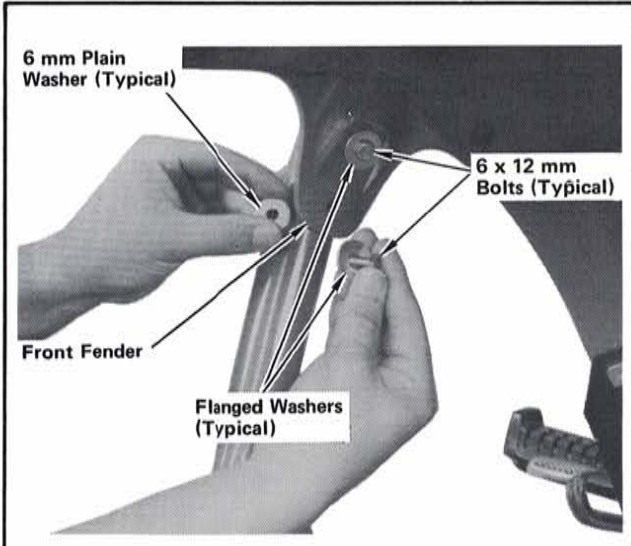

**STEP 16**—Position front fender between fork legs with mud flap towards the rear, and install using four 6 x 12 mm bolts, flanged washers, and two plain washers as shown. Plain washers go between fork leg and fender at lower bolt holes. Tighten bolts to specified torque.

**Torque specification:**  
1.0 kg-m (8 lb-ft)

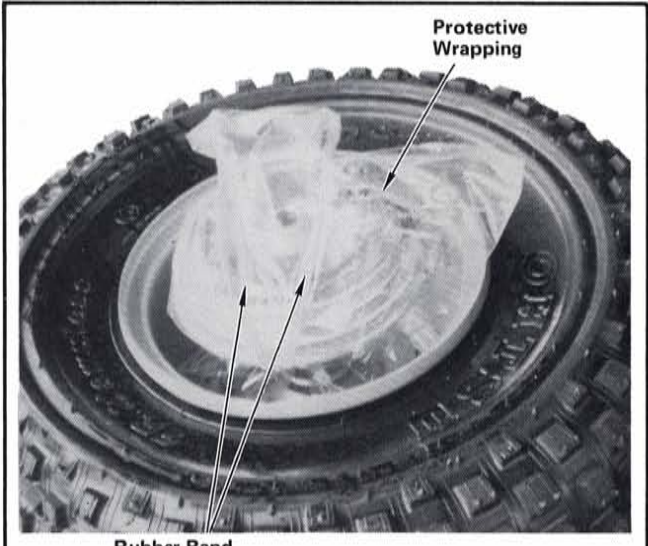

**STEP 17**—Remove rubber band and remove protective wrapping from front brake. Remove front brake and check that brake linings and brake drum are clean. Check that grease seal is full of grease. If necessary, wipe brake drum with a clean cloth.

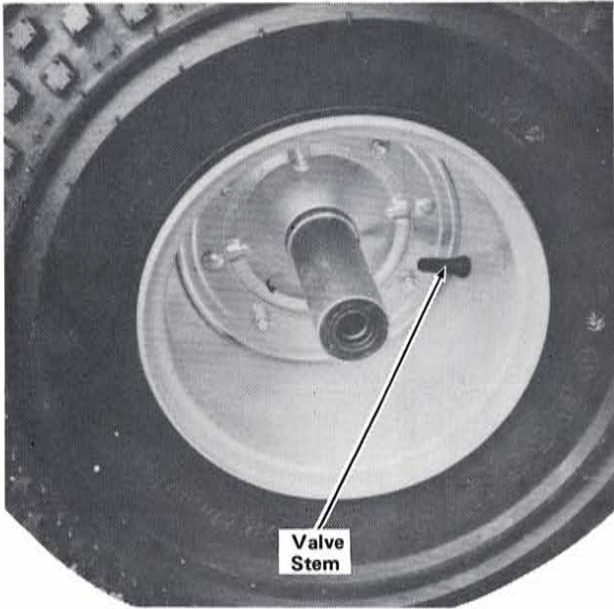

**STEP 18**—Inflate and check tire pressure of all three tires.

Tire Pressure: 2.2 psi.

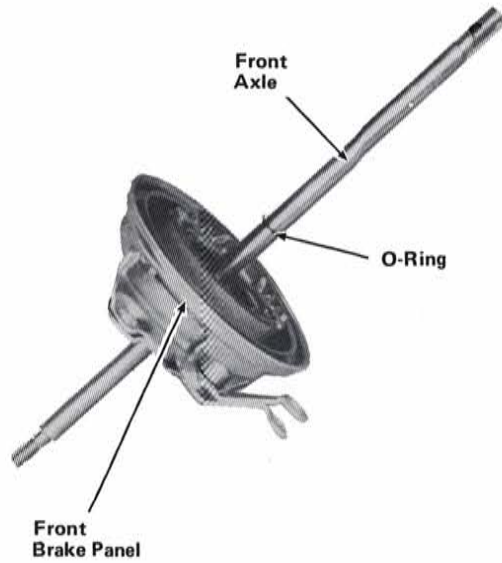

**STEP 19**—Slide front axle through front brake panel and slip an o-ring over axle from brake shoe side as shown.

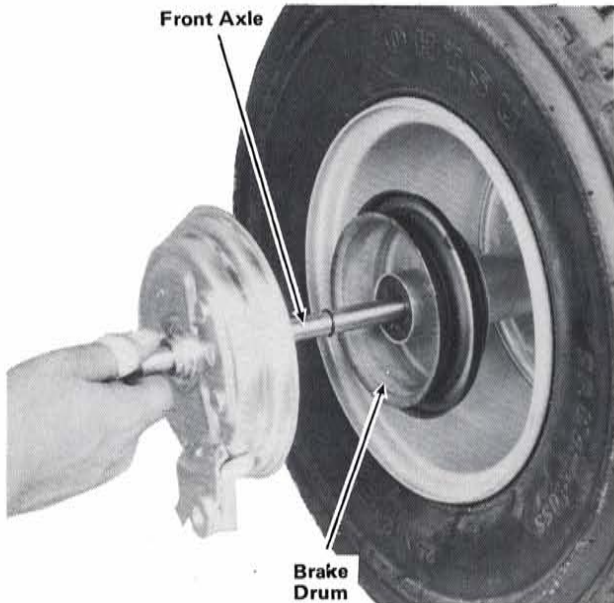

**STEP 20**—Insert front axle through front wheel hub from brake drum side as shown.

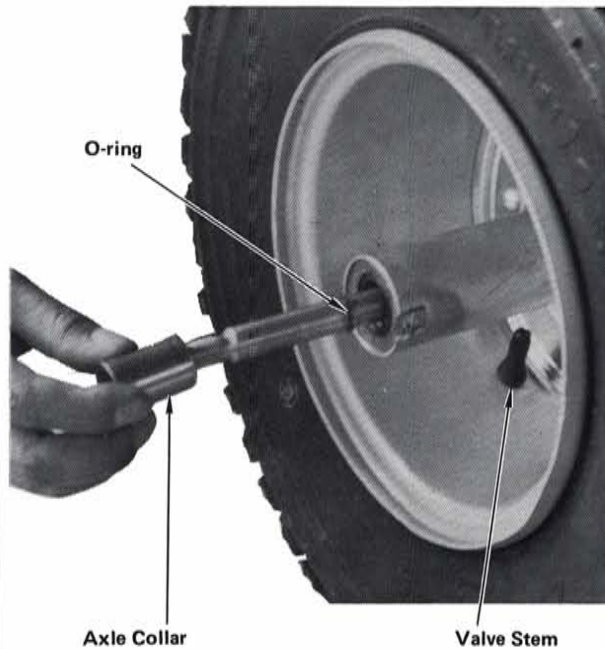

**STEP 21**—Slip an o-ring and axle collar over front axle from valve stem side as shown.



1981 MODEL ONLY

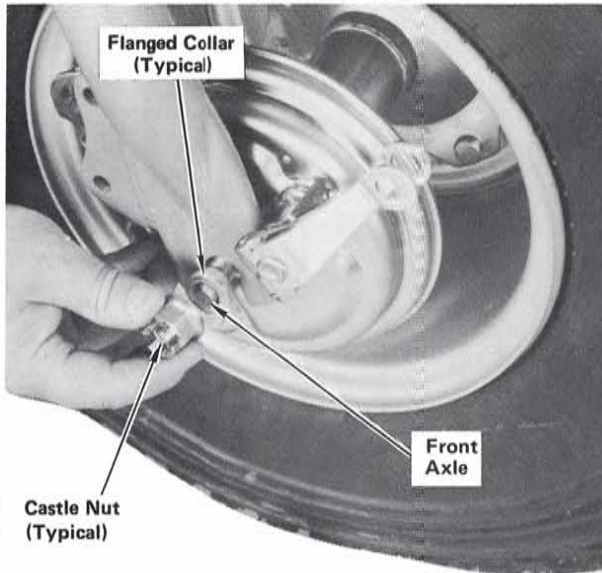

**STEP 22**—Position front wheel between fork legs, with brake panel on right. Install a flanged collar and a castle nut on each end of front axle. Do not tighten nuts at this time.

1981 MODEL ONLY

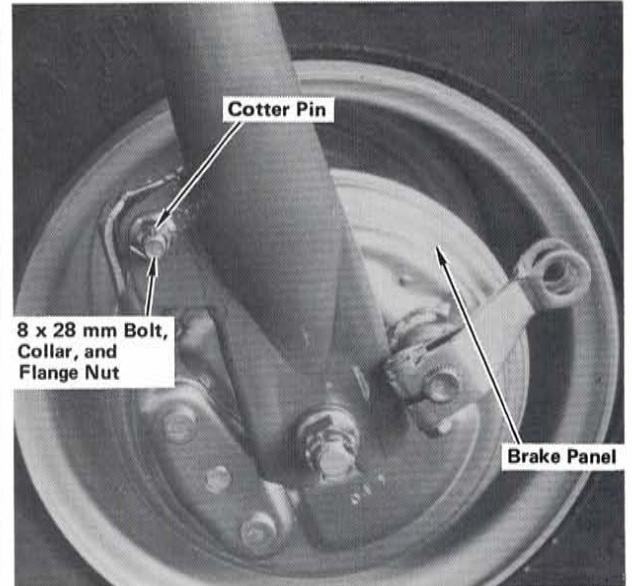

**STEP 23**—Attach front brake panel to right fork leg using an 8 mm bolt, collar, and flange nut, with collar between brake panel and fork leg. Tighten securely. Nut is on outside. Insert a cotter pin through hole in bolt and spread ends of cotter pin as shown.

1982 MODEL ONLY

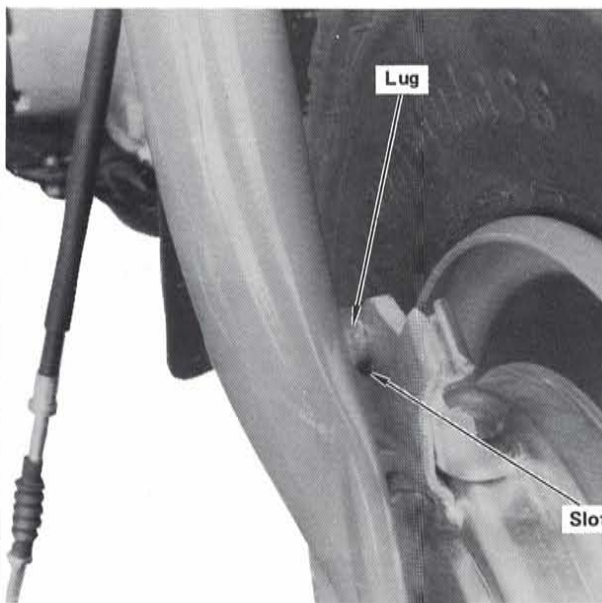

**STEP 24**—Position front wheel between front fork legs, aligning lug on right fork leg with slot in stopper plate on brake panel.

1982 MODEL ONLY

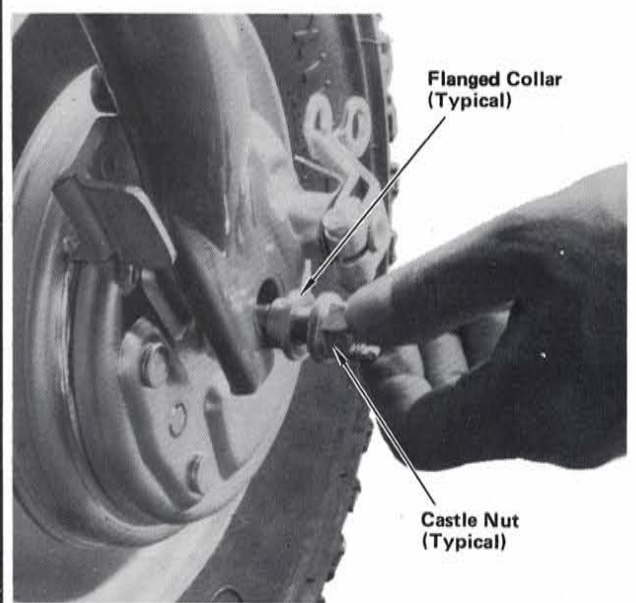

**STEP 25**—Install a flanged collar and a castle nut on each end of front axle. Do not tighten nuts at this time.



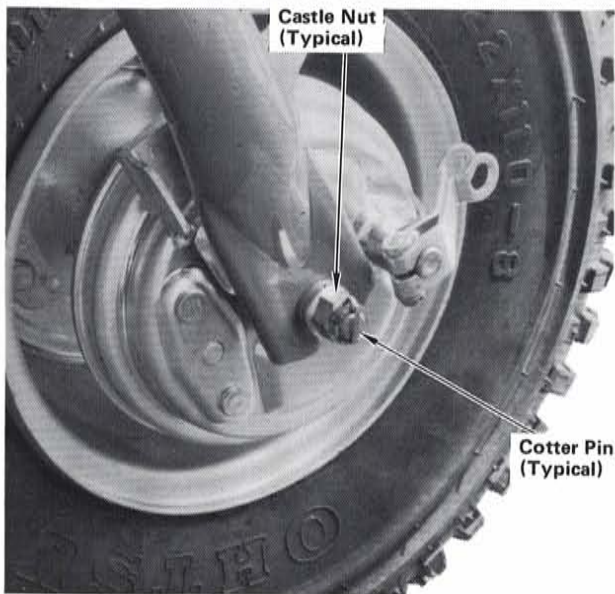

**STEP 26**—Tighten both axle nuts equally to specified torque. Install a cotter pin in each and spread ends of cotter pins as shown.

**Torque specification:**  
6.0 kg-m (44 lb-ft)

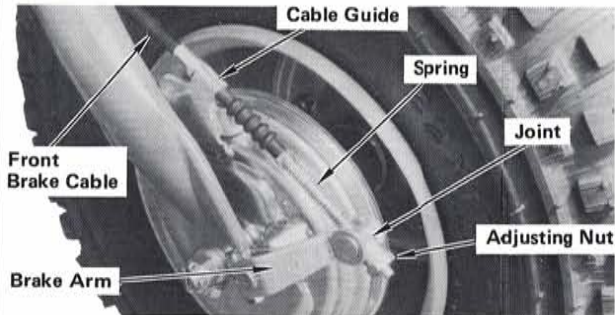
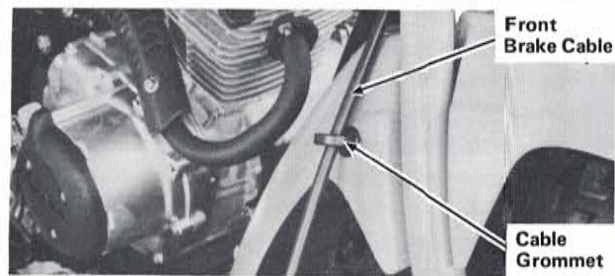

**STEP 27**—Route front brake cable down through cable grommet on front fender, and through cable guide on brake panel. Slip brake return spring over end of brake cable and connect cable to front brake arm using a brake arm joint and cable adjusting nut. Adjust front brake as described in Step 47.

**1981 MODEL ONLY**

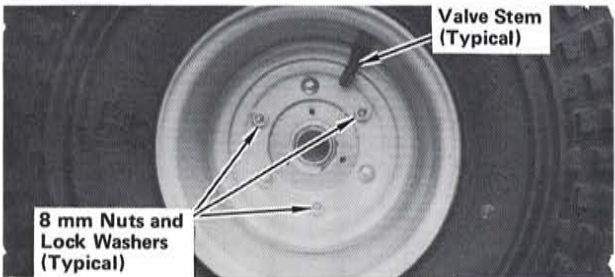
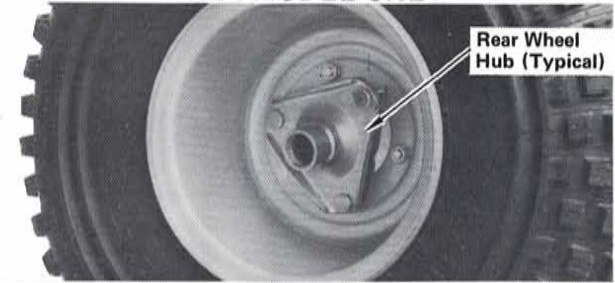

**STEP 28**—Insert studs of rear hubs through rear wheels from side opposite valve stem. Install each hub using three 8 mm lock washers and nuts on side of wheel having valve stem. Tighten nuts to specified torque.

**Torque specification:**  
2.2 kg-m (16 lb-ft)

**1981 MODEL ONLY**

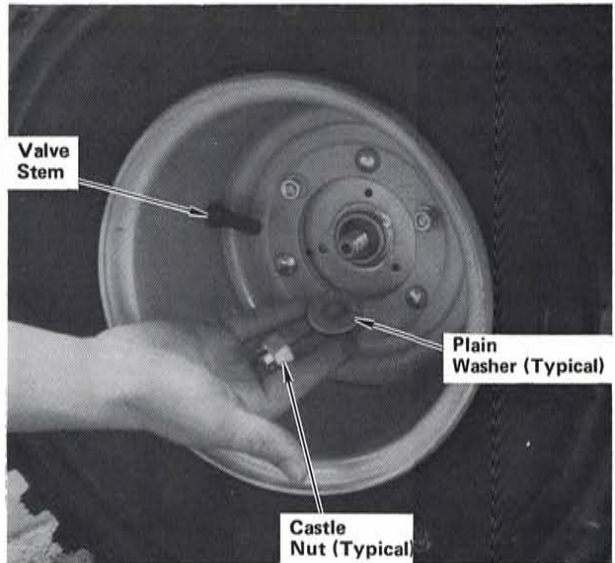

**STEP 29**—Grease rear axle splines and install rear wheels, with valve stems to the outside, using a plain washer and a castle nut for each.



1981 MODEL ONLY

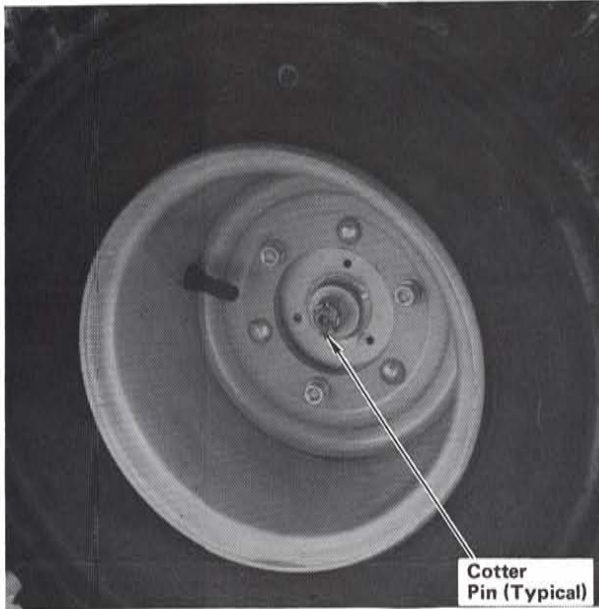

Cotter Pin (Typical)

**STEP 30**—Tighten both castle nuts to specified torque and install a cotter pin in each. Spread ends of cotter pins as shown.

**Torque specification:**  
7.0 kg-m (51 lb-ft)

1982 MODEL ONLY

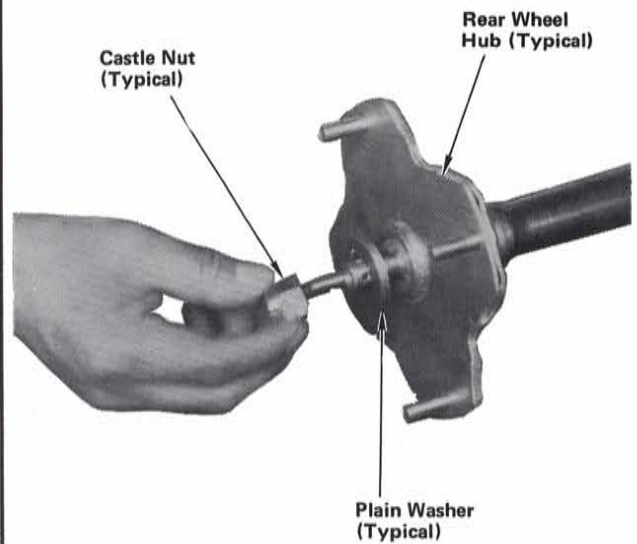

Castle Nut (Typical)

Rear Wheel Hub (Typical)

Plain Washer (Typical)

**STEP 31**—Grease rear axle splines and install rear wheel hubs as shown using a plain washer and a castle nut for each.

1982 MODEL ONLY

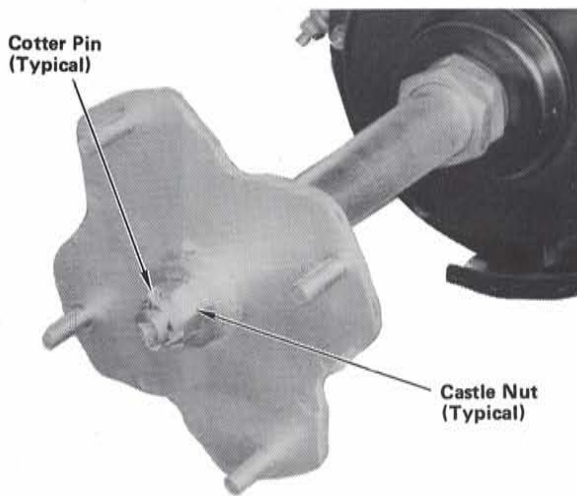

Cotter Pin (Typical)

Castle Nut (Typical)

**STEP 32**—Tighten both castle nuts to specified torque and install a cotter pin in each. Spread ends of cotter pins as shown.

**Torque specification:**  
7.0 kg-m (51 lb-ft)

1982 MODEL ONLY

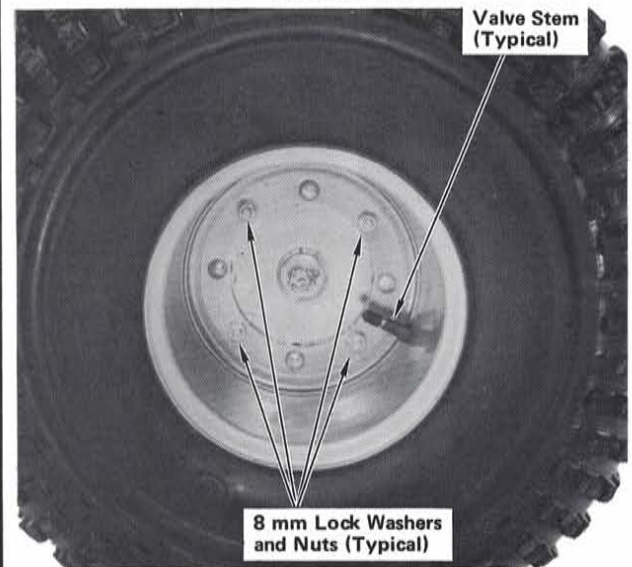

Valve Stem (Typical)

8 mm Lock Washers and Nuts (Typical)

**STEP 33**—Insert studs of rear wheel hubs through holes in rear wheels from side opposite the valve stem. Install each rear wheel using four 8 mm lock washers and nuts as shown. Tighten nuts to specified torque.

**Torque specification:**  
2.2 kg-m (16 lb-ft)

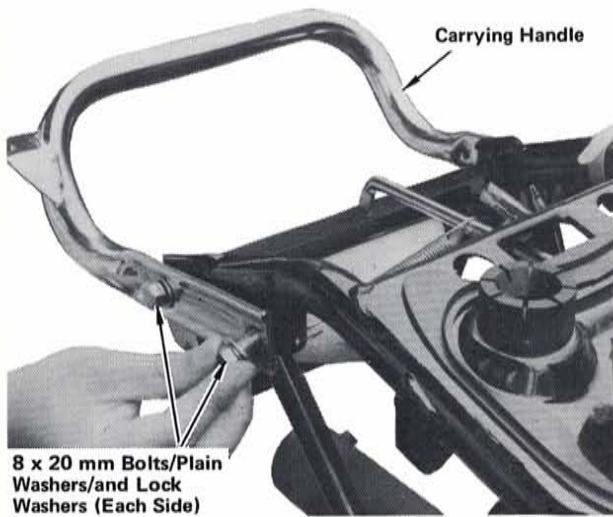

**STEP 34**—Position ends of carrying handle over holes in frame as shown and install using two 8 x 20 mm bolts/plain washers/lock washers for each side. Tighten bolts to specified torque.

**Torque specification:**  
2.2 kg-m (16 lb-ft)

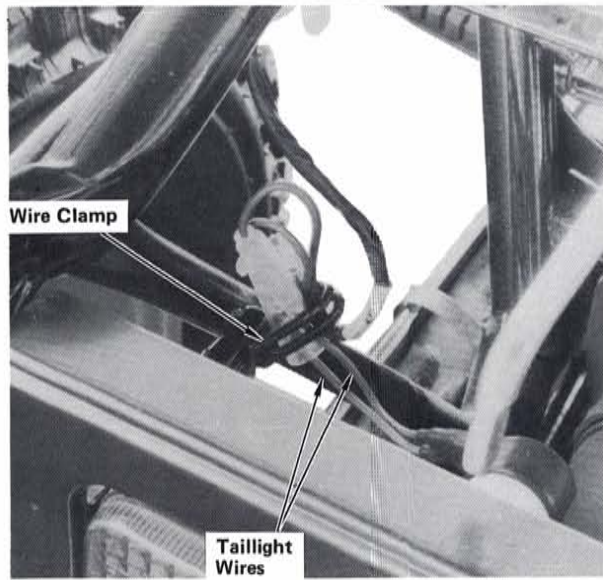

**STEP 35**—Connect taillight wires to wire harness color-to-color. Secure wires and connectors to frame using the wire clamp as shown.

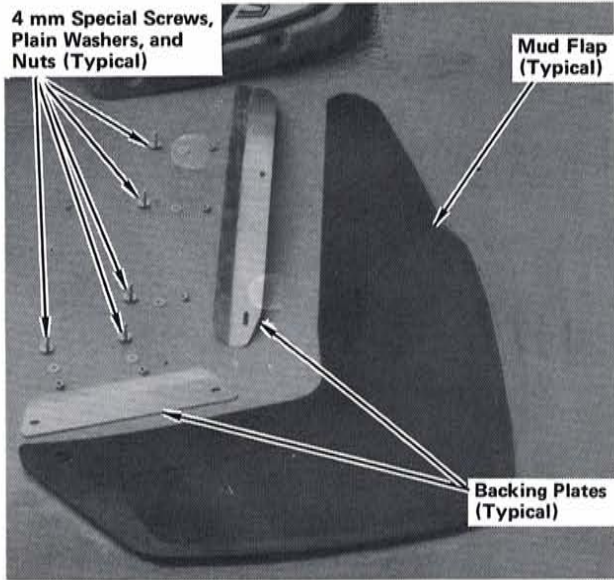

**STEP 36**—Check rear fenders, mud flaps, and attaching hardware.

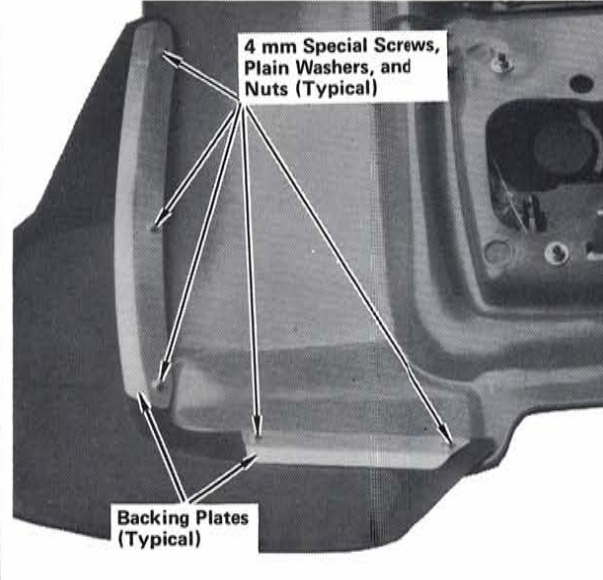

**STEP 37**—Position rear mud flap under rear fender and install using five 4 mm special screws inserted down through fender, and two backing plates and five nuts and plain washers under fender as shown. Repeat for other fender. Tighten all screws securely.



**1981 MODEL ONLY**

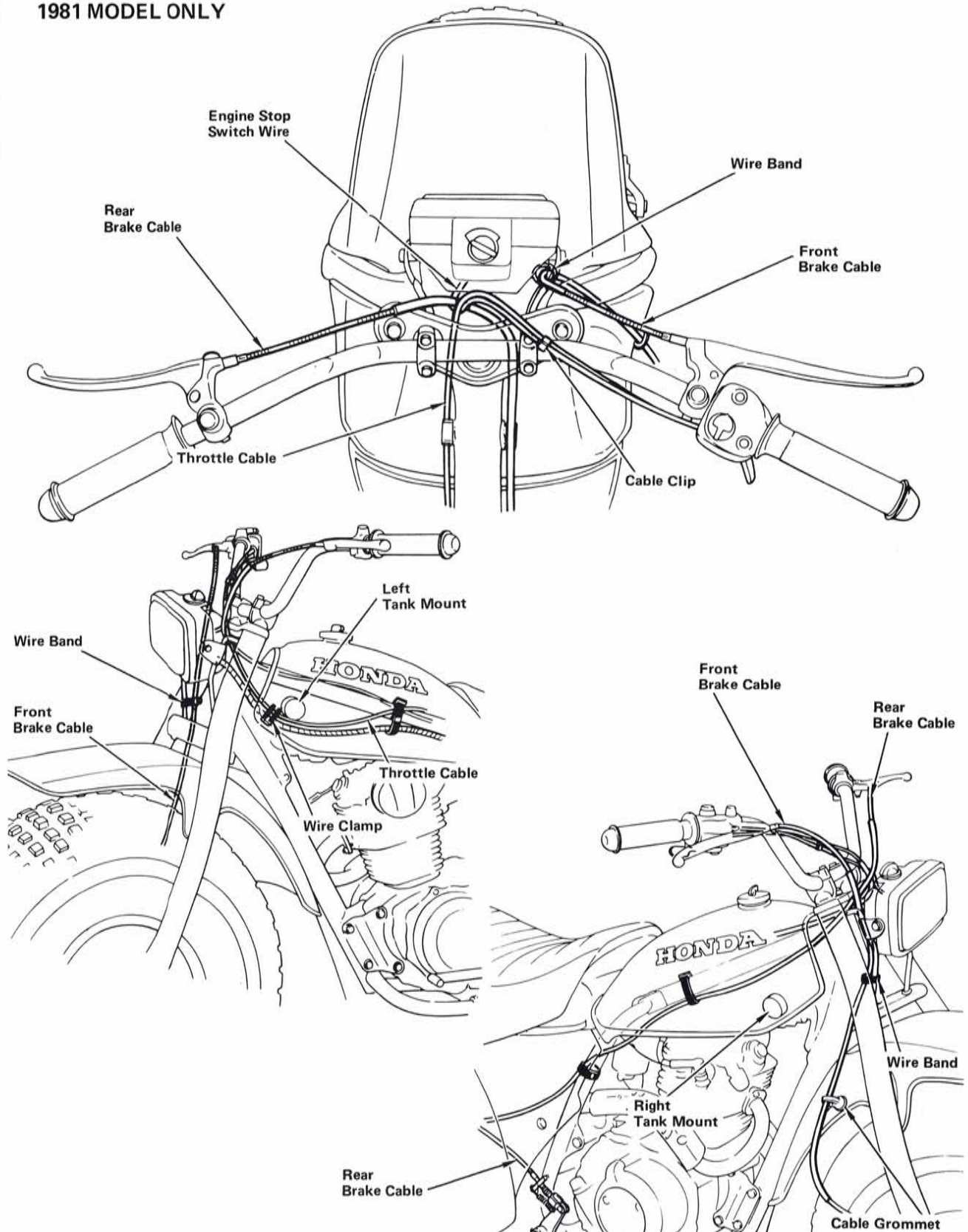

**STEP 38**—Check routing of front and rear brake cables, throttle cable, and engine stop switch wire as shown.

1982 MODEL ONLY

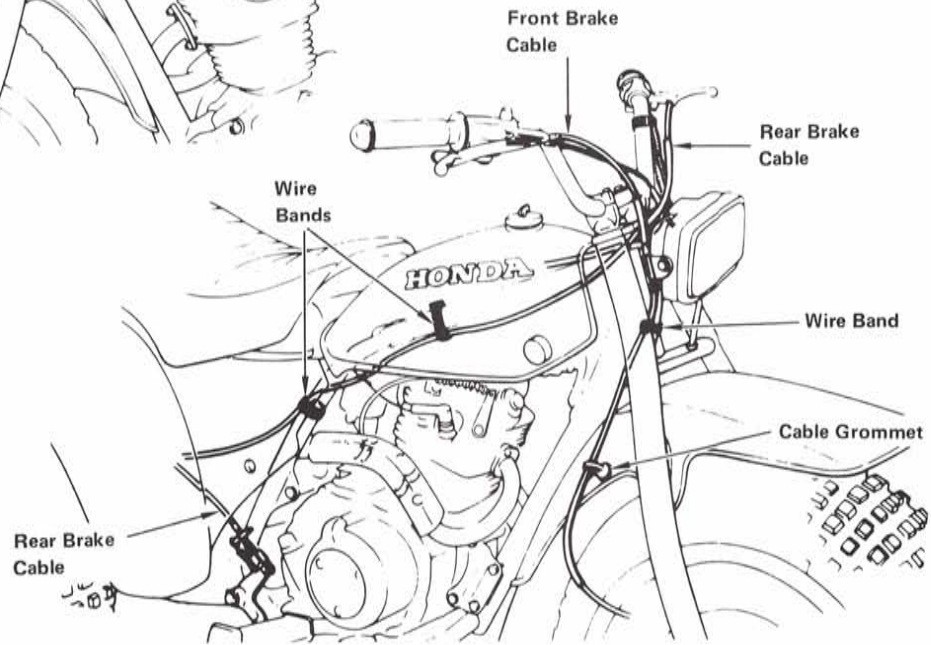
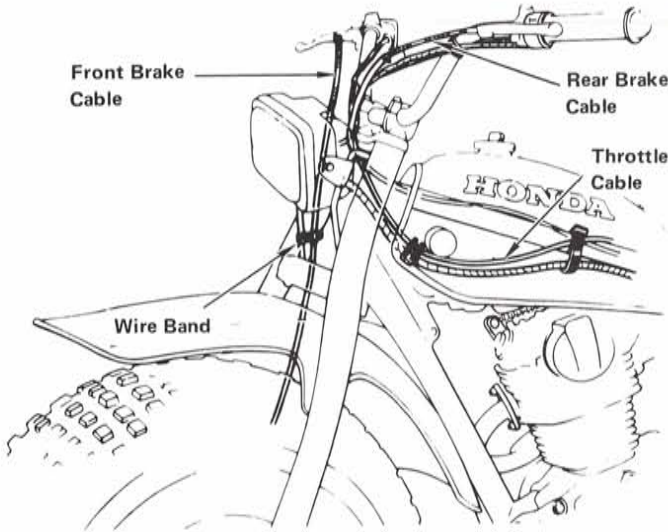
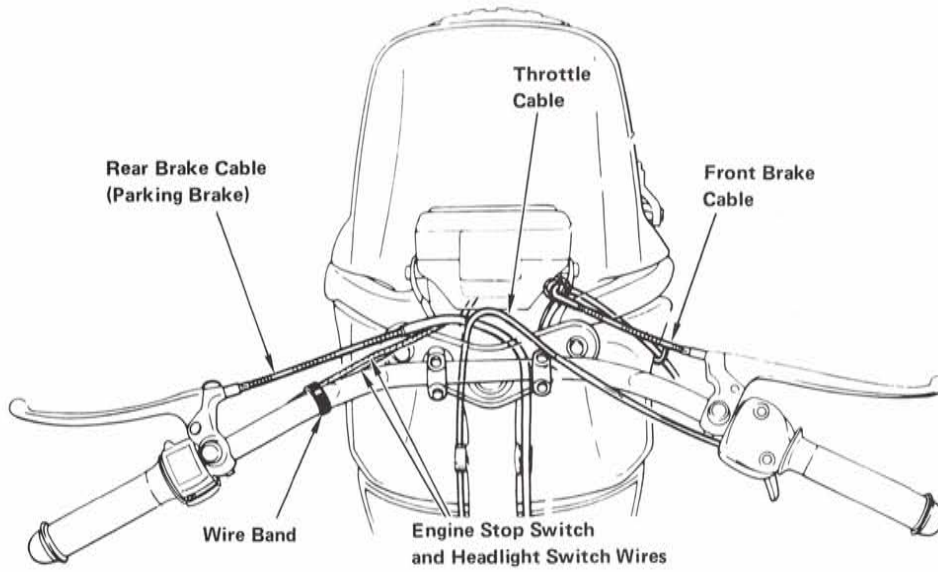

STEP 38— (Continued)



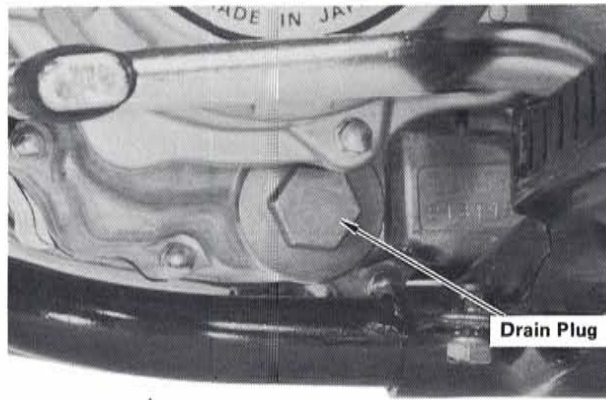

**STEP 39**—Remove crankcase drain plug and drain engine oil. Reinstall and tighten drain plug to specified torque.

*NOTE: Not required if less than 4 months have elapsed since date of manufacture shown on identification plate on steering head.*

Refill crankcase with recommended oil as described in owner's manual.

**Torque specification:**  
1.2 kg-m (9 lb-ft)

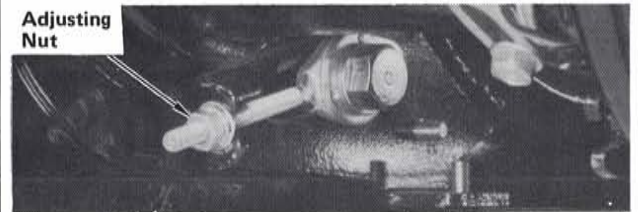
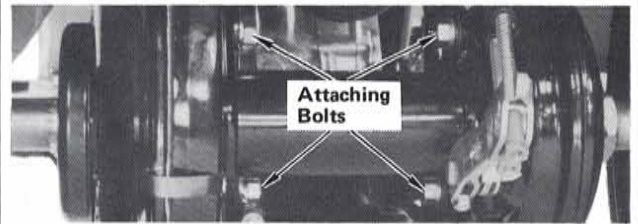
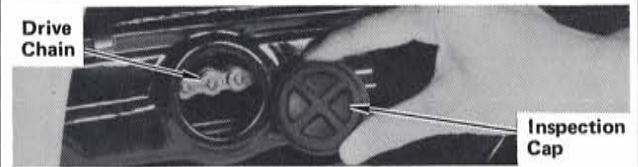

**STEP 40**—Check drive chain slack and lubrication. If necessary, adjust and lubricate drive chain as described in owner's manual or shop manual.

**Slack:** 15–25 mm (5/8–1 in.)

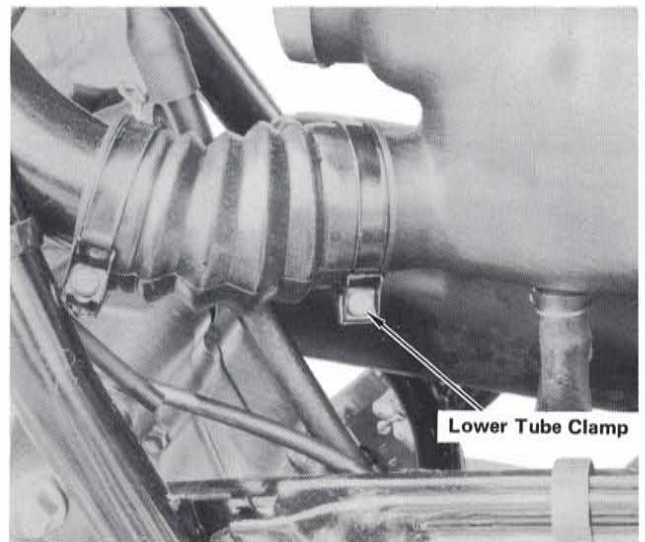
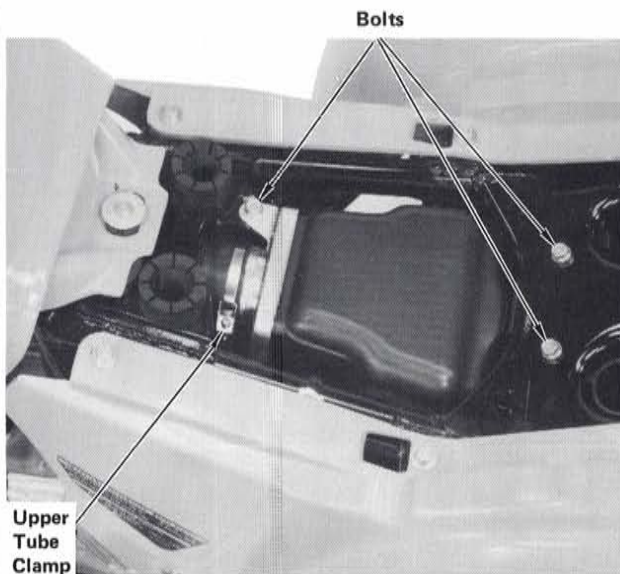

**STEP 41**—Remove three bolts attaching air cleaner case and remove air cleaner upper and lower tube clamps. Remove air cleaner assembly from frame and filter element from its core. Check condition of element. If necessary, clean element as described in owner's manual or shop manual. Reinstall element, air cleaner upper and lower tube clamps, and air cleaner case.



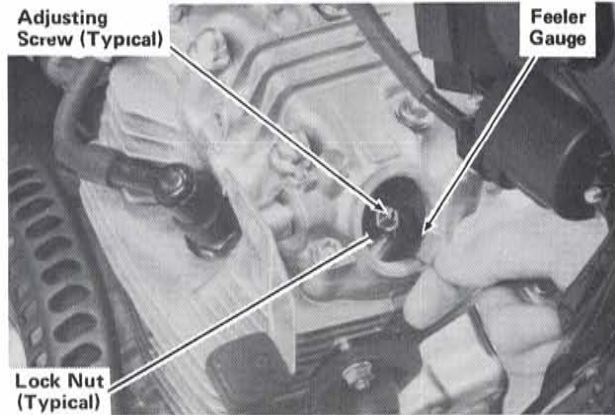
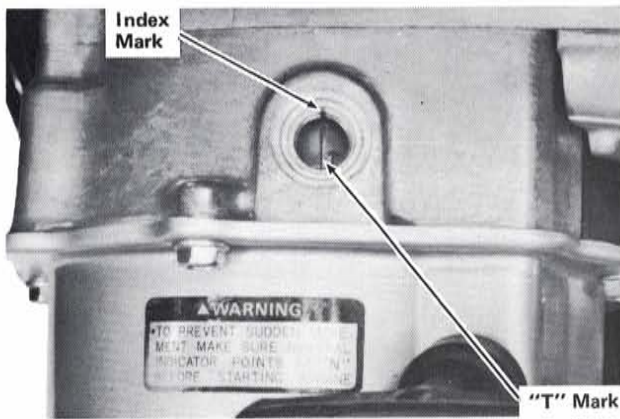

**STEP 42**—Check valve clearance and adjust if necessary as follows:

*NOTE: Valve clearance adjustment must be done while engine is cold (below 35° C; 95° F).*

1. Remove timing mark cap and valve adjuster hole caps.
2. Rotate crankshaft using recoil starter and align "T" mark on rotor with index mark on crankcase. Piston must be at T.D.C. (Top Dead Center) of compression stroke.
3. Insert feeler gauge between adjusting screw and valve stem of intake and exhaust valves.
4. If adjustment is necessary, loosen lock nut and turn adjusting screw as required.
5. After adjustment, hold adjusting screw and tighten lock nut.
6. Recheck valve clearance.
7. Reinstall valve adjuster hole caps.

Intake and Exhaust: 0.05 mm (0.002 in.)

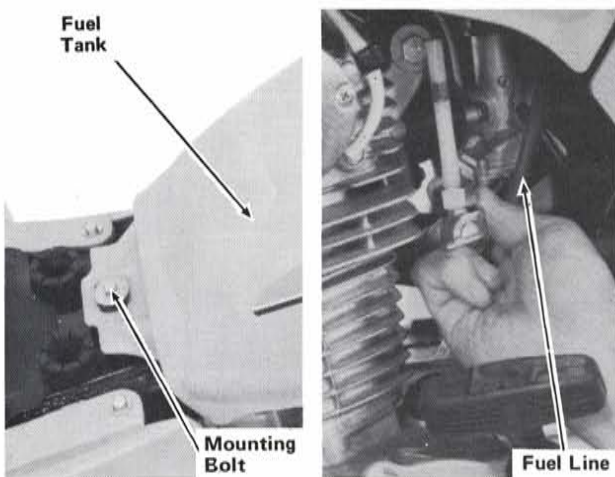

**STEP 43**—Drain fuel tank as described in shop manual. Remove fuel tank by removing mounting bolt at rear of tank and disconnecting fuel line. Inspect and flush fuel tank. Reinstall fuel tank, connect fuel line, fill tank, turn on fuel tank and check for leaks and flow through fuel filter. Tighten mounting bolt securely.

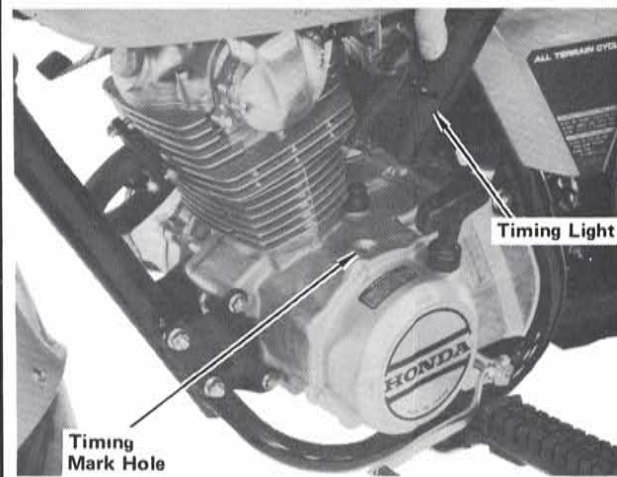

**STEP 44**—Connect a stroboscopic timing light and check transmission in neutral. Start engine and allow it to idle. Aim timing light at timing mark hole and check that "F" mark is aligned with index mark at idle. Reinstall timing hole cap. Remove timing light.

*NOTE: The C.D.I. (Capacitor Discharge ignition) system is factory preset and cannot be adjusted. If timing is incorrect, check C.D.I. units as described in shop manual.*



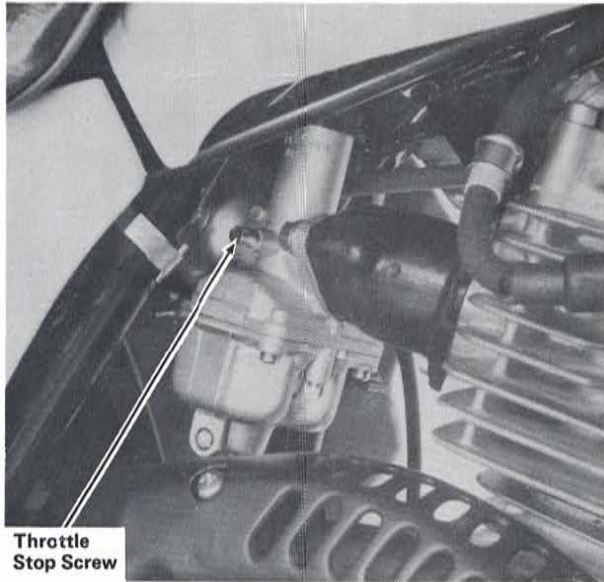

**STEP 45**—Connect a tachometer and check transmission in neutral. Start engine and allow it to warm up to operating temperature and check idle speed at  $1,400 \pm 100$  rpm. If necessary, adjust idle speed using throttle stop screw. Remove tachometer.

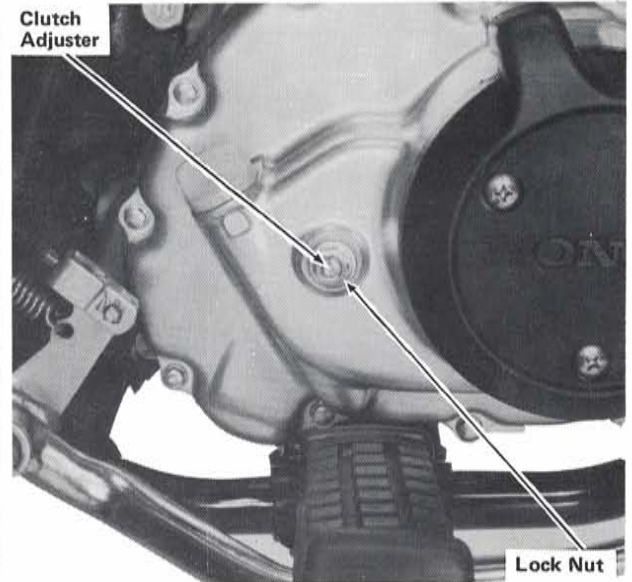

**STEP 46**—Check clutch operation. If adjustment is necessary, use the following procedure. Loosen lock nut and turn clutch adjuster counter-clockwise until resistance is felt, then turn clutch adjuster 1/4 turn clockwise and tighten lock nut. Recheck clutch operation.

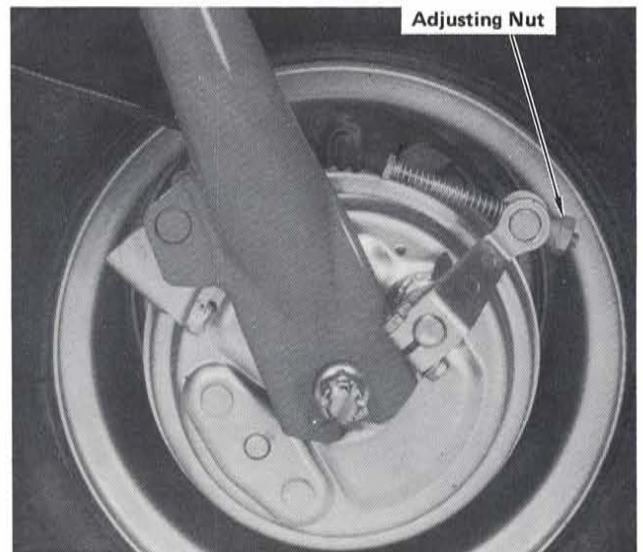
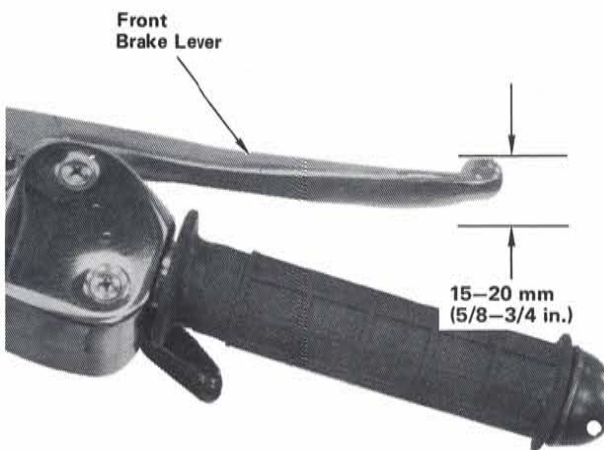

**STEP 47**—Raise front wheel off ground using a support block under engine. Spin front wheel by hand and measure free play of front brake lever before brake starts to engage. Free play, measured at tip of brake lever, should be between 15 and 20 mm (5/8–3/4 in.). If adjustment is necessary, turn adjusting nut on front brake arm. Remove support block under engine.

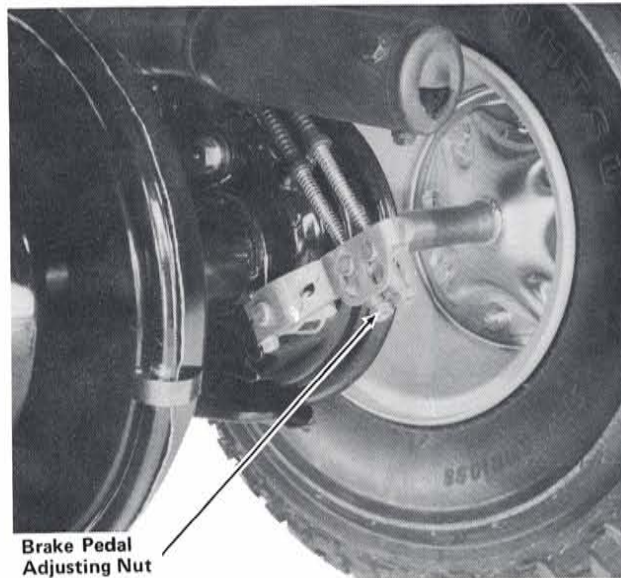
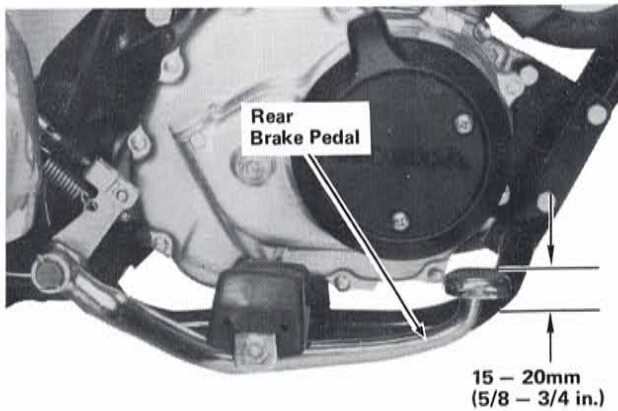

**STEP 48**—Raise rear wheels off ground using a support block under vehicle. Rotate rear wheels by hand measure free play before brake starts to engage. Free play, measured at tip of brake pedal, should be maintained between 15 and 20 mm (5/8–3/4 in.). To adjust free play, turn adjusting nut. Turning adjusting nut clockwise will decrease free play.

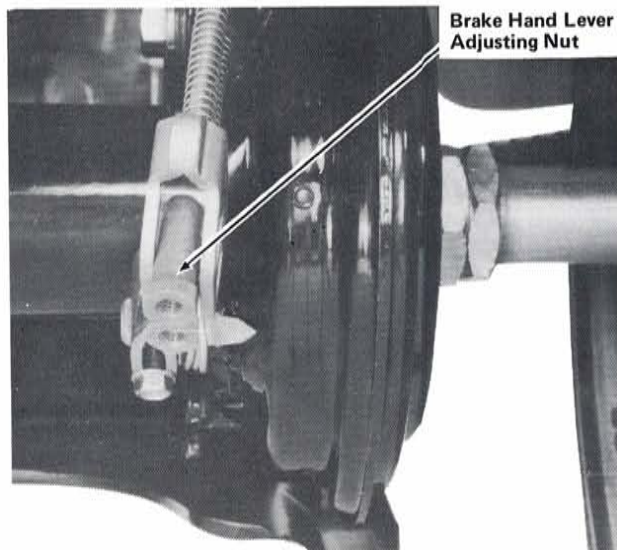
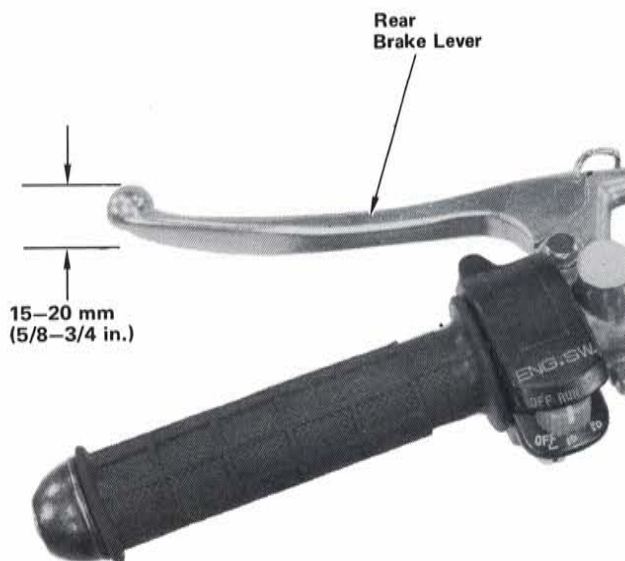

**STEP 49**—Spin rear wheels by hand and measure free play of rear brake lever before brake starts to engage. Free play, measured at tip of brake lever, should be between 15 and 20 mm (5/8–3/4 in.). If adjustment is necessary, turn adjusting nut. Turning adjusting nut clockwise will decrease free play. Remove block from under vehicle.



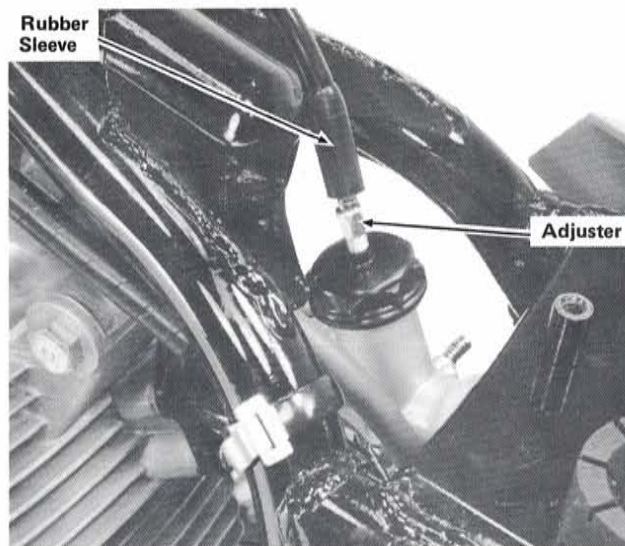
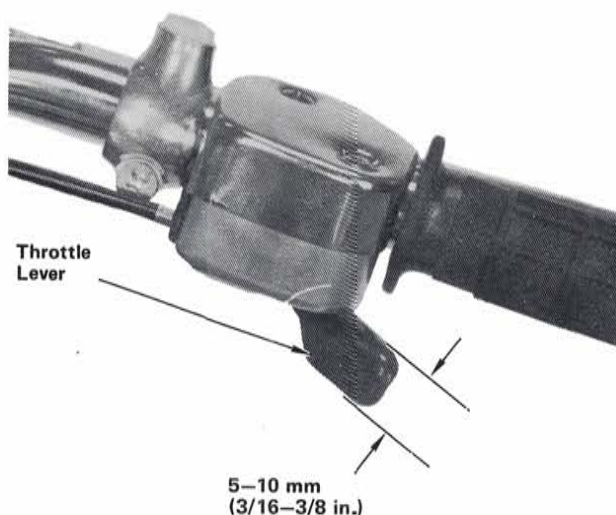

**STEP 50**—Check throttle cable for condition. Check that throttle lever free play is within 5–10 mm (3/16–3/8 in.) at tip of throttle lever. Check for smooth operation of throttle lever from fully closed to fully open in all steering positions and that throttle lever automatically returns from fully open to fully closed when released. If necessary to adjust free play, slide rubber sleeve back to expose adjuster on top of carburetor. Turn adjuster as required and slide rubber sleeve back over cable adjuster.

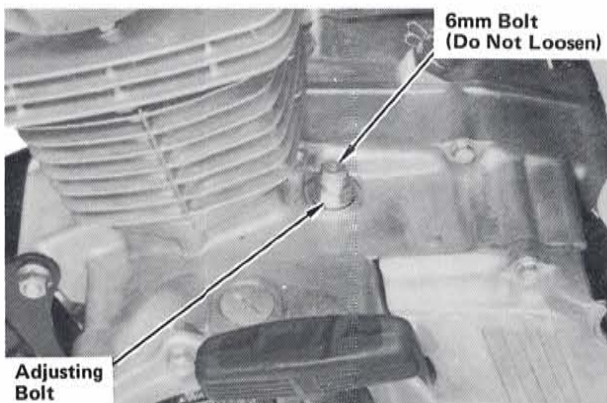

**STEP 51**—Adjust cam chain as follows:

1. Start engine and allow it to idle.
2. Remove rubber cap from tensioner adjusting bolt.
3. Loosen cam chain tensioner adjusting bolt to allow cam chain to automatically adjust itself to correct tension.

*NOTE: Do not loosen the 6 mm bolt.*

4. Retighten cam chain tensioner adjusting bolt.
5. Reinstall rubber cap over tensioner adjusting bolt.

#### 1981 MODEL ONLY

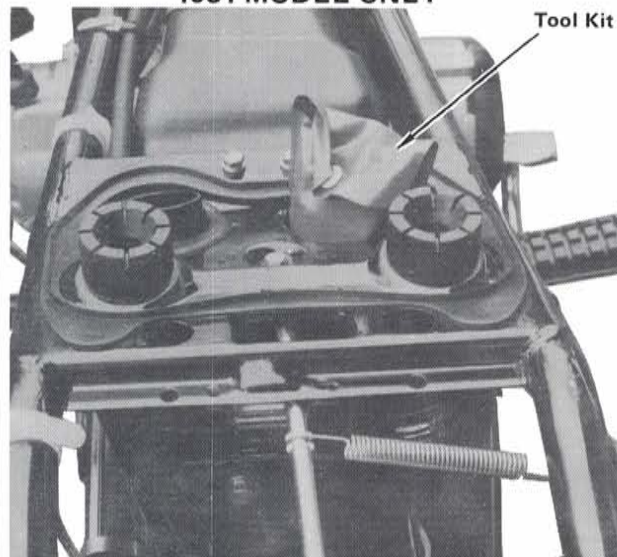

**STEP 52**—Check that tool kit is in its compartment as shown.

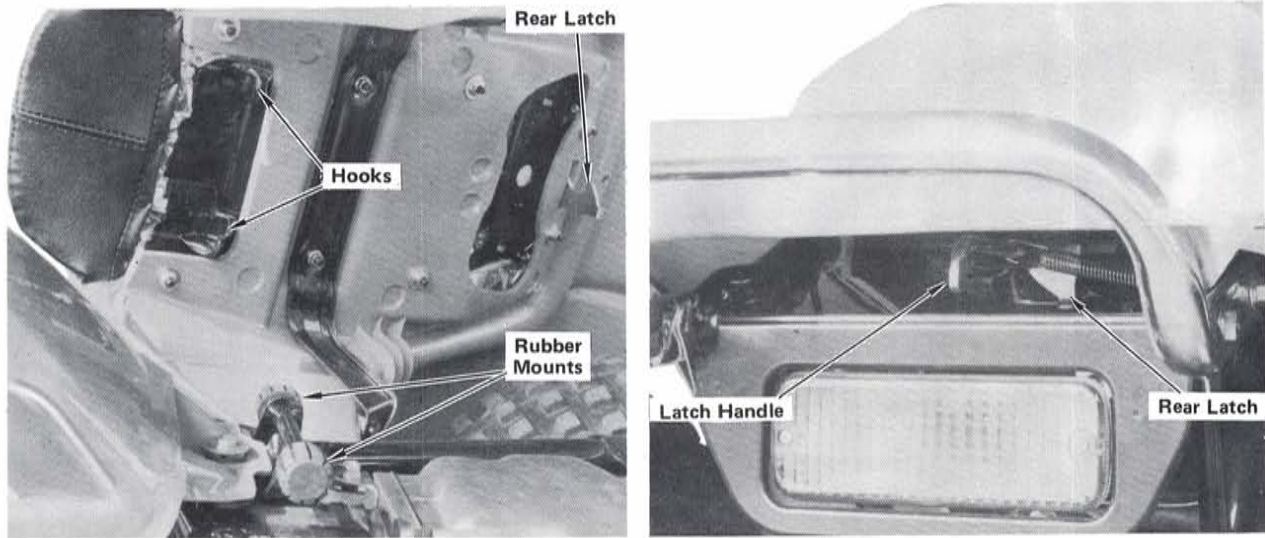

**STEP 53**—Slip hooks at front of seat over rubber mounts on frame and lock rear of seat down with latch. Be sure latch is fully engaged.

**1982 MODEL ONLY**

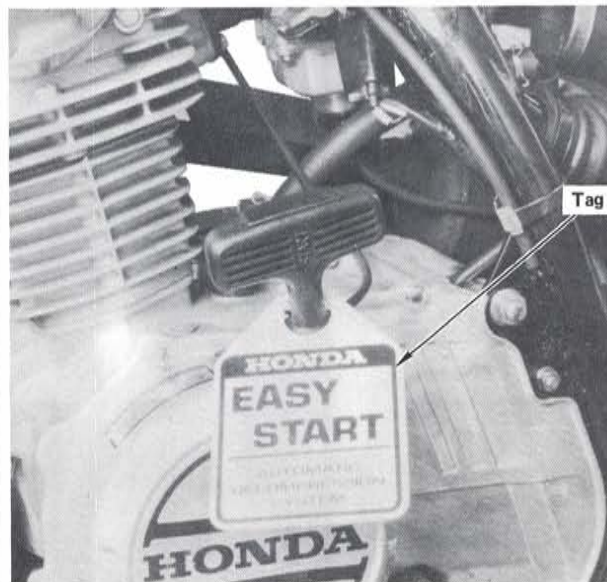

**STEP 54**—Attach “Easy Start” tag to recoil starter handle as shown.



1981 MODEL ONLY

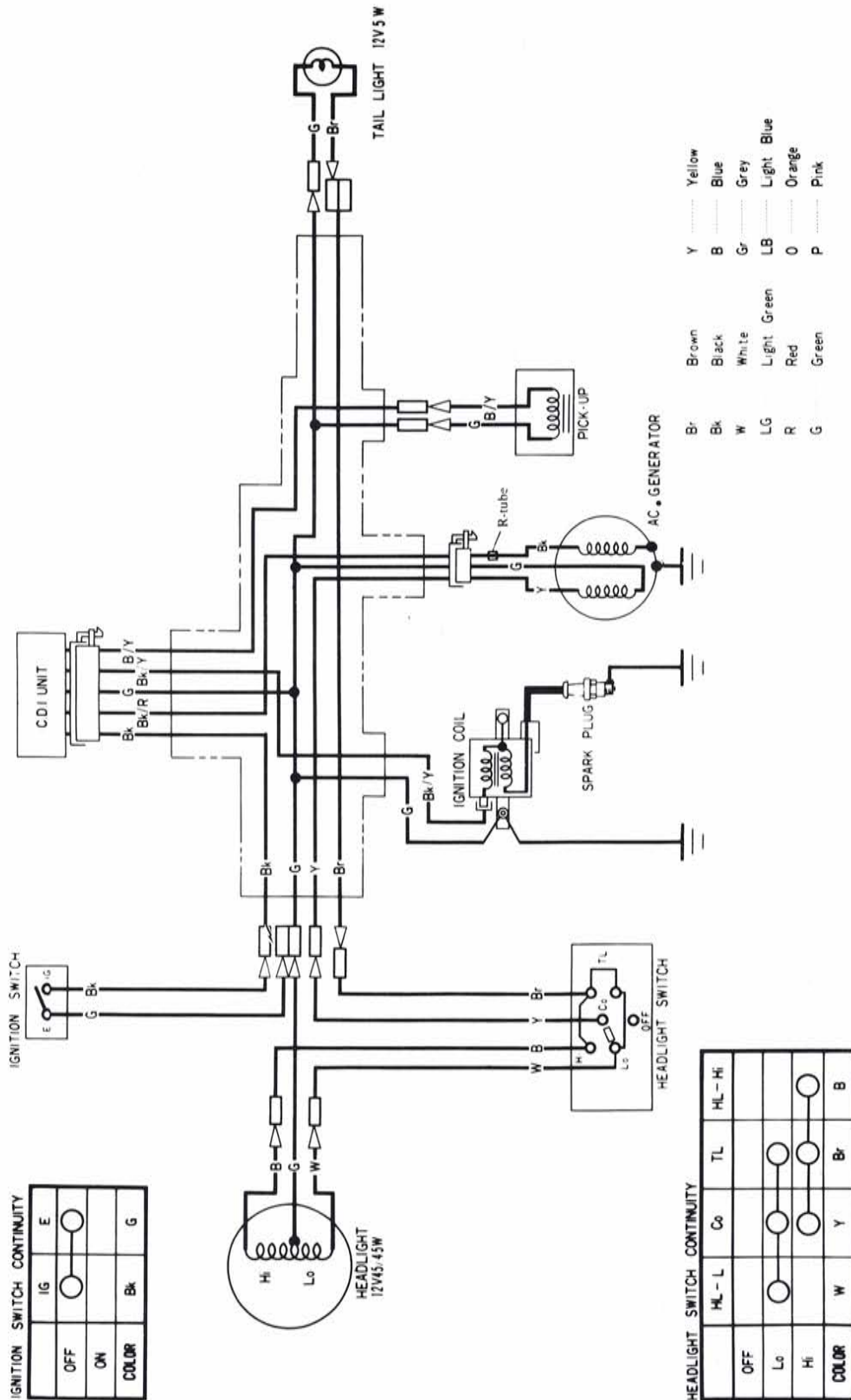

1982 MODEL ONLY

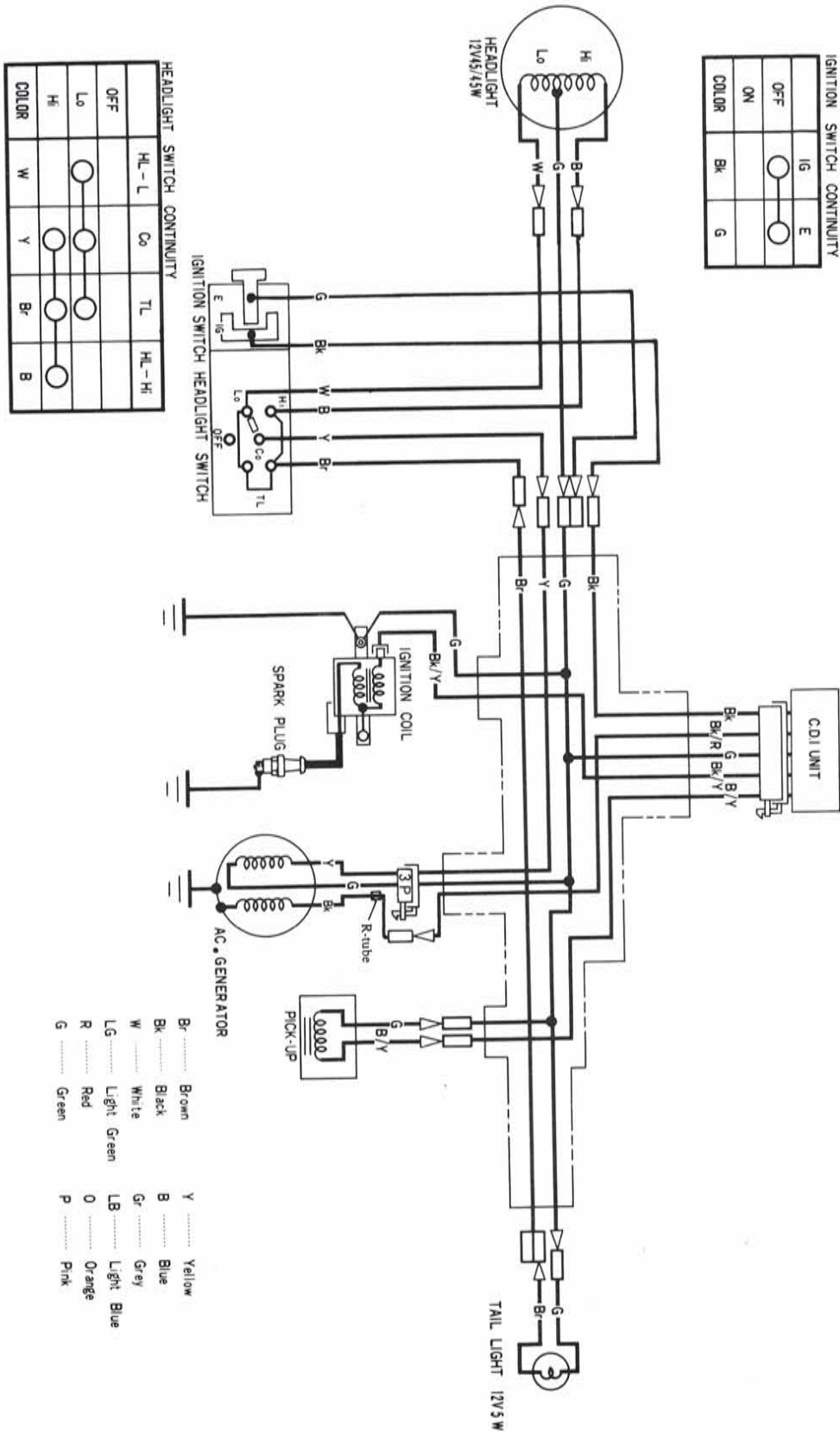



**TORQUE TABLE**

ITEM	SIZE	TORQUE
Front fork bolts	12 mm	6.0 kg-m (44 lb-ft)
Handlebar upper holder bolts	6 mm	1.0 kg-m (8 lb-ft)
Front fender bolts	6 mm	1.0 kg-m (8 lb-ft)
Front axle nuts	12 mm	6.0 kg-m (44 lb-ft)
Rear wheel hub nuts	8 mm	2.2 kg-m (16 lb-ft)
Rear axle nuts	14 mm	7.0 kg-m (51 lb-ft)
Carrying handle	8 mm	2.2 kg-m (16 lb-ft)
Oil drain plug	36 mm	1.2 kg-m (9 lb-ft)
Valve adjuster caps	36 mm	1.2 kg-m (9 lb-ft)
Cam chain tensioner bolt	16 mm	1.8 kg-m (13 lb-ft)

*NOTE: Check all items listed on the following Pre-delivery Service Check List. Refer to owner's manual or shop manual for specifications and detailed procedures. Always test ride the unit to make sure that it is functioning properly.*

**PRE-DELIVERY SERVICE CHECK LIST**

- Adjust front and rear brakes, check cable routing and check operation.
- Drain oil from crankcase (if necessary). Refill crankcase with recommended oil.
- Remove and inspect fuel tank, drain and flush.
- Check and clean air filter element.
- Check valve clearance; adjust if necessary.
- Check operation of decompression system.
- Reinstall fuel tank, fill, turn on petcock and check for leaks.
- Check ignition timing.
- Adjust idle speed.
- Check throttle lever free play, cable routing, and operation in all steering positions.
- Adjust cam chain tension.
- Adjust and lubricate drive chain.
- Check tire pressure.
- Inspect electrical components for proper operation and adjustment.
  - Headlight switch.
  - Headlight: Adjust high and low beam aim.
  - Taillight.
  - Engine stop switch.
- Check security of all nuts, bolts, and other fasteners.
- Check to ensure all applicable recall and product update campaigns are complied with.
- TEST RIDE:** Check performance, handling, and operation:
  - Transmission and clutch: Ease of shifting, clutch operation, etc.
  - Acceleration: Smoothness, etc.
  - Cruising: Smoothness, etc.
  - Handling: Stability and cornering.
  - Brakes: Smoothness and stopping power.
  - Idling: Smoothness, throttle response, and return to idle.
  - Recheck idle speed after 10 minutes of stop and go operation.
  - Upon completion of test ride, check for fuel and oil leaks.

## LOOSE PARTS

The following is a list of items contained in the parts package carton and loose parts in the crate:

PART NAME	QTY	H/C	PART NUMBER
Upper holder	2	066162	95014-21101
Washer, plain, 6 mm	4	005907	94101-06000
Bolt, hex 6 x 28 mm	4	017012	90117-065-000
Washer, 14 mm (1981)	2	070792	42322-943-000
Washer, 14 mm (1982)	2	-----	42322-950-000
Nut, castle, 14 mm	2	023402	94011-1400-0S
Pin, cotter, 3 x 25 mm	2	005842	94201-30250
Rear mud flap	2	100089	80111-958-670
Rear backing plate (rear)	2	100380	80112-958-670
Rear backing plate (side)	2	100381	80113-958-670
Bolt, screw, 4 x 12 mm	10	032208	90164-357-000
Washer, plain, 4 mm	10	033146	94101-04800
Nut, hex, 4 mm	10	056211	94001-04080-0S
Carrier pipe, comp.	1	100383	81200-958-670
Bolt/washer, 8 x 20 mm	4	073767	93493-08020-08
Washer, front cover fixing	4	029937	64348-086-000
Bolt, hex, 6 x 12 mm	4	073745	92000-06012-0H
Washer, plain, 6 mm	2	045012	94103-06000
Front mud flap	1	096603	61111-943-000
Nut, headlight setting	3	095557	61304-958-003
Screw, 6 x 7 mm	3	081065	90102-673-003
Front axle	1	100270	44301-958-670
Front axle collar	2	023386	44302-918-000
Nut, axle, 12 mm	2	095562	90305-169-000
Pin, cotter, 3 x 25 mm	2	005842	94201-30250
Front axle side collar	1	084233	44312-958-000
O-ring, 13.5 x 1.4 mm	2	034790	91307-611-000
Rear wheel hub (1981)	2	070793	42410-943-000
Rear wheel hub (1982)	1	-----	42410-958-670
Washer, spring, 8 mm	6	005898	94111-08000
Nut, hex, 8 mm	6	016733	94001-0800-0S
Brake arm joint B	1	040094	95015-32001
Adjust nut B	1	025776	95015-42000
Brake rod spring A	1	027105	95014-73100
Front brake stopper collar (1981)	1	084226	45101-958-000
Front brake stopper bolt (1981)	1	095534	90124-958-000
Nut, self lock, 8 mm (1981)	1	059948	90115-659-003
Pin, cotter, 2.0 mm (1981)	1	005834	94201-20150
Owner's manual (1981)	1	094863	3195801
Owner's manual (1982)	1	106996	3195802
Easy start tag (1982)	1	-----	87107-958-000





READ THIS READ THIS READ THIS

READ THIS READ THIS READ THIS

# HONDA

MODIFICATIONS WHICH YOU HAVE MADE, OR SHOULD MAKE IN THE FUTURE, TO ANY HONDA MOTORCYCLE, SHALL BE DEEMED BY OUR COMPANY TO HAVE BEEN PERFORMED AT YOUR SOLE RISK AND RESPONSIBILITY, AND WITHOUT OUR COMPANY'S OR THE MANUFACTURER'S APPROVAL OR CONSENT, IMPLIED OR EXPRESSED. WE FURTHER DISCLAIM ANY AND ALL LIABILITY, OBLIGATION, OR RESPONSIBILITY FOR ANY DEFECTS OF MODIFIED PARTS OR OF THE MODIFIED MOTORCYCLE, AND FOR ANY CLAIMS, DEMANDS, OR CAUSES OF ACTION FOR DAMAGE TO PROPERTY OR FOR PERSONAL INJURIES RESULTING FROM THE MODIFICATION OF SAID HONDA MOTORCYCLE.

READ THIS READ THIS READ THIS